

# READ AND SAVE THESE INSTRUCTIONS

Operator's Manual



## WHOLE HOUSE HUMIDIFIER

12 Gallon Output with  
Digital Readout  
Model 758.154120

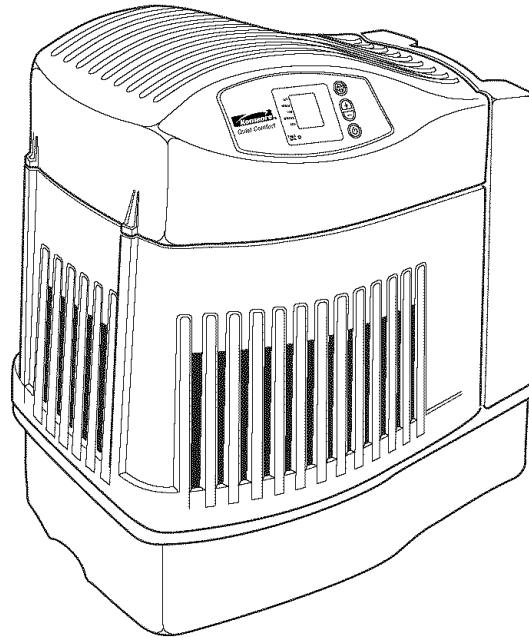

**CAUTION:** Before using this product, read this manual and follow all its Safety Rules and Operating Instructions.

- Safety
- Assembly
- Operation
- Maintenance
- Parts
- Español, p. 17

Sears, Roebuck and Co., Hoffman Estates, IL 60179 U.S.A.  
[www.sears.com](http://www.sears.com)

Part No. SP6592

Printed in Canada

## ONE YEAR FULL WARRANTY ON KENMORE HUMIDIFIER

If any part of this humidifier fails due to a defect in material or workmanship within one year from the date of purchase, or if the humidifier motor fails due to a defect in material or workmanship during the second year from the date of purchase, RETURN THE HUMIDIFIER TO THE NEAREST SEARS PARTS & REPAIR CENTER, and it will be repaired free of charge. This warranty does not include humidifier filters, which are expendable parts that can wear out from normal use in less than one year. This warranty gives you specific legal rights, and you may also have other rights which vary from state to state.

Sears, Roebuck and Co., Dept. 817WA, Hoffman Estates, IL 60179

## GENERAL SAFETY INSTRUCTIONS

### Safety Signal Words

**DANGER:** means if the safety information is not followed someone **will** be seriously injured or killed.

**WARNING:** means if the safety information is not followed someone **could** be seriously injured or killed.

**CAUTION:** means if the safety information is not followed someone **may** be injured.

1. To reduce the risk of fire or shock hazard, plug humidifier directly into a 120V, A.C. electrical outlet. Do not use extension cords.
2. Keep the electric cord out of traffic areas. To reduce the risk of fire hazard, never put the electric cord under rugs, near heat registers, radiators, stoves or heaters.
3. Always unplug the humidifier before moving it, before cleaning, or whenever the humidifier is not in service.

4. Keep the humidifier clean.
5. Do not put foreign objects inside the humidifier.
6. Do not allow to be used as a toy. Close attention is necessary when used by or near children.
7. Never use your humidifier while any part is missing or damaged in any manner.
8. To reduce the risk of electrical hazard or damage to humidifier, do not tilt, jolt or tip humidifier while unit is running.
9. To reduce the risk of damage to humidifier, unplug when not in use.
10. To reduce the risk of accidental electrical shock, do not touch the cord or controls with wet hands.
11. Note the warning label shown below.

**WARNING:** To reduce risk of fire, electric shock, or injury always unplug before servicing or cleaning.

## Table of Contents

Warranty Information.....	2	Electrical Hook-Up .....	5
General Safety Instructions .....	2	Step 3. Water Fill .....	6
To Save A Service Call .....	3	Step 4. Operating the Controls .....	7-8
Know Your Humidifier .....	3	Using Your Humidifier .....	9-10
How Your Humidifier Works .....	4	Replacement and Care of Filters .....	11
Step 1. Getting Your Humidifier Up and Running .....	4	Cleaning and Maintenance .....	12
Step 2. Location Instructions .....	5	Troubleshooting .....	13
		Repair Parts .....	14-15

## To Save A Service Call

Check the following if your humidifier is not operating.

1. Is power cord attached to outlet?
2. Is there electrical power to outlet?
3. Is fan control on?
4. Is humidity control set high enough?
5. Is the cabinet sitting on a level surface?

## Know Your Humidifier

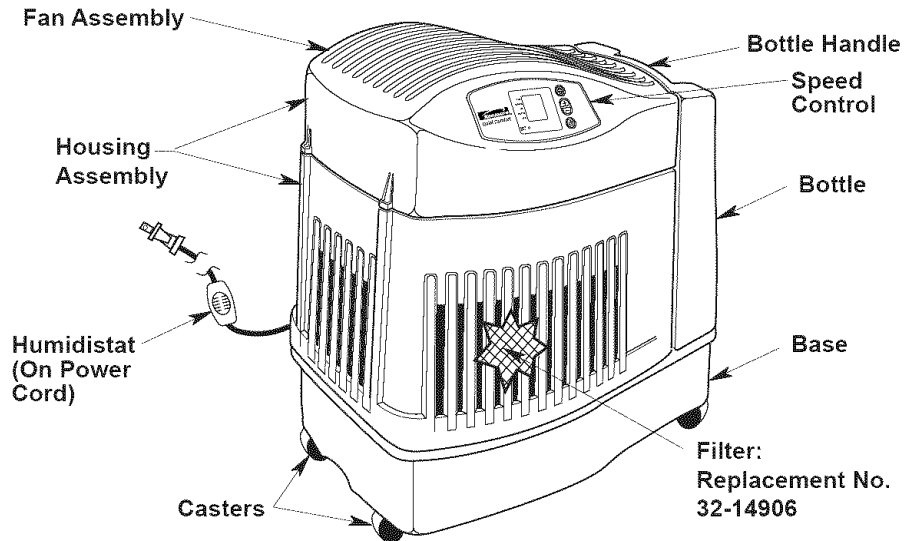

Description	758.154120
* Gallon Output/24 hrs.	12
Capacity of Bottle	1.9 Gallons
Capacity of Base	2.0 Gallons
* Sq. Ft. Coverage	2500
Fan Speeds	4
Auto Fan Speed	Yes
Replacement Filter	32-14906
Power Light	Yes
Fill Light	Yes
Auto Humidistat	Yes
Auto Shut Off	Yes
Controls	Electronic (Push Button)
Casters	Yes (4)
CUL Listed	Yes
Volts	120 A.C.
Hertz	60
Amps (High Speed)	0.80
Watts (High Speed)	80

\* Based on an area with average insulation and an 8 foot ceiling height

## How Your Humidifier Works

Your new Kenmore humidifier is designed to satisfy home humidity requirements through the principle of evaporation of water in the air. Once the filter becomes saturated, air is drawn in, passes through the filter and moisture is absorbed into the air. All evaporation occurs in the humidifier so any residue remains in the filter. This natural process of evaporation virtually eliminates white dust.

**CAUTION:** To reduce the risk of injury, fire or damage to humidifier, use only cleaners specifically recommended for humidifiers. Never use flammable, combustible or poisonous materials to clean your humidifier. To reduce the risk of scalds and damage to humidifier, never put hot water in humidifier.

Humidified air is then released through the top

Dry air enters through the louvers in the housing

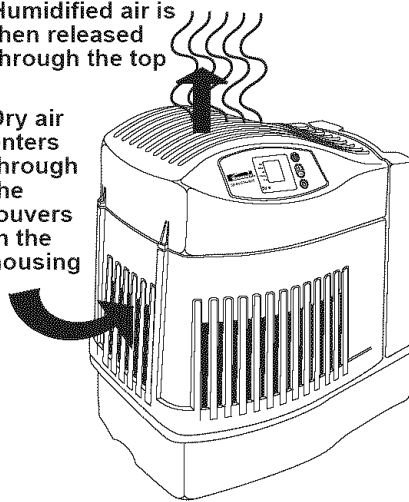

## Step 1. Getting Your Humidifier Up and Running —

### Assembly

Remove casters, water bottle, housing assembly, and filter from the box and reverse the base. Press casters into the bottom of the base manually. **Do not use tools.** Set the base upright.

Replace the filter, housing assembly and bottle (See "Replacement and Care of Filters", page 11 for reference).

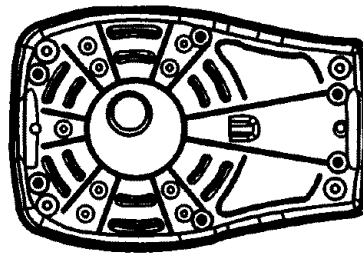

## Step 2. Location and Electrical Hook-Up

**WARNING:** For your own safety, do not use humidifier if any parts are damaged or missing.

### Selecting A Location

Place humidifier on a flat level surface, take extra care in leveling when placing the unit on carpet. Position the humidifier where the most humidity is needed or where the most air will be circulated throughout the house such as near a cold air return.

Moist air (humidity) produced will disperse into the whole house, but the area closest to the unit will have the highest humidity. If the unit is positioned close to a window, condensation may form on the window pane. If this occurs the unit should be repositioned in another location.

**NOTE:** Due to release of cool, moist air from humidifier, it is best to direct air away from thermostat and hot air registers and to position humidifier next to an inside wall. Unit should not be placed where cold air from outside walls or warm air from a hot air register blows directly on it.

### Positioning The Unit

The humidifier should be positioned with the back (cord exit side) and left side, at least 2 inches away from the wall. Air needs to enter through all of the louvers in the housing assembly in order for the humidifier to operate at peak efficiency.

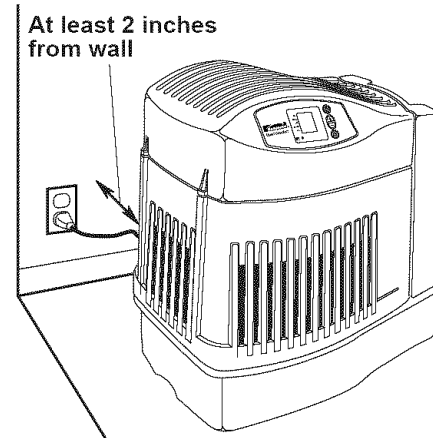

**NOTE:** Be sure humidistat, which is located on power cord, is free from obstruction and away from any hot air source.

## Electrical Hook-Up

Locate nearest 120V A.C. wall socket in the location desired, preferably on inside wall. With the humidifier in the desired location, route the electrical cord safely so no one will trip or upset the humidifier. Plug in the electrical cord.

**WARNING:** To reduce the risk of fire or shock hazard, humidifier should be plugged into a 120V A.C. outlet. Do not use extension cords.

To reduce the risk of electrical shock, this humidifier has a polarized plug (one blade is wider than the other). This plug will fit in a polarized outlet only one way.

If the plug does not fit fully in the outlet, reverse plug. If it still does not fit, contact a qualified electrician to install the proper outlet. Do not change the plug in any way.

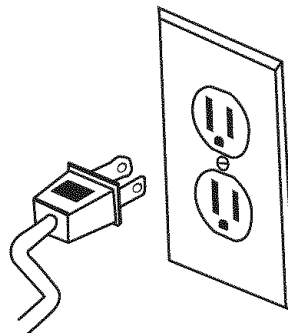

### Step 3. Water Fill

**WARNING:** To reduce the risk of fire or shock hazard, do not pour or spill water into control or motor area. If controls get wet, let them dry completely and have unit checked by authorized service personnel before plugging in.

After the humidifier is positioned where it will be operating you are ready to fill the humidifier. The bottle lifts straight up and away from the base. Take care not to bump or damage fill valve assembly on the bottom of the bottle.

Remove the "E-Z Fill Side Cap" and fill with water. Replace cap and twist by hand until secure. Hold the bottle upright over the sink. Press up on the valve plunger for one second to release a small amount of water. If you hear air bubbles or see leaks around the "E-Z Fill Side Cap" or Spring Valve Assembly, retighten and recheck.

**CAUTION:** Use only 32-14900 EPA Registered Bacteriostat available from Sears Retail store. Under no circumstances should you use water treatment products designed for Roto belt or Ultrasonic humidifiers.

Place the water bottle back into the humidifier base. When positioned properly, the plunger will open and the water will flow into the base. The base will hold the entire contents of the water bottle. Once the bottle is empty, remove it and repeat the filling process. The humidifier is now filled to capacity. To benefit from less frequent filling let the humidifier exhaust both the water from the bottle and the base before filling.

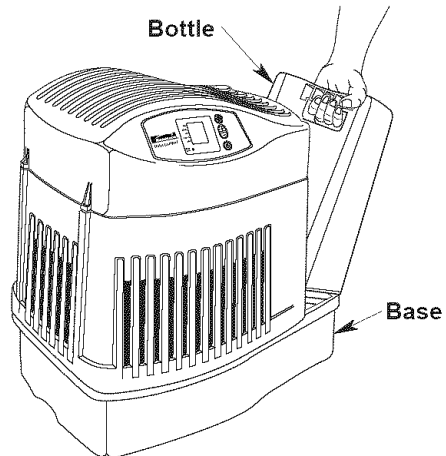

Turn Counterclockwise to Remove "E-Z Fill Side Cap"

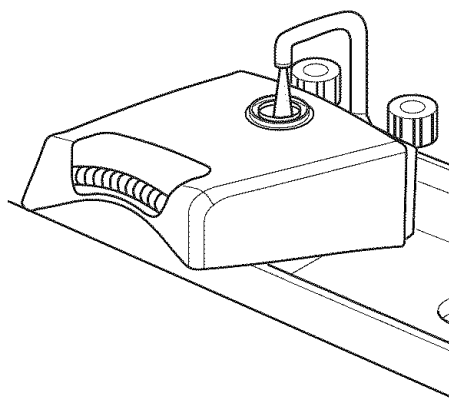
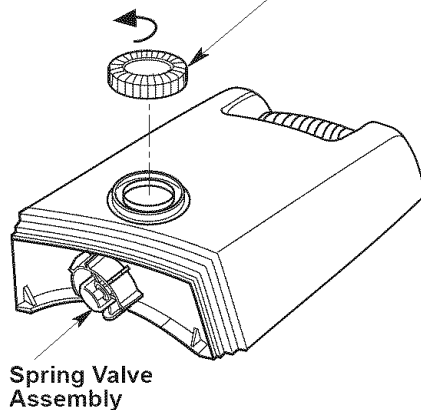

## Step 4. Operating the Controls

Where you set your desired humidity levels depends on your personal comfort level, outside temperature and inside temperature. A starting set point of 30% - 40% **ROOM** humidity is recommended but there may be conditions that require a different setting.

**IMPORTANT:** Water damage may result if condensation starts to form on windows or walls. Humidity **SET** point should be lowered until condensation no longer forms. We recommend room humidity levels do not exceed 50%.

When Outdoor Temperature is:		Recommended Indoor Relative Humidity (RH) is:
-10° F	-24° C	20%
2° F	-18° C	25%
10° F	-12° C	30%
20° F*	-6° C*	35%

\* and above

### To Operate the Controls

#### Digital Display

Press the power button  once to display the digital readout\*. Initially there is a slight delay while the electronics calibrate.

Two bars (- -) flash during this time. Once calibration is complete a **ROOM** humidity reading between 25% - 95% will be displayed. A flashing 20 display indicates that the room humidity is less than 20%.

**NOTE:** The default settings at initial startup are **WHISPER** fan speed and **65% SET** humidity. After desired settings are selected by the user, they remain as long as the unit remains plugged in and there is no power interruption. If the unit is unplugged the **original** default settings are employed.

\* Humidifier fan should operate at initial start up. If it does not, refer to, "Fan not operating (digital display is illuminated)" in the "Trouble Shooting" section on page 13 of this manual.

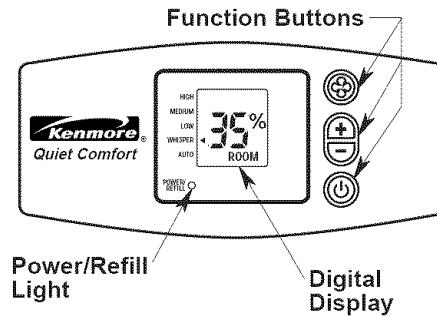

## Operating the Controls (cont'd.)

### Speed Button

This humidifier is equipped with a 4-speed fan control. Each push of the speed button advances the mode through the settings of **HIGH**, **MEDIUM**, **LOW**, **WHISPER**, and **AUTO**. The selected setting is displayed on the digital readout. The higher the setting, the faster water is evaporated and released into the air. **WHISPER** is the quietest setting and is provided for conditions that do not require a rapid evaporation rate.

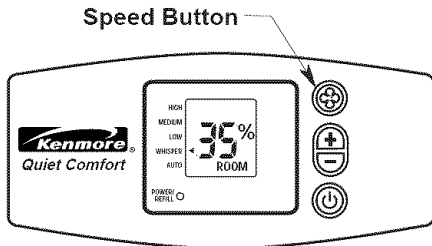

### How Auto Control Works

The **AUTO** setting allows the humidifier to manage its speed range to maintain your desired humidity setting. It will automatically cycle to the most efficient speed to achieve the desired humidity. Here is how the fan will operate:

- **HIGH** speed if room humidity is 15% or greater RH (Relative Humidity) below the **SET** point.
- **MEDIUM** speed if room humidity is 15 - 10% RH below the **SET** point.
- **LOW** speed if room humidity is 10 - 5% RH below the **SET** point.
- **WHISPER** speed if room humidity is 5% RH or less.

If the room humidity is not increasing at the current fan speed during a 15 minute period, the fan speed increases to the next higher speed until the humidity **SET** point is reached.

**NOTE:** The humidifier may run on **HIGH** for an extended period of time if the actual room humidity is extremely low.

### Humidity Control

These buttons allow you to adjust the humidity to suit your needs. This humidifier will automatically cycle on and off as required to maintain the selected setting. Press the humidity buttons  to cycle the **SET** humidity readout in 5% increments between 25% and 65% RH. Once you have set the desired humidity, after 5 seconds the readout will change to the actual room humidity.

**NOTE:** When the **ROOM** humidity is displayed, pressing the set humidity buttons once will display the current **SET** point. To increase or decrease the current **SET** point, press either the "+" or "-" button until the desired **SET** point is reached.

A **SET** point of 65% RH operates the humidifier continuously regardless of the **ROOM** reading. The humidistat that senses the readings is located on the power cord. Insure that it is free from obstruction.

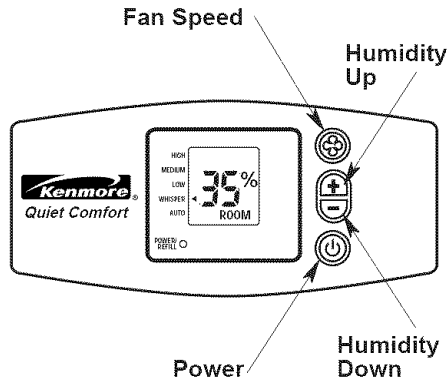



# Using Your Humidifier

## Power/Refill Light

For maximum run time both the bottle and the base should be filled. When both the bottle and the base are empty the red **POWER/REFILL** light will flash, informing additional water is required. Also at this time the unit will automatically switch into **DRY OUT** and continue to run on **WHISPER** speed for a 2 hour period. The message **DRY OUT** will appear on the digital display and the fan speed will switch to **WHISPER** speed.

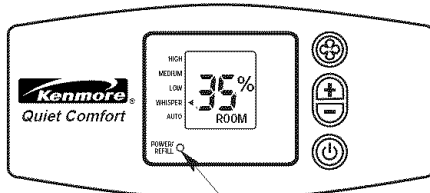

Power/Refill Light

**NOTE:** During this time the room humidity level will continue to be monitored and the humidifier will cycle the fan on and off until the filter is completely dry. The fan will shut off leaving you with a dry humidifier that is less prone to mold and mildew growth. If **DRY OUT** is not desired, refill the humidifier with water.

**NOTE:** Once the dry out cycle is complete, the fan will shut off and the **POWER/REFILL** light will stay illuminated. The humidifier will automatically start again when it is refilled.

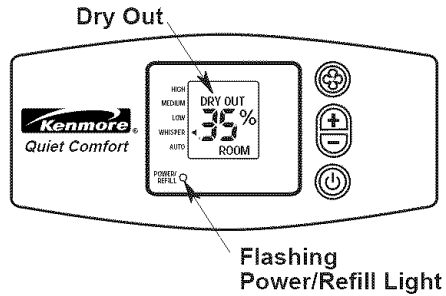

## Check Filter Indicator

The ability of any humidifier to efficiently supply humidity output relies heavily on the condition of the filter. As the filter loads with impurities it gradually loses its wicking capability. When this happens, moisture output is reduced and the humidifier has to work longer to satisfy the selected setting. This humidifier has a check filter reminder timed to appear after 720 hours of operation. When the **CK FILTER** message is displayed, disconnect the power cord and check the condition of the filter. If a build-up of deposits or severe discoloration is evident replace the filter to restore maximum efficiency. The **CK FILTER** message is reset when the humidifier is plugged back in.

## Check Filter

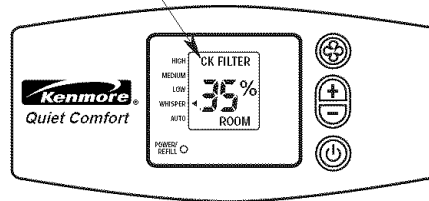

## Using Your Humidifier (cont'd.)

### Humidistat

The humidistat located on the power cord senses the percentage of humidity in the air. It causes the humidifier to cycle on and off to maintain the selected humidity **SET** point. The fan will turn on if the **ROOM** reading falls 3% below the **SET** point and will continue to run the humidifier until a reading of 1% above the **SET** point is achieved. The fan will turn off until the **ROOM** reading falls 3% below the **SET** point again.

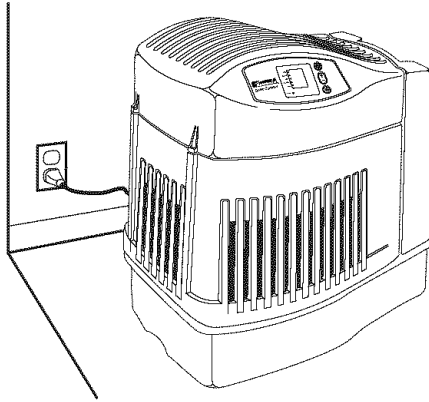

**NOTE:** Be sure humidistat, which is located on power cord, is free from obstruction and away from any hot air source.

### Control Lock Out

This feature allows the controls to be locked to avoid unwanted tampering.

### Activation Procedure

After the desired humidifier settings have been set, press and hold the power button down for 5 seconds. The key icon  will be displayed indicating the control lock is active. If any buttons on the control are pressed while lock out is active, **CL** will be displayed on the LCD screen for 3 seconds and then return to normal and standard LCD display screen and humidifier operation resumes.

### Deactivation Procedure

To deactivate, press and hold the power button for 5 seconds. The key icon  will disappear. Humidifier settings may now be changed as desired.

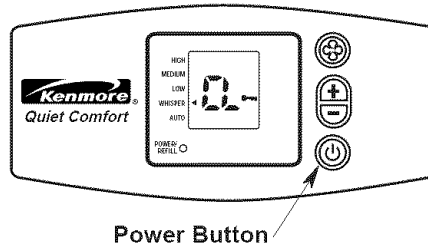

## Replacement and Care of Filter

**WARNING:** To reduce the risk of shock or injury from moving parts, always unplug humidifier before removing or replacing any parts.

**CAUTION:** To help retard bacteria growth and keep maximum efficiency, the filter should be replaced at least once per season, or more often under hard water conditions. Use Kenmore 32-14906 recommended replacement filter.

Replace the evaporative wicking filter at least once per humidification season or more depending on water conditions in your area.

### Filter Replacement

1. Unplug humidifier. Before removing the filter, we recommend moving the humidifier to an area where floor coverings are not susceptible to water damage. (i.e. kitchen or bath areas.)
2. Remove the water bottle and set aside. Be sure not to bump or damage the fill valve.
3. Grasp the housing assembly and lift straight up and away from the base and set aside. The filter is now accessible.
4. Take note of the filter position. Remove the filter. You may want to clean the base at this time. See the "Cleaning Your Humidifier" section of this manual.
5. Install a new filter (32-14906) into the base. Coil the filter and position it between the uprights in the bottom of the base. The start and finish of the coil should be captured at the center of the base (see diagram) and the filter should be resting on the floor of the base.
6. Return the housing assembly to the top of the base. Reposition the humidifier to its operating position.
7. The humidifier is now ready to be filled for operation.

Grasp housing assembly securely and lift off

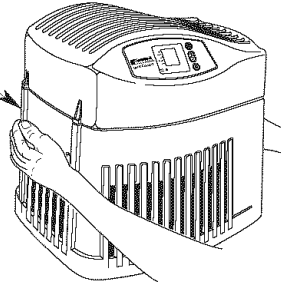

Position start and finish of coiled filter at center of base

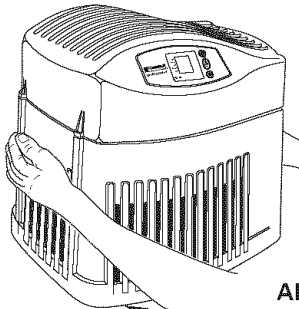
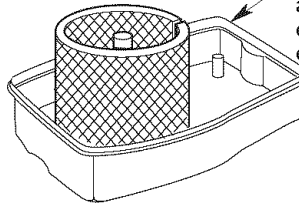

Align housing assembly bottom with top of base and reposition securely

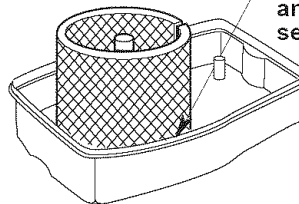

## Cleaning and Maintenance

**WARNING:** To reduce the risk of injury, fire or damage to humidifier, use only cleaners specifically recommended for humidifiers. Never use flammable, combustible or poisonous materials to clean your humidifier. To reduce the risk of scalds and damage to humidifier, never put hot water in humidifier.

**CAUTION:** Local water purity varies from area to area and under certain conditions water impurities and airborne bacteria may promote the growth of microorganisms in the reservoir of the humidifier. To retard bacteria growth that may cause odors and be harmful to your health, use only Kenmore replacement filters. We also recommend using EPA approved bacteriostat, and humidifier cleaner, available at your local Sears store.

### Step 1

To make cleaning easier, the humidifier base should be empty and completely dried out. To accomplish this, use the following method:

- a. Allow the humidifier to run until the **POWER/REFILL** light flashes and the **DRY OUT** mode has stopped the humidifier fan.
- b. Unplug humidifier.

**WARNING:** To reduce the risk of shock, always unplug humidifier before cleaning or servicing. If humidifier is not un-plugged, fan could start after housing is removed.

### Step 2

#### To Remove Parts

See "Replacement and Care of Filter" page 11.

**NOTE:** There may be a little water still in the base. Carefully dump the water out or remove with a sponge.

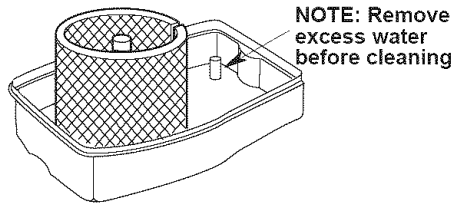

### Step 3

#### Bi-Weekly Maintenance

##### Removing Scale

1. Fill the humidifier base with one 8 oz. cup of undiluted white vinegar. Let solution stay 20 minutes.
2. Clean all interior surfaces with a soft brush. Dampen a soft cloth with undiluted white vinegar and wipe out the base to remove scale.
3. Rinse thoroughly with clean warm water to remove scale and cleaning solution.

##### Disinfecting Base

1. Pour 1/2 gallon of water and 1/2 teaspoon chlorine bleach into the base. Let solution stay for 20 minutes, carefully swishing every few minutes. Wet all surfaces normally exposed to water.
2. Empty base after 20 minutes. Rinse with water until bleach smell is gone. Allow unit to dry out completely.

**NOTE:** The water bottle should be cleaned in the same manner as the base. Rinse thoroughly with clean water after all steps are complete.

#### End of Season Maintenance

1. Follow "Bi-Weekly Maintenance" instructions at end of humidification season.
2. Remove filter.
3. Let humidifier dry completely before storing.
4. Store in cool, dry location.
5. Install a new filter in clean humidifier before next season begins.

**NOTE:** "Bi-Weekly Maintenance" procedure is also recommended if you do not plan to run the humidifier for one week or more.

## Troubleshooting

Trouble	Probable Cause	Remedy
Red power light and digital display not illuminated.	<ul style="list-style-type: none"> <li>No Power.</li> <li>Power button has not been depressed.</li> </ul>	<ul style="list-style-type: none"> <li>Check 120 volt power source.</li> <li>Press power button once to turn on.</li> </ul>
Fan not operating (Red power light and digital display is illuminated).	<ul style="list-style-type: none"> <li>ROOM humidity level is not 3% or more below SET humidity level.</li> </ul>	<ul style="list-style-type: none"> <li>Raise SET humidity level if desired.</li> </ul>
Fan running continuously.	<ul style="list-style-type: none"> <li>SET humidity level is 65%.</li> <li>ROOM humidity level has not reached 1% or more above SET humidity level.</li> </ul>	<ul style="list-style-type: none"> <li>A SET humidity percentage of 65% operates fan continuously. Adjust SET level between 25% - 60%.</li> <li>Continue to run until desired humidity level is achieved. This may take up to 48 hours initially.</li> </ul>
Poor evaporation of water.	<ul style="list-style-type: none"> <li>CK FILTER message flashing.</li> </ul>	<ul style="list-style-type: none"> <li>Change to a fresh new filter.</li> <li>NOTE: Local water varies from area to area and under certain conditions mineral will build up more rapidly in the filter.</li> </ul>
Bottle empties completely.	<ul style="list-style-type: none"> <li>This is normal for initial filling.</li> </ul>	<ul style="list-style-type: none"> <li>Refill bottle for maximum run time.</li> </ul>
Bottle continues to empty after complete filling.	<ul style="list-style-type: none"> <li>Air is entering water bottle.</li> </ul>	<ul style="list-style-type: none"> <li>Ensure fill cap is tight with no interfering debris.</li> <li>Check for leak in water bottle.</li> </ul>
Bottle not emptying.	<ul style="list-style-type: none"> <li>Base full of water.</li> </ul>	<ul style="list-style-type: none"> <li>The base will hold the contents of water bottle (1.9 gallons). Continue to run humidifier to deplete water from base.</li> </ul>
CK FILTER message does not appear even when filter is dirty or humidifier performance is clearly reduced.	<ul style="list-style-type: none"> <li>A loss of power has caused the CK FILTER message to prematurely reset.</li> </ul>	<ul style="list-style-type: none"> <li>Replace filter.</li> </ul>
Fan operating slower than speed registered on digital display.	<ul style="list-style-type: none"> <li>Humidifier is in DRY OUT mode.</li> </ul>	<ul style="list-style-type: none"> <li>Humidifier automatically switches fan speed to WHISPER when DRY OUT mode message is displayed.</li> </ul>
Humidifier not shutting off during DRY OUT mode.	<ul style="list-style-type: none"> <li>Filter not dry.</li> </ul>	<ul style="list-style-type: none"> <li>During DRY OUT mode the humidifier will continue to run on WHISPER speed as required for a 2 hour period.</li> </ul>

# Repair Parts

---

## Parts List for Kenmore Humidifier Model No. 758.154120

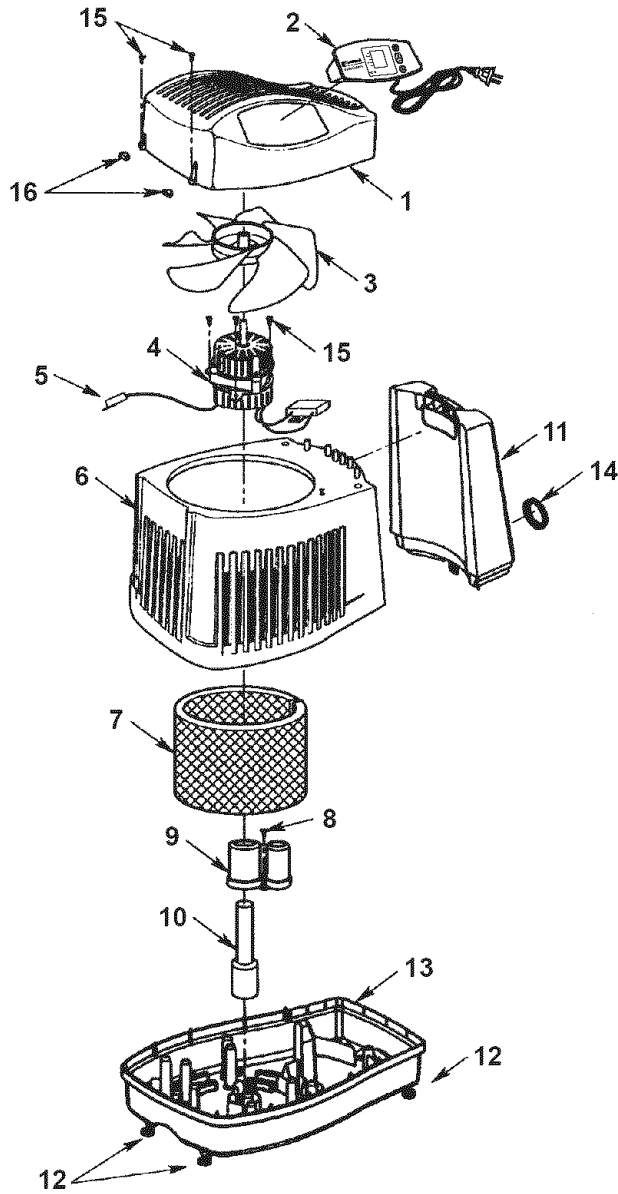

**Parts List for Kenmore Humidifier**  
**Model No. 758.154120**  
 Always order by part number - Not by key number

Key No	Part No.	Description
1	830487	Housing, Upper
2	831341	• Assembly, Control
3	829821	• Blade, Fan
4	830778	• Motor
5	828854	Switch, Micro
6	830489	Housing, Lower
7	32-14906	† Filter
8	829815	* Screw, Pan Hd. Ty. AB #6 x 1/2 SS
9	830496-2	Support, Float
10	829816	Float, Reservoir
11	830537	Bottle, Includes Key #15
12	829812	Casters (Includes 4)
13	830484-2	Base
14	824690-2	Cap, Fill
15	829805	Screw, Pan Hd. Trx. Hi-Lo #6 x 3/4
16	830587	Cap, Screw
17	SP6592	Owner's Manual (not shown)

- \* Standard Hardware Item - May be purchased locally
- † Stock item - May be secured through the Hardware Department of most Sears retail stores.
- Any attempt to repair the control assembly or motor may create a hazard unless repair is done by a qualified service technician. Repair service is available at your nearest Sears store.

# Get it fixed, at your home or ours!

## Your Home

For repair – **in your home** – of **all** major brand appliances, lawn and garden equipment, or heating and cooling systems, **no matter who made it, no matter who sold it!**

For the replacement parts, accessories and owner's manuals that you need to do-it-yourself.

For Sears professional installation of home appliances and items like garage door openers and water heaters.

**1-800-4-MY-HOME®**  
(1-800-469-4663)  
[www.sears.com](http://www.sears.com)

Anytime, day or night  
(U.S.A. and Canada)  
[www.sears.ca](http://www.sears.ca)

## Our Home

For repair of carry-in products like vacuums, lawn equipment, and electronics, call or go on-line for the nearest **Sears Parts and Repair Center.**

**1-800-488-1222** Anytime, day or night (U.S.A. only)  
[www.sears.com](http://www.sears.com)

To purchase a protection agreement (U.S.A.) or maintenance agreement (Canada) on a product serviced by Sears:

**1-800-827-6655** (U.S.A.)

**1-800-361-6665** (Canada)

Para pedir servicio de reparación a domicilio, y para solicitar piezas:

**1-888-SU-HOGAR<sup>SM</sup>**  
(1-888-784-6427)

Au Canada pour service en français:

**1-800-LE-FOYER<sup>MC</sup>**  
(1-800-533-6937)  
[www.sears.ca](http://www.sears.ca)



© Sears, Roebuck and Co.

® Registered Trademark / ™ Trademark / <sup>SM</sup> Service Mark of Sears, Roebuck and Co.

® Marca Registrada / ™ Marca de Fábrica / <sup>SM</sup> Marca de Servicio de Sears, Roebuck and Co.

<sup>MC</sup> Marque de commerce / <sup>MD</sup> Marque déposée de Sears, Roebuck and Co.

Part No. SP6592

Form No. SP6592-1

Printed in Canada 07/06