

This Owner's Manual is provided and hosted by Appliance Factory Parts.

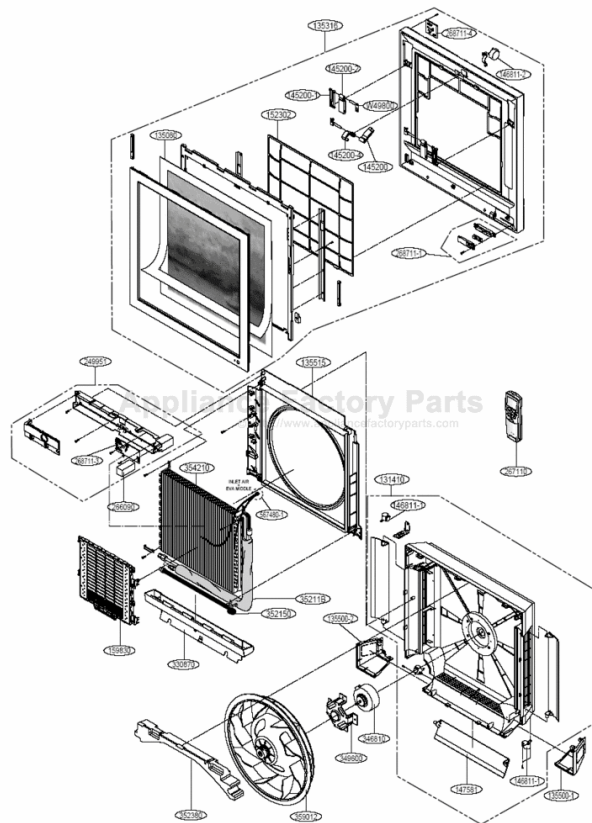

LG LAN091HNP Owner's Manual

[Shop genuine replacement parts for LG LAN091HNP](#)



[Find Your LG Air Conditioner Parts - Select From 2330 Models](#)

----- Manual continues below part list -----

Available Replacement Parts for LG LAN091HNP

AKB74375404	Ac Remote Control Akb74375404
5983A25015A	Air Cleaner Filter Assembly
5230A20069B	Air Filter
6871A20921A	Pcb Assembly
4520A30097A	Link
6871A20363G	Sub Pcb Assembly
4681A20042G	Motor Assembly,dc,stepping
EBG61107002	Ntc Thermistor Assembly

Universal Air Conditioner

SVC MANUAL(Exploded View)

MODEL : LAN126HNP(ASNH121F2G1)	LAU126HNP(ASUH121FUG1)
LAN096HNP(ASNH091F2G1)	LAU096HNP(ASUH091FUG1)
LAN091CNP (ASNC091F2G0)	LAU091CNP (ASUC091FUG0)
LAN121CNP (ASNC121F2G0)	LAU121CNP (ASUC121FUG0)
LAN091HNP (ASNH091F2G0)	LAU091HNP (ASUH091FUG0)
LAN121HNP (ASNH121F2G0)	LAU121HNP (ASUH121FUG0)
LA090CPI (ASNC091F2G0)	LA090CPO (ASUC091FUG0)
LA120CPI (ASNC091F2G0)	LA120CPO (ASUC091FUG0)
LA090HPI (ASNH091F2G0)	LA090HPO (ASUH091FUG0)
LA120HPI (ASNH121F2G0)	LA120HPO (ASUH121FUG0)

CAUTION

Before Servicing the unit, read the safety precautions in General SVC manual.
Only for authorized service personnel.

TABLE OF CONTENTS

Safety Precautions	3
Dimensions	9
Symbols Used in this Manual	9
Indoor Unit	9
Outdoor Unit	10
Product Specifications	11
Installation	13
Installation Parts	13
Installation Tools	13
Installation Map	14
Confirm the Refrigerant	15
Select the best Locations	16
Piping Length and Elevation	17
Preparing Work for Installation	18
Fixing Indoor Unit	19
Flaring work and connection of piping	20
Flaring work	20
Connection of piping-Indoor	21
Connection of the drain hose	22
Connection of piping-Outdoor	24
Connecting the cable between indoor unit and outdoor unit	25
Connect the cable to the Indoor unit	25
Connection method of the connecting cable(Example)	26
Checking the drainage and forming the pipings	27
Checking the drainage	28
Forming the piping	29
AIR PURGING	30
Air purging	30
Charging	32
Panel front assembly	33
Test running	34
How to replace picture & photograph	36
Operation	37
Functions	37
The function of main control	38
Display Function	44
Self-diagnosis Function	44
Remote Control Operations	45
Disassembly	46
Indoor Unit	46
Schematic Diagram	48
Heat Pump/Cooling Only Series(Indoor Unit)	48
Heat Pump Series (Outdoor Unit)	49
INDOOR UNIT P.W.B. ASSEMBLY	50
OUTDOOR UNIT P.W.B. ASSEMBLY	51
DISPLAY P.W.B. ASM	52
Wiring Diagram	53
Troubleshooting Guide	55
Refrigeration Cycle Diagram	55
Pipe length and the elevation	56
3-way Valve	57
Cycle Parts	63
Electronic Parts	64
Exploded View	73

Safety Precautions

To prevent injury to the user or other people and property damage, the following instructions must be followed.

■ Incorrect operation due to ignoring instruction will cause harm or damage. The seriousness is classified by the following indications.

⚠ WARNING This symbol indicates the possibility of death or serious injury.

⚠ CAUTION This symbol indicates the possibility of injury or damage to properties only.

■ Meanings of symbols used in this manual are as shown below.

	Be sure not to do.
	Be sure to follow the instruction.

⚠ WARNING

■ Installation

Do not use damaged power cords, plugs, or a loose socket.

- There is risk of fire or electric shock.

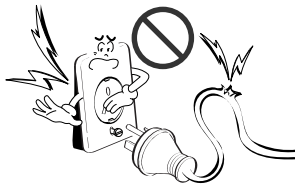

For electrical work, contact the dealer, seller, a qualified electrician, or an Authorized Service Center.

- There is risk of fire or electric shock.



Always use the power plug and socket with the ground terminal.

- There is risk of electric shock.

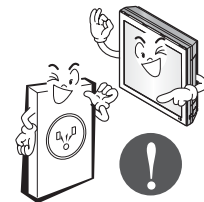

Install the panel and the cover of control box securely.

- There is risk of fire or electric shock.

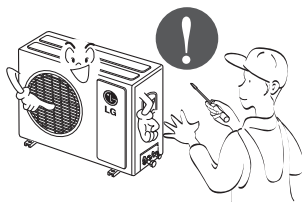

Do not modify or extend the power cord.

- There is risk of fire or electric shock.

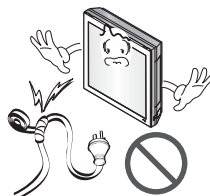

Do not install, remove, or re-install the unit by yourself (customer).

- There is risk of fire, electric shock, explosion, or injury.

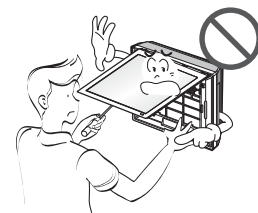

Safety Precautions

Be cautious when unpacking and installing the product.

- Sharp edges could cause injury. Be especially careful of the case edges and the fins on the condenser and evaporator.

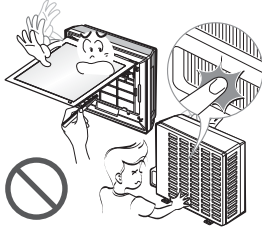

For installation, always contact the dealer or an Authorized Service Center.

- There is risk of fire, electric shock, explosion, or injury.



Do not install the product on a defective installation stand.

- It may cause injury, accident, or damage to the product.

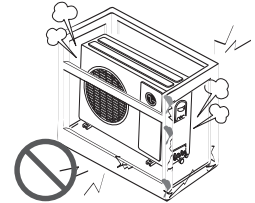

Be sure the installation area does not deteriorate with age.

- If the base collapses, the air conditioner could fall with it, causing property damage, product failure, and personal injury.

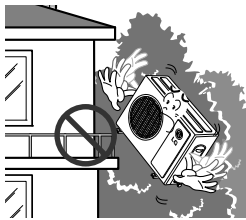

Do not let the air conditioner run for a long time when the humidity is very high and a door or a window is left open.

- Moisture may condense and wet or damage furnishings.



Operation

Take care to ensure that power cords could not be pulled out or damaged during operation.

- There is risk of fire or electrical shock.

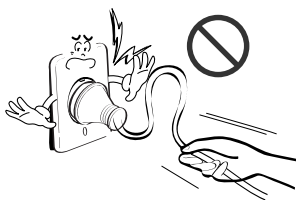

Do not place anything on the power cord.

- There is risk of fire or electric shock.

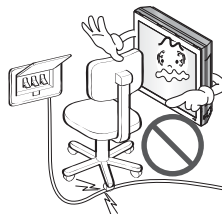

Do not turn the air-conditioner ON or OFF by plugging or unplugging the power plug.

- There is risk of fire or electrical shock.



Use a dedicated outlet for this appliance.

- There is risk of fire or electrical shock.

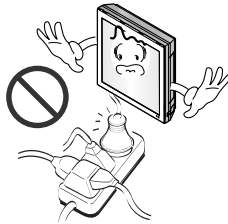

Grasp the plug to remove the cord from the outlet. Do not touch it with wet hands.

- There is risk of fire or electrical shock.



Do not place a heater or other appliances near the power cable.

- There is risk of fire and electric shock.

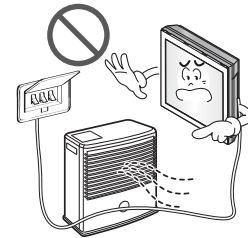

Do not allow water to run into electric parts.

- It may cause There is risk of fire, failure of the product, or electric shock.

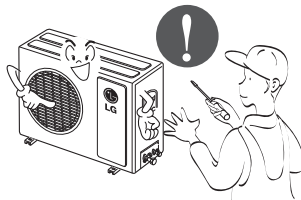

Do not store or use flammable gas or combustibles near the air conditioner.

- There is risk of fire or failure of product.



Do not use the product in a tightly closed space for a long time.

- Oxygen deficiency could occur.

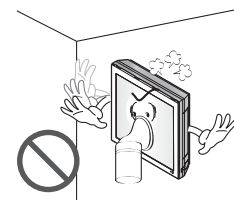

When flammable gas leaks, turn off the gas and open a window for ventilation before turn the product on. DO NOT use the telephone or turn switches on or off.

- There is risk of explosion or fire.

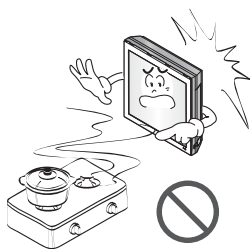

Unplug the unit if strange sounds, odors, or smoke comes from it.

- There is risk of electrical shock or fire



Stop operation and close the window in storm or hurricane. If possible, remove the air conditioner from the window before the hurricane arrives.

- There is risk of property damage, failure of product, or electric shock.

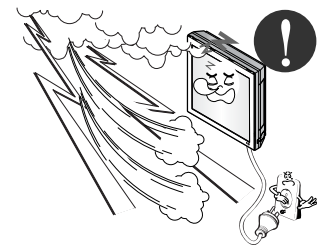

Safety Precautions

Do not open the inlet grill of the product during operation. (Do not touch the electrostatic filter, if the unit is so equipped.)

- There is risk of physical injury, electric shock, or product failure.

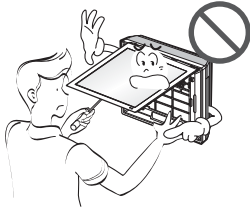

When the product is soaked (flooded or submerged), contact an Authorized Service Center.

- There is risk of fire or electric shock.



Ventilate the product from time to time when operating it together with a stove, etc.

- There is risk of fire or electrical shock.

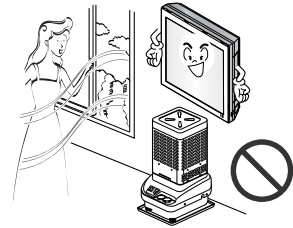

Unplug the appliance before performing cleaning or maintenance.

- There is risk of electrical shock.

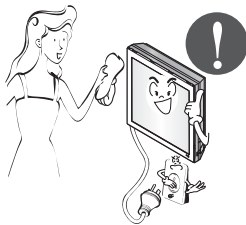

When the product is not be used for a long time, disconnect the power supply plug or turn off the breaker.

- There is risk of product damage or failure, or unintended operation.

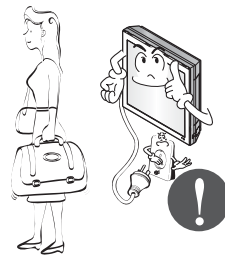

Take care to ensure that nobody could step on or fall onto the outdoor unit.

- This could result in personal injury and product damage.



CAUTION

Installation

Always check for gas (refrigerant) leakage after installation or repair of product.

- Low refrigerant levels may cause failure of product.

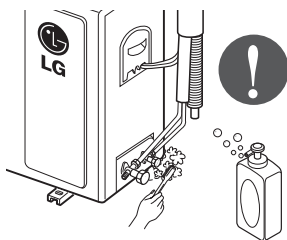

Install the drain hose to ensure that water is drained away properly.

- A bad connection may cause water leakage.

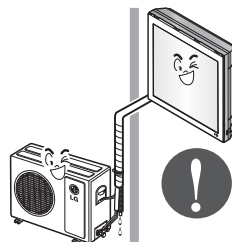

Keep level even when installing the product.

- To avoid vibration or water leakage.

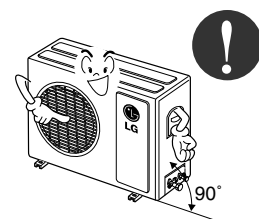

Do not install the product where the noise or hot air from the outdoor unit could damage the neighborhoods.

- It may cause a problem for your neighbors.

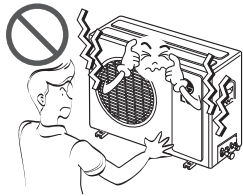

Use two or more people to lift and transport the air conditioner.

- Avoid personal injury.

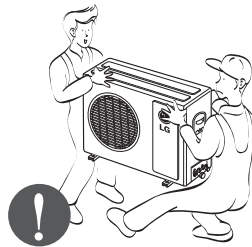

Do not install the product where it will be exposed to sea wind (salt spray) directly.

- It may cause corrosion on the product. Corrosion, particularly on the condenser and evaporator fins, could cause product malfunction or inefficient operation.

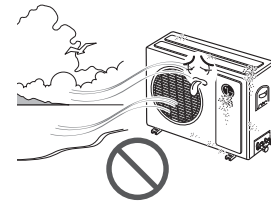

Operation

Do not direct airflow at room occupants. (Don't sit in the draft.)

- This could damage your health.



Do not use the product for special purposes, such as preserving foods, works of art, etc. It is a consumer air conditioner, not a precision refrigeration system.

- There is risk of damage or loss of property.

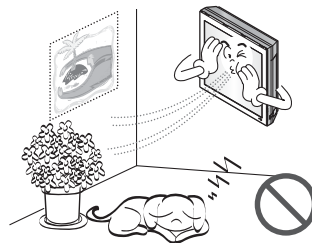

Do not block the inlet or outlet of air flow.

- It may cause product failure.

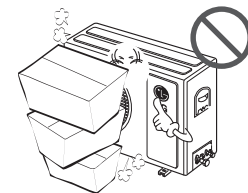

Use a soft cloth to clean. Do not use harsh detergents, solvents, etc.

- There is risk of fire, electric shock, or damage to the plastic parts of the product.

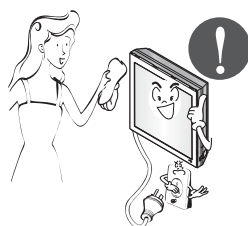

Do not touch the metal parts of the product when removing the air filter. They are very sharp!

- There is risk of personal injury.

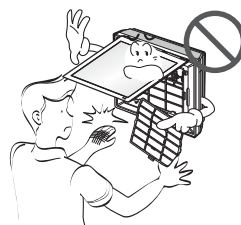

Do not step on or put anything on the product. (outdoor units)

- There is risk of personal injury and failure of product.

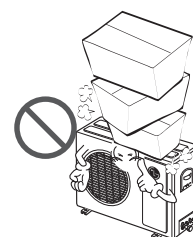

Safety Precautions

Always insert the filter securely. Clean the filter every two weeks or more often if necessary.

- A dirty filter reduces the efficiency of the air conditioner and could cause product malfunction or damage.

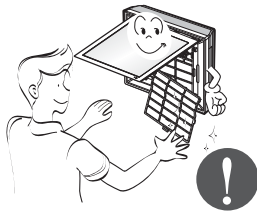

Do not insert hands or other objects through the air inlet or outlet while the air conditioner is plugged in.

- There are sharp and moving parts that could cause personal injury.

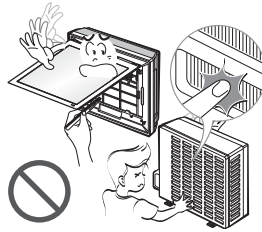

Do not drink the water drained from the unit.

- It is not sanitary and could cause serious health issues.

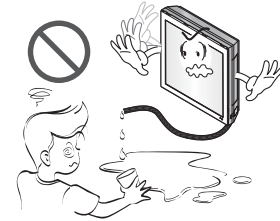

Use a firm stool or ladder when cleaning or maintaining the air conditioner.

- Be careful and avoid personal injury.

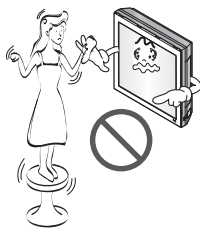

Replace the all batteries in the remote control with new ones of the same type. Do not mix old and new batteries or different types of batteries.

- There is risk of fire or explosion

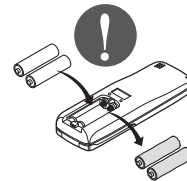

Disuse

Do not recharge or disassemble the batteries. Do not dispose of batteries in a fire.

- They may burn or explode.

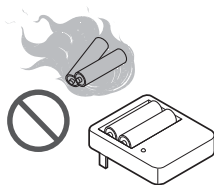

If the liquid from the batteries gets onto your skin or clothes, wash it well with clean water. Do not use the remote if the batteries have leaked.

- The chemicals in batteries could cause burns or other health hazards.



Dimensions

Symbols Used in this Manual



This symbol alerts you to the risk of electric shock.



This symbol alerts you to hazards that could cause harm to the air conditioner.

NOTICE

This symbol indicates special notes.

Indoor Unit

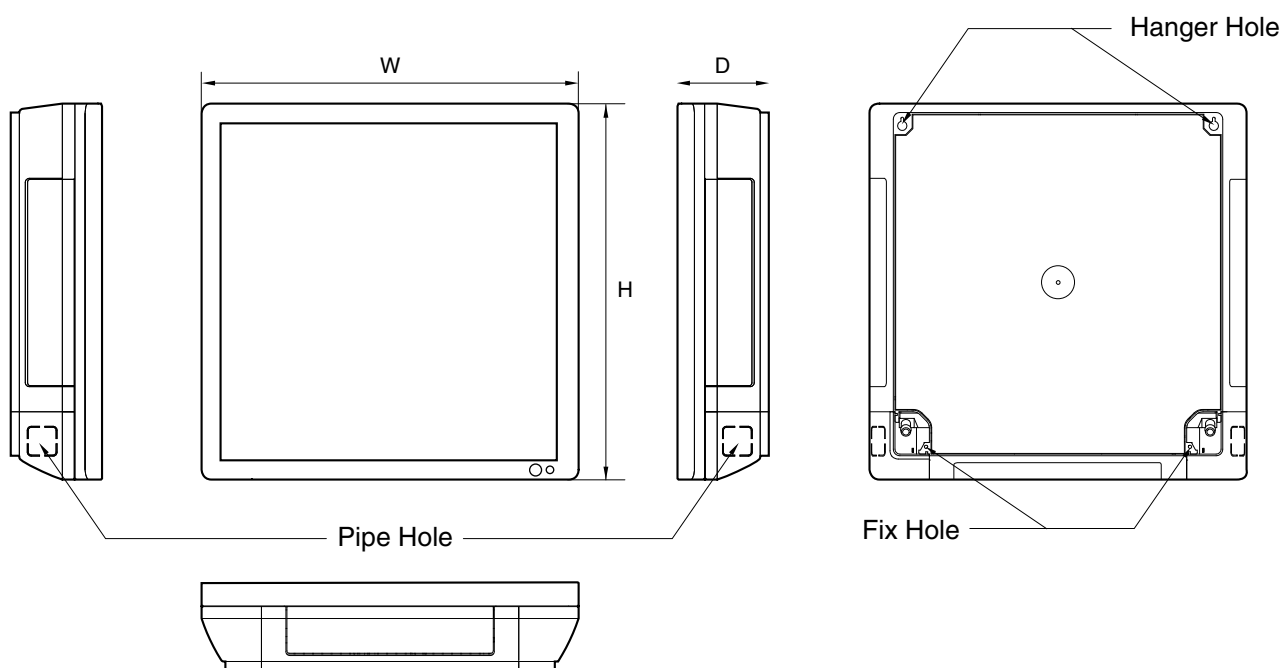

Model		INDOOR UNIT
Dimension		
W	mm(inch)	600(23.6)
H	mm(inch)	600(23.6)
D	mm(inch)	146(5.7)

Outdoor Unit

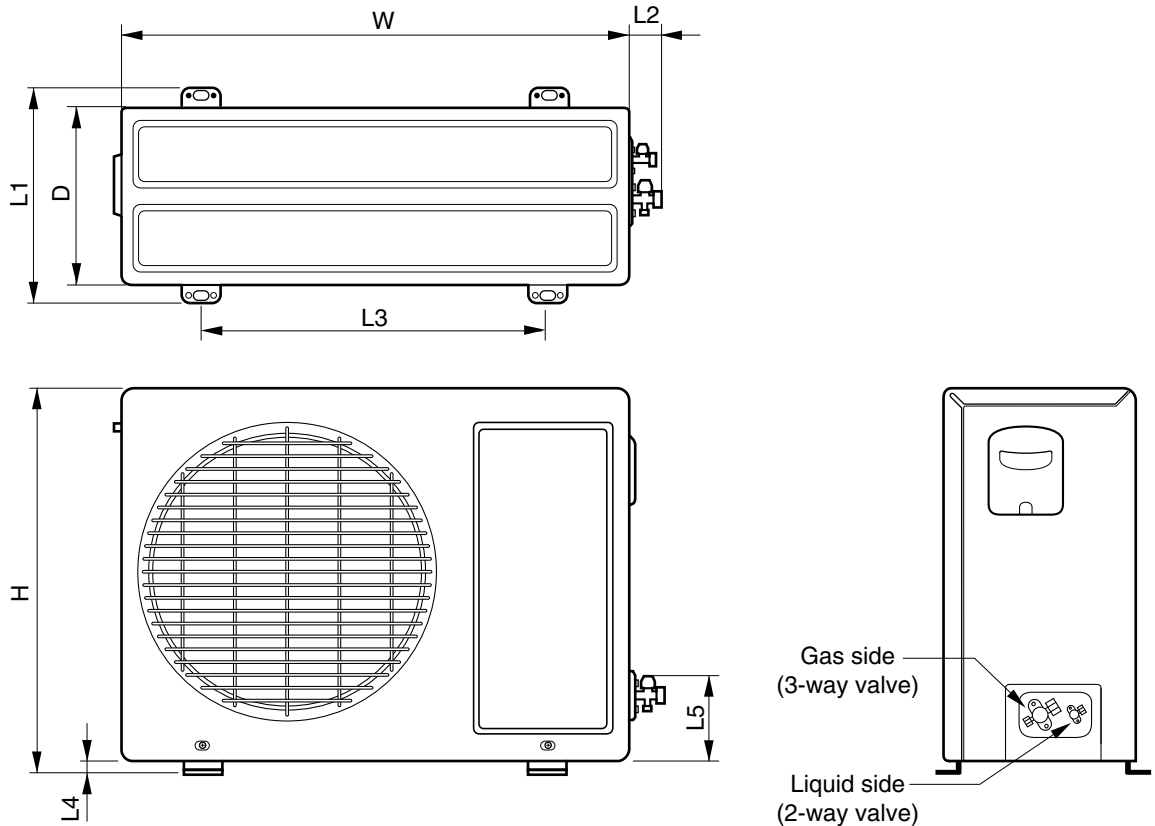

DIM	MODEL	
	unit	9k, 12k Models
W	mm	770(30.3)
H	mm	540(21.3)
D	mm	245(9.6)
L1	mm	285(11.2)
L2	mm	64(2.5)
L3	mm	518(20.4)
L4	mm	10(0.4)
L5	mm	100(3.9)

Product Specifications

Models			AS-C091F2G0(LA091CNP) AS-C091F2G0(LA090CP)	AS-C121F2G0(LA121CNP) AS-C121F2G0(LA120CP)	AS-H091F2G0(LA091HNP) AS-H091F2G0(LA090HP)	AS-H121F2G0(LA121HNP) AS-H121F2G0(LA120HP)	
Cooling Capacity (Min~Rating~Max)	kW		2.87	3.37	2.87	3.37	
	Btu/h		9,800	11,500	9,800	11,500	
Heating Capacity (Min~Rating~Max)	kW		-	-	2.87	3.37	
	Btu/h		-	-	9,800	11,500	
Power Input	Cooling/Heating	W	980	1,100	980/980	1,100/1,100	
Running Current	Cooling/Heating	A	9.4	10	9.4/9.4	10/10	
Starting Current	Cooling/Heating	A	57.0	57.0	57.0/57.0	57.0/57.0	
EER	W/W		2.93	3.06	2.93	3.06	
	Btu/h.W		10.0	10.5	10.0	10.5	
COP	W/W		-	-	2.93	3.06	
Power Supply	Ø / V / Hz		1/115/60	1/115/60	1/115/60	1/115/60	
Power Factor	%		90.7	95.7	90.7	95.7	
Air Flow Rate	Indoor,Max	m ³ /min(cfm)	9.3(330)	9.3(330)	9.3(330)	9.3(330)	
	Outdoor,Max	m ³ /min(cfm)	25(883)	25(883)	25(883)	25(883)	
Moisture Removal	l/h		1.4	1.4	1.4	1.4	
Sound Level	Indoor,H/M/L	dB(A)+3	41/35/29	41/35/29	41/35/29	41/35/29	
	Outdoor,Max	dB(A)+3	48	48	48	48	
Refrigerant & Charge(at 7.5m)	g(oz)		R410A, 900(31.8)	R410A, 900(31.8)	R410A, 900(31.8)	R410A, 900(31.8)	
Compressor	Type		Rotary	Rotary	Rotary	Rotary	
	Model		GK113CAA	GK113CAA	GK113CAA	GK113CAA	
	Motor Type		PSC	PSC	PSC	PSC	
	Oil Type		FVC68D(PVE)	FVC68D(PVE)	FVC68D(PVE)	FVC68D(PVE)	
	Oil Charge	cc	330	330	330	330	
	O.L.P Name		MRA12053-12027	MRA12053-12027	MRA12053-12027	MRA12053-12027	
Fan(Indoor)	Type		Turbo Fan	Turbo Fan	Turbo Fan	Turbo Fan	
	Motor Output	W	24	24	24	24	
Fan(outdoor)	Type		Propeller	Propeller	Propeller	Propeller	
	Motor Type		AC Induction	AC Induction	AC Induction	AC Induction	
	Motor Output	W	27	27	27	27	
Circuit Breaker*	A		20	20	20	20	
Power Supply Cable	No.*mm ²		3*2.5	3*2.5	3*2.5	3*2.5	
Power and Transmission Cable	No.*mm ² +No.mm ²		4*0.75	4*0.75	4*0.75	4*0.75	
Piping Connections	Liquid Side	mm(in)	6.35(1/4)	6.35(1/4)	6.35(1/4)	6.35(1/4)	
	Gas Side	mm(in)	12.7(1/2)	12.7(1/2)	12.7(1/2)	12.7(1/2)	
Drain Hose	O.D., I.D		21.5, 16(0.85, 0.63)	21.5, 16(0.85, 0.63)	21.5, 16(0.85, 0.63)	21.5, 16(0.85, 0.63)	
Dimension	Indoor(W*H*D)	mm	600*600*146	600*600*146	600*600*146	600*600*146	
		inch	23.62*23.62*5.75	23.62*23.62*5.75	23.62*23.62*5.75	23.62*23.62*5.75	
	Outdoor(W*H*D)	mm	770*540*245	770*540*245	770*540*245	770*540*245	
		inch	30.31*21.26*9.65	30.31*21.26*9.65	30.31*21.26*9.65	30.31*21.26*9.65	
Net Weight	Indoor	kg(lbs)	15(33.1)	15(33.1)	15(33.1)	15(33.1)	
	Outdoor	kg(lbs)	32(70.5)	32(70.5)	32(70.5)	32(70.5)	
Tool Code(Chassis)	Indoor + Outdoor		SF + UL	SF + UL	SF + UL	SF + UL	
Functions	Temperature Control		Thermistor	Thermistor	Thermistor	Thermistor	
	Plasma Filter		○	○	○	○	
	Prefilter(washable/anti-fungus)		○	○	○	○	
	Auto Clean		○	○	○	○	
	CHAOS Wind(Auto Wind)		○	○	○	○	
	Steps, Fan/Cool/Heat		3/4	3/4	3/4/3	3/4/3	
	Airflow Direction Control(up&down)		Auto	Auto	Auto	Auto	
	Airflow Direction Control(left&right)		Auto	Auto	Auto	Auto	
	Remocon Type		Wireless LCD	Wireless LCD	Wireless LCD	Wireless LCD	
	Setting Temperature Range	Cooling	18 ~ 30	18 ~ 30	18 ~ 30	18 ~ 30	
		Heating	-	-	16 ~ 30	16 ~ 30	
	Auto Operation (Micom Control)		○	○	○	○	
	Auto Changeover (Micom Control)		○	○	○	○	
	Self Diagnosis		○	○	○	○	
	Timer		24h, On/Off	24h, On/Off	24h, On/Off	24h, On/Off	
	Sleep Operation		○	○	○	○	
	Soft Dry Operation		○	○	○	○	
	Restart Delay(minute)		3	3	3	3	
	Deice Control(Defrost)		-	-	○	○	
	Hot Start		-	-	○	○	
	Jet Cool		○	○	○	○	
	Low Ambient Operation		-	-	-	-	
	Special Function		-	-	-	-	
	Network Functions	Dry Contact		-	-	-	-
		Network Solution(LGAP)		-	-	-	-
		PI485		-	-	-	-

Note:

○ : Applied, - : No relation

* For circuit breaker rating, please conform to local standards wherever necessary.

※ Some of functions are slightly different depending upon models.

※ The specification may be subject to change without notice for purpose of improvement.

Product Specifications

Models		AS-H091F2G1 (LA096HNP)	AS-H121F2G1 (LA126HNP)	
Cooling Capacity (Min~Rating~Max)	kW	2.9	3.37	
	Btu/h	9,900	11,500	
Heating Capacity (Min~Rating~Max)	kW	2.9	3.22	
	Btu/h	9,900	11,000	
Power Input	Cooling/Heating	W	1,100/1,070	
Running Current	Cooling/Heating	A	9.4/9.4	
Starting Current	Cooling/Heating	A	57.0/57.0	
EER	W/W	2.63	2.93	
	Btu/h.W	9	10	
COP	W/W	2.71	2.93	
Power Supply	Ø / V / Hz	1/115/60	1/115/60	
Power Factor	%	90.7	95.7	
Air Flow Rate	Indoor,Max	m³/min(cfm)	9.3(330)	
	Outdoor,Max	m³/min(cfm)	25(883)	
Moisture Removal	l/h	1.4	1.4	
Sound Level	Indoor,H/M/L	dB(A)+3	43/35/29	
	Outdoor,Max	dB(A)+3	48	
Refrigerant & Charge(at 7.5m)	g(oz)	R410A, 900(31.8)	R410A, 900(31.8)	
Compressor	Type	Rotary	Rotary	
	Model	GK113CAA	GK113CAA	
	Motor Type	PSC	PSC	
	Oil Type	FVC68D(PVE)	FVC68D(PVE)	
	Oil Charge	cc	330	
	O.L.P Name	MRA12053-12027	MRA12053-12027	
Fan(Indoor)	Type	Turbo Fan	Turbo Fan	
	Motor Output	W	24	
Fan(outdoor)	Type	Propeller	Propeller	
	Motor Type	AC Induction	AC Induction	
	Motor Output	W	27	
Circuit Breaker*	A	20	20	
Power Supply Cable	No.*mm²	3*2.5	3*2.5	
Power and Transmission Cable	No.*mm²+No.mm²	4*0.75	4*0.75	
Piping Connections	Liquid Side	mm(in)	6.35(1/4)	
	Gas Side	mm(in)	12.7(1/2)	
Drain Hose	O.D , I.D	mm(in)	21.5,16(0.85,0.63)	
Dimension	Indoor(W*H*D)	mm	600*600*146	
		inch	23.62*23.62*5.75	
	Outdoor(W*H*D)	mm	770*540*245	
		inch	30.31*21.26*9.65	
Net Weight	Indoor	kg(lbs)	15(33.1)	
	Outdoor	kg(lbs)	32(70.5)	
Tool Code(Chassis)	Indoor + Outdoor	SF + UL	SF + UL	
Functions	Temperature Control	Thermistor	Thermistor	
	Plasma Filter	O	O	
	Prefilter(washable/anti-fungus)	O	O	
	Auto Clean	O	O	
	CHAOS Wind(Auto Wind)	O	O	
	Steps, Fan/Cool/Heat	2003-04-03	2003-04-03	
	Airflow Direction Control(up&down)	Auto	Auto	
	Airflow Direction Control(left&right)	Auto	Auto	
	Remocon Type	Wireless LCD	Wireless LCD	
	Setting Temperature Range	Cooling	18 ~ 30	18 ~ 30
		Heating	16 ~ 30	16 ~ 30
	Auto Operation (Micom Control)	O	O	
	Auto Changeover (Micom Control)	O	O	
	Self Diagnosis	O	O	
	Timer	24h, On/Off	24h, On/Off	
	Sleep Operation	O	O	
	Soft Dry Operation	O	O	
	Restart Delay(minute)	3	3	
	Deice Control(Defrost)	O	O	
	Hot Start	O	O	
	Jet Cool	O	O	
	Low Ambient Operation	-	-	
	Special Function	-	-	
Network Functions	Dry Contact	-	-	
	Network Solution(LGAP)	-	-	
	PI485	-	-	

Note:

O : Applied, - : No relation

* For circuit breaker rating, please conform to local standards wherever necessary.



※ Some of functions are slightly different depending upon models.

※ The specification may be subject to change without notice for purpose of improvement.





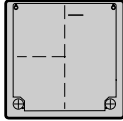

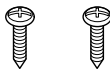
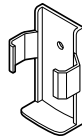

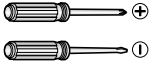

Installation

Read carefully, and then follow step by step.

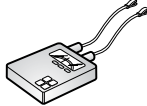
Installation Parts

Installation guide map	Type "A" screw and plastic anchor
	
Type "B" screw	Remote control holder
	

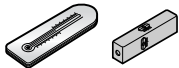
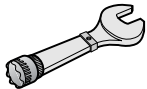
Installation Tools

Figure	Name	Figure	Name
	Screw driver		Ohmmeter
	Electric drill		Hexagonal wrench
	Measuring tape, Knife		Ammeter
	Hole core drill		Leak detector
	Spanner		Thermometer, Horizontal meter
	Torque wrench		Flaring tool set

Installation Map

NOTICE Installation parts you should purchase. (※)

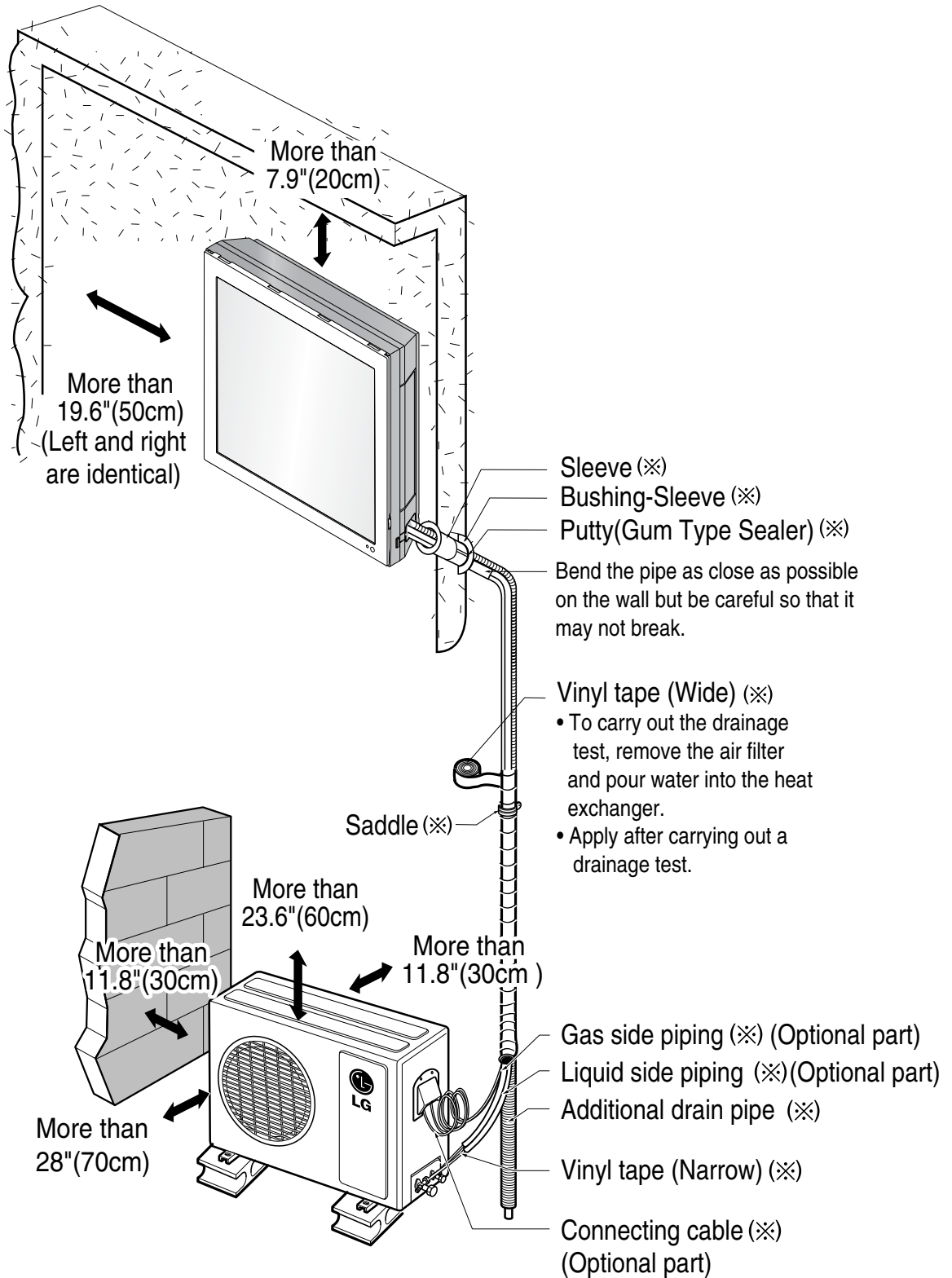

Confirm The Refrigerant

1. Check the quality label on the indoor and outdoor unit.
2. Make certain that the refrigerant is R-410A.

NOTICE

THIS PRODUCT CONTAINS R-410A REFRIGERANT

- 1) Different compressor oil
 - R-410A(Polyol ester) / R-22(Mineral).
 - Do not mix the existing mineral oil.
 - Do not apply used pipe, tools and gauges covered with the existing mineral oil.
- 2) Absorption of moisture
 - Compressor's oil has the high absorption rate of moisture.
- 3) Composition
 - R-410A(R32:R125=50:50wt%).

NOTE: Never mix with other refrigerants

Example : Split type 12,000 Btu/h

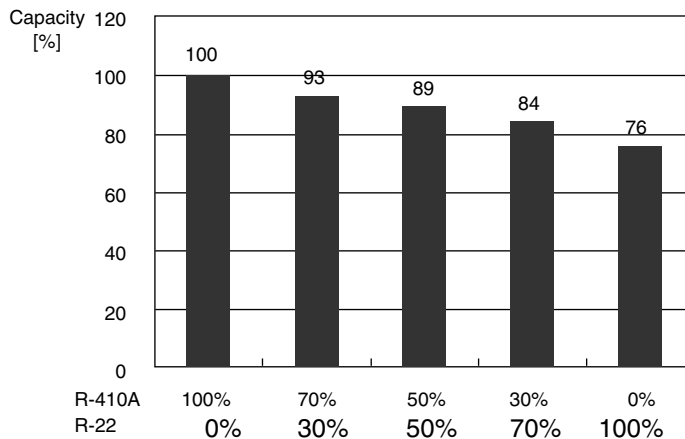

- 4) High pressure.
 - 1.6 times higher than R-22.
 - High Pressure refrigerant may cause personal injury.

	Boiling Pt.(°C)	Vapor pressure(25°C)(kg f/cnf)	Vapor density(25°C)(kg/m ²)
R-410A	-51.4	15.9	64
R-22	-40.8	9.6	44.4

Do not handle the pipe by yourself (customer) High-pressure refrigerant may cause personal injury.
 - manifold gauge ,charging and any piping tools must be dedicated to R-410A systems.

Select the best Location

Indoor unit

1. Do not have any heat or steam near the unit.
2. Select a place where there are no obstacles in front of the unit.
3. Make sure that condensation drainage can be conveniently routed away.
4. Do not install near a doorway.
5. Ensure that the interval between a wall and the left (or right) of the unit is more than 19.6"(50cm). The unit should be installed as high as possible on the wall, allowing a minimum of 7.9"(20cm) from ceiling.
6. Use a stud finder to locate studs to prevent unnecessary damage to the wall.

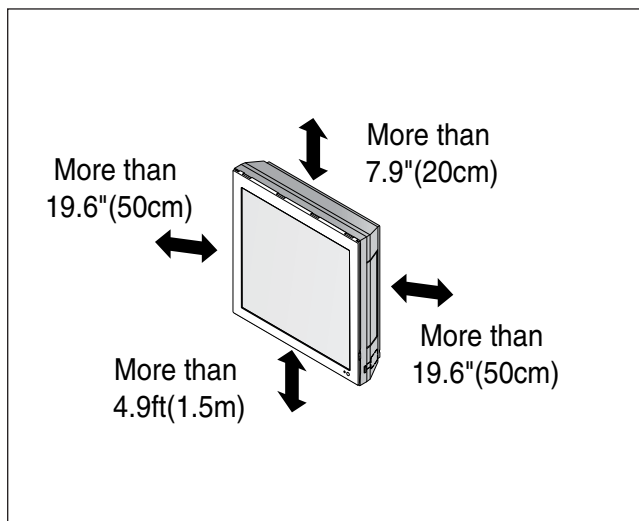

CAUTION: Install the indoor unit on the wall where the height from the floor is more than 4.9 feet(1.5 meters).

Outdoor unit

1. If an awning is built over the unit to prevent direct sunlight or rain exposure, make sure that heat radiation from the condenser is not restricted.
2. Ensure that the space around the back and sides is more than 11.8"(30cm). The front of the unit should have more than 28"(70cm) of space.
3. Do not place animals and plants in the path of the warm air.
4. Take the weight of the air conditioner into account and select a place where noise and vibration are minimum.
5. Select a place where the warm air and noise from the air conditioner do not disturb neighbors.

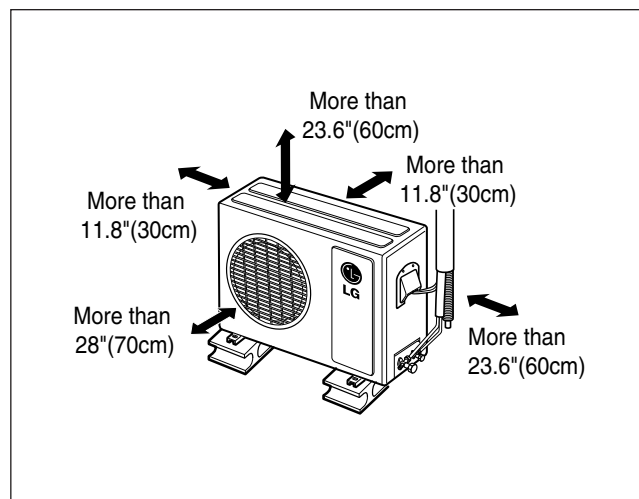

Rooftop Installations

If the outdoor unit is installed on a roof structure, be sure to level the unit. Ensure the roof structure and anchoring method are adequate for the unit location. Consult local codes regarding rooftop mounting.

If the outdoor unit is installed on roof structures or walls, this may result in excessive noise and vibration, and may be also classed as non serviceable installation.

Piping Length and Elevation

Capacity (Btu/h)	Pipe Size		Standard Length m(ft)	Max. Elevation ② m(ft)	Max. length ① m(ft)	Additional Refrigerant g/m(oz/ft)
	Suction	Evap				
9k, 12k	Ø12.7mm(1/2")	Ø6.35mm(1/4")	7.5(25)	7.5(25)	15(49)	20(0.22)

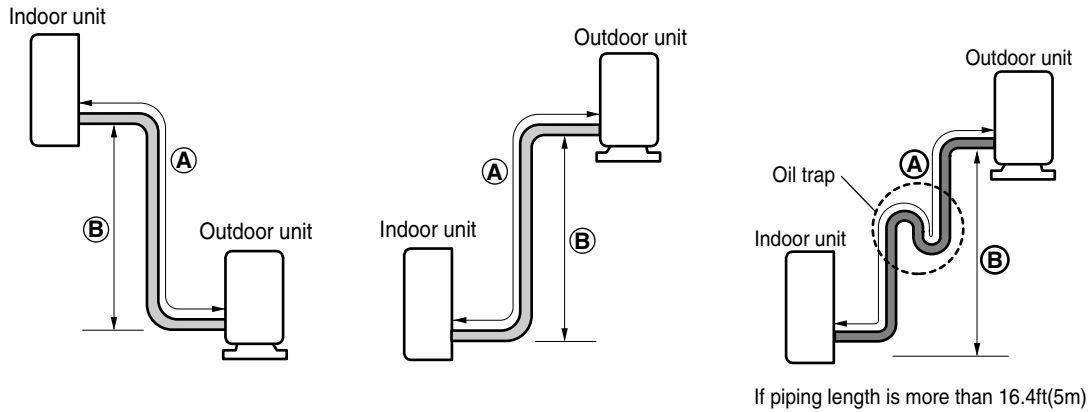

⚠ CAUTION: Capacity is based on standard length and maximum allowance length is on the basis of reliability. Oil trap should be installed every 16.4~23feets (5~7 meters).

Preparing Work for Installation

Open panel front

1. Pull the upper part of the front panel.
2. Lift up the panel.
3. To detach the front panel, remove the two screws at the lower part.
4. Detach the front panel from the body.
5. To detach the panel, disconnect the connector at the upper part.

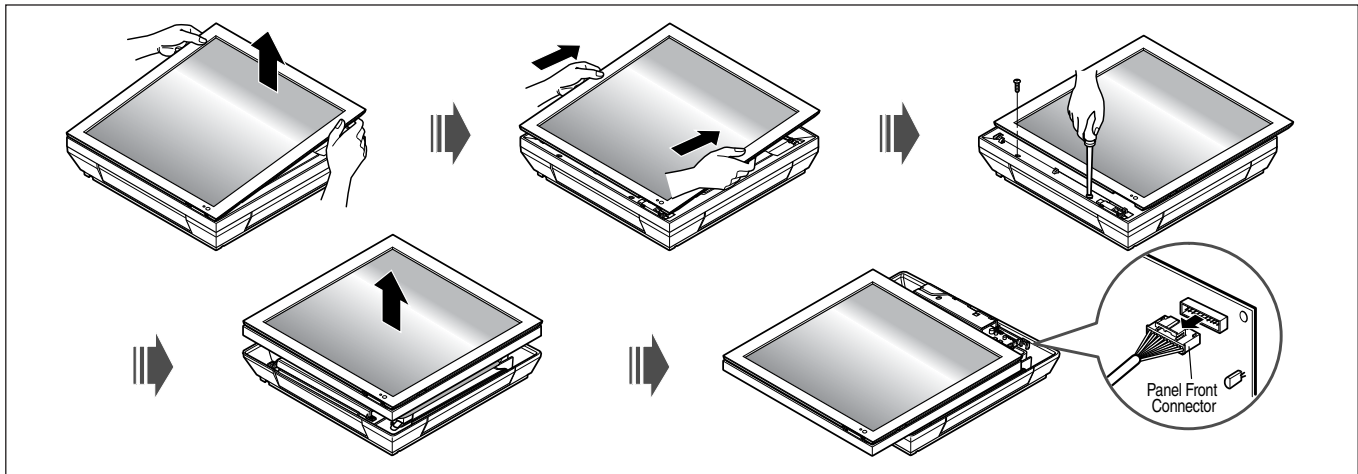

Cover pipe and cover side remove

1. Please remove the screw of the center tuning cover.
2. Pull up the side cover of desired connecting direction, then cover side is separated.
3. Pick the pipe hole of the side cover.

CAUTION: After removing the pipe hole, cut the burr for safety.

NOTICE When making pipe path through rear wall, you don't need to pick the pipe hole.

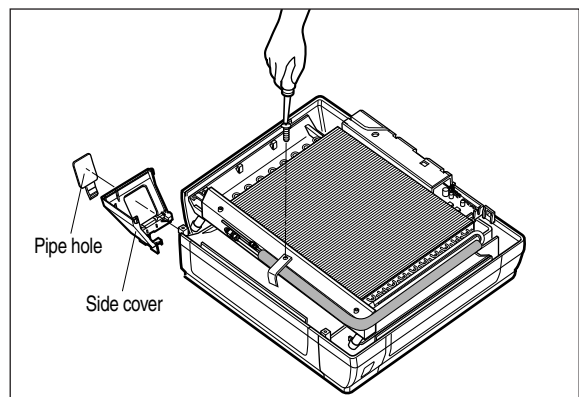

Drain hose junction

1. Remove the rubber stopple in the desired drain direction.
2. Insert drain hose into the handle of drain pan, and join drain hose and connecting hose according to the figure by.

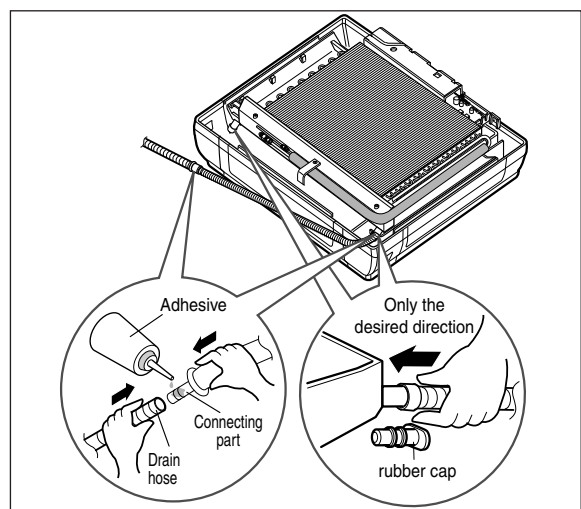

Fixing Indoor Unit

1. Attach an Installation guide map on the desired surface.

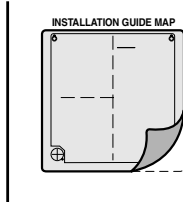

2. Look at suited horizon by horizontal meter on the horizontal setting line, and fix lightly the map by adhesive tape.

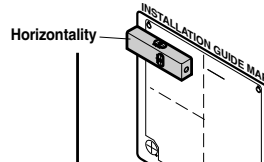

3. Make a hole with a diameter of 6mm and depth of 30-35mm by piercing a screw point.

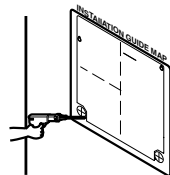

4. Drill the pierced part as a diameter of 50mm for connecting piping. (In case of piercing rear surface)

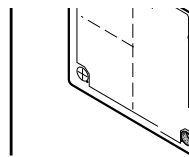

5. Drive the fore plastic anchors into drilled points.

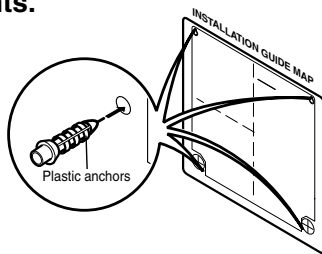

6. First, Drive the two points of the upper parts by screws. (Leave 10mm for hanging the product)

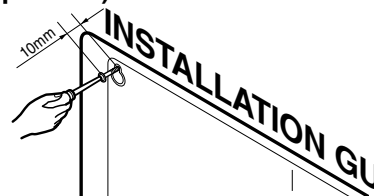

7. Hang the hole of product at the upper screws, and remove the map. (Falling attention)

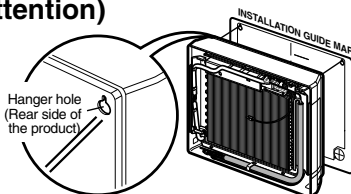

8. Drive the lower parts after facing the hole of product with plastic anchors, and fix completely the upper screws.

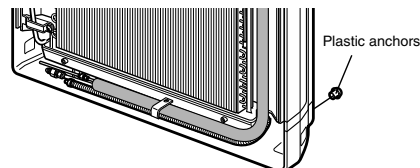

9. Check the fixed product with light power.

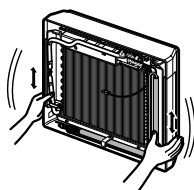

10. In case of nothing wrong, connect the pipe and the wire. (Refer to installation manual)

Drill a Hole in the Wall

- Drill the piping hole with a $\varnothing 50\text{mm}$ hole core drill. Drill the piping hole at either the right or the left with the hole slightly slanted to the outdoor side.

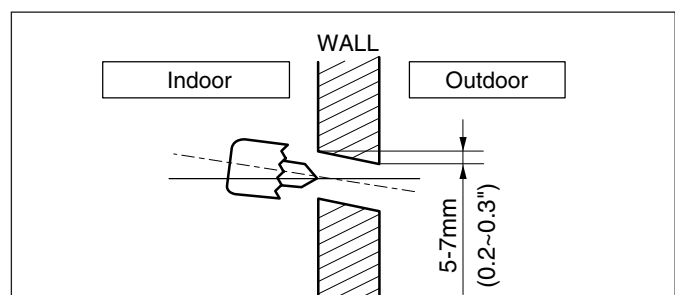

Flaring work and connection of piping

Flaring Work

Main cause for gas leakage is due to defect in flaring work. Carry out correct flaring work in the following procedure.

Cutting the pipes and the cable.

1. Use the piping kit accessory or the pipes purchased locally.
2. Measure the distance between the indoor and the outdoor unit.
3. Cut the pipes a little longer than measured distance.
4. Cut the cable 4.9ft(1.5m) longer than the pipe length.

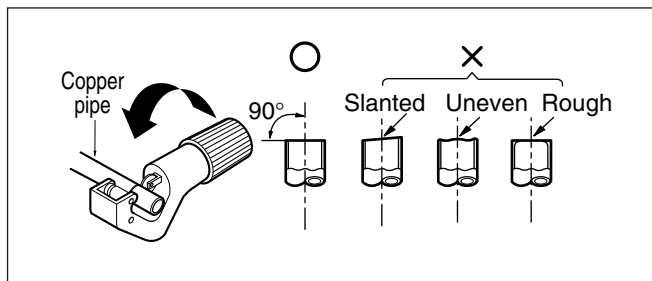

Removing burrs

1. Completely remove all burrs from the cut cross section of pipe/tube.
2. Put the end of the copper tube/pipe in a downward direction as you remove burrs in order to avoid dropping burrs into the tubing.

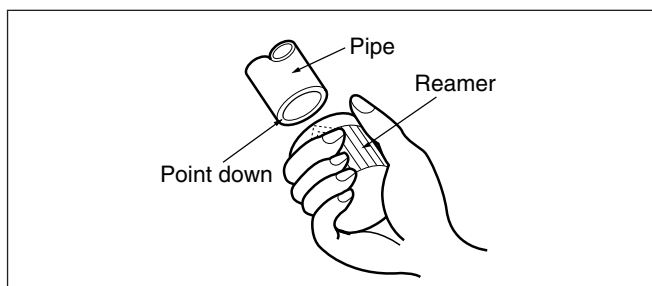

Putting nut on

- Remove flare nuts attached to indoor and outdoor unit, then put them on pipe/tube having completed burr removal.
(not possible to put them on after flaring work)

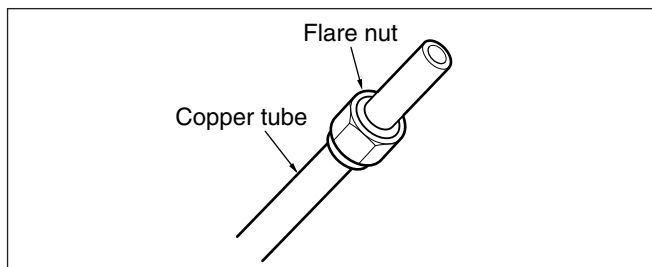

Flaring work

1. Firmly hold copper pipe in a die in the dimension shown in the table below.
2. Carry out flaring work with the flaring tool.

Outside diameter		A
mm	inch	mm
Ø6.35	1/4	1.1~1.3
Ø9.52	3/8	1.5~1.7
Ø12.7	1/2	1.6~1.8
Ø15.88	5/8	1.6~1.8
Ø19.05	3/4	1.9~2.1

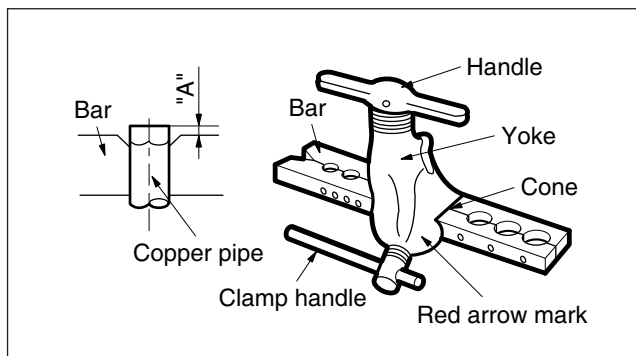

Check

1. Compare the flared work with the figure by.
2. If a flared section is defective, cut it off and do flaring work again.

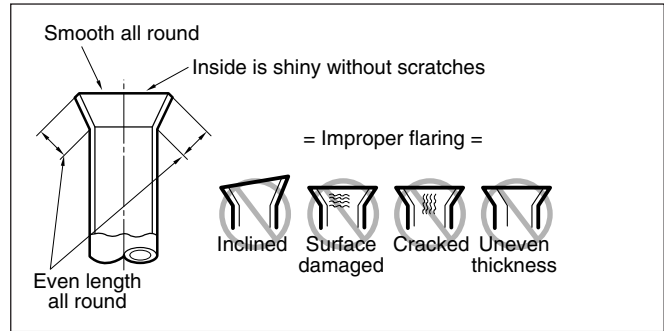

Connecting the Piping

Indoor

Preparing the indoor unit's piping and drain hose for installation through the wall.

1. Route the indoor tubing and the drain hose in the direction of rear left or right

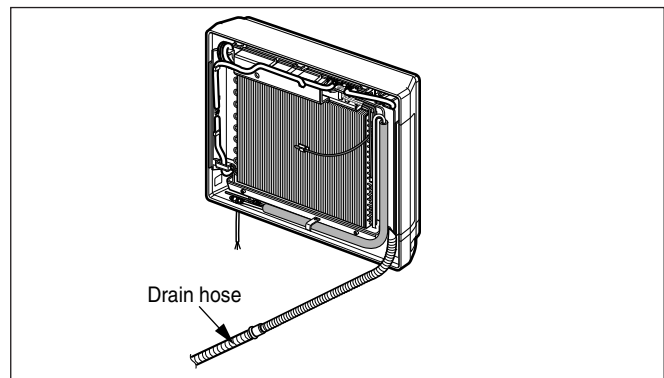

2. Tape the tubing, drain hose and the connecting cable. Be sure that the drain hose is located at the lowest side of the bundle. Locating at the upper side can cause drain pan to overflow inside the unit.

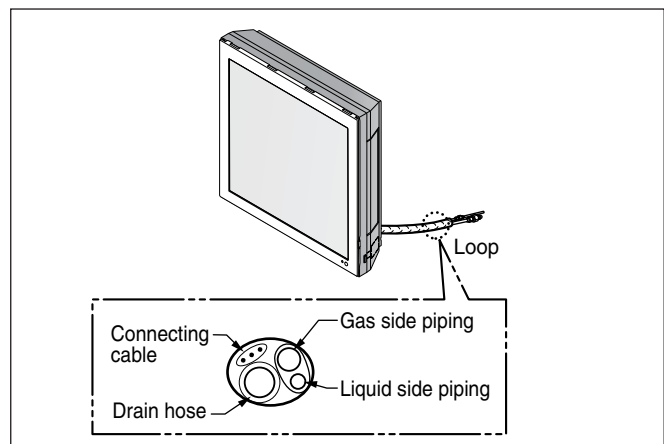

CAUTION: If the drain hose is routed inside the room, insulate the hose with an insulation material* so that dripping from "sweating" (condensation) will not damage furniture or floors.

*Foamed polyethylene or equivalent is recommended.

Connecting the piping with the indoor unit and drain hose with drain pipe

1. Align the center of the pipings and sufficiently tighten the flare nut by hand.
2. Tighten the flare nut with a wrench.

Outside diameter		Torque
mm	inch	
Ø6.35	1/4	180~250
Ø9.52	3/8	340~420
Ø12.7	1/2	550~660

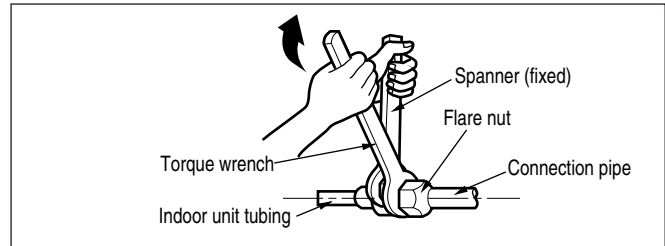
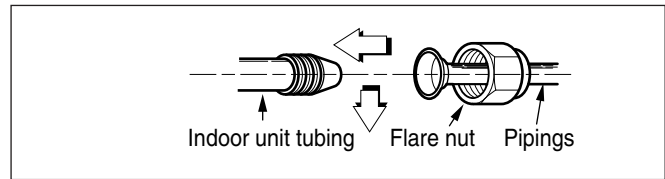

3. When extending the drain hose at the indoor unit, install the drain pipe.

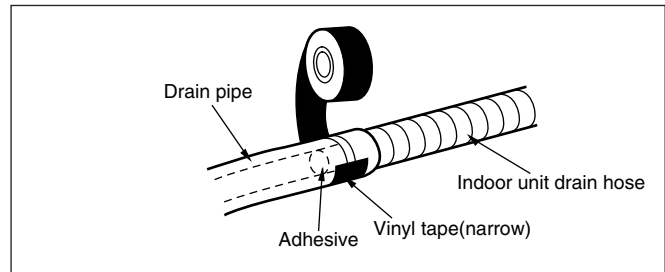

Wrap the insulation material around the connecting portion.

1. Overlap the connection pipe insulation material and the indoor unit pipe insulation material. Bind them together with vinyl tape so that there may be no gap.
2. Wrap the area which accommodates the rear piping housing section with vinyl tape.

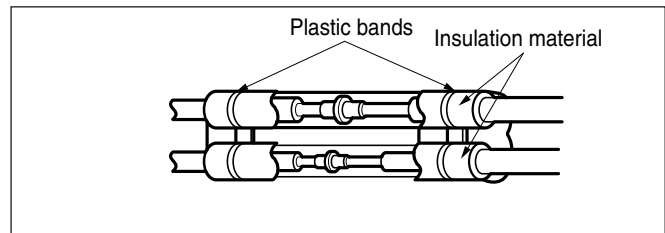

3. Bundle the piping and drain hose together by wrapping them with vinyl tape over the range within which they fit into the rear piping housing section.

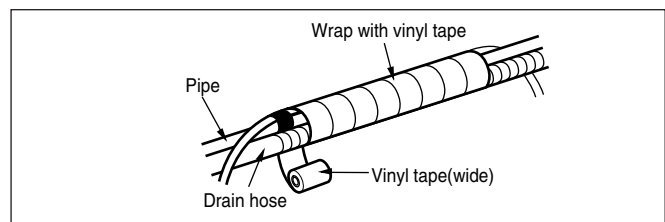
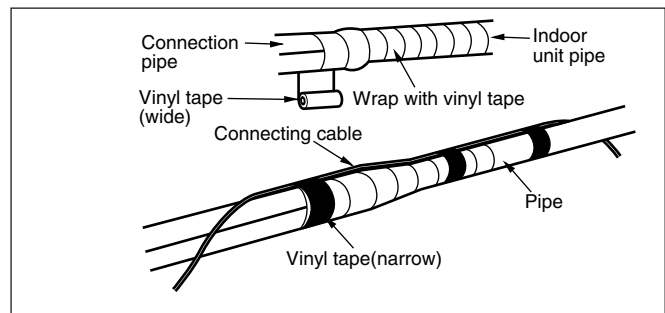

⚠ CAUTION: Installation Information
For right piping. Follow the instruction below.

Good case

- Press on the upper side of clamp and unfold the tubing to downward slowly.

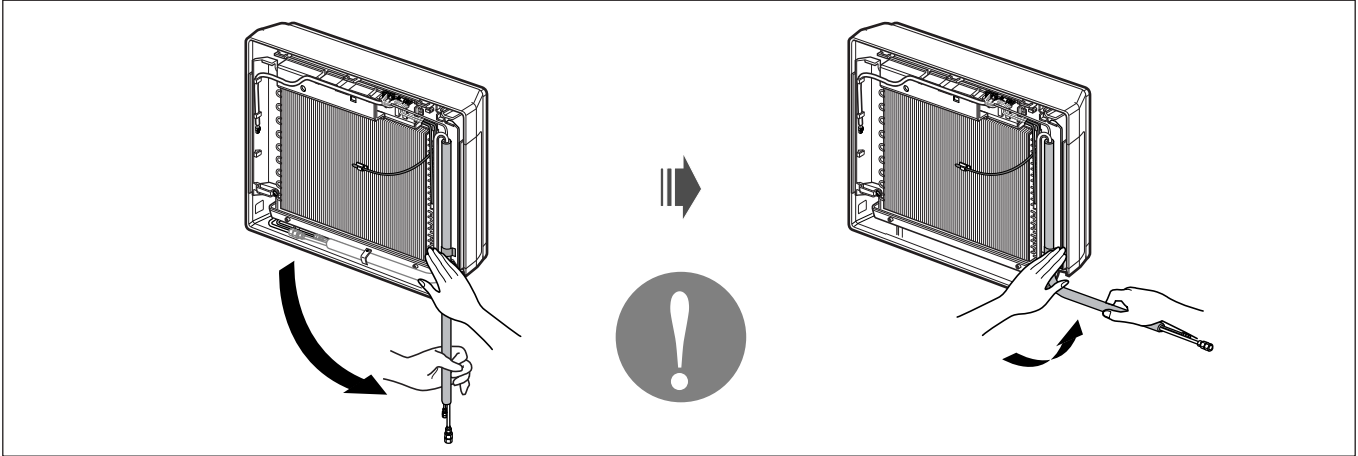

Bad case

- Following bending type from left to right may cause damage to the tubing.

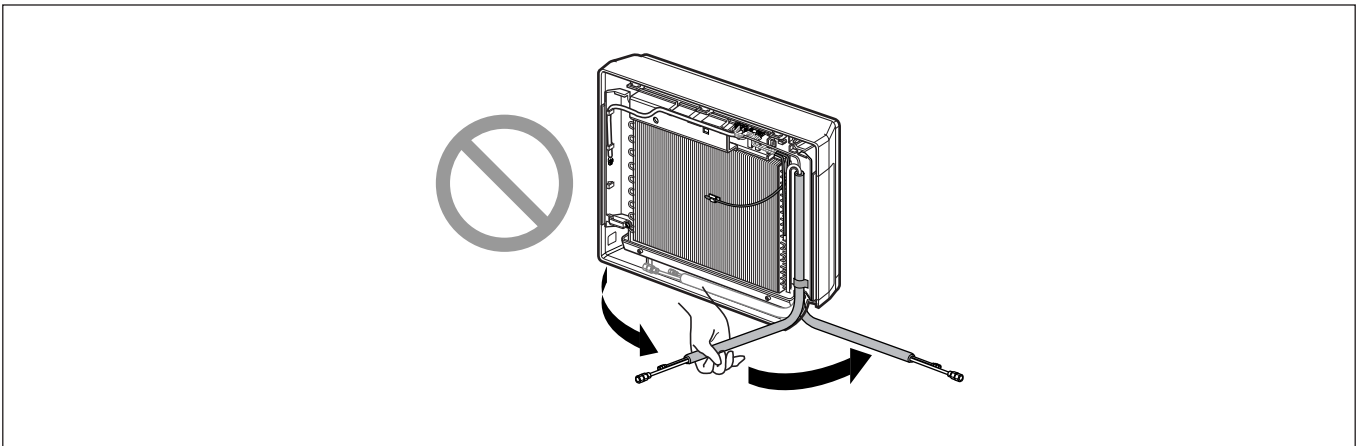

Connection of Piping -Outdoor

Put a couple drops of refrigerant oil on the face of the flare before assembling taking care not to add any contaminants.

Align the center of the pipings and sufficiently tighten the flare nut by hand.

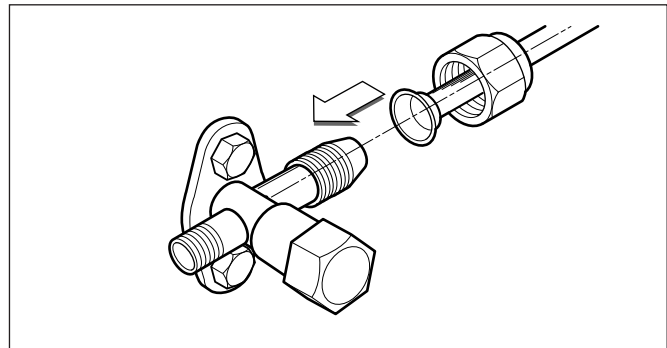

Finally, tighten the flare nut with torque wrench until the wrench clicks.

- When tightening the flare nut with torque wrench, ensure the direction for tightening follows the arrow on the wrench.

Outside diameter		Torque
mm	inch	kgf.cm
Ø6.35	1/4	180~250
Ø9.52	3/8	340~420
Ø12.7	1/2	550~660
Ø15.88	5/8	630~820
Ø19.05	3/4	980~1210

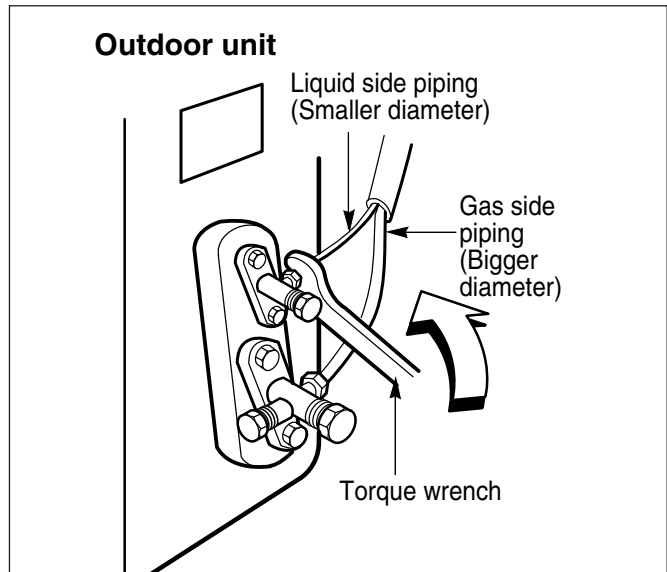

Connecting the cable between indoor unit and outdoor unit

Connecting the Cables

1. Remove the cover control from the unit by loosening the screw.
2. Dismount caps on the conduit panel.
3. Temporarily mount the conduit tubes on the conduit panel.
4. Properly connect both the power supply and low voltage lines to the corresponding terminals on the terminal block.
5. Ground the unit in accordance with local codes.
6. Be sure to size each wire allowing several inches longer than the required length for wiring.
7. Use lock nuts to secure the conduit tubes.

NOTICE

Connector trade size for this unit is 1/2"(12.7mm). Refer to "How to connect wiring to the terminals" for instructions on connecting depending on the wire type you are using.



WARNING:

- Be sure to comply with local codes while running the wire from the indoor unit to the outdoor unit(size of wire and wiring method, etc).
- Every wire must be connected firmly.
- No wire should be allowed to touch refrigerant tubing, the compressor or any moving parts.

Power Supply

Model	Power source	AWG(MIN)		Fuse or breaker Capacity
		Ⓐ	Ⓑ	
9k/12k	1Ø, 115V	14	18	20A

Wiring Diagram

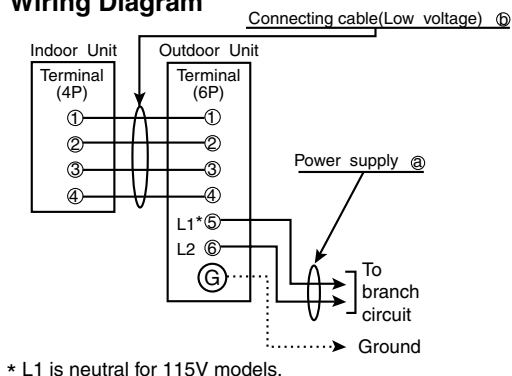

NOTICE

1. shows field wiring.
2. Separately wire the high and low voltage line.
3. Use heat-proof electrical wiring capable of withstanding temperatures up to 167°F(75°C).
4. Use outdoor and waterproof connection cable rated more than 300V for the connection between indoor and outdoor unit.
(For example, Type SJO-WA)

Outdoor unit

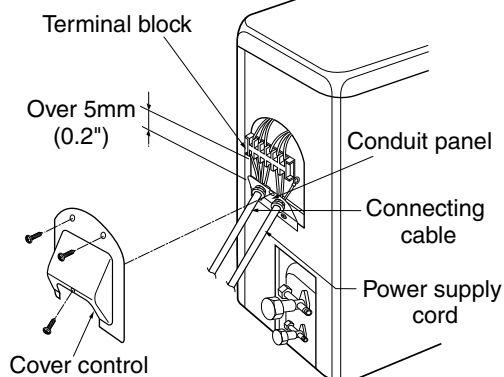

Connection method of the connecting cable(Example)

1. Dismount two-caps on the conduit panel.
2. Make a hole appropriate for the passage of connection cable through on cap by tool. (for low voltage line)
3. Pass the connecting cable through the hole.
4. Properly connect the cable on the terminal block.
5. Fix the connection cable with clamp cord provided on the unit not to have strain at the terminal when the connection cable is pulled outside up to a 35 pound weight.
6. Wind the vinyl tape round the connecting cable for sealing between the surface of the connection cable and cap.
7. Mount the taped part of cable on the cap.
8. Finally, mount the holed cap with the wound cable on the conduit panel.

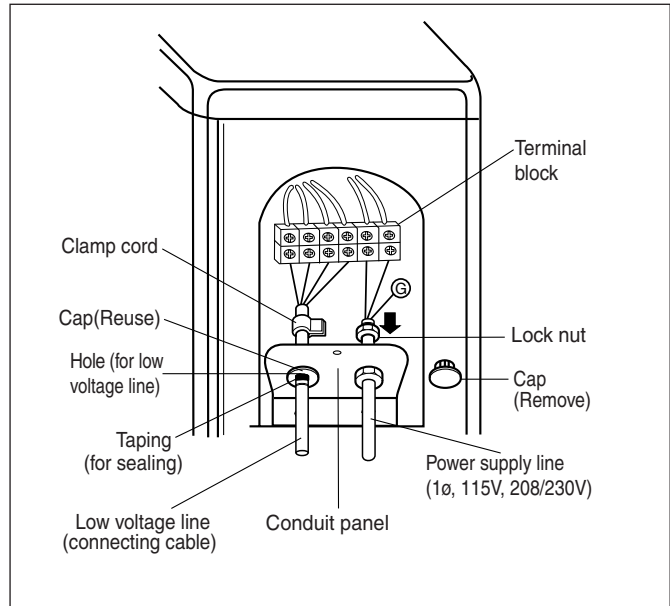

! WARNING:

Loose wiring may cause the terminal to overheat or result in unit malfunction. A fire hazard may also exist. Therefore, be sure all wiring is tightly connected.

When connecting each power wire to the corresponding terminal, follow instructions "How to connect wiring to the terminals" and fasten the wire tightly with the fixing screw of the terminal plate.

How to connect wiring to the terminals

- For solid core wiring (or F-cable)
 1. Cut the wire end with a wire cutter of wire-cutting pliers, then strip the insulation to expose the solid wire about 25mm(15/16")
 2. Using a screwdriver, remove the terminal screw(s) on the terminal plate.
 3. Using pliers, bend the solid wire to form a loop suitable for the terminal screw.
 4. Shape the loop wire properly, place it on the terminal plate and tighten securely with the terminal screw using a screwdriver.
- For strand wiring
 1. Cut the wire end with a wire cutter or wire-cutting pliers, then strip the insulation to expose the strand wiring about 10mm(3/8").
 2. Using a screwdriver, remove the terminal screw(s) on the terminal plate.
 3. Using a round terminal fastener or pliers, securely clamp each stripped wire end with a round terminal.
 4. Position the round terminal wire, and replace and tighten the terminal screw using a screwdriver.

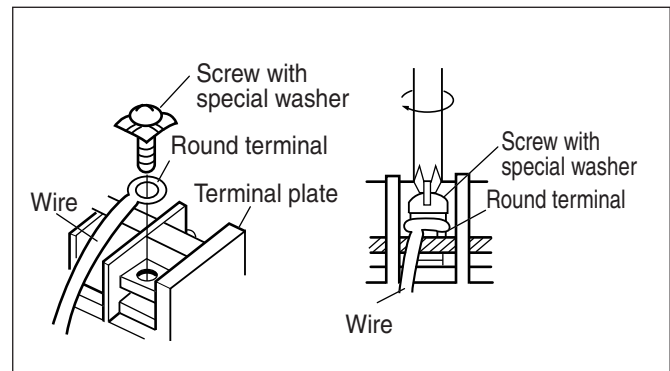
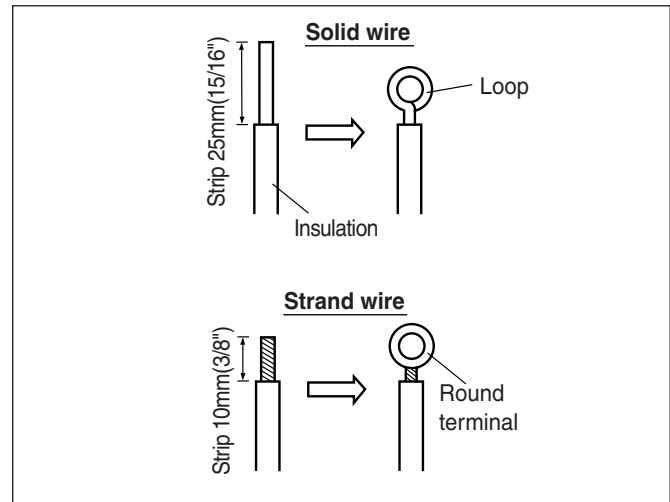

CAUTION

After the confirmation of the above conditions, prepare the wiring as follows:

- 1) **Never fail to have an individual power circuit specifically for the air conditioner. As for the method of wiring, be guided by the circuit diagram posted on the inside of control cover.**
- 2) **The screw which fasten the wiring in the casing of electrical fittings are liable to come loose from vibrations to which the unit is subjected during the course of transportation. Check them and make sure that they are all tightly fastened. (If they are loose, it could cause burn-out of the wires.)**
- 3) **Specification of power source.**
- 4) **Confirm that electrical capacity is sufficient.**
- 5) **Confirm that the starting voltage is maintained at more than 90 percent of the rated voltage marked on the name plate.**
- 6) **Confirm that the cable thickness is as specified in the power source specification. (Particularly note the relation between cable length and thickness.)**
- 7) **Always install an GFCI circuit breaker in a wet or moist area.**
- 8) **The following would be caused by voltage drop.**
 - Vibration of a magnetic switch, which will damage the contact point, open fuse, disturbance of the normal function of the overload.
- 9) **The means for disconnection from a power supply shall be incorporated in the fixed wiring and have an air gap contact separation of at least 3mm(0.12in) in each active(phase) conductors.**

Checking the drainage and forming the pipings

Checking the Drainage

To check the drainage.

1. Pour a glass of water on the evaporator.
2. Ensure the water flows through the drain hose of the indoor unit without any leakage and goes out the drain exit.

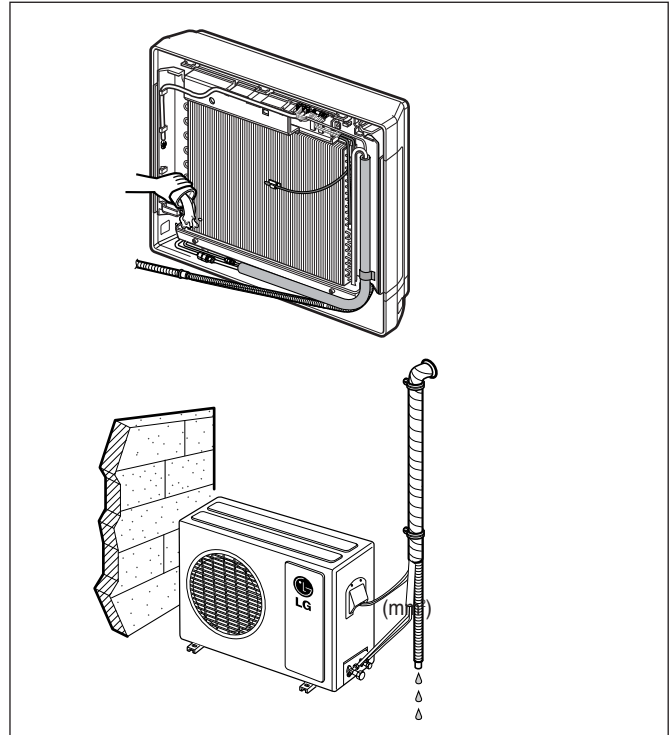

Drain piping

1. The drain hose should point downward for easy drain flow.

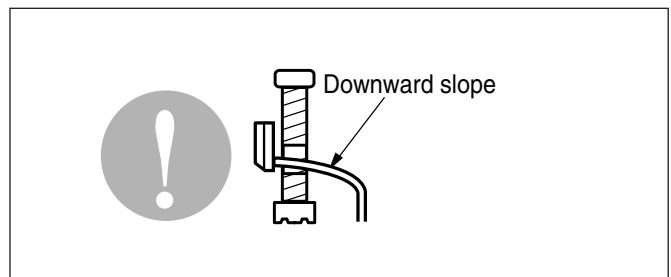

2. Do not make drain piping like the following.

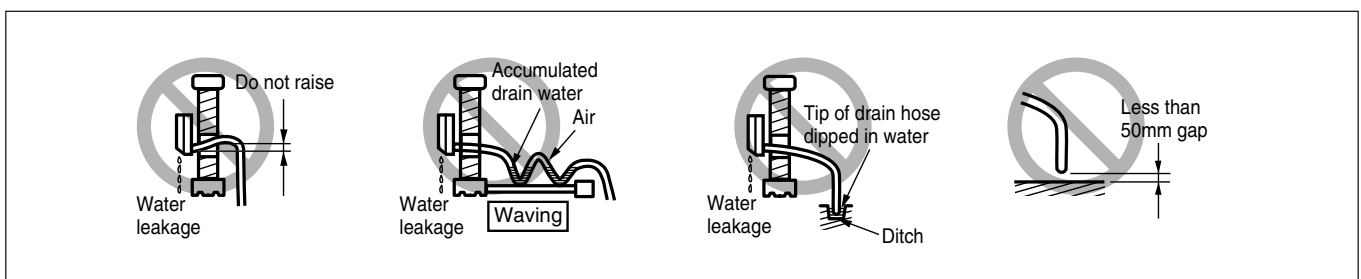

Forming the Piping

Form the piping by wrapping the connecting portion of the indoor unit with insulation material and secure it with two kinds of vinyl tapes.

- If you want to connect an additional drain hose, the end of the drain outlet should be routed above the ground. Secure the drain hose appropriately.

In cases where the outdoor unit is installed below the indoor unit perform the following.

1. Tape the piping, drain hose and connecting cable from down to up.
2. Secure the tapped piping along the exterior wall using saddle or equivalent.

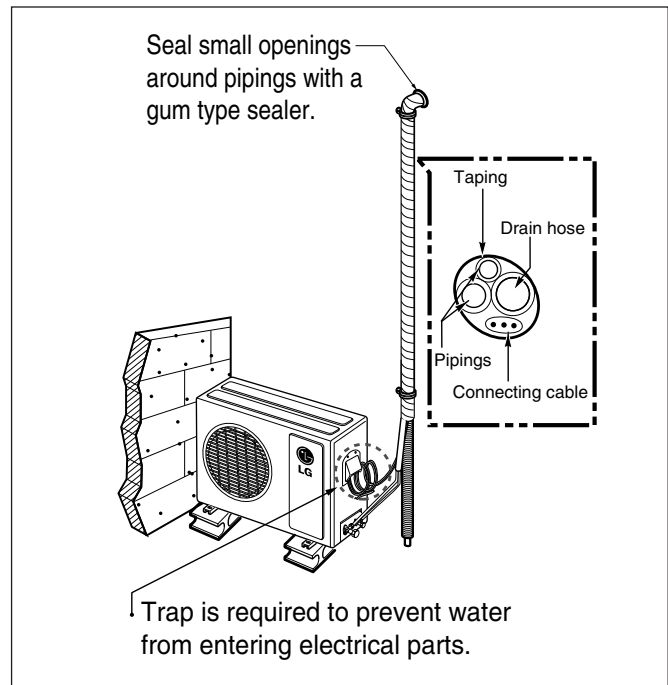

In cases where the outdoor unit is installed above the Indoor unit perform the following.

1. Tape the piping and connecting cable from down to up.
2. Secure the taped piping along the exterior wall. Form a trap to prevent water entering the room.
3. Fix the piping onto the wall by saddle or equivalent.

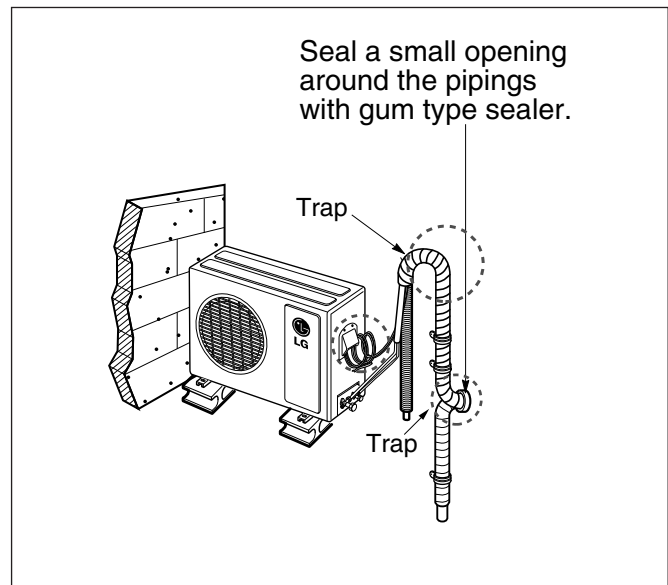

AIR PURGING

Air Purging

Air purging

The air and moisture remaining in the refrigerant system have undesirable effects as indicated below.

1. Pressure in the system rises.
2. Operating current rises.
3. Cooling(or heating) efficiency drops.
4. Moisture in the refrigerant circuit may freeze and block capillary tubing.
5. Water may lead to corrosion of parts in the refrigeration system.

Therefore, after evacuating the system, take a leak test for the piping and tubing between the indoor and outdoor unit.

Air purging with vacuum pump

1. Preparation

- Check that each tube(both liquid and gas side tubes) between the indoor and outdoor units have been properly connected and all wiring for the test run has been completed. Remove the service valve caps from both the gas and the liquid side on the outdoor unit. Note that both the liquid and the gas side service valves on the outdoor unit are kept closed at this stage.

2. Leak test

- Connect the manifold valve(with pressure gauges) and dry nitrogen gas cylinder to this service port with charge hoses.

CAUTION: Be sure to use a manifold valve for air purging. If it is not available, use a stop valve for this purpose. The "Hi" knob of the manifold valve must always be kept close.

- Pressurize the system to no more than 150 P.S.I.G. with dry nitrogen gas and close the cylinder valve when the gauge reading reached 150 P.S.I.G. Next, test for leaks with liquid soap.

CAUTION: To avoid nitrogen entering the refrigerant system in a liquid state, the top of the cylinder must be higher than its bottom when you pressurize the system. Usually, the cylinder is used in a vertical standing position.

1. Do a leak test of all joints of the tubing(both indoor and outdoor) and both gas and liquid side service valves.

Bubbles indicate a leak. Be sure to wipe off the soap with a clean cloth.

2. After the system is found to be free of leaks, relieve the nitrogen pressure by loosening the charge hose connector at the nitrogen cylinder. When the system pressure is reduced to normal, disconnect the hose from the cylinder.

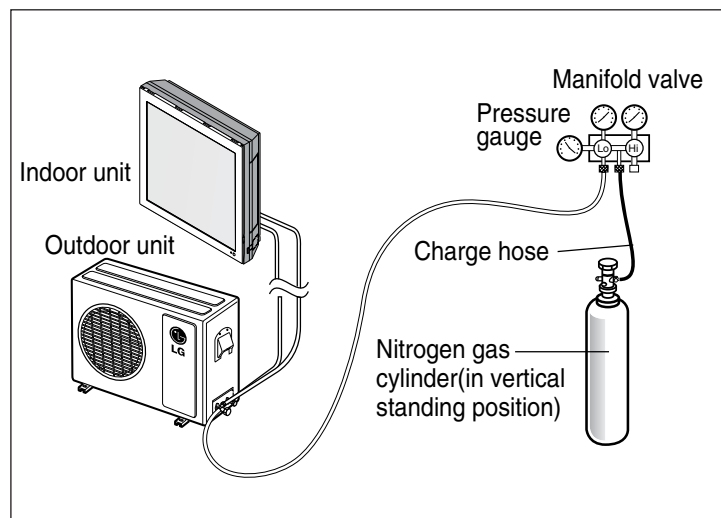

Soap water method

1. Remove the caps from the 2-way and 3-way valves.
2. Remove the service-port cap from the 3-way valve.
3. To open the 2-way valve turn the valve stem counterclockwise approximately 90°, wait for about 2~3 sec, and close it.
4. Apply a soap water or a liquid neutral detergent on the indoor unit connection or outdoor unit connections by a soft brush to check for leakage of the connecting points of the piping.
5. If bubbles come out, the pipes have leakage

Evacuation

1. Connect the charge hose end described in the preceding steps to the vacuum pump to evacuate the tubing and indoor unit.

Confirm the "Lo" knob of the manifold valve is open.
Then, run the vacuum pump.

The operation time for evacuation varies with tubing length and capacity of the pump. The following table shows the time required for evacuation.

Required time for evacuation when 30 gal/h vacuum pump is used	
If tubing length is less than 10m (33 ft)	If tubing length is longer than 10m (33 ft)
10 min. or more	15 min. or more

2. When the desired vacuum is reached, close the "Lo" knob of the manifold valve and stop the vacuum pump.

Finishing the job

1. With a service valve wrench, turn the valve stem of liquid side valve counter-clockwise to fully open the valve.
2. Turn the valve stem of gas side valve counter-clockwise to fully open the valve.
3. Loosen the charge hose connected to the gas side service port slightly to release the pressure, then remove the hose.
4. Replace the flare nut and its bonnet on the gas side service port and fasten the flare nut securely with an adjustable wrench. This process is very important to prevent leakage from the system.
5. Replace the valve caps at both gas and liquid side service valves and fasten them tight.

This completes air purging with a vacuum pump.
The air conditioner is now ready to test run.

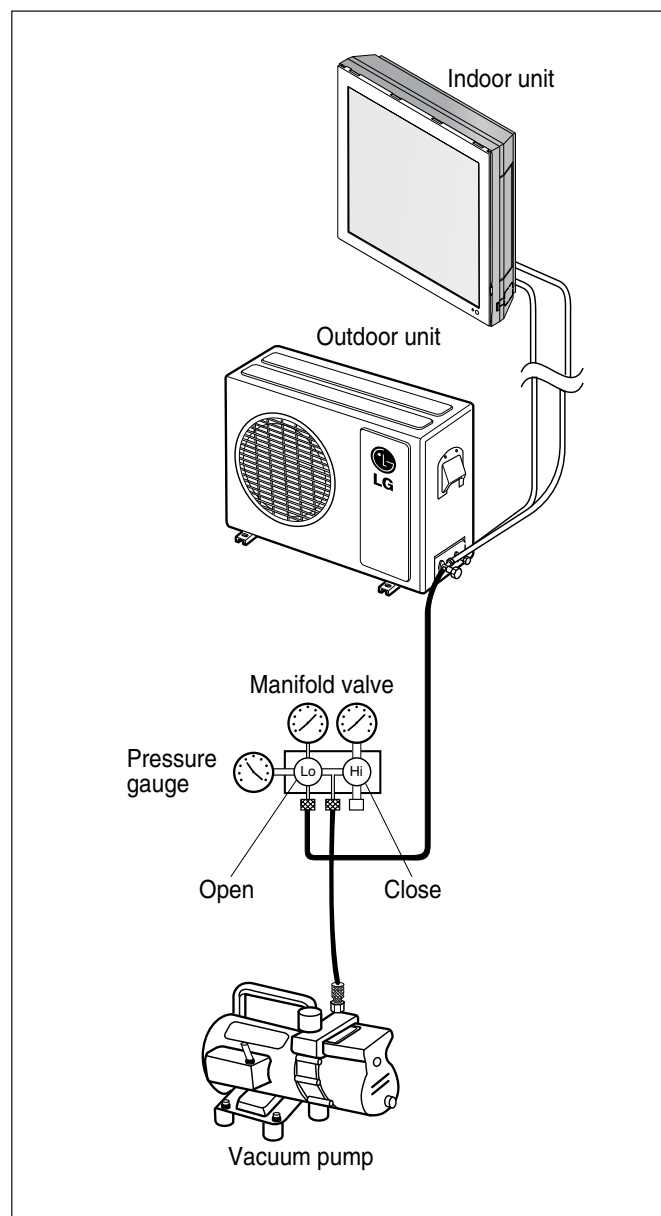
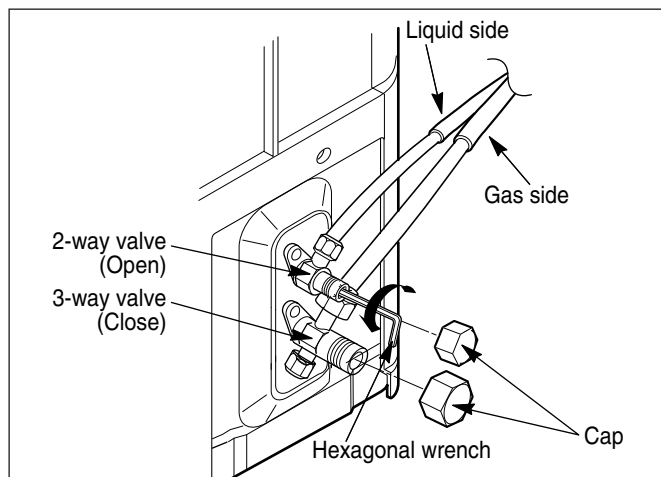

Charging

- Each outdoor unit is factory charged (nameplate charge) for the evaporator as well as a 7.5m(25ft) line set. Any time a line set is used either shorter or longer then the nominal 7.5m(25ft) line set length the refrigerant charge has to be adjusted.
- Whether the line set is made shorter or longer you must adjust the charge based on how many ft of tubing are either added or removed based on 20g(0.22oz) of R-410A per meter(foot).

Capacity (Btu/h)	Pipe Size		Standard Length m(ft)	Max. Elevation Ⓢ m(ft)	Max. length Ⓐ m(ft)	Additional Refrigerant g/m(oz/ft)
	Suction	Evap				
9k, 12k	Ø12.7mm(1/2")	Ø6.35mm(1/4")	7.5(25)	7.5(25)	15(49)	20(0.22)

Example: A 30ft line set is used
 5 additional ft X 0.22 ounce per foot= add 1.1 ounces of R-410A

Important:

If you are ever uncertain of the unit charge, reclaim, evacuate and weigh in the correct charge using the unit nameplate charge adjusting for line sets longer or shorter than 7.5m(25ft).

⚠ CAUTION

Confirm the refrigerant R-410A. Use manifold gauge and hose for R-410A.

Panel Front Assembly

1. First, Check the side cover assembly exactly, and fix the power cord in the bottom groove of cover side left.

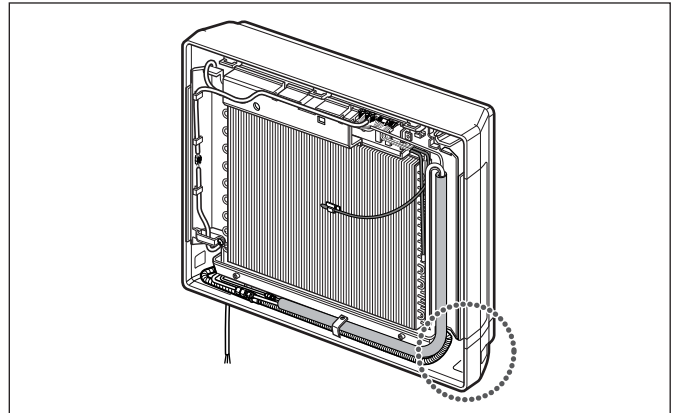

2. Assemble connecting lead wire with controller, fix the upper part of panel front, and match the lower part of panel front.

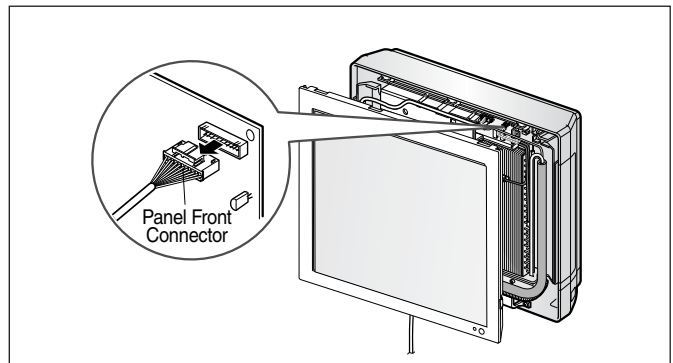

3. Screw up panel front, and suspend the hook of panel front in the groove.

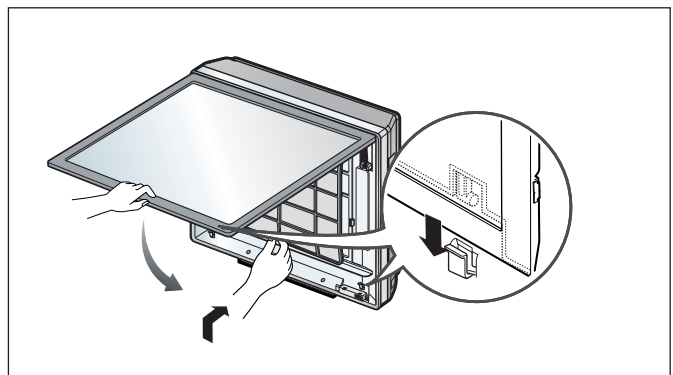
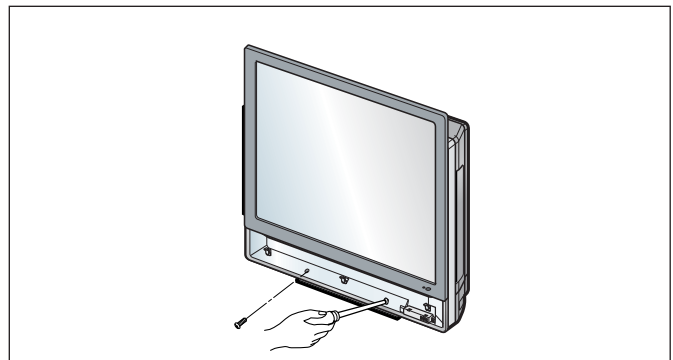

TEST RUNNING

Test Running

1. Check that all tubing and wiring are properly connected.
2. Check that the gas and liquid side service valves are fully open.

Prepare remote controller

1. Remove the battery cover by pulling it according to the arrow direction.
2. Insert new batteries making sure that the (+) and (-) of battery are installed correctly.
3. Reattach the cover by pushing it back into position.

NOTICE

- Use 2 AAA(1.5volt) batteries. Do not use rechargeable batteries.
- Remove the batteries from the remote controller if the system is not used for a long time.

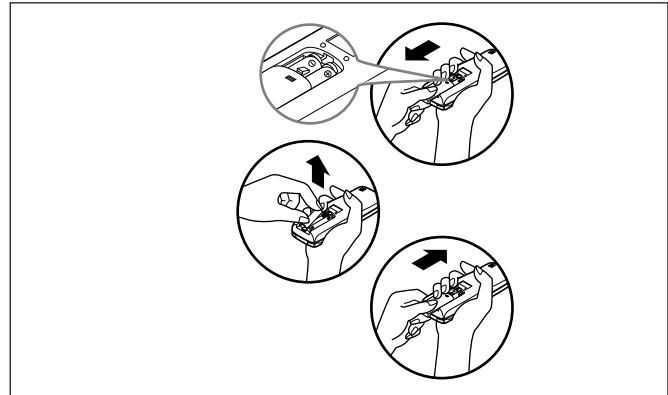

Settlement of outdoor unit

1. Anchor the outdoor unit with a bolt and nut($\phi 0.39''(\phi 10\text{mm})$) tightly and horizontally on a concrete or rigid mount.
2. When installing on the wall, roof or rooftop, anchor the mounting base securely with a nail or wire assuming the influence of wind and earthquake.
3. If the vibration of the unit is transmitted to the hose, secure the unit with an anti-vibration rubber.

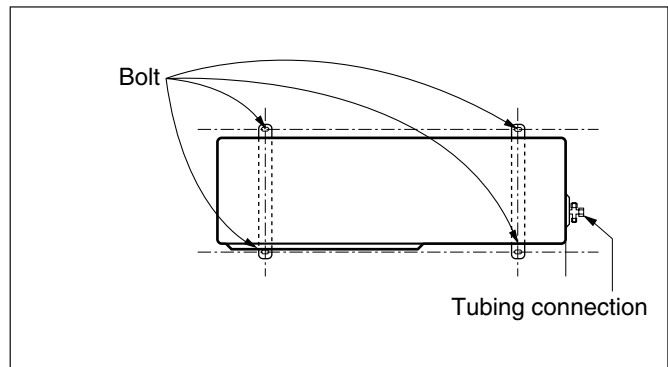

Evaluation of the performance

Operate the unit for 15~20 minutes, then check the system refrigerant charge:

1. Measure the pressure of the gas side service valve.
2. Measure the temperature of the intake and discharge of air.
3. Ensure the difference between the intake temperature and the discharge is more than 46.4°F(8°C)
4. For reference; the gas side pressure of optimum condition is as below.(Cooling)

The air conditioner is now ready for use.

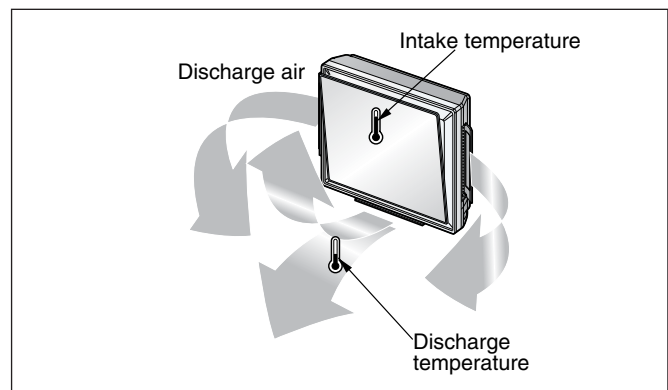

Refrigerant	Outside ambient TEMP.	The pressure of the gas side service valve.
R-410A	95°F(35°C)	8.5~9.5kg/cm ² G(120~135 P.S.I.G.)

NOTICE If the actual pressure is higher than shown, the system is most likely over-charged, and charge should be removed. If the actual pressure are lower than shown, the system is most likely undercharged, and charge should be added.

PUMP DOWN

This is performed when the unit is relocated or the refrigerant circuit is serviced.

Pump Down means collecting all refrigerant into the outdoor unit without the loss of refrigerant.



CAUTION: Be sure to perform Pump Down procedure in the cooling mode.

Pump Down Procedure

1. Connect a low-pressure gauge manifold hose to the charge port on the gas side service valve.
2. Open the gas side service valve halfway and purge the air in the manifold hose using the refrigerant.
3. Close the liquid side service valve(all the way).
4. Turn on the unit's operating switch and start the cooling operation.
5. When the low-pressure gauge reading becomes 1 to 0.5kg/cm² G(14.2 to 7.1 P.S.I.G.), fully close the gas side valve and then quickly turn off the unit. Now Pump Down procedure is completed, and all refrigerant is collected into the outdoor unit.

How to replace picture & photograph

1. Turn off power and then open the upper part of front panel.

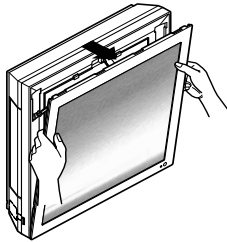

2. Pull out the both links of lower part of front panel, as described in the below picture.

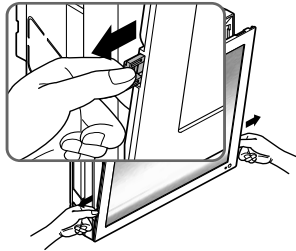

3. Push and close the top part of the front panel and then pull the bottom part of the panel forward until it is secured.

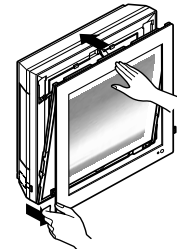

4. Take out picture.

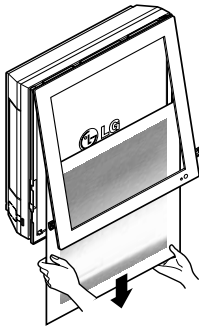

5. Turn upside-down of the picture and turn over mat, then take off a protective tape attached at the mat.

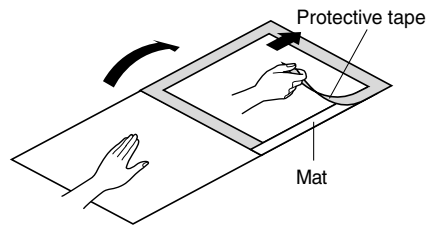

6. Place the picture/photograph between the exited picture and mat. (Recommended size of a photo/picture: 450mm x 450mm)

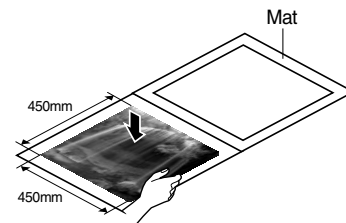

7. Cover mat and press down with hand(s) until contacting closely.

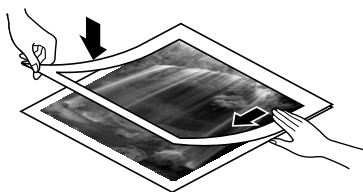

8. Slide the photo graph/drawing requested under both hanger parts as following, and fix them. Press the front panel lightly to close.

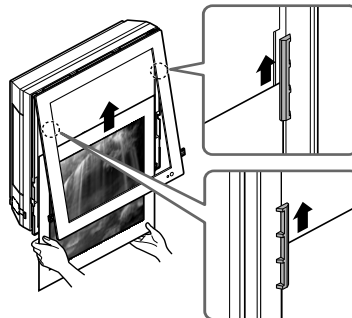

9. Push both links of lower part of panel inside and fix it. Then turn on.

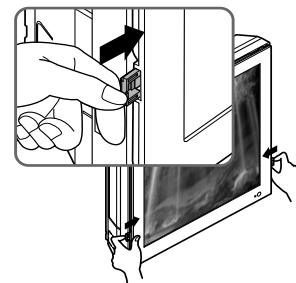

※ In case a mat is not used, recommended size of a photo/picture: 522mm x 522mm

When powering on after replacing filter and picture, the front panel doesn't intervene.

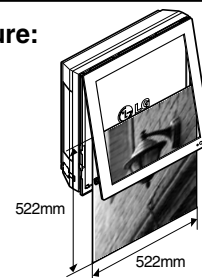

Operation

Functions

Indoor Unit

Operation ON/OFF by Remote controller

Sensing the Room Temperature

- Room temperature sensor (THERMISTOR)

Room temperature control

- Maintains the room temperature in accordance with the Setting Temp.

Starting Current Control

- Indoor fan is delayed for 5 seconds at the starting.

Time Delay Safety Control

- Restarting is inhibited for approx. 3 minutes.

Indoor Fan Speed Control

- High, Med, Low and Auto

Operation indication Lamps (LED)

- --- Lights up in operation

Healthy Dehumidification Mode

- Intermittent operation of fan at low speed

Sleep Mode Auto Control

- The fan is switched to low(Cooling), med(Heating) speed.
- The unit will be stopped after 1, 2, 3, 4, 5, 6, 7 hours.

Auto Air Control by the unit electronic control

- The fan is switched to intermittent or irregular operation.
- The fan speed is automatically switched from high to low speed.

Chaos Swing

- The louver can be set at the desired position or swing up and down automatically.

Defrost control(Heating)

- Both the indoor and outdoor fan stops during defrosting.
- Hot start will be operated after defrosting ends.

Hot-start Control (Heating)

- The indoor fan stops until the indoor pipe temperature will be reached at 82°F(28°C).

The function of main control

1. Time delay Safety Control

- 3min.; The compressor operation is delayed for 3 minutes to balance the pressure of cycle.
(Protection of compressor)
- 5sec.; The indoor fan is delayed for 5 seconds, when operating initially, to prevent noises occurred by the vertical louver and wind.
- 2min.; The reversing valve is delayed for 2 minutes to prevent the refrigerant-gas for abnormal noise when the heating operation is OFF or switched to the other operation mode while compressor is off.
While compressor is running, it takes 3~5 seconds to switch.

2. Chaos Swing Mode

- By the Chaos Swing key input, the vane automatically operates with the Chaos Swing or they are fixed to the desired direction.
- While in Chaos Swing mode, the angles of cooling and heating cycle operations are different.

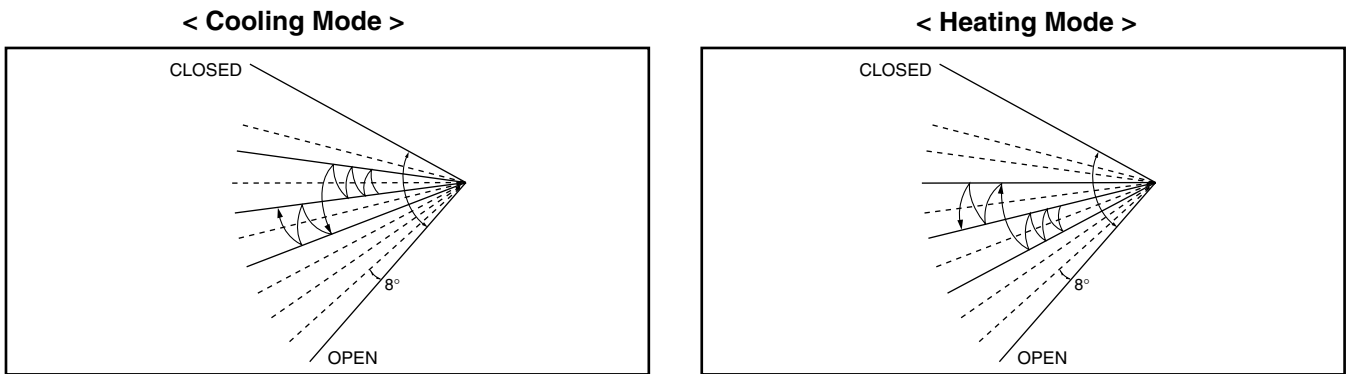

3. Cooling Operation Mode

- When selecting the Cooling(※) Mode Operation, the unit will operate according to the setting by the remote control and the operation diagram is shown below.

INTAKE AIR TEMP.					
SETTING TEMP. +1°F (Compressor ON)					
SETTING TEMP. -1°F (Compressor OFF)	← More than 3 minutes →		← More than 3 minutes →		
INDOOR FAN SPEED	Setting fan speed	Low	Setting fan speed	Low	Setting fan speed
COMPRESSOR	ON	OFF	ON	OFF	ON

■ Protection of the indoor heat exchanger from frosting

- Compressor and outdoor fan stop when indoor pipe temperature is below 32°F(0°C) and restart at the pipe temperature is above 45°F(7°C).

. Auto Operation (Electronic control mode)

• The operation procedure is shown below. (Cooling & Heating Model)

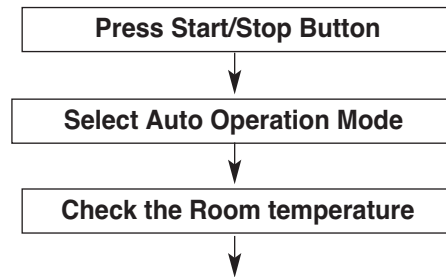

Operation mode Indoor fan speed Setting temperature				are decided automatically by the unit electronic control.
Intake-air temperature	below 70°F	Over 70°F ~ below 76°F	Over 76°F	
Operation Mode	Heating	Soft Dry	Cooling	

* If initial mode is decided, that mode is continued without the room temperature changing.

■ Auto Operation for Cooling

Operation Condition	Intake-air Temperature	Setting Temperature	Fan Speed	Air Direction Control
When Auto Operation initial start	Over 78°F	77°F	Controlled by the electronic control	In this mode, when pressing the vertical air direction control button, vertical louver swings up and down automatically.
	Over 76°F~below 78°F	Intake air -1°C		
	Over 72°F~below 76°F	Intake air -0.5°C		
	Over 68°F~below 72°F	Intake air temperature		
	below 64°F	64°F		
When pressing room temperature setting button during Auto Operation	Over 64°F~below 86°F	Electronic control		
	below 64°F	64°F		
	over 86°F	86°F		

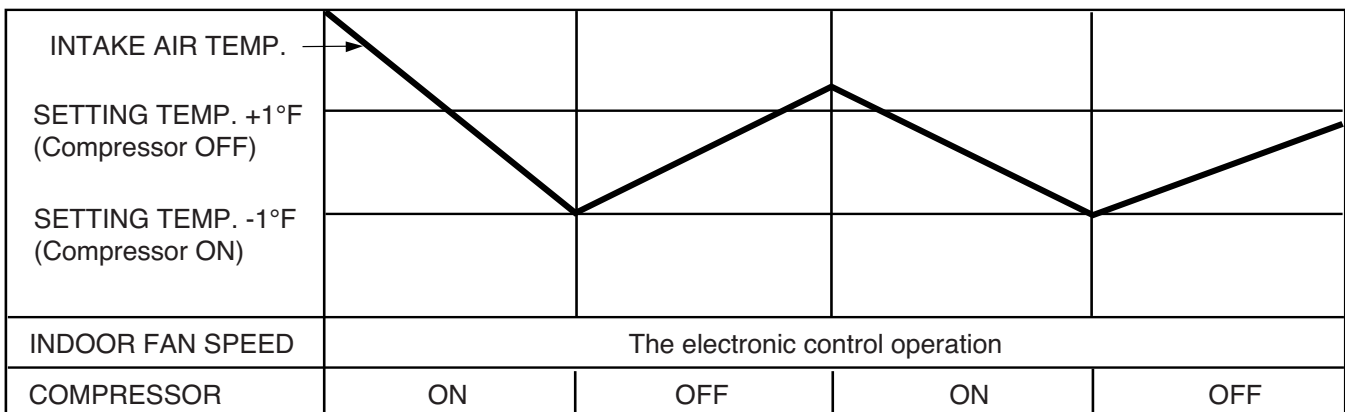

■ **Auto Operation for Dehumidification(only Heating Model)**

- The Setting temperature will be same that of the auto operation for cooling.
- Compressor ON temperature; Setting temperature +2°F
- Compressor OFF temperature; Setting temperature -1°F

Intake-air temp.	below 68°F	Over 68°F~below 70°F	over 86°F
Setting temp.	68°F	Intake air temperature +1°F	86°F

■ **Auto Operation for Heating(only Heating Model)**

- Compressor ON temperature; Setting temperature
- Compressor OFF temperature; Setting temperature +6°F

■ **Vertical louver auto operation** : During Auto Operation, pressing the chaos swing button makes the horizontal louvers swing up and down automatically.
If you want to stop auto-swing, press chaos swing button again.

5. Healthy Dehumidification

- When the dehumidification operation input by the remote control is received, the intake air temperature is detected and the setting temp is automatically set according to the intake air temperature.
 - 79°F ≤ Intake Air Temp ⇨ 77°F
 - 75°F ≤ Intake Intake Air Temp < 79°F ⇨ Intake Air Temp - 2°F
 - 64°F ≤ Intake Intake Air Temp < 75°F ⇨ Intake Air Temp - 1°F
 - Intake Air Temp < 64°F ⇨ 64°F
- While in compressor off, the indoor fan repeats low airflow speed and pause.
- While the intake air temp is between compressor on temp. and compressor off temp., 10-min dehumidification operation and 4-min compressor off repeat.
 - Compressor ON Temp. ⇨ Setting Temp + 1°F
 - Compressor OFF Temp. ⇨ Setting Temp - 1°F
- In 10-min dehumidification operation, the indoor fan operates with the low airflow speed.

6. Heating Operation Mode(only Heating Model)

The unit will operate according to the setting conditions by the remote controller.
The operation diagram is shown below.

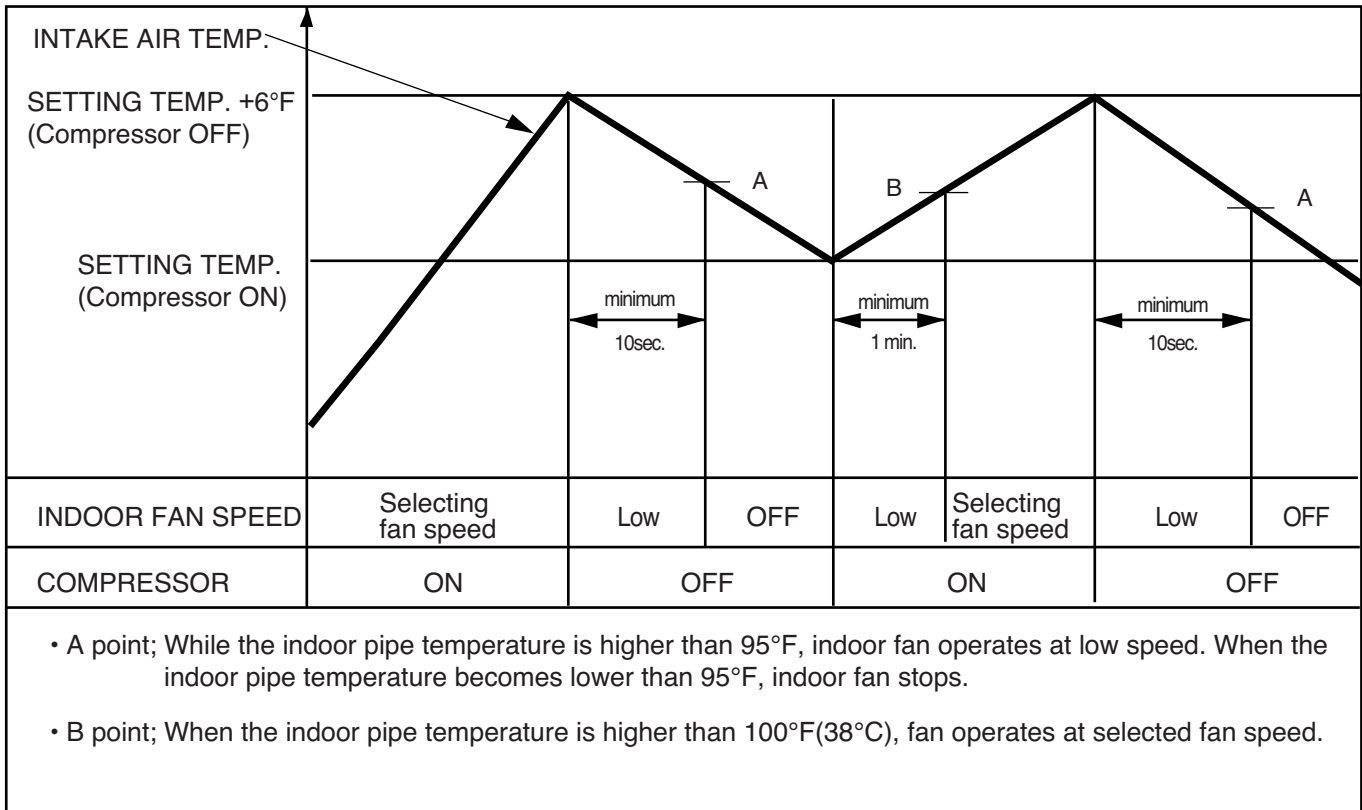

■ Hot-Start Control

- The indoor fan stops until the indoor pipe temperature will be reached at 82°F.
- During heating operation, if indoor pipe temperature falls below 78°F fan stops.
- The operation diagram is shown below.

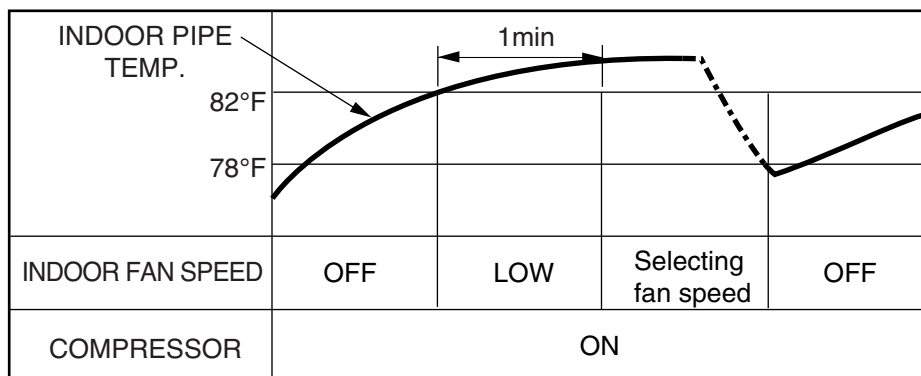

7. Cooling or Heating Mode with Sleep Mode Auto Control

- When selecting the Cooling (☼) or the Heating (☀) combined with the Sleep Mode Auto Control(☆), the operation diagram is as following.

■ Cooling Mode with the Sleep Mode

- The setting temperature will be automatically raised by 2°F 30 minutes later and by 4°F 1 hour later.
- The operation will be stopped after 1, 2, 3, 4, 5, 6, 7 hours.

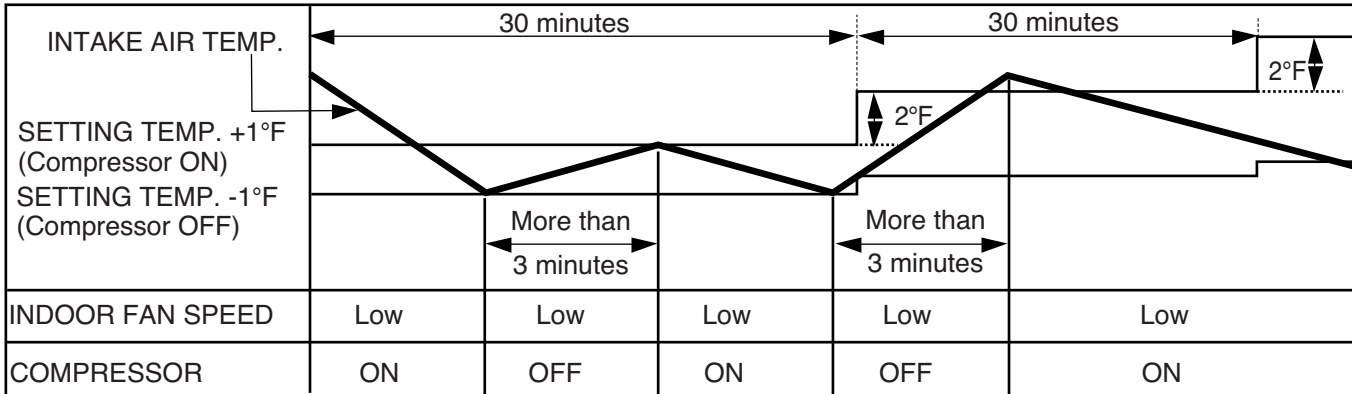

■ Heating Mode with the Sleep Mode(only Heating Model)

- The operation will be stopped after 1, 2, 3, 4, 5, 6, 7 hours.

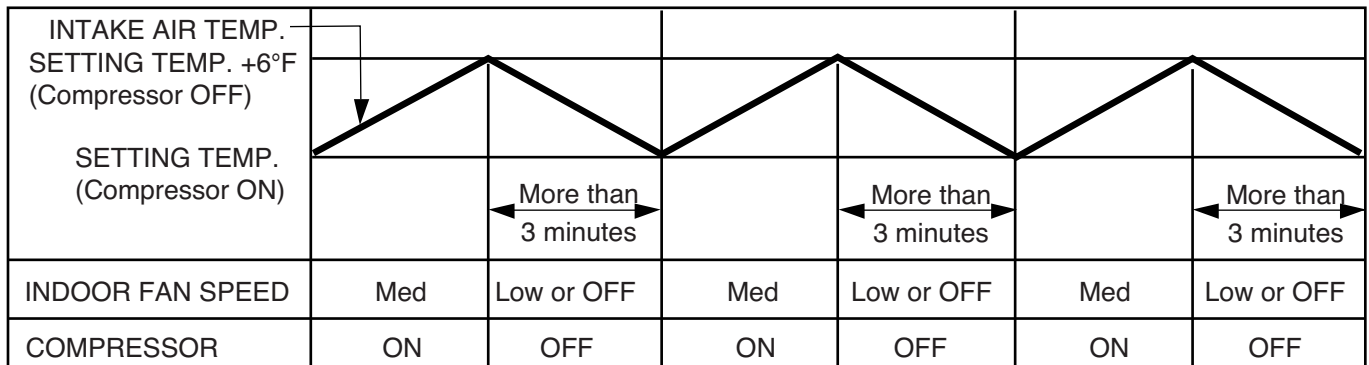

8. Forced Operation

Operation procedures when the remote control can't be used.

The operation will be started if the power button is pressed.

If you want to stop operation, re-press the button.

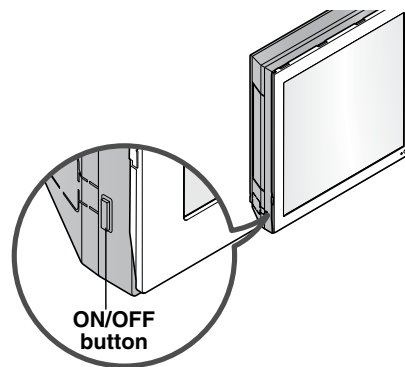

	Cooling Model	Heat pump Model		
		Room Temp. $\geq 76^{\circ}\text{F}(24^{\circ}\text{C})$	$70^{\circ}\text{F}(21^{\circ}\text{C}) \leq \text{Room Temp.} < 76^{\circ}\text{F}(24^{\circ}\text{C})$	Room Temp. $< 70^{\circ}\text{F}(21^{\circ}\text{C})$
Operating mode	Cooling	Cooling	Healthy Dehumidification	Heating
Indoor FAN Speed	High	High	Healthy Dehumidification Rule	High
Setting Temperature	$72^{\circ}\text{F}(22^{\circ}\text{C})$	$72^{\circ}\text{F}(22^{\circ}\text{C})$	$74^{\circ}\text{F}(23^{\circ}\text{C})$	$76^{\circ}\text{F}(24^{\circ}\text{C})$

Test operation

During the TEST OPERATION, the unit operates in cooling mode at high speed fan, regardless of room temperature and resets in 18 minutes.

During test operation, if remote controller signal is received, the unit operates as remote controller sets.

If you want to use this operation, Press and hold the ON/OFF button for 3~5 seconds, then the buzzer sound 1 "beep".

If you want to stop the operation, re-press the button.

9. Auto restart

In case the power comes on again after a power failure, Auto Restarting Operation is the function to operate procedures automatically to the previous operating conditions.

So there is no need of activating this function by pressing any key or button.

In the initial mode, the fan operates at a low speed and the compressor starts 2.5~3 minutes later.

As the compressor starts, the fan speed also resumes its previous setting mode.

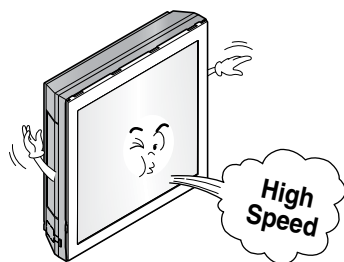

Helpful information

Fan speed and cooling capacity.

The cooling capacity indicated in the specification is the value when the fan speed is set to high, and the capacity will be lower at low or medium fan speed.

High fan speed is recommended when you wish to cool the room quickly.

NOTICE

Auto restart function has set enable as factory default.

But customer can set up by following this instruction.

To be disable function

- Press and hold the ON/OFF button for 6 seconds, then the buzzer sound 2 "beep" and the indicator lamp (1) blinks 4 times.

To be enable function

- Press and hold the ON/OFF button for 6 seconds, then the buzzer sound 2 "beep" and the indicator lamp (1) brights 4 times.

Display Function

Signal Receptor

Receives the signals from the remote control.(Signal receiving sound: two short beeps or one long beep.)

Operation Indication Lamps

- ① **On/Off** : Lights up during the system operation.

Self-diagnosis Function

Error Code	Error LED (Indoor body operation LED)	Error contents	SVC check point
1	<p>(once)</p> <p>3sec 3sec 3sec</p>	<ul style="list-style-type: none"> Indoor room temperature thermistor open/short Indoor pipe temperature thermistor open/short. 	<ul style="list-style-type: none"> Indoor TH assy check
2	<p>(twice)</p> <p>3sec 3sec</p>	<ul style="list-style-type: none"> Outdoor pipe temperature thermistor open/short. 	<ul style="list-style-type: none"> Outdoor TH assy check
5	<p>(5times)</p> <p>3sec</p>	<ul style="list-style-type: none"> Poor communication. 	<ul style="list-style-type: none"> Communication line/circuit check

Remote Control Operations

The controls will look like the following.

Controls

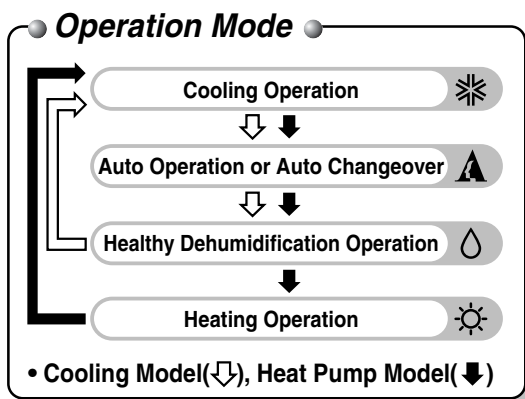
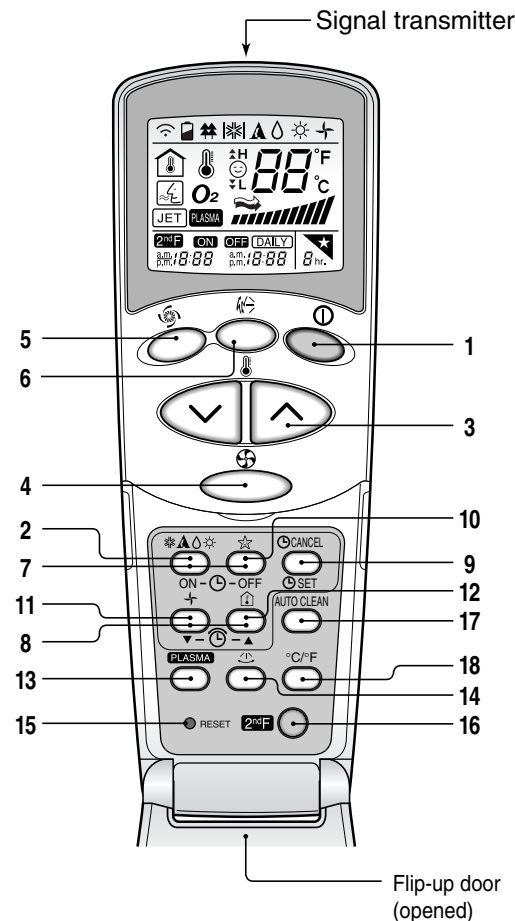

- 1. START/STOP BUTTON**
 Operation starts when this button is pressed and stops when the button is pressed again.
- 2. OPERATION MODE SELECTION BUTTON**
 Used to select the operation mode.
- 3. ROOM TEMPERATURE SETTING BUTTONS**
 Used to select the room temperature.
- 4. INDOOR FAN SPEED SELECTOR**
 Used to select fan speed in four steps low, medium, high and CHAOS.
- 5. JET COOL/HEATING(OPTIONAL)**
 Used to start or stop the speed cooling/heating. (speed cooling/heating operates super high fan speed in cooling/heating mode.)
- 6. CHAOS SWING BUTTON**
 Used to stop or start louver movement and set the desired up/down airflow direction.
- 7. ON/OFF TIMER BUTTONS**
 Used to set the time of starting and stopping operation.
- 8. TIME SETTING BUTTONS**
 Used to adjust the time.
- 9. TIMER SET/CANCEL BUTTON**
 Used to set the timer when the desired time is obtained and to cancel the Timer operation.
- 10. SLEEP MODE AUTO BUTTON**
 Used to set Sleep Mode Auto operation.
- 11. AIR CIRCULATION BUTTON**
 Used to circulate the room air without cooling or heating.
- 12. ROOM TEMPERATURE CHECKING BUTTON**
 Used to check the room temperature.
- 13. NEO PLASMA(OPTIONAL)**
 Used to start or stop the plasma-purification function.
- 14. HORIZONTAL AIRFLOW DIRECTION CONTROL BUTTON (OPTIONAL)**
 Used to set the desired vertical airflow direction.
- 15. RESET BUTTON**
 Used prior to resetting time.
- 16. 2nd F Button**
 Used prior to using modes printed in blue at the bottom of buttons.
- 17. AUTO CLEAN (OPTIONAL)**
 Used to set Auto Clean mode.
- 18. °C/°F SWITCH BUTTON**
 Used to switch temperature reading from Centigrade to Fahrenheit.

Disassembly

Indoor Unit

! WARNING: Disconnect the unit from power supply before making any checks. Be sure the power switch is set to "OFF"

1. To remove the Grille from the Chassis.

- Pull the grille bottom, then remove 2 securing screws.
- Lift the both lower parts of panel front.
- After pull down this panel a bit, separate connecting wire with product.

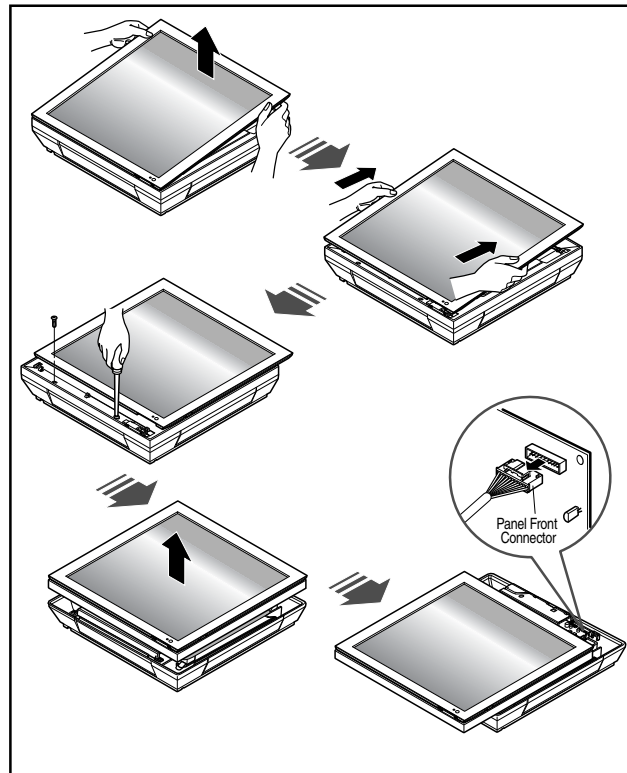

2. To remove the Control Box.

- Before removing the control box, be sure to disconnect the wires from PWB.
- Pull the cover control out from the control box and disconnect other wires.
- Remove securing screws.
- Pull the control box out from the chassis carefully.

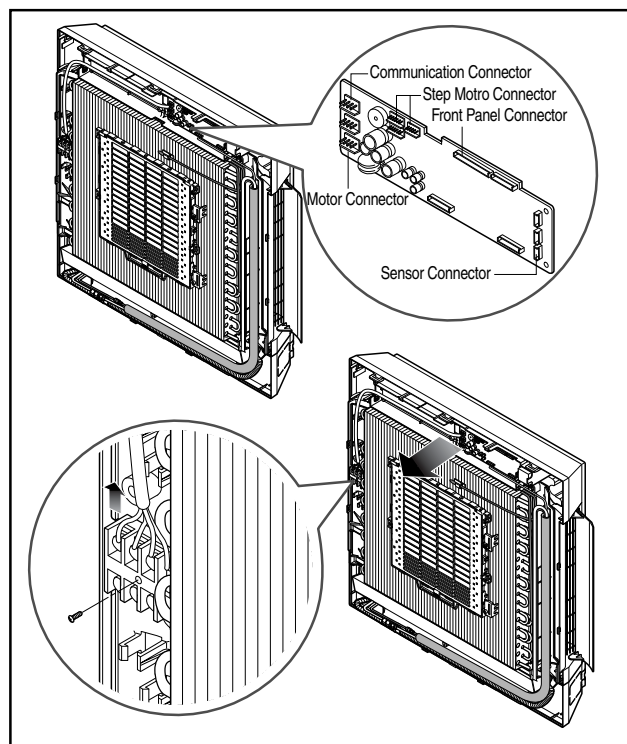

3. To remove the Evaporator.

- Remove hole tubing holde.
- Remove 2 screws securing the evaporator.
- Pull the evaporator out from the chassis carefully.

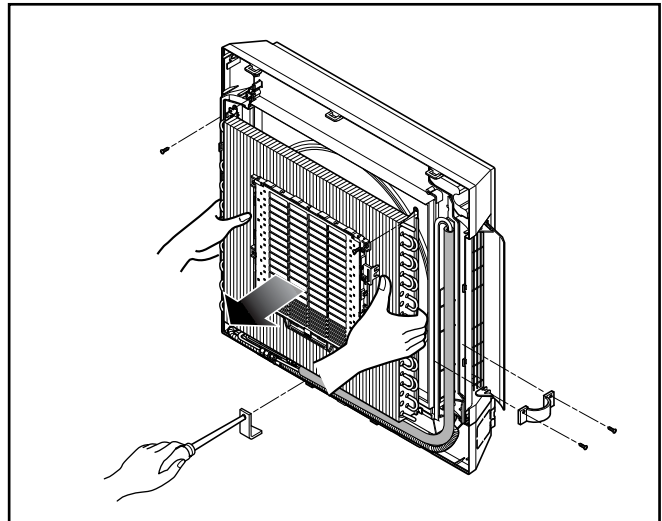
**4. Before removing the Turbo Fan.**

- Remove the securing screws from the chassis.
- Pull the pipe, top cover and the air guide.

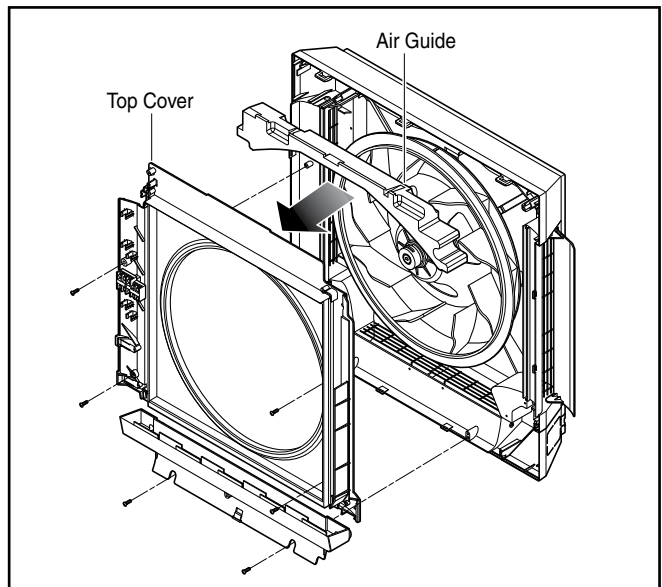
**5. To remove the Motor.**

- Remove the securing bolt from the motor shaft.
- Pull the fan out from the motor shaft.
- Remove 4 screws securing motor mount from the chassis and lift up the motor mount and the bracket.

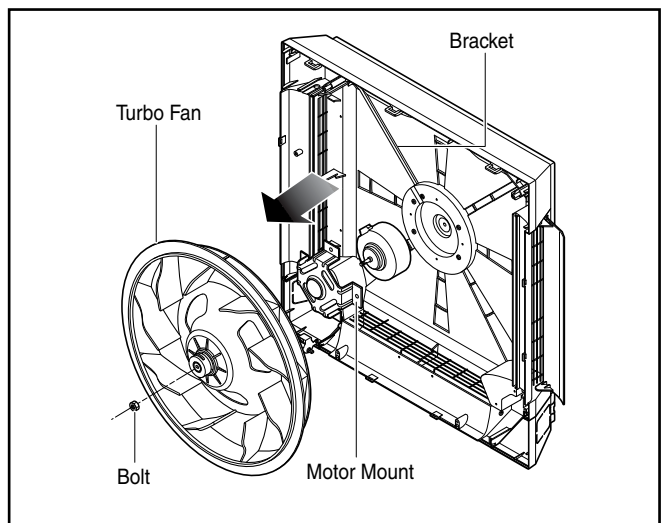

Schematic Diagram

Heat Pump/Cooling Only Series(Indoor Unit)

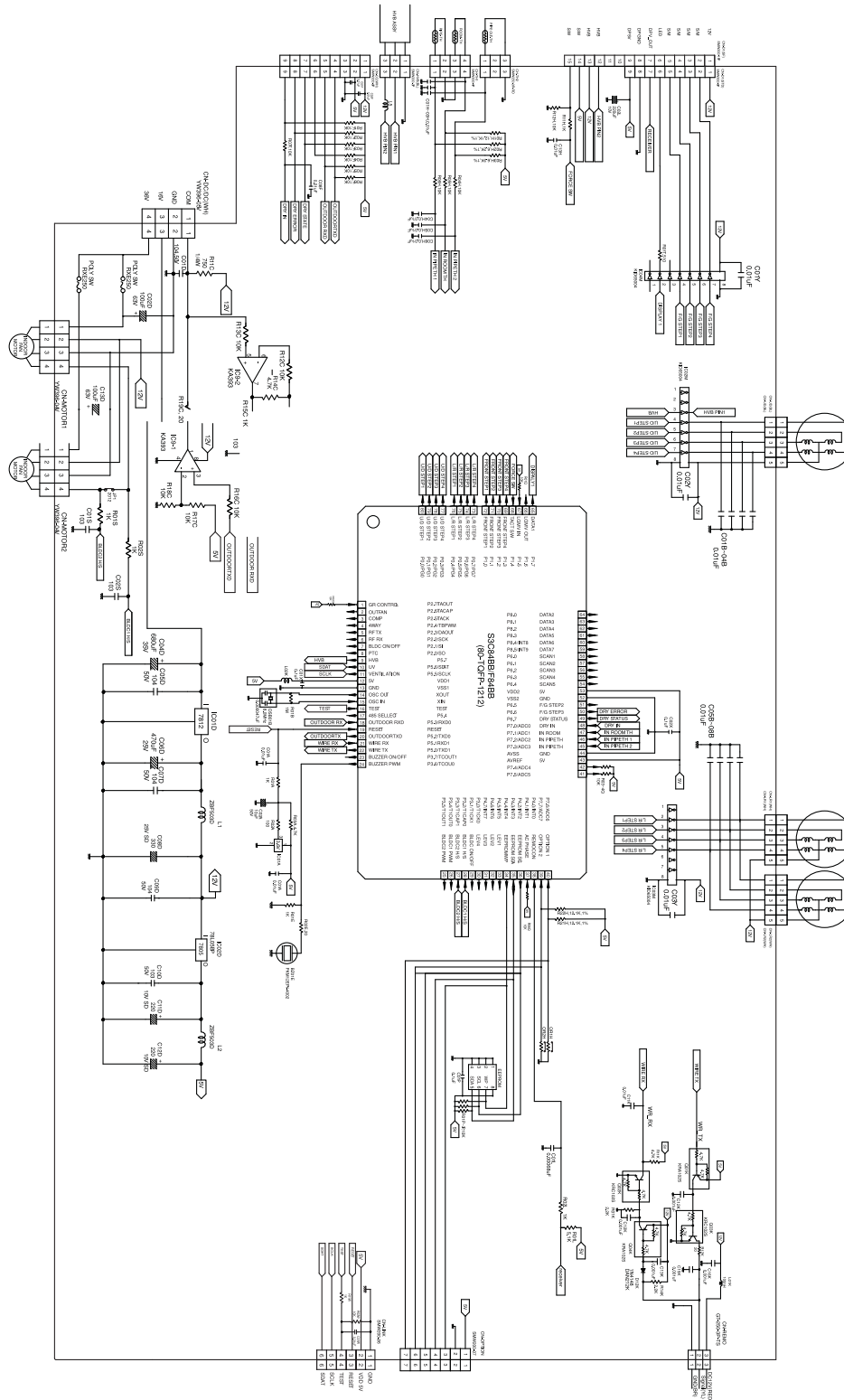

Heat Pump Series/ Cooling Only Series (Outdoor Unit)

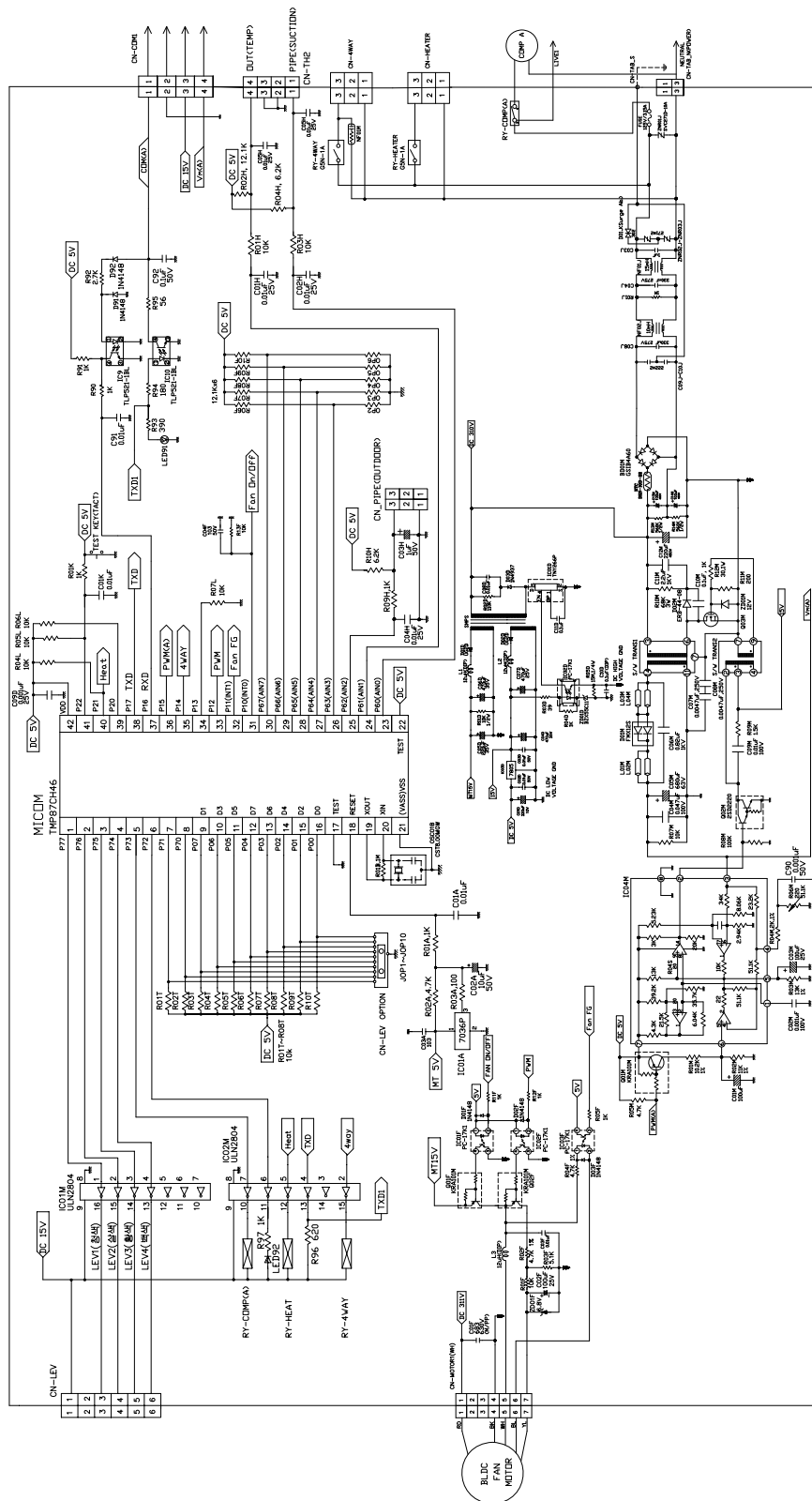

OUTDOOR UNIT P.W.B. ASSEMBLY

• P/No.: 6871A20901C (PCB ASSEMBLY, MAIN)

Top View

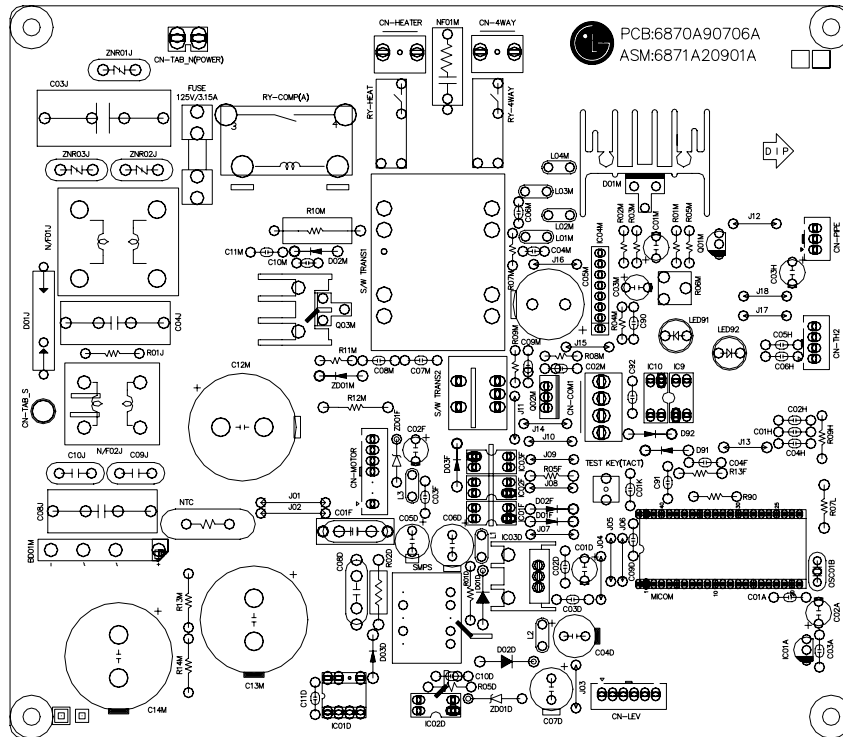

Bottom View

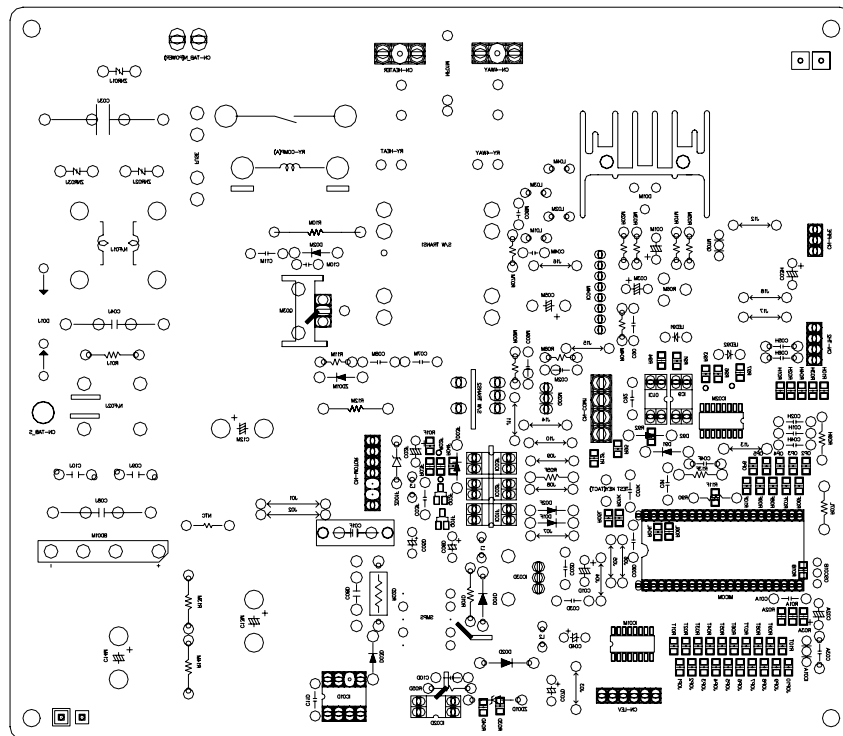

DISPLAY P.W.B. ASM

- P/No.: 6871A20921A (PCB ASSEMBLY)

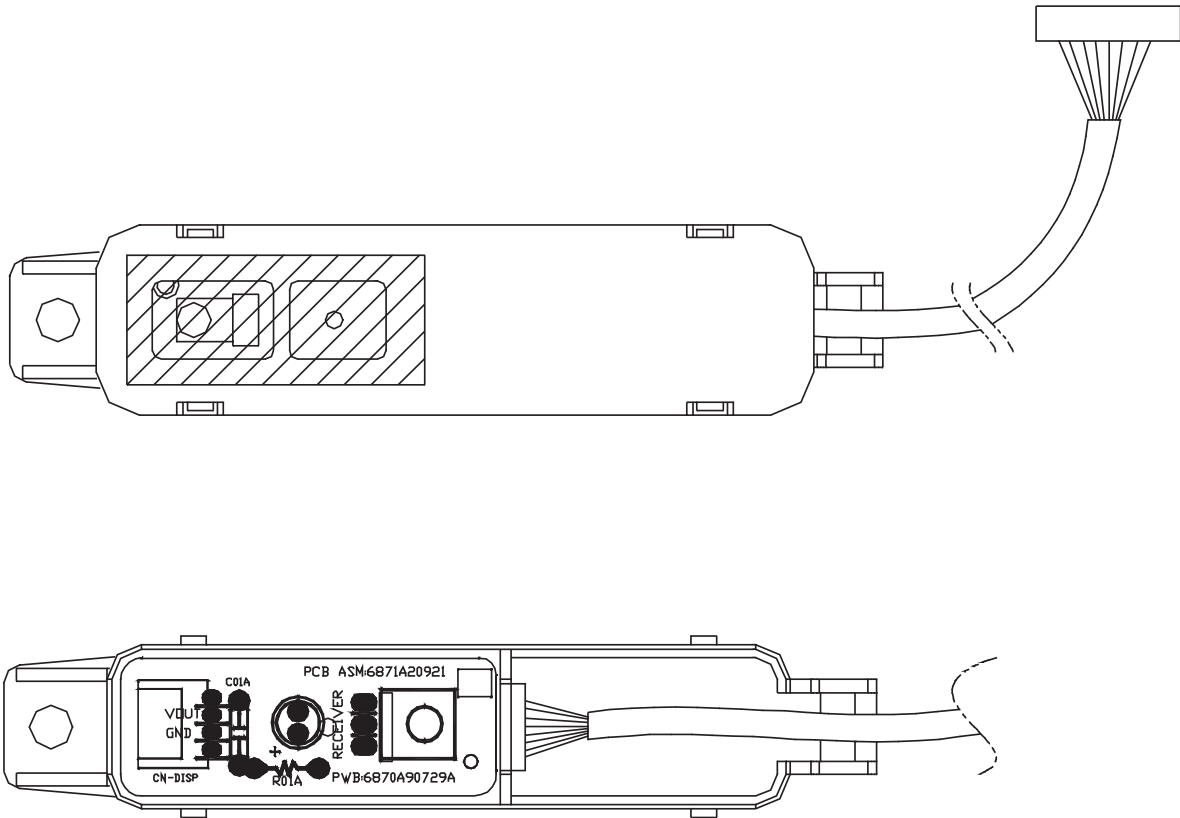

Wiring Diagram

(1) Indoor Unit (Cooling Only Models, & Heating Models)

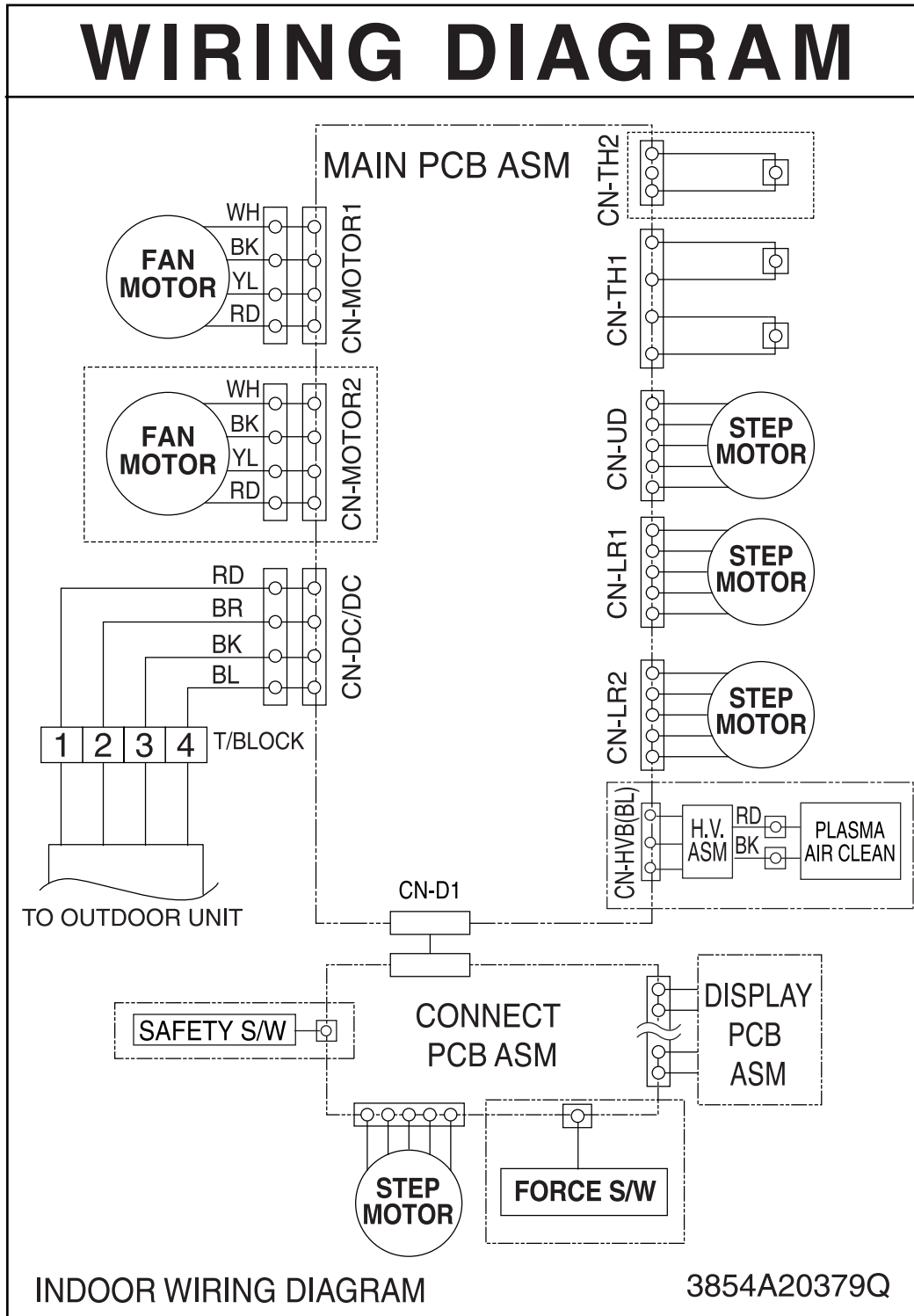

Troubleshooting Guide

Refrigeration Cycle Diagram

(1) Cooling Only Models

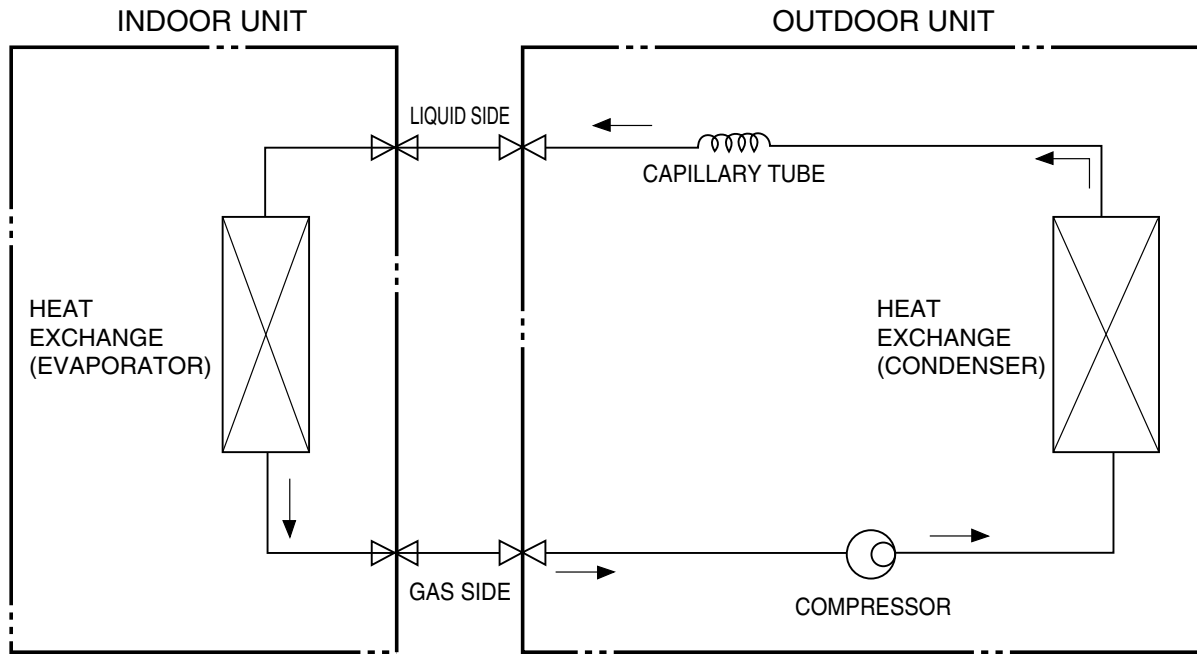

(2) Cooling & Heating Models

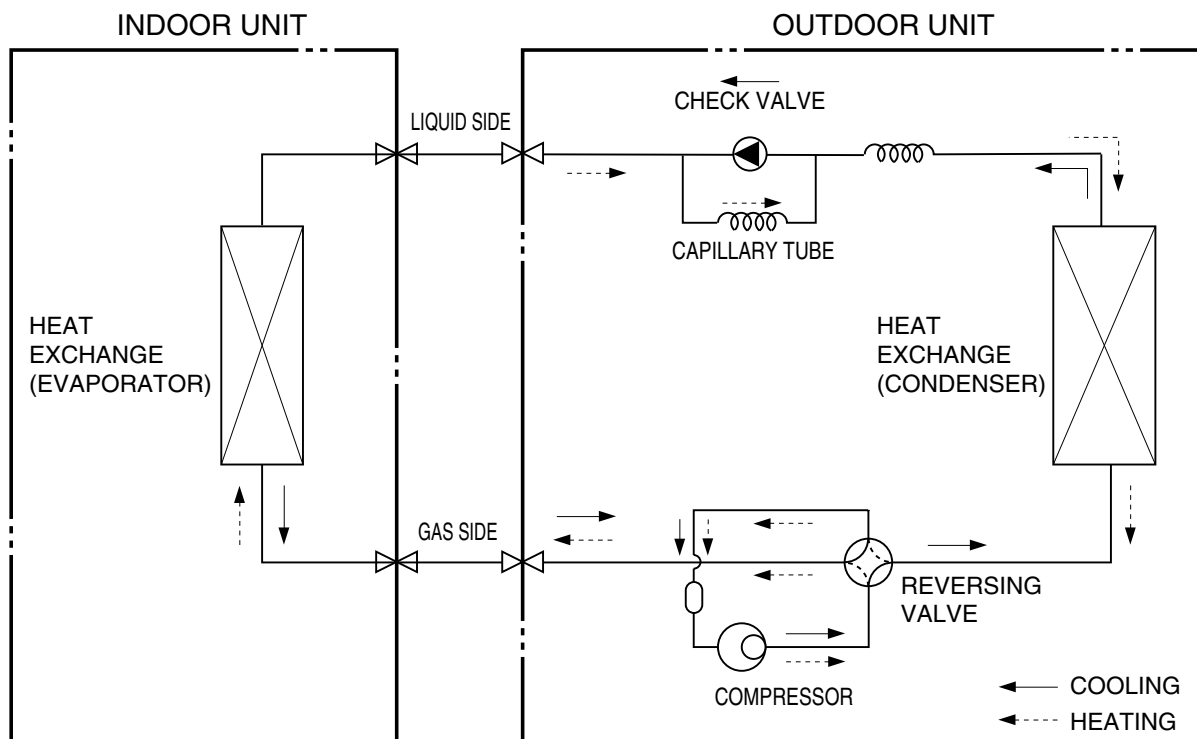

Piping Length and Elevation

Capacity (Btu/h)	Pipe Size		Standard Length m(ft)	Max. Elevation ② m(ft)	Max. length ① m(ft)	Additional Refrigerant g/m(oz/ft)
	Suction	Evap				
9k, 12k	Ø12.7mm(1/2")	Ø6.35mm(1/4")	7.5(25)	7.5(25)	15(49)	20(0.22)

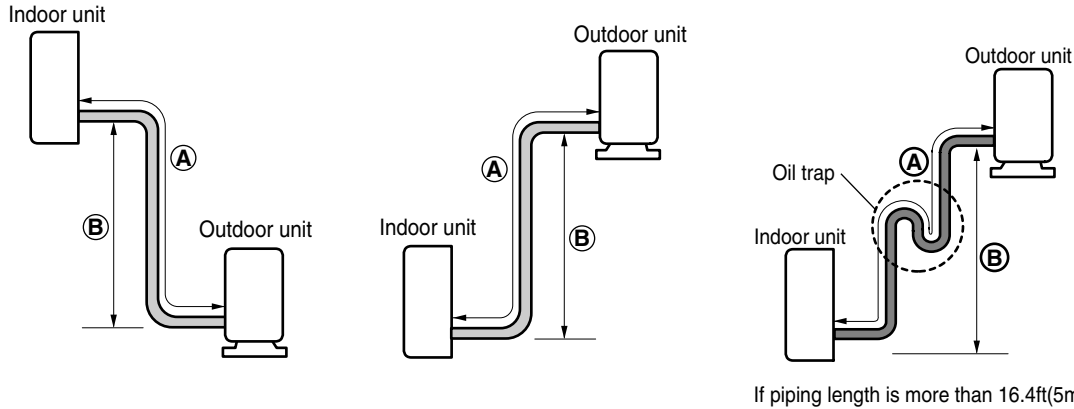

CAUTION: Capacity is based on standard length and maximum allowance length is on the basis of reliability.
 Oil trap should be installed every 16.4~23feets (5~7 meters).

3-way Valve

Pumping Down

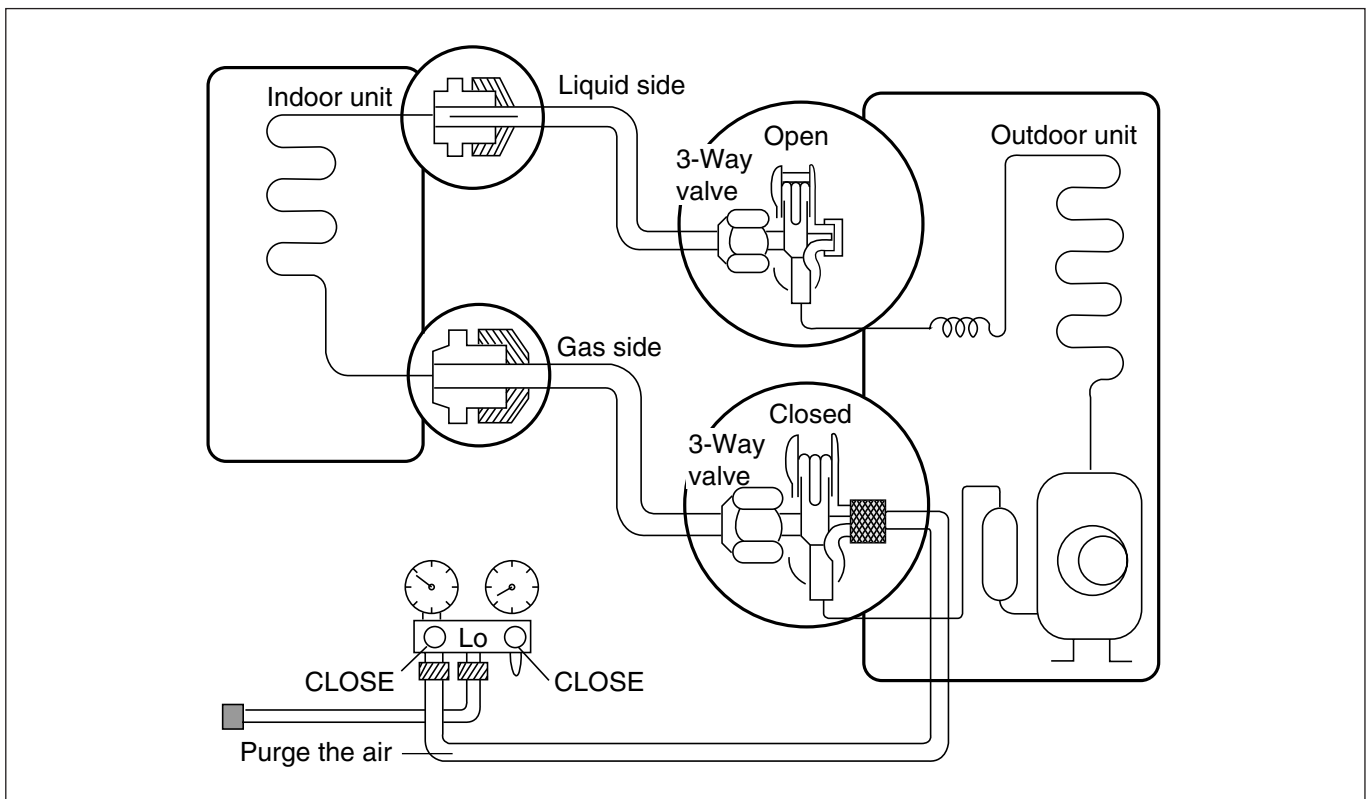

• Procedure

- (1) **Confirm that both liquid side and gas side valves are set to the open position.**
 - Remove the valve stem caps and confirm that the valve stems are in the raised position.
 - Be sure to use a hexagonal wrench to operate the valve stems.
- (2) **Operate the unit for 10 to 15 minutes.**
- (3) **Stop operation and wait for 3 minutes, then connect the charge set to the service port of the Gas side valve.**
 - Connect the charge hose to the service port.
- (4) **Air purging of the charge hose.**
 - Open the low-pressure valve on the charge set slightly to air purge from the charge hose.
- (5) **Set the liquid side valve to the closed position.**
- (6) **Operate the air conditioner in cooling mode and stop it when the gauge indicates 1 kg/cm²g.**
- (7) **Immediately set the Gas side valve to the closed position.**
 - Do this quickly so that the gauge ends up indicating 3 to 5 kg/cm²g.
- (8) **Disconnect the charge set, and mount the Liquid side and Gas side valve's stem nuts and the service port nut.**
 - Use torque wrench to tighten the service port nut to a torque of 1.8 kg.m.
 - Be sure to check for gas leakage.

1) Re-air purging

(Re-installation)

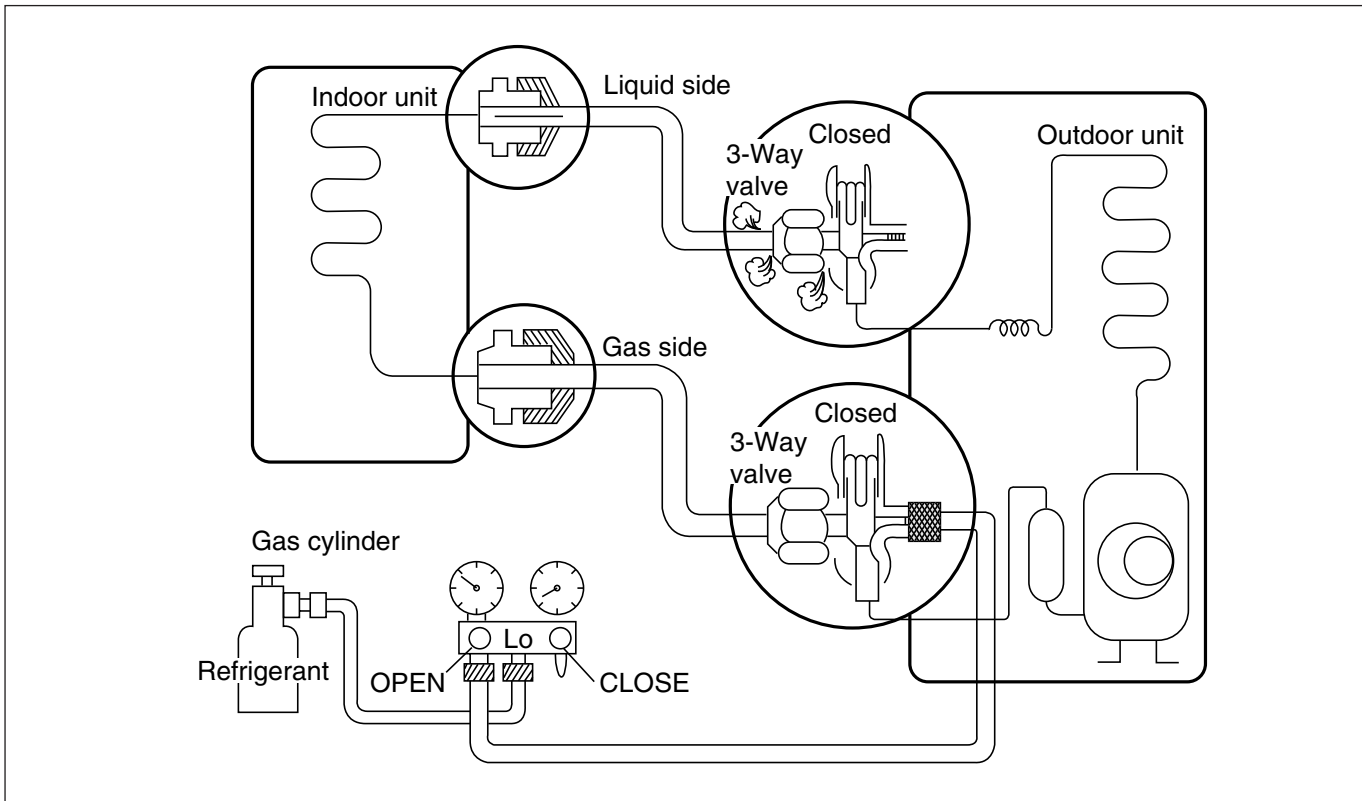

• Procedure

(1) Confirm that both the liquid side valve and the gas side valve are set to the closed position.

(2) Connect the charge set and a gas cylinder to the service port of the Gas side valve.

- Leave the valve on the gas cylinder closed.

(3) Air purging.

- Open the valves on the gas cylinder and the charge set. Purge the air by loosening the flare nut on the liquid side valve approximately 45° for 3 seconds then closing it for 1 minute; repeat 3 times.
- After purging the air, use a torque wrench to tighten the flare nut on liquid side valve.

(4) Check for gas leakage.

- Check the flare connections for gas leakage.

(5) Discharge the refrigerant.

- Close the valve on the gas cylinder and discharge the refrigerant until the gauge indicates 3 to 5 kg/cm²g.

(6) Disconnect the charge set and the gas cylinder, and set the Liquid side and Gas side valves to the open position.

- Be sure to use a hexagonal wrench to operate the valve stems.

(7) Mount the valve stem nuts and the service port nut.

- Use torque wrench to tighten the service port nut to a torque of 1.8 kg.m.
- Be sure to check for gas leakage.

*** CAUTION:**

Do not leak the gas in the air during Air Purging.

2) Balance refrigerant of the 3-way valve

(Gas leakage)

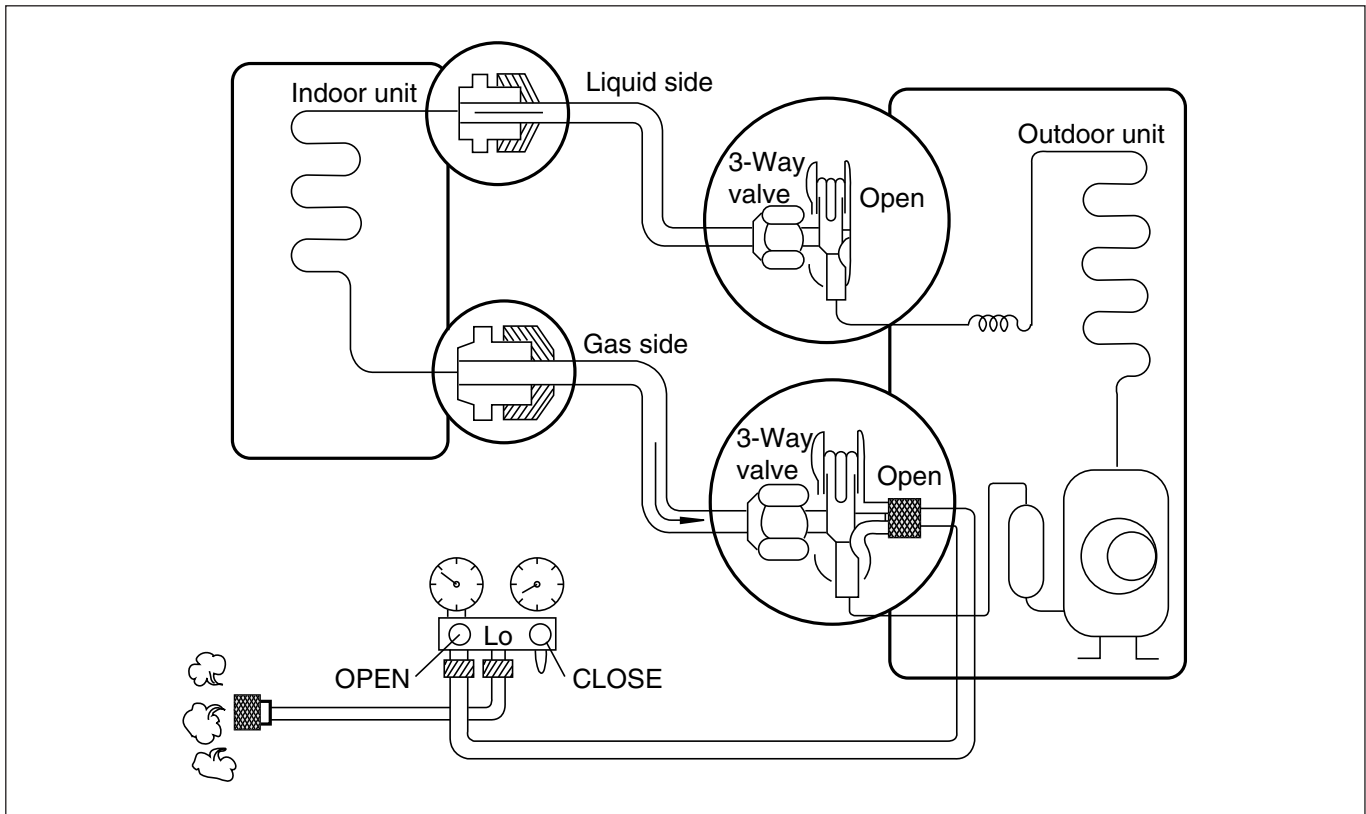

• Procedure

- (1) Confirm that both the liquid side and gas side valves are set to the back seat.
- (2) Connect the charge set to the 3-way valve's port.
 - Leave the valve on the charge set closed.
 - Connect the charge hose to the service port.
- (3) Open the valve (Lo side) on the charge set and discharge the refrigerant until the gauge indicates 0 kg/cm²G.
 - If there is no air in the refrigerant cycle (the pressure when the air conditioner is not running is higher than 1 kg/cm²G), discharge the refrigerant until the gauge indicates 0.5 to 1 kg/cm²G. If this is the case, it will not be necessary to apply a evacuation.
 - Discharge the refrigerant gradually; if it is discharged too suddenly, the refrigeration oil will also be discharged.

2. Evacuation

(All amount of refrigerant leaked)

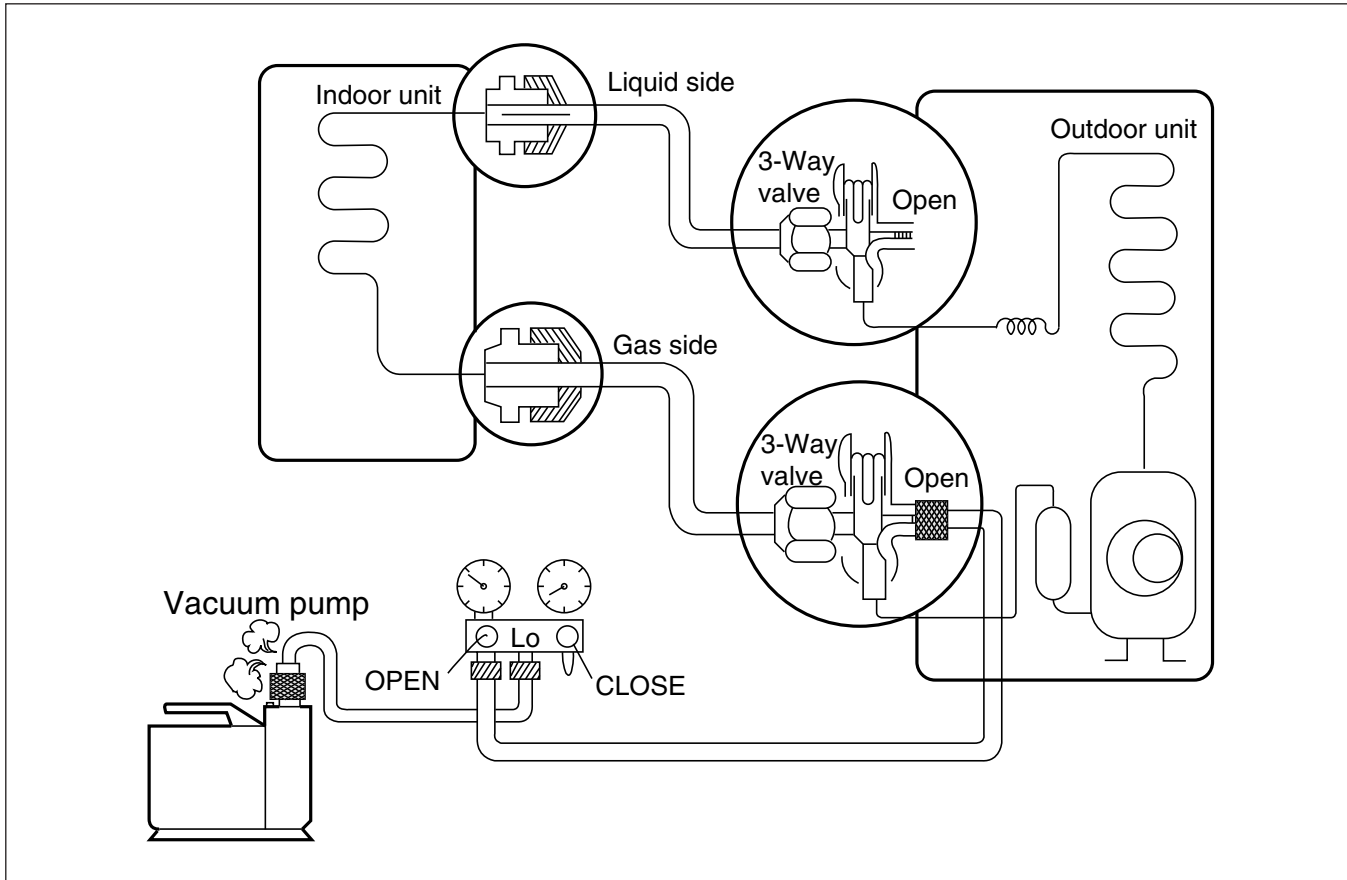

• Procedure

- (1) Connect the vacuum pump to the center hose of charge set center hose
- (2) Evacuation for approximately one hour.
 - Confirm that the gauge needle has moved toward -76 cmHg (vacuum of 4 mmHg or less).
- (3) Close the valve (Lo side) on the charge set, turn off the vacuum pump, and confirm that the gauge needle does not move (approximately 5 minutes after turning off the vacuum pump).
- (4) Disconnect the charge hose from the vacuum pump.
 - Vacuum pump oil.
If the vacuum pump oil becomes dirty or depleted, replenish as needed.

3. Gas Charging

(After Evacuation)

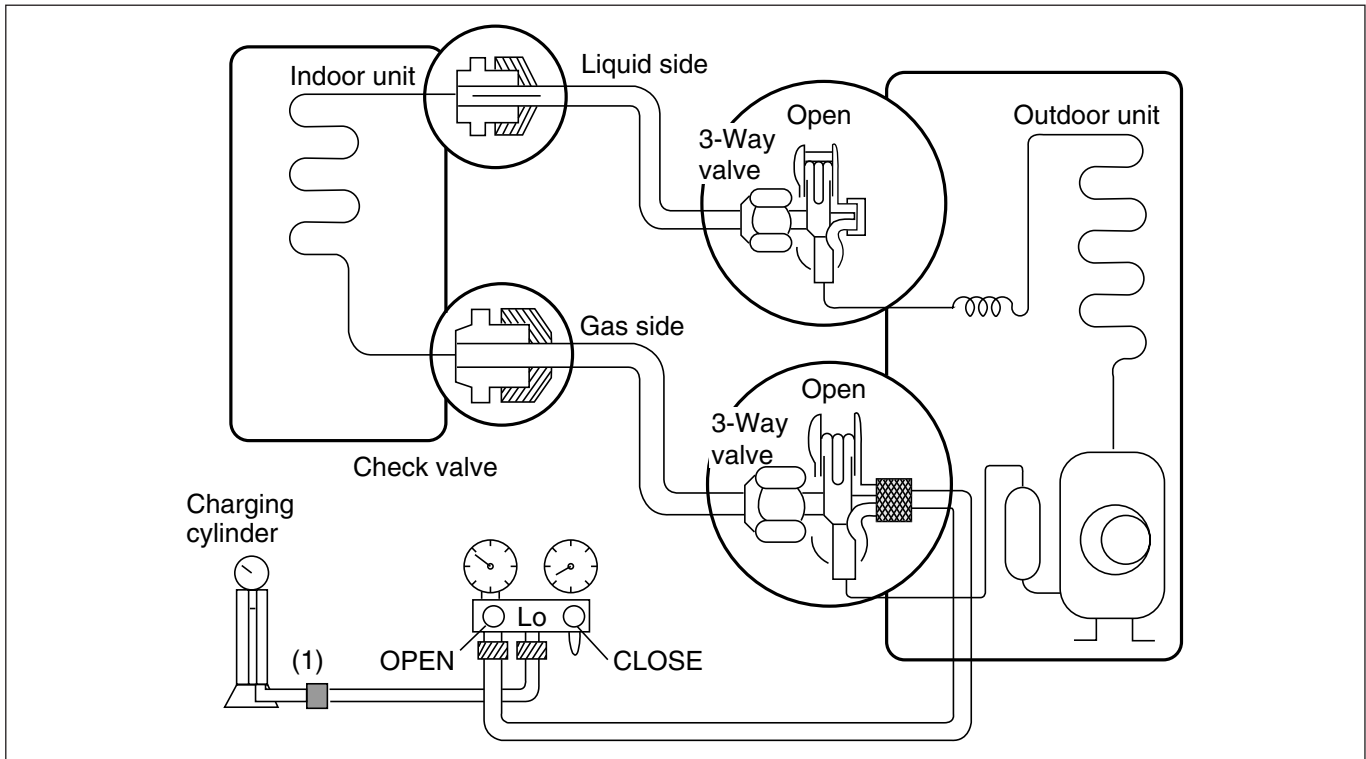

• Procedure

(1) Connect the charge hose to the charging cylinder.

- Connect the charge hose which you disconnected from the vacuum pump to the valve at the bottom of the cylinder.
- If you are using a gas cylinder, also use a scale and reverse the cylinder so that the system can be charged with liquid.

(2) Purge the air from the charge hose.

- Open the valve at the bottom of the cylinder and press the check valve on the charge set to purge the air. (Be careful of the liquid refrigerant). The procedure is the same if using a gas cylinder.

(3) Open the valve (Lo side on the charge set and charge the system with liquid refrigerant.

- If the system can not be charged with the specified amount of refrigerant, it can be charged with a little at a time (approximately 150g each time) while operating the air conditioner in the cooling cycle; however, one time is not sufficient, wait approximately 1 minute and then repeat the procedure (pumping down-pin).

This is different from previous procedures. Because you are charging with liquid refrigerant from the gas side, absolutely do not attempt to charge with larger amounts of liquid refrigerant while operating the air conditioner.

(4) Immediately disconnect the charge hose from the 3-way valve's service port.

- Stopping partway will allow the gas to be discharged.
- If the system has been charged with liquid refrigerant while operating the air conditioner turn off the air conditioner before disconnecting the hose.

(5) Mount the valve stem nuts and the service port nut.

- Use torque wrench to tighten the service port nut to a torque of 1.8 kg.m.
- Be sure to check for gas leakage.

! CAUTION

**This unit is charged with R-410A.
Pay attention not to charge R-22.**

Additional gas charging

(Gas leakage)

- When refrigerant is insufficient by leakage, recharge the unit with the refrigerant up to normal operating suction pressure.
- Use the graph or the equation below to get operating suction pressure according to indoor and outdoor temperature.

Suction pressure was measured at 3-way valve service port after operating the unit for 10 minutes.

The method of using graph

- Find outdoor temperature.
- Find indoor temperature onto the curve of outdoor temperature.
- Read suction pressure at the axis of ordinates.

The method of using equation

- Calculate suction pressure after putting indoor and outdoor temperature into the equation.

Operating Suction Pressure (For R410A) (According to Indoor & Outdoor Temperature)

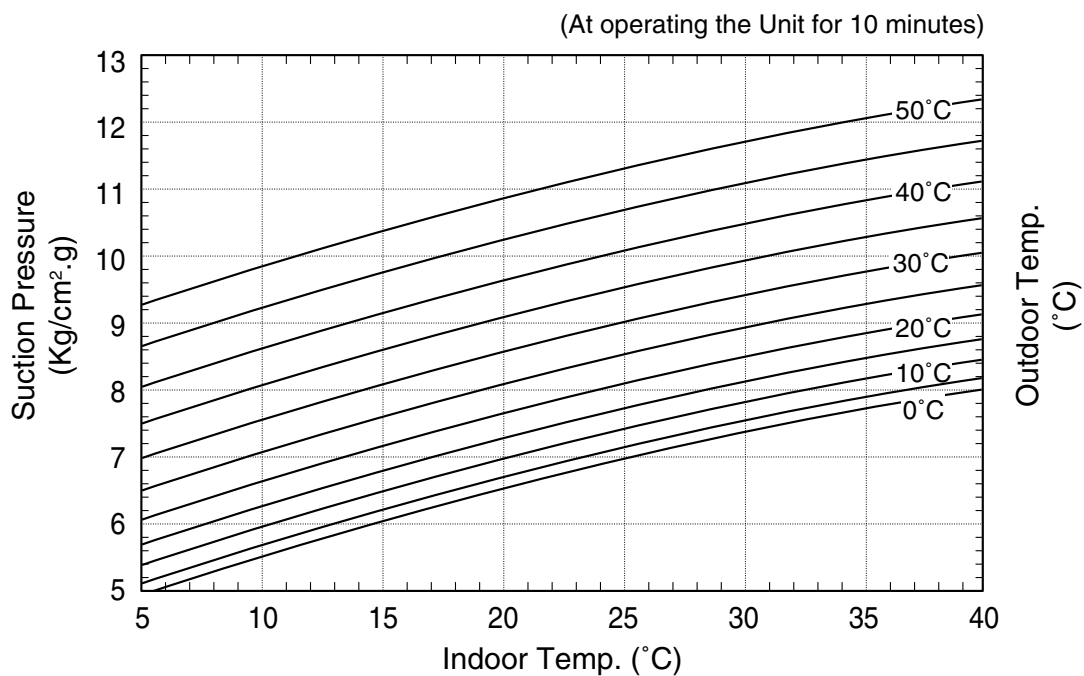

$$P = 3 + 0.0123 \times T_{out}^{1.5} + 0.8 \times T_{in}^{0.5}$$

Where, P : Suction Pressure(kg/cm².g)
 Tout : Outdoor Temperature(°C)
 Tin : Indoor Temperature(°C)

Cycle Parts

Trouble analysis

1. Check temperature difference between intake and discharge air and operating current.

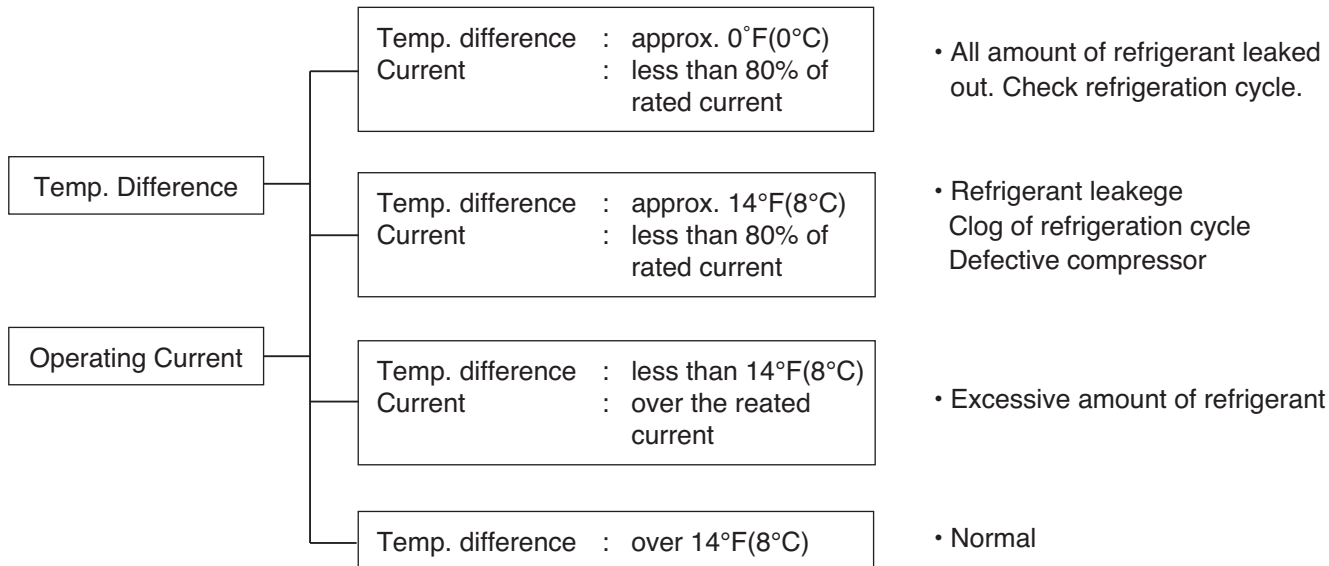

NOTICE

Temperature difference between intake and discharge air depends on room air humidity. When the room air humidity is relatively higher, temperature difference is smaller. When the room air humidity is relatively lower temperature difference is larger.

2. Check temperature and pressure of refrigeration cycle.

Suction pressure (Compared with the normal value)	Temperature (Compared with the normal valve)	Cause of Trouble	Description
Higher	High	Defective compressor Defective 4-way reverse valve	Current is low.
	Normal	Excessive amount of refrigerant	High pressure does not quickly rise at the beginning of operation.
Lower	Higher	Insufficient amount of refrigerant (Leakage)	Current is low.
		Clogging	Current is low.

NOTICE

- The suction pressure is usually 4.5~6.0 kg/cm²G(Cooling) at normal condition.
- The temperature can be measured by attaching the thermometer to the low pressure tubing and wrap it with putty.

Electronic Parts (9k model)

Product does not operate at all.

(* Refer to Electronic Control Device drawing and Schematic diagram.)

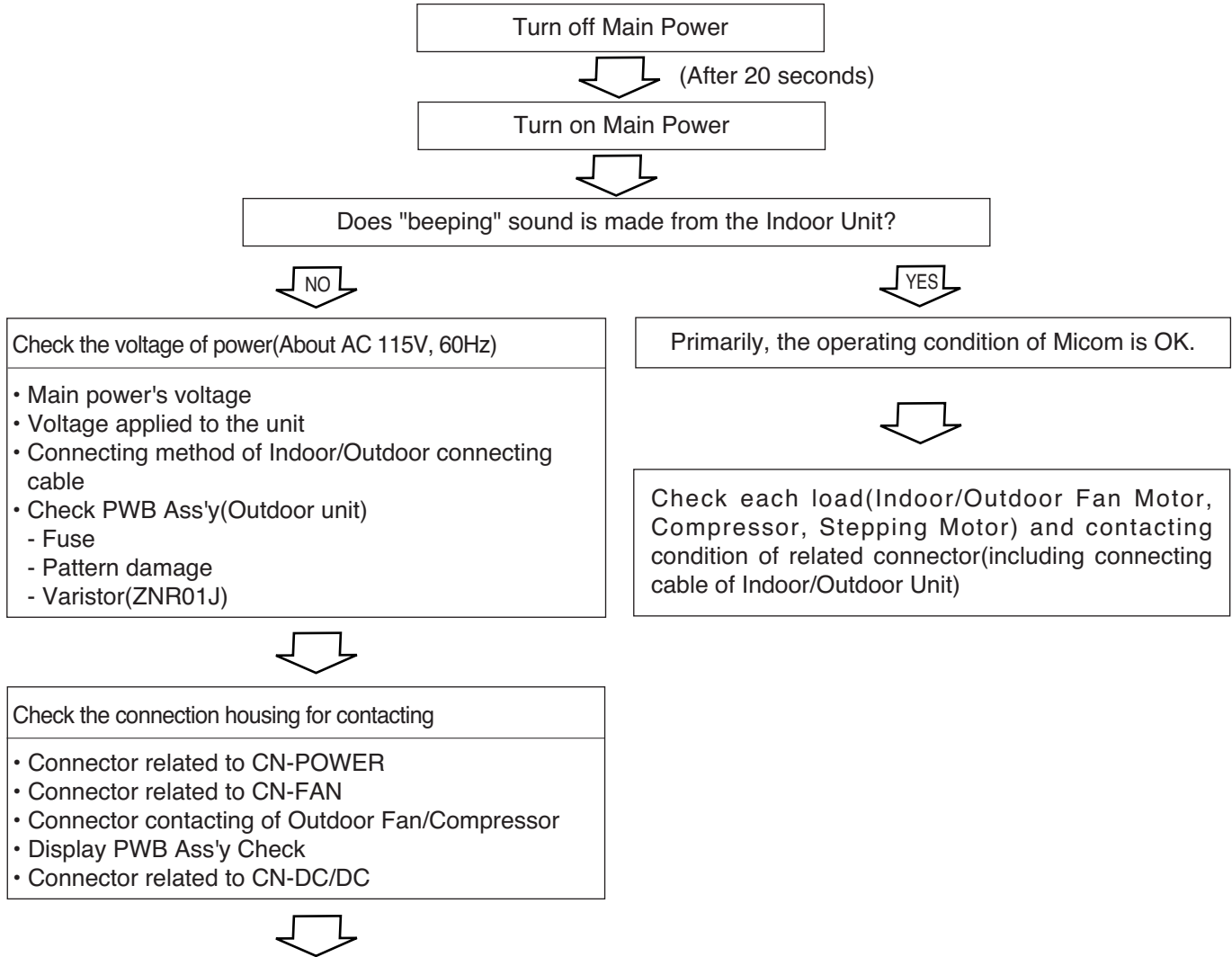

PCB Board Operation Check		
Items	Content	Remedy
<ul style="list-style-type: none"> • Power Transformer (Outdoor unit) - Input Voltage - Output Voltage <li style="text-align: center;">↓ • IC01D(7812) Output (Indoor/Outdoor unit) <li style="text-align: center;">↓ • IC02D(7805) Output (Indoor unit) • IC03D(7805) Output (Outdoor unit) <li style="text-align: center;">↓ • IC01A(KIA7036, Reset IC) • OSC01B(4MHz) (Indoor/Outdoor unit) 	<ul style="list-style-type: none"> - About AC115V±10% - Check the power voltage - About DC15V±3 • DC +12V • DC +5V • Voltage of Outdoor unit Micom No. 18, Voltage of Indoor unit Micom No. 43 and soldering condition 	<ul style="list-style-type: none"> • Replace SMPS Module • Replace IC01D • Replace IC02D(Indoor unit) IC03D(Outdoor unit) • Replace faulty parts

The product is not operate with the remote controller.

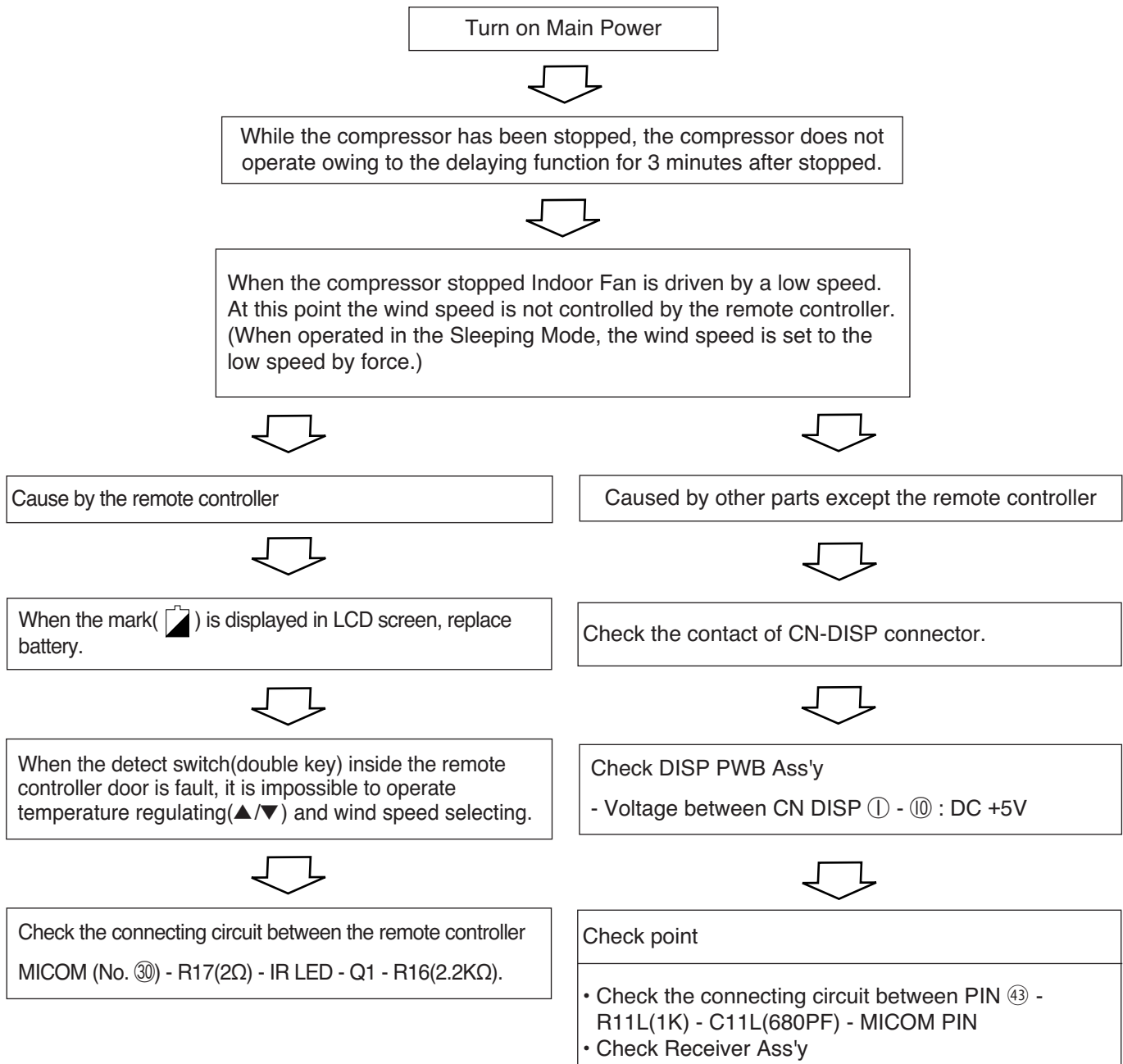

Compressor/Outdoor Fan are unable to drive.

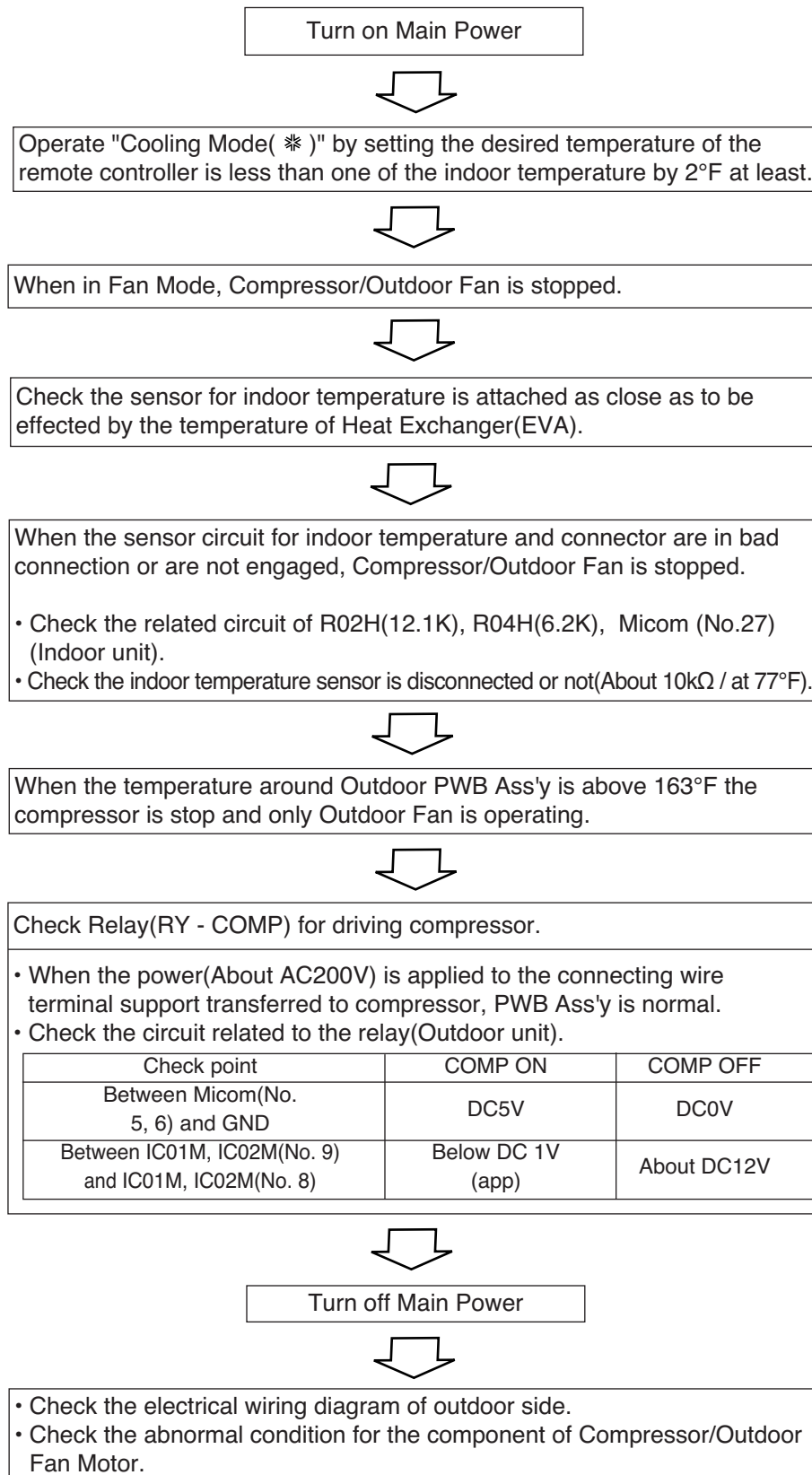

When indoor Fan does not operate.

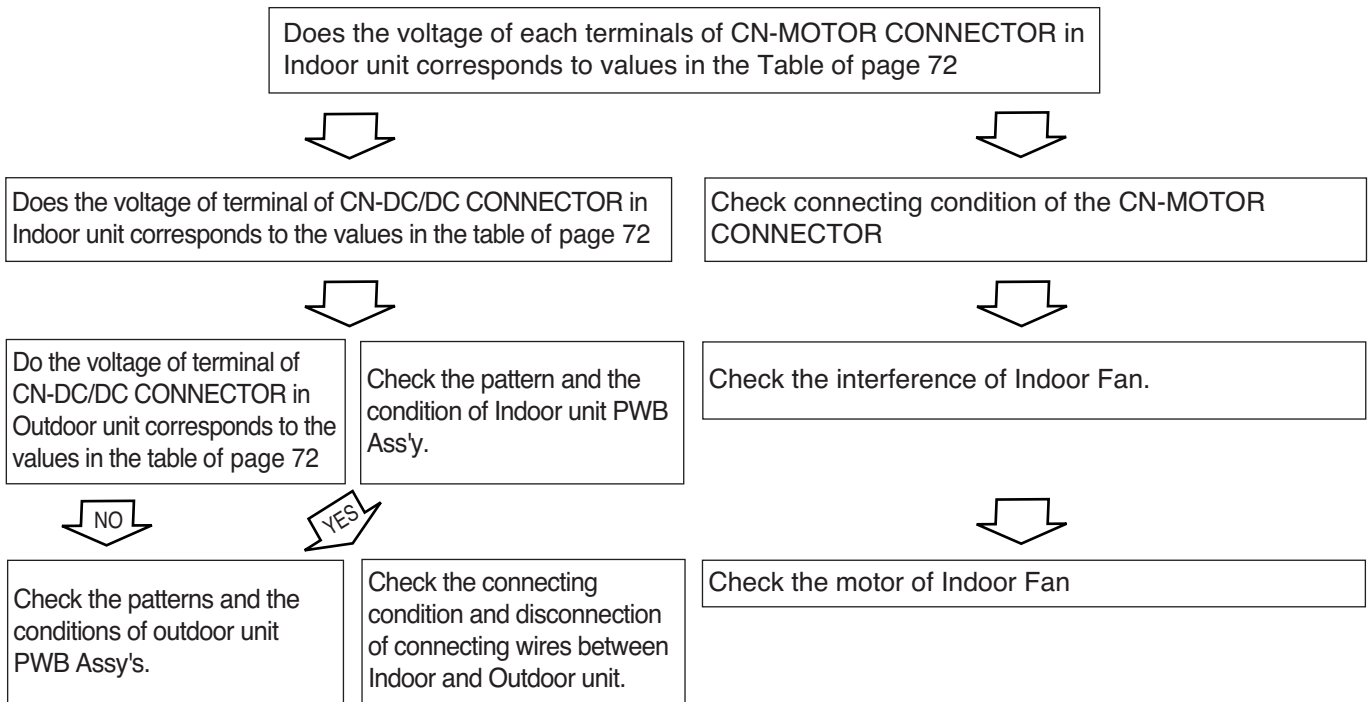

- ※ Indoor Fan may be stopped in the Soft Dry Mode(change to the Cooling Operation Mode).
- ※ Indoor Fan is to be stopped when Indoor pipe(coil) temperature is lower than 79°F.
(At that times, Defrost indicator is turned on)

When Vertical Louver does not operate.

- Confirm that the Vertical Louver is normally geared with the shaft of Stepping Motor.
- If the regular torque is detected when rotating the Vertical Louver with hands ⇒ Normal



- Check the connecting condition of CN-UP/DOWN Connector
- Check the soldering condition(on PWB) of CN-UP/DOWN Connector



Check the operating circuit of the Vertical Louver

- Confirm that there is DC +12V between pin⑤(REDF) of CN-UP/DOWN and GND.
- Confirm that there is a soldering short at following terminals.
 - Between ⑦⑦, ⑦⑧, ⑦⑨ and ⑧⑩ of MICOM
 - Between ④, ⑤, ⑥ and ⑦ of IC02M
 - Between ⑩, ⑪, ⑫ and ⑬ of IC01M
 - Between ①, ②, ③, ④ and ⑤ of CN-UP/DOWN



If there are no problems after above checks

- Confirm the assembly conditions that are catching and interfering parts in the rotation radial of the Vertical Louver

When a communication error occurs.

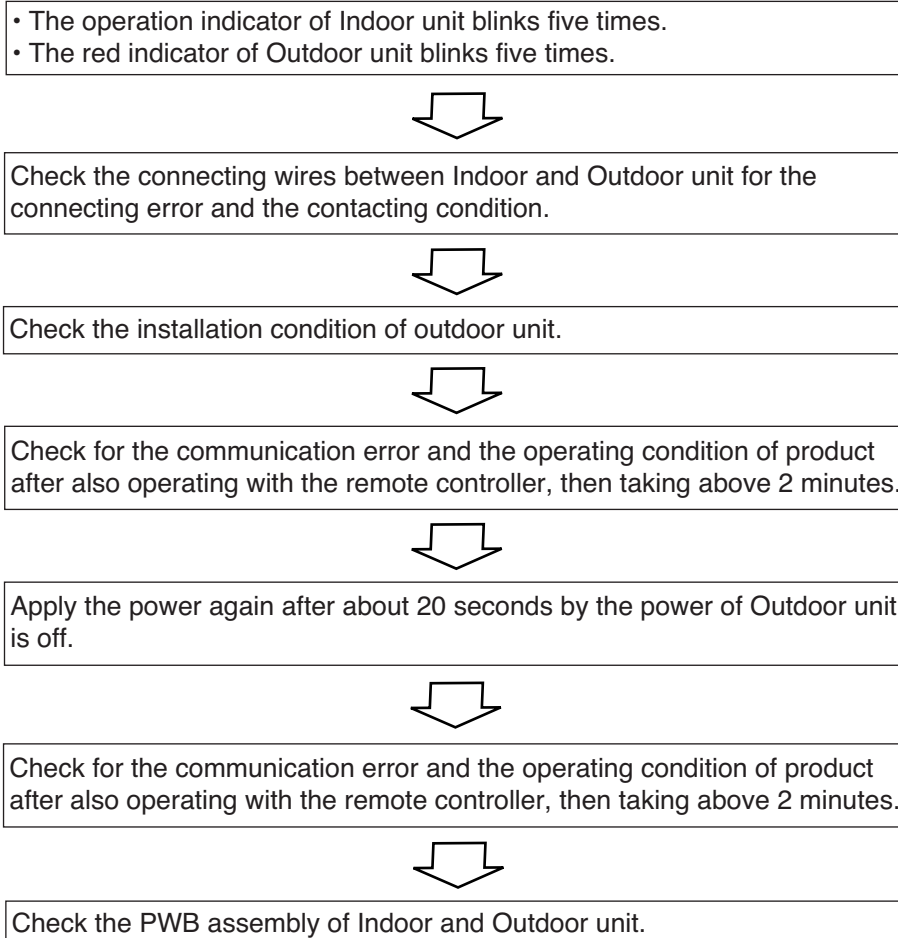

Caution: If the connecting wires of Indoor and Outdoor unit are not connected within 2 minutes after the power of Outdoor unit is applied, a communication error will occur. Therefore, the power should be applied after connecting them.

The phenomena in case of connecting error

INDOOR UNIT

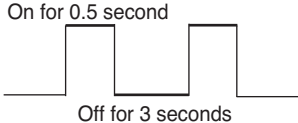
Connector Type	Condition	Phenomena
CN-DC/DC  ① Blue ② Black ③ Brown ④ Red	Open and connecting error	<ul style="list-style-type: none"> The same as the phenomenon of Outdoor Unit.
CN-MOTOR	Open	<ul style="list-style-type: none"> The indoor fan does not operate. The operation indicator of Indoor unit blinks 8 times.
CN-UP/DOWN	Open	<ul style="list-style-type: none"> The up/down vane does not operate.
	Short between terminals	<ul style="list-style-type: none"> The up/down vane does not smoothly operate.
CN-DISP	Open	<ul style="list-style-type: none"> It does not operate with a remote controller.
CN-TH	Open	<ul style="list-style-type: none"> The operation indicator blinks once.  <ul style="list-style-type: none"> The compressor and the outdoor fan stop. The indoor fan speed is low.
	Short between terminals (③ and ④) of ROOM-TH.	<ul style="list-style-type: none"> The operation indicator blinks once (on for 0.5 second, off for 3 seconds). The compressor operates continuously regardless of the setting temperature and the variation of room temperature.
	Short between terminals (① and ②) of PIPE-TH.	<ul style="list-style-type: none"> The operation indicator blinks once (on for 0.5 second, off for 3 seconds) Continuous operation

OUTDOOR UNIT

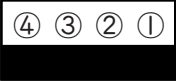
Connector Type	Condition	Phenomena
CN-POWER	OPEN	<ul style="list-style-type: none"> All functions stop. The operation with the remote controller, forced and test one do not operate.
	Connecting reversely	<ul style="list-style-type: none"> PWB pattern is damaged when applying the power.
RY-COMP terminal	OPEN	<ul style="list-style-type: none"> All functions stop or the compressor does not operate. The operation with the remote controller, forced and test one do not operate.
	Connecting reversely	<ul style="list-style-type: none"> All functions stop. The operation with the remote controller, forced and test one do not operate.
CN-TRANS	OPEN	<ul style="list-style-type: none"> All functions stop. The operation with the remote controller, forced and test one do not operate.
CN-FAN	OPEN	<ul style="list-style-type: none"> The Indoor Fan does not operate.
The connecting wire of CN-DC/DC, and Indoor and Outdoor Unit  ① Blue ② Black ③ Brown ④ Red	OPEN	<ul style="list-style-type: none"> All functions stop. The operation with the remote controller, forced and test one do not operate.
	Connecting error (① ↔ ②)	<ul style="list-style-type: none"> The only signal of remote controller operation/stop is inputted, but the product does not operate. The RED indicator of outdoor unit blinks 5 times after 2 minutes with applying the power.
	Connecting error (① ↔ ③)	<ul style="list-style-type: none"> The beep sound, such as "beep, beep, beep, beep, beep", occurs periodically in Indoor unit. The signal input of a remote controller and operation of product is impossible. The RED indicator blinks 5 times after 2 minutes with applying the power.
	Connecting error (① ↔ ④)	<ul style="list-style-type: none"> The signal of remote controller is inputted, but the product does not operate. The RED indicator of outdoor unit and the operation indicator of indoor one blinks 5 times after 2 minutes with applying the power.
	Connecting error (② ↔ ③)	<ul style="list-style-type: none"> No power for Indoor unit. The signal input of the remote controller and operation of product is impossible. The thermal protector of the Power Trans operates when let it alone for long time.
	Connecting error (② ↔ ④)	<ul style="list-style-type: none"> The signal of the remote controller is inputted. The fuse and Q61 in the Outdoor unit are damaged when the indoor fan is operated.
	Connecting error (③ ↔ ④)	<ul style="list-style-type: none"> No power for Indoor unit. The signal input of the remote controller and operation of product is impossible. The RED indicator of the Outdoor unit blinks 5 times after 2 minutes with applying the power.

Voltage of Connectors according to Indoor Fan Speed

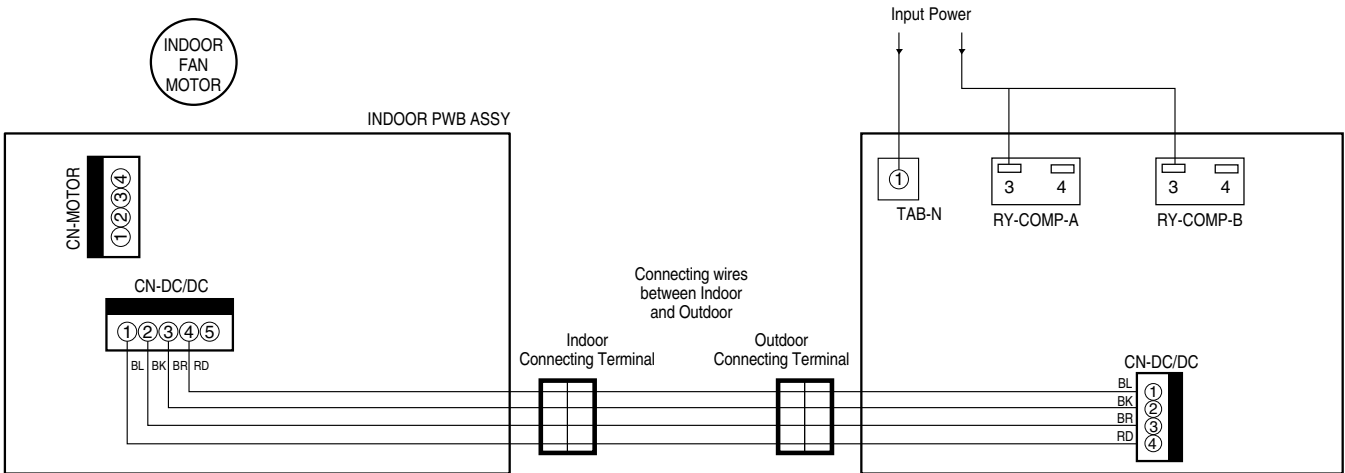

	No. of pins		12k				
			DC Voltage(±10%)				
	+	-	S-Hi	Hi	Med	Low	Off
INDOOR CN- MOTOR	4	3	35.5	32.96	25.17	17.28	0
	2	3	11.97	11.97	11.97	11.97	11.97
INDOOR CN- DC/DC	4	2	35.5	32.96	25.17	17.28	0
	3	2	15.87	15.87	15.87	15.87	15.87
OUTDOOR CN- DC/DC	4	2	35.5	32.96	25.17	17.28	0
	3	2	15.87	15.87	15.87	15.87	15.87

Exploded View

Indoor Unit

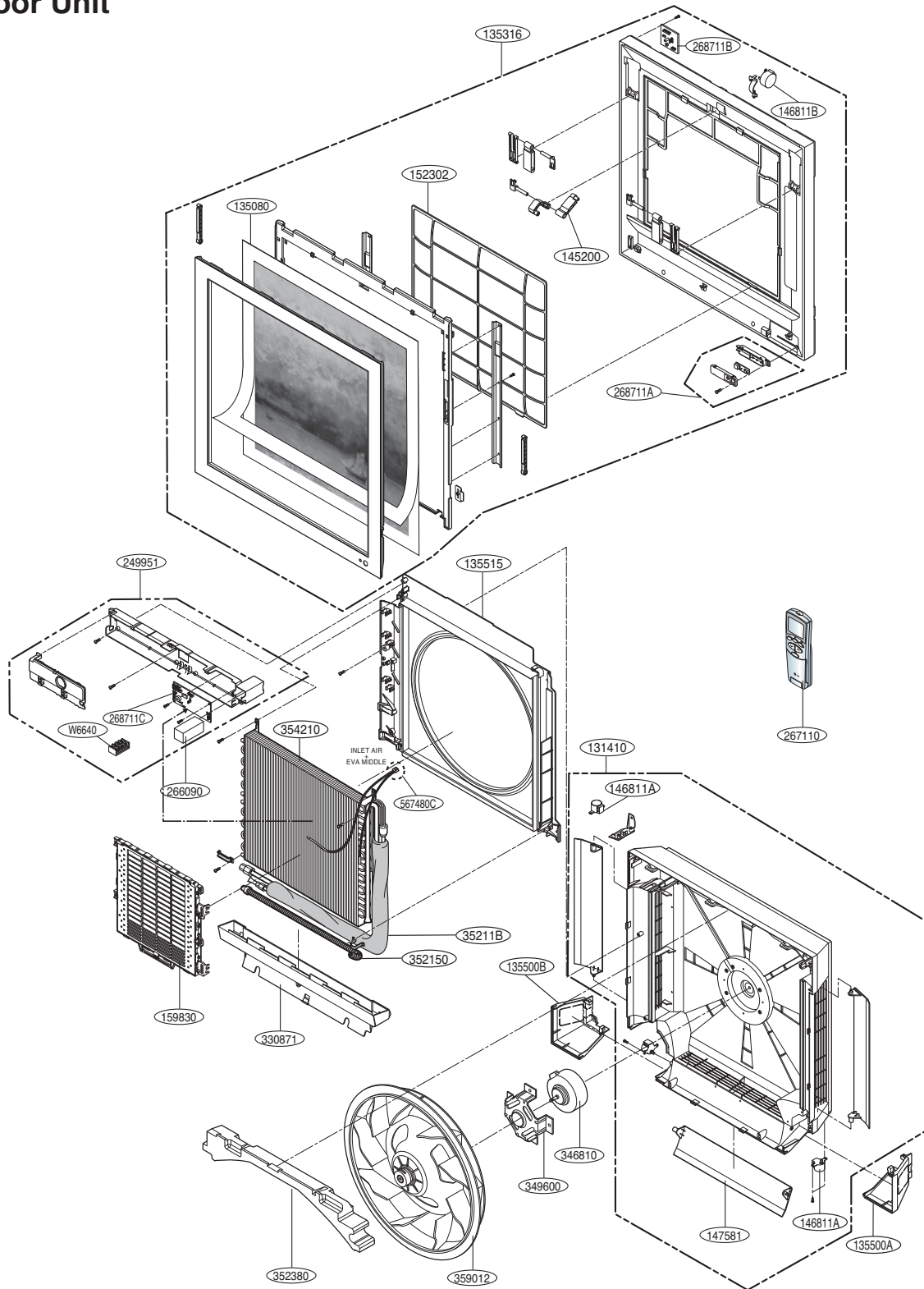

NOTE) *Please ensure GCSC since the replacement parts may be changed depending upon the buyer's request.
Please check the correct parts in View RPL(Replacement Part List)on GCSC.
(GCSC Website <http://biz.lgservice.com>)

2. Outdoor Unit (C/O Series)

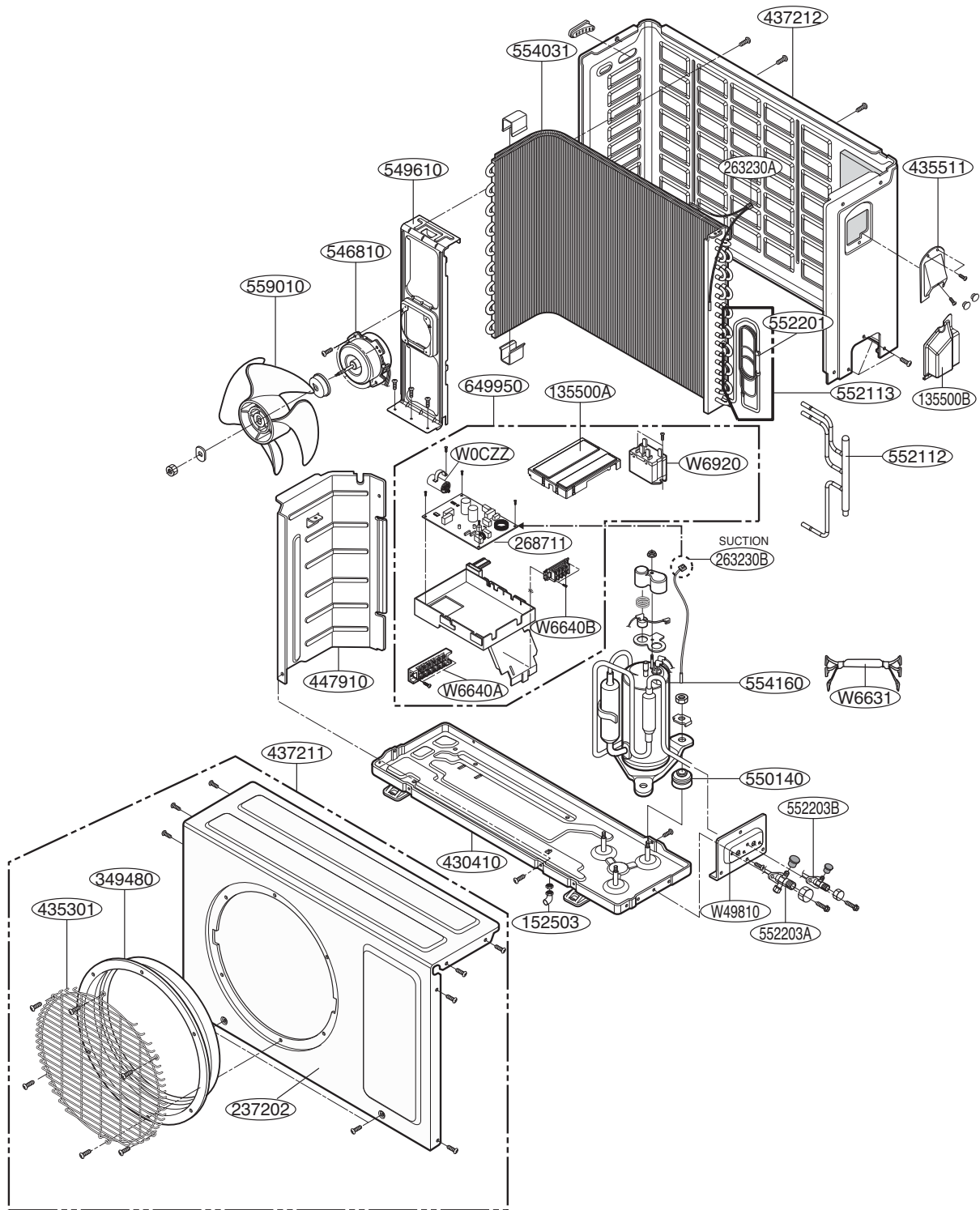

NOTE) *Please ensure GCSC since the replacement parts may be changed depending upon the buyer's request. Please check the correct parts in View RPL(Replacement Part List)on GCSC. (GCSC Website <http://biz.lgservice.com>)



US	1. Please call the installing contractor of your product, as warranty service will be provided by them. 2. If you have service issues that have not been addressed by the contractor, please call 1-888-865-3026.
CANADA	Service call Number # : (888) LG Canada, (888) 542-2623

P/NO : 3828A20926C

FEBRUARY, 2010