

This Owner's Manual is provided and hosted by [Appliance Factory Parts](#).

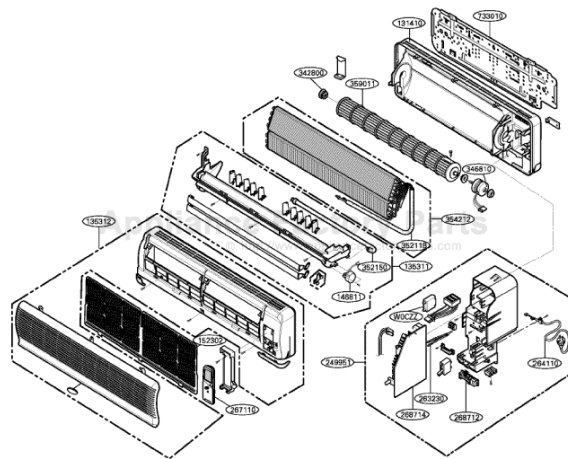

LG AG1AC11BKM Owner's Manual

[Shop genuine replacement parts for LG AG1AC11BKM](#)



[Find Your LG Air Conditioner Parts - Select From 2328 Models](#)

----- Manual continues below -----

Operation Details

(1) The function of main control

1. Time Delay Safety Control

- 3min... The compressor is ceased for 3minutes to balance the pressure in the refrigeration cycle.
(Protection of compressor)
- 2sec... The indoor fan is ceased for 2sec. to prevent relay noise.
(Protection of fan relay and micro chip)
- 30sec... The 4-way valve is ceased for 30sec. to prevent the refrigerant-gas abnormal noise when the Heating operation is OFF or switched to the other operation mode.

2. Airflow Direction Control

- This function is to swing the louver up and down automatically and to set it at the desired position.
- The procedure is as the following.
 - 1st; Press the ON/OFF Button to operate the product.
 - 2nd; Press the Airflow Direction Control Button to swing the louver up and down automatically.
 - 3rd; Reprress the Airflow Direction Control Button to set the louver as the desired position.

Operating Mode		Louver Position
Cooling	Start	2
	Auto. Swing	1 ; >4
Heating	Start	5
	Auto. Swing	3 ; >6

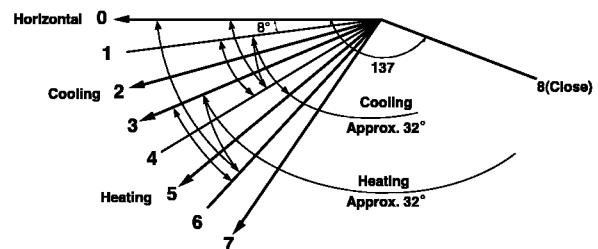

3. Cooling Mode Operation

- When selecting the Cooling (※) Mode Operation, the unit will operate according to the setting by the remote controller and the operation diagram is as following.

Intake Air temp.					
COMP. ON (SET TEMP.+0.5°C)					
COMP. OFF (SET TEMP.-0.5°C)					
INDOOR FAN SPEED	Selecting fan speed	Low	Selecting fan speed	Low	Selecting fan speed
COMPRESSOR	ON	OFF	ON	OFF	ON

4. Cooling or Heating Mode with Sleep Mode Auto Operation

- When selecting the Cooling (※) or the Heating (※) combined with the Sleep Mode Auto Operation (☆), the operation diagram is as following.

• Cooling Mode with the Sleep Mode

fU The setting temperature will be raised by 1°C 30 minutes later and by 2°C 1 hour later.

fU The operation will be stopped after 1, 2, 3, 4, 5, 6, 7 hours.

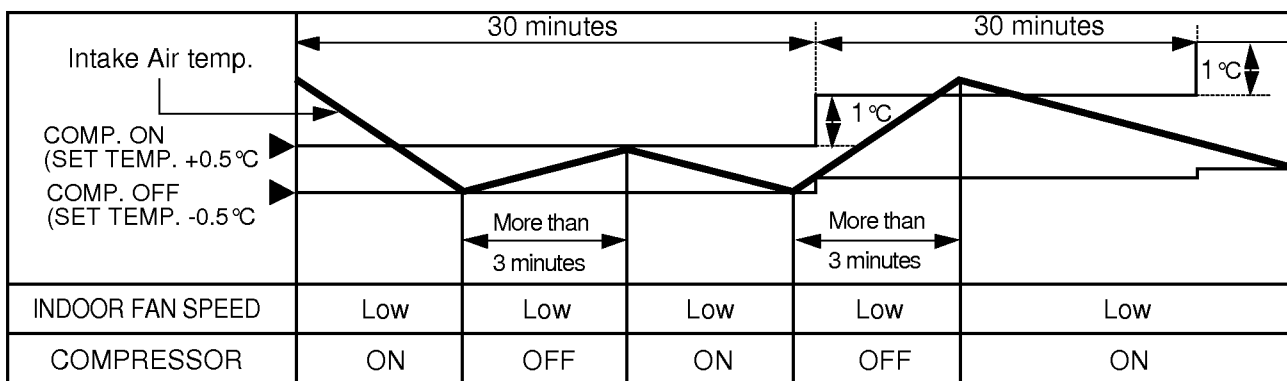

• Heating Mode with the Sleep Mode.

fU The operation will be stopped after 1, 2, 3, 4, 5, 6, 7 hours.

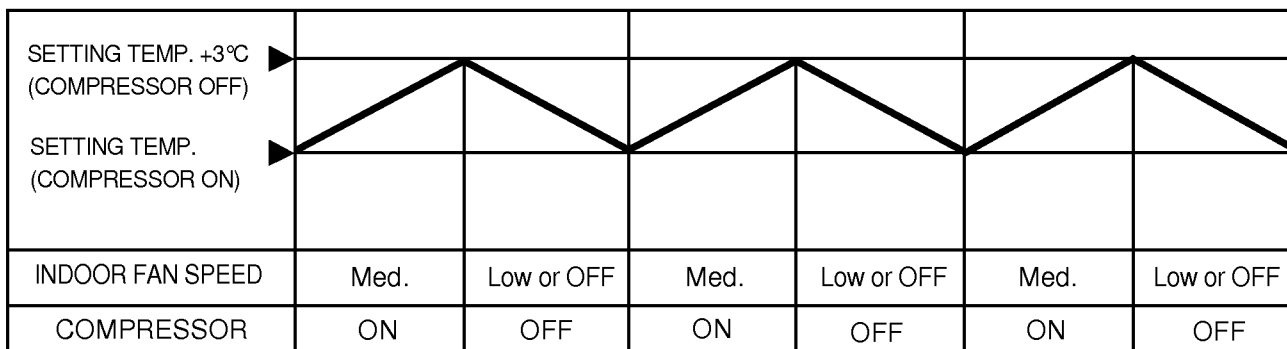

5. Auto Operation

- The operation procedure is as following.

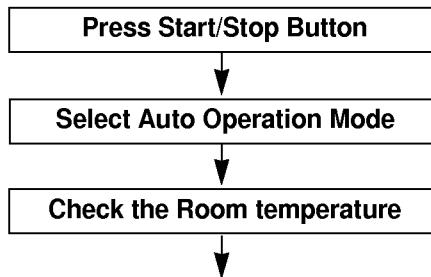

Operation mode Indoor fan speed Setting temperature	are automatically decided by Fuzzy rule.		
Intake-air temperature	below 21 °C	Over 21 °C ~ below 24 °C	Over 24 °C
Operation Mode	Heating	Soft Dry	Cooling

* If initial mode is decided, that mode is continued despite of the room temperature changing.

§ Fuzzy Operation for Cooling

Operation Condition	Intake-air Temperature	Setting Temperature	Fan Speed	Air DirectionControl
When Auto Operation initial start	Over 26 °C	25 °C	Controlled by Fuzzy logic	1/f rhythm
	Over 24 °C~below 26 °C	Intake air -1 °C		
	Over 22 °C~below 24 °C	Intake air -0.5 °C		
	Over 20 °C~below 22 °C	Intake air temperature		
	below 20 °C	20 °C		
When Switch to Auto Operation	Over 20 °C~below 30 °C	Fuzzy control		
	below 20 °C	20 °C		
	over 30 °C	30 °C		

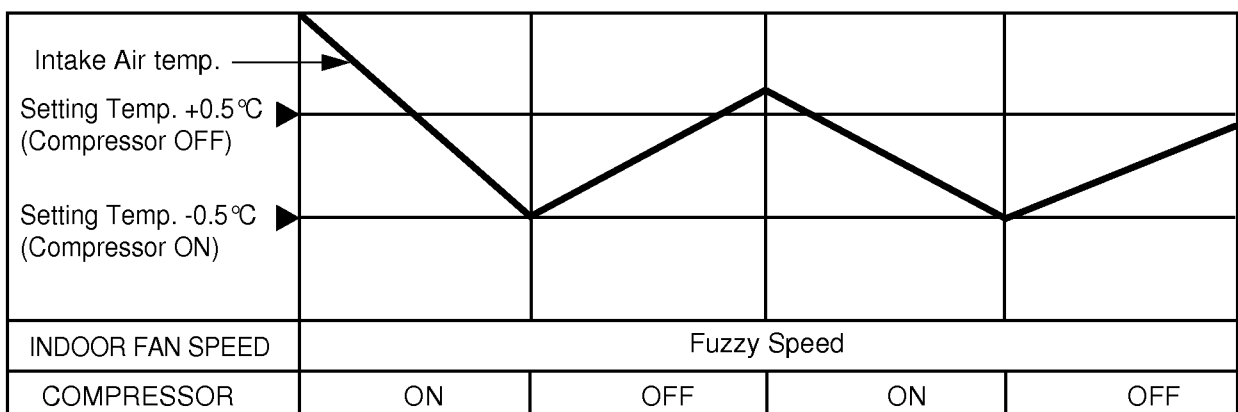

■ **Auto Operation for Soft Dry**

The Setting temperature will be set to the same that of the current intake-air temperature.

- Compressor ON temperature; Setting temperature +1 °C
- Compressor OFF temperature; Setting temperature -0.5 °C

■ **Auto Operation for Heating**

Intake Air temp.	below 20 °C	Over 20 °C~below 21 °C
Setting temp.	20 °C	Intake air temperature +0.5 °C

6. Heating Mode Operation

The unit will operate according to the setting by the remote controller and the operation diagram is shown as following.

For 7K, 9K, 12K Models

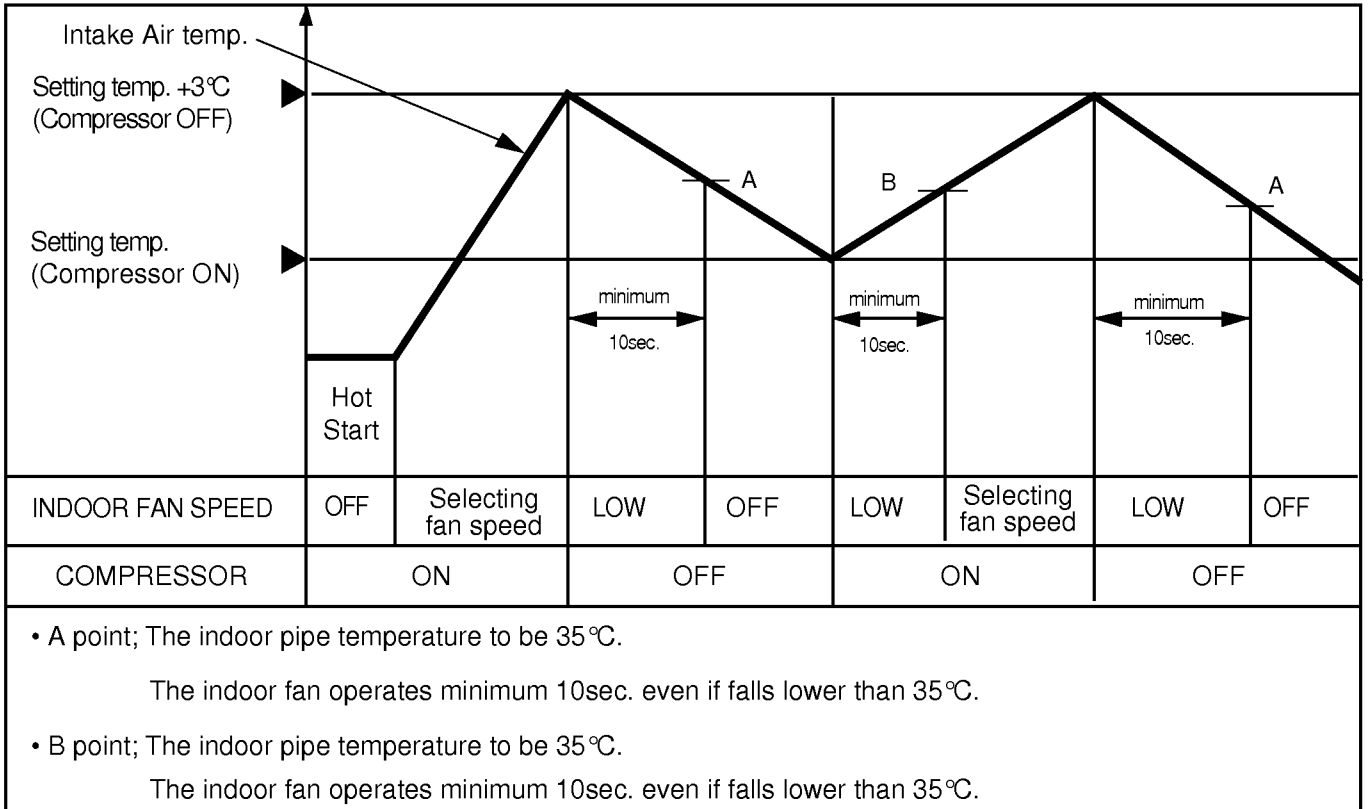

7. Hot-Start Control

- The indoor fan stops until the evaporator piping temperature will be reached at 28°C. (BY TEMPERATURE)
- The operation diagram is as following.

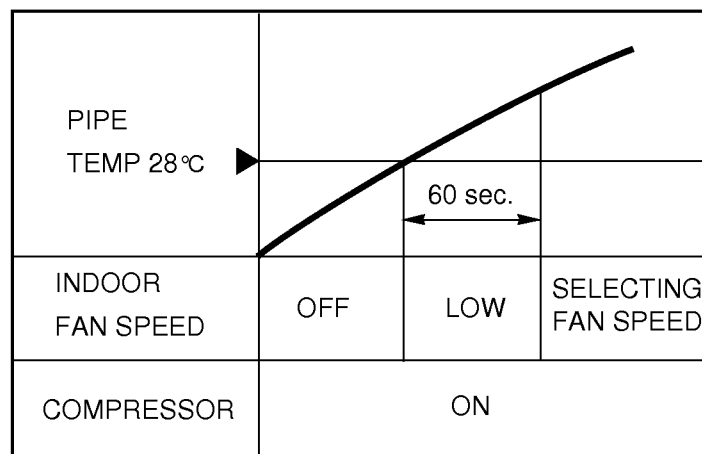

HOT-START BY TEMPERATURE

8. Deice Control

- fU Deicing operation is controlled by timer and sensing the indoor pipe temperature.
- fU Deicing operation checks the indoor pipe temperature and Intake-air temperature at 25 minutes and 60 minutes on starting of heating operation, and discriminates by temperature difference.
- fU When the heating operation passed 25 minutes, the temperature ($T_1 = TE1 - TR1$) is checked and memorized with checking the indoor pipe temperature (TE1) and the indoor Intake-air temperature (TR1).
- fU When the heating operation passed 60 minutes, deicing operation checks the indoor pipe temperature (TE2) and the indoor Intake-air temperature (TR2), and checks indoor pipe temperature (TE2), the temperature difference ($T_2 = TE2 - TR2$) and the temperature difference $T_d (= T_1 - T_2)$ of T_1 , T_2 .
If temperature of indoor pipe is below 32°C Deicing function operates at the priority I condition.
If temperature of indoor pipe is over 32°C Deicing function operates at the priority II condition.
If the temperature difference (T_d) become more than the option temperature, deicing operation starts.
- fU At that time, deicing operation time is decided.
- fU The deicing operation time starts after deicing operation started.
- fU If deicing operation start, above heating operation time is reset, so if deicing operation is finished, the heating operation time is recounted.
- fU The deicing time and the operation diagram are as following.

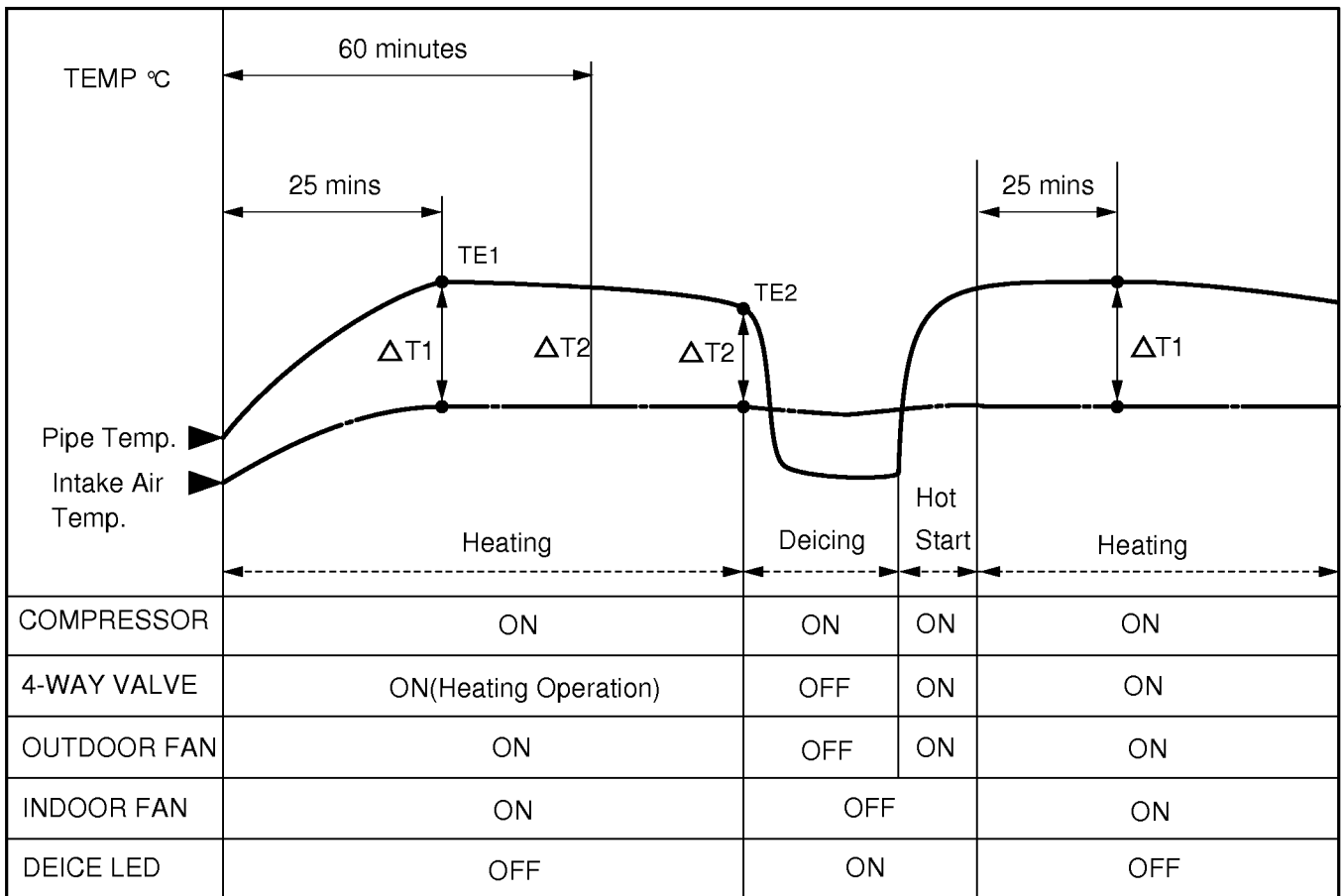

(DEICING DIAGRAM)

Priority I

TE2	below 30°C	30~31°C	31~32°C	Over 32°C
Deicing Time	12mins	11mins	10mins	Heating Operation

Priority II

$SET1 - SET2 = SETd$	Over 3.5°C	3.0 ; 3.5°C	2.5 ; 3.0°C	2.0 ; 2.5°C	below 2.0°C
Deicing Time	12mins	11mins	10mins	9mins	Heating Operation

9. Soft Dry Operation.

- During Soft Dry Operation, the compressor ON temperature is the setting temperature plus 1 °C, the compressor OFF temperature is the setting temperature minus 0.5 °C.
- When the room temperature rises over the compressor ON temperature, the operation mode is switched to the cooling mode.
- When the room temperature falls between the compressor ON temperature and OFF temperature, the operation mode is switched to the Soft Dry Operation.

In this temperature range, 10min. Dry operation, 5.5min operation OFF, 1.5min. only fan operation repeat. During 10min Dry operation, even if the room temperature falls below compressor OFF temperature, 10min(MAX) Compressor ON from starting of Dry operation which includes 4 min. Compressor ON operation below the compressor OFF temperature.

- In micom dehumidify mode, control of fan speed is as following.

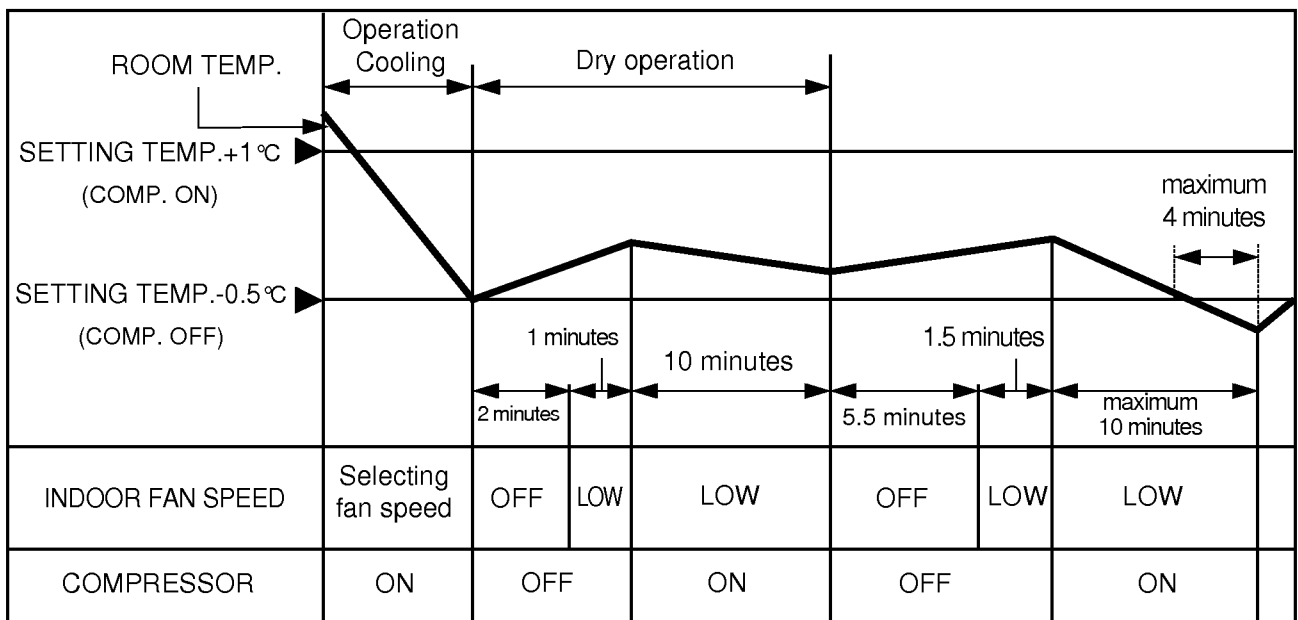

10. Forced operation

- If you lose wireless remote controller, you can operate the unit with forced operation switch.
- The standard conditions are as following.

	Cooling Model	Heat pump Model		
		Room Temp > 24°C	21°C > Room Temp > 24°C	Room Temp < 21°C
Operation Mode	Cooling	Cooling	Soft Dry	Heating
Indoor Fan Speed	High	High	Low	High
Setting Temp.	22°C	22°C	Room Temp.	24°C

Operation

(1) Name and Function-Remote Control

1) Cooling Model

Remote Controller

Signal transmitter

Transmits the signals to the room air conditioner.

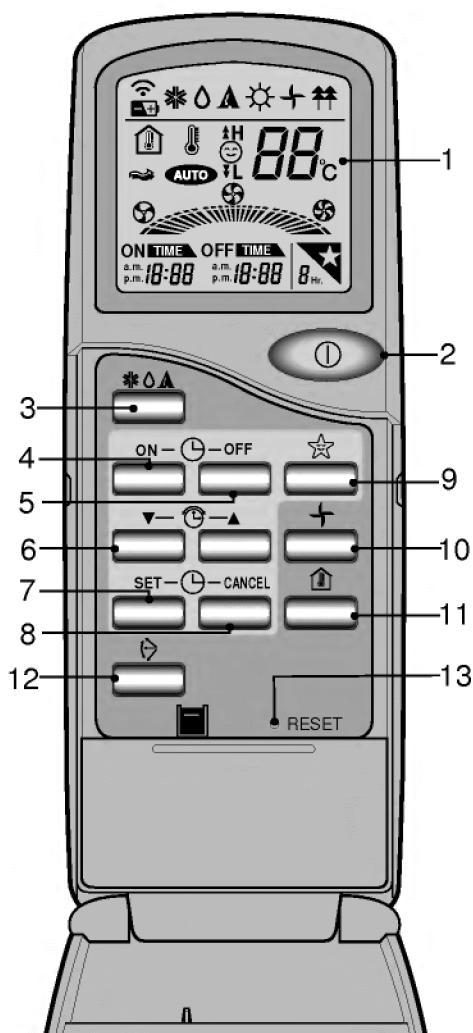

↙A **Operation display**

Displays the operation conditions.

↙B **Start/Stop Button**

Operation starts when this button is pressed, and stops when the button is pressed again.

↙C **Operation Mode Selection Button**

Used to select the operation mode.

- Cooling Operation Mode.
- Soft Dry Operation Mode.
- Auto Operation Mode.

↙D **ON Timer Button**

Used to set the time of starting operation.

↙E **OFF Timer Button**

Used to set the time of stopping operation.

↙F **Time Setting Button**

Used to adjust the time.

↙G **Timer Set Button**

Used to set the timer when the desired time is obtained.

↙H **Timer CANCEL Button**

Used to cancel the timer operation.

↙I **Sleep Mode Auto Button**

Used to set Sleep Mode Auto Operation.

↙J **Fan Operation Button**

Used to circulate room air without cooling.

↙K **Room Temperature Checking Button**

Used to check the room temperature.

↙L **Vertical Airflow Direction Control Button**

Used to set the desired vertical airflow direction.

↙M **Reset Button**

2) Heating Model

Remote Controller

Signal transmitter

Transmits the signals to the room air conditioner.

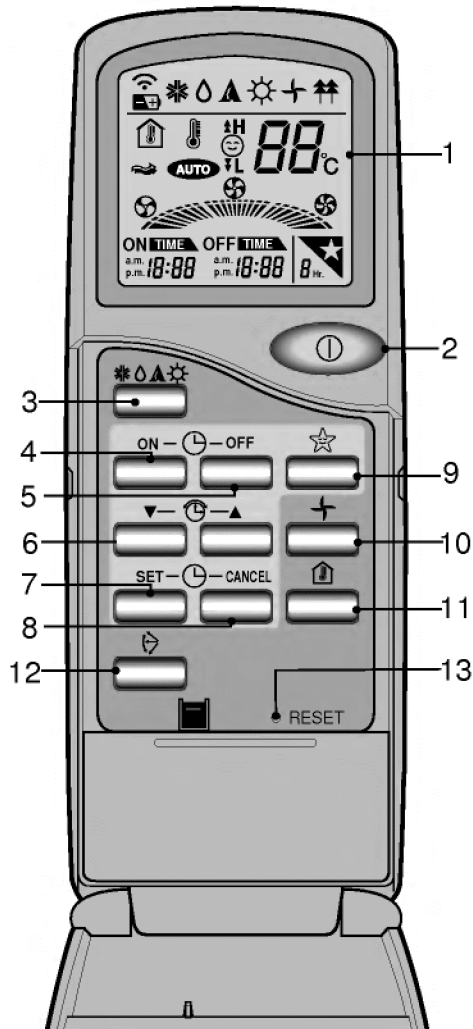

↙A **Operation display**

Displays the operation conditions.

↙B **Start/Stop Button**

Operation starts when this button is pressed, and stops when the button is pressed again.

↙C **Operation Mode Selection Button**

Used to select the operation mode.

- Cooling Operation Mode.
- Soft Dry Operation Mode.
- Auto Operation Mode.
- Heating Operation Mode.

↙D **ON Timer Button**

Used to set the time of starting operation.

↙E **OFF Timer Button**

Used to set the time of stopping operation.

↙F **Time Setting Button**

Used to adjust the time.

↙G **Timer Set Button**

Used to set the timer when the desired time is obtained.

↙H **Timer CANCEL Button**

Used to cancel the timer operation.

↙I **Sleep Mode Auto Button**

Used to set Sleep Mode Auto Operation.

↙J **Fan Operation Button**

Used to circulate room air without heating.

↙K **Room Temperature Checking Button**

Used to check the room temperature.

↙L **Vertical Airflow Direction Control Button**

Used to set the desired vertical airflow direction.

↙M **Reset Button**