

White-Rodgers
P.O. Box 6977
9797 Reavis Road
St. Louis, Missouri 63123

10C17E - 41000 ELECTRONIC AIR CLEANER

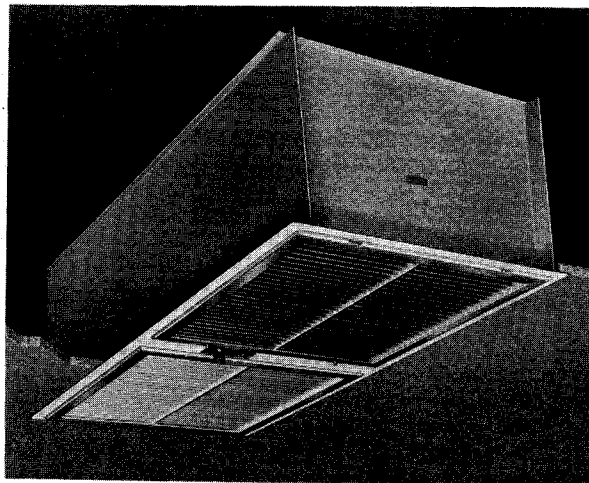

OPERATION AND INSTALLATION MANUAL

TABLE OF CONTENTS

Subject	Page	Subject	Page
I. INTRODUCTION		IV. MAINTENANCE/WASHING	
A. How Your Air Cleaner Works.....	2	A. Washing Cell	6
B. Specifications	3	B. Ionizing Wire Replacement	6
C. Efficiency	3	C. Ozone.....	6
D. Warnings	3	V. ELECTRICAL	
II. GENERAL INFORMATION		A. Electrical Troubles and Corrections	7
A. Unpacking.....	3	B. Power Supply Replacement.....	8
B. Application	3	VI. ELECTRICAL TROUBLESHOOTING	
C. Energy Saving	3	9	
D. Sizing	3	VII. REPLACEMENT PARTS	
III. INSTALLATION		A. Exploded View	10
A. Placement	5	B. Parts List	11
B. Ceiling Mounting	5	C. Ordering Information.....	11
C. Electrical Wiring	5		

SPECIFICATIONS

NAME: Emerson Self-Contained Flush-Mount Electronic Air Cleaner

MODEL: 10C17E-41000

VOLTAGE AND FREQUENCY: 120 Volt, Nominal, 60 Cycle AC

DIMENSIONS: 47 $\frac{3}{4}$ "x23 $\frac{3}{4}$ "x15"

TOTAL AMP DRAW: 2.2 Amps

VARIABLE SPEED: 200 To 1000 cfm

I. INTRODUCTION

A. HOW YOUR AIR CLEANER WORKS

In Bars, Restaurants, Conference Rooms, etc., millions of air-borne particles are continually being circulated by heating/cooling systems and other types of activity. An Air Cleaner removes the smoke, dust, dirt and pollen particles with an electrostatic process that works this way:

1. The enclosed fan circulates the air up through the bottom of the Electrostatic Air Cleaner and out through the outlet grille.
2. The Ionizing Section contains many fine ionizing wires which charge the incoming air-borne particles.

3. The charged particles move along through the Collector Section and are collected on the collector plates and trapped there (just like a magnet attracts and collects iron filings).
4. The cleaned air is then drawn through a charcoal filter to assist in removal of unpleasant odors.
5. The cleaned and purified air is now discharged to recirculate through your establishment.

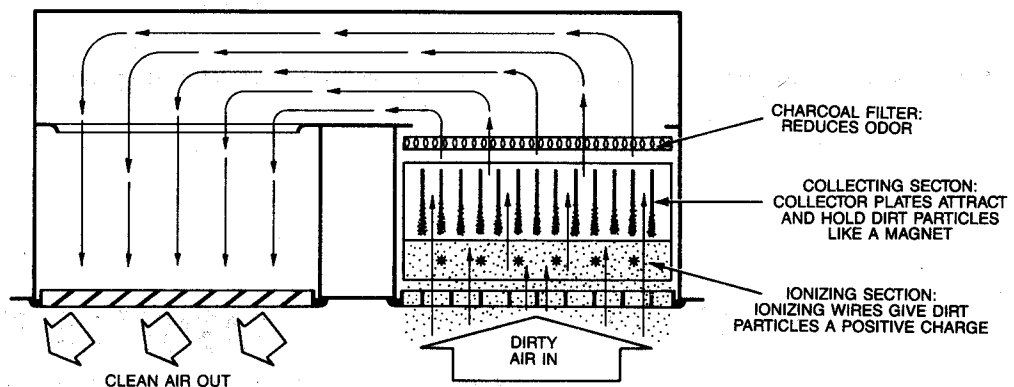

FIG. 1 Pictorial Illustration of Air Cleaning Process

B. SPECIFICATIONS

The Air Cleaner takes its energy saving power requirements (approx. 154 watts) from standard electrical wiring systems. No special provisions are required. Local residential and commercial wiring codes apply.

CURRENT AND POWER CONSUMPTIONS

VOLTAGE: 120AC-60HZ

AMPS: Hi-Speed 2.5

WATTS: Hi-Speed 240

FAN SPEED: Variable 200 to 1000 CFM

D.C. OUTPUT VOLTAGE+OUTPUT TO GROUND:
6400 VDC \pm 250V (Cell Connected)

WEIGHT: 78 lbs.

SHIPPING WEIGHT: 86 lbs. (42kg)

C. EFFICIENCY

Efficiency varies with fan speed approximately 90% at low speed and 65% at high speed.

Efficiency ratings are based on American Society of Heating, Refrigerating and Air Conditioning (ASHRAE) Standard 52-76 Atmospheric Dust Spot Method.

D. WARNING

WARNING: Electronic Air Cleaners **CANNOT** be used in any areas where combustible gases or vapors are likely to be present in the air.

II. GENERAL INFORMATION

A. UNPACKING

All components of the Air Cleaner are packed in one box. Carefully inspect the outside of the box for damage that may indicate damaged parts inside.

Use care when removing the electronic cell to avoid possible damage to the collector plates, check for broken ion wires and bent collector plates. (See Section IV).

Because it provides its own air circulation, the Air Cleaner can be used in most applications requiring the removal of airborne particles from an enclosed space.

B. APPLICATION

This Model is designed for commercial and light industrial applications in enclosed areas where it is not practical to have central air cleaning or where central systems are overloaded. Common applications are cigar and cigarette smoke removal for the air in Bars, Restaurants, Bowling Alleys, Waiting and Meeting Rooms, Stores, Schools, and Churches. Light Industrial Shops: Printing, Computer Rooms, Clean Rooms, etc. As a bonus, the Electronic Air Cleaner also traps dust, dirt, soot, pollen and many other airborne pollutants including bacteria.

When used in light industrial applications, the electronic cell must be cleaned more often. Depending on the dirt load, cleaning may vary from 1 day to 2 weeks.

Bowling alleys with air contamination consisting mostly of tobacco smoke will typically require one unit for every 6 or 7 alleys requiring cleaning every 2 to 4 weeks.

C. ENERGY SAVING

One of the benefits to be expected from the use of the Electronic Air Cleaner is a reduction in the amount of outdoor air brought into the building. Typically, the use of outdoor air, at rates up to 20 air changes per hours, is recommended to replenish oxygen and to dilute and remove airborne contamination, particularly smoke.

This air cleaner helps to provide this clean recirculated air by removing particulate contamination (visible smoke). The reduction in outdoor air used of course, means a reduction in the amount of heating or cooling required. This reduces operating cost and equipment wear.

The ASHRAE Standard 62-81, Natural and Mechanical Ventilation, gives recommended quantities of ventilation air terms of 100 percent outdoor air. These recommended outdoor air quantities may be reduced to 33 percent of the specified quantities if air cleaning is provided. If adequate odor and gas removal equipment is also used, the recommended outdoor air quantity may be further reduced to 15 percent of the specified quantities. However, the standard recommends that "in no case shall the outdoor air quantity be less than 5 cfm (.2m³ min.) per person." The standard recommended 30 to 40 cfm (about 1m³) ventilation air per person where people are smoking, such as in a cocktail lounge. This is to ensure adequate oxygen replenishment.

D. SIZING

The correct number of Electronic Air Cleaners required for a particular application depends upon:

- **Type of contamination**
- **Number of occupants**
- **Volume of the room**
- **Use of the room**
- **Outdoor air quality**

The sizing information was generated using the ASHRAE Handbook of Fundamentals, 1985; the ASHRAE Guide and DATA Book, Application, 1982; and ASHRAE Standard 62-81, Natural and Mechanical Ventilation.

It simplifies the sizing procedure for most applications. Use this information as a guide. You are encouraged to use your experience and judgement in the application of this data, keeping in mind local codes and minimum air requirements.

SIZING CHART FOR YOUR AIR CLEANER

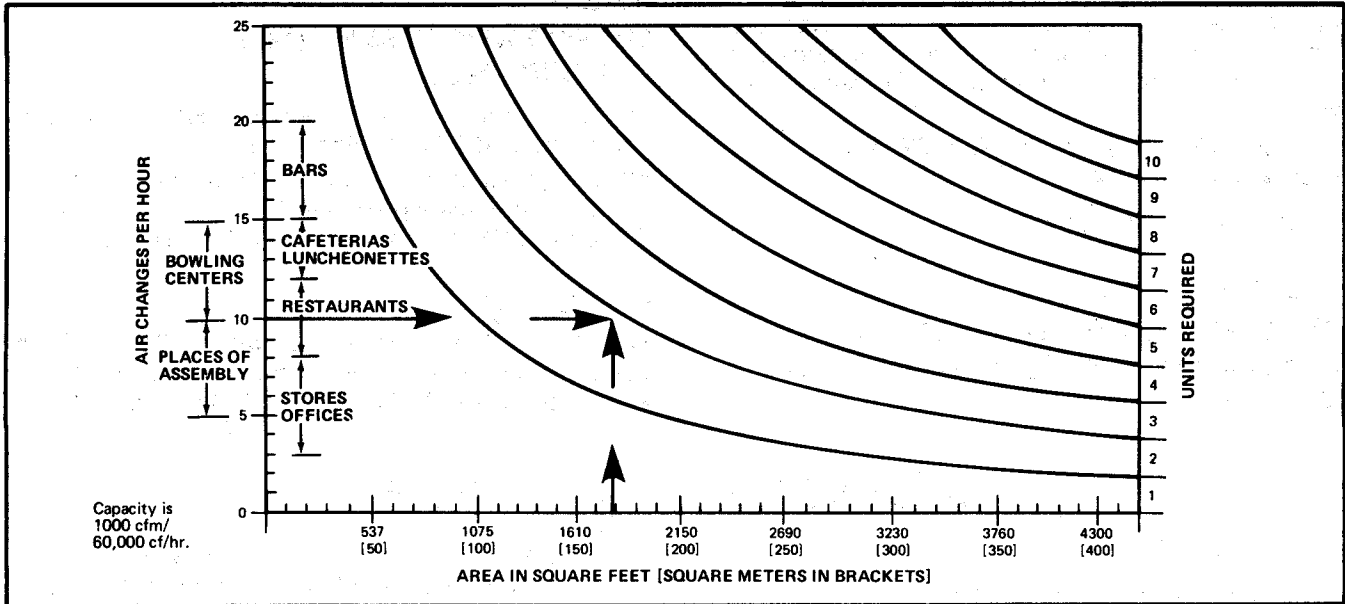

The number of air changes per hour determines the amount of air cleaning obtained. More air changes per hour than recommended in the graph above are unnecessary as the ASHRAE data for which it was constructed is conservative. Fewer air changes per

hour than recommended in the graph may mean allowing the entrance of more outdoor air to maintain acceptably low contaminant levels, or tolerating a partially cleaned atmosphere, which may be acceptable to some users.

EXAMPLE 1 - SIZING BY AIR CHANGES PER HOUR AND ROOM AREA.

Using the graph:

1. Extend a horizontal line from the desired number of air changes per hour, until it intersects with . . .
2. A vertical line drawn upward from the area of the room.
3. The intersection point indicates the number of units required.

A restaurant has a 40 x 45 foot (12 x 14 meter) dining room. How many air cleaner units would be installed?

Solution:

1. Find floor area. 40 ft. x 45 ft. = 1800 sq. ft. (12m x 14m = 168 sq. m). Assuming that 10 air changes per hour would be adequate and an 1800 sq. ft. (168 sq. m) area, the graph indicates a requirement for two (2) units.

EXAMPLE 2 - SIZING BY AIR CHANGES PER HOUR AND ROOM VOLUME.

Restaurant proprietor wants to use electronic air cleaning to remove cigarette and cigar smoke from the air. The dining area is 25 x 40 feet (8 x 12 meters) with a 15 ft. (4.5m) ceiling. How many air cleaners will be required on this job?

Solution:

1. Calculate volume of room, 25 ft. x 40 ft. x 15 ft. + 15000 cu. ft. (8m x 12m x 4.5m + 432m³).

2. Determine volume of air to be circulated each hour. 10 air changes per hour is used on the assumption that the intent is to substantially reduce, but not necessarily to completely eliminate smoke.

$$15,000 \text{ cu. ft.} \times 10 \text{ air changes per hour} = 150,000 \text{ cu. ft./hr.}$$

$$\frac{150,000 \text{ cu. ft./hr.}}{60 \text{ min./hr.}} = 2500 \text{ cu. ft./min.}$$

$$(432\text{m}^3 \times 10 \text{ air changes per hr.} = 4320\text{m}^3/\text{hr.})$$

$$\frac{4320\text{m}^3/\text{hr.}}{60 \text{ min./hr.}} = 72\text{m}^3/\text{min.}$$

3. Determine number of air cleaners required.

$$\frac{\text{Desired Circulation}}{\text{Air Cleaner Capacity}} = \text{units required}$$

EXAMPLE 3 - SIZING BY OCCUPANT LOAD

A cocktail lounge averages 75 occupants. Using the ASHRAE recommended minimum of 35 cfm (1m³/min. per person).

$$\frac{2500 (72)}{1000 (30)} = (2 \text{ or } 3 \text{ units})$$

Solution:

75 people x 35 cfm (1m³/min.) per person = 2625 cfm (75m³/min.)

$$\frac{2625 (75)}{1000 (29)} = 2.6 (2 \text{ or } 3 \text{ units})$$

III. INSTALLATION

A. PLACEMENT

The installer must be qualified to make approved electrical connections and a safe ceiling installation with attention to the best placement as shown in the following drawings.

The electronic Air Cleaner should be mounted in the ceiling grid $\frac{1}{3}$ of the room length away from the wall. Air is drawn thru the straight vaned grille and discharged thru the angled grille which should be directed toward the remaining $\frac{2}{3}$ of the room. Divide larger rooms into sections and use a unit in each section (see Fig. 3).

Check Existing air circulation in the room. The Air Cleaner should be installed so that it aids the circulation already established. When air flow patterns are not immediately apparent, observe the smoke from a cigarette in various locations within the room. Do not locate near a heating or air conditioning intake or exhaust vent if it interferes with the air flow discharge and return air to the unit.

B. CEILING MOUNTING

The Air Cleaner is mounted by suspending it from the building structure above the suspended ceiling. The mounting holes in the unit are $\frac{3}{8}$ " diameter and are located at the four upper corners. (Fig. 2).

Mounting Detail

Be sure to select the mounting location so that the structure above is sufficiently strong to support the unit (78 lbs.). Four holes are located at the corners for suspension wires as shown in Figure 4. CAUTION: Do not allow the unit to be supported by the ceiling grid system.

C. ELECTRICAL WIRING

Standard electrical wiring of 120 volts, 60 Hz., 15 AMP circuit is required. Local residential and commercial wiring codes shall apply. Flexible conduit should be used. See Figure 5.

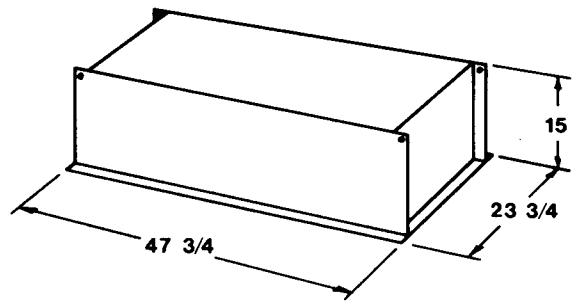

FIG. 2 - Approximate Installation Dimensions in inches.

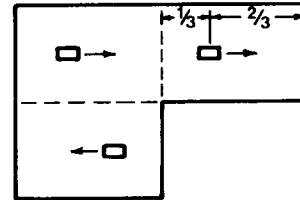

FIG. 3 - Mount the unit the ceiling at the center of area to be cleaned.

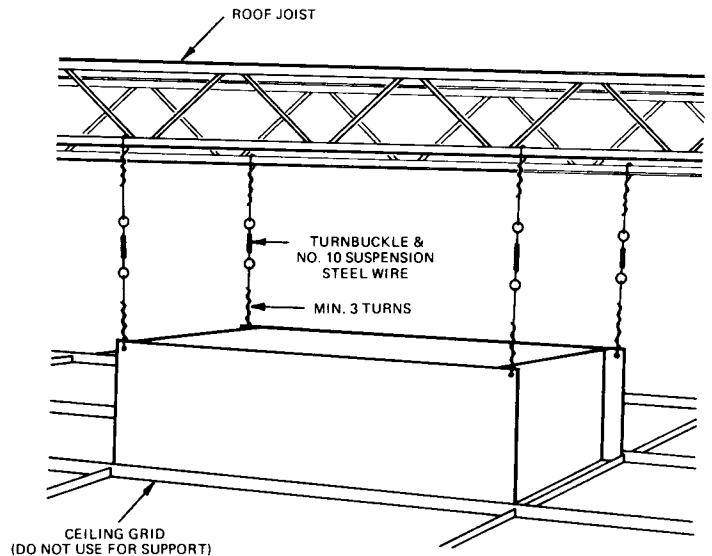
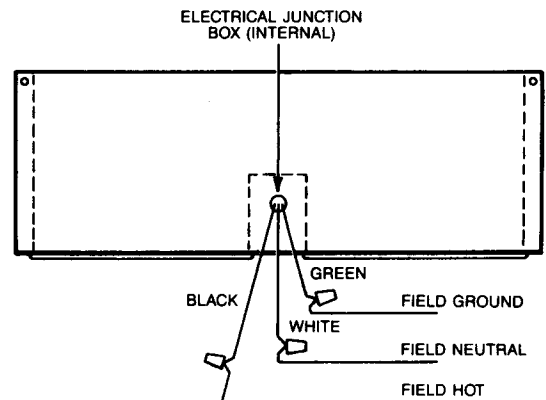

Fig. 4



IV. MAINTENANCE/WASHING

A. WASHING CELL

When to Wash: Periodically the dirt collected by your unit must be removed. The frequency of washing will depend on the amount of dirt present in the air in your locality.

Frequent washings are in no way harmful to your unit, but prolonged use without cleaning will decrease its dirt collecting ability.

The washing frequency best suited for your unit can be determined by examining the dirt collecting components at three week intervals. As the dirt begins to collect, you will notice a light film, then a very definite collection will be evident at a later examination. When there is a noticeable build-up of dirt, it is time to wash.

The washing schedule could, therefore, be to wash the collecting cell every three to eight weeks; or more often if in areas of heavy contamination..

STEPS FOR WASHING:

1. Turn control switch "off".
2. Turn thumb screws to release grille and swing down. Push aside latches and swing down cell and lift out. Depress the spring latch and remove the charcoal filter. Close the Grille. Note: Do not wash the charcoal filter.
3. To facilitate washing, place the cell in automatic dishwasher, stationary tub, shower stall or over floor drain. Use hot soapy water and rinse thoroughly. As an aid to drying, rinse with clear hot water. Allow cell to dry thoroughly (2 hrs. min.).

NOTE: ionizing wires may become coated with dust of other foreign matter, causing loss of cleaning ability by the collecting cell. Using a damp cloth, wipe each ionizing wire clean, exercising care not to damage them. This should be done each time the cell is cleaned.

4. Open the grille and replace charcoal filter.
5. Hook the slotted tabs of cell on hooks in cabinet and swing up into place. Push the latches back in place to retain the cell.
6. Close the grille securely fastening the thumb screws.
7. Turn control switch "on".
8. If arcing noise occurs due to wet cell, turn control switch "off" and allow more drying time.

B. IONIZING WIRE REPLACEMENT

The fine tungsten ionizing wire in the charging section of the electronic cell may break or become damaged. Inspect the cell from the upstream side after washing to make sure that none of the wires are broken or out of position. During operation, a broken or deformed wire generally causes a short to ground, possibly with visible arcing or sparking. This condition, or any other short in the ionizing section of the cell, will cause the indicator light to go out.

Broken wires must be replaced as soon as possible. Remove all parts of the broken wire. If necessary, the cell may be temporarily used with one wire missing. See PARTS LIST for part number of the replacement wire. Wires come cut to length with round loops at each end for easy installation in the electronic cell.

See Fig. 7 how to replace ionizing wires on the cell.

1. Use care to avoid damage to the spring connector or other parts of the cell during the installation.
2. Hook one end of the ionizing wire over the spring connector at one end of the cell.
3. Hold the opposite eyelet with a needlenose pliers and stretch the wire in length of the cell. Depress the opposite spring connector and hook the eyelet over it.

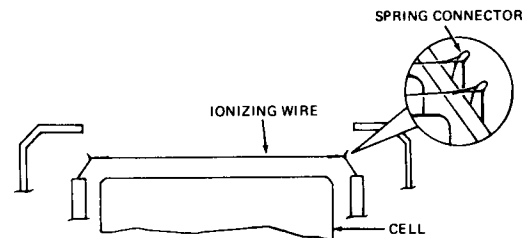

FIG. 7

C. OZONE

Under normal operating conditions, all electronic air cleaners produce minute quantities of ozone. The design of the unit has been tested and is far below the published permissible limits. The level of detection (when it is noticed), varies from individual to individual, some being more susceptible than others.

Usually a new unit will produce more ozone than one that has been in operation for several weeks. This is due to the normal amount of sharp corners or manufacturing burrs on the ionizing collecting cell causing points of voltage concentrations on which in turn produce ozone. The voltage working on these areas however, tends to round them off, thereby they are self-correcting.

An ionizing-collecting cell that has been damaged, where in the designed spacing between electrically charged and ground components has been decreased, may also produce an abnormal amount of ozone.

CHECK LIST FOR ABOVE:

Check for:

1. Damaged (bent) plates - Straighten or replace.
2. Loose ionizing wires - Repair or replace.
3. Dirty Cell - Clean.

V. ELECTRICAL - CAUTION!!!!

WARNING: Do not attempt to install this air cleaner unless you are completely familiar with the necessary tools, equipment, utility connections and potential hazards involved. We ask that you contact a reliable heating and air conditioning dealer or other qualified installer to install this unit.

A. ELECTRICAL TROUBLES & THEIR CORRECTIONS

1. When the circuit has been de-energized always discharge any residual current in the secondary with an insulated handle screwdriver.
2. Always ground power supply and ionizing-collecting cell when bench testing.

POWER SUPPLY: If there is primary power to the power supply and the output voltage is absent or low, the power supply is defective. A check can be made by using a high voltage probe between common ground, (power pack housing) and the hi-voltage output terminal. A good power supply will produce a pronounced arc where a defective one will produce no arc at all or a very weak one. (Refer to Fig. 8, Troubleshooting Ref. Chart).

PRIMARY CIRCUIT: If there is supply line voltage at the service connections and no input voltage to the power supply, the outage can be located by checking operation of the safety switch and control switch as well as the interconnecting wiring, with a 120 volt test light.

IONIZING-COLLECTING CELL: The cell is electrically energized through a contact terminal located at the top center of the cell. The ionizing wires and every other collector plate are electrically charged while each alternate plate is grounded.

If the space between the charged and ground components is bridged with conductive or semiconductive material, a short circuit develops. The bridging or short may be caused by broken components or foreign material lodged between or on the components.

Most troubles in the cell can be readily detected visually.

CAUSES

CORRECTIONS

- | | |
|---|---|
| <ol style="list-style-type: none"> 1. Excessive dirt build-up..... 2. Large pieces of foreign matter lodged between plates 3. Very dirty insulators 4. Broken ionizing wires..... 5. Excessively bent or misaligned components due to mishandling..... 6. Externally broken or cracked insulators..... 7. Internally defective insulators..... | <ol style="list-style-type: none"> Wash Remove Clean Remove all pieces of broken wires & replace Straighten/ Replace Replace Replace |
|---|---|

ARCING NOISE: When an arcing noise is noted, it is usually located in the DC high voltage circuit. The ionizing-collecting cell is part of this circuit and normally the trouble will be found to be in the cell. The noise is caused by the high voltage arcing to ground.

An occasional arcing noise is normal and inherent in all electronic air cleaners. These occasional arcs are caused by large particles of dirt in the air such as a cigarette ash, insect, etc. Constant or repeated intermittent arcing can be an indication of an excessively dirty cell or damage as noted above.

HISSING NOISE: A hissing noise (or frying) usually stems from a loose high voltage component leaking to the ground. The reduction in the designed spacing usually is caused by bends or deformities in the cell from mishandling.

Check List for Arcing and Hissing Noise:

(X) Arcing (O) Hissing

- X Loose Ionizing Wire(s) - Repair or replace.
- X Excessively dirty cell components - Clean.
- X Damaged (bent) plates of ionizer - Straighten or replace.
- X Defective or loose voltage lead or contact assembly - Repair or replace.
- Improper ground - Check ground and correct if necessary.
- X Cracked insulator - Replace.
- X Poor connection between cell and contact assembly - Repair.

- X **Coated Ionizing Wires**

QUICK REFERENCE TROUBLE CHART

CONDITION OR SYMPTON	TROUBLE DESCRIPTION	PROBABLE LOCATION	PROBABILITY	POSSIBLE CAUSE	CORRECTION
Indicating Light Out	Short Circuit	Cell	Good	Broken Ion Wire Excessive Dirt Object Between Plates Damaged (Bent) Plates Damaged (Bent) Ionizer Broken Insulator	Remove & Replace Wash Remove Straighten or Replace Straighten or Replace Replace
Indicating Light Out	Short Circuit	Power Supply	Fair	Defective Power Supply	Replace
Indicating Light Out	Light Out But Unit Working	Indicating Light	Remote	Defective Light	Replace
Indicating Light Out	Open Circuit	Primary Wiring	Fair	No Power at Service Connection Access Panel not Closed Bad (Open) Interlock Sw. Bad (Open) On/Off Switch Power Supply Loose Wiring	Obtain Power Close Replace Replace Replace Repair
Cracking Noise & Flickering Indicating Light	Objectionable Noise	Cell	Occasional	Loose Ionizing Wire Dirty Cell Damaged (Bent) Plates Damaged (Bent) Ionizer	Replace Wash Straighten or Replace Straighten or Replace
Loud Hissing Noise	Same	Cell Hi-Voltage Connection	Occasional	Dirty Cell Loose Hi-Voltage Connection	Wash Correct
Radio and/or TV Interference	Same	Cell Hi-Voltage Connection	Not Often	Arcing Improper Ground Loose Hi-Voltage Connection	Wash Cell Correct Correct

FIG. 8

B. Power Supply Replacement

1. Disconnect incoming power to the unit.
2. Remove the screws securing the exhaust grille and let it hinge down. Turn the thumb screws and hinge down the intake grille.
3. Remove the collecting cell and carefully set it aside.
4. The power supply is accessible thru the access cover on the exhaust grille side.
5. Disconnect all lead wires from the power supply and remove the four screws holding it in place from the cell area side.
6. Replace power supply and reverse procedure to complete installation.

VI. ELECTRICAL TROUBLE SHOOTING

WARNING: Do not attempt to install this air cleaner unless you are completely familiar with the necessary tools, equipment, utility connections and potential hazards involved. We ask that you contact a reliable heating and air conditioning dealer or other qualified installer to install this unit.

1. There are two areas in which the majority of service problems originate.

A. The Ionizing-Collecting Cell

B. The Power Supply

The cell, which is removed from the unit periodically to wash away the collected dirt, is more susceptible to physical damage through handling than the power supply. The cell also contains one component, the ionizing wires, which due to their function, have to be designed with a minimum of structural support and therefore susceptible to some expected breakage.

The power supply, like other electrical items exposed to "high voltage" is susceptible to the usual stresses.

Trouble related to either of these two items is readily shown by the indicating light and can be easily and quickly isolated to one, or to the other, by a simple procedure. Refer to item 3 below.

2. INDICATION OF ELECTRICAL TROUBLE

The indicating light is wired into the circuit so that it will monitor both the primary and secondary circuits. (Electrically, the ionizing-collecting cell is a component in the secondary circuit).

When the unit is in normal state of operation, system fan running, access door in place, control switch in "on" position, and the indicating light goes "out", there is an electrical problem. The problem may be either a shorted secondary or an open primary circuit. Although the failure of the indicating light itself should not be overlooked, this condition is unusual and rather remote. The light is L.E.D. and fairly reliable . . .

3. ISOLATING ELECTRICAL TROUBLE TO MAJOR COMPONENTS

When the unit is in normal state of operation and the indicating light goes "out", the trouble can be readily isolated to the ionizing cell or power pack. Turn the unit "off", remove the ionizing-collecting cell, close the access panel and turn unit "on". If the light remains "off" with the cell removed, the trouble is in the power supply or in the primary circuit to the power supply.

If the light comes "on" with the cell removed, the trouble is in the cell.

NOTE: An extremely dirty cell can also cause the light to go out.

VII. REPLACEMENT PARTS

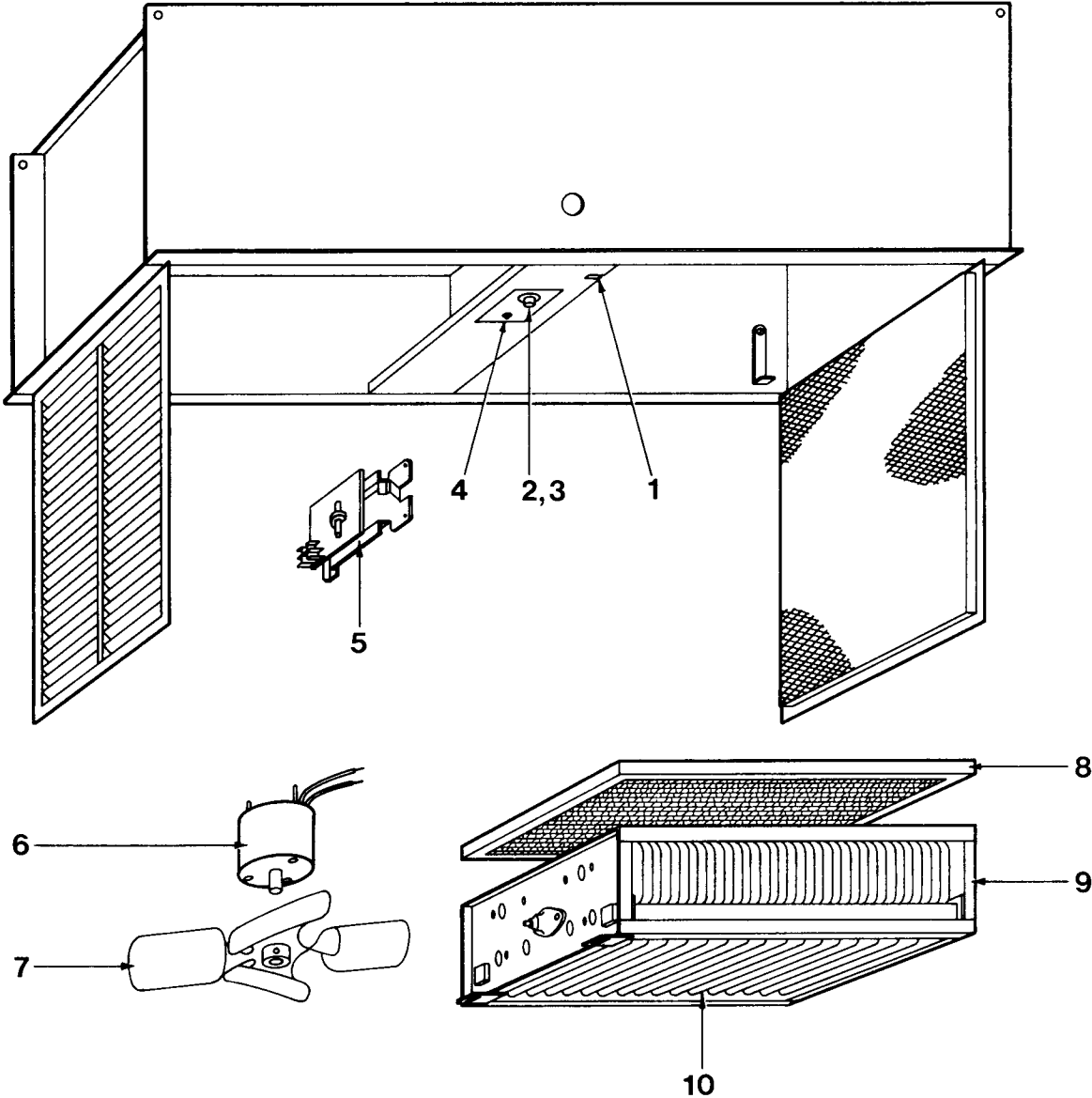

PARTS LIST

for

MODEL 10C17E-41000

ELECTRONIC AIR CLEANER

(FLUSH MOUNT)

KEY NO.	PART NO.	DESCRIPTION
1	F876-0199	Safety Switch
2	F839-0019	Knob
3	F876-0203	Speed Switch
4	F844-0130	Indicator Light
5	F858-1000	Power Supply
6	F849-0060	Fan Motor
7	F848-0368	Fan Blade
8	F825-0497	Charcoal Filter
9	F811-0423	Collecting Cell
10	F843-0500	Ionizing Wire
11	846-0290	Manual (Not Shown)

ORDERING INFORMATION

When purchasing equipment or replacement parts from your Distributor use the Parts List. Always include complete unit model number, part number and description with your parts order.

WHITE-RODGERS SALES DEPARTMENT
P.O. Box 6977
9797 Reavis Road
St. Louis, Missouri 63123
Phone: (314) 577-1476

WARRANTY TO CONSUMER - PURCHASER

EMERSON Electronic Air Cleaners LIMITED WARRANTY

This type White/Rodgers electronic air cleaner is warranted to the consumer against defects in materials and workmanship for 12 months from date of installation. The electronic air cleaner must be installed by a competent heating and/or air-conditioning contractor in accordance with White/Rodgers installation instructions, operated within the unit's listed capacity, and not moved from the original installation site. NO OTHER WARRANTY, WRITTEN OR ORAL, APPLIES. No employee, agent, dealer, or other person is authorized to give any warranty on behalf of White/Rodgers.

If service is required it must be performed by a competent heating and/or air-conditioning contractor (preferably the installing contractor). White/Rodgers liability is limited to replacement of defective parts and does not include the cost of labor, other expenses in servicing the unit, or incidental or consequential damages. SOME STATES DO NOT NOT ALLOW THE EXCLUSION OR LIMITATIONS ON THE LENGTH OF WARRANTY ON INCIDENTAL OR CONSEQUENTIAL DAMAGES, SO THE ABOVE LIMITATIONS OR EXCLUSIONS MAY NOT APPLY TO YOU.

If the installing dealer or contractor fails to render performance under the terms of this Limited Warranty within a reasonable time, then contact in writing:

WHITE-RODGERS Division of Emerson Electric Co., 9797 Reavis Road, St. Louis, MO 63123, (314) 577-1300

The consumer may be asked to return the air cleaner or part (s) claimed to be defective to White-Rodgers, 303 North Industrial Park Rd., Harrison, Arkansas 72601 or nearest distributor point, at the expense of the consumer. The consumer will be expected to supply information on serial number, date of installation, name of installing dealer, and model number of the unit involved.
THIS WARRANTY GIVES YOU SPECIFIC LEGAL RIGHTS, AND YOU MAY ALSO HAVE OTHER RIGHTS WHICH VARY FROM PROVINCE TO PROVINCE.