

This Owner's Manual is provided and hosted by [Appliance Factory Parts](http://ApplianceFactoryParts.com).

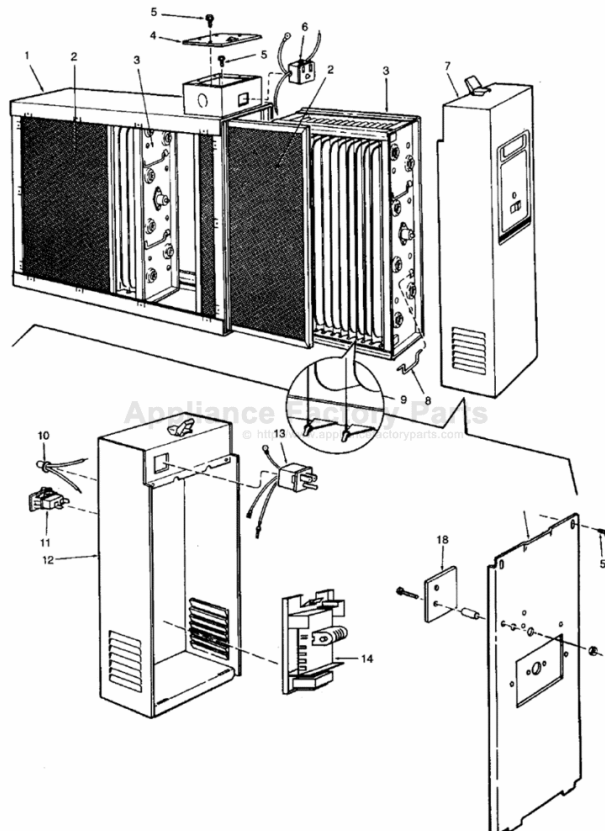

# WHITE RODGERS SST14C26S-010 Owner's Manual

[Shop genuine replacement parts for WHITE RODGERS  
SST14C26S-010](#)



[Find Your WHITE RODGERS Air Cleaner Parts - Select From 61 Models](#)

----- Manual continues below -----

# Electro-air®

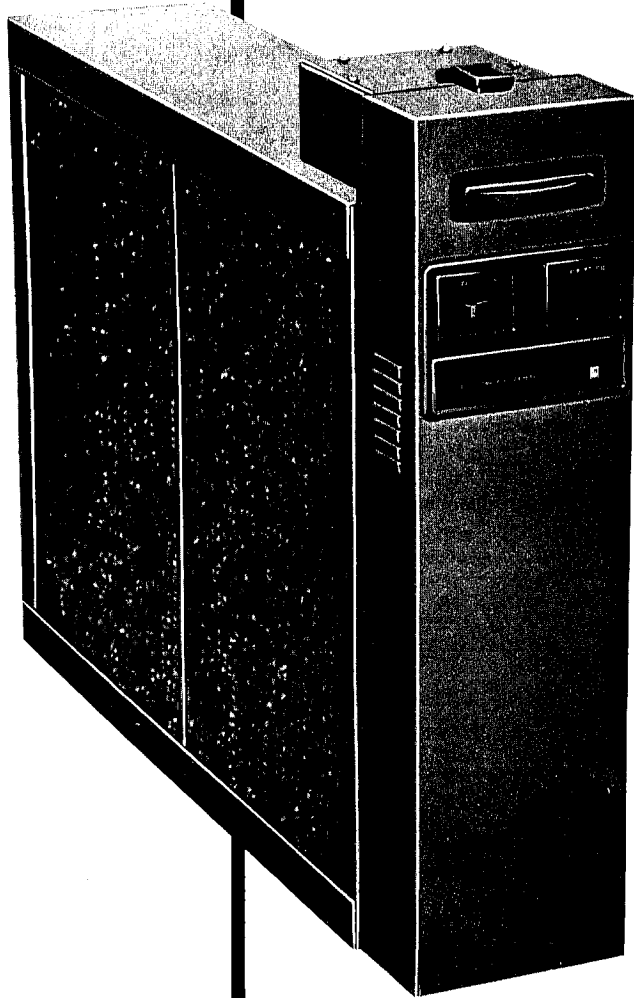

OWNERS MANUAL  
■ INSTALLATION  
■ OPERATION

## **SST ELECTRONIC AIR CLEANER**

MODEL NOS. 10C26S-01000,  
14C26S-01000  
and 20C26S-01000

# INTRODUCTION

Please read instructions before installing and using your Electronic Air Cleaner. This will help you obtain the full benefit from the Electronic Air Cleaner you have selected. It will also help you avoid any needless service costs that result from causes we cannot control and cannot cover in our guarantee.

If you plan to install this air cleaner yourself, you must realize that the improper use of any tool can be dangerous.

## BASIC TOOLS REQUIRED

- Tin Snip
- Screwdriver
- Rule or Tape Measure
- Drill

**WARNING** Unless you are completely familiar with the necessary tools, equipment, utility connections and potential hazards involved, we ask that you contact a reliable heating and air conditioning dealer or other qualified installer.

## DID YOU GET THE RIGHT SIZE AIR CLEANER

Model 10C26S-01000 is designed for heating or cooling blowers delivering up to 1000 cubic feet of air per minute (cfm.) Model 14C26S-01000 is designed for heating or cooling blowers delivering up to 1400 cubic feet of air per minute, usually found in medium size homes or apartments. Model 20C26S-01000 is capable of handling blowers delivering up to 2000 cfm in larger living units. Before installing your air cleaner, make sure you have selected the proper size unit for your particular requirements.

See specifications on page 9.

## TABLE OF CONTENTS

Rules for Safe Installation and Operation .....	2
How your Air Cleaner Works .....	3
Construction of your Air Cleaner .....	3
Preinstallation .....	4
Installation .....	6
Wiring Instructions .....	6
Operation .....	8
Maintenance .....	8
Optional Equipment .....	9
Specifications .....	9
Parts Illustration .....	10
Parts List .....	11

## GUARANTEE

Electro-Air will not assume any responsibility for component failures due to incorrect installation procedures. See Electro-Air warranty — Packed with the Unit.

## RULES FOR SAFE INSTALLATION AND OPERATION

1. Read the Owners Manual and the Rules for Safe Operation carefully. Failure to follow these rules and instructions could cause a malfunction of air cleaner or unsatisfactory service.
2. **WARNING** Check your local codes and utility requirements before installation. The installation must comply with their directives.
3. **WARNING** Before servicing always shut off electricity. This will prevent any electrical shocks.
4. Follow a regular service and maintenance schedule for efficient operation.

## HOW YOUR AIR CLEANER WORKS

Dirt laden air flowing through the ducts (figure 1) first enters the pre-filters (A) where large particles (hair, lint, etc.) are trapped. Smaller particles (smoke, dust, pollen, etc.) pass through these pre-filters and enter the ionizing section (B). Here each tiny particle receives a positive electrical charge. These charged particles then enter the collecting section (C). This section consists of a series of aluminum plates . . . alternate plates are charged positively.

The positive charge of the particles causes them to be repelled by the positive plates and attracted to the negative plates where they are collected . . . just as a magnet attracts iron filings.

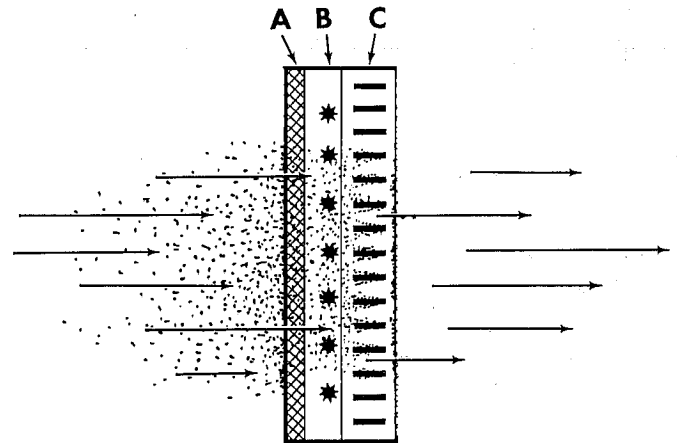

Figure 1

**Thus, only cleaned-filtered air re-enters the supply duct system.**

## CONSTRUCTION OF YOUR AIR CLEANER

Not only is your air cleaner easy to install, it is also easy to operate and maintain. Its basic components, and their functions, are as follows: See Fig. 2.

**Cabinet** — mounts to existing ductwork and houses the collecting cells and pre-filters.

**Collecting Cells** — are made in two sections and perform the actual collecting of dust, dirt, and other impurities from the air. They contain the ionizing and collection sections described above.

Each cell must be installed with the ionizing wires on the air intake side. Each cell must be oriented with the handles and contact button (figure 2) toward the operator.

**Pre-filters** — are in two sections which are interchangeable. They serve as a pre-filter to trap large particles such as hair and lint before they can enter the cell sections.

**Power Door** — contains operating and power on lights as well as the solid state components that convert the 120 volt power supply to the high-voltage, direct current required for the collecting cell.

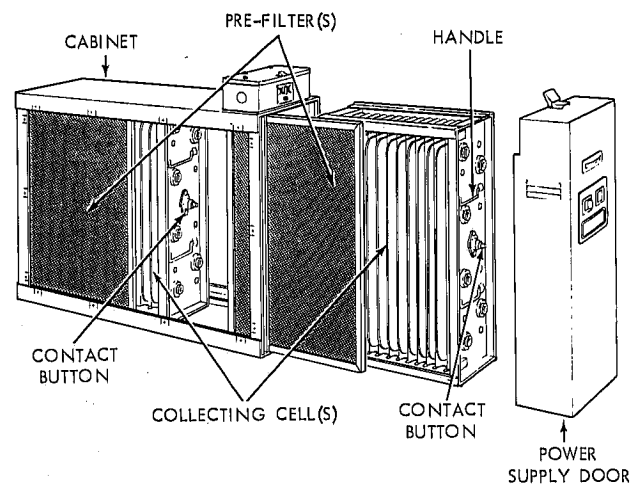

Figure 2

# PREINSTALLATION

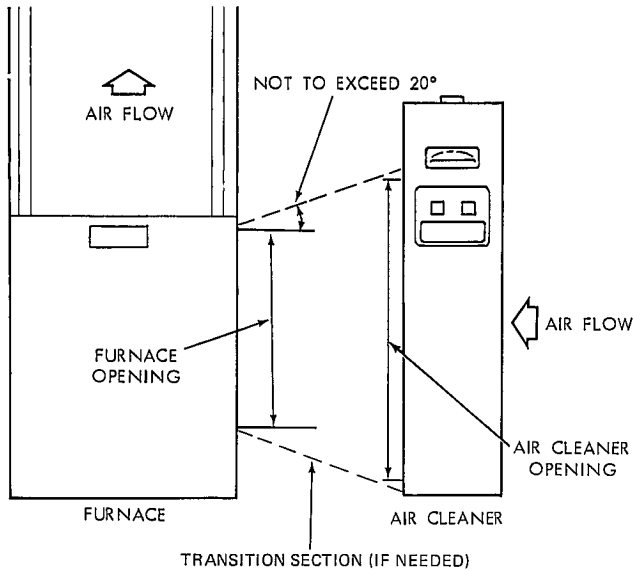

Figure 3

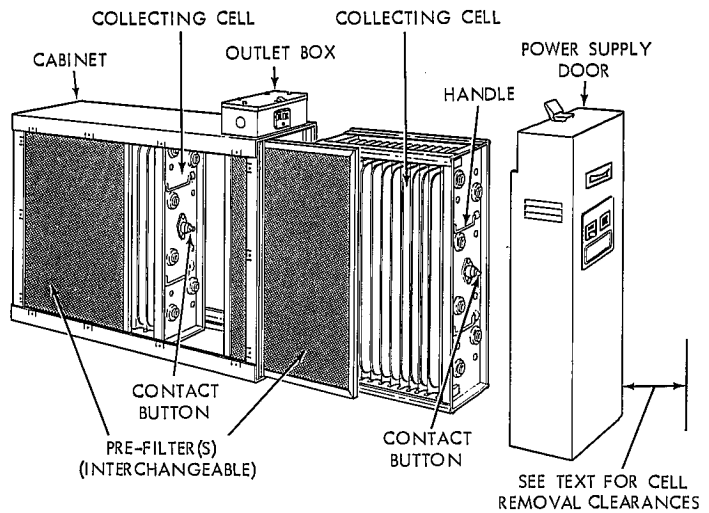

Figure 4

## LOCATING THE AIR CLEANER

Your Electronic Air Cleaner must be mounted in the return air duct of a central forced-air system, on the air entering side of your furnace. (See figure 3 for example).

Select a location that meets the following:

1. The face of the cell will be at a right angle to the air stream.
2. Allow the following clearances to permit removal of cells and pre-filters: (See figures 4 and 5)  
 Model 10C26S-01000 - 15 inches  
 Model 14C26S-01000 - 12 inches  
 Model 20C26S-01000 - 15 inches  
 For complete dimension data refer to figure 5.
3. The air cleaner is not to be placed in the discharge of either the heating or cooling unit.

4. **IMPORTANT:** If atomizing spray type humidifier is used, it must be installed downstream from the air cleaner.

If your furnace duct system has a preinstalled boot, discard front cover of boot and slide the complete air cleaner inside the boot.

If furnace opening cannot be enlarged to required size, a transition sheet metal section must be used. Transition must be planned for each job. Reduction should not be more than 4 inches per lineal foot, approximately 20 angular degrees (figure 3).

## DIRECTION OF AIR FLOW THROUGH THE AIR CLEANER

Your air cleaner is shipped from the factory with air flow from left-to-right. If this air flow is suitable for the installation, no further changes need to be made (figure 4). For right-to-left air flow, remove both pre-filters and cell sections. Turn cells upside down (with the same end facing the cabinet opening). This will locate the ionizing wires at the right, and both contact buttons and cell handles will be facing the power door. Air flow direction

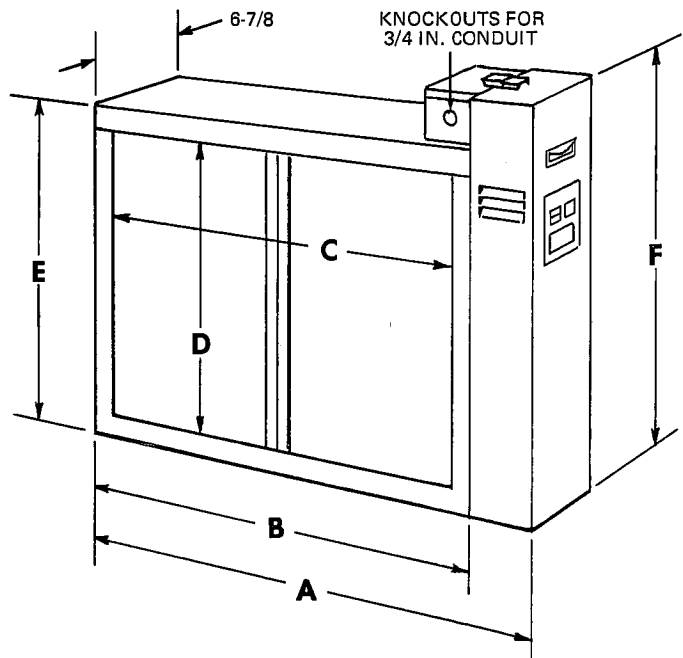

MODEL NO.	A	B	C	D	E	F
10C26S-01000	24 <sup>3</sup> / <sub>4</sub>	21 <sup>5</sup> / <sub>16</sub>	18 <sup>1</sup> / <sub>16</sub>	13 <sup>9</sup> / <sub>16</sub>	16 <sup>7</sup> / <sub>16</sub>	19 <sup>1</sup> / <sub>16</sub>
14C26S-01000	29 <sup>1</sup> / <sub>16</sub>	26 <sup>1</sup> / <sub>4</sub>	23 <sup>5</sup> / <sub>8</sub>	13 <sup>9</sup> / <sub>16</sub>	16 <sup>7</sup> / <sub>16</sub>	19 <sup>1</sup> / <sub>16</sub>
20C26S-01000	29 <sup>1</sup> / <sub>16</sub>	26 <sup>1</sup> / <sub>4</sub>	23 <sup>5</sup> / <sub>8</sub>	17 <sup>3</sup> / <sub>4</sub>	20 <sup>5</sup> / <sub>8</sub>	23 <sup>3</sup> / <sub>8</sub>

Figure 5

must agree with arrow embossed on end of collecting cells.

After installing the cell sections, install pre-filters in cabinet tracks on the right. This will again place the pre-filters on the intake side (on the same side as ionizing wires).

# TYPICAL MOUNTING POSITIONS

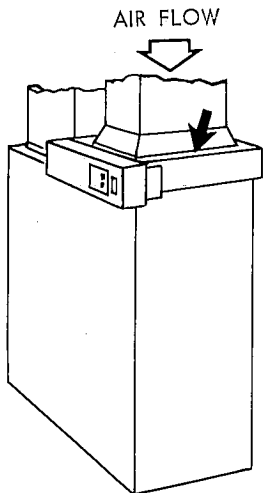

Figure 6

## BASEMENT FURNACE (LOWBOY) (figure 6)

Cleaner is mounted horizontally in return plenum - just above the furnace.

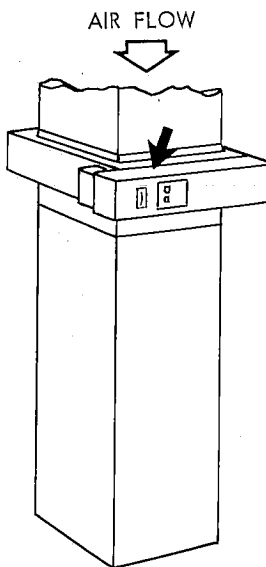

Figure 7

## COUNTERFLOW FURNACE (figure 7)

Cleaner is mounted horizontally in return duct or plenum, just above furnace.

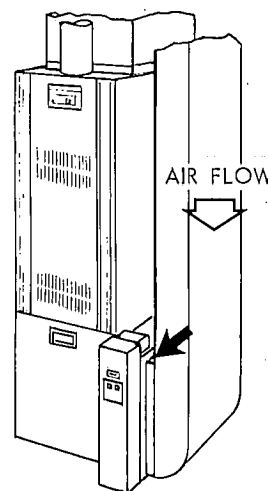

Figure 8

## HIGHBOY FURNACE (figure 8)

Side installation. Cleaner is mounted vertically, where return enters side inlet of furnace.

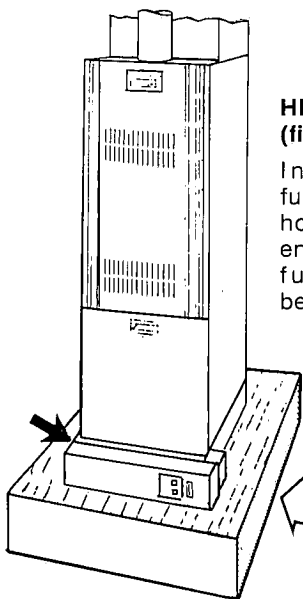

Figure 9

## HIGHBOY FURNACE (figure 9)

Installation beneath furnace. Cleaner mounts horizontally, where return enters from below. Raise furnace and install beneath base.

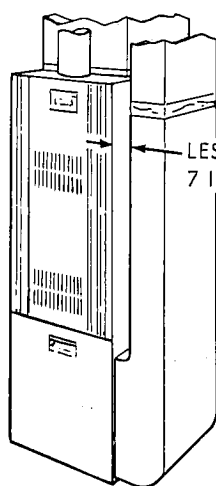

Figure 11

## INSTALLING OFFSET (figure 11) Typical use of duct offset to match air cleaner opening.

If duct connection to furnace allows less than nine inches for mounting the air cleaner, shorten the lateral trunk, or attach an offset fitting to the elbow (figure 11).

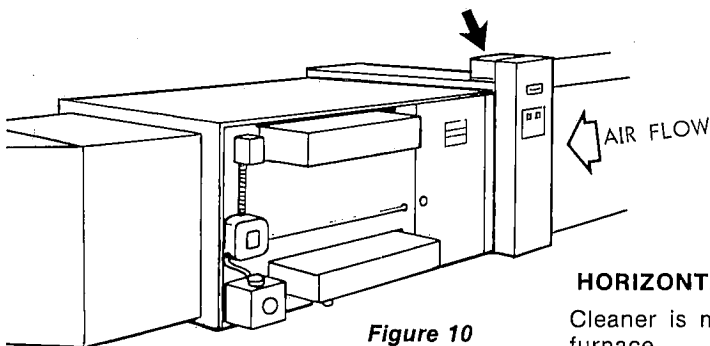
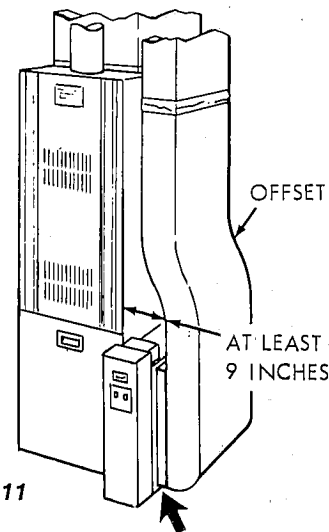

Figure 10

## HORIZONTAL FURNACE (figure 10)

Cleaner is mounted vertically in the return duct, near furnace.

# INSTALLATION

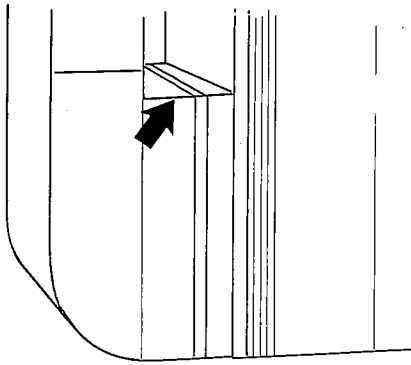

Figure 12

## REMOVE OLD FILTER AND DISCARD (figure 12)

**NOTE:** This filter may be mounted in the furnace compartment.

## CLEAN BLOWER COMPARTMENT

**NOTE:** The air cleaner cannot remove dirt from blower and ducts.

## INSTALLATION

The following is a typical installation of the air cleaner on a "High-boy" furnace. (figure 8).

1. Place the air cleaner on the floor. Stand it upright with the power door facing you (figure 4). If a horizontal installation is being planned, lay the air cleaner on its side, this will help you to visualize the relative location of all parts.

Allow ample space for wiring and servicing the power supply box (figure 13).

2. Release the latch, remove the power door (by grasping handle and pulling door away from cabinet) and set it aside (figure 4). Remove the collecting cells and pre-filters. Set pre-filters and cells aside in a safe location until the cabinet is installed.

3. Set the cabinet next to the furnace at selected location. If necessary, enlarge the opening in the furnace (if possible) to match the opening in the cabinet.

If the furnace opening cannot be enlarged, a transition fitting should be used. (figure 3)

The cabinet can be attached directly (figure 13), or a starting collar can first be fitted to the furnace inlet. A butt or slip joint can be used.

Securely attach the cabinet to furnace inlet, using at least two of the mounting holes on each side of the cabinet.

4. Using butt joint, attach ductwork (normally an elbow) to the upstream side of air cleaner cabinet. (Note the use of the sheet metal turning vanes inside the elbow (figure 14) to improve air distribution over the face of the cells.)

**NOTE:** An optional method of attaching ductwork to cabinet is to modify the cabinet (figure 15) by bending the tabs outward at a 90° angle and attaching ductwork to tabs.

### Transition Fittings

If the air duct does not fit the cabinet opening, a transition fitting should be used. Gradual transitions are preferred for greatest cleaning efficiency. Not more than four inches per lineal foot (approximately 20° angle) should be allowed (figure 3).

5. Connect the vertical duct section to the elbow. Wedge a wood block between floor and elbow for support (figure 16).

6. Seal all joints in the return air system, downstream from the air cleaner, with duct tape to prevent dust from entering the cleaned airstream. Tape is usually applied on the outside of ducts, but may also be applied on the inside, or both.

### 7. WIRING

After the cabinet has been installed the air cleaner is ready for wiring.

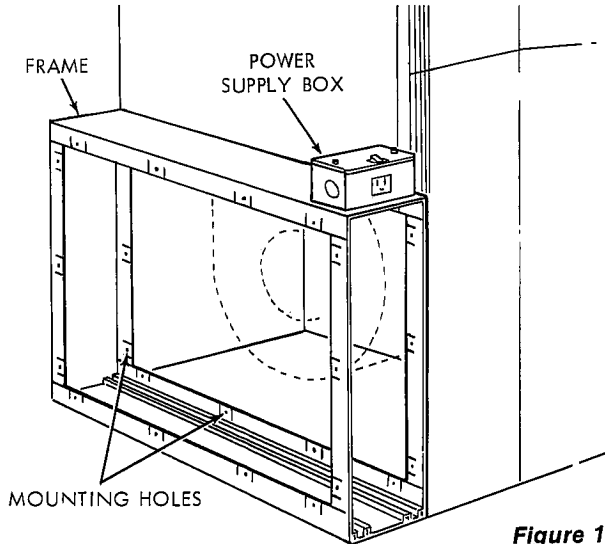

Figure 13

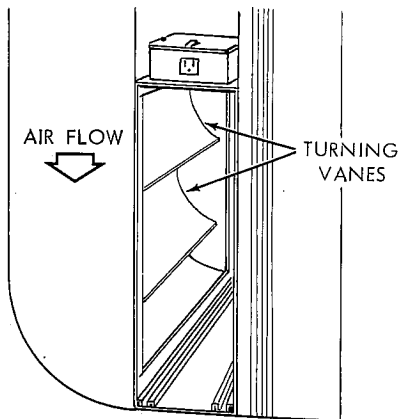

Figure 14

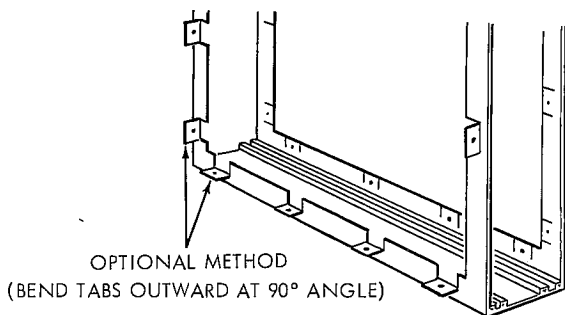

Figure 15

**NOTE:** When wiring the Electronic Air Cleaner through the furnace controls, caution must be exercised to assure proper electrical connection to the Air Cleaner (figure 19). An optional Air Flow Monitor is available thru your heating & air conditioning contractor. Electro-Air recommends the Air Cleaner be wired through the Furnace Controls or use the optional Air Flow Monitor. The Air Cleaner should not be running unless furnace blower is on.

8. With the cabinet installed, re-install pre-filter(s) and

collecting cell(s) (figure 20).

**NOTE:** The contact button and handles on the cell, must be facing you and ionizing wires must be on the air intake side.

Install the power supply door as follows: Engage the lip on lower inside edge of door in the flange on cabinet and carefully close the door, making sure that the electrical connector prongs on the door enter the slots in the socket on the cabinet. When the door is fully in place, engage the latch and snap it closed.

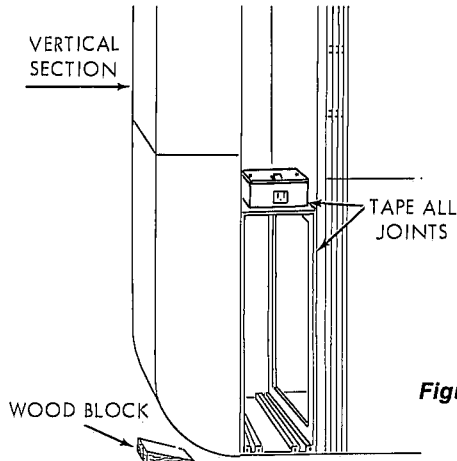

Figure 16

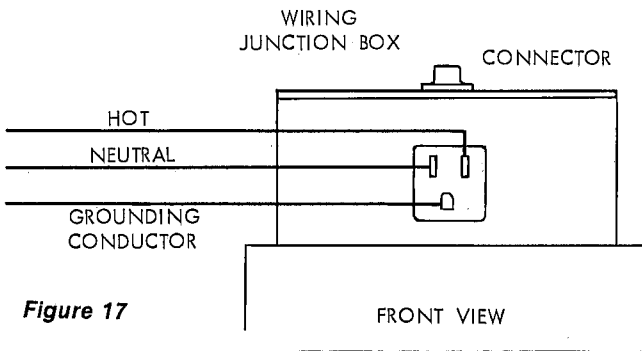

Figure 17

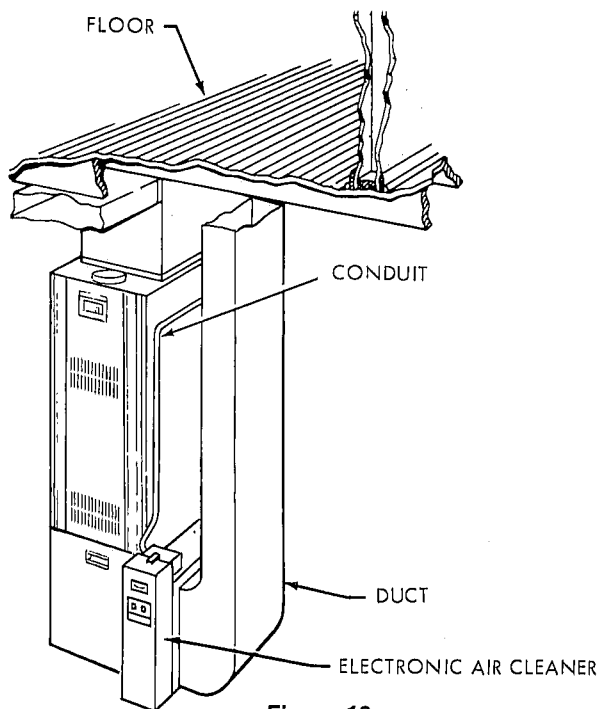
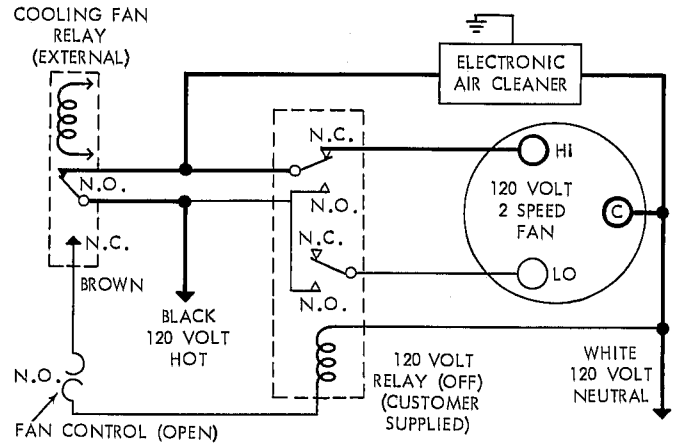
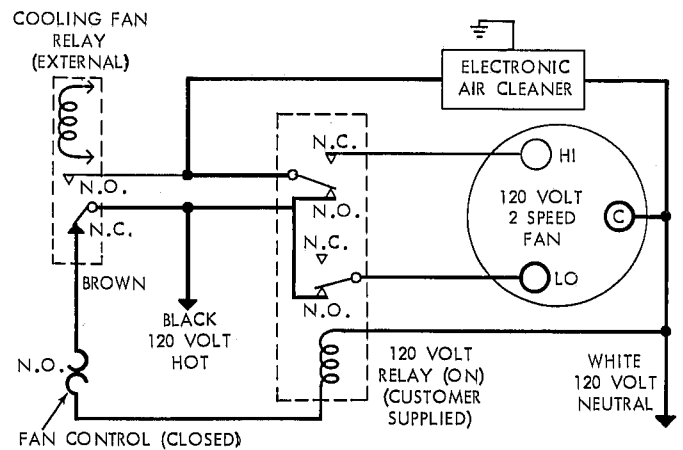

Figure 18



COOLING MODE — FAN OPERATING IN HI SPEED



HEATING MODE — FAN OPERATING IN LOW SPEED

Figure 19

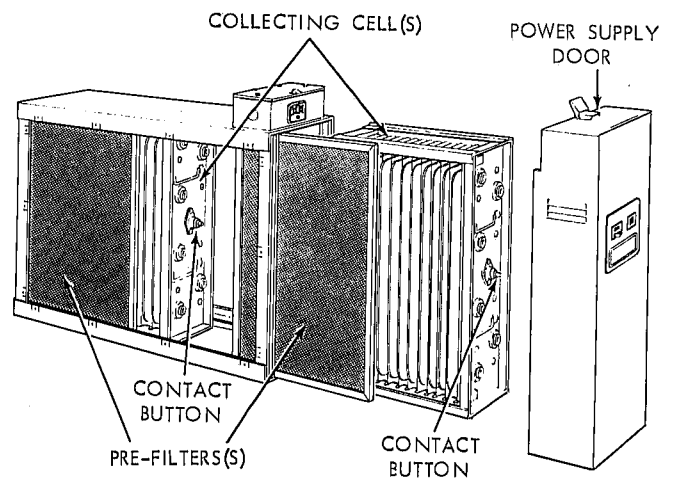
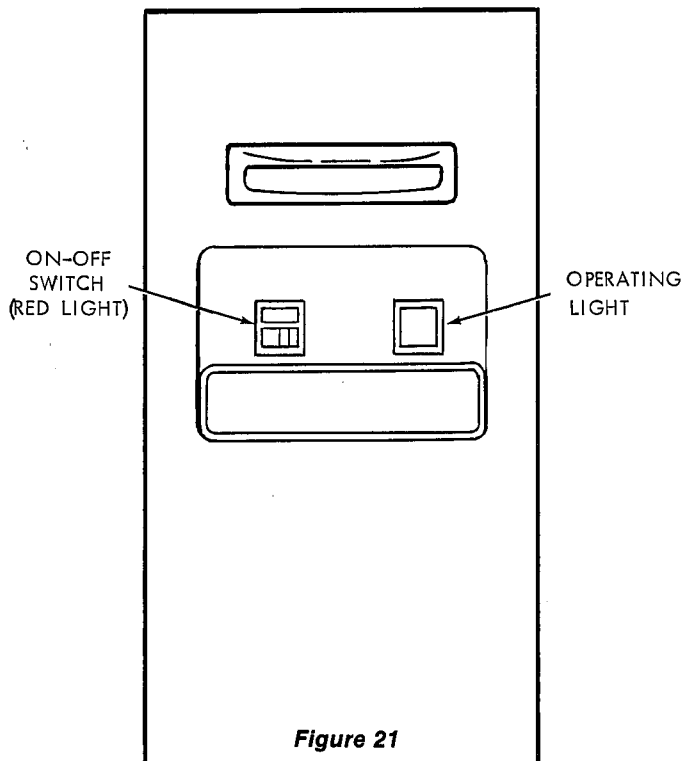

Figure 20

# OPERATION



1. Push the ON-OFF switch to the on position. (figure 21). When the power is on, the ON-OFF switch light will be on.
2. With the fan running and the ON-OFF switch on (red light on), the air cleaner will be activated. An arcing or "snapping" sound will often be heard which is normal and is an indication that the unit is operating.
3. The operating light should be on. When off, the operating light indicates that the cell(s) need washing, or that trouble exists in the unit.  
If, after washing the cell(s), the operating light remains off, the cell(s) could be improperly placed in the cabinet, or needs servicing.

**NOTE:** An occasional flicker of the red light accompanied by harmless sparking or snapping noise is normal. It is caused by trapping large particles of dirt. If arcing is continuous, the cells should be washed.

# MAINTENANCE

For maximum efficiency your air cleaner cell(s) and pre-filter(s) should be inspected once a month and cleaned when necessary. Cleaning will usually be required every one to 3 months, depending upon the particular household circumstances. When cleaning is required the following procedure should be used:

## CLEANING

1. Turn the air moving system "OFF."
2. Push the ON-OFF switch on the power pack to the OFF position (figure 21). Wait 15 seconds and both the power pack and the collecting cell(s) will be automatically discharged.
3. Release the latch on top of power pack and pull the power pack straight away from cabinet at the top. Then lift pack out of ledge at bottom edge of cabinet. Set power pack aside.
4. Remove the cell(s) and pre-filter(s) from cabinet. Using a solution of warm water and low sudsing detergent, soak cell(s) and pre-filter(s) for 20 to 30 minutes.

**NOTE:** Ionizing Wires may become coated causing loss of cleaning ability by the Collecting Cell. Using a damp cloth, wipe each Ionizing Wire, exercising care not to damage them.

5. Remove the cell(s) and pre-filter(s) from solution and rinse thoroughly with clean water.
6. Allow cell(s) and pre-filter(s) to drip dry for a **minimum of 2 hours**. Cell(s) and pre-filter(s) may be tipped at a slight angle to expedite the drip-dry process.
7. Reinstall the cell(s) and pre-filter(s) in the cabinet.
8. Replace the power pack. Start furnace fan running. After 30 minutes push ON-OFF switch on the power pack to the ON position.

A moderate amount of arcing or "snapping" may occur at this time, which will indicate that the cell(s) are still damp. If the noise is objectionable, push the ON-OFF switch to the "OFF" position and allow additional time for cell(s) and pre-filter(s) to dry. In some cases the operating light will remain OFF during this initial activation of the air cleaner, and this would indicate that the cell(s) are not completely dry. The operating light should remain ON once the drying is complete.

SPECIFICATIONS	AIR CLEANER MODEL NUMBERS		
	10C26S-01000	14C26S-01000	20C26S-01000
RATED CAPACITY	1000 CFM	1400 CFM	2000 CFM
MAX. PRESSURE DROP	.08 IN. W.G.	.08 IN. W.G.	.09 IN. W.G.
CELL WEIGHT	(2) 7 LBS. EACH	(2) 9 LBS. EACH	(2) 11 LBS. EACH
POWER PACK WEIGHT	8 LBS.	8 LBS.	9 LBS.
UNIT WEIGHT	34 LBS.	41 LBS.	44 LBS.
POWER CONSUMPTION	40 WATTS (MAX)	40 WATTS (MAX)	40 WATTS (MAX)
ELECTRICAL INPUT	120 V. 60 Hz.	120 V. 60 Hz.	120 V. 60 Hz.
ELECTRICAL OUTPUT	1.25 MA @ 6500 VDC (NOM)	1.2 MA @ 6400 VDC (NOM)	2.0 MA @ 6500 VDC (NOM)
MAX. OZONE OUTPUT	.05 PPM	.05 PPM	.05 PPM
TEMPERATURE RATING	40° F. TO 85°F.	40°F. TO 85°F.	40°F. TO 85°F.

# PARTS ILLUSTRATION

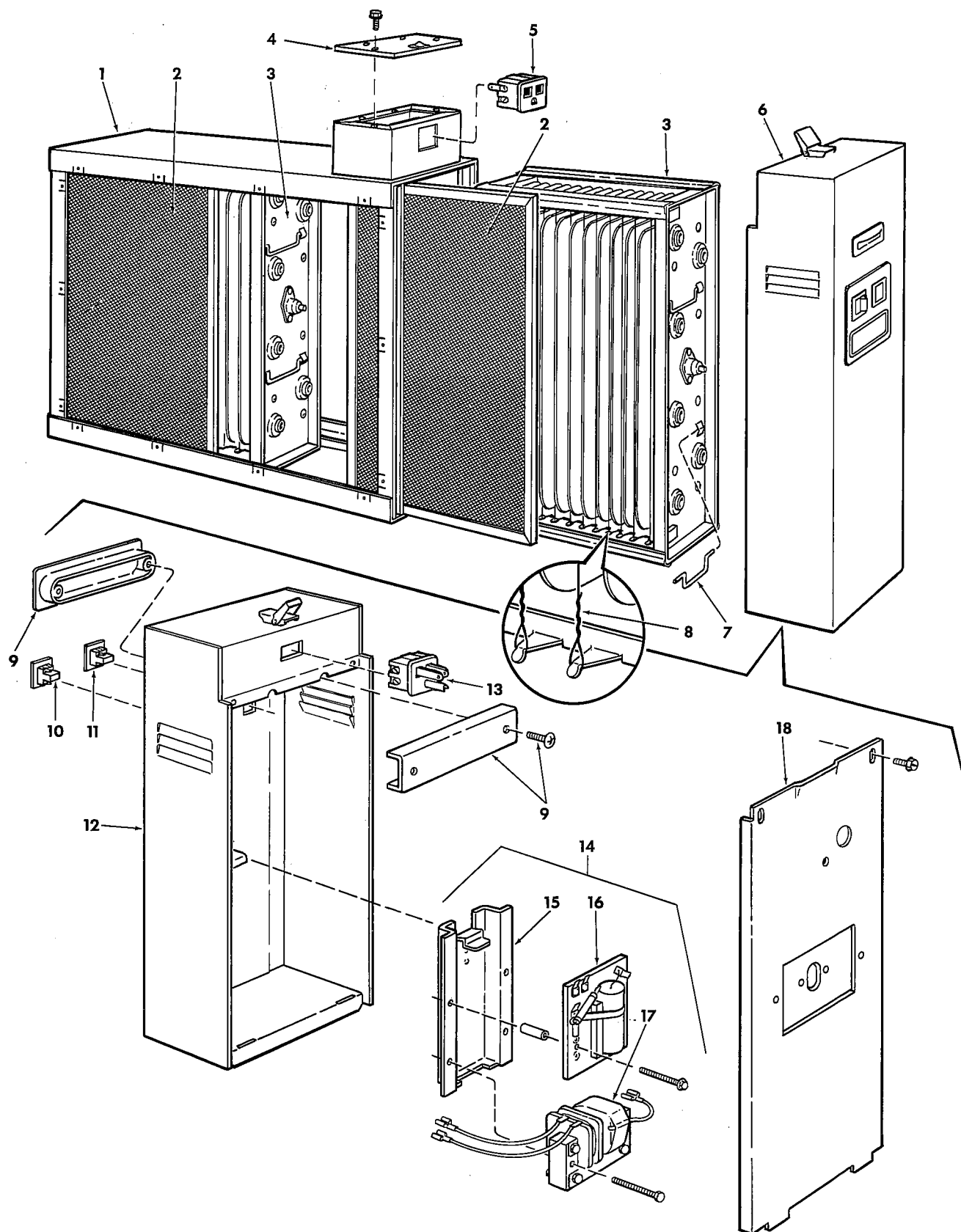

# PARTS LIST

## ELECTRONIC AIR CLEANERS MODEL NOS. 10C26S-01000, 14C26S-01000 and 20C26S-01000

WHEN ORDERING REPAIR PARTS, ALWAYS GIVE THE FOLLOWING INFORMATION AS SHOWN IN THIS LIST.

1. The PART NUMBER
2. The PART DESCRIPTION
3. The MODEL NUMBER
4. The NAME OF ITEM — Electronic Air Cleaner

**Always Order by "Part Number" . . . Never by "Item No."**

ITEM NO.	DESCRIPTION	Part Number		
		10C26S-01000	14C26S-01000	20C26S-01000
1	Cabinet Assembly .....	F808-0557	F808-0556	F808-0555
2	Pre-filter (2 Req'd) .....	F825-0431	F825-0432	F825-0338
3	Cell Assembly (2 Req'd) .....	F811-0398	F811-0397	F811-0319
4	Cover Assembly .....	F838-0072	F838-0072	F838-0072
5	Connector, Female .....	F818-0053	F818-0053	F818-0053
6	Power Pack Assembly .....	F858-0692	F858-0692	F858-0691
7	Handle, Cell .....	F832-0039	F832-0039	F832-0039
8	Ionizing Wire .....	F843-0484	F843-0484	F843-0500
9	Handle (with Screws and Support) .....	F832-0030	F832-0030	F832-0030
10	Light, Operating .....	F844-0102	F844-0102	F844-0102
11	Switch, On-Off .....	F876-0160	F876-0160	F876-0160
12	Cabinet Assembly, Power Pack .....	F858-0693	F858-0693	F858-0694
13	Connector, Male .....	F827-0026	F827-0026	F827-0026
14	Power Supply Assembly (includes items 15,16,17)	F858-0488	F858-0488	F858-0448
15	Bracket .....	F806-0436	F806-0436	F806-0436
16	P. C. Board Assembly .....	F859-0227	F859-0227	F859-0227
17	Transformer .....	F881-0176	F881-0176	F881-0175
18	Cover, Power Pack .....	F820-0098	F820-0098	F820-0220

# WHITE-RODGERS



White-Rodgers Division, Emerson Electric Co.  
9797 Reavis Road, St. Louis, MO 63123  
(314) 577-1300



Printed in U.S.A.

846-0256