

Electro-air[®]

WATER WASH

ELECTRONIC AIR CLEANERS

**INSTALLATION
MANUAL**

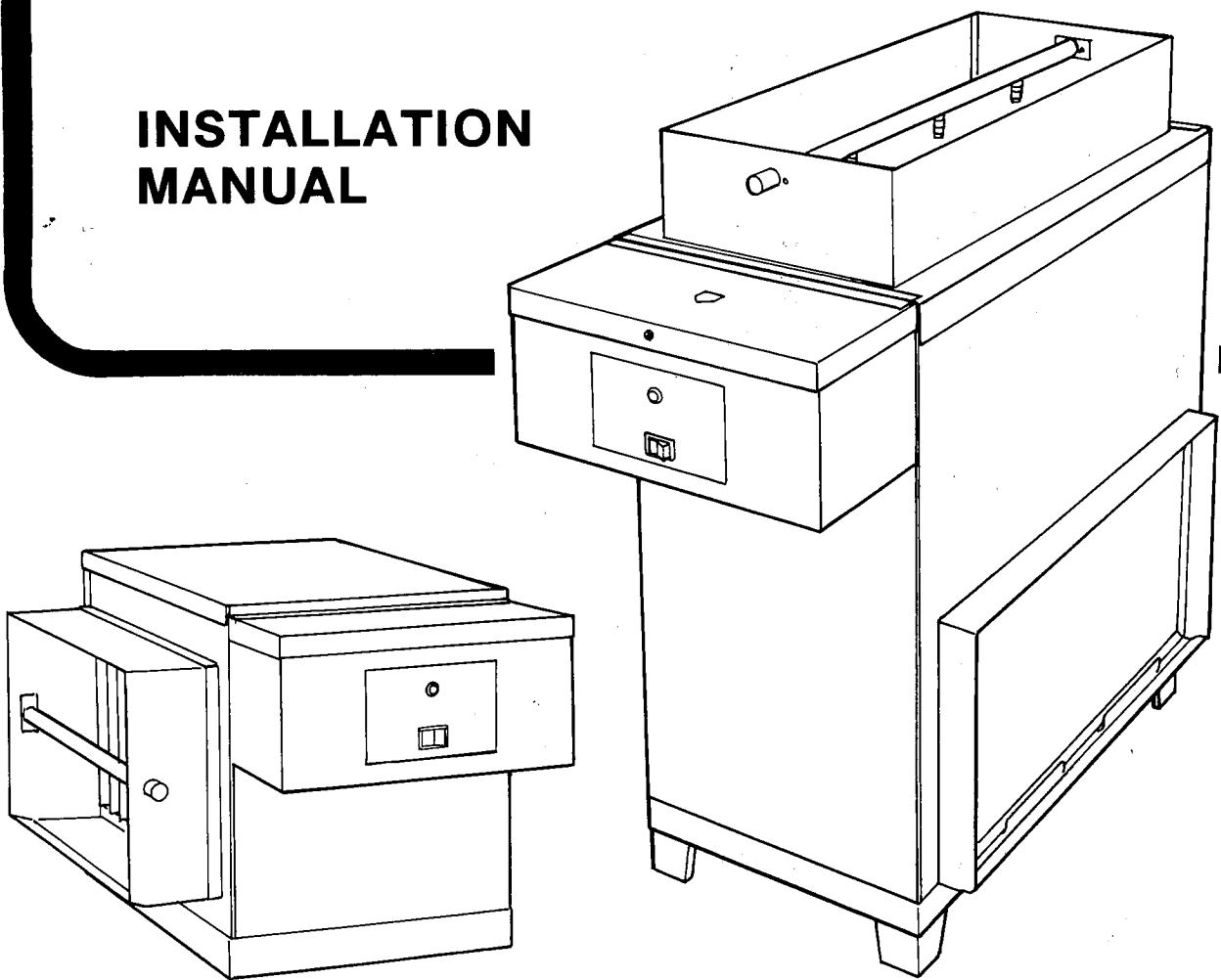

MODEL NUMBERS

14C12H-01000

14C12V-01000

20C12H-01000

20C12V-01000

APPLICATION

The electronic air cleaner is a product that is designed to remove dirt, dust, cooking and tobacco smoke, bacteria, pollen and other airborne contaminants from the air circulating through a forced air heating/cooling system.

The dirt particles are electrostatically charged in a collecting cell that consists of an ionizing section and a series of aluminum plates. The dirt particles cling to the plates, allowing clean air to recirculate throughout the air handling system.

Water Wash units are deluxe models specifically designed for installation in residential buildings. They feature extra-large collecting cells for increased dirt loading capacity, and a built-in water manifold that washes the cell without disassembling the unit.

Two CFM sizes are available: 1,400 and 2,000 CFM. Each CFM size is available in both horizontal and vertical configurations, making a total of four models in the entire line.

TYPICAL WATER WASH INSTALLATION — This vertical flow unit has been installed with a hand valve wash control. The cabinet is reversed for right to left airflow.

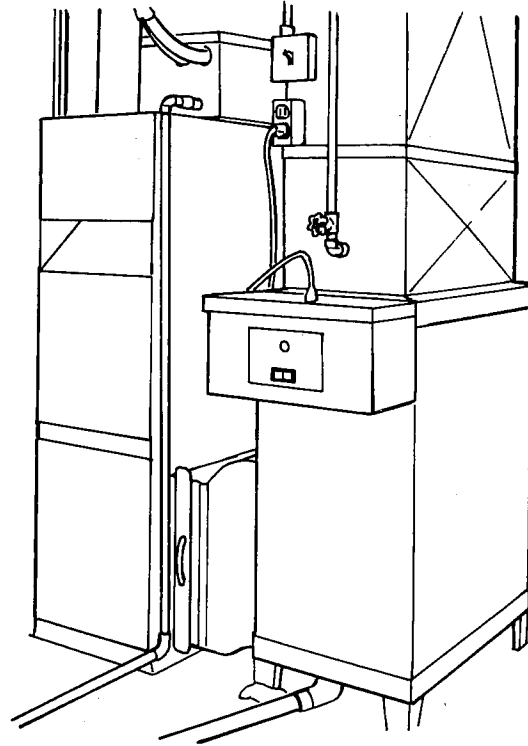

MAJOR PARTS

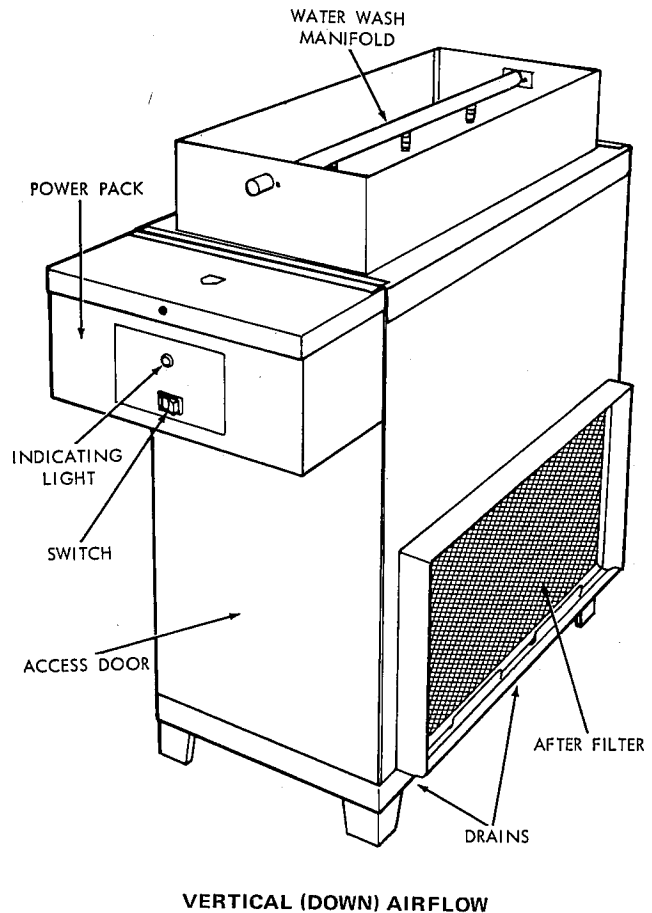
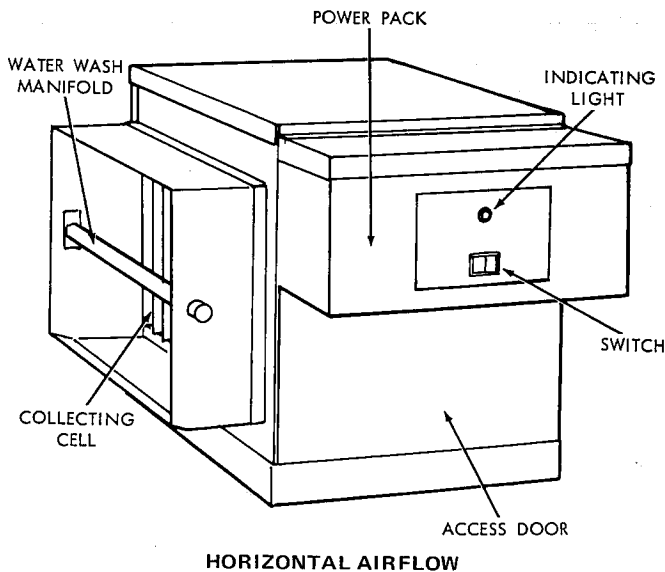

The Water Wash unit is composed of the following components:

1. **COLLECTING CELL** — This component consists of an ionizing section, that is constructed of tungsten wires suspended between electrodes, and a series of parallel aluminum plates. The dirt particles are electrostatically charged in the ionizing section and collected on the cell plates.
2. **POWER PACK** — The electrical components required to furnish high voltage current for the collecting cell are housed here. The power pack consists of a ferroresonant power supply. An indicating light showing that power is being supplied to the air cleaner is mounted to the front. An ON/OFF rocker switch is also positioned on the front.

3. WATER MANIFOLD — This deluxe feature consists of a 3/4" copper pipe, fitted with spray nozzles, that is positioned above or beside the collecting cell. The manifold is connected to a hot water supply. When the hot water is permitted to enter the manifold, it sprays the dirty collecting cell until it is flushed clean. A drain connection in the bottom of the cabinet carries away the dirty water.

4. CABINET — The cabinet and power pack housing are constructed of heavy-duty, 20 gauge steel. Duct connections are easily made with the air outlet collar.

Vertical units are manufactured for airflow down and out the right side. Horizontal cabinets are shipped with airflow from left to right. The direction of airflow can be changed easily if the installation requires it.

PACKAGING

Vertical Water Wash units are shipped in one carton, and horizontal units are shipped in two cartons. Both units are shipped with the cell, manifold and after filter in position. The power pack for vertical units is shipped inside the

cabinet. The power pack for horizontal units is shipped in the smaller of the two cartons. Vertical units are shipped with the legs attached. Optional legs for horizontal units can be ordered as an accessory.

WASH SYSTEMS

The convenience of washing the collecting cell while it is assembled inside the electronic air cleaner, is one of the most desirable features of the product. Each water wash unit is equipped with a built-in manifold to spray the dirty collecting cell with hot water until it is flushed clean.

There are several methods of providing hot water to the manifold. Several convenience accessories to automate the process are also available.

HAND VALVE

This standard technique includes a 3/4" water line and hand valve (stop and drain) permanently connected to the portion of the manifold protruding from the front of the electronic air cleaner. The water temperature must not exceed 140° F. since higher temperatures may cause steam to carry through the duct system. The supply should not be reduced below the 3/4" size. The valve is usually installed at the point where the manifold is soldered to the hot waterline. However, it can be placed at any accessible point in the waterline.

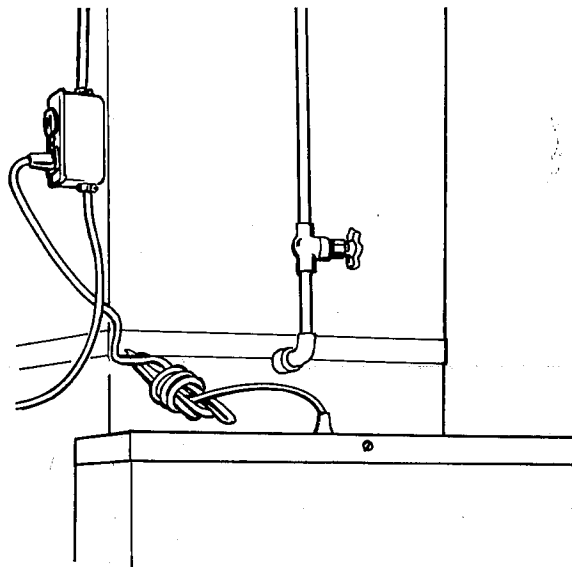

Hand valve in hot waterline connected to manifold above power pack.

SPRAY-KLEAN

This optional control is designed as an electrical interlock between the power supply, air handling equipment and water supply. The control shuts off the air cleaner and the other air handling units at the same time, before the wash cycle is initiated by turning the hand valve that is inside the Spray-Klean box. Operating instructions are mounted inside the control box.

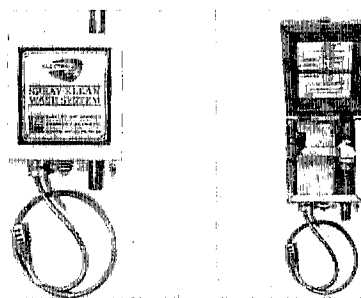

Spray-Klean electrical interlock control.

SPRAY-MATIC

This optional device completely automates the unit's washing cycle. It consists of a control box which houses a seven-day automatic time clock and wash control timing mechanism. On a specific day and hour, the Spray-Matic will turn off the air handling system's power and release hot water into the spray manifold to wash the cell. After a complete washing it will turn the water off, permit time for the collecting cell to drip dry, turn the air handling system's blower on to force dry the collecting cell and reactivate the air handling equipment after the washing cycle has been completed. The mechanism can also be triggered manually at any time desired. A permanent drain connection must be employed with this method. Complete operating instructions are mounted inside the control box.

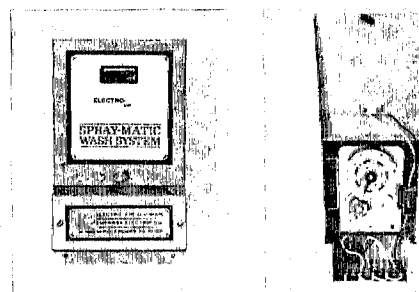

Spray-Matic control to automate wash cycle.

INSTALLATION

SIZING

The first factor to be considered in designing an installation is proper sizing of the unit. To do this, determine the number of cubic feet of return air to be cleaned by the unit each minute (CFM). The second most important factor is assuring the uniform distribution of the air over the face of the cell.

Most air ducts are designed to handle air at velocities greater than that which is permitted through the electronic air cleaner. It is, therefore, often necessary to expand the duct work on the entering air side. Depending on the equipment following the air cleaner, it may or may not be necessary to reduce the duct work on the leaving-air side. In either case, the transition should, if possible, maintain a maximum contraction ratio of 1 in 3, (approximately 20 degrees) so that turbulence is held to a minimum and even air distribution is obtained.

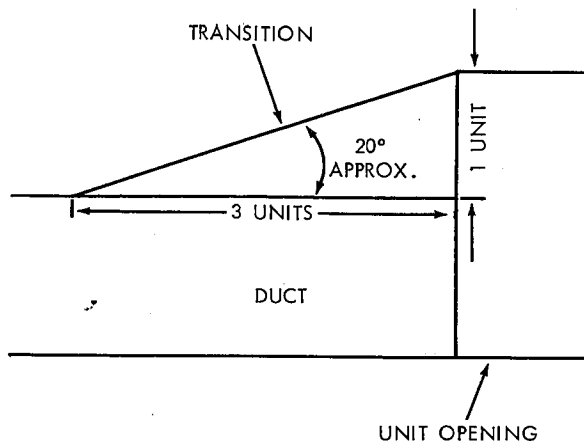

Air cleaners installed within 6 feet of a FRESH AIR INTAKE should have pre-filters installed ahead of the cell. This prevents airborne trash, water and snow droplets, insects, and other contaminants from being drawn into the unit and causing excessive and sometimes objectionable arcing.

UNIT LOCATION

The electronic air cleaner is always installed in the return air duct where it can clean the air before it continues through the other air handling equipment for treatment.

HORIZONTAL REQUIREMENTS

The horizontal cabinet is designed so that it can be suspended from ceiling joists or equipped with legs for floor mounting. A hole with a 3/8" threaded nut welded inside the cabinet is provided in each corner of the top panel so that the unit can be attached to suspension bolts hanging from the ceiling.

DISASSEMBLING THE UNIT – The larger carton contains the cabinet, cell and after filter. Remove the unit from the carton. The cell and after filter should be removed from the cabinet before it is placed in the duct work.

Access to the interior of the cabinet is achieved by removing the front access door (with power pack clip mounting). Remove the cell by unscrewing the shipping plate. The after filter can be removed by lifting it out of the bottom channel and swinging it inward. The empty cabinet is now ready for installation if left to right airflow is required.

AIRFLOW REVERSAL – If the installation calls for airflow that is a right to left, the following procedures

should be followed to change from the left to right shipping position:

1. Remove the back panel from the empty cabinet.
2. Turn the cabinet 180° around so that the collar with the water manifold is on the air intake side.
3. Replace the back panel (without mounting clip) on the back of the cabinet.
4. Standard installation procedures can now be followed.

Make sure that the cell is also reversed 180° when it is inserted into the cabinet. The air must enter through the ionizing section. (Side with thin tungsten wires.)

5. If desired, the water manifold can also be reversed to make water connections on the opposite side of the cabinet. This is accomplished by removing the small screws holding the sealed end of the manifold to the inside of the collar. The manifold is reinserted in the hole on the opposite side of the collar. Replace screws.

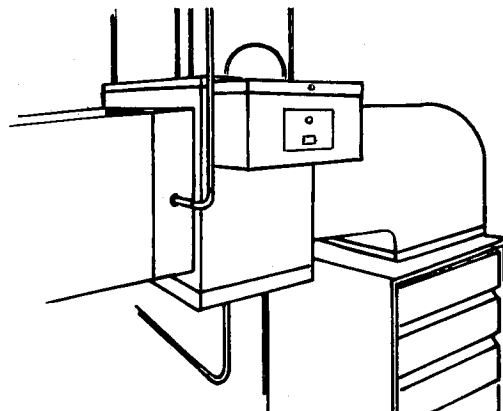

Horizontal airflow/ceiling suspended in basement from floor joists.

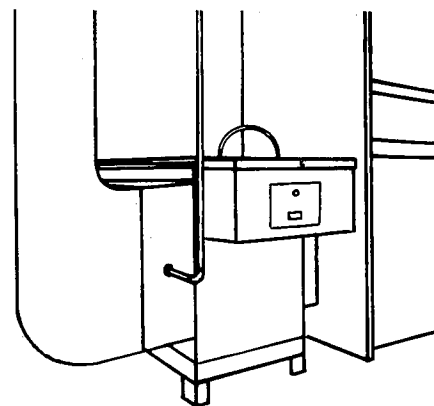

Horizontal airflow/floor mounted in basement using optional legs.

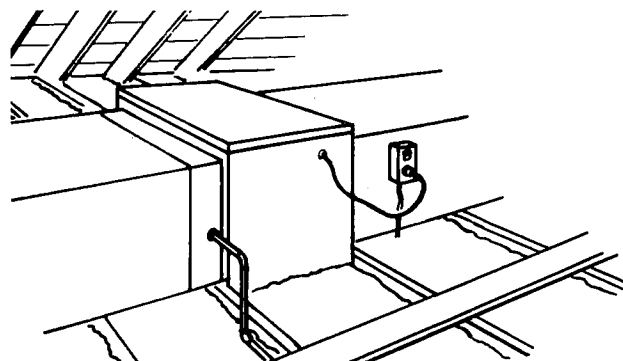

Horizontal airflow/installed in attic crawl space with remote controls.

FLOOR MOUNTING — If the unit is to be positioned on the floor, four optional mounting legs should be used. The legs are pre-drilled with clearance holes for 1/2" #10 round head sheet metal screws which are furnished. Holes should be drilled in the four corners of the drain pan with a 1/8" high-speed drill. Use the legs as a template. Fasten a leg to each corner with the provided sheet metal screws.

VERTICAL REQUIREMENTS

The vertical cabinet is designed for floor mounting. The unit is shipped with assembled legs and no weld nuts in its top for suspension.

DISASSEMBLING THE UNIT — The carton contains the cabinet, cell, power pack and after filter. Remove the unit from the carton. The cell, power pack and after filter should be removed from the cabinet before it is placed in the duct work. Access to the interior of the cabinet is achieved by removing the front access door (with power pack clip mounting). Remove the cell by unscrewing the shipping plate. The after filter can be removed by lifting it out of the bottom channels and swinging it inward. The power pack is removed by unscrewing the wing nut and lifting it and the cardboard liner out. The empty cabinet is now ready for installation if an airflow that is down and out the right side of the unit is desired.

AIRFLOW REVERSAL — If the installation calls for airflow that is down and out the left side, the following procedures should be followed to change from the down and out the right side shipping position:

1. Remove the back panel from the empty cabinet.
2. Turn the cabinet 180° so that the collar on the side of the cabinet is now on the air intake side.
3. Replace the back panel (without mounting clip) on the back of the cabinet.
4. If desired, the water manifold can also be reversed to make water connections on the opposite side of the cabinet. This is accomplished by removing the small screws holding the sealed end of the manifold to the inside of the collar. The manifold is reinserted in the hole on the opposite side of the collar. Replace screws.

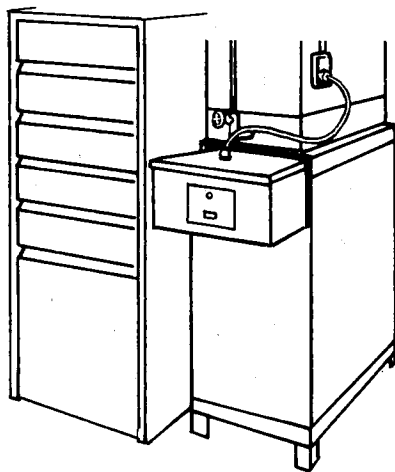

Vertical airflow/basement installation cabinet reversed for right to left.

DRAIN CONNECTION

The convenience of washing the collecting cell in place requires that a provision must be made to drain the dirty water flushed by the spray manifold.

Usually this requirement is met by providing a roll of plastic drain hose, attached to the drain in the bottom of the unit's cabinet. The plastic drain hose is coiled under the

unit and is unrolled to the nearest floor drain when cell washing is performed.

Deluxe installations feature a permanent metal or hard plastic pipe connected to the floor drain. (In new home construction, the pipe may be imbedded in the basement floor before the cement is poured.)

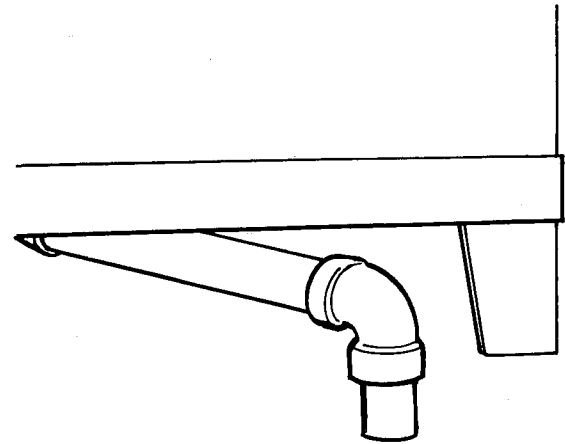

Permanent drain installation.

DRAIN FITTINGS — Two 1/2" NPT plastic drain fittings are provided with each unit for use in the cabinet's bottom drain pan. The pan has two drain holes, one at each end, for convenience in making the drain connection. Only one hole is used; the other is blocked. The procedure is as follows:

1. Select the drain hole that is most convenient to the nearest household drain.
2. Place the plastic drain fitting, with the open core, into the selected hole. The elbow must be placed beneath the cabinet with one rubber washer between the metal surface and the elbow. Screw the open core into the elbow through the sheet metal, using the flanges provided. (Only hand pressure should be used to tighten the fitting.)
3. Place the other elbow and solid core into the remaining cabinet hole so that it is blocked.
4. Connect either 1/2" pipe or the plastic drain hose to the plastic elbow. When using standard pipe, do not use the plastic drain fitting as a lever. Furnace wire or duct tape can be used to secure the plastic drain hose to the fitting.

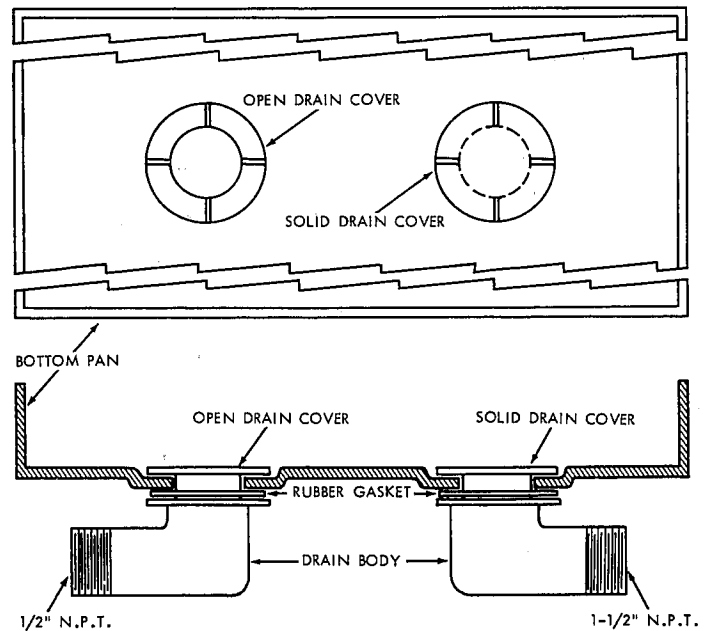

DUCT CONNECTION

The empty cabinet can now be placed in the return air duct. Make sure that the transition requirements specified under the SIZING section are followed.

PITCH DUCT WORK — Slope the bottom edges of the duct work toward the air cleaner. This permits any water accumulated in the ducts to flow back into the drain pan.

WATER LEAKS — After the air cleaner has been joined in the duct, all joints must be carefully caulked so that a tight air and water seal is assured.

The correct procedure is to put a thick bead of caulking around the air inlet collar and air leaving flange on horizontal units, and around the air leaving flange on vertical units. The transitions and duct work should be screwed directly into the caulking.

HOT WATER SUPPLY — With the cabinet permanently installed in the duct work, proceed to make the appropriate hot water connections for whatever system selected from the options listed on page 2.

Complete instructions for the Hand Valve method is printed on page 2. Installation instructions for the Spray-Klean semi-automatic control, and Spray-Matic completely automatic control are packed with each accessory.

The following amounts of hot water, (at least 125° F, no more than 140° F) are required for at least three minutes of washing each time the cell is cleaned in place:

WW-14-H/V = 4.9 GPM
WW-20-H/V = 4.9 GPM

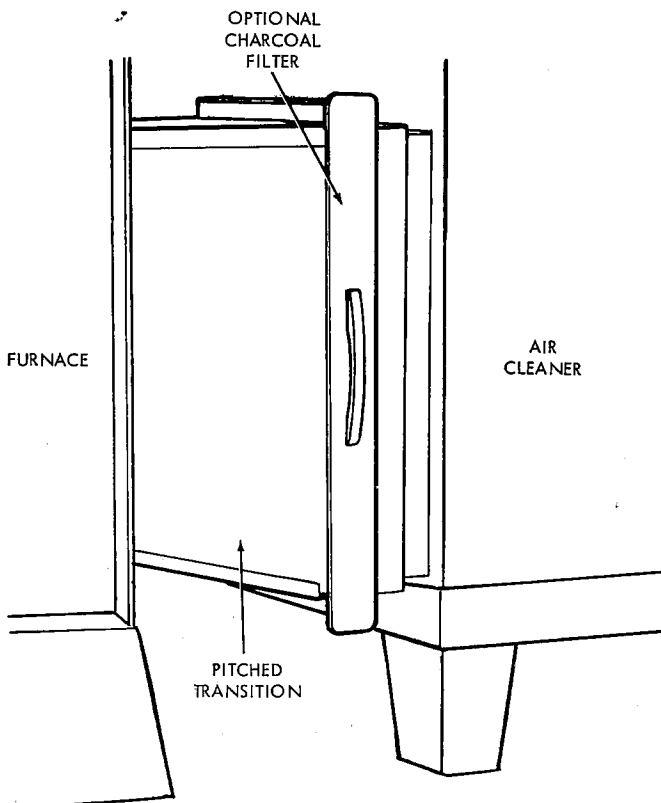

ELECTRICAL REQUIREMENTS

The only electrical requirement is a 10 amp, 120 volt, 60 cycle, ordinary single phase lighting circuit.

Usually the supplied length of grounded 120 volt, power cord is plugged from the power pack to a nearby power

receptacle that is directly wired to the air handling equipment's fan control. (See Part 2)

The air cleaner must be grounded to prevent potential electrical shock.

1. POWER PACK

The component houses the primary electrical components and operating controls. It is usually mounted on the front of the electronic air cleaner. However, some installations (attic, crawl space, etc.) may necessitate the power pack being separated from the air cleaner and positioned in a remote location where it can be easily reached.

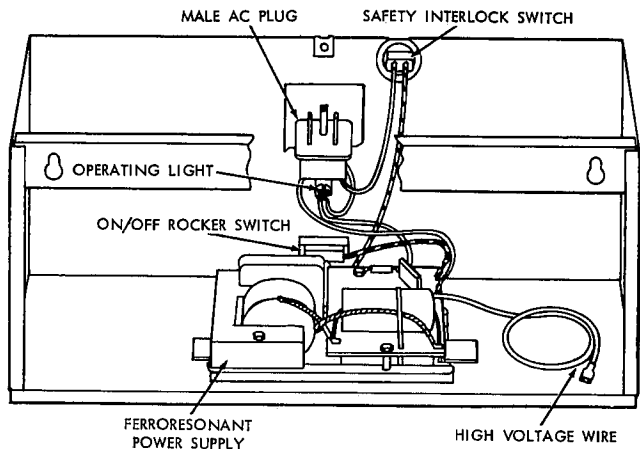

REASSEMBLE UNIT — The empty cabinet, at this time, should be positioned in the duct work with its transitions and connections caulked. Reinsert the after filter in the channel on the air leaving side. Slide the collecting cell into the cabinet so that the dirty air enters through the ionizing section (side with thin tungsten wires).

Before sliding the cell completely into the cabinet, insert the plastic thru bushing into the end plate hole adjacent to the ionizing bar with the ¼" terminal attached. Unplug the high voltage wire from the power pack. Run the wire thru the bushing and plug onto the ionizing bar terminal. Push the cell on into the cabinet.

Insert the rubber grommet in the hole of the access door on the same side of the cabinet as the high voltage wire. Insert the plastic plug in the remaining hole.

Reinsert the access door into the cabinet. Feed the high voltage wire thru the rubber grommet. Close Door.

Mounting the Power Pack to the Cabinet — The rear of the power pack housing is designed with two key hole slots that hook over round head machine screws mounted in the front of the cabinet. The cabinet door is furnished with a power pack clip. Remove the power pack lid by removing screw and lifting off lid. Insert bottom back of power pack into the clip before inserting the machine screws into the key hole slot.

After the power pack is hooked in place, fasten the two machine screws firmly securing the power pack to the cabinet. The clip prevents the power pack from being pulled away from the cabinet door.

Pull any excess high voltage wire thru the rubber grommet and plug wire onto power supply terminal marked "CELL". Replace the power pack cover.

(See back page for pictorial sketch)

2. Electrical Installation Between Power Pack and Air Handling Equipment's Fan Control on Heating or Cooling System

- The air cleaner must be wired through the air handling equipment's fan or blower control. The air cleaner must be wired to a 120 volt A.C., 60 cycle power supply.
- Install a grounded electrical junction box near the air cleaner so that the power cord from the power supply is of sufficient length to plug into the electrical junction box.
- From the air handling equipment's fan or blower control, route two electrical wires of sufficient rating to the added electrical junction box in accordance with the attached wiring diagrams.
- All electrical field wiring shall be in accordance with the national electrical code and/or local codes.

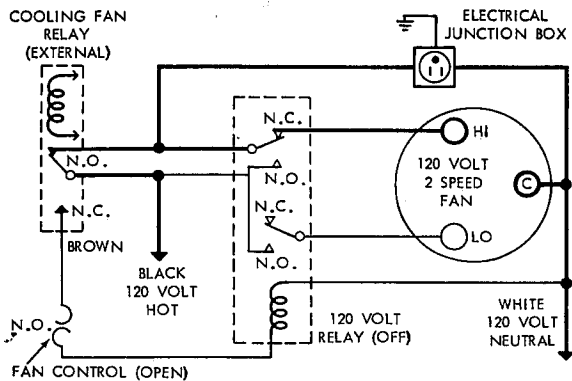

COOLING MODE – FAN OPERATING IN HI SPEED

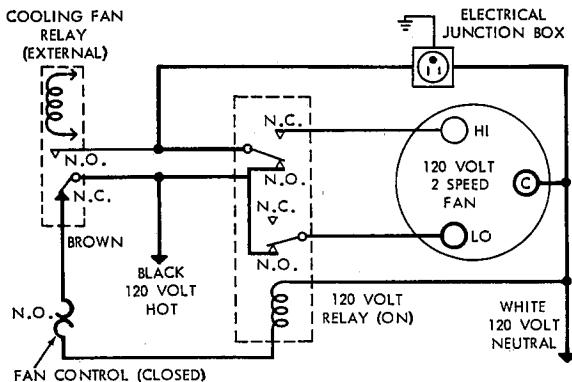

HEATING MODE – FAN OPERATING IN LOW SPEED

REMOTELY LOCATING THE POWER PACK – A special remote power pack kit is available for installations where the power pack is to be positioned in a location away from the air cleaner. The kit consists of a 15' length of high voltage wire and a safety switch box with mounting bracket.

The safety box protects from accidental shock. The 15' high voltage wire is connected to the remotely located power pack.

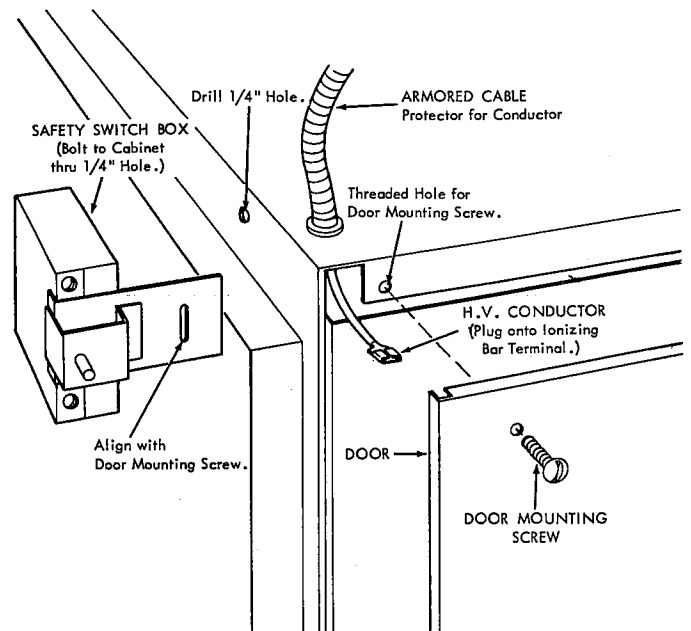

REMOTE POWER PACK CABINET CONNECTIONS

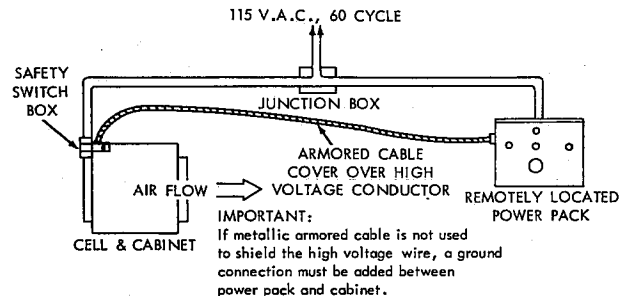

WIRING FOR REMOTE POWER PACK

FINAL CHECK-OUT

When the unit is totally assembled, the electrical and water connections should be checked in the following manner:

ELECTRIC – Turn the ON/OFF rocker switch ON. The indicating light on the front of the power pack should be lit, indicating that power is being supplied to the unit. If it is not, refer to the SERVICE section of this manual. Please note the air handling equipment fan or blower must also be ON for the air cleaner to work.

WATER – The wash cycle should be activated to determine that there are no leaks. Correct washing procedures are listed in the next section under OPERATION.

OLD MEDIA FILTER – If the present air handling equipment has a media filter, remove and discard.

SPRAY-KLEAN AND SPRAY-MATIC CONTROLS – These optional controls should be used according to the instructions supplied with their separate installation manuals, or inside their control box covers.

SERVICE PROCEDURES

WASHING THE COLLECTING CELL

Owner maintenance of the electronic air cleaner will insure maximum filtration at all times. The most important item is to clean the collecting cell at least once a month to wash away accumulated dirt particles. One of the advantages of Water Wash units is that the cell can be washed in its installed position.

This can be accomplished by a variety of methods, depending upon the cleaning process provided.

HAND VALVE — If the installation includes a hand valve in a hot waterline leading to the manifold protruding from the front of the electronic air cleaner, the following procedures should be used:

1. Push the air cleaner's ON/OFF rocker switch to OFF.
2. Turn the air handling system's fan off.
3. Unroll the plastic drain hose, connected to the bottom of the air cleaner cabinet, to the nearest floor drain. (omit this step if a permanent drain pipe has been installed.)
4. Turn the hot water hand valve full open, and allow to run for three minutes, or until the drain water is clear. Close the hand valve.
5. Wait two minutes to allow the cell to drip partially dry and turn the air handling system's fan on. Make sure the air cleaner's ON/OFF switch is still OFF.
6. Wait an additional 45 minutes, then turn the air cleaner's ON/OFF switch ON. If a slight arcing condition (loud cracking sounds) occurs, the cell is probably not completely dry. There will be no damage to the air cleaner if the arcing is permitted to continue and it will probably cease when the cell is completely dry. If the arcing seems excessive, allow the cell to dry an additional half hour.

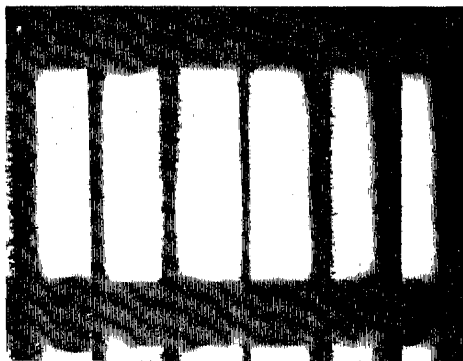

This picture clearly illustrates dirt particles adhering to the cell plates in an electronic-air cleaner, after two weeks of actual operation. Dirt particles, as small as 1/100 of a micron, receive an electrical charge as they enter the air cleaner's collecting cell. The charged particles cling to the cell's plates where they remain until the cell is washed during routine maintenance.

PERIODIC INSPECTION

Regardless of the method employed in washing the collecting cell in its installed position, the cell and after filter should be removed from the cabinet at least once a year and thoroughly washed with warm water and detergent to cleanse areas that may have been lightly cleaned by the fixed manifold.

Access to the cell is achieved by turning the power pack rocker switch to OFF, disconnecting the power cord and removing the power pack. The power pack is held in position by two machine screws that are inside the cabinet.

The mounting screws and high voltage wire must be disconnected before the power pack is removed.

The air cleaner's access door is lifted up and out, revealing the collecting cell and interior cabinet. (A shipping plate holding the cell may still be in position. Remove and discard.) The cell will now easily slide from the cabinet and the after filter can be lifted from its channel. Remove the high voltage wire from the cell.

Thoroughly clean both components, using a solution of low-sudsing dish washer detergent and warm water. Wipe each ionizing wire with a cloth to remove dirt particles that have collected on the wire. Reassemble unit and continue with monthly in-place washings for another year.

The electronic air cleaner is designed to give years of trouble-free operation. It is possible, however, that at some time the air cleaner may require some minor service. The indicating light, mounted on the front of the power pack, shows the homeowner that power is being supplied to the unit. An occasional flicker of the light accompanied by harmless sparking or snapping noise is normal. It is caused by trapping large particles of dirt. If arcing is continuous, the cell should be washed.

The chart printed below explains service check out procedures that can be performed by a heating and air conditioning contractor using a kilovoltmeter probe or OHM meter if power to the unit is available and the problem is a defective component.

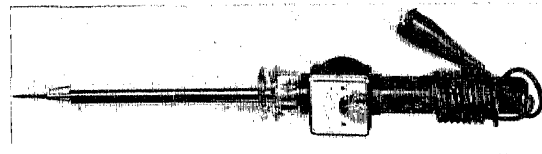

USING THE KILOVOLT METER

1. Attach ground clip on kilovoltmeter probe to power pack housing.
2. Energize power pack and read the voltage at the thru-bushing by touching the metal end of the probe to the wing nut on the thru-bushing.

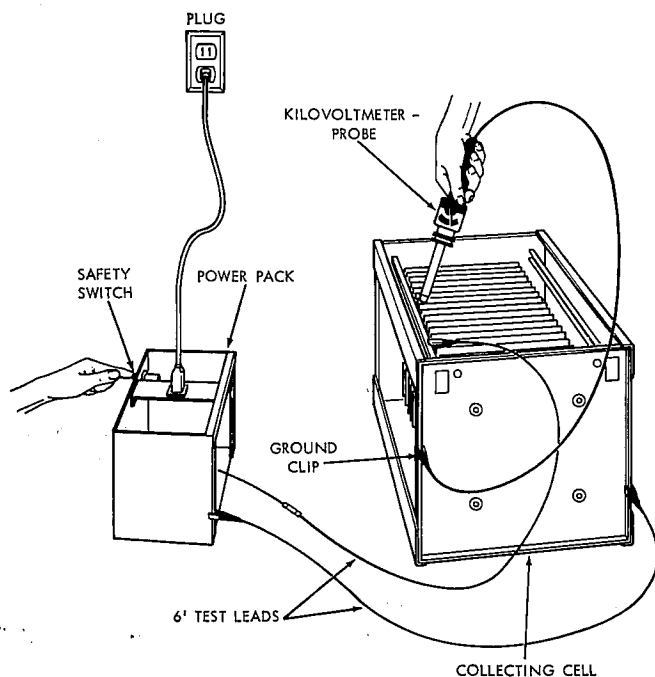

VOLTAGE READING	INDICATION
8000 ± 500 VDC	Unit operating correctly
Less than 7500 volts (DC) at collecting cell.	<ol style="list-style-type: none"> 1. Turn off power to power pack. 2. Using a plastic handled screw driver, ground power supply terminal marked "CELL" to cabinet. 3. Remove high voltage lead from power supply. 4. Turn on power to power pack. 5. Read voltage on kilovoltmeter by touching metal end of probe to terminal marked "CELL" on power supply.
8500 VDC or Higher	<p>Problem is located in cell.</p> <ol style="list-style-type: none"> 1. Ionizing wire may have collected dust particles, as such they must be wiped clean with a cloth.
Less than 8500 volts	<p>Problem is in power pack.</p> <ol style="list-style-type: none"> 1. Check voltage at power supply line terminals to ensure a nominal line voltage of approx. 115 VAC. 2. If voltage is adequate check voltage at terminal marked light (Do not disconnect lead). Voltage should be 60 VDC min. 3. If voltage at light terminal is adequate, replace operating light if light is out. 4. If voltage at light terminal is below 60 VAC, disconnect power supply from source of power. Check all terminals for tightness. 5. Measure resistance of primary coil by disconnecting the leads that go to the H.V. component board. Resistance should be 29 to 35 OHMS. 6. Measure resistance of secondary coil by disconnecting the leads that go to the H.V. component board. Resistance should be 8000 to 12,000 OHMS. 7. If resistance reading of either primary or secondary coil is below minimum replace transformer; if not replace H.V. component board. 8. An alternate check can be made as follows: with primary leads connected to component board, apply 120 VAC to line terminals and measure transformer output voltage on the secondary leads. If output is above 800 VAC replace H.V. component board. If output is below 800 VAC replace transformer.
4,000 VDC	Usually indicates a faulty capacitor or diode. Replace printed circuit board with components.
0 to 3,800 VDC 4,000 to 7,500 VDC	Usually indicates faulty transformer. Replace transformer.

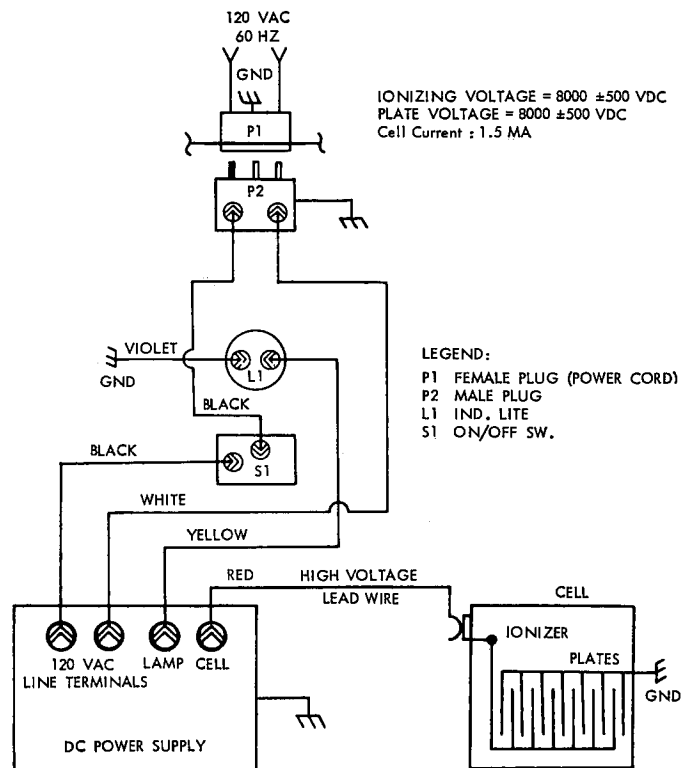

WIRING DIAGRAM

REPAIR PARTS

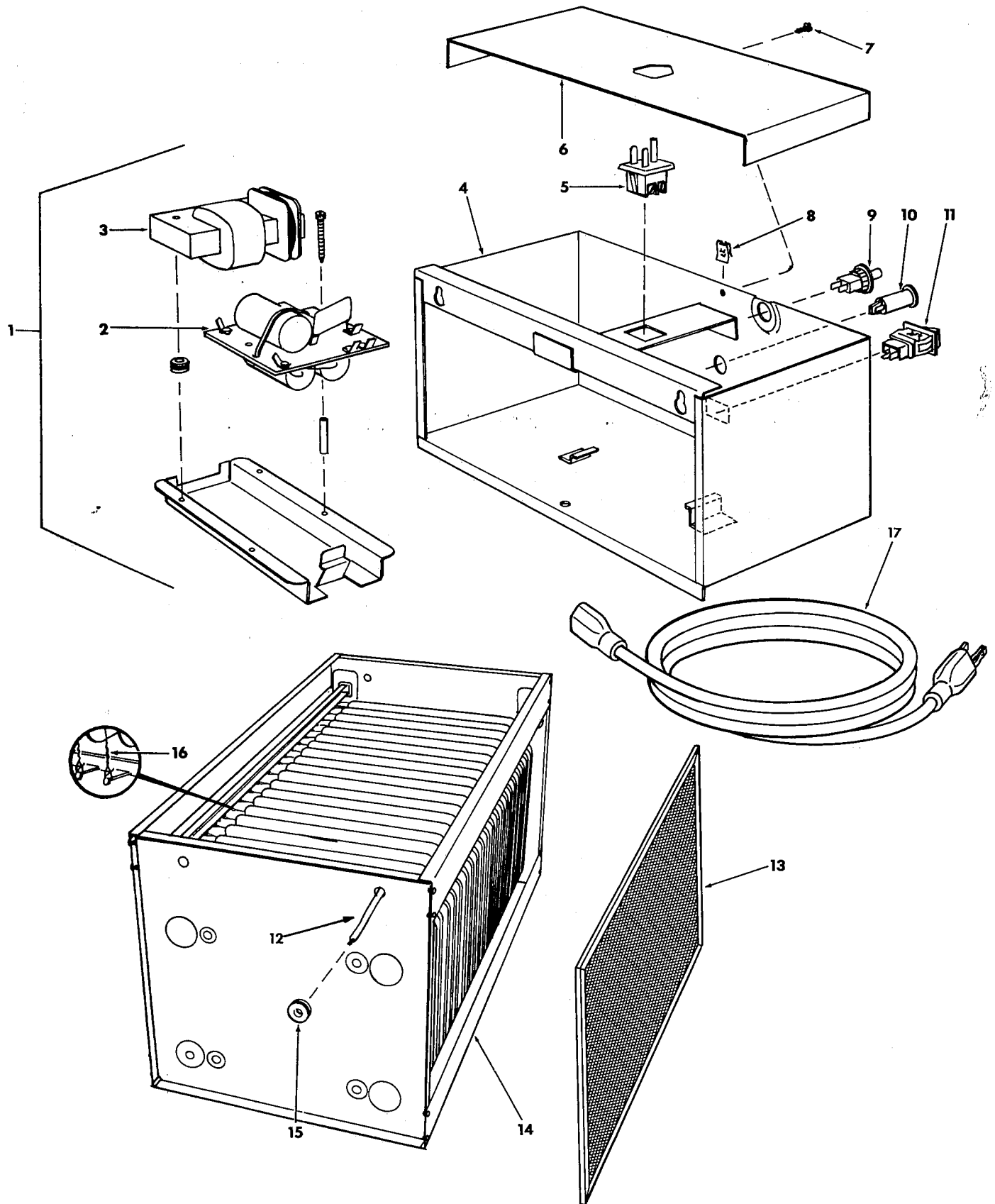

**REPLACEMENT PARTS FOR MODEL NO. 14C12H-01000, 14C12V-01000,
20C12H-01000 AND 20C12V-01000
ELECTRONIC AIR CLEANERS**

Item	Description	Usage	Part No.
1	Power Supply Assembly	All	F858-0475
2	Component Board	All	F859-0237
3	Transformer	All	F881-0192
4	Power Pack Enclosure	All	
5	Male Plug	All	F818-0038
6	Cover	All	
7	*Screw	All	
8	*Nut	All	
9	Safety Switch	All	F876-0118
10	Light	All	F844-0104
11	On-Off Switch	All	F876-0093
12	H.V. Lead Wire	All	F843-1021
13	After Filter	14C12H	F825-0133
	After Filter	14C12V	F825-0132
	After Filter	20C12H	F825-0135
	After Filter	20C12V	F825-0047
14	Collecting Cell	14C12H and 14C12V	F811-0309
	Collecting Cell	20C12H and 20C12V	F811-0310
15	Grommet	All	F888-0089
16	Ionizing Wire	All	F843-1020
17	Power Cord	All	F848-0128
**	Power Pack, Complete (Includes Items 1 thru 12)	All	F858-0469
**	Water Manifold	14C12H	F887-0014
**	Water Manifold	14C12V	F887-0015
**	Water Manifold	20C12H	F887-0016
**	Water Manifold	20C12V	F887-0017
**	Spray Nozzles	All	F821-0032
**	Plastic Drain Assembly	All	F801-0038
**	Plastic Drain Hose	All	F835-0010
**	Charcoal Filter (Replacement)	14C12H	F825-0106
**	Charcoal Filter (Replacement)	14C12V	F825-0107
**	Charcoal Filter (Replacement)	20C12H	F825-0108
**	Charcoal Filter (Replacement)	20C12V	F825-0109
**	Charcoal Filter w/adaptor	14C12H	F825-0069
**	Charcoal Filter w/adaptor	14C12V	F825-0057
**	Charcoal Filter w/adaptor	20C12H	F825-0059
**	Charcoal Filter w/adaptor	20C12V	F825-0061
**	Manual	All	846-0153

*Standard Hardware Item

**Not Shown

Electro-air®

WATER WASH ELECTRONIC AIR CLEANERS

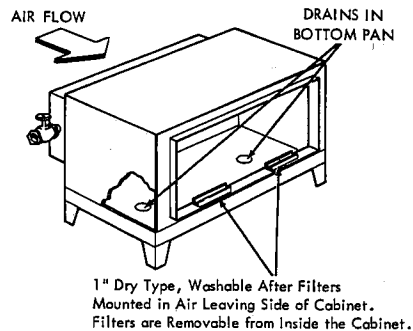
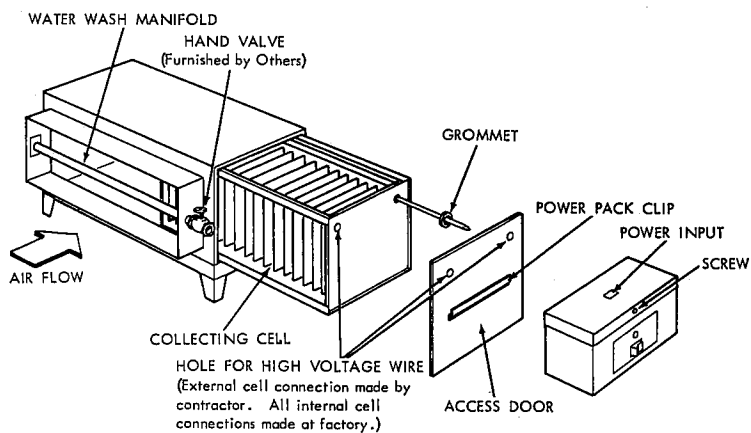
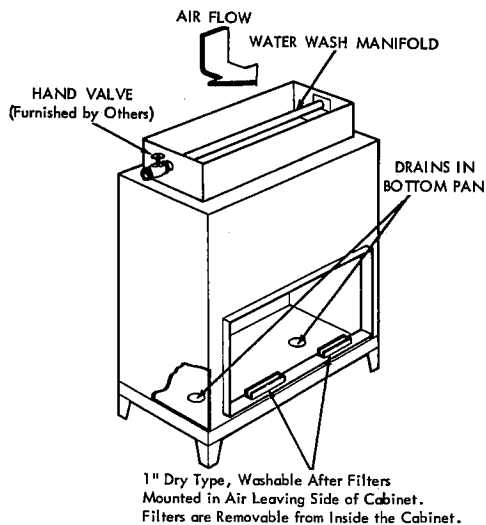
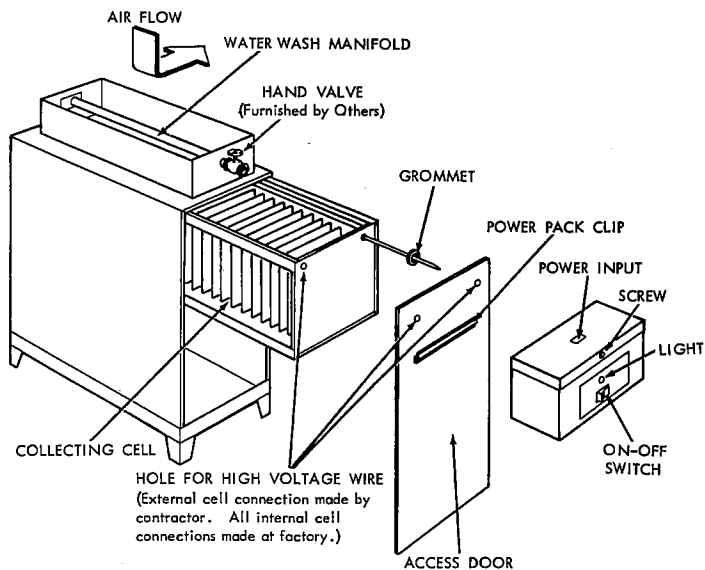

ELECTRO-AIR DIVISION
EMERSON ELECTRIC CO.
HARRISON, ARK. 72601