

HEAT CONTROLLER, INC.

Comfort-Aire®

Through-The-Wall Air Conditioner

MODELS: BGE-103A
BGE-123A

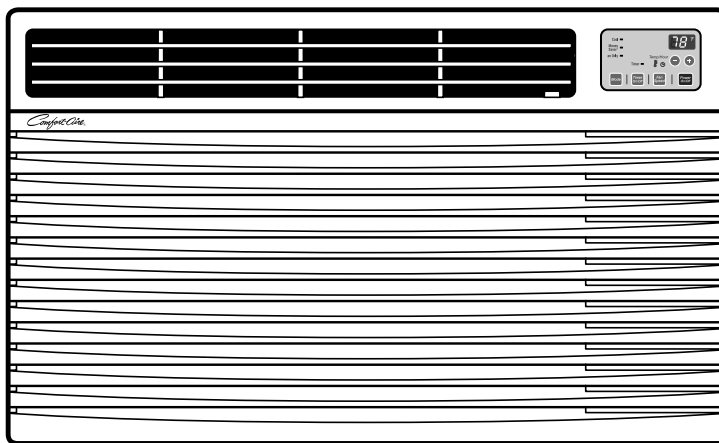

Service Manual

CAUTION

- Before servicing the unit, read the "safety precautions" in this manual.
- Only for authorized service personnel.

TABLE OF CONTENTS

Safety Precautions	3
Installation	7
Installation requirements	7
Installation	8
How to Install.....	8
Procedure A	9
Procedure B	11
Procedure C	12
Operating Instructions	14
Controls.....	14
Remote control.....	15
How to insert batteries	16
Ventilation Control	16
Air Direction.....	16
Disassembly instructions	17
Mechanical Parts.....	17
Air Handling Parts	18
Electrical Parts	19
Refrigeration Cycle.....	21
Schematic Diagram	24
Wiring Diagram.....	24
Troubleshooting Guide	25
Piping System	25
Troubleshooting Guide	26
Room Air Conditioner Voltage Limits.....	29
Product specifications	31
Exploded View	32
Replacement Parts List	33

Safety Precautions

To prevent injury to the user or other people and property damage, the following instructions must be followed.

- Incorrect operation due to ignoring instruction will cause harm or damage. The seriousness is classified by the following indications.

⚠ WARNING This symbol indicates the possibility of death or serious injury.

⚠ CAUTION This symbol indicates the possibility of injury or damage to property only.

- Meanings of symbols used in this manual are as shown below.

	Be sure not to do.
	Be sure to follow the instruction.

⚠ WARNING

■ Installation

Don't use a power cord, a plug or a loose socket which is damaged.

- Otherwise, it may cause a fire or electrical shock.

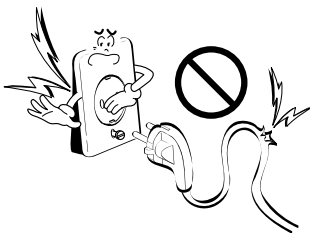

Always plug into a grounded outlet.

- Otherwise, it may cause a fire or electrical shock.

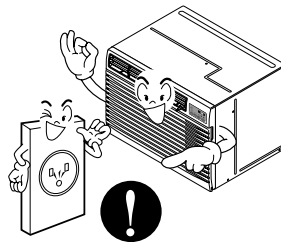

Do not modify or extend the power cord length.

- It will cause electric shock or fire due to heat generation.

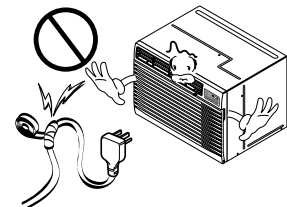

Do not disassemble or modify products.

- It may cause failure and electric shock.

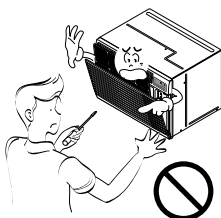

Be caution when unpacking and installing.

- Sharp edges may cause injury.

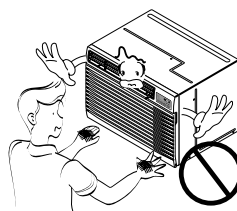

Do not use the power cord near flammable gas or combustibles such as gasoline, benzene, thinner, etc.

- It may cause explosion or fire.

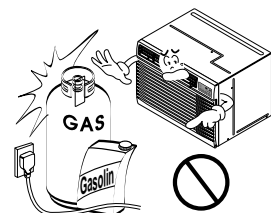

■ Operation

Do not place heavy object on the power cord and take care so that the cord should not be pressed.

- There is danger of fire or electric shock.

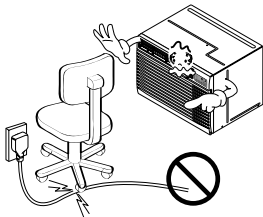

Do not place the power cord near a heater.

- It may cause fire and electric shock.

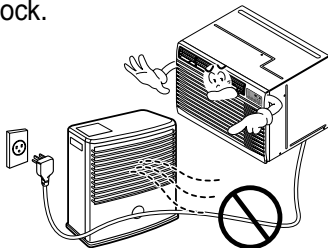

Unplug the unit if strange sounds, odors, or smoke come from it.

- Otherwise it may cause fire and electric shock accident.



Ventilate the room well when using this appliance together with a stove, etc.

- An oxygen shortage may occur.

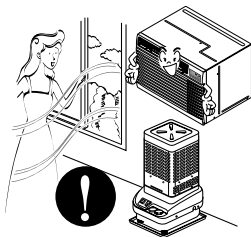

Do not share the outlet with other appliances.

- It will cause electric shock or fire due to heat generation.

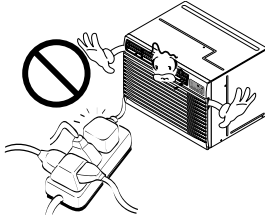

Do not allow water to run into electric parts.

- It will cause failure of machine or electric shock.

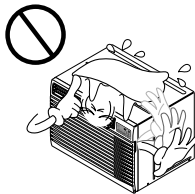

Do not open the suction inlet grill of the product during operation.

- Otherwise, it may electrical shock and failure.

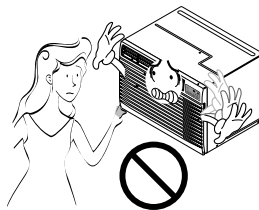

Turn off the power and breaker firstly when cleansing the unit.

- Since the fan rotates at high speed during operation, it may cause injury.

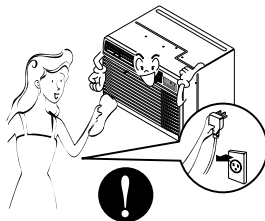

Take the power plug out if necessary, holding the head of the plug and do not touch it with wet hands.

- Otherwise, it may cause a fire or electrical shock.



Use a soft cloth to clean. Do not use wax, thinner, or a strong detergent.

- The appearance of the air conditioner may deteriorate, change color, or develop surface flaws.

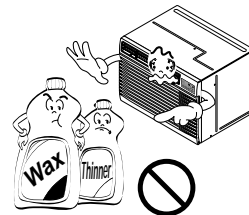

If water enters the product, turn off the the power switch of the main body of appliance. Contact service center after taking the power-plug out from the socket.



Turn off the main power switch when not using it for a long time.

- Prevent accidental startup and the possibility of injury.

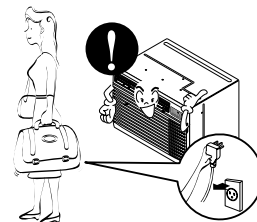

Do not operate or stop the unit by inserting or pulling out the power plug.

- It will cause electric shock or fire due to heat generation.

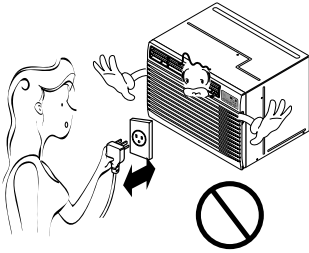

Do not damage or use an unspecified power cord.

- It will cause electric shock or fire.

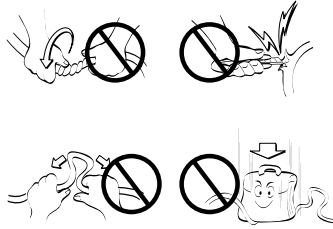

Do not operate with wet hands or in damp environment.

- It will cause electric shock.

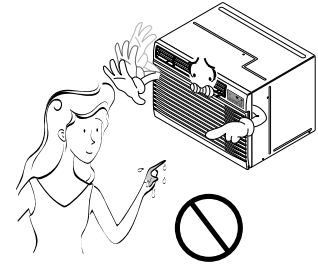

Hold the plug by the head when taking it out.

- It may cause electric shock and damage.

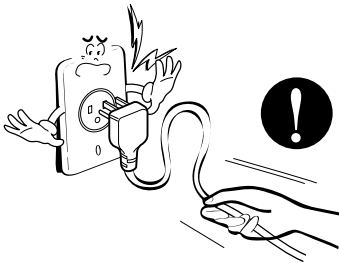

When gas leaks, open the window for ventilation before operating the unit.

- Otherwise, it may cause explosion, and a fire.

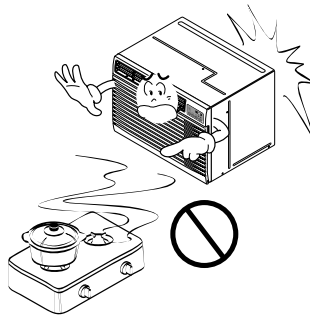

Never touch the metal parts of the unit when removing the filter.

- They are sharp and may cause injury.

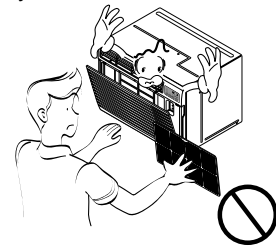

CAUTION

Installation

Install the product so that the noise or hot wind from the outdoor unit may not cause any damage to the neighbors.

- Otherwise, it may cause dispute with the neighbors.

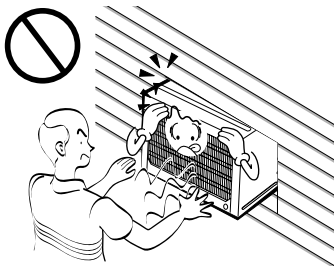

Keep level parallel in installing the product.

- Otherwise, it may cause vibration or water leakage.

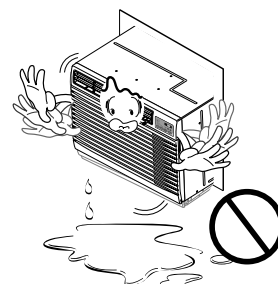

■ Operation

Do not put a pet or house plant where it will be exposed to direct air flow.

- It may cause injury.

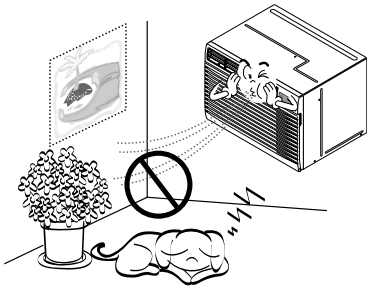

Do not block the inlet or outlet of air flow.

- It may cause product failure.

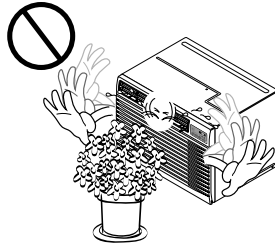

Use a soft cloth to clean. Do not use wax, thinner, or a strong detergent.

- The appearance of the air conditioner may deteriorate, change color, or develop surface flaws.

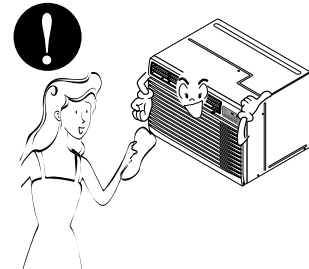

Do not step on the indoor/outdoor unit and do not put anything on it.

- It may cause an injury through dropping of the unit or falling down.

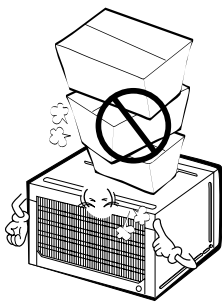

Always insert the filter securely. Clean it every two weeks.

- Operation without filters will cause failure.

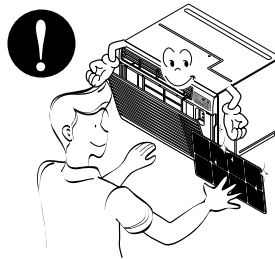

Do not drink water drained from air conditioner.

- It contains contaminants and will make you sick.

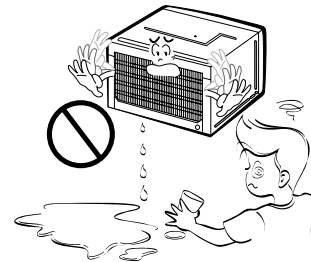

Be cautious not to touch the sharp edges when installing.

- It may cause injury.



Avoid excessive cooling and perform ventilation sometimes.

- Otherwise, it may do harm to your health.

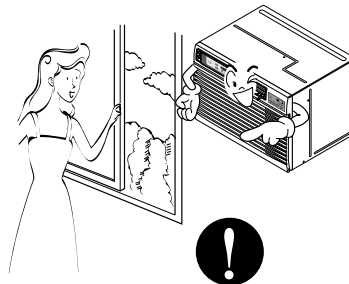

Do not insert the hands or bars through the air inlet or outlet during operation.

- Otherwise, it may cause personal injury.

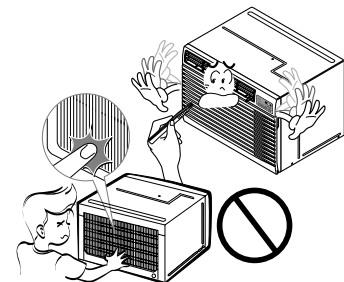

Installation

Remove packing sheet from the back of the sleeve, and packing corner and blue tape from the air conditioner.

Installation requirements

If you use an existing wall sleeve, you should measure its dimensions.

Install the new air conditioner according to these installation instructions to achieve the best performance. All wall sleeves used to mount the new air conditioner must be in good structural condition and have a rear grille to securely attach the new air conditioner. (FIG. 1)

With the LGE sleeve (optionally supplied with your unit), you can maintain the best performance of the new air conditioner. (FIG. 2)

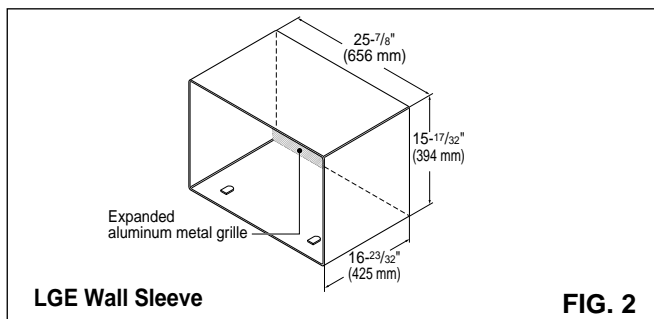
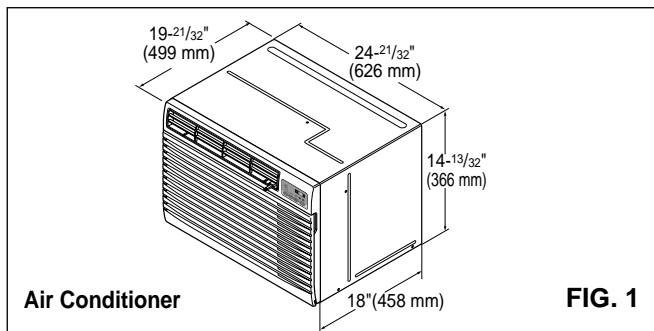

ELECTRICAL SERVICE

Check your available electrical service. The power supply available must be the same as that shown on the unit nameplate (found on left side of cabinet).

All models are equipped with a 3-prong service plug to provide proper service and safe positive grounding. Do not change plug in any way. Do not use an adapter plug. If your present wall outlet does not match your plug, call a qualified electrician to make the necessary corrections. SAVE CARTON for storage and this OWNER'S MANUAL for future reference. The carton is the best way to store unit during winter or when not in use.

INSTALLATION HARDWARE

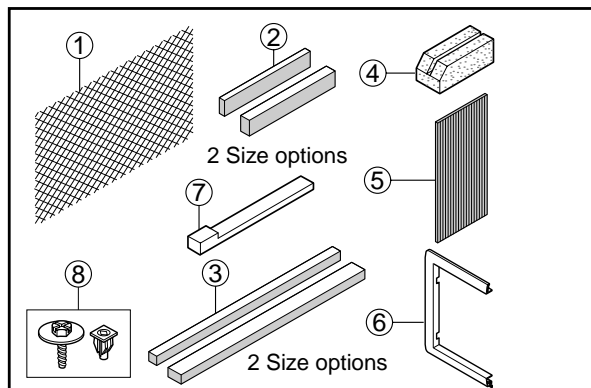

ITEM	NAME OF PARTS	Q' TY
①	PLASTIC GRILLE	1
②	HORIZONTAL INSULATION STRIPS	2
③	AROUND INSULATION STRIPS	2
④	SUPPORT BLOCK	2
⑤	BAFFLE	1
⑥	TRIM FRAME	2
⑦	SHIM	2
⑧	PLASTIC NUTS AND WASHER SCREWS	4

⚠ CAUTION

To avoid risk of personal injury, property damage, or product damage due to the weight of this device and sharp edges that may be exposed:

- Air conditioners covered in this manual pose an excessive weight hazard. Two or more people are needed to move and install the unit. To prevent injury or strain, use proper lifting and carrying techniques when moving unit.
- Carefully inspect location where air conditioner will be installed. Be sure it will support the weight of the unit over an extended period of time.
- Handle air conditioner with care. Wear protective gloves whenever lifting or carrying the unit. AVOID the sharp metal fins of front and rear coils.
- Make sure air conditioner does not fall during installation.

REQUIRED TOOLS:

- Tight Fitting gloves
- Standard screwdriver
- Phillips screwdriver
- Pliers
- Sharp knife
- 3/8-inch open end wrench or adjustable wrench
- 1/4-inch hex socket and ratchet
- Tape measure
- Electric drill
- 1/4-inch drill bit

Installation

⚠ CAUTION

We strongly recommend the removal of the old wall sleeve and the installation of a new LGE Wall Sleeve. If you decide to keep the existing wall sleeve, you have to redirect the louvers at the back of the wall sleeve illustration. The use of pliers is recommended. If you DO NOT redirect, you run the risk of poor performance or product failure. This is not covered under the terms of the LGE warranty.

- Pick a location which will allow the conditioned air to blow into the area you want. Good installation with special attention to the proper position of the unit will lessen the chance that service will be needed.

ITEMS IN INSTALLATION HARDWARE

You may not need all parts in the kit. Discard unused parts

ITEM (inches)		Qty.
Plastic grille	26 ³ / ₄ x 16 ¹ / ₂	1
Horizontal Insulation Strips	1 ³ / ₈ x 5 ⁸ / ₈ x 27 ³ / ₁₆	1
	1 ³ / ₈ x 1 ³ / ₈ x 27 ³ / ₁₆	1
Around Insulation Strips	1 ³ / ₈ x 3 ⁴ / ₄ x 61 ¹ / ₂	1
	1 ³ / ₈ x 1 ³ / ₈ x 61 ¹ / ₂	1
Support Block	1 ³ / ₄ x 1 ³ / ₈ x 45 ¹ / ₁₆	2
Baffle	14 x 4 ¹ / ₂ x 1 ⁸ / ₈	1
Shim	13 x 1 x 3 ⁴ / ₄	2
Trim Frame		2
Washer Screw		4
Nuts(Plastic)		4

How to Install

1. Identify the existing wall sleeve before installing the unit from the listed below.

Brand	Wall Sleeve Dimensions (inches)		
	Width	Height	Depth
White-Westinghouse Frigidaire Carrier (52F series)	25-1/2	15-1/4	16, 17-1/2 or 22
General Electric /Hotpoint	26	15-5/8	16-7/8
Whirlpool	25-7/8	16-1/2	17-1/8 or 23
Fedders/Emerson	27	16-3/4	16-3/4 or 19-3/4
LGE	25-7/8	15-17/32	16-23/32
Emerson/Fedders	26-3/4	15-3/4	15
Carrier (51S Series)	25-3/4	16-7/8	18-5/8
Friedrich	27	16-3/4	16-3/4

NOTICE

All wall sleeves used to mount the new Air Conditioner must be in sound structural condition and have a rear grille that securely attaches to sleeve, or rear flange that serves as a stop for the Air Conditioner,

2. Remove old air conditioner from existing wall sleeve.
3. Clean the interior of an existing sleeve. (Do not disturb seals.)
4. Wall sleeve must be securely fastened in wall before installing the air conditioner. Use the nails or screws through sleeve into wall, if needed. Repair sleeve if needed.
5. Prepare the wall sleeve for installation of the unit. If you plan to use your existing wall sleeve, and it is not LGE, use procedure B or C below.

Procedure	Brand	Depth(inches)
A	LGE	16-23/32
B	White-Westinghouse Frigidaire Carrier (52F series)	16, 17-1/2 or 22
	General Electric /Hotpoint	16-7/8
	Whirlpool	17-1/8 or 23
	Carrier (51S series)	18-5/8
C	Fedders/Emerson	16-3/4 or 19-3/4
	Emerson/Fedders	15
	Friedrich	16-3/4

6. Install new unit into wall sleeve.

⚠ CAUTION

When installation is completed, replacement unit MUST have a rearward slope as shown. To achieve 1/4" slope, remove the backing from the 11-13/16" shim strips and attach them as shown below in Fig. 3. Place the higher portion of shim to the front of the rib on base of wall sleeve.

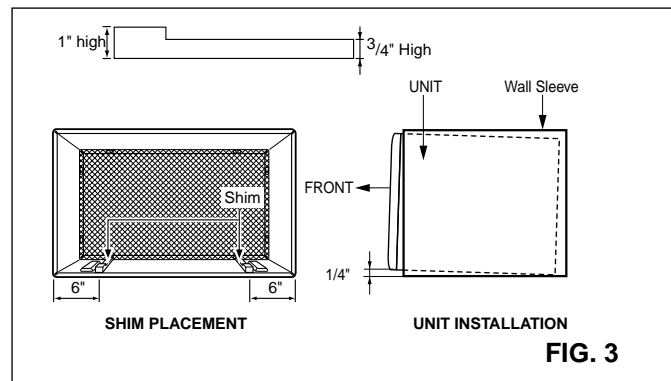

Procedure A

1. If you are using the new sleeve (optionally supplied with your unit), skip to step 3. Otherwise, install the plastic grille from the kit. Cut the plastic grille to 25-1/2" wide and 15-1/4" high. Place the plastic grille to the inside of the wall sleeve at the rear flange.

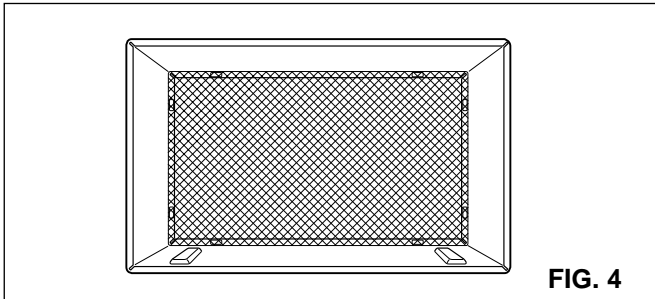

FIG. 4

2. Fasten the 4 washer screws to secure the grille to the wall sleeve. If you need plastic nuts to mount plastic grille to the inside of the wall sleeve, there are plastic nuts in the installation kit. The nuts are installed from the inside of the sleeve and are pressed into the square holes of the rear flanges.

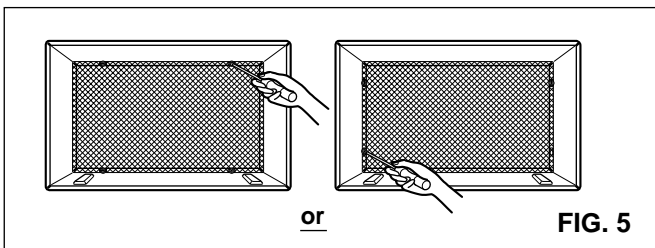

FIG. 5

3. Remove the backing from the Horizontal Insulation strip $1\frac{3}{8} \times \frac{3}{8} \times 27\frac{3}{16}$ and attach that to the inside bottom of the sleeve as shown below. Remove the backing from the Around Insulation strip $1\frac{3}{8} \times \frac{3}{4} \times 61\frac{1}{2}$ and attach that to the inside front of the sleeve as shown below.

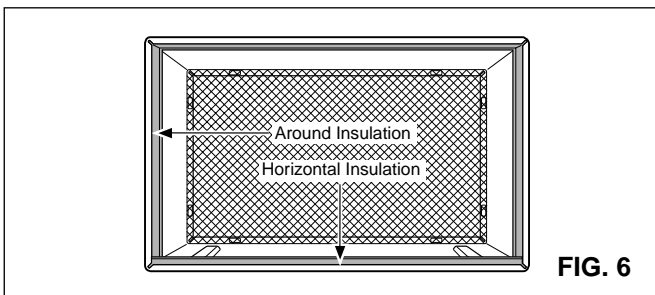

FIG. 6

4. Install the new unit into the wall sleeve.

5. To assemble trim, snap the tab of each piece into the slot of the other piece as shown below. Slide trim over the front of the air conditioner until trim is flush with sleeve as shown below.

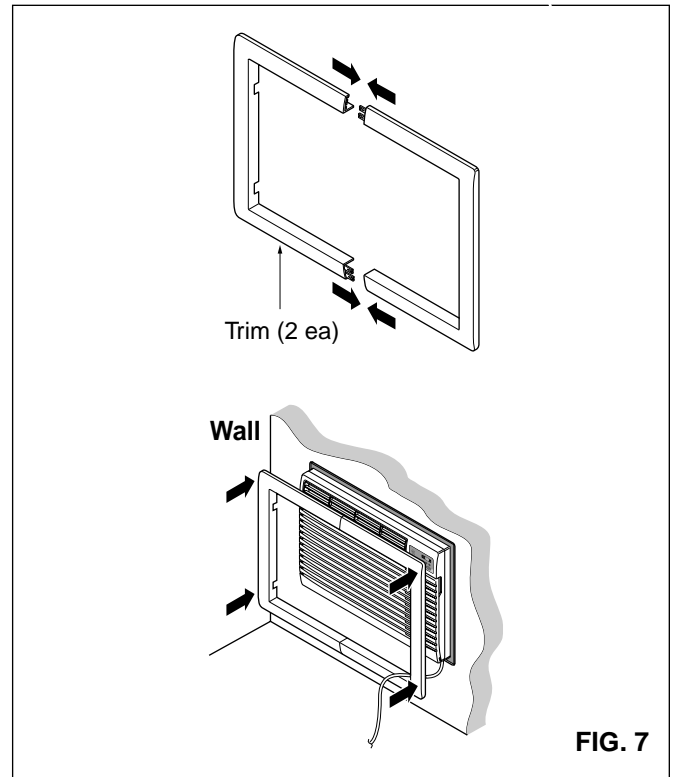

FIG. 7

CAUTION

- Air conditioners covered in this manual pose an excessive weight hazard. Two or more people are needed to move and install the unit. To prevent injury or strain, use proper lifting and carrying techniques when moving unit.
- When handling the air conditioner, be careful to avoid cuts from sharp metal fins on front and rear coils.
- Make sure air conditioner does not fall during removal.

Procedure B

1. Redirect the louvers at the back of the wall sleeve to 60° angle as shown in the FIG 8. The use of pliers is recommended.

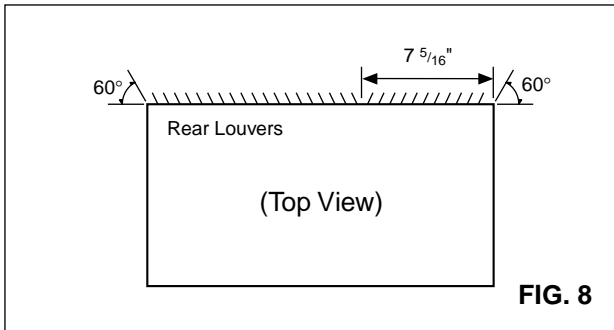

2. If the wall sleeve already has a rear grille, skip to step 4. If the wall sleeve does not have a rear grille or louvered panel, install the plastic grille from the kit. Cut the plastic grille to 25-1/2" wide and 15-1/4" high. Place the plastic grille to the inside of the wall sleeve at the rear flange.

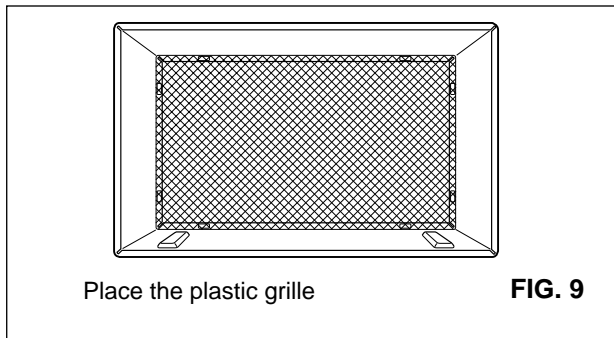

3. Fasten the 4 washer screws to secure the grille to the wall sleeve. If you need plastic nuts to mount plastic grille to the inside of the wall sleeve, there are plastic nuts in the installation kit. The nuts are installed from the inside of the sleeve and are pressed into the square holes of the rear flanges.

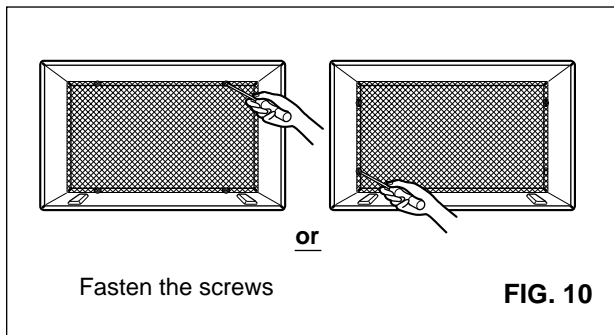

4. Remove the backing from the Horizontal Insulation strip $1\frac{3}{8} \times \frac{5}{8} \times 27\frac{3}{16}$ and attach that to the inside bottom of the sleeve as shown below. Remove the backing from the Around Insulation strip $1\frac{3}{8} \times \frac{3}{4} \times 61\frac{1}{2}$ and attach that to the inside front of the sleeve as shown below.

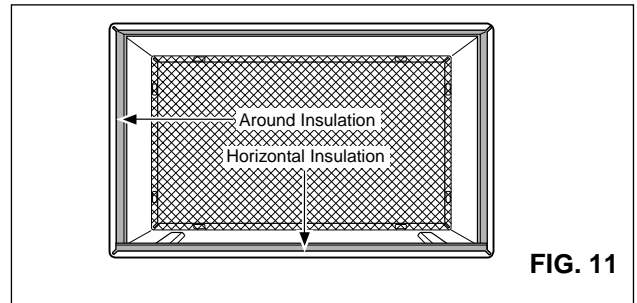

5. If the depth of your existing wall sleeve is less than or equal to 18", skip to step 6. Otherwise, cut the baffles and the support blocks according to length "A" in the table below.

Depth "D" of the existing wall sleeve (inches)	Length "A" (inches)
$18 < D \leq 18\text{-}\frac{5}{8}$	$\frac{3}{4}$
$18\text{-}\frac{5}{8} < D \leq 19\text{-}\frac{3}{4}$	$1\text{-}\frac{3}{4}$
$19\text{-}\frac{3}{4} < D \leq 22$	4

FIG. 12

6. Remove the backing from the support blocks and attach them to the inside of the wall sleeve as shown FIG 13. Slide the baffle into slots of the support blocks.

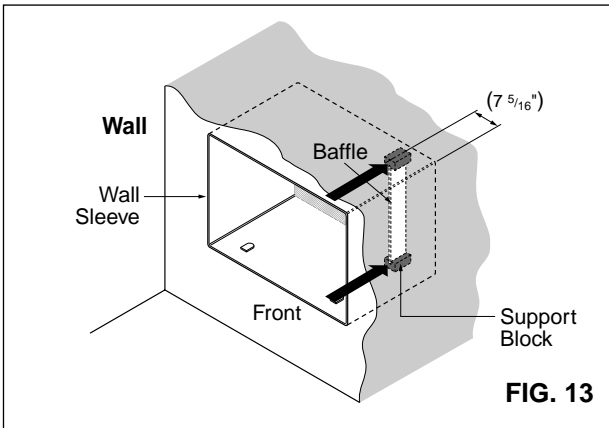

7. Install the new unit into the wall sleeve.

8. To assemble trim, snap the tab of each piece into the slot of the other piece as shown below. Slide trim over the front of the air conditioner until trim is flush with sleeve as shown below.

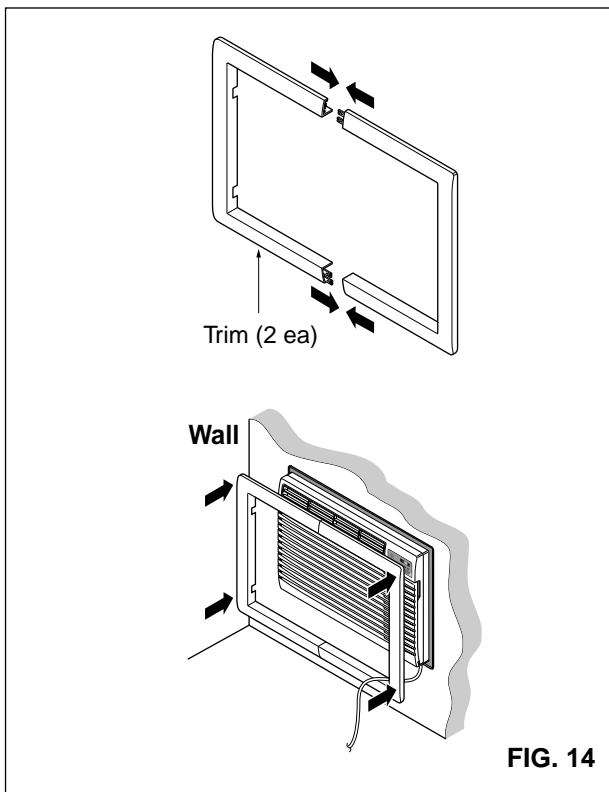

⚠ CAUTION

- Air conditioners covered in this manual pose an excessive weight hazard. Two or more people are needed to move and install the unit. To prevent injury or strain, use proper lifting and carrying techniques when moving unit.
- When handling the air conditioner, be careful to avoid cuts from sharp metal fins on front and rear coils.
- Make sure air conditioner does not fall during removal.

Procedure C

1. Redirect the louvers at the back of the wall sleeve to 60° angle as shown in the FIG 15. The use of pliers is recommended.

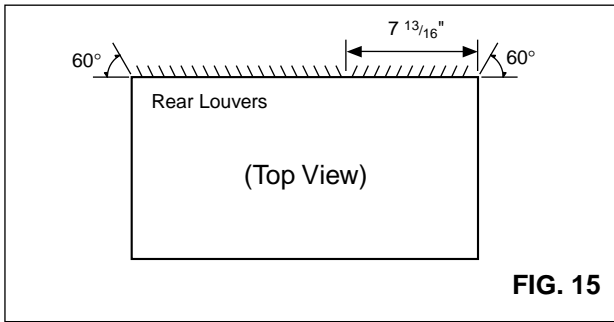

FIG. 15

2. If the wall sleeve already has a rear grille, skip to step 4. If the wall sleeve does not have a rear grille or louvered panel, install the plastic grille from the kit. Cut the plastic grille to 26-1/2" wide and 15-1/2" high. Place the plastic grille to the inside of the wall sleeve at the rear flange.

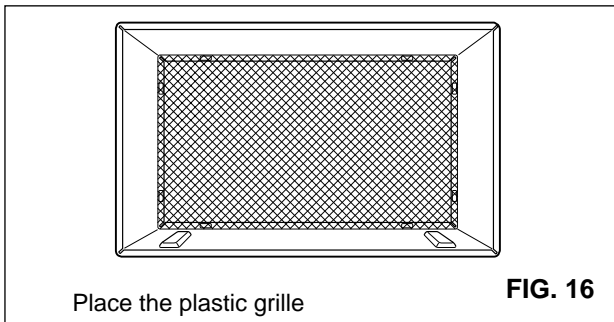

FIG. 16

3. Fasten the 4 washer screws to secure the grille to the wall sleeve. If you need plastic nuts to mount plastic grille to the inside of the wall sleeve, there are plastic nuts in the installation kit. The nuts are installed from the inside of the sleeve and are pressed into the square holes of the rear flanges.

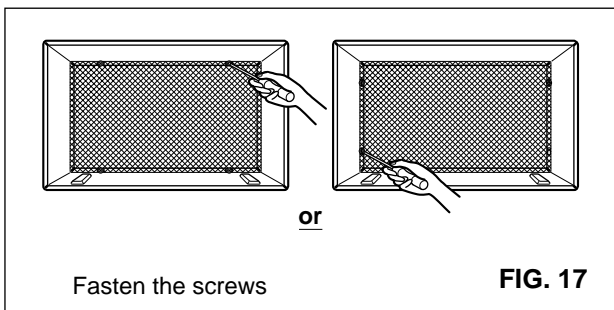

FIG. 17

4. Remove the backing from the Horizontal Insulation strip 1 3/8 x 1 3/8 x 27 3/16 and attach that to the inside bottom of the sleeve as shown below. Remove the backing from the Around Insulation strip 1 3/8 x 1 3/8 x 61 1/2 and attach that to the inside front of the sleeve as shown below.

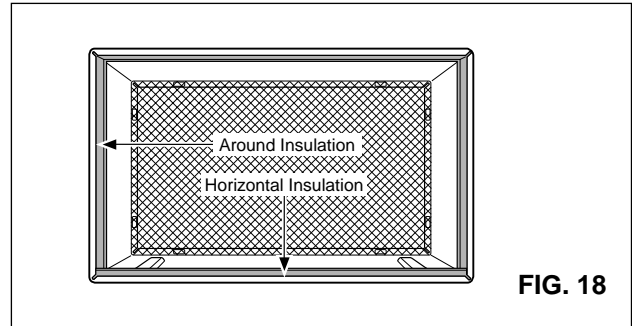

FIG. 18

5. If the depth of your existing sleeve is less than or equal to 18", skip to step 7. Otherwise, cut the baffles and the support blocks according to Length "A" in the table below.

Depth "D" of the existing wall sleeve (inches)	Length "A" (inches)
18 < D ≤ 18-5/8	3/4
18-5/8 < D ≤ 19-3/4	1-3/4
19-3/4 < D ≤ 22	4

FIG. 19

6. Remove the backing from the support blocks and attach them to the inside of the wall sleeve as shown FIG 20. Slide the baffle into slots of the support blocks

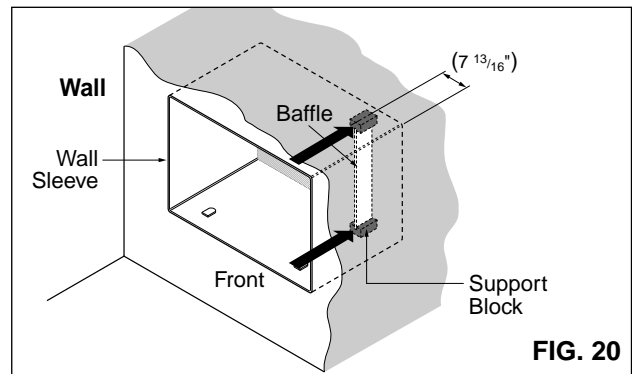
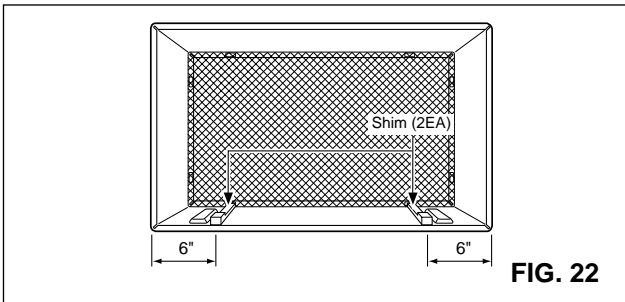
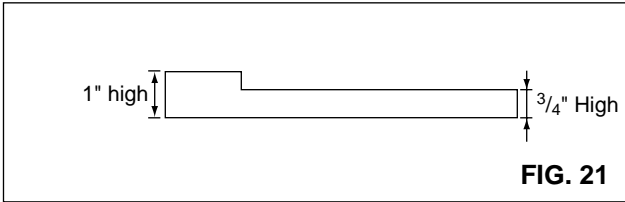

FIG. 20

7. Remove the backing from the 13" shim strips and attach them as shown below in Fig. 22. The higher portion of shim is to be placed in front of the rib on the base of wall sleeve.



8. Install the new unit into the wall sleeve

9. To assemble trim, snap the tab of each piece into the slot of the other piece as shown below. Slide trim over the front of the air conditioner until trim is flush with sleeve as shown below.

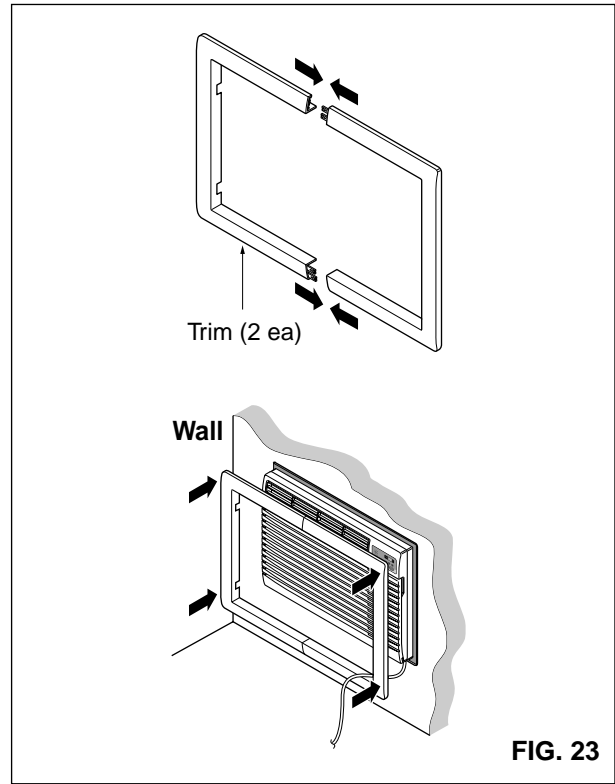

▲ CAUTION

- Air conditioners covered in this manual pose an excessive weight hazard. Two or more people are needed to move and install the unit. To prevent injury or strain, use proper lifting and carrying techniques when moving unit.
- When handling the air conditioner, be careful to avoid cuts from sharp metal fins on front and rear coils.
- Make sure air conditioner does not fall during removal.

Operating Instructions

Controls

The controls will look like one of the following.

FAN SPEED

- Every time you push this button, it advances the setting as follows: {High[F2] → Low[F1] → High[F2]}

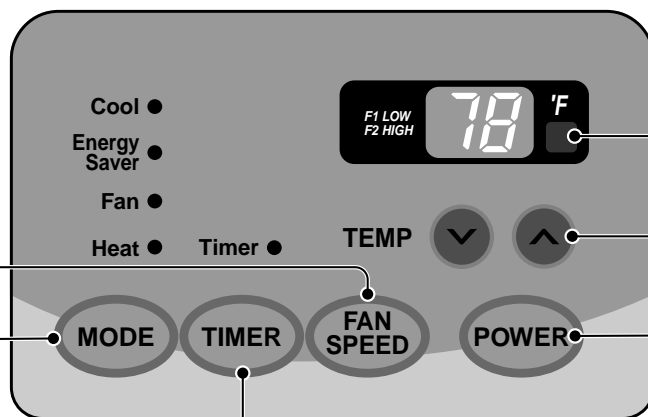

REMOTE CONTROL SIGNAL RECEIVER

TEMPERATURE SETTING

- Use this button to automatically control the temperature of the room.
The temperature can be set within a range of 60°F to 86°F by increments of 1°F.
- The setting appears in the display.

POWER

- To turn the air conditioner ON, push this button.
To turn the air conditioner OFF, push the button again.
- This button takes priority over any other button.

TIMER

- SHUT-OFF TIME

- You will usually use shut-off time while you sleep.
- If unit is running, use Timer to set number of hours until shut-off.
- For your sleeping comfort, once Time is set, the Temperature setting will raise 2°F after 30 min., and once again after another 30 min.
- Push Timer button to advance setting from 1Hour → 2Hours → ... → 12Hours maximum.

- START TIME

- If unit is off, use Timer to set number of hours before unit starts.
- Push Timer button to advance setting from 1Hour → 2Hours → ... → 12Hours maximum.

MODE

- Push this button to shift mode of operation from COOL → ENERGY SAVER → FAN → HEAT

- COOL:

- Fan runs continually for normal cooling operation.

- ENERGY SAVER:

- The fan stops when the compressor stops cooling. Approximately every 3 minutes the fan will turn on and the unit will check the room air temperature to determine if cooling is needed.

- FAN:

- Fan-only operation.

- HEAT:

- Fan runs continually for normal heating operation.

AUTO RESTART

When power is restored after an electrical power failure, the unit will begin to run at its last setting.

Remote control

The remote control and control panel will look like one of the following pictures.

POWER

- To turn the air conditioner ON, push this button.
- To turn the air conditioner OFF, push the button again.
- This button takes priority over any other button.

TEMPERATURE SETTING

- Use this button to automatically control the temperature of the room. The temperature can be set within a range of 60°F to 86°F by increments of 1°F.
- The setting appears in the display.

FAN SPEED

- Every time you push this button it advances the setting as follows: {High[F2] → Low[F1] → High[F2]}

TIMER

- SHUT-OFF TIME

- You will usually use shut-off time while you sleep.
- If unit is running, use Timer to set number of hours until shut-off.
- For your sleeping comfort, once Time is set, the Temperature setting will raise 2°F after 30 min, and once again after another 30 min.
- Push Timer button to advance setting from 1Hour → 2Hours → ... → 12Hours maximum.

- START TIME

- If unit is off, use Timer to set of hours before unit starts.
- Push Timer button to advance setting from 1Hour → 2Hours → ... → 12Hours maximum.

MODE

- Push this button to shift mode of operation from COOL → ENERGY SAVER → FAN → Heat.

- COOL:

- Fan runs continually for normal cooling operation.

- ENERGY SAVER:

- The fan stops when the compressor stops cooling. Approximately every 3 minutes the fan will turn on and the unit will check the room air temperature to determine if cooling is needed.

- FAN:

- Fan-only operation.

- HEAT:

- Fan runs continually for normal heating operation.

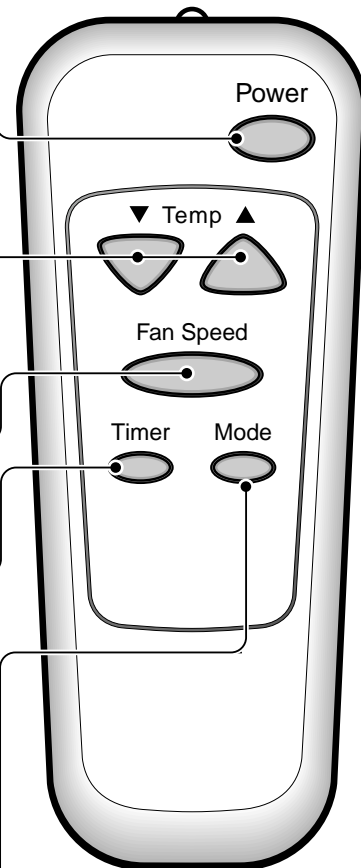

⚠ CAUTION

When the air conditioner has been performed its cooling or heating operation and is turned off or set to the fan position, wait at least 3 minutes before resetting to the cooling operation again.

A slight heat odor may come from the unit when first switching to HEAT after the cooling season is over. This odor, caused by fine dust particles on the heater, will disappear quickly. This is harmless.

How to insert Batteries

1. Remove the cover from the back of the remote controller.
2. Insert two batteries.
 - Be sure that the (+) and (-) directions are correct.
 - Be sure that both batteries are new.
3. Re-attach the cover.

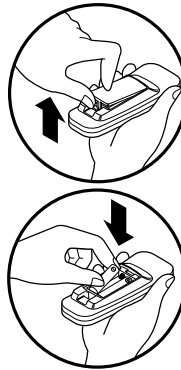

- Do not use rechargeable batteries. Such batteries differ from standard dry cells in shape, dimensions, and performance.
- Remove the batteries from the remote controller if the air conditioner is not going to be used for an extended length of time.

Ventilation Control

Push the lever to the "CLOSE" position to cool, heat or recirculate room air only.

Pull the lever to the "OPEN" position to exhaust smoke or stale air from the room.

This feature is best used in conjunction with the FAN ONLY position.

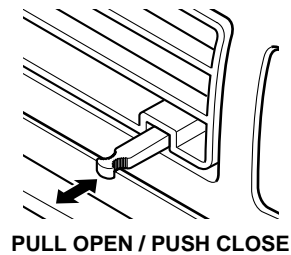

Air Direction

The direction of air can be controlled by adjusting the horizontal and vertical louvers.

• HORIZONTAL AIR-DIRECTION CONTROL

The horizontal air direction is adjusted by moving the vertical louver. The lever for the vertical louver is located in the right and left side of the air discharge.

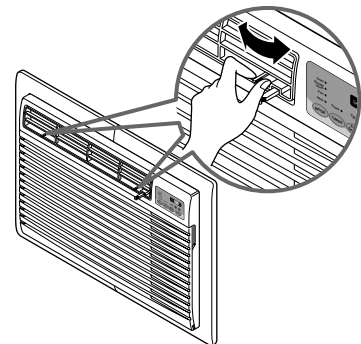

• VERTICAL AIR-DIRECTION CONTROL

The vertical air direction is adjusted by moving the horizontal louver.

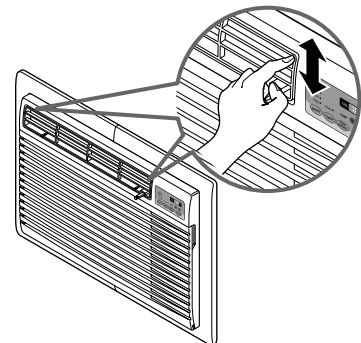

Disassembly Instructions

— Before the following disassembly, POWER SWITCH is set to OFF and disconnected the power cord.

Mechanical Parts

1. FRONT GRILLE

1. Open the inlet grille upward or downward.
2. Remove the screw which fastens the front grille.
3. Pull the front grille from the right side.
4. Remove the front grille. (See Fig. 24)
5. Re-install the component by referring to the removal procedure.

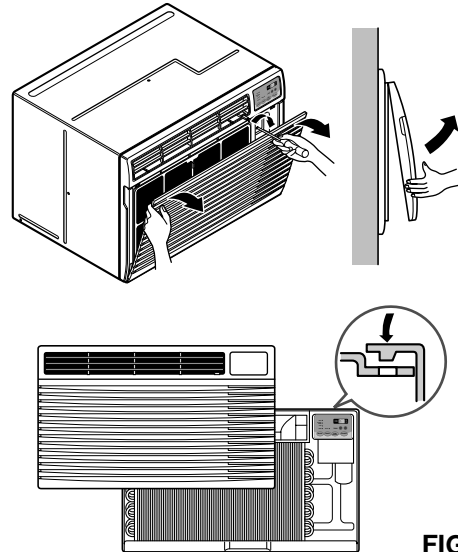

FIG. 24

2. CABINET

1. After disassembling the FRONT GRILLE, remove the 9 screws which fasten the cabinet at the both sides and the top. (See Fig. 25)
Keep these for later use.

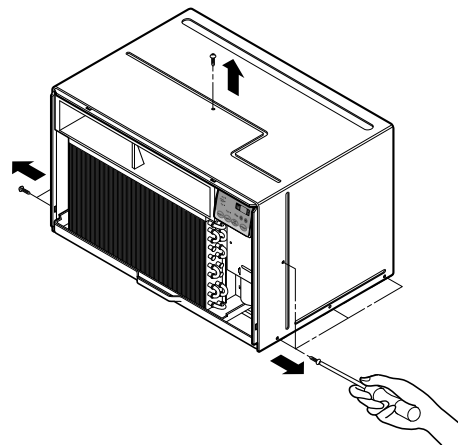

FIG. 25

3. CONTROL BOX

1. Remove the front grille. (Refer to section 1)
2. Remove the screw which fasten the control box. (See Fig. 26)
3. Pull the control box from the barrier. (See Fig. 26)
4. Discharge the capacitor by placing a 20,000 ohm resistor across the capacitor terminals.
5. Disconnect two wire housings in the control box.
6. Pull the control box forward completely.
7. Re-install the components by referring to the removal procedure. (See Fig. 26)
(Refer to the circuit diagram found on pages 24 in this manual and on the control box.)

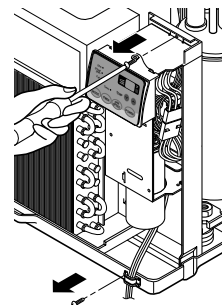

FIG. 26

Air Handling Parts

4. ORIFICE, HEATER ASSY AND TURBO FAN

1. Remove the front grille. (Refer to section 1)
2. Remove the cabinet. (Refer to section 2)
3. Remove the 2 screws which fasten the evaporator at the left side and the right side. (See Fig. 27)
4. Move the evaporator sideward carefully.
5. Remove the 2 terminals carefully (See Fig. 28, at Electric Heater Model only)
6. Remove the 4 screws which fasten the orifice. (See Fig. 28)
7. Remove the orifice. (See Fig. 28)

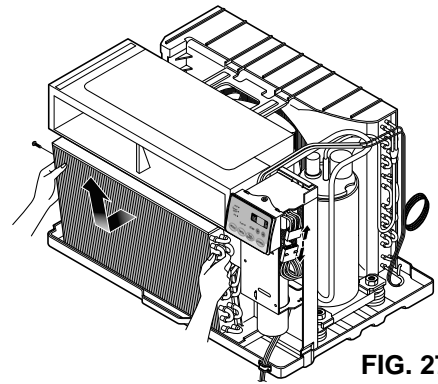

FIG. 27

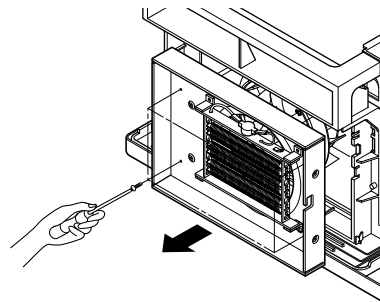

FIG. 28

8. Remove the clamp which secures the turbo fan with plier. (See Fig. 29)

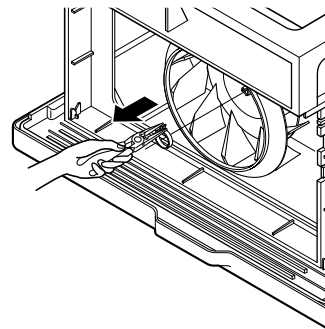

FIG. 29

9. Remove the turbo fan with plier or your hand without touching blades. (See Fig. 30)
10. Re-install the components by referring to the removal procedure, above.

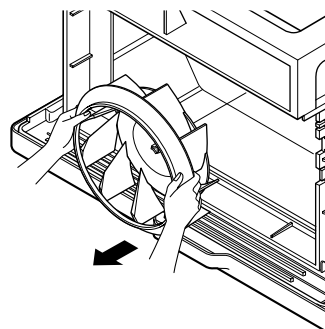

FIG. 30

5. FAN

1. Remove the cabinet. (Refer to section 2)
2. Remove the brace and shroud cover. (Refer to section 4)
3. Remove the 6 screws which fasten the condenser.
4. Move the condenser sideways carefully.
5. Remove the clamp which secures the fan.
6. Remove the fan. (See Fig. 31)
7. Re-install the components by referring to the removal procedure, above.

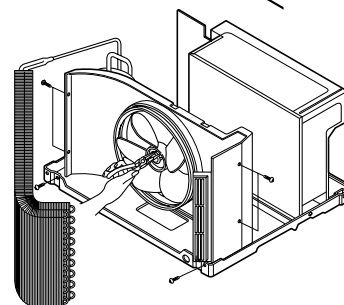

FIG. 31

6. SHROUD

1. Remove the fan. (Refer to section 5)
2. Remove the screw which fasten the shroud.
3. Remove the shroud. (See Fig. 32)
4. Re-install the component by referring to the removal procedure, above.

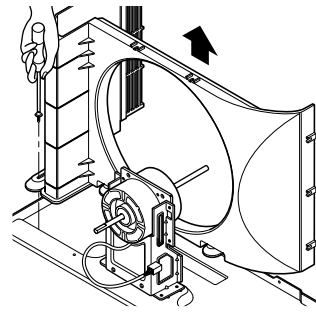

FIG. 32

Electrical Parts

7. MOTOR

1. Remove the cabinet. (Refer to section 2)
2. Remove the clamp cord and disconnect a wire housing in control box. (Refer to section 3)
3. Remove the turbo fan. (Refer to section 5)
4. Remove the fan. (Refer to section 5)
5. Remove the 4 or 2 screws which fasten the motor. (See Fig. 33)
6. Remove the motor.
7. Re-install the components by referring to the removal procedure, above.

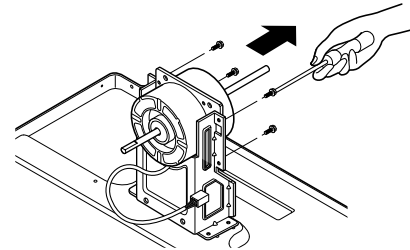

FIG. 33

8. COMPRESSOR

1. Remove the cabinet. (Refer to section 2)
2. Discharge the refrigerant system using Freon™ Recovery System.
If there is no valve to attach the recovery system, install one (such as a WATCO A-1) before venting the Freon™. Leave the valve in place after servicing the system.
3. Disconnect the 3 leads from the compressor.
4. After purging the unit completely, unbraid the suction and discharge tubes at the compressor connections.
5. Remove the 3 nuts and the 3 washers which fasten the compressor. (See Fig. 34)
6. Remove the compressor.
7. Re-install the components by referring to the removal procedure, above.

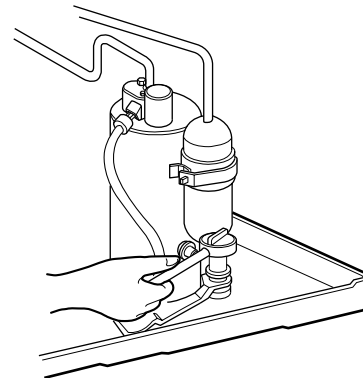

FIG. 34

9. CAPACITOR

1. Remove the control box. (Refer to section 3)
2. Remove a screw which fasten the display panel.
3. Remove 2 screws and unfold the control box. (See Fig. 35)
4. Remove the screw and the clamp which fastens the capacitor. (See Fig. 35)
5. Disconnect all the leads of capacitor terminals.
6. Re-install the components by referring to the removal procedure, above.

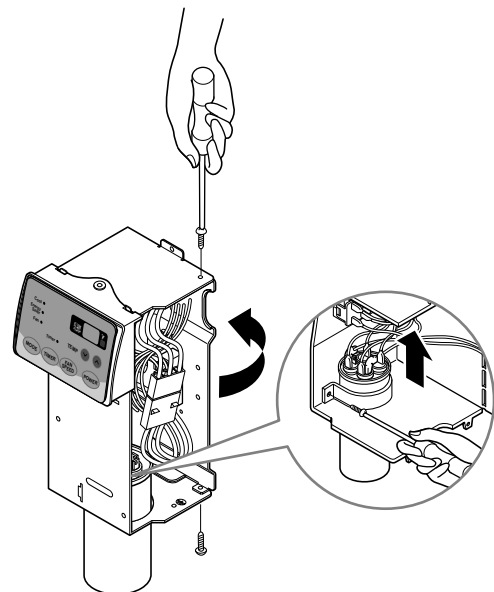

FIG. 35

10. POWER CORD

1. Remove the control box. (Refer to section 3)
2. Unfold the control box. (Refer to section 9)
3. Disconnect the grounding screw from the control box.
4. Disconnect 2 receptacles.
5. Remove a screw which fastens the clip cord.
6. Pull the power cord. (See Fig. 36)
7. Re-install the component by referring to the removal procedure, above.
(Use only one ground-marked hole \oplus for ground connection.)
8. If the supply cord of this appliance is damaged, it must be replaced by the special cord.
(The special cord means the cord which has the same specification marked on the supply cord fitted to the unit.)

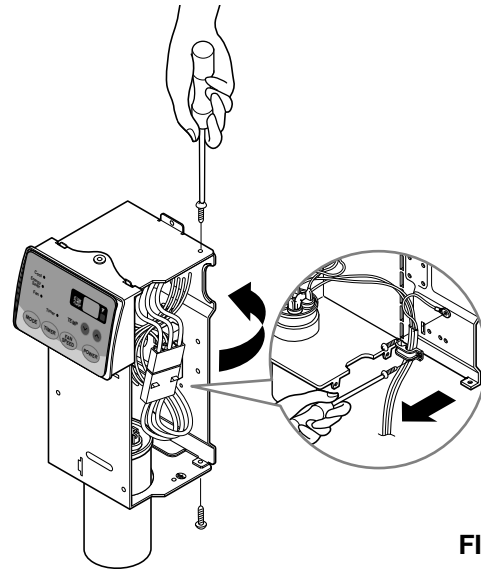

FIG. 36

11. THERMOSTAT

1. Remove the control box. (Refer to section 3)
2. Unfold the control box. (Refer to section 9)
3. Disconnect the thermostat terminals from main P.W.B assembly.
4. Remove the thermostat. (See Fig. 37)
5. Re-install the components by referring to the removal procedure, above.

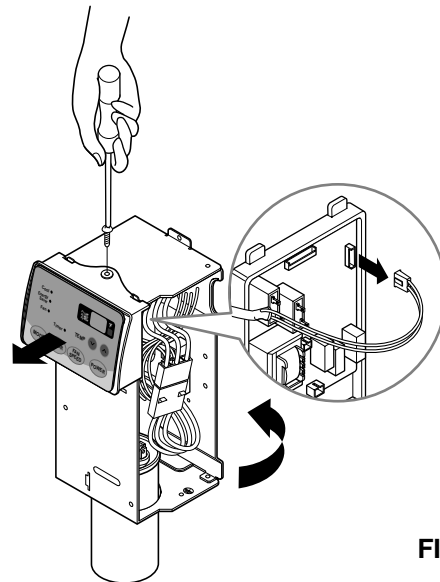

FIG. 37

Refrigerating Cycle

CAUTION

Discharge the refrigerant system using Freon™ Recovery System. If there is no valve to attach the recovery system, install one (such as a WATCO A-1) before venting the Freon™. Leave the valve in place after servicing the system.

12. CONDENSER

1. Remove the cabinet. (Refer to section 2)
2. Remove the brace and the shroud cover. (Refer to section 4)
3. Remove the 5 screws which fasten the condenser.
4. After discharging the refrigerant completely, unbraid the interconnecting tube at the condenser connections.
5. Remove the condenser.
6. Re-install the components by referring to notes. (See Fig. 38)

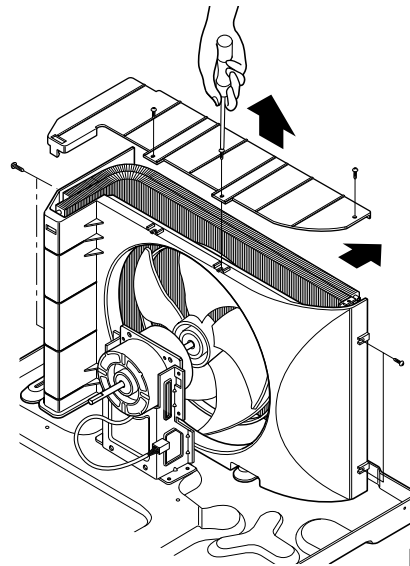

FIG. 38

13. EVAPORATOR

1. Remove the cabinet. (Refer to section 2)
2. Discharge the refrigerant completely.
3. Remove the 2 screws which fasten the evaporator at the left side and the right side.
4. Move the evaporator sideward carefully and then unbraid the interconnecting tube at the evaporator connectors.
5. Remove the evaporator.
6. Re-install the components by referring to notes. (See Fig. 39)

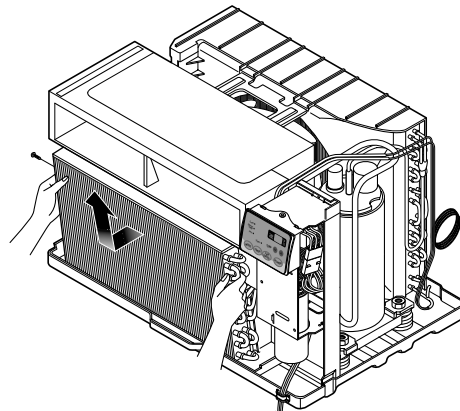

FIG. 39

14. CAPILLARY TUBE

1. Remove the cabinet. (Refer to section 2)
2. After discharging the refrigerant completely, unbraid the interconnecting tube at the capillary tube.
3. Remove the capillary tube.
4. Re-install the components by referring to notes.

NOTICE

— Replacement of the refrigeration cycle.

1. When replacing the refrigeration cycle, be sure to discharge the refrigerant system using a Freon™ recovery System.
If there is no valve to attach the recovery system, install one (such as a WATCO A-1) before venting the Freon™. Leave the valve in place after servicing the system.
2. After discharging the unit completely, remove the desired component, and unbrace the pinch-off tubes.
3. Solder service valves into the pinch-off tube ports, leaving the valves open.
4. Solder the pinch-off tubes with Service valves.
5. Evacuate as follows.
 - 1) Connect the vacuum pump, as illustrated Fig. 40A.
 - 2) Start the vacuum pump, slowly open manifold valves A and B with two full turns counterclockwise and leave the valves closed.
The vacuum pump is now pulling through valves A and B up to valve C by means of the manifold and entire system.

CAUTION

If high vacuum equipment is used, just crack valves A and B for a few minutes, then open slowly with the two full turns counterclockwise. This will keep oil from foaming and being drawn into the vacuum pump.

- 3) Operate the vacuum pump for 20 to 30 minutes, until 600 microns of vacuum is obtained. Close valves A and B, and observe vacuum gauge for a few minutes. A rise in pressure would indicate a possible leak or moisture remaining in the system. With valves A and B closed, stop the vacuum pump.
- 4) Remove the hose from the vacuum pump and place it on the charging cylinder. See Fig. 40B. Open valve C.
Discharge the line at the manifold connection.
- 5) The system is now ready for final charging.

6. Recharge as follows :

- 1) Refrigeration cycle systems are charged from the High-side. If the total charge cannot be put in the High-side, the balance will be put in the suction line through the access valve which you installed as the system was opened.
- 2) Connect the charging cylinder as shown in Fig. 40B. With valve C open, discharge the hose at the manifold connection.
- 3) Open valve A and allow the proper charge to enter the system. Valve B is still closed.
- 4) If more charge is required, the high-side will not take it. Close valve A.
- 5) With the unit running, open valve B and add the balance of the charge.
 - a. Do not add the liquid refrigerant to the Low-side.
 - b. Watch the Low-side gauge; allow pressure to rise to 30 lbs.
 - c. Turn off valve B and allow pressure to drop.
 - d. Repeat steps B and C until the balance of the charge is in the system.
- 6) When satisfied the unit is operating correctly, use the pinch-off tool with the unit still running and clamp on to the pinch-off tube. Using a tube cutter, cut the pinch-off tube about 2 inches from the pinch-off tool. Use sil-fos solder and solder pinch-off tube closed. Turn off the unit, allow it to set for a while, and then test the leakage of the pinch-off connection.

Equipment needed: Vacuum pump, Charging cylinder, Manifold gauge, Brazing equipment. Pinch-off tool capable of making a vapor-proof seal, Leak detector, Tubing cutter, Hand Tools to remove components, Service valve.

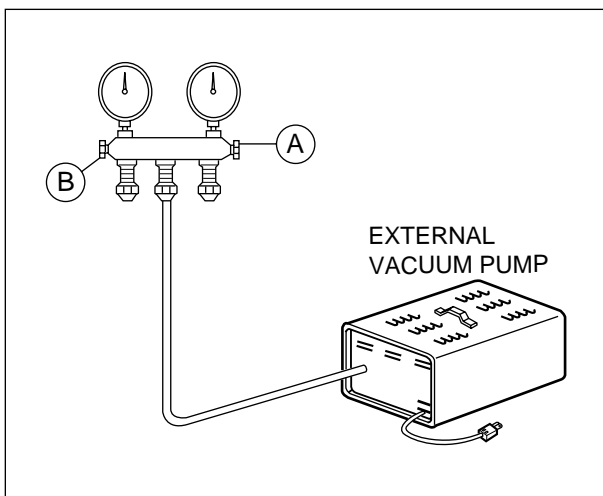
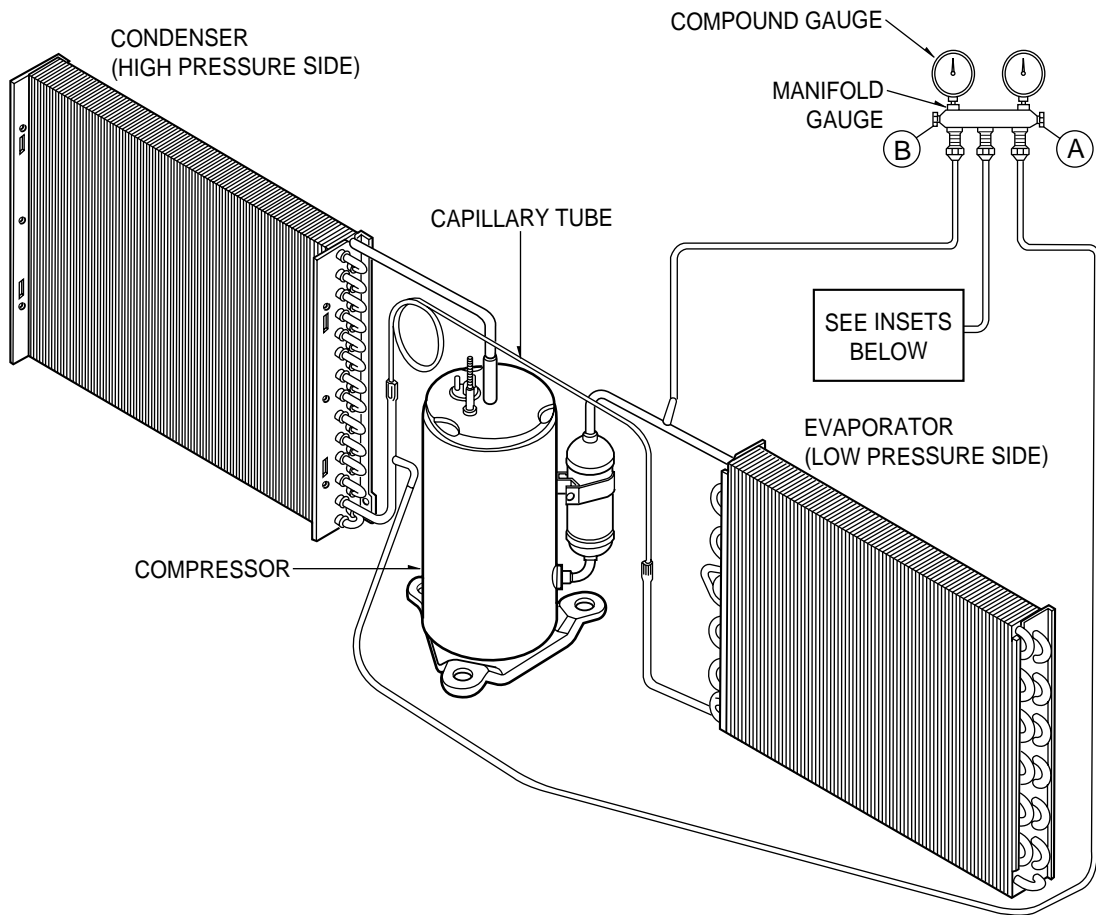

FIG. 40A-Pulling Vacuum

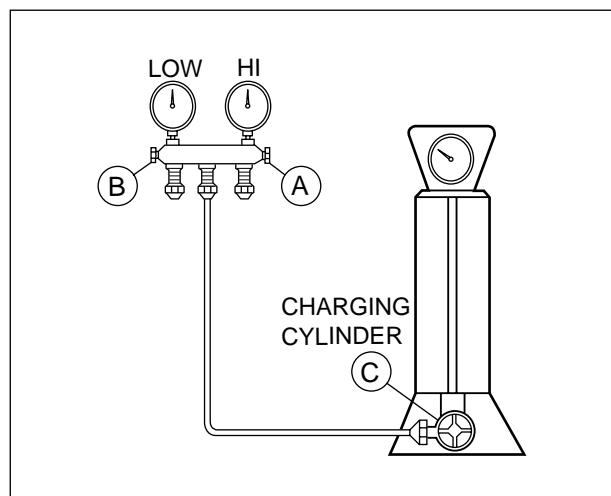
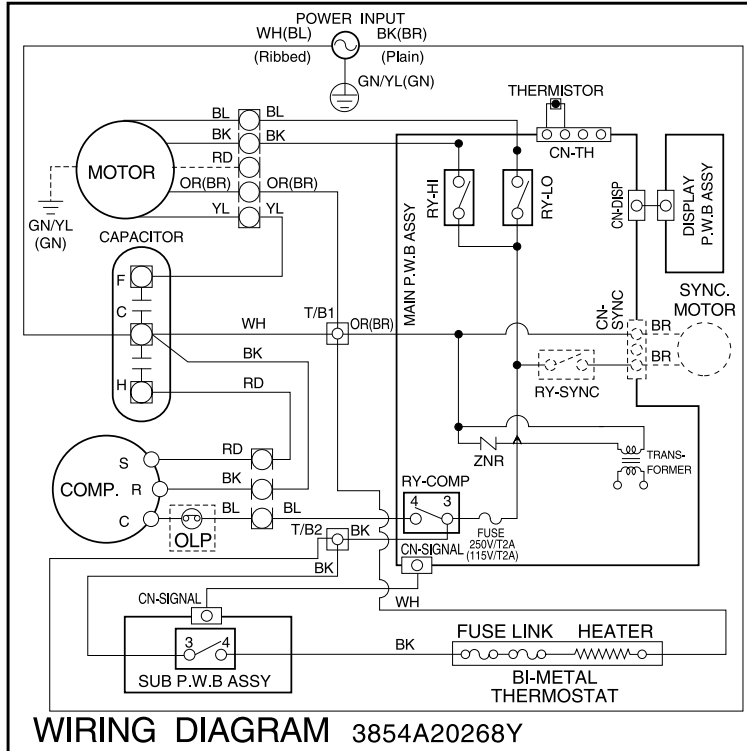

FIG 40B-Charging

Schematic Diagram

Wiring Diagram

■ ELECTRIC HEATING MODEL



Troubleshooting Guide

Piping System

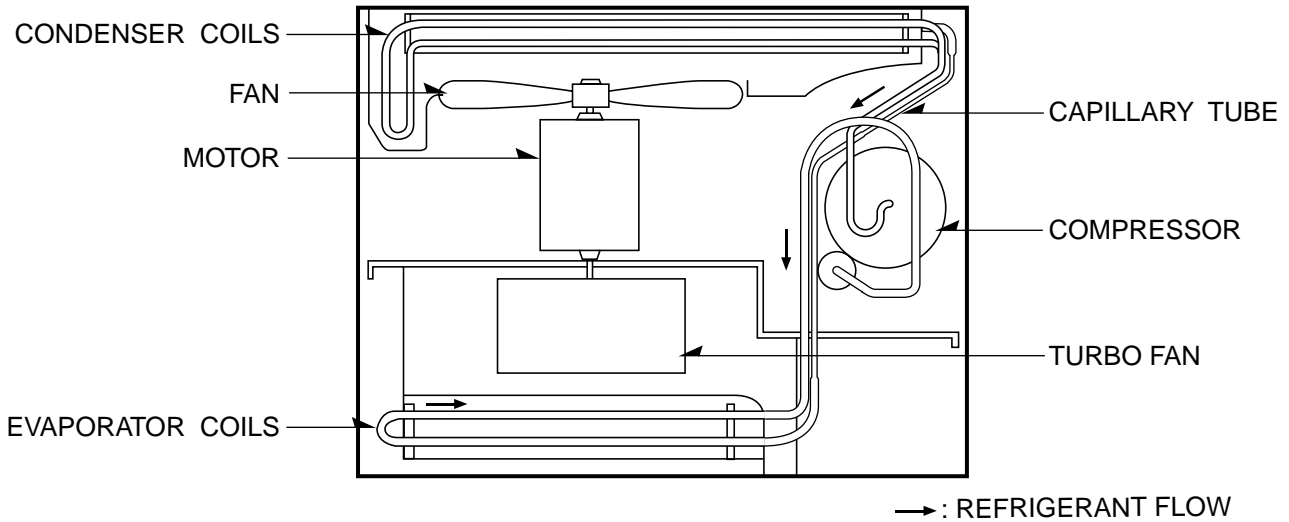

Following is a brief description of the important components and their functions in the refrigeration system. Refer to Fig. 41 to follow the refrigeration cycle and the flow of the refrigerant in the cooling cycle.

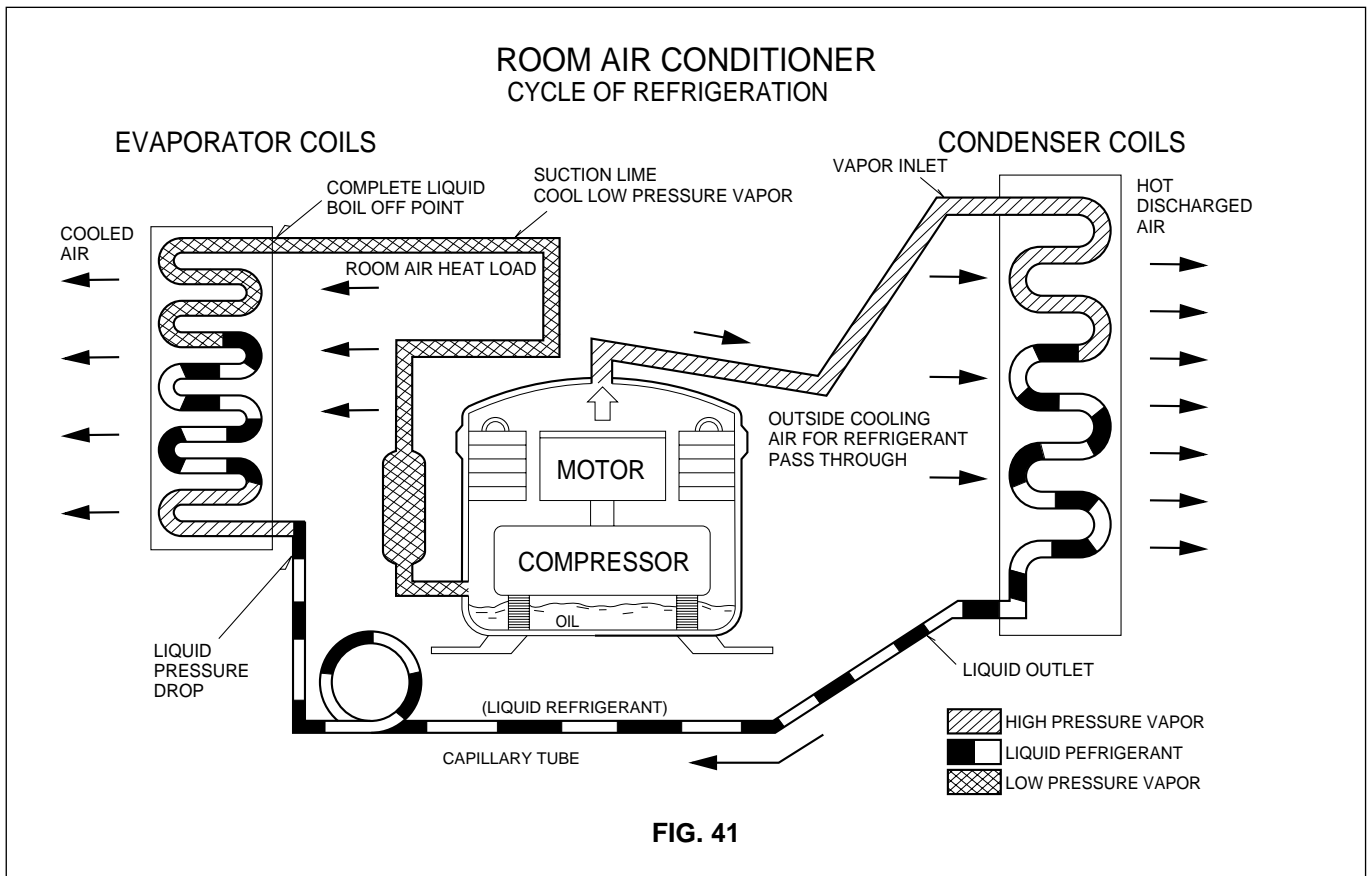

Troubleshooting Guide

In general, possible trouble is classified in two causes.

The one is called Starting Failure which is caused from an electrical defect, and the other is Ineffective Air Conditioning caused by a defect in the refrigeration circuit and improper application.

Unit is running but cooling is ineffective

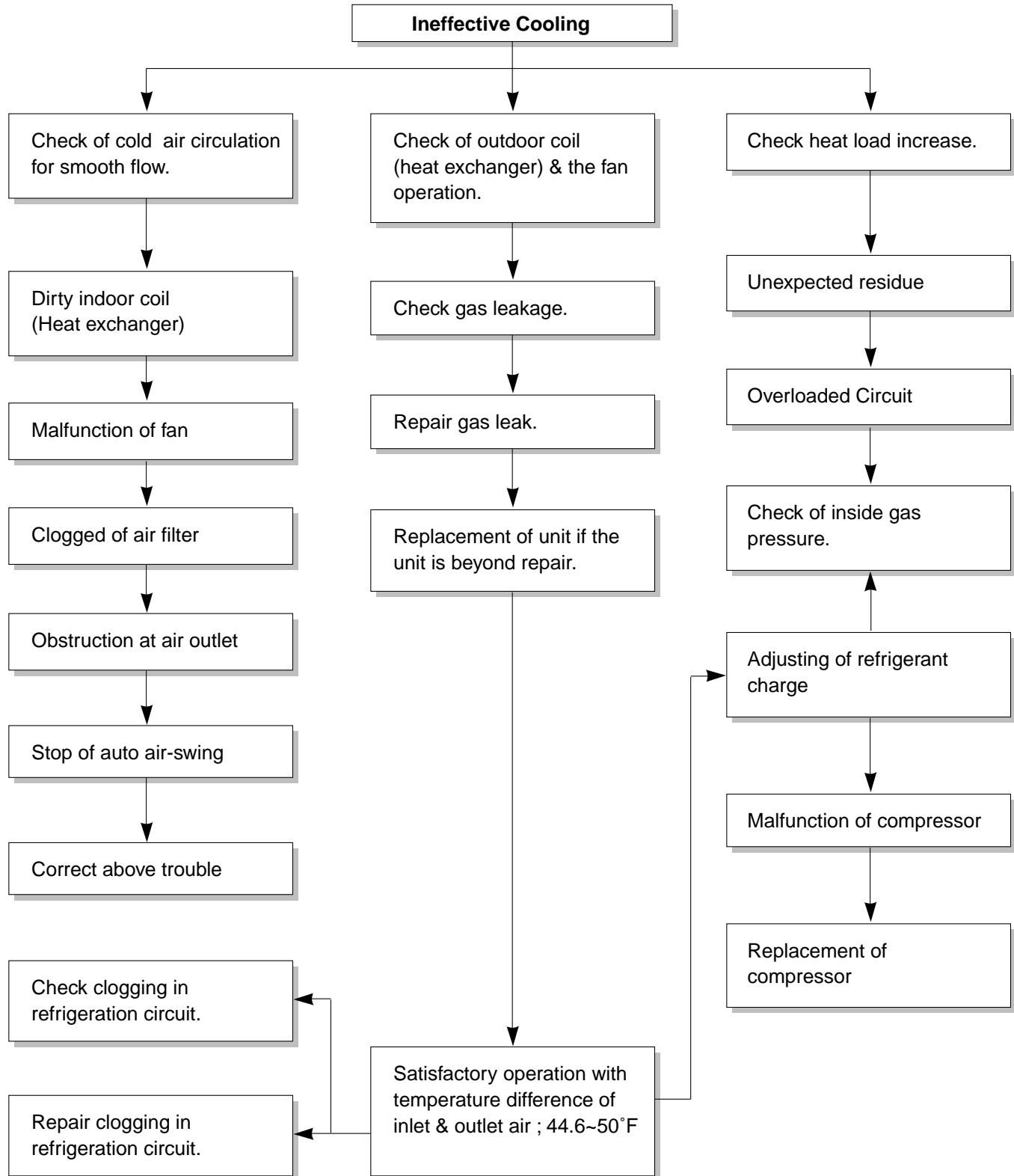

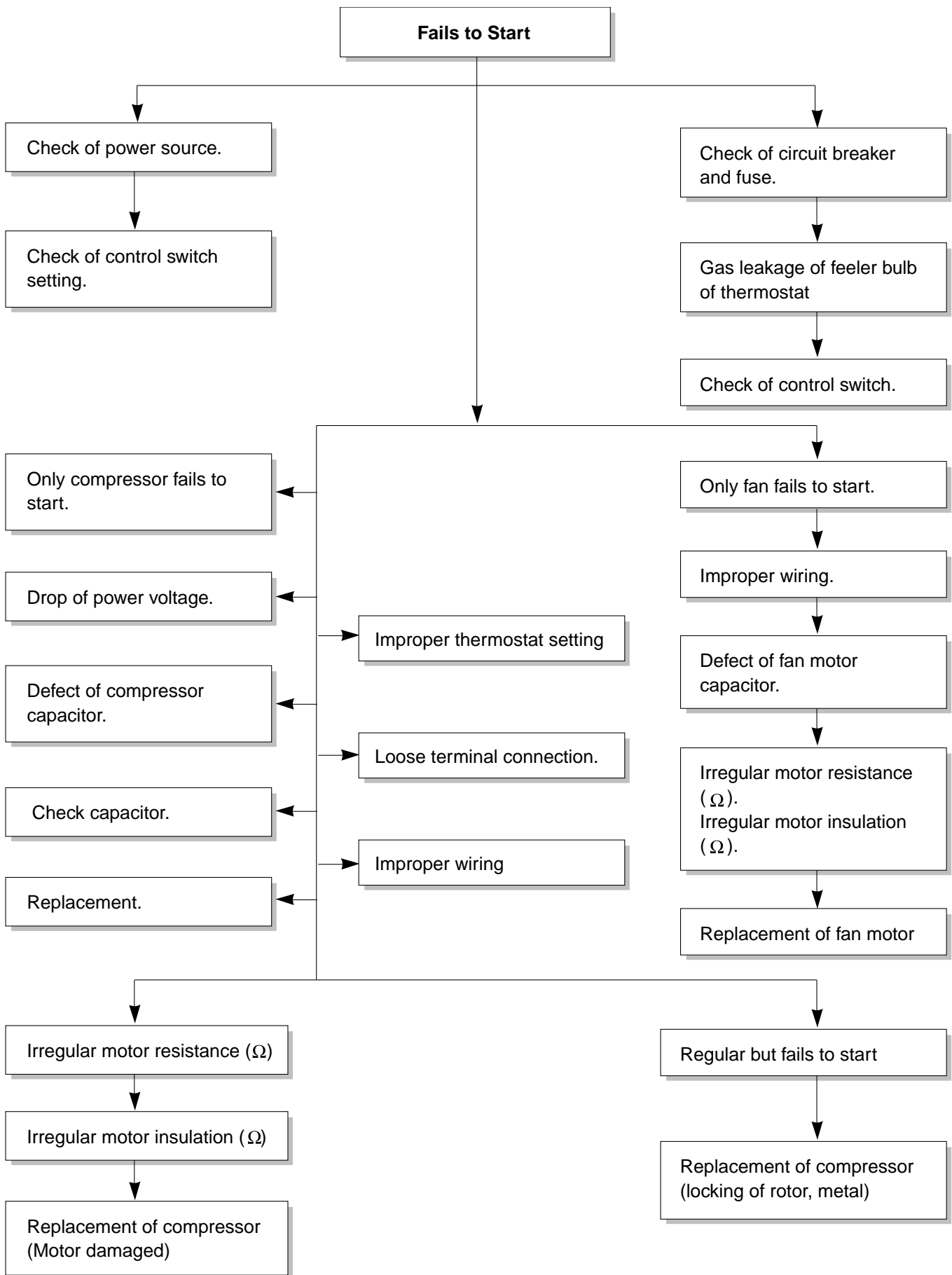

COMPLAINT	CAUSE	REMEDY
Fan motor will not run.	No power	Check voltage at outlet. Correct if none.
	Power supply cord	Check voltage to rotary switch. If none, check power supply cord. Replace cord if circuit is open.
	Rotary switch	Check switch continuity. Refer to wiring diagram for terminal identification. Replace switch if defective.
	Wire disconnected or connection loose	Connect wire. Refer to wiring diagram for terminal identification. Repair or replace loose terminal.
	Capacitor (Discharge capacitor before testing.)	Test capacitor. Replace if not within $\pm 10\%$ of manufacturer's rating. Replace if shorted, open, or damaged.
	Will not rotate	Fan blade hitting shroud or blower wheel hitting scroll. Realign assembly. Units using slinger ring condenser fans must have $\frac{1}{4}$ to $\frac{5}{16}$ inch clearance to the base. If it is hitting the base, shim up the bottom of the fan motor with mounting screw(s). Check fan motor bearings; if motor shaft will not rotate, replace the motor.
Fan motor runs intermittently	Revolves on overload.	Check voltage. See limits on this page. If not within limits, call an electrician. Test capacitor. Check bearings. Does the fan blade rotate freely? If not, replace fan motor. Pay attention to any change from high speed to low speed. If the speed does not change, replace the motor.
Fan motor noise.	Grommets	Check grommets; if worn or missing, replace them.
	Fan	If cracked, out of balance, or partially missing, replace it.
	Turbo fan	If cracked, out of balance, or partially missing, replace it.
	Loose set screw	Tighten it.
	Worn bearings	If knocking sounds continue when running or loose, replace the motor. If the motor hums or noise appears to be internal while running, replace motor.

COMPLAINT	CAUSE	REMEDY
Compressor will not run, but fan motor runs.	Voltage	Check voltage. See the limits on the preceding page. If not within limits, call an electrician.
	Wiring	Check the wire connections, if loose, repair or replace the terminal. If wires are off, refer to wiring diagram for identification, and replace. Check wire locations. If not per wiring diagram, correct.
	Rotary	Check for continuity, refer to the wiring diagram for terminal identification. Replace the switch if circuit is open.
	Thermostat	Check the position of knob. If not at the coldest setting, advance the knob to this setting and restart unit. Check continuity of the thermostat. Replace thermostat if circuit is open.
	Capacitor (Discharge capacitor before servicing.)	Check the capacitor. Replace if not within $\pm 10\%$ of manufacturer's rating. Replace if shorted, open, or damaged.
	Compressor	Check the compressor for open circuit or ground. If open or grounded, replace the compressor.
	Overload	Check the compressor overload, if externally mounted. Replace if open. (If the compressor temperature is high, remove the overload, cool it, and retest.)

ROOM AIR CONDITIONER VOLTAGE LIMITS

NAME PLATE RATING	MINIMUM	MAXIMUM
115V	103.5V	126.5V
208/230V	187V	253V

COMPLAINT	CAUSE	REMEDY
Compressor cycles on overload.	Voltage	Check the voltage. See the limits on the preceding page. If not within limits, call an electrician.
	Overload	Check overload, if externally mounted. Replace if open. (If the compressor temperature is high, remove the overload, cool, and retest.)
	Fan motor	If not running, determine the cause. Replace if required.
	Condenser air flow restriction	Remove the cabinet. inspect the interior surface of the condenser; if restricted, clean carefully with a vacuum cleaner (do not damage fins) or brush. Clean the interior base before reassembling.
	Condenser fins (damaged)	If condenser fins are closed over a large area on the coil surface, head pressures will increase, causing the compressor to cycle. Straighten the fins or replace the coil.
	Capacitor	Test capacitor.
	Wiring	Check the terminals. If loose, repair or replace.
	Refrigerating system	Check the system for a restriction.
Insufficient cooling or heating	Air filter	If restricted, clean or replace.
	Exhaust damper door	Close if open.
	Unit undersized	Determine if the unit is properly sized for the area to be cooled.
Excessive noise.	Blower or fan	Check the set screw or clamp. If loose or missing, correct. If the blower or fan is hitting air guide, rearrange the air handling parts.
	Copper tubing	Remove the cabinet and carefully rearrange tubing not to contact cabinet, compressor, shroud, and barrier.

Product Specifications

ITEMS \ MODELS		REMARK	BGE-103A	BGE-123A	REMARK
COOLING	POWER SUPPLY		1Ø, 208/ 230V, 60Hz		
	CAPACITY (Btu/h)		9,800/10,000	11,200/11,500	
	INPUT (W)		1,040/1,060	1,270/1,310	
	RUNNING CURRENT (A)		5.2/4.7	6.4/6.0	
	E. E. R. (Btu/W. h)		9.4	8.8	
HEATING	CAPACITY (Btu/h)		9,200/11,200		
	INPUT (W)		2,900/3,500		
	RUNNING CURRENT (A)		14.0/15.3		
OPERATING TEMPERATURE	COOLING	INDOOR (° C)	26.7 (DB)	19.4 (WB)	
		OUTDOOR (° C)	35 (DB)	23.9 (WB)	
	HEATING	INDOOR (° C)	21.1 (DB)	15.6 (WB)	
		OUTDOOR (° C)	8.3 (DB)	6.1 (WB)	
REFRIGERANT (R-22) CHARGE(g)		465(16.40 OZ)	500(17.6 OZ)		
EVAPORATOR		3 ROW 12 STACKS			LOUVERED-FIN TYPE
CONDENSER		2 ROW 17 STACKS, L-BENDED TYPE			
FAN, INDOOR		TURBO FAN			
FAN, OUTDOOR		PROPELLER TYPE FAN WITH SLINGER-RING			
FAN SPEEDS (FAN/COOLING/HEATING)		2 / 2 / 2			
FAN MOTOR		6 POLES	4 POLES		
OPERATION CONTROL		TOUCH PANEL			
ROOM TEMP. CONTROL		THERMISTOR			
AIR DIRECTION CONTROL		VERTICAL LOUVER (RIGHT & LEFT)			
		HORIZONTAL LOUVER (UP & DOWN)			
CONSTRUCTION		TOP-DOWN			
ELECTRIC HEATER		3.5KW, 230V			
PROTECTOR	COMPRESSOR		EXTERNAL OVERLOAD PROTECTOR		
	FAN MOTOR		INTERANL THERMAL PROTECTOR		
	ELECTRIC HEATER		FUSE LINK, BIMETAL THERMOSTAT		
POWER CORD		1.92m (3 WIRE WITH GROUDING)			
		ATTACHMENT PLUG (CORD-CONNECTED TYPE)			
DRAIN SYSTEM		SPLASHED BY FAN SLINGER			
NET WEIGHT (lbs/kg)		80/36	81/37		
DIMENSION (W x H x D)	(inch)	24 ^{21/32} x 14 ^{13/32} x 19 ^{21/32}			
	(mm)	626 x 366 x 499			
SLEEVE DIMESION (W x H x D)	(inch)	257/8 x 1517/32 x 1623/32			OPTIONA PART
	(mm)	656 x 394 x 425			
SLEEVE DEPTH	(inch)	20			
WITH FRONT GRILLE	(mm)	510			

Exploded View

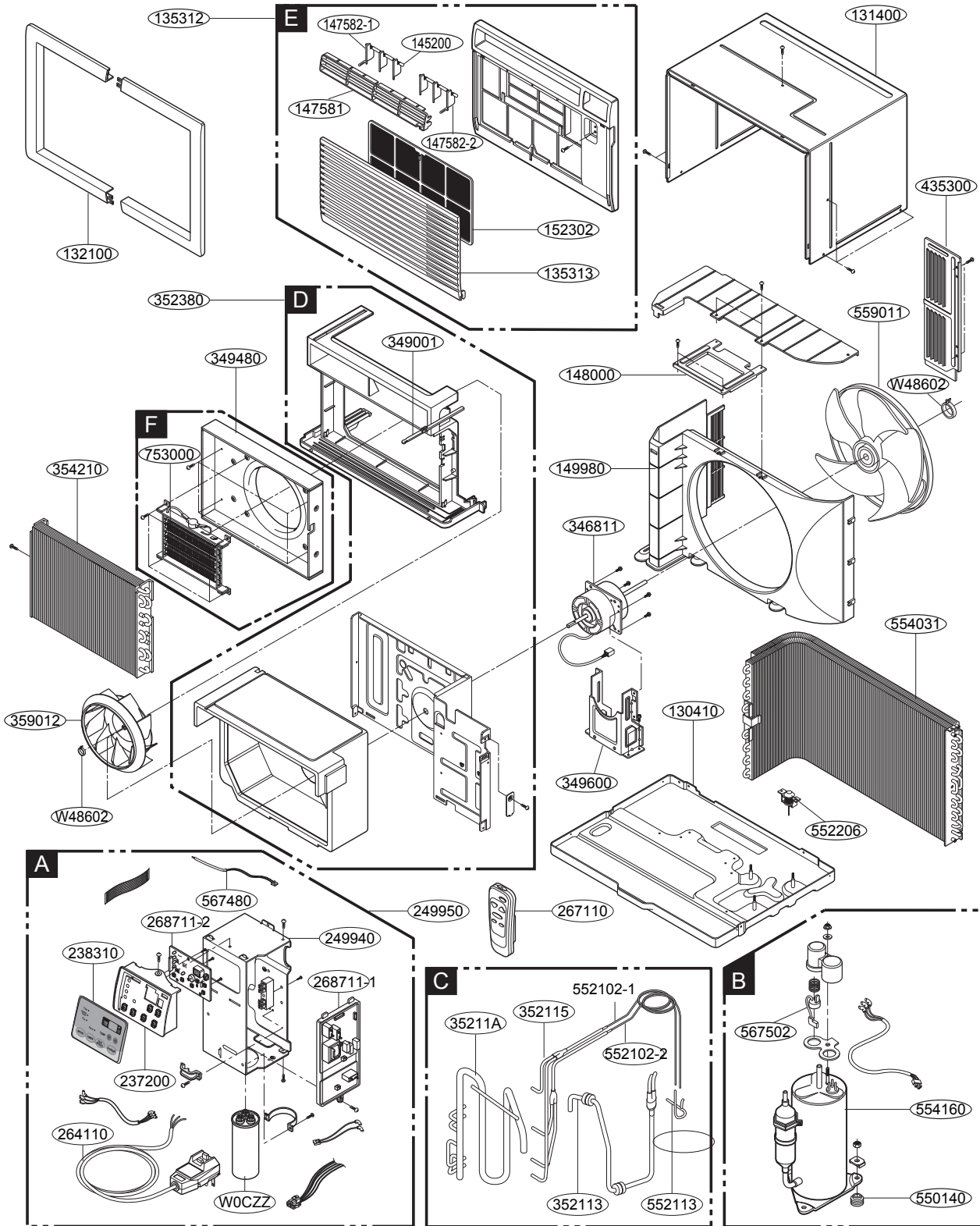

Replacement Parts List

R: Service Parts

N: Non Service parts

	LOCATION NO.	DESCRIPTION	PART NO.		REMARK
			BGE-103A	BGE-123A	
A	249950	Case Assembly,Control	ABQ32921702		R
	249940	Case,Control	4994A10096A		R
	237200	Panel,Control	3720A10305A		R
	268711-1	PCB Assembly,Main	EBR30851604		R
	268711-2	PCB Assembly,Display	EBR30852201		R
	W0CZZ	Capacitor,Film,Box	0CZZA10002C		R
	238310	Escutcheon	MDD37791801		R
	264110	Power Cord Assembly	6411A20056Q		R
	567480	Thermistor,NTC	6323A20003F		R
B	567502	Overload Protect	6750UL028A	6750UL058A	R
	554160	Compressor Set,China	TBZ31004601	TBZ31097401	R
	550140	Damper,Compressor	4H00982C		R
C	35211A	Tube Assembly,Suction	5211A25028A	5211A25028B	R
	352115	Tube Assembly,Evaporator(In)	5211A29024G		R
	352113	Tube Assembly,Discharge	5211A21421C	5211A21421G	R
	552113	Tube Assembly,Condenser(Out)	5211A21809B		R
	552102-1	Tube,Capillary Bending	5210A22592M		R
	552102-2	Tube,Capillary Bending	5210A22592L		R
D	352380	Guide Assembly,Air	5239A10002G		R
	349001	Damper,Vent	4900A20001A		R
E	135312	Grille Assembly,Front	3531A20055G	3531A20055H	R
	135303	Grille,Inlet	3530A20020A		R
	152302	Filter,Air	5230A20007A		R
	147581	Louver,Horizontal	4758A20008B		R
	147582-1	Louver,Vertical	4758A20009A		R
	147582-2	Louver,Vertical	4758A20009B		R
F	130410	Base Assembly,Single	3041A10038D	3041A10038F	R
	349600	Bracket,Motor	4960A20005A	4960A20008A	R
	346811	Motor,AC	4681A20041C	4681A20041M	R
	552206	Valve,Drain	5220A30006A		R
	559011	Fan Assembly,Axial	5900AR1173A		R
	349480	Orifice	4948A10006A		R
	753000	Heater,Electric	5300A20003A		R
	W48602	Clamp,Spring	3H02932B		R
	149980	Shroud	4998A10007B		R
	435300	Grille,Rear	MDX33964101		R
	359012	Fan,Turbo	5900A20009B		R
	148000	Supporter	4800A30002A		R
	354210	Evaporator Assembly,First	5421A20071J		R
	554031	Condenser Assembly,Bending	5403A20040T		R
	131400	Cabinet	3090A20003C		R
	132100	Frame	4918A20001A		R
	267110	Remote Controller Assembly	6711A20093A		R

Specifications and performance data subject to change without notice.

HEAT CONTROLLER, INC.

1900 WELLWORTH AVENUE • JACKSON, MICHIGAN 49203

THE QUALITY LEADER IN CONDITIONING AIR

P/No.: 3828A20040M