

This Owner's Manual is provided and hosted by [Appliance Factory Parts](#).

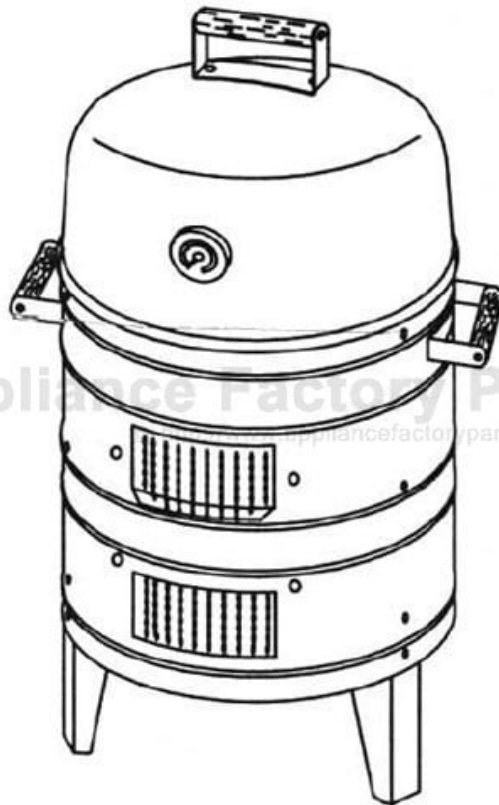

Meco 5024 Owner's Manual

[Shop genuine replacement parts for Meco 5024](#)



[Find Your Meco Grill Parts - Select From 46 Models](#)

----- Manual continues below -----

MECO[®]

CORPORATION



STAINLESS WATER SMOKERS

*For the Ultimate
Flavor Experience*

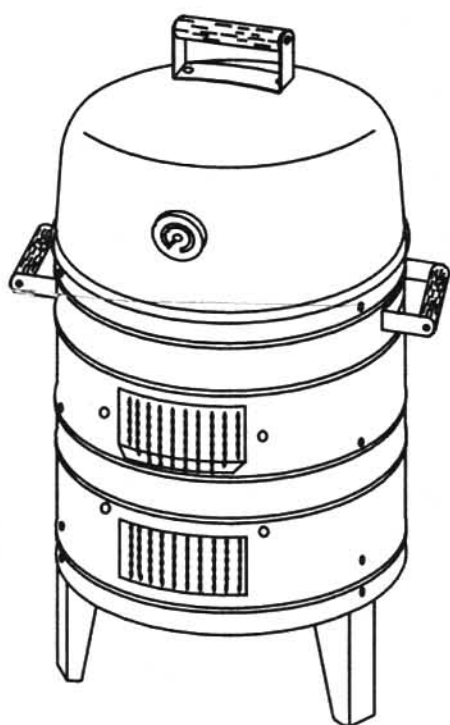

MODEL 5024/5025
CHARCOAL

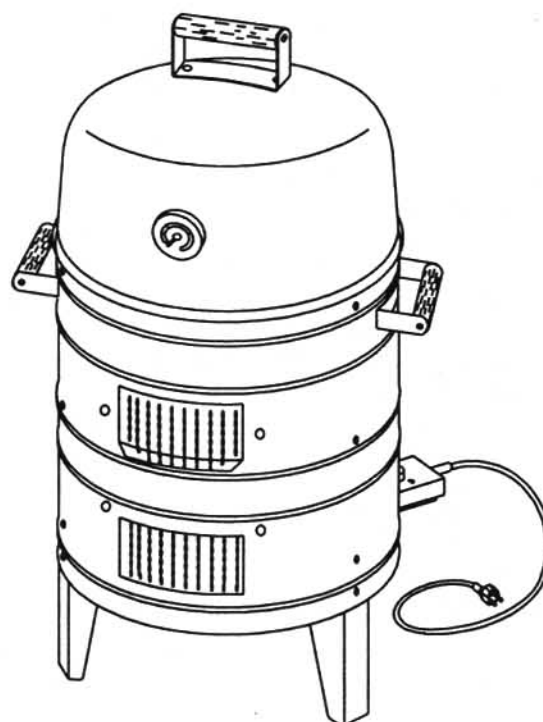

MODEL 5028/5029P
ELECTRIC

ASSEMBLY AND USE MANUAL

P/N 03.5774.02
REV. 11/98

IMPORTANT SAFEGUARDS

WARNING: FAILURE TO FOLLOW THESE SAFETY RULES MAY RESULT IN SERIOUS INJURY OR PROPERTY LOSS. READ AND FOLLOW INSTRUCTIONS CAREFULLY BEFORE USING GRILL.

CHARCOAL SAFEGUARDS

- ▲ **WARNING:** Do not use charcoal for indoor cooking or heating. Toxic carbon monoxide fumes may accumulate and cause death.
- ▲ **WARNING:** Do not use gasoline, kerosene, or alcohol for igniting charcoal.
- ▲ **CAUTION:** Do not use "instant lighting" charcoal.
- ▲ **WARNING:** Keep small children away from your Grill to avoid burns.
- ▲ **CAUTION:** Open the Hood carefully when cooking. The hot air and steam trapped inside can burn.
- ▲ **CAUTION:** Use a drip pan under the Charcoal Smoker when using on a wood deck.

ELECTRIC SAFEGUARDS

1. Read all instructions.
2. **WARNING: DO NOT USE CHARCOAL IN AN ELECTRIC GRILL.**
3. Always use your grill in a well ventilated area. **Never** touch hot surfaces. Use cooking tongs, gloves, or cooking mitts at all times since the grill will become very hot. Open Hood carefully when cooking to avoid burns from the hot air and steam trapped inside.
4. Wear clothing that does not have hanging shirt tails, frills, or apron strings.
5. Use baking soda to control a grease fire and have a fire extinguisher available.
6. Close supervision is necessary when any appliance is used by or near children. **Never** allow other persons near the grilling area while grill is in use. Keep bystanders out of the grilling area.
7. **Never** use an electric grill in the rain, sleet or snow.
8. **Never** use an electric grill near combustible or flammable materials.
9. Electrical supply cords should always be secured during appliance operation to protect against product damage or personal injury. Do not let cords hang over the edge of table or counter, or touch hot surfaces.
10. To protect against electric shock, **never** immerse cord, plug, or Electric Element in water or any other liquid.
11. **Never** leave element on when you are not cooking. Do not leave grill unattended. Unplug Grill from outlet when not in use, before moving or cleaning. Allow grill to cool before cleaning, adding or removing parts. Do not clean grill with water spray or the like.
12. Inspect regularly supply cord and connections. **Never** operate any appliance with damaged electrical parts or after the appliance has malfunctioned or has been damaged in any manner. Return to the nearest authorized service facility for examinations, repairs or adjustment.
13. Do not use appliance for other than intended use or alter product any way. The use of accessory attachments not recommended by the manufacturer may cause injuries.
14. Use only properly grounded 110-120 Volt outlet. Always attach plug to appliance first, then plug cord into the wall outlet. Turn Control knobs to OFF POSITION before unplugging electric grill.
15. The use of longer detachable power supply cords or extension cords is ~~not recommended~~. However, if such cords are used, they should be equal to or greater than the same grounding type 3-wire 14 Ga. cord of the appliance supply cord. The cord should be surface marked with the suffix letters "W-A" and bear a tag stating "Suitable For Use with Outdoor Appliances". When using extension cords, connections should be kept dry and off the ground. The length of the cord should be kept as short as possible and arranged so that it cannot be tripped over accidentally.
16. Use a protective, weatherproof cover for outdoor storage or store indoors out of the reach of children.
17. **NOTE:** MECO Model 1516 Control and Model 1517 Electric Element is for use **ONLY** with MECO Models 5028/5029 Water Smokers. Complete replacement kit is Model 1521.

• Contact MECO if you do not understand any of the instructions in this manual.

• Do not lend your grill without the Owners Manual. Be sure that anyone using your grill reads and understands the information contained in this manual.

SAVE THESE INSTRUCTIONS

— NOTICE —

MECO STRIVES TO BE A QUALITY SUPPLIER OF CONSUMER PRODUCTS. IF WE INADVERTENTLY OMITTED ANY PARTS NEEDED FOR ASSEMBLY, OR YOU NEED TROUBLESHOOTING INFORMATION, PLEASE CONTACT US USING OUR TOLL FREE NUMBER. MECO WILL SHIP REPLACEMENT PARTS MONDAY THRU FRIDAY WITHIN 24 HOURS. SATURDAY & SUNDAY ORDERS WILL SHIP THE NEXT WORK DAY. THANK YOU FOR PURCHASING A MECO PRODUCT.

**1-(800)-346-3256
[24 HOURS/7 DAYS A WEEK]
1-(423)-639-1171 (TELEPHONE)
1-(423)-639-2570 (FAX)**

or write:

**CONSUMER SERVICE DEPARTMENT
MECO CORPORATION
1500 INDUSTRIAL ROAD
GREENEVILLE, TN. 37745 USA**

MODEL 5024/5025 ASSEMBLY INSTRUCTIONS

TOOLS NEEDED: Phillips screwdriver, 3/8" open-end wrench or pliers.

ITEM	PARTS LIST DESCRIPTION	PART #	QTY. PER MODEL			
			5024	5025	5028	5029P
1	Body Assy, Charcoal	—	1	1	—	—
2	Body Assy, Electric	—	—	—	1	1
3	Bolt, 10-24 x 1/2"	03020102	18	—	19	—
4	Bolt, 10-24 x 1/2" Stainless	03020105	—	18	—	19
5	Leg, Aluminized	17168600	3	—	3	—
6	Leg, Stainless	17169000	—	3	—	3
7	Lock Nut 10-24	03039000	18	—	18	—
8	Lock Nut 10-24 Stainless	03039001	—	18	—	18
9	Pan Bracket	17167700	3	—	3	—
10	Pan Bracket Stainless	17547000	—	3	—	3
11	Grid Bracket	17546900	3	—	3	—
12	Grid Bracket Stainless	17548900	—	3	—	3
13	Handle Bracket Aluminized	17165300	3	—	3	—
14	Handle Bracket Stainless	17548000	—	3	—	3
15	Wood Handle	03090000	3	3	3	3
16	Wood Screw, 5/8"	03042400	6	—	6	—
17	Wood Screw, 5/8" Stainless	03042401	—	6	—	6
18	Hood, Painted	17165018	1	—	1	—
19	Hood, Stainless	03532900	—	1	—	1
20	Heat Indicator	03160202	1	1	1	1
21	Water Pan/Charcoal Pan	03070100	2	2	1	2
22	Cooking Grid	03522300	2	2	2	2
23	Reflector Pan	17541300	—	—	1	1
24	Electric Element	03072701	—	—	1	1
25	Wing Nut 10-24	03575000	—	—	1	—
26	Wing Nut 10-24 Stainless	03575001	—	—	—	1
27	Element Control	03072300	—	—	1	1
28	Hickory Chunk	03500505	2	2	2	2
29	Owners Manual	03577402	1	1	1	1
Note: Specify color on Part # with(—) at end.						

Step 1. Take all parts out of the box and lay them on a smooth, clean surface. For helpful hints on how to assemble your smoker, read the next few pages before you start.

NOTE: The parts you need depend upon which model smoker you have. Look on the carton UPC LABEL and match the model number to the one shown on the Parts List. The parts under your model are the ones you need. Do not throw away packaging until you have finished assembly.

Step 2. Turn Charcoal Body Assembly (1) upside down. Put Bolt (3-4) through lower hole of Body, through bottom hole of Leg (5-6). Attach Lock Nut (7-8). Put Bolt (3-4) through hole in Body through top hole in Leg. Attach Lock Nut (7-8), tighten Bolts and Nuts. Repeat for other Bolts, Lock Nuts and Legs to the Body. Stand Body Assembly on the Legs.

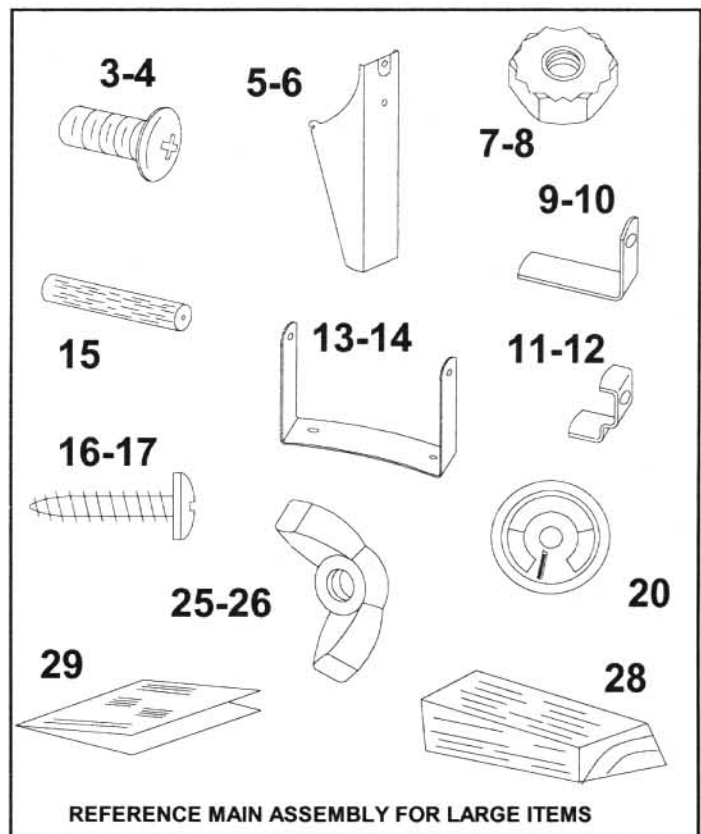

Step 3. Attach Pan Bracket (9-10) with Bolt (3-4) through center hole in Body. Attach Lock Nut (7-8) and tighten. Make sure long side of Bracket is down. Repeat for other Pan Brackets around the Body.

Step 4. Put Bolt (3-4) through top hole in Body Assembly (1) and through Grid Bracket (11-12). Make sure long side of Grid Bracket is toward the bottom. Attach Lock Nut (7-8) and tighten. Repeat for other Bolts, Grid Brackets and Lock Nuts around top of Body.

Step 5. Place Handle Bracket (13-14) over one pair of holes on the side and at top of Body Ass'y. (Arrange so the word 'MECO' is right-side up.) Attach with Bolts (3-4) and Lock Nuts (7-8) and tighten. Repeat for Handle Bracket on opposite side of Body Assembly.

Step 6. Place Wood Handle (15) inside of Handle Bracket (13-14). Put Wood Screw (16-17) through Handle Bracket into Hole in Wood Handle and tighten. Repeat for the other end of Handle. Attach other Wood Handle on opposite side of Body.

Step 7. Place Handle Bracket (13-14) over the pair of holes in the top of the Hood (18-19). Attach with Bolt (3-4) and Lock Nut (7-8) and tighten. Attach Wood Handle (15) to Handle Bracket with Wood Screws (16-17).

Step 8. Align bumps on Heat Indicator (20) with notches in large hole in Hood (18-19). Insert Heat Indicator into hole and rotate it 1/4 turn till dial face is straight up. Assist the turning with your other hand inside the Hood.

Step 9. Place a Water/Charcoal Pan (21) inside Smoker so round edge rests on Leg (5-6) at bottom of Body.

Step 10. Place a Water/Charcoal Pan (21) inside Smoker so round edge rests on Pan Brackets (9-10) at center of Body. Place a Cooking Grid (22) over Water Pan. Place other Cooking Grid within Grid Brackets (11-12) at top of Body. Cooking Grid should rest on long side of Grid Brackets.

Step 11. Place Hood Assembly on top of Grid Brackets (11-12). Hood should rest on upper short side of Grid Brackets. Water Smoker is now ready for use but **FIRST READ CHARCOAL SAFEGUARDS ON PAGE 2.**

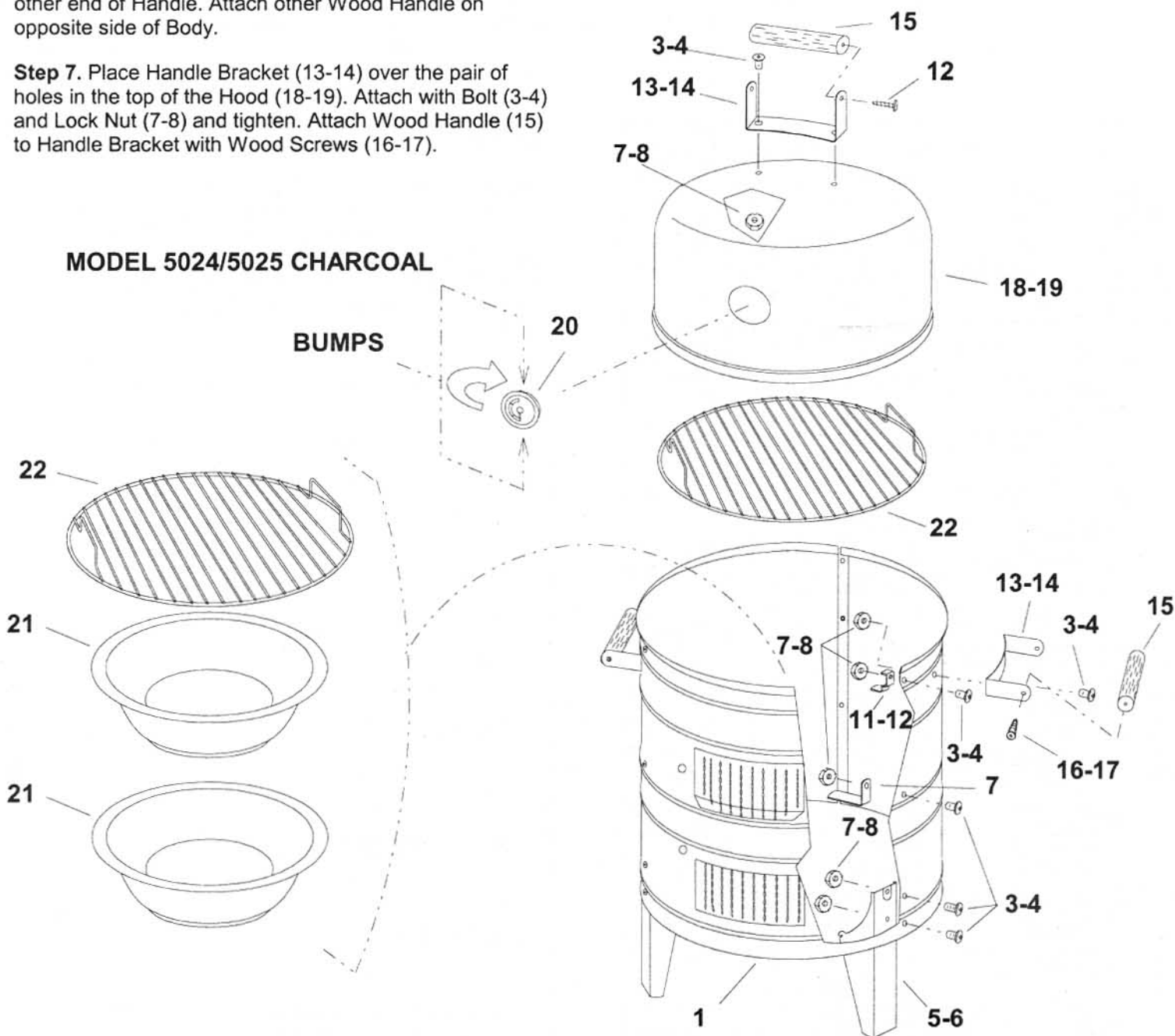

MODEL 5028/5029P ASSEMBLY INSTRUCTIONS

TOOLS NEEDED: Phillips screwdriver, 3/8" open-end wrench or pliers.

Step 1. Take all parts out of the box and lay them on a smooth, clean surface. For helpful hints on how to assemble your smoker, read the next few pages before you start.

NOTE: The parts you need depend upon which model smoker you have. Look on the carton and match the model number to the one shown on the Parts List. The parts under your model are the ones you need. Do not throw away packaging until you have finished assembly.

Step 2. Turn Electric Body Assembly (2) upside down. Put Bolt (3-4) through lower hole of Body, through bottom hole of Leg (5-6). Attach Lock Nut (7-8). Put Bolt (3-4) through hole in Body through top hole in Leg.

NOTE: If you are starting out using your 5029P unit as charcoal, follow the assembly for 5024/5025 page 3 & 4.

Attach Lock Nut (7-8), tighten Bolts and Nuts. Repeat for other Bolts, Lock Nuts and Legs to the Body. Stand Body Assembly on the Legs.

Step 3. Align notches of Reflector Pan (23) with top of Legs. Push the Reflector Pan down over the Legs.

Step 4. Attach Pan Bracket (9-10) with Bolt (3-4) through center hole in Body. Attach Lock Nut (7-8) and tighten. Make sure long side of Bracket is down. Repeat for other Pan Brackets around the Body.

MODEL 5028/5029P ELECTRIC

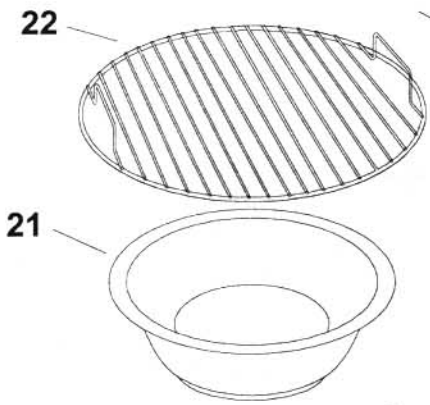

BUMPS

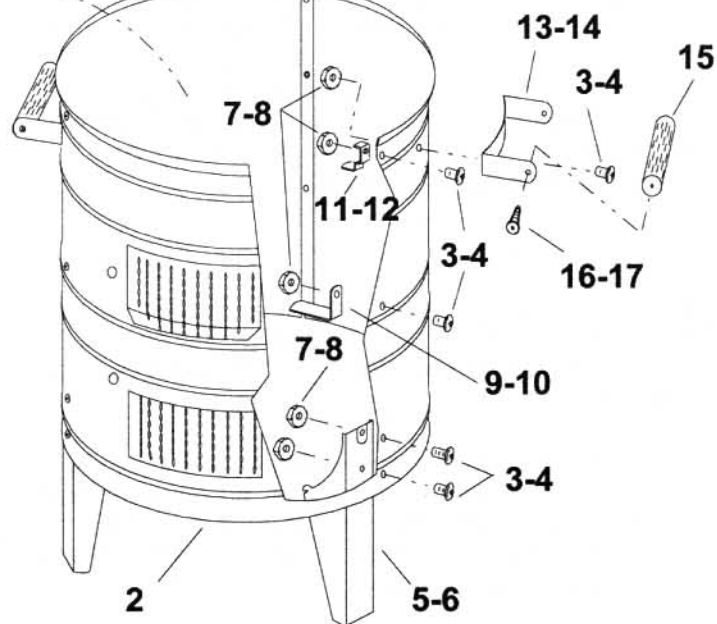
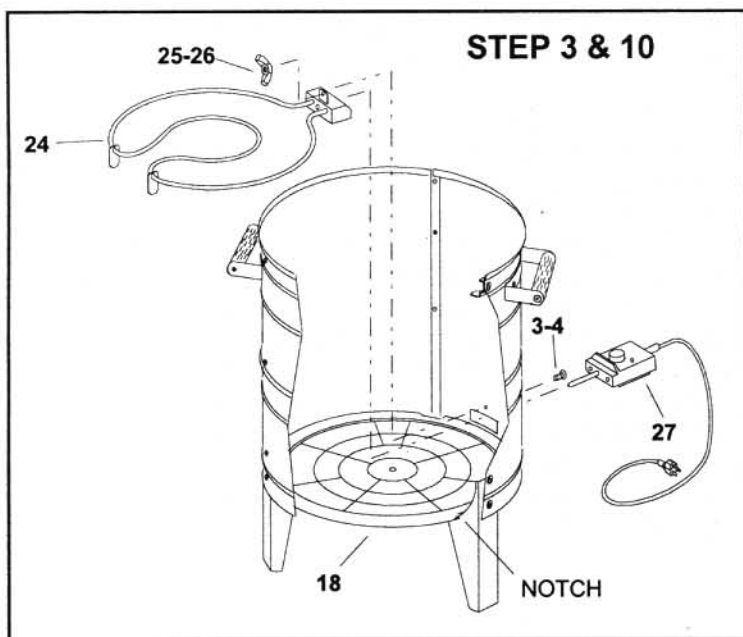
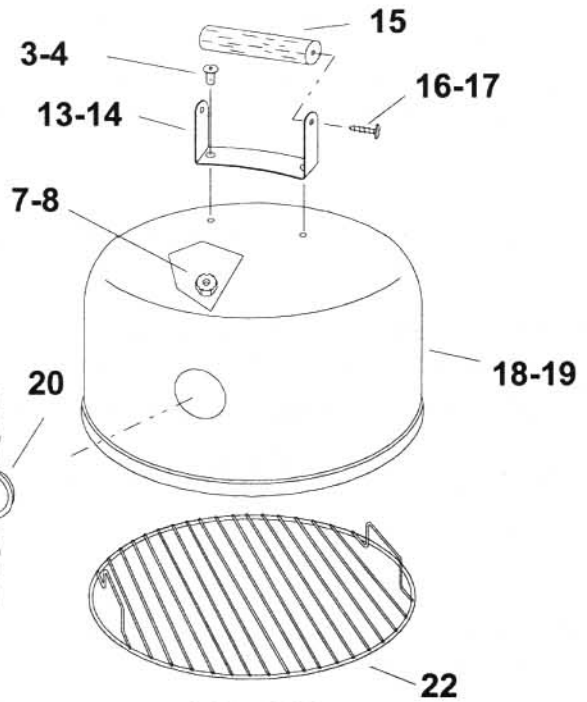

Step 5. Put Bolt (3-4) through top hole in Body Assembly and through Grid Bracket (11-12). Make sure long side of Grid Bracket is toward the bottom. Attach Lock Nut (7-8) and tighten. Repeat for other Bolts, Grid Brackets and Lock Nuts around top of Body.

Step 6. Place Handle Bracket (13-14) over one pair of holes on the side at top of Body Assembly. (Arrange so the word 'MECO' is right-side up.) Attach with Bolts (3-4) and Lock Nuts (7-8) and tighten. Repeat for Handle Bracket on opposite side of Body Assembly.

Step 7. Place Wood Handle (15) inside of Handle Bracket (13-14). Put Wood Screw (16-17) through Handle Bracket into Hole in Wood Handle and tighten. Repeat for the other end of Handle. Attach other Wood Handle on opposite side of Body.

Step 8. Place Handle Bracket (13-14) over the pair of holes in the top of the Hood (18-19). Attach with Bolt (3-4) and Lock Nut (7-8) and tighten. Attach Wood Handle (15) to Handle Bracket (13-14) with Wood Screws (16-17).

Step 9. Align bumps on Heat Indicator (20) with notches in large hole in Hood (18-19). Assist the turning with your other hand inside the Hood.

Step 10. Install Electric Element (24) into smoker with the shield bracket through rectangular opening in the Body.

Put a Bolt (3-4) from the outside through the round hole above the rectangular opening. Attach a Wing Nut (25-26) and tighten. (SEE INSET FIG. PAGE 5)

Step 11. Place Water/Charcoal Pan (21) inside Smoker so round edge rests on Pan Brackets (9-10) at center of Body. Place a Cooking Grid (22) over Water Pan. Place other Cooking Grid within Grid Brackets (11-12) at top of Body. Cooking Grid should rest on long side of Grid Brackets.

Step 12. Plug Element Control (27) into Electric Element (24). Make sure it is all the way in and you have a good connection.

Step 13. Place Hood Assembly on top of Grid Brackets (11-12). Hood should rest on upper short side of Grid Brackets. Water Smoker is now ready for use but **FIRST READ ELECTRIC SAFEGUARDS ON PAGE 2.**

GETTING AQUAINTED WITH YOUR SMOKER

LOOK AT WHAT YOU HAVE:

You now own a Water Smoker which can slow cook all your large meats such as turkeys, ham or game...

Charcoal Models can be converted to Electric with the purchase of Model 1512 Electric Element Kit..

No matter which method you cook, you will enjoy your Smoker for a long time, and within a short while you will be impressing your dinner company. (See Smoke Cooking Section Page 7 for details.)

USE AND CARE:

Break-in the Element to remove the new appliance smell before cooking the first time. Plug in the Element, set the control on High and burn it for about 10 minutes with the Hood off.

Electric Cooking is simple and similar to cooking with charcoal. Cooking time varies slightly, but no lighter fluid or charcoal is needed. You will need to cook on High unless you are only warming. Use a meat thermometer on whole meats when you can.

For extra smoke flavor, use hickory or mesquite chips sprinkled around Element coils. Small wood chunks can be placed on or touching the Element coils. Soak wood chips or chunks in water at least 30-60 minutes before cooking. Amount of chips or chunks vary to degree of smoke flavor you want and amount of food. (See Smoke Cooking Section Page 7.)

Clean-up is made easy by spraying Grid and Reflector Pan with cooking spray before cooking. For added protection, line Water Pan and Charcoal Pan with aluminum foil. Make sure you do not cover any holes for venting. When Smoker has cooled down, wash Grid, Water Pan and outside of Smoker with warm soapy water. Wipe excess grease from inside the Smoker. The rest will be dark and smoky—just let it stay that way. **NEVER USE OVEN CLEANER ON PAINTED SURFACES.** For the Electric unit, just wipe off the Reflector Pan, the Element and Control. **DO NOT IMMERSE IN WATER.** Replace all the clean parts. Store the Smoker in an out-of-the-way spot. Cover with a Smoker Cover or a plastic garbage bag if you wish.

SMOKE COOKING

CHARCOAL MODELS:

NOTE: BEFORE USING THESE CHARCOAL APPLIANCES, READ SAFETY RULES ON PAGE 2.

Put your Meco Water Smoker outside on a level surface out of traffic and away from trees or buildings. There won't be very much smoke but you may want to put the smoke away from open windows.

CAUTION: Use a drip pan under your smoker if you are using the Smoker on a wood deck. Use aluminum foil or any other material that will not burn if you don't have a drip pan.

STEP 1. For easy clean up later, line the inside of the Charcoal Pan and Water Pan with aluminum foil. Leave the Charcoal Pan hole open so the charcoal will get air.

CAUTION: Do not use "instant lighting" charcoal.

STEP 2. Put the Charcoal Pan in the bottom of the Smoker. Fill the Pan with good quality charcoal briquettes. (Approximately 10 pounds) Check the Quick Glance Cooking Chart on the back page for the right amount.

STEP 3. Sprinkle one 8 ounce cup of charcoal lighter fluid over the briquettes. Let the fluid soak into the briquettes for about one minute.

STEP 4. Light the charcoal with a match and let it burn for about 30 minutes or until the briquettes are covered with a grey ash. If you use an electric charcoal starter, omit the lighter fluid and follow electric starter instructions.

WARNING: Do not use charcoal for indoor cooking or heating. Toxic carbon monoxide fumes may accumulate and cause death.

STEP 5. When ready to cook, add wood chunks (if you wish) on top of the charcoal . . . use long handled tongs. (See WOOD page 8.)

STEP 6. Put the Water Pan in place and fill with water. Use hot tap water if the temperature is 50 degrees or less. (Warm water otherwise.) Some recipes may use less water with other liquids such as soda, beer or wine.

STEP 7. Put the top Cooking Grid in place. Arrange food in a single layer with space between each piece so heat and smoke can penetrate. If double cooking, always put the smaller meat on the bottom grid.

STEP 8. Put Hood on Body. Smoke for time given in the Quick Glance Cooking Chart (back page) or recipe. **DO NOT** lift the Hood except to check for doneness because it will slow down the cooking. Add at least 15 minutes to cooking time for each time you lift the Hood.. **DO NOT STIR CHARCOAL AFTER YOU START COOKING!**

STEP 9. If cooking more than **six hours**, you may need to add water or charcoal. Check both water level and charcoal through the access door. Wear an insulated mitt, or use a barbecue tool, to slide the door up to its open position. If water is needed, use a watering can with a long spout. A plastic milk jug will work if you don't have one.

Add hot charcoal, or wood chunks, by placing them on the burning charcoal. Don't toss them in. That will just stir up ashes that will get onto your food. If you need to cook for a long time, start the additional charcoal in a separate container and add it after about twenty to thirty minutes.

STEP 10. If you wish, use the juices in the water pan to make Gravy: Skim off the fat and measure the juices. Use 1 tablespoon fat, 1 tablespoon flour and one cup juices for each cup of gravy.

STEP 11. Use coals that remain for Smoke Flavored Foods (page 10) or cover and let them burn out. When coals are cold, you can lift out any remaining briquettes to use another time.

STEP 12. Always dump the ashes after each use. Wash water pan and grid with hot suds or in dishwasher.

WARNING: Make sure none of the coals are still burning before you dump them.

ELECTRIC MODELS:

NOTE: BEFORE USING THESE ELECTRICAL APPLIANCES, READ IMPORTANT SAFEGUARDS ON PAGE 2.

STEP 1. Before you cook the first time, make sure you "break-in" the Electric Element to remove the new appliance smell. (Page 6) Make sure the Element is installed properly, then plug the cord into a grounded 110-120 Volt 15 Amp outlet. Turn the Control on High and warm up the Smoker while you finish your preparations. Leave the Hood off.

STEP 2. When you are ready to cook, add wood chips or chunks (if you wish) around the Electric coils. (See WOOD Page 8.) When Smoke Cooking, cook with Control on High unless recipe calls for other temperature.

STEP 3. Put the Water Pan in place and fill with water. Use hot tap water if the temperature is 50 degrees or less. (Warm water otherwise.) Some recipes may use less water with other liquids such as soda, beer or wine.

STEP 4. Put the top Cooking Grid in place. Arrange food in a single layer with space between each piece so heat and smoke can penetrate. If double cooking, always put the smaller meat on the bottom grid.

STEP 5. Put Hood on Body and smoke for time given in the Quick Glance Cooking Chart (back page) or recipe.

Note: Cooking times could be shorter than shown on chart. Get acquainted with cooking operation of your unit with various food.

STEP 6. If cooking more than **six hours**, you may need to add water to the water pan. Check the water level through the access door. Wear an insulated mitt, or use a barbecue tool, to slide the door up to its open position. If water is needed, use a watering can with a long spout. A plastic milk jug will work if you don't have one.

CHARCOAL:

Hardwood charcoal briquettes make the hottest, longest lasting fire. Look for quality. The cheapest charcoal is not a good buy if it does not burn well. Always close unused bags of charcoal by rolling the tops down tightly. Store charcoal in a dry place. Charcoal that's left out in the rain or dew will not burn well.

Most charcoal briquettes average about 14 briquettes per pound. Always use a least five pounds of charcoal. Bigger cooking jobs need more charcoal, so follow the recipes or the Quick Glance Cooking Chart on back page that tells how much charcoal to use.

WOOD:

The smokehouse flavor comes from the green or wet wood that you put on the glowing coals. If the wood isn't green or wet, it will burn instead of smoking. Use wood from deciduous trees (they shed their leaves in the winter) only, NOT from evergreen trees. Evergreens, such as pine, are resinous and will ruin the flavor and appearance of food. DO use hickory, apple, peach, pecan or other fruit or nut tree woods. Mesquite is a popular smoking wood in the Southwest, palmetto is used in the South and some Midwesterners use dried corncobs. Experiment with all of them.

You can buy or cut wood for smoking from several forms. Chips are often available in 1-1/2 or 2 pound bags. You'll usually find them right next to charcoal in the supermarket. Chunks of cross cut trees should be about 3-4 inches long and 1/2 inch diameter. The cooking chart and recipes call for one stick, chunk, or handful of chips but you can use whatever form you prefer. Chunks give the longest lasting smoke. Your own experimentation will help you determine how much to use to get the amount of smoke flavor that you want.

To assure proper Electric Smoking performance, use HICKORY CHUNKS instead of chips. Place the chunks between the element sections so the chunks actually touch the element. If using wood chips, sprinkle them under and near the element coils.

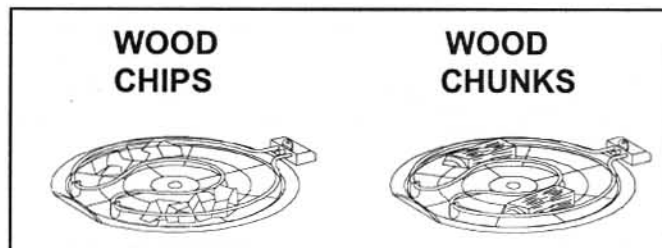

BARBECUING:

You can change your Charcoal Water Smoker into a barbecue grill in less than a minute. Set the Charcoal Pan on top of the lower Cooking Grid. Light the charcoal as you normally would for smoke cooking. When ready to cook, put the other cooking Grid on the upper Grid Brackets. Now you are ready to cook steaks, burgers or other food which require high, fast heat. Add wood chips or chunks if you want smoke flavor. Cover with the Hood to hold in the heat and moisture.

ROASTING/BAKING:

You can cover cook foods at temperatures similar to a medium hot oven by cooking without water. Set up the grill (charcoal or electric) the same as you would for water smoking but omit the Water Pan, and don't add wood chips. Roasting is good for very thick steaks, chickens and small tender roasts such as tenderloins. Remember that roasting times are much shorter than water smoking times.

STEAMING:

You can cook foods with low, moist heat in your water smoker. Just don't add wood chips or chunks. You'll get great cooking in the same times as shown in the Cooking Chart but there won't be any smoke flavor.

TESTS FOR DONENESS:

Some of the recipes that follow and the Quick Glance Cooking Chart, give meat thermometer readings as test for doneness. Lift the hood to check the meat thermometer only at the end of the minimum cooking time given in the chart.

Smoked foods do look a little different from oven or grill cooked foods, so your eye cannot always judge doneness. A meat thermometer is the only sure way to tell if a piece of meat is cooked the way you want it.

Smoked poultry, for instance, usually will look slightly pink, especially around the joints and just under the skin even though it is done. Pork, also will show pink color, even though it's well done.

Always be sure to insert the meat thermometer into the meat so the tip is in the center of the largest muscle, away from bone or fat. The Quick Glance Cook Guide gives you standard doneness temperatures for most meats. The chart also gives descriptions of doneness for foods that are too small for a thermometer such as chicken pieces, fish, etc.

USE A MEAT THERMOMETER

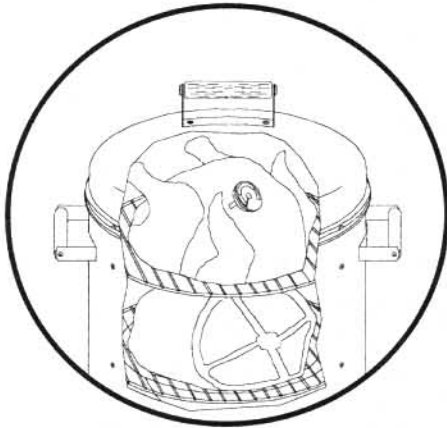

Use a MEAT THERMOMETER for judging the doneness of the meat. Whenever the outside air temperature is 70 degrees Fahrenheit or below, allow the meat to cook for at least the minimum time shown on Quick Glance Cooking Chart before opening the hood. The purpose of the heat indicator on the hood is to give only a relative indication of how the smoker is performing. The actual cooking temperature is influenced by many variables. You will have the most success in cooking by checking the actual temperature of the meat being cooked.

TIMING:

You'll notice that there are ranges of one to two hours in cooking times in the Chart and in the recipes. This is because there are so many factors that can speed up or, more often, slow down the rate of smoke cooking. Wind, type of charcoal, temperature of the food, outside temperature, relative humidity, number of times you lift the hood, temperature of water in the water pan, thickness and weight of food can all have an effect, so cooking times have to be approximate. There's very little chance that you will overcook food in your water smoker, except when barbecuing or roasting without the water pan. When the water pan is in place and full of water, it keeps the heat so low and even that, especially at the end of long cooking periods, food will stay hot and moist for several hours.

If the outside temperature is below 55-60 degrees F, if you live above 4000 feet, or if it is very windy (move smoker out of direct wind), allow extra time for cooking.

If you forget to take the meat out of the refrigerator for half an hour or so before putting it on to cook, allow extra cooking time. Meat must be completely thawed before putting it on to cook. Don't forget to check the water pan after four-five hours of cooking time.

If your Charcoal Smoker is beginning to cool down or you need to cook for longer periods of time:

Start about 5-7 pounds additional charcoal in a separate container. When ready, slide the access door open using barbecue mitts or protective cloth. Add the charcoal briquettes with long handled tongs to the charcoal ring. Don't just throw them in . . . this will stir up ashes. Add hot water to the water pan if you need to.

SCHEDULING:

Long, slow smoke cooking is such a change from our usual hurry-up way of life that it takes some adjusting to. It's a good idea to set yourself a countdown so your food will be cooked before your scheduled meal time. Cooks that don't plan ahead may find themselves with a yard full of hungry and less than happy guests if the food comes out of the smoker two hours later than planned.

Base your countdown on the longest cooking time shown on the chart or recipe. Count backward from the time you want to eat, then add another hour to start your fire, take the meat out of the refrigerator to get the chill off, soak the wood chunks and generally get everything ready to cook. The first hour of preparation is the most work you'll have to do while smoke cooking.

WHAT IF..? Even the best planned schedule can go wrong, so here some tips for those rare occasions:

Try to always have some appetizers, or perhaps a salad to serve first to give you some flexibility on the serving time in case your food is not done on schedule.

If the food is cooking too slow and guests have consumed all your appetizers...try one of the following: Remove the water pan to allow all the heat from the charcoal to get to the meat. If you're waiting for a large piece of meat or a large turkey, cut it into smaller sections; it won't be as juicy as if cooked whole but it will finish faster. If you have run out of charcoal, move the meat inside to a 400 F oven.

If the food has cooked faster than planned and is beginning to dry out... Baste the meat with juices from the water pan and wrap it in foil. Leave it on the cooking grid to stay warm until serving time. If serving time is more than an hour or so, put some ice into the water pan and fill it with cold water.

What if roasts don't look like oven cooked meats? Remember that water smoking isn't the same as oven roasting. Beef may look less crusty than if oven-cooked and it may be paler. Just brush it with gravy coloring, barbecue sauce, soy sauce or teriyaki sauce, then dig in and enjoy.

FOOD SAFETY:

A lot of what's called the "24 hour virus" is really food borne illness. A word to the wise can prevent discomfort to family and friends. Cleanliness is indeed a virtue. All utensils, all work surfaces and the cook must be clean. If you have a cold or the flu, wait until another day to cook. Guests are less likely to share your malady and you're better off resting.

Do not let foods stand around at room or outside temperature. Other than the half hour period we recommend for meats to come out of the refrigerator to warm up before cooking, rush all food from refrigerator to table and back again. Keep meats hot in your water smoker for second helpings, then cover and refrigerate immediately . . . don't wait until after dessert! The rule is: keep hot foods hot and cold foods cold and get them to those temperatures as soon as possible.

We recommend you cook turkeys unstuffed. Prepare the stuffing and wrap it in foil to cook along side the bird, if you wish. It takes so long for stuffing in the center of a large

turkey to heat through that it's better to cook it separate.

TIPS FOR SUCCESS:

- Always thaw meat thoroughly.
- Let charcoal burn until it gets very hot . . . make sure the coals are glowing and covered with grey ash before cooking.
- Let meat stand at room temperature at least one half- hour before cooking.
- Do not lift hood to check for doneness until end of minimum cooking time given in charts.
- Add more cooking time if:
It's windy or colder than 50 degrees F.
You lift the hood often.
You cook at high altitude.
- Don't peek just to be sure the food is cooking. Look at the heat indicator, or feel the heat near the hood.

RECIPES FOR SMOKE COOKING

SMOKE FLAVORED FOODS

You can use the low, slow coals left at the end of cooking to flavor cheese, nuts, salt, seeds or other foods. After you've finished with the main cooking, remove the cooking grid and water pan. Add a few sticks, chunks or handfuls of soaked wood to the low coals. Put the water pan and cooking grid back in place. Put food on cooking grid, cover and let smoke flavor about 30-60 minutes for eggs and cheese or several hours for nuts, seeds and salt. Smoke flavor an 8-ounce piece of cream cheese or a same size piece of Cheddar, Monterey Jack or Colby Cheese. Put cheese on piece of foil. It will melt slightly around edges.

Or smoke flavor any whole nuts or seeds. Put nuts on piece of foil. Sprinkle with salt before smoking, if desired.

You can smoke-flavor hard-cooked eggs. Peel eggs and put on piece of foil. Smoke flavor 20 to 30 minutes, then chill. You can smoke-flavor salt, too. Use a shallow metal pan or tray made from foil. Sprinkle in a thin even layer of salt and smoke flavor several hours or until salt is amber colored.

SMOKED BEEF ROASTS

Serve with foil-cooked Italian green beans, water-pan-boiled new potatoes, a giant green salad and you've made a magnificent meal!

5-pound rolled and tied rib, rump, sirloin tip or round roast
Salt and Pepper
Magnificent Marinade or 1 package taco seasoning mix, spaghetti seasoning mix or beef stew seasoning mix or 3 cups red wine.
CHARCOAL: Level pan full
WOOD: 1 to 2 sticks, chunks or handfuls chips
Rub salt and pepper or any of the seasoning mixes into meat or marinate in Marinade or wine several hours at room temperature or overnight in refrigerator. Insert meat thermometer with tip in center of largest muscle. Let stand at room temperature while lighting fire. When coals are ready, add wood. Put water pan in place and fill with 5-1/2 quarts hot

water or 4-1/2 quarts hot water plus marinade or wine. Put meat on cooking grid over water pan, fat-side up. Cover and smoke-cook to desired doneness about 4 hours for medium (160F). Reserve juices in water pan, skim off fat and serve juices with meat or thicken with gravy.

SUMPTUOUS SMOKED TURKEY

Experts agree smoked turkeys are more beautiful and flavorful than those cooked by any other method.

10-pound fresh or thawed frozen unstuffed turkey
Salt and Pepper
1 cup white wine, apple juice/cider or pineapple juice
1 tablespoon rosemary leaves
CHARCOAL: Level pan full
WOOD: 2 to 3 sticks, chunks or handfuls chips

Remove giblets and reserve for other use. Rinse turkey with cold water and sprinkle inside and out with salt and pepper. Insert meat thermometer in center of thickest part of thigh with tip away from bone. Let stand at room temperature while lighting fire. When coals are ready, add wood. Put water pan in place and fill with 5 quarts hot water. Add wine and rosemary leaves to water.
Put turkey on cooking grid over water pan. Cover and smoke-cook about 6 hours or until leg moves easily in socket. check water pan after 3 to 4 hours cooking and add more hot water as needed. Reserve and strain juices from water pan to thicken for gravy, if you wish.

SMOKED APPLE FLAVOR PORK CHOPS

6-1" thick pork chops
2 quarts apple juice and 1 quart water in water pan
Applewood chunks or trimmings directly on element.
Smoke for 2 to 3 hours or until meat reaches 170F.
(Check liquid in pan after approximately 2 hrs. and add if needed). Serve with applesauce and enjoy!

SMOKED GAME BIRDS

Pheasant, dove, quail, squab, Rock Cornish Hens are flavorful, rich and moist when smoke-cooked.
2 to 6 game birds (size will determine how many will fit on each level of grill)
Brine (1 gallon water and 1 cup salt)
Bacon slices
CHARCOAL: Rounded pan full
WOOD: 1 to 2 sticks, chunks or handfuls chips
Clean birds and pluck but do not skin. Soak in brine, if desired, refrigerate for several hours. Lift birds from brine, rinse with cold clear water and pat dry with paper towels. Brush with oil or, if birds are small, cover breasts with half-slice of bacon.
Arrange birds on cooking grid over water pan full of hot water.
Cover and Smoke-cook about 2 to 3 hours, depending on size of bird or until leg will move easily in socket.
MAKES: About 2 to 6 servings, depending on size of birds.

MAGNIFICENT MARINADE

For steaks, chops, chicken, ribs, almost any meat you like.
Pour over meat in plastic bag, pan or bowl and refrigerate several hours or overnight, turning occasionally. Cook meat in water smoker, adding marinade to water pan.
1-1/2 cups salad oil
3/4 cup soy sauce
1/2 cup win vinegar
1/3 cup lemon juice
1/4 cup Worcestershire sauce
2 tablespoons dry mustard
2-1/2 teaspoons salt
1 tablespoon coarsely ground pepper
2 teaspoons chopped parsley
2 cloves garlic, crushed
Combine all ingredients and mix well. Store in tightly covered jar in refrigerator or freezer if not used immediately.
MAKES: About 3-1/2 cups

WATER PAN POTATOES

Scrub but don't peel 1 pound medium-sized new potatoes, or quarter 4 to 6 large red or white potatoes. Slip potatoes into 4 quarts hot water in water pan, put in smoker over fire pan. Cover and cook about 1 hour or until done. You'll probably want to add potatoes to water pan for last hour of cooking time of meat, poultry or pork. Since liquid in water pan may have evaporated, be sure to add enough hot water to cover potatoes.
MAKES: About 6 servings.

QUICK GLANCE COOK GUIDE

ALWAYS FILL WATER PAN WITH APPROXIMATELY 5-1/2 QUARTS HOT WATER FROM TAP UNLESS RECIPE

INDICATES OTHER MEASUREMENT.

Food and Weight	Amount of Charcoal	Amount of Wood Chunks (See Page 9)	Temperature or Test for Doneness*	Smoke Cooking Time(Hours)	Number of Servings Per lb.
BEEF, Venison or Other Game Animal					
Boneless Roasts					
3-4 lbs.	level	1	140 degree F rare	3-4	3-4
5-7 lbs.	level full	1	160 degree F medium	5-6	
8-10 lbs.	heaping	2	170 degree F well	7-9**	
CHICKEN					
Fryers(2-2 1/2 lbs. ea.)					
1 to 3 whole, split or cut up	rounded	1	180 degree F or leg will move easily in socket	4-5	3-4
Roasters (5 lbs.) 1 or 2	rounded to heaping			6-8	3-4
FISH					
Filletts, full grill	level	1	flakes when forked	2-3	3-4
Steaks	level	1-2		2-3	
Whole Pan Fish	level	1-2		2-3	
Whole, large, 6 lb.	rounded	1-2		3-5	
GAME					
Small birds (dove, quail, squab, pheasant, duck)	rounded	2	leg will move easily in socket	3-5	1 to 3
HAM					
Cooked, all sizes	level	1-2	130 degree F	3-5	3-4
Fresh, 10 lb.	heaping	2-3	170 degree F	7-10**	
LAMB					
Leg or shoulder roasts 5-7 lb.	rounded	1-2	140 degree F rare 160 degree F rare 175 degree F done	5-7**	3-4
LOBSTER TAILS					
Full grill	level to rounded	1-2	flesh white and firm	1-2	2
PORK					
Chops, 6-8 lb. (1" thk)	rounded	1	170 degree F	3-4	3-4
Roasts, 3-5 lb.	rounded	1	170 degree F	5-7	
Roasts, 5-7 lb.	heaping	2	170 degree F	7-8**	2
Ribs, 5 lb.	rounded	1-2	well done, meat pulls away from bone	4-6	
SAUSAGE					
Links, full grill	level to rounded	1-2	well done, 170 degree F for cook before eating pork sausage	3-5 for cook before eating	3-4
SHRIMP					
	level	1	flesh white and firm	1-2	3
TURKEY (Unstuffed)					
8-12 lb.	level	2	180 degree F or leg will move easily in socket	7-9**	2-3
13-20 lb.	heaping	2-3		10-12**	

* Temperatures are those recommended by the food industries for consumer use.

** When cooking very large pieces of food: Your Outdoor Smoker can cook up to about 5-6 hours on a pan of charcoal. Turkeys or cuts of meat over 6 to 8 lbs. could take longer to cook. If you are going to cook large pieces of food, you will need to add more charcoal and water during the cooking period. Smoke Cooking Times are only approximate. NOTE: ELECTRIC COOKING TIMES COULD BE SHORTER THAN SHOWN ON CHART.