

This Owner's Manual is provided and hosted by [Appliance Factory Parts](#).



Meco 5031U4.181 Owner's Manual

[Shop genuine replacement parts for Meco 5031U4.181](#)



[Find Your Meco Grill Parts - Select From 46 Models](#)

----- Manual continues below -----

MECO®

CORPORATION



WATER SMOKER/GRILL

*For the Ultimate
Flavor Experience*

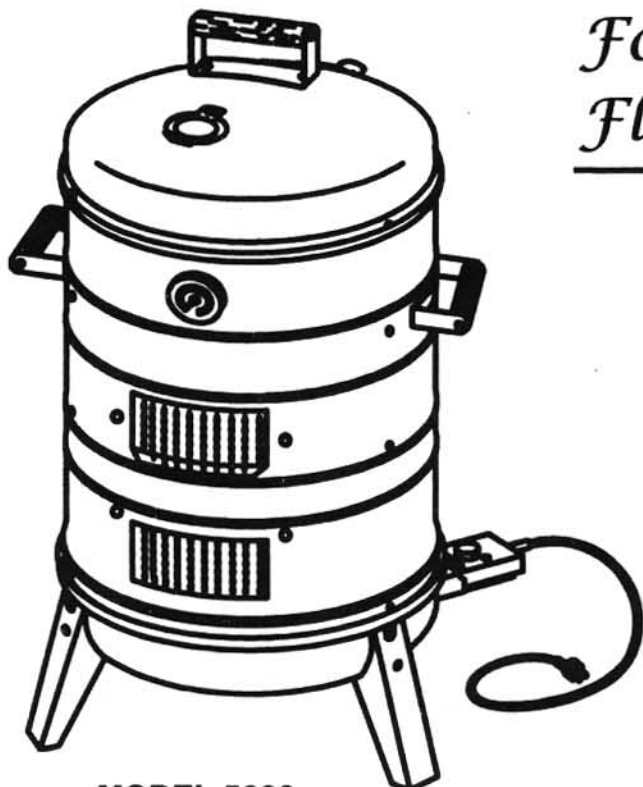

**MODEL 5030
ELECTRIC COMBO**

USE EITHER MODEL AS A WATER
SMOKER OR AS A PORTABLE GRILL

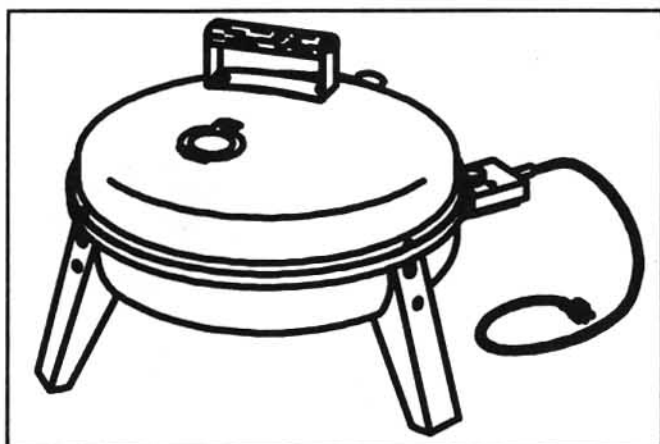

**MODEL 5031
CHARCOAL COMBO**

**EASILY CONVERTS
TO ELECTRIC**

ASSEMBLY AND USE MANUAL

P/N 03.5760.03
REV. 1/96

— NOTICE —

MECO STRIVES TO BE A QUALITY SUPPLIER OF CONSUMER PRODUCTS. IF WE HAVE INADVERTENTLY OMITTED ANY PARTS NEEDED FOR ASSEMBLY OR IF YOU NEED TROUBLESHOOTING INFORMATION, PLEASE CONTACT OUR CONSUMER SERVICE DEPT. MECO WILL SHIP REPLACEMENT PARTS MONDAY THROUGH FRIDAY WITHIN 24 HOURS. SATURDAY & SUNDAY ORDERS WILL SHIP THE NEXT WORKING DAY. THANK YOU FOR PURCHASING A MECO PRODUCT.

ASK FOR CONSUMER SERVICE DEPT.:

1-(800)-346-3256

(24 HOURS / 7 DAYS A WEEK)

1-(423)-639-1171 (TELEPHONE)

1-(423)-639-2570 (FAX)

call or write:

CONSUMER SERVICE DEPARTMENT

MECO CORPORATION

1500 INDUSTRIAL ROAD

GREENEVILLE, TN 37745 USA

IMPORTANT SAFEGUARDS

WARNING: FAILURE TO FOLLOW THESE SAFETY RULES MAY RESULT IN SERIOUS INJURY OR PROPERTY LOSS. READ AND FOLLOW INSTRUCTIONS CAREFULLY BEFORE USING GRILL.

CHARCOAL SAFEGUARDS

- ▲ **WARNING:** Do not use charcoal for indoor cooking or heating. Toxic carbon monoxide fumes may accumulate and cause death.
- ▲ **CAUTION:** Do not use gasoline, kerosene, or alcohol for igniting charcoal.
- ▲ **CAUTION:** Do not use "instant lighting" charcoal.
- ▲ **WARNING:** Keep small children away from your Grill to avoid burns.
- ▲ **CAUTION:** Open the Hood carefully when cooking. The hot air and steam trapped inside can burn.
- ▲ **CAUTION:** Use a drip pan under the Charcoal Smoker when using on a wood deck.

ELECTRIC SAFEGUARDS

1. Read all instructions.
2. Do not touch hot surfaces. Use handles, knobs, or wear proper gloves. Open Hood carefully when cooking to avoid burns from the hot air and steam trapped inside.
3. To protect against electric shock, do not immerse cord, plug, or Electric Element in water or any other liquid.
4. Do not leave element on without cooking.
5. Unplug Grill from outlet when not in use and before cleaning. Allow to cool before cleaning, or putting on or taking off parts. Do not clean this product with water spray or the like.
6. Do not operate any appliance with a damaged cord or plug, or after the appliance malfunctions or has been damaged in any manner. Return to the nearest authorized service facility for examinations, repairs or adjustment.
7. The use of accessory attachments not recommended by the manufacturer may cause injuries.
8. Do not let cord hang over the edge of table or counter, or touch hot surfaces.
9. Do not place cord on or near a hot glass or electric burner, or in a heated oven.
10. Extreme caution must be used when moving an appliance containing hot oil or other liquids.
11. To disconnect appliance, remove plug from outlet.
12. Do not use appliance for other than intended use.
13. Fuel, such as charcoal briquettes, is not to be used when Electric Element is in place.
14. Do not use gasoline, kerosene or alcohol for lighting charcoal.
15. Use only properly grounded 110-120 Volt outlet. Always attach plug to appliance first, then plug cord into the wall outlet. To disconnect, turn control to "off", then remove plug from wall outlet.
16. Do not use longer detachable power supply cord or extension cord unless absolutely necessary. However, they are available and if you must use one, the following care should be exercised in their use. Use only a grounding type, 3-wire 14 Ga. cord, with a marked electrical rating at least as great as the electrical rating of this appliance. The cord should be surface marked with the suffix letters "W-A" and bare a tag stating "Suitable For Use with Outdoor Appliances". Any plug connection to an extension cord should be arranged so that it will not drape over a countertop or tabletop where it can be pulled on or tripped over accidentally. Keep the length as short as possible.
17. Use a protective, weatherproof cover for outdoor storage or store indoors out of the reach of children.
18. The Model 1516.4 Control & 1519-4 Electric Cooking Elements are for use ONLY with MECO Models 5030/5031 Water Smokers.
19. Close supervision is necessary when any appliance is used by or near children.
20. **WARNING:** DO NOT USE CHARCOAL FOR INDOOR COOKING OR HEATING. TOXIC CARBON MONOXIDE FUMES MAY ACCUMULATE AND CAUSE DEATH.

SAVE THESE INSTRUCTIONS

MODEL 5030 ASSEMBLY INSTRUCTIONS

TOOLS NEEDED:Phillips screwdriver, 3/8" open-end wrench or pliers.

Step 1. For some helpful hints about how to put your new Combination Smoker/Grill together, read the next few pages before you start.

Step 2. Take all parts out of the box and lay them on a smooth, clean surface.

Step 3. Attach Leg (1) to Bowl (2) by hooking in 2-slots under oval hole and rotating it til top hole in Leg aligns with side hole in Bowl. At same time, install Lock Bracket (3) against inside of Bowl. Make sure the Bracket lip fits into the wide slot of the Bowl. Put Bolt (4) through hole in Leg, Bowl and Lock Bracket. Attach Lock Nut (5) and tighten. Repeat for other (2) Legs. Set Bowl up on Legs.

Step 4. Put Bolt (6) through hole next to rectangular opening in Bowl (2) and through oval hole in Cover Plate (7). Attach Acorn Nut (8), but only tighten so Cover Plate can slide within oval hole. (Cover Plate is standard on all models. When Element is removed and grill used for Charcoal, Cover plate covers rectangular opening by sliding to left and hooking lip inside Bowl.)

Step 5. Place Grease Cup (9) in bottom of Bowl. Slide Reflector Pan (10) under Lock Bracket Bolts and drop to bottom of Bowl. The straight edge on the Pan should clear

Bolt opposite Cover Plate. Install Electric Element (11) by inserting box shield through rectangular opening in Bowl (2) and letting Element rest on Reflector Pan. Put Bolt (6) from inside through round hole in Element shield tab and hole in Bowl. Attach Acorn Nut (8). With screwdriver, turn Bolt til it just begins to tighten in the Acorn Nut. Plug Element Control (12) into Element.

Step 6. Put Bolt (15) through Body Assembly (16). Attach Lock Nut (5) and tighten. Repeat for the other (2) Bolts and Lock Nuts around the bottom of Body Assembly.

Step 7. Put Bolt (6) through center hole of Body Assembly (16), and through hole of Pan Bracket (17). Attach Lock Nut (5) and tighten. Repeat for other (2) sets of Bolts, Pan Brackets and Lock Nuts around Body Assembly.

Step 8. Put Bolt (6) through top hole in Body Assembly and through Grid Bracket (18). Make sure long side of Grid Bracket is toward the bottom. Attach Lock Nut (5) and tighten. Repeat for other (2) Bolts, Grid Brackets and Lock Nuts around the Body.

Step 9. Place Handle Bracket (19) over one pair of holes at top of Body Assembly. (Arrange so the word 'MECO' is right-side up.) Attach with Bolts (6) and Lock Nuts (5) and tighten. Repeat for Handle Bracket on opposite side of Body Assembly.

| ITEM | PARTS LIST DESCRIPTION | PART # | QTY. | |
|------|---------------------------|----------|------|------|
| | | | 5030 | 5031 |
| 1 | Leg | 17168600 | 3 | 3 |
| 2 | Bowl | 175487-- | 1 | 1 |
| 3 | Lock Bracket | 17168900 | 3 | 3 |
| 4 | Bolt, 10-24 x 5/8" | 03020103 | 3 | 3 |
| 5 | Lock Nut 10-24 | 03039000 | 21 | 21 |
| 6 | Bolt, 10-24 x 3/8" | 03020101 | 16 | 16 |
| 7 | Cover Plate | 17547100 | 1 | 1 |
| 8 | Acorn Nut | 03500055 | 4 | 4 |
| 9 | Grease Cup | 03074501 | 1 | - |
| 10 | Reflector Pan 5030 | 17541000 | 1 | - |
| 11 | Electric Element | 03072701 | 1 | - |
| 12 | Element Control | 03072300 | 1 | - |
| 13 | Charcoal Pan 5031 | 17541100 | - | 1 |
| 14 | Charcoal Ring 5031 | 18575200 | - | 1 |
| 15 | Bolt 10-24 x 1" Phillips | 03020104 | 3 | 3 |
| 16 | Body Ass'y, | -- | 1 | 1 |
| 17 | Pan Bracket | 17167700 | 3 | 3 |
| 18 | Grid Bracket | 17546900 | 3 | 3 |
| 19 | Handle Bracket | 17165300 | 3 | 3 |
| 20 | Wood Handle | 03090000 | 3 | 3 |
| 21 | Screw, 8AB x 5/8" | 03042400 | 6 | 6 |
| 22 | Heat Indicator | 03160202 | 1 | 1 |
| 23 | Water Pan | 03070100 | 1 | 1 |
| 24 | Cooking Grid | 03522300 | 2 | 2 |
| 25 | Bolt 10-24 x 1" | 03574900 | 3 | 3 |
| 26 | Hood | 175472-- | 1 | 1 |
| 27 | Vent Damper | 171672-- | 2 | 2 |
| 28 | Hickory Chunk | 03500505 | 2 | 2 |
| 29 | Owners Manual | 03576003 | 1 | 1 |

Note:Specify color on Part # with(-) at end.

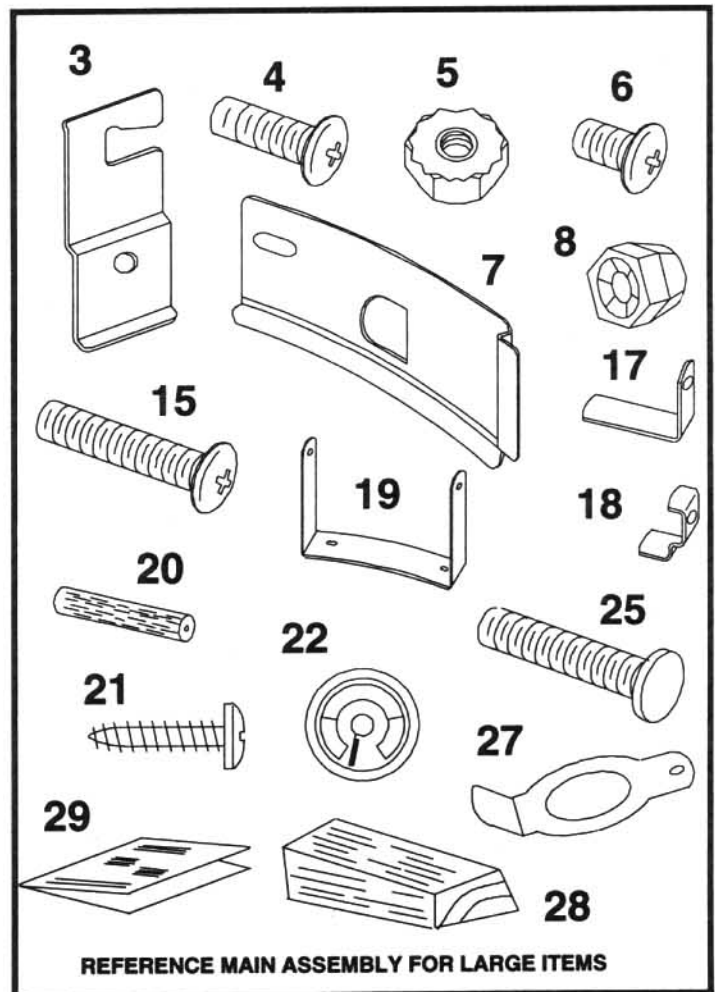

REFERENCE MAIN ASSEMBLY FOR LARGE ITEMS

Step 10. Place Wood Handle (20) inside of Handle Bracket (19). Put Wood Screw (21) through Handle Bracket into Hole in Wood Handle and tighten. Repeat for the other end of Handle. Attach other Wood Handle on opposite side of Body.

Step 11. Align bumps on Heat Indicator (22) with notches in large hole in Body Assembly (16). Insert Heat Indicator into hole and rotate it 1/4 turn till dial face is straight up. Assist the turning with your other hand inside Body Assembly.

Step 12. Pick up completed Body Assembly with Handles and set it down within the inside shoulder of Bowl Assembly. Rotate Body clockwise till bottom Lock Bolts (15) engage within the key way notch of the Lock Brackets (3) attached to the Bowl.

MODEL 5030 ELECTRIC

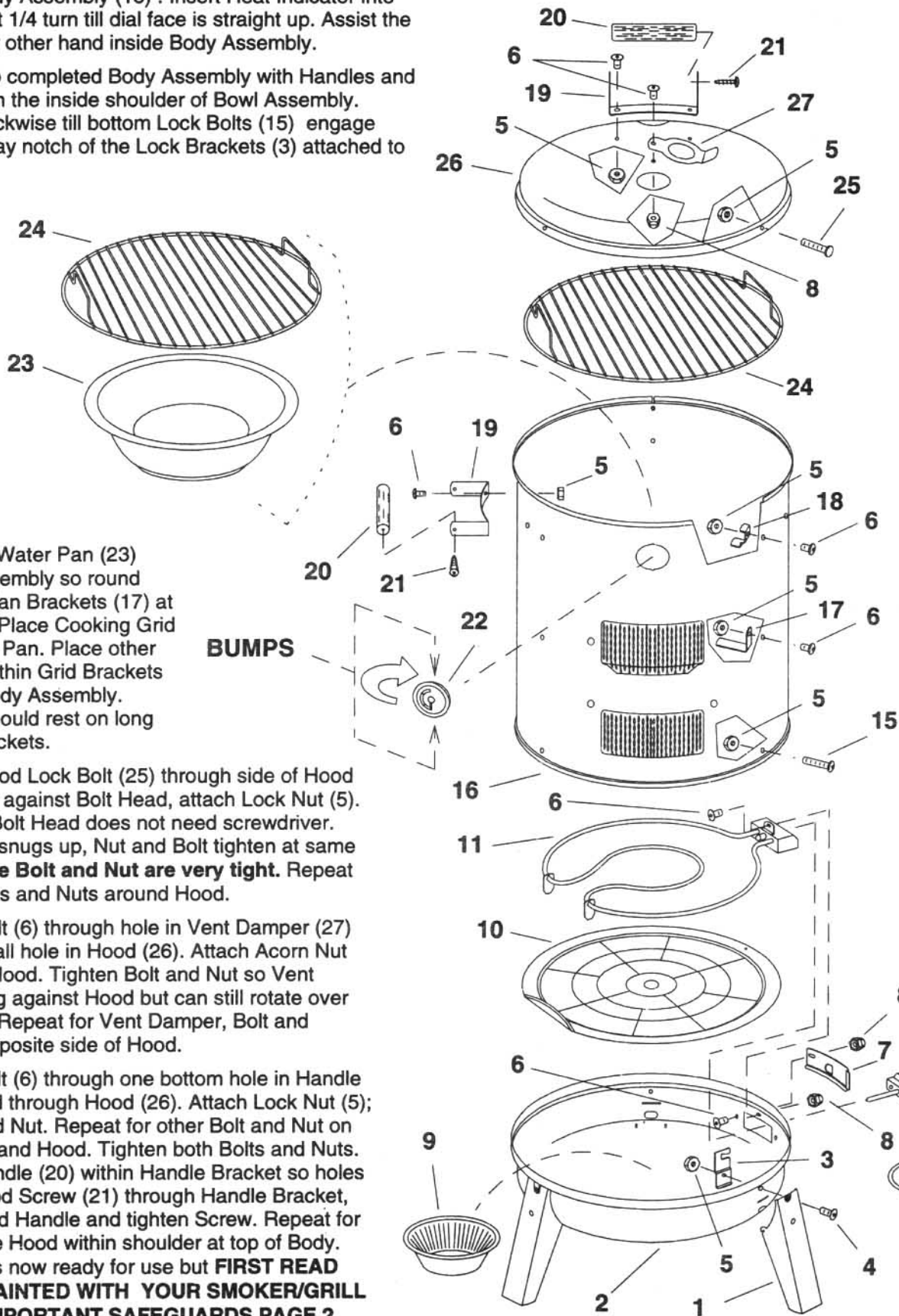

Step 13. Place Water Pan (23) inside Body Assembly so round edge rests on Pan Brackets (17) at center of Body. Place Cooking Grid (24) over Water Pan. Place other Cooking Grid within Grid Brackets (18) at top of Body Assembly. Cooking Grid should rest on long side of Grid Brackets.

Step 14. Put Hood Lock Bolt (25) through side of Hood (26). With finger against Bolt Head, attach Lock Nut (5). (Note: Smooth Bolt Head does not need screwdriver. When Lock Nut snugs up, Nut and Bolt tighten at same time.) **Make sure Bolt and Nut are very tight.** Repeat for other (2) Bolts and Nuts around Hood.

Step 15. Put Bolt (6) through hole in Vent Damper (27) and through small hole in Hood (26). Attach Acorn Nut (8) from inside Hood. Tighten Bolt and Nut so Vent Damper fits snug against Hood but can still rotate over large vent hole. Repeat for Vent Damper, Bolt and Acorn Nut on opposite side of Hood.

Step 16. Put Bolt (6) through one bottom hole in Handle Bracket (19) and through Hood (26). Attach Lock Nut (5); snug up Bolt and Nut. Repeat for other Bolt and Nut on Handle Bracket and Hood. Tighten both Bolts and Nuts. Place Wood Handle (20) within Handle Bracket so holes line up. Put Wood Screw (21) through Handle Bracket, into hole in Wood Handle and tighten Screw. Repeat for other side. Place Hood within shoulder at top of Body. Water Smoker is now ready for use but **FIRST READ GETTING AQUAINTED WITH YOUR SMOKER/GRILL PAGE 7 AND IMPORTANT SAFEGUARDS PAGE 2.**

MODEL 5031

ASSEMBLY INSTRUCTIONS

TOOLS NEEDED:Phillips screwdriver, 3/8" open-end wrench or pliers.

NOTE: Refer to Parts List & Hardware Diagram Page 3.

Step 1. For some helpful hints about how to put your new Combination Smoker/Grill together, read the next few pages before you start.

Step 2. Take all parts out of box and lay them on a smooth, clean surface.

Step 3. Attach Leg (1) to Bowl (2) by hooking in 2-slots under oval hole and rotating it til top hole in Leg aligns with side hole in Bowl. At same time, install Lock Bracket (5) against inside of Bowl. Make sure the Bracket lip fits into the wide slot of the Bowl. Put Bolt (4) through hole in Leg, Bowl and Lock Bracket. Attach Lock Nut (5) and tighten. Repeat for other (2) Legs. Set Bowl up on Legs.

Step 4. Put Bolt (6) through hole next to rectangular opening in Bowl (2) and through oval hole in Cover Plate (7). Attach Acorn Nut (8), but only tighten so Cover Plate can slide within oval hole. (Cover Plate is standard on all models. When Element is removed and grill used for Charcoal, Cover plate covers rectangular opening by sliding to left and hooking lip inside Bowl.)

Step 5. Slide Charcoal Pan (13) under Lock Bracket Bolts and drop to bottom of Bowl. The straight edge on the Pan should clear Bolt opposite Cover Plate. Place Charcoal Ring (14) on Charcoal Pan.

Step 6. Put Bolt (14) through Body Assembly (16). Attach Lock Nut (4) and tighten. Repeat for the other (2) Bolts and Lock Nuts around the bottom of the Body Assembly.

Step 7. Put Bolt (6) through center hole of Body Assembly (16), and through hole of Pan Bracket (17). Attach Lock Nut (5) and tighten. Repeat for other (2) sets of Bolts, Pan Brackets and Lock Nuts around Body Assembly.

Step 8. Put Bolt (6) through top hole in Body Assembly and through Grid Bracket (18). Make sure long side of Grid Bracket is toward the bottom. Attach Lock Nut (5) and tighten. Repeat for other (2) Bolts, Grid Brackets and Lock Nuts around the Body.

Step 9. Place Handle Bracket (19) over one pair of holes at top of Body Assembly. Arrange so the word 'MECO' is right-side up. Attach with Bolts (6) and Lock Nuts (5) and tighten. Repeat for Handle Bracket on opposite side of Body Assembly.

Step 10. Place Wood Handle (20) inside of Handle Bracket (19). Put Wood Screw (21) through Handle Bracket into Hole in Wood Handle and tighten. Repeat for the other end of Handle. Attach other Wood Handle on opposite side of Body.

Step 11. Align bumps on Heat Indicator (22) with notches in large hole in Body Assembly (16) . Insert Heat Indicator into hole and rotate it 1/4 turn till dial face is straight up. Assist the turning with your other hand inside Body Assembly.

Step 12. Pick up completed Body Assembly with Handles and set it down within the inside shoulder of Bowl Assembly. Rotate Body clockwise till bottom Lock Bolts (15) engage within the key way notch of the Lock Brackets (3) attached to the Bowl.

Step 13. Place Water Pan (23) inside Body Assembly so round edge rests on Pan Brackets (17) at center of Body. Place Cooking Grid (24) over Water Pan. Place other Cooking Grid within Grid Brackets (18) at top of Body Assembly. Cooking Grid should rest on long side of Grid Brackets.

Step 14. Put Hood Lock Bolt (25) through side of Hood (26). With finger against Bolt Head, attach Lock Nut (5) and tighten. (Note: Smooth Bolt Head does not need screwdriver. When Lock Nut snugs up, Nut and Bolt tighten at same time.) **Make sure Nut and Bolt are very tight.** Repeat for other (2) Bolts and Nuts around Hood.

Step 15. Put Bolt (6) through hole in Vent Damper (27) and through small hole in Hood (26). Attach Acorn Nut (8) from inside Hood. Tighten Bolt and Nut so Vent Damper fits snug against Hood but can still rotate over large vent hole. Repeat for Vent Damper, Bolt and Acorn Nut on opposite side of Hood.

Step 16. Put Bolt (6) through one bottom hole in Handle Bracket (19) and through Hood (26). Attach Lock Nut (5); snug up Bolt and Nut. Repeat for other Bolt and Nut on Handle Bracket and Hood. Tighten both Bolts and Nuts. Place Wood Handle (20) within Handle Bracket so holes line up. Put Wood Screw (21) through Handle Bracket, into hole in Wood Handle and tighten Screw. Repeat for other side. Place Hood within shoulder at top of Body. Water Smoker is now ready for use but **FIRST READ GETTING AQUAINTED WITH YOUR SMOKER/GRILL PAGE 7 AND IMPORTANT SAFEGUARDS PAGE 2.**

GETTING AQUAINTED WITH YOUR SMOKER/GRILL

LOOK AT WHAT YOU HAVE:

You now own a Combination Water Smoker and Portable Grill which can meet all your Barbequing needs in ONE unit. It's a:

1. **Water Smoker** for at home slow cooking of large meats such as turkeys, ham or game...

or in just a few seconds **without any tools** convert to a

2. **Portable Grill** for camping or picnic to cook steaks, hamburgers, or hot dogs.

Both Models 5030 Electric and 5031 Charcoal are CONVERTABLE. Also featured in these units is the Meco THREE-WAY LOCK which works whether you use it as a Smoker or a Portable Grill. Model 5031 Charcoal unit can also be converted to Electric Model 5030 with the purchase of Model 1519 Electric Element Kit. A Model 1511 Charcoal Kit is available for replacement or converting Electric to Charcoal.

No matter which way you go, versatility is there. You will enjoy your Smoker/Grill for a long time and within a short while you will be impressing your dinner company. (See Smoke Cooking Section Page 8 for details.)

USE AND CARE:

BREAK-IN the Element to remove the new appliance smell before cooking the first time. Plug in the Element, set the control on High and burn it for about 10 minutes with the Hood off.

Electric Cooking is simple and similar to cooking with charcoal. Cooking time varies slightly, but no lighter fluid or charcoal is needed. When using as Portable Grill, cook with Hood covered to preserve natural food juices and enhance smoke flavor. Cook hamburger-hot dog-steak favorites on High, and small cornish hens or the like on Low or Medium. When using as a Water Smoker you will need to cook on High unless you are only warming. Use a meat thermometer on whole meats when you can.

Note: Cooking times for use as an Electric Portable Grill are not specified because of various tastes and its outdoor nature. It is a more constant heat source than charcoal and should not be confused with an Indoor Electric Skillet.

Damper Vents control amount of smoke. Open Vents halfway to full for Charcoal, and just slightly for Electric. For extra smoke flavor, use hickory or mesquite chips sprinkled around Element coils. Small wood chunks may be placed on or touching the Element coils. Soak wood chips or chunks in water at least 30-60 minutes before cooking. Amount of chips or chunks vary to degree of smoke flavor you want and amount of food. (See Smoke Cooking Section Page 8.)

Clean-up is made easy by spraying Grid and Reflector Pan with cooking spray before cooking. For added protection, line Water Pan and inside of Bowl with aluminum foil. Make sure you do not cover any of the vents. When Grill has cooled down, wash Grid, Water Pan and outside of Smoker/Grill with warm soapy water. Wipe excess grease from inside the grill. The rest will be dark and smoky—just let it stay that way. **NEVER USE OVEN CLEANER.** Wash Charcoal Ring and Pan with warm soapy water. For the Electric unit, Loosen Wing Nut and Thumb Screw about 2 turns. Lift Element; remove and wash Reflector Pan and Grease Catcher. Wipe off the Element and Control. **DO NOT IMMERSE IN WATER.** Replace all the clean Charcoal or Electric parts. Re-tighten Element Thumb Screw and Wing Nut. Store the Smoker/Grill in an out-of-the-way spot. Cover with a plastic garbage bag if you wish.

TO CONVERT SMOKER TO PORTABLE GRILL; simply remove the Body Assembly section. Place one of the Cooking Grids on the Bowl Lock Bracket Bolts inside the Lock Brackets. Place the Hood on the Bowl. You now have a Portable Grill.

NOTE: BEFORE MOVING SMOKER/GRILL; lock Body to Bowl by turning Clockwise. Line up bottom Lock Bolts with Bowl Lock Bracket Bolts. This is the proper position for lifting and carrying Smoker. To unlock, turn counter-clockwise. When using as a Portable Grill, lock Hood to Bowl in same manner. **ALWAYS MAKE SURE BODY OR HOOD IS PROPERLY LOCKED BEFORE LIFTING IT.**

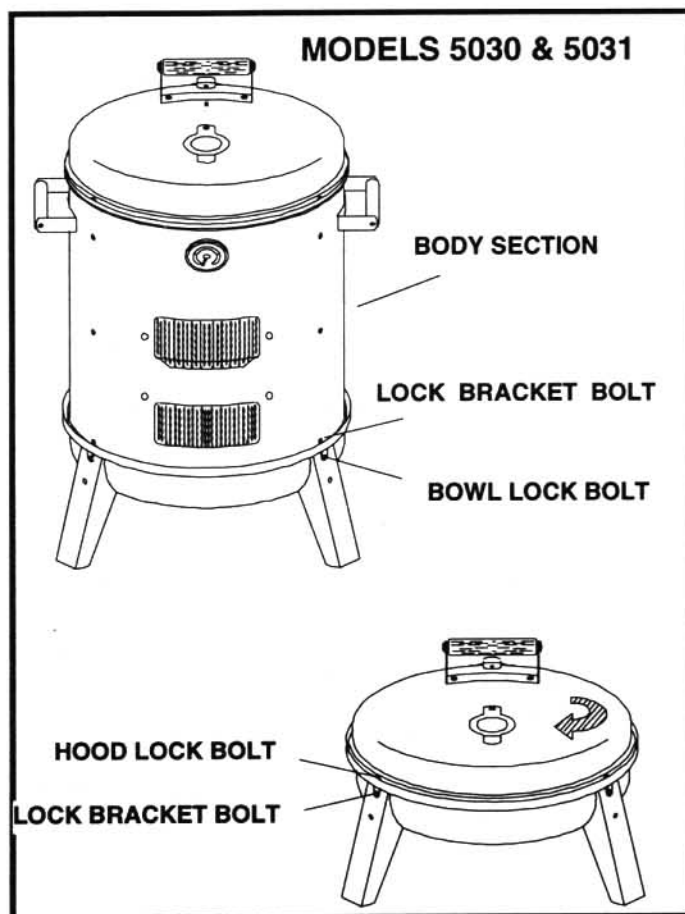

SMOKE COOKING

MODEL 5030 ELECTRIC:

STEP 1. Before you cook the first time make sure you "broke-in" the Electric Element to remove the new appliance smell. (Page 7) Make sure the Element is installed properly, then plug the cord into a grounded 110-120 Volt 15 Amp outlet. Turn the Control on High and warm up the Grill while you finish your preparations. Leave the Hood off.

STEP 2. When you are ready to cook, add wood chips or chunks (if you wish) around the Electric coils. (See WOOD Page 9.) When Smoke Cooking, cook with Control on High unless recipe calls for other temperature.

STEP 3. Lift the Body Section and place it on the shoulder inside the Bowl. Turn the Body clockwise to lock it to the Bowl. Put the Water Pan in place and fill with water. Use hot tap water if the temperature is 50 degrees or less. (Warm water otherwise.) Some recipes may use less water with other liquids such as soda, beer or wine.

STEP 4. Put the top Cooking Grid in place. Arrange food in a single layer with space between each piece so heat and smoke can penetrate. If double cooking, always put the smaller meat on the bottom grid.

NOTE: BEFORE USING YOUR ELECTRIC SMOKER; READ ELECTRIC SAFEGUARDS ON PAGE 2.

STEP 5. Put Hood on Body, open Vent Dampers just slightly and smoke for time given in the Quick Glance Cooking Chart (back page) or recipe.

STEP 6. If cooking more than **six hours**, you may need to add water to the water pan. Check the water level through the access door. Wear an insulated mitt, or use a barbecue tool, to lift the door up to its open position. If water is needed, use a watering can with a long spout. A plastic milk jug will work if you don't have one.

MODEL 5031 CHARCOAL:

Put Your Meco Water Smoker outside on a level surface out of traffic and away from trees or buildings. There won't be very much smoke but you may want to put the smoke away from open windows.

STEP 1. For easy clean up later, line the inside of the Bowl and Water pan with aluminum foil. Leave the Bowl vents open so the charcoal will get air.

CAUTION: Do not use "instant lighting" charcoal.

STEP 2. Put the Charcoal Pan and Ring in the bottom of the Bowl. Fill the Ring with good quality charcoal briquettes. (Approximately 10 pounds) Check the Quick Glance Cooking Chart on the back page for the right amount.

STEP 3. Sprinkle one 8 ounce cup of charcoal lighter fluid over the briquettes. Let the fluid soak into the briquettes for about one minute.

STEP 4. Light the charcoal with a match and let it burn for about 30 minutes or until the briquettes are covered with a grey ash. If you use an electric charcoal starter, omit the lighter fluid and follow electric starter instructions.

STEP 5. When ready to cook, add wood chunks (if you wish) on top of the charcoal . . . use long handled tongs. (See WOOD page 9.)

STEP 6. Lift the Body Section and place it on the shoulder inside the Bowl. Turn the Body clockwise to lock it to the Bowl. Put the Water Pan in place and fill with water. Use hot tap water if the temperature is 50 degrees or less. (Warm water otherwise.) Some recipes may use less water with other liquids such as soda, beer or wine.

STEP 7. Put the top Cooking Grid in place. Arrange food in a single layer with space between each piece so heat and smoke can penetrate. If double cooking, always put the smaller meat on the bottom grid.

STEP 8. Put Hood on Body and open Vent Dampers about half-way. Smoke for time given in the Quick Glance Cooking Chart (back page) or recipe. **DO NOT** lift the Hood except to check for doneness because it will slow down the cooking. Add at least 15 minutes to cooking time for each time you lift the Hood.. **DO NOT STIR CHARCOAL AFTER YOU START COOKING!**

STEP 9. If cooking more than **six hours**, you may need to add water or charcoal. Check water level and charcoal through the access door. Wear an insulated mitt, or use a barbecue tool, to lift the door up to its open position. If water is needed, use a watering can with a long spout. A plastic milk jug will work if you don't have one.

Add hot charcoal, or wood chunks, by placing them on the burning charcoal. Don't toss them in. That will just stir up ashes that will get onto your food. If you need to cook for a long time, start the additional charcoal in a separate container and add it after about twenty to thirty minutes.

STEP 10. If you wish, use the juices in the water pan to make Gravy: Skim off the fat and measure the juices. Use 1 tablespoon fat, 1 tablespoon flour and one cup juices for each cup of gravy.

STEP 11. Use coals that remain for Smoke Flavored Foods (page 11) or cover and let them burn out. When coals are cold, you can lift out any remaining briquettes to use another time.

STEP 12. Always dump the ashes after each use. Wash water pan and grid with hot suds or in dishwasher.

WARNING: Make sure none of the coals are still burning before you dump them.

NOTE: BEFORE USING YOUR CHARCOAL SMOKER, READ CHARCOAL SAFEGUARDS ON PAGE 2.

CHARCOAL:

Hardwood charcoal briquettes make the hottest, longest lasting fire. Look for quality. The cheapest charcoal is not a good buy if it does not burn well. Always close unused bags of charcoal by rolling the tops down tightly. Store charcoal in a dry place. Charcoal that's left out in the rain or dew will not burn well.

Most charcoal briquettes average about 14 briquettes per pound. Always use a least five pounds of charcoal. Bigger cooking jobs need more charcoal, so follow the recipes or the Quick Glance Cooking Chart on back page that tells how much charcoal to use.

WOOD:

The smokehouse flavor comes from the green or wet wood that you put on the glowing coals. If the wood isn't green or wet, it will burn instead of smoking. Use wood from deciduous trees (they shed their leaves in the winter) only, NOT from evergreen trees. Evergreens, such as pine, are resinous and will ruin the flavor and appearance of food. DO use hickory, apple, peach, pecan or other fruit or nut tree woods. Mesquite wood is popular in the Southwest; palmetto is used in the South and some Midwesterners use dried corncobs. Experiment with all of them.

You can buy or cut wood for smoking from several forms. Chips are often available in 1-1/2 or 2 pound bags. You'll usually find them right next to charcoal in the supermarket. Chunks of cross cut trees should be about 3-4 inches long and 1/2 inch diameter. The cooking chart and recipes call for one stick, chunk, or handful of chips but you can use whatever form you prefer. Chunks give the longest lasting smoke. Your own experimentation will help you determine how much to use to get the amount of smoke flavor you want.

To assure proper Electric Smoking performance, use HICKORY CHUNKS instead of chips. Place the chunks between the element sections so the chunks actually touch the element. If using wood chips, sprinkle them under and near the element coils.

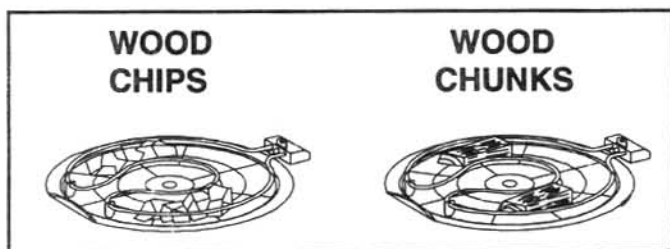

BARBECUING:

You can change your Water Smoker into a barbecue grill in less than a minute. Remove the Body section from the bowl. Remove the 5031 Charcoal Ring; add about 3 pounds of charcoal and light it as you normally would for smoke cooking. When ready to cook, spread charcoal out. Put a Cooking Grid on the screws in the side of the bowl. For 5030 simply turn the Control on. Now you are ready to cook steaks, burgers or other food which require high, fast heat. Add wood chips or chunks if you want smoke flavor. Cover with the Hood to hold in the heat and moisture.

ROASTING/BAKING:

You can cover cook foods at temperatures similar to a medium hot oven by cooking without water. Set up the grill (charcoal or electric) the same as you would for water smoking but omit the Water Pan, and don't add wood chips. Roasting is good for very thick steaks, chickens and small tender roasts such as tenderloins. Remember that roasting times are much shorter than water smoking times.

STEAMING:

You can cook foods with low, moist heat in your water smoker. Just don't add wood chips or chunks. You'll get great cooking in the same times as shown in the Cooking Chart but there won't be any smoke flavor.

TESTS FOR DONENESS:

Some recipes that follow and the Quick Glance Cooking Chart, give meat thermometer readings as test for doneness. Lift the hood to check meat thermometer only at the end of the minimum cooking time given in the chart.

Smoked foods do look a little different from oven or grill cooked foods, so your eye cannot always judge doneness. A meat thermometer is the only sure way to tell if a piece of meat is cooked the way you want it.

Smoked poultry, for instance, usually will look slightly pink, especially around the joints and just under the skin even though it is done. Pork, also will show pink color, even though it's well done.

Always be sure to insert the meat thermometer into the meat so the tip is in the center of the largest muscle, away from bone or fat.

USE A MEAT THERMOMETER

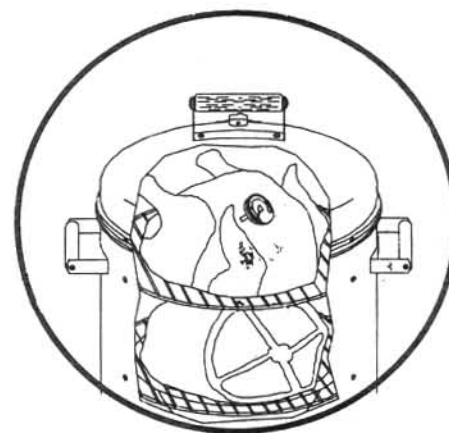

Use a MEAT THERMOMETER for judging the doneness of the meat. Whenever the outside air temperature is 70 degrees Fahrenheit or below, allow the meat to cook for at least the minimum time shown on Quick Glance Cooking Chart before opening the hood. The purpose of the heat indicator on the hood is to give only a relative indication of how the smoker is performing. The actual cooking temperature is influenced by many variables. You will have the most success in cooking by checking the actual temperature of the meat being cooked.

TIMING:

You'll notice that there are ranges of one to two hours in cooking times in the Chart and in the recipes. This is because there are so many factors that can speed up or, more often, slow down the rate of smoke cooking. Wind, type of charcoal, temperature of the food, outside temperature, relative humidity, number of times you lift the hood, temperature of water in the water pan, thickness and weight of food can all have an effect, so cooking times have to be approximate. There's very little chance that you will overcook food in your water smoker, except when barbecuing or roasting without the water pan. When the water pan is in place and full of water, it keeps the heat so low and even that, especially at the end of long cooking periods, food will stay hot and moist for several hours.

If the outside temperature is below 55-60 degrees F, if you live above 4000 feet, or if it is very windy (move smoker out of direct wind), allow extra time for cooking. If you forget to take the meat out of the refrigerator for half an hour or so before putting it on to cook, allow extra cooking time. Meat must be completely thawed before putting it on to cook. Don't forget to check the water pan after four-five hours of cooking time.

If your charcoal smoker is beginning to cool down or you need to cook for longer periods of time:

Model 5031. Start about 3-5 pounds additional charcoal in a separate container. When ready, slide the access door open using barbecue mitts or protective cloth. Add the charcoal briquettes with long handled tongs to the charcoal ring. Don't just throw them in . . . this will stir up ashes. Add hot water to the water pan if you need to.

SCHEDULING:

Long, slow smoke cooking is such a change from our usual hurry-up way of life that it takes some adjusting to. It's a good idea to set yourself a countdown so your food will be cooked before your scheduled meal time. Cooks that don't plan ahead may find themselves with a yard full of hungry and less than happy guests if the food comes out of the smoker two hours later than planned.

Base your countdown on the longest cooking time shown on the chart or recipe. Count backward from the time you want to eat, then add another hour to start your fire, take the meat out of the refrigerator to get the chill off, soak the wood chunks and generally get everything ready to cook. The first hour of preparation is the most work you'll have to do while smoke cooking.

WHAT IF..? Even the best planned schedule can go wrong, so here some tips for those rare occasions:

Try to always have some appetizers, or perhaps a salad to serve first to give you some flexibility on the serving time in case your food is not done on schedule.

If the food is cooking too slow and guests have consumed all your appetizers...try one of the following: Remove the

water pan to allow all the heat from the charcoal to get to the meat. If you're waiting for a large piece of meat or a large turkey, cut it into smaller sections; it won't be as juicy as if cooked whole but it will finish faster. If you have run out of charcoal, move the meat inside to a 400 F oven.

If the food has cooked faster than planned and is beginning to dry out... Baste the meat with juices from the water pan and wrap it in foil. Leave it on the cooking grid to stay warm until serving time. If serving time is more than an hour or so, put some ice into the water pan and fill it with cold water.

What if roasts don't look like oven cooked meats? Remember that water smoking isn't the same as oven roasting. Beef may look less crusty than if oven-cooked and it may be paler. Just brush it with gravy coloring, barbecue sauce, soy sauce or teriyaki sauce, then dig in and enjoy.

FOOD SAFETY:

A lot of what's called the "24 hour virus" is really food borne illness. A word to the wise can prevent discomfort to family and friends. Cleanliness is indeed a virtue. All utensils, all work surfaces and the cook must be clean. If you have a cold or the flu, wait until another day to cook. Guests are less likely to share your malady and you're better off resting.

Do not let foods stand around at room or outside temperature. Other than the half hour period we recommend for meats to come out of the refrigerator to warm up before cooking, rush all food from refrigerator to table and back again. Keep meats hot in your water smoker for second helpings, then cover and refrigerate immediately . . . don't wait until after dessert! The rule is: keep hot foods hot and cold foods cold and get them to those temperatures as soon as possible.

We recommend you cook turkeys unstuffed. Prepare the stuffing and wrap it in foil to cook along side the bird, if you wish. It takes so long for stuffing in the center of a large turkey to heat through that it's better to cook it separate.

TIPS FOR SUCCESS:

- .Always thaw meat thoroughly.
- .Let charcoal burn until it gets very hot . . . make sure the coals are glowing and covered with grey ash before cooking.
- .Let meat stand at room temperature at least one half-hour before cooking.
- .Do not lift hood to check for doneness until end of minimum cooking time given in charts.
- .Add more cooking time if:
 - It's windy or colder than 50 degrees F.
 - You lift the hood often.
 - You cook at high altitude.
- .Don't peek just to be sure the food is cooking. Look at the heat indicator, or feel the heat near the hood.

RECIPES FOR SMOKE COOKING

SMOKE FLAVORED FOODS

You can use the low, slow coals left at the end of cooking to flavor cheese, nuts, salt, seeds or other foods. After you've finished with the main cooking, remove the cooking grid and water pan. Add a few sticks, chunks or handfuls of soaked wood to the low coals. Put the water pan and cooking grid back in place. Put food on cooking grid, cover and let smoke flavor about 30-60 minutes for eggs and cheese or several hours for nuts, seeds and salt. Smoke flavor an 8-ounce piece of cream cheese or a same size piece of Cheddar, Monterey Jack or Colby Cheese. Put cheese on piece of foil. It will melt slightly around edges.

Or smoke flavor any whole nuts or seeds. Put nuts on piece of foil. Sprinkle with salt before smoking, if desired.

You can smoke-flavor hard-cooked eggs. Peel eggs and put on piece of foil. Smoke flavor 20 to 30 minutes, then chill. You can smoke-flavor salt, too. Use a shallow metal pan or tray made from foil. Sprinkle in a thin even layer of salt and smoke flavor several hours or until salt is amber colored.

SMOKED BEEF ROASTS

Serve with foil-cooked Italian green beans, water-pan-boiled new potatoes, a giant green salad and you've made a magnificent meal!

5-pound rolled and tied rib, rump, sirloin tip or round roast
Salt and Pepper
Magnificent Marinade or 1 package taco seasoning mix, spaghetti seasoning mix or beef stew seasoning mix or 3 cups red wine.
CHARCOAL: Level pan full
WOOD: 1 to 2 sticks, chunks or handfuls chips
Rub salt and pepper or any of the seasoning mixes into meat or marinate in Marinade or wine several hours at room temperature or overnight in refrigerator. Insert meat thermometer with tip in center of largest muscle. Let stand at room temperature while lighting fire. When coals are ready, add wood. Put water pan in place and fill with 5-1/2 quarts hot water or 4-1/2 quarts hot water plus marinade or wine. Put meat on cooking grid over water pan, fat-side up. Cover and smoke-cook to desired doneness about 4 hours for medium (160F). Reserve juices in water pan, skim off fat and serve juices with meat or thicken with gravy.

SUMPTUOUS SMOKED TURKEY

Experts agree smoked turkeys are more beautiful and flavorful than those cooked by any other method.

10-pound fresh or thawed frozen unstuffed turkey
Salt and Pepper
1 cup white wine, apple juice/cider or pineapple juice
1 tablespoon rosemary leaves
CHARCOAL: Level pan full
WOOD: 2 to 3 sticks, chunks or handfuls chips

Remove giblets and reserve for other use. Rinse turkey with cold water and sprinkle inside and out with salt and pepper. Insert meat thermometer in center of thickest part of thigh with tip away from bone. Let stand at room temperature while lighting fire. When coals are ready, add wood. Put water pan in place and fill with 5 quarts hot water. Add wine and rosemary leaves to water. Put turkey on cooking grid over water pan. Cover and smoke-

cook about 6 hours or until leg moves easily in socket. Check water pan after 3 to 4 hours cooking and add more hot water as needed. Reserve and strain juices from water pan to thicken for gravy, if you wish.

SMOKED APPLE FLAVOR PORK CHOPS

6-1" thick pork chops
2 quarts apple juice and 1 quart water in water pan
Applewood chunks or trimmings directly on element.
Smoke for 2 to 3 hours or until meat reaches 170F.
(Check liquid in pan after approximately 2 hrs. and add if needed).
Serve with applesauce and enjoy!

SMOKED GAME BIRDS

Pheasant, dove, quail, squab, Rock Cornish Hens are flavorful, rich and moist when smoke-cooked.
2 to 6 game birds (size will determine how many will fit on each level of grill)
Brine (1 gallon water and 1 cup salt)
Bacon slices
CHARCOAL: Rounded pan full
WOOD: 1 to 2 sticks, chunks or handfuls chips
Clean birds and pluck but do not skin. Soak in brine, if desired, refrigerate for several hours. Lift birds from brine, rinse with cold clear water and pat dry with paper towels. Brush with oil or, if birds are small, cover breasts with half-slice of bacon. Arrange birds on cooking grid over water pan full of hot water. Cover and Smoke-cook about 2 to 3 hours, depending on size of bird or until leg will move easily in socket.
MAKES: About 2 to 6 servings, depending on size of birds.

MAGNIFICENT MARINADE

For steaks, chops, chicken, ribs, almost any meat you like. Pour over meat in plastic bag, pan or bowl and refrigerate several hours or overnight, turning occasionally. Cook meat in water smoker, adding marinade to water pan.
1-1/2 cups salad oil
3/4 cup soy sauce
1/2 cup wine vinegar
1/3 cup lemon juice
1/4 cup Worcestershire sauce
2 tablespoons dry mustard
2-1/2 teaspoons salt
1 tablespoon coarsely ground pepper
2 teaspoons chopped parsley
2 cloves garlic, crushed
Combine all ingredients and mix well. Store in tightly covered jar in refrigerator or freezer if not used immediately.
MAKES: About 3-1/2 cups

WATER PAN POTATOES

Scrub but don't peel 1 pound medium-sized new potatoes, or quarter 4 to 6 large red or white potatoes. Slip potatoes into 4 quarts hot water in water pan, put in smoker over fire pan. Cover and cook about 1 hour or until done. You'll probably want to add potatoes to water pan for last hour of cooking time of meat, poultry or pork. Since liquid in water pan may have evaporated, be sure to add enough hot water to cover potatoes.
MAKES: About 6 servings.

ADD YOUR RECIPE HERE:

QUICK GLANCE COOK GUIDE

ALWAYS FILL WATER PAN WITH APPROXIMATELY 5-1/2 QUARTS HOT WATER FROM TAP UNLESS RECIPE

INDICATES OTHER MEASUREMENT.

| Food and Weight | Amount of Charcoal | Amount of Wood Chunks (See Page 9) | Temperature or Test for Doneness* | Smoke Cooking Time(Hours) | Number of Servings Per lb. |
|--|--------------------|------------------------------------|---|----------------------------|----------------------------|
| BEEF, Venison or Other Game Animal | | | | | |
| Boneless Roasts | | | | | |
| 3-4 lbs. | level | 1 | 140 degree F rare | 3-4 | 3-4 |
| 5-7 lbs. | level full | 1 | 160 degree F medium | 5-6 | |
| 8-10 lbs. | heaping | 2 | 170 degree F well | 7-9** | |
| CHICKEN | | | | | |
| Fryers(2-2 1/2 lbs. ea.) | | | | | |
| 1 to 3 whole, split or cut up | rounded | 1 | 180 degree F or leg will move easily in socket | 4-5 | 3-4 |
| Roasters (5 lbs.) 1 or 2 | rounded to heaping | | | 6-8 | 3-4 |
| FISH | | | | | |
| Fillet, full grill | level | 1 | flakes when forked | 2-3 | 3-4 |
| Steaks | level | 1-2 | | 2-3 | |
| Whole Pan Fish | level | 1-2 | | 2-3 | |
| Whole, large, 6 lb. | rounded | 1-2 | | 3-5 | |
| GAME | | | | | |
| Small birds (dove, quail, squab, pheasant, duck) | rounded | 2 | leg will move easily in socket | 3-5 | 1 to 3 |
| HAM | | | | | |
| Cooked, all sizes | level | 1-2 | 130 degree F | 3-5 | 3-4 |
| Fresh, 10 lb. | heaping | 2-3 | 170 degree F | 7-10** | |
| LAMB | | | | | |
| Leg or shoulder roasts 5-7 lb. | rounded | 1-2 | 140 degree F rare 160 degree F rare 175 degree F done | 5-7** | 3-4 |
| LOBSTER TAILS | | | | | |
| Full grill | level to rounded | 1-2 | flesh white and firm | 1-2 | 2 |
| PORK | | | | | |
| Chops, 6-8 lb. (1" thk) | rounded | 1 | 170 degree F | 3-4 | 3-4 |
| Roasts, 3-5 lb. | rounded | 1 | 170 degree F | 5-7 | |
| Roasts, 5-7 lb. | heaping | 2 | 170 degree F | 7-8** | 2 |
| Ribs, 5 lb. | rounded | 1-2 | well done, meat pulls away from bone | 4-6 | |
| SAUSAGE | | | | | |
| Links, full grill | level to rounded | 1-2 | well done, 170 degree F for cook before eating pork sausage | 3-5 for cook before eating | 3-4 |
| SHRIMP | | | | | |
| | level | 1 | flesh white and firm | 1-2 | 3 |
| TURKEY (Unstuffed) | | | | | |
| 8-12 lb. | level | 2 | 180 degree F or leg will move easily in socket | 7-9** | 2-3 |
| 13-20 lb. | heaping | 2-3 | | 10-12** | |

* Temperatures are those recommended by the food industries for consumer use.

** When cooking very large pieces of food: Your Outdoor Smoker can cook up to about 5-6 hours on a pan of charcoal. Turkeys or cuts of meat over 6 to 8 lbs. could take longer to cook. If you are going to cook large pieces of food, you will need to add more charcoal and water during the cooking period. Smoke Cooking Times are only approximate. NOTE: ELECTRIC COOKING TIMES COULD BE SHORTER THAN SHOWN ON CHART.