

F59A Console 3-Speed Electronic Air Cleaner

The F59A Console Electronic Air Cleaner cleans the air in enclosed spaces such as offices or homes. A 3-speed fan draws room air through an electronic cell and activated carbon filter to remove dust, lint, pollen, tobacco smoke, cooking smoke and household odors.



- Furniture styled wood-grained cabinet.
- Circulates and cleans approximately 4400 ft³ [125m³] of air 4-1/2 times an hour. Typically this is a 25 by 22 ft [8 by 7m] room. Two or more F59A units may be used in larger rooms.
- Up to 90 percent air cleaning efficiency as measured according to the National Bureau of Standards Dust Spot Method using atmospheric dust, and the American Society of Heating, Refrigerating, and Air-Conditioning Engineers Standard 52-76.
- Suitable for commercial or residential use.
- Three-speed motor-driven fan circulates up to 330 cfm [560 m³/hr].
- Interlock switches prevent operation when cover is removed.
- Neon light indicates electronic air cleaner operation.
- Powered from standard grounded outlet.
- Electronic cell is easily removed for cleaning.
- Prefilter screens out large particles such as dust or lint.
- Activated carbon postfilter removes gaseous contaminants and odors.
- Optional casters allow easy movement of electronic air cleaner.

CONTENTS

<i>Specifications</i>	2
<i>Ordering Information</i>	2
<i>Setup and Operation</i>	3
<i>Service</i>	3
<i>Electrical Troubleshooting</i>	5
<i>Parts List</i>	10

Specifications

IMPORTANT: *The specifications listed in this publication do not include normal manufacturing tolerances. Therefore, this unit may not exactly match the listed specifications. Also, this product is tested and calibrated under closely controlled conditions, and some minor differences in performance can be expected if those conditions are changed.*

MODEL: F59A includes cabinet, 1 electronic cell, three-speed propeller fan, 1 carbon postfilter, 1 prefilter and a solid state power supply.

AMBIENT TEMPERATURE RANGE: 40° F to 100° F [4° C to 38° C].

EFFICIENCY: 90% efficiency rating based on National Bureau of Standards Dust Spot Method using atmospheric dust and American Society of Heating, Refrigerating, and Air-Conditioning Engineers Standard 52-76.

CLEAN AIR DELIVERY RATINGS:

	cfm	m ³ /hr
Dust	288	489
Tobacco Smoke	270	459
Pollen	239	406

CAPACITY:

Fan Speed	cfm	m ³ /hr	eff. %
High	330	560	80
Medium	265	450	85
Low	200	340	90

NEON LIGHT: Located next to three-speed switch. Indicates presence of high voltage power.

DIMENSIONS:

Cell: 16 x 12-1/2 in. [406 x 318 mm].

Cabinet: 19-1/2 x 13-7/8 in. x 17-1/8 in. [496 x 352 x 435 mm].

Prefilter, Carbon Postfilter: 12-7/8 x 16-1/4 in. [327 x 413 mm].

ELECTRICAL RATINGS:

Nominal Current and Power Consumption (max):

Fan Speed	120 Vac, 60 Hz		220 Vac, 50 Hz	
	A	W	A	W
High	1.0	110	.60	120
Medium	.74	80	.45	70
Low	.65	65	.35	55

INTERLOCK SWITCH: Interrupts supply circuit to unit when cover is opened.

CABINET: Particle board covered with wood-grained vinyl. Available in walnut or light oak finish (light oak not available in Canada).

WEIGHT: 45 lb [20 kg] shipping; 37 lb [17 kg] device including cell. Cell weighs 8 lb [4 kg].

ACCESSORIES: See Parts List.

UNDERWRITERS LABORATORIES INC.: Listed, File No. E64835 (120 Vac, 60 Hz units).

CANADIAN STANDARDS ASSOCIATION: Certified, File No. LR36354 (F59A1026 only).

Fig. 1—F59A components.

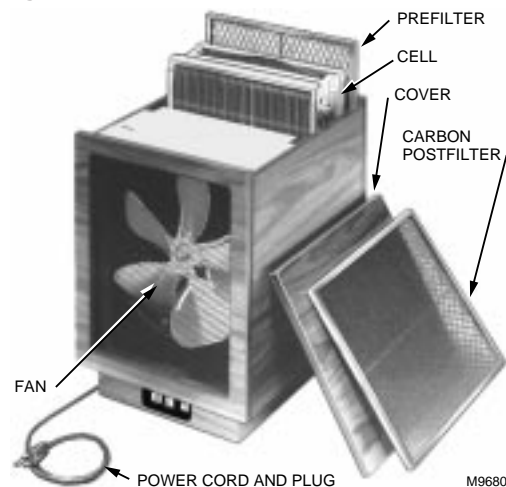

Ordering Information

When purchasing replacement and modernization products from your TRADELINE® wholesaler or your full service distributor, refer to the TRADELINE Catalog or price sheets for complete ordering number, or specify—

1. Order number.
2. Cabinet color—walnut or light oak (light oak not available in Canada).
3. Voltage.
4. Accessories, if required.

If you have additional questions, need further information, or would like to comment on our products or services, please write or phone:

1. Your local Honeywell Home and Building Control Sales Office (check white pages of your phone directory).
2. Home and Building Control Customer Logistics
 Honeywell Inc., 1885 Douglas Drive North
 Minneapolis, Minnesota 55422-4386 (612) 951-1000

In Canada—Honeywell Limited/Honeywell Limitee, 740 Ellesmere Road, Scarborough, Ontario M1P 2V9. International Sales and Service offices in all principal cities of the world. Manufacturing in Australia, Canada, Finland, France, Germany, Japan, Mexico, Netherlands, Spain, Taiwan, United Kingdom, U.S.A.

Setup and Operation

WHEN USING THIS PRODUCT...

Read these instructions carefully. Failure to follow them could damage the product or cause a hazardous condition.

UNPACK ELECTRONIC AIR CLEANER

Check that all components are included. The electronic air cleaner is shipped assembled. See Fig. 1.

SET UP ELECTRONIC AIR CLEANER

- Position the F59A so:
 - the airflow in and out of the air cleaner is not blocked or partially obstructed.
 - the discharge air does not cause uncomfortable drafts for any occupant.
 - the power cord does not interfere with normal occupant traffic.
- Remove and discard the cardboard liner next to the electronic air cleaner cell.
- Remove the cell and carbon postfilter from the cabinet; remove and discard the plastic cover from the carbon postfilter.
- Replace the cell and the carbon postfilter. Make sure cell is placed correctly, with directional arrows pointing toward center of air cleaner cabinet. The cell directional arrow is located on the side of the cell. The prefilter and carbon postfilter should be placed with the wire mesh toward the center. See Fig. 2.
- Plug power cord into standard grounded outlet.

OPERATION OF ELECTRONIC AIR CLEANER

- Select desired airflow rate with three-speed power switch—LO, MED or HI. For maximum air cleaning

Fig. 2—Make sure cell and filters are placed correctly.

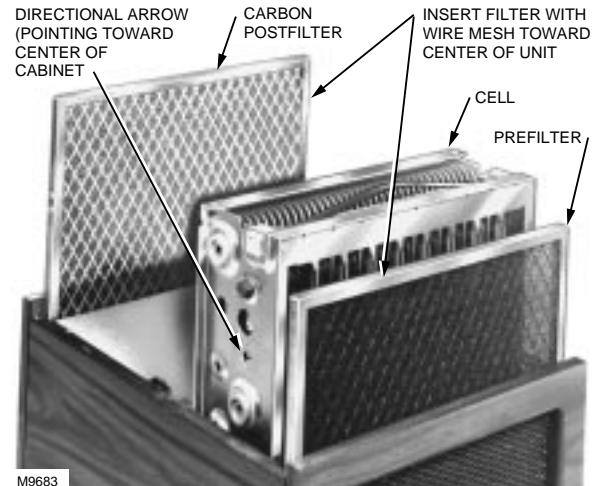

benefit, leave switch on HI at all times. For quiet operation, use LO setting. Neon light and fan should be on whenever air is running.

- Move power switch to OFF to turn off electronic air cleaner; neon light and fan will go off.

NOTE: An arcing (snapping) sound may be heard occasionally as air cleaner operates. This sound means air cleaner is working as it should, collecting large airborne dust particles.

Service



CAUTION

**SHARP EDGES.
CAN CAUSE PERSONAL INJURY.**

Handle the cell carefully to avoid cuts from the sharp metal edges.

CLEANING THE CELL AND PREFILTER

Clean the cell and prefilter regularly—every one to six months. Variables such as number of occupants, pets, activities and smoking will determine how often cleaning is required. Use the wash reminder schedule included with the air cleaner to help establish and maintain a regular cleaning schedule.

The cell can be washed in many automatic dishwashers, by soaking in a tub or a do-it-yourself coin operated car wash. The prefilter can be vacuumed, brushed or soaked in a tub. Do not wash the filter in the dishwasher or carwash.

Automatic Dishwasher



CAUTION

**BURN HAZARD.
CAN CAUSE PERSONAL INJURY.**

Allow the cell to cool in the dishwasher at the end of the wash cycle or wear protective gloves to avoid burns. Hot water can accumulate in the tubes supporting the collector plates. Tip the cell so these tubes will drain.

IMPORTANT:

- Check you dishwasher owner manual. Some manufacturers do not recommend washing electronic cells in their dishwasher.
- If the dishwasher has upper and lower arms, carefully position the cell to allow good water circulation.

- Be careful to avoid damaging or bending the cell plates when placing the cell in the dishwasher. If bent, arcing will result.
- A very dirty cell, especially from tobacco or cooking smoke, can discolor the plastic parts and lining of the dishwasher. The discoloration is not harmful. To minimize it, wash the cell more frequently or try a different brand of detergent.
- Do not allow the dishwasher to run through the dry cycle. This will bake on any contaminants not removed during the wash cycle and reduce air cleaner efficiency.

1. Put the cell on the lower rack of the dishwasher with the directional arrow pointing up. It may be necessary to remove the upper rack. Do not block water flow to the upper arm, if provided on dishwasher.

2. Using the detergent that works best for normal dishwashing, allow the dishwasher to run through the complete wash and rinse cycle. Do not use the dry cycle. To avoid burns, let the cell cool completely before removing, or wear protective gloves when removing the cell. Remember that water may be trapped in the tubes that support the collector plates. Tip the cell so these tubes can drain.

3. Wipe the ionizer wires and contact board on end of cell with a small, damp cloth, using your thumb and forefinger.

4. Inspect the dishwasher. You may wish to rerun the wash and/or rinse cycle with the dishwasher empty if you see dirt or residue from washing the cell. If dirt or residue seems excessive, wash the cell more often or try a different detergent.

5. Inspect the cell for bent plates; bend back to normal to prevent arcing.

Soaking in Tub



CAUTION

HAZARDOUS CHEMICAL. CAN CAUSE PERSONAL INJURY.

Do not splash the detergent solution in eyes. Wear rubber gloves to avoid prolonged detergent contact with skin. Keep detergent and solution out of reach of children.

NOTE: Always wash the cell first, then the prefilter, to keep heavy prefilter lint from getting caught in the cell.

1. Use a container such as a laundry tub or trash container that is large enough to hold the cell. Sharp corners on the cell can scratch the surface of a bathtub.

2. Dissolve about 3/4 cup automatic dishwashing detergent in enough hot water to cover the cell. If the detergent does not dissolve readily, or forms a scum on the water, try another brand, or use softened water.

3. After the detergent has completely dissolved, place the cell in the container and let soak for 15 to 20 minutes. Agitate up and down a few times, and remove.

4. Next, wash the prefilter the same way. Empty and rinse the wash container.

5. Rinse the cell with a hard spray of very hot water; rinse the tub clean, then fill the tub with clean hot water and soak for 5 to 15 minutes. Rinse until water draining from the cell no longer feels slippery. Rinse the filter with a gentle spray of hot water.

6. Soak cell and filter in a final clear water rinse for ten minutes.

7. Wipe the ionizer wires and contact board on end of cell by using your thumb and forefinger and holding a small, damp cloth.

Car Wash

Use the hand sprayer at a coin-operated car wash to wash the cell. Hold the nozzle at least 2 ft [0.6m] away from the unit to avoid damage from the high pressure stream of water. Follow the same sequence of wash and rinse as recommended for cars. However, do not wax the cell. Rinse until the water draining from the cell no longer feels slippery.

REINSTALLING CELL, PREFILTER AND CARBON POSTFILTER

- Inspect the cell for broken ionizer wires and bent collector plates. Repair as necessary.
- Slide the dry filter into the filter guides, with directional arrow pointing toward the center of the electronic air cleaner cabinet. The directional arrow is very small, and is located on the end of the filter frame. See Fig. 2.
- Gently vacuum the inside and outside of the air cleaner cabinet with the brush attachment of vacuum cleaner, or dust with a soft cloth.
- Slide in the dry cell so the directional arrow (located on the side of the cell) points toward the center of the air cleaner cabinet.
- Replace the carbon filter if necessary. This filter slides in or out of the guides easily.
- Replace the cover on the cabinet. The metal tab on the cover must fit in the slot at the end of the cabinet, and the interlock under the cover must connect with the air cleaner cabinet for operations. See Fig. 3.

Fig. 3—Cover must fit correctly for operation.

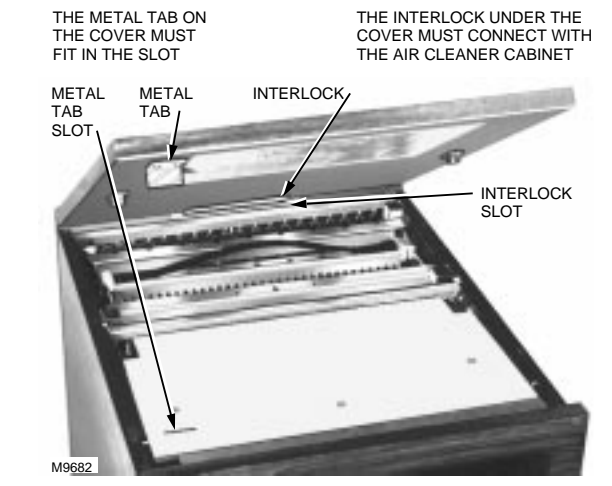

- Turn on the air cleaner. If the cell and filters are wet, the neon light may not come on; you may also hear arcing. If the arcing is annoying, simply turn off the air cleaner for two to three hours or until the cell is dry. Remove wet cell to hasten drying.

IONIZER WIRE REPLACEMENT

Broken ionizer wires can cause a short to ground, often resulting in visible arcing or sparking. The cell should not be used until the pieces of broken wire are removed. It can

Fig. 4—Install new ionizer wire by hooking eyelets over spring connectors.

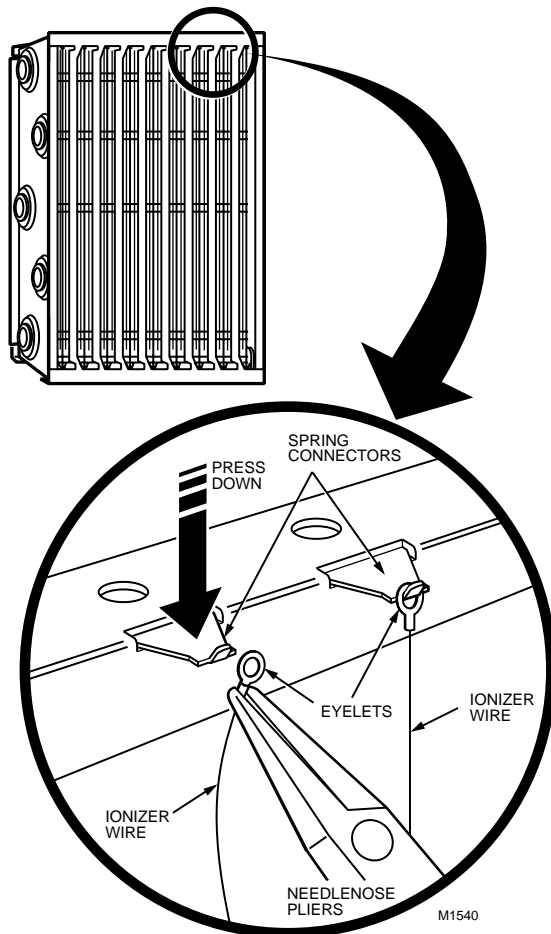

be used temporarily with one wire missing, although the wire should be replaced as soon as possible. See the Parts List, for order number. Replacement wires are supplied cut to length with eyelets on both ends for easy installation. To install:

- Hook the eyelet on one end of the wire over the spring connector on one end of the cell. See Fig. 4. Be careful to avoid damaging the spring connector or other parts of the cell.
- Hold the opposite eyelet with a needlenose pliers and stretch the wire the length of the cell. Depress the opposite spring connector and hook the eyelet over it.

OILING THE FAN MOTOR

Oil the fan motor once a year for smooth operation:

- Turn off air cleaner switch; unplug power cord.
- Remove cover and cell.
- Put two drops of electric motor oil in each of two oil indentations in fan motor. See Fig. 5.
- Replace cell with directional arrow (on side of cell) pointing toward center of air cleaner cabinet; replace carbon filter.
- Plug in power cord; turn on the air cleaner again.

Fig. 5—Oil fan motor yearly.



Electrical Troubleshooting



WARNING

**ELECTRIC SHOCK HAZARD.
CAN CAUSE PERSONAL INJURY OR
EQUIPMENT DAMAGE.**

The following procedures expose hazardous live parts. Disconnect power supply between checks and proceed carefully.



CAUTION

The following instructions are for use by qualified personnel only.

TOOLS AND EQUIPMENT

Troubleshooting the electronic air cleaner requires only a few tools:

- Needlenose pliers (for stringing ionizer wires).
- Test meter with high voltage probe (10 kV minimum).

TROUBLESHOOTING PROCEDURE



CAUTION

**ELECTRIC SHOCK HAZARD.
CAN CAUSE PERSONAL INJURY.**

Always turn off power before troubleshooting.

The troubleshooting chart shows how to quickly isolate a problem in the air cleaner. See Figs. 6 through 10.

The solid state power supply assembly provided in this air cleaner has no field-serviceable components. If troubleshooting indicates a power supply assembly problem, replace the entire power supply assembly. See Parts List section, for order number.

Fig. 6—Troubleshooting the F59A.

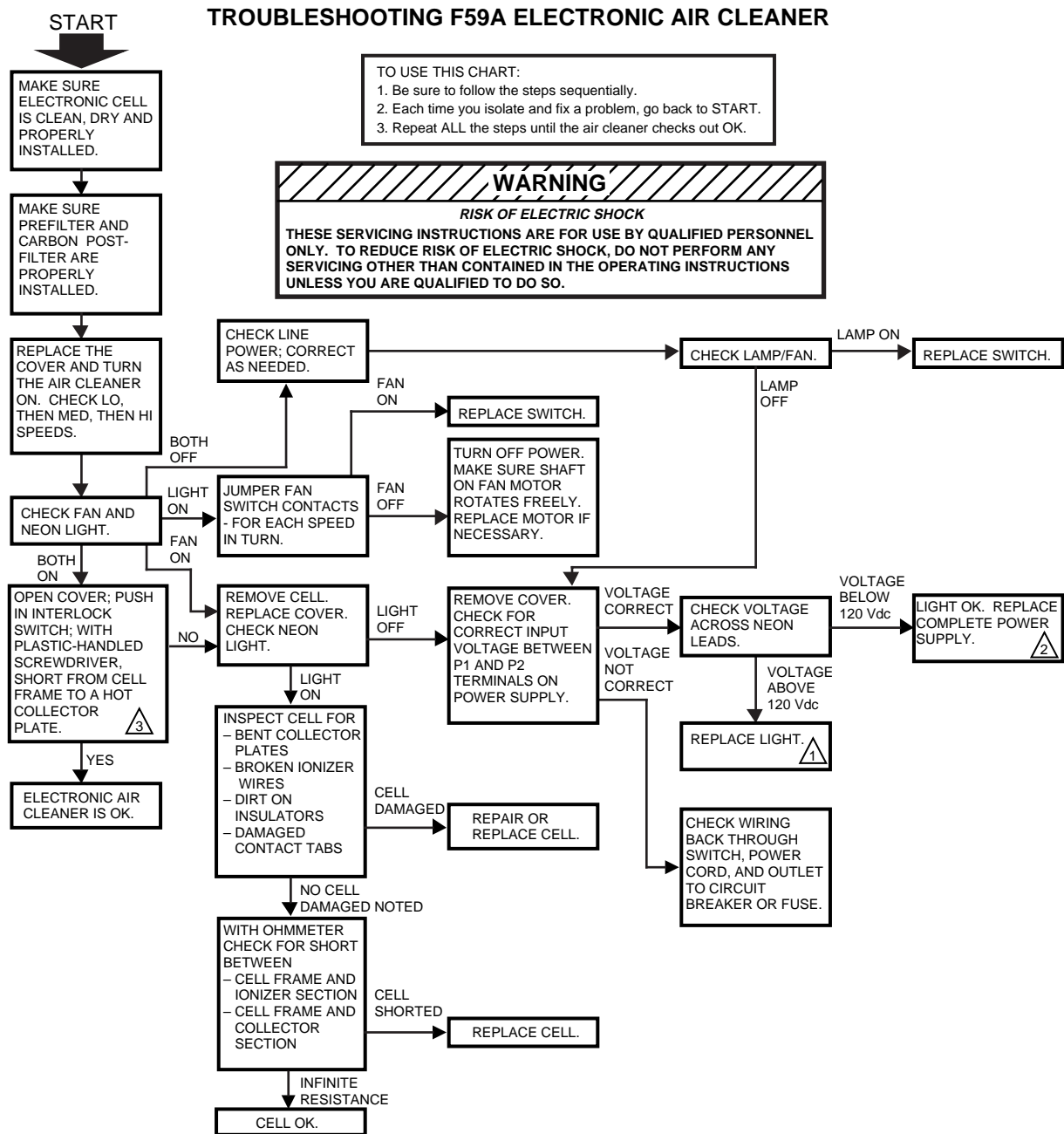

1 NEON LIGHT MUST BE REPLACED TO ENSURE PROPER AIR CLEANER OPERATION.

2 ELECTRONIC COMPONENTS ON POWER SUPPLY BOARD ARE NOT FIELD REPLACEABLE. ATTEMPTED SERVICE WILL DAMAGE BOARD.

3 A HIGH VOLTAGE METER CAN BE USED TO MEASURE IONIZER AND COLLECTOR VOLTAGE.

M1312B

Fig. 7—Push screwdriver down to close interlock switch (left); short from cell frame to hot collector plate to product arcing (right) as instructed in Fig. 6.

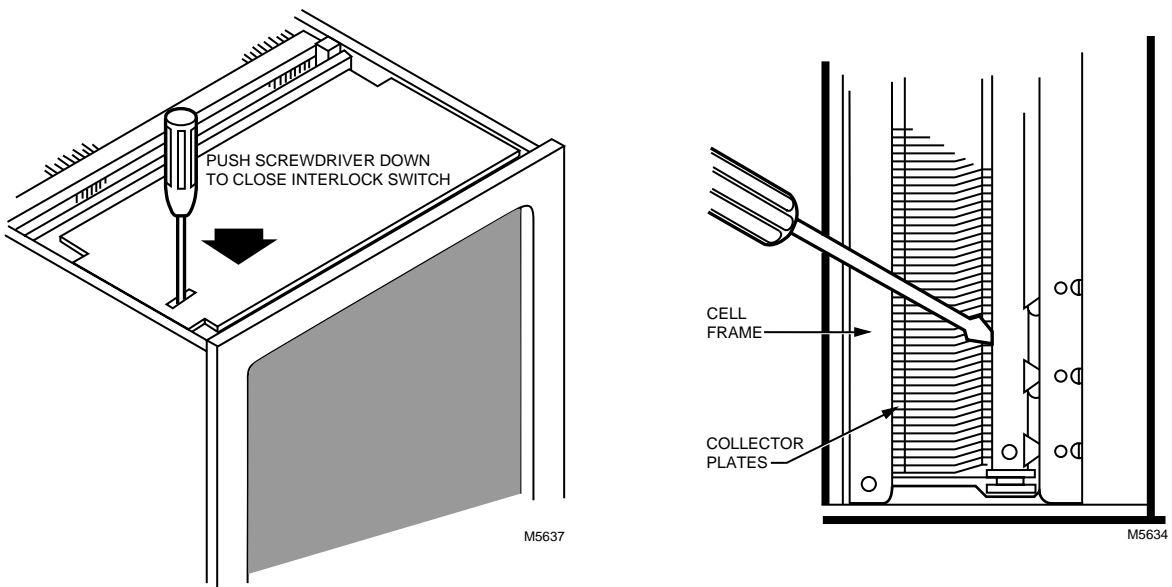

Fig. 8—Internal schematic for 120 Vac, 60 Hz F59A.

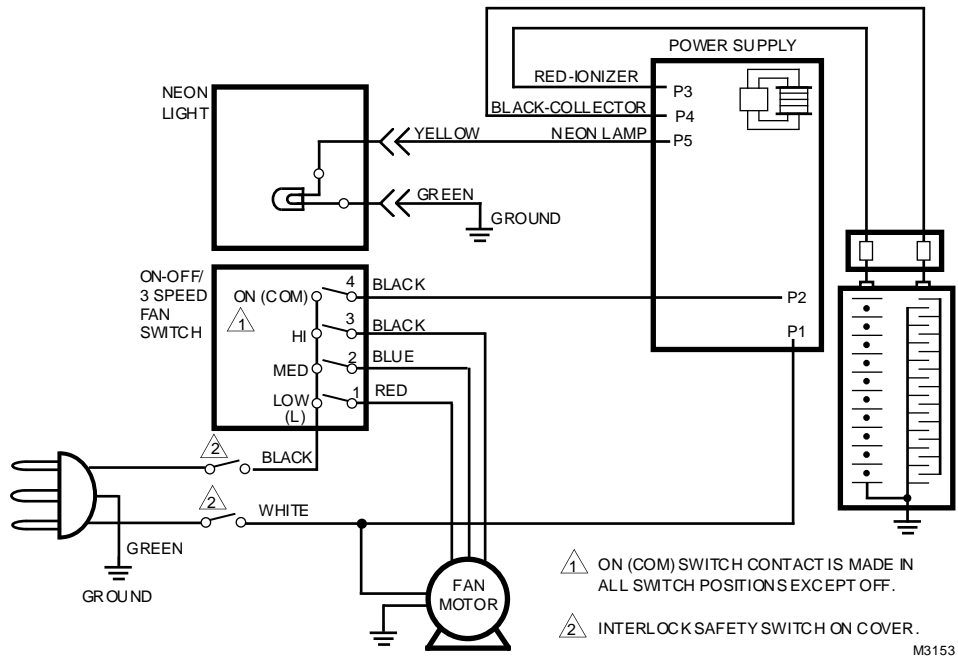
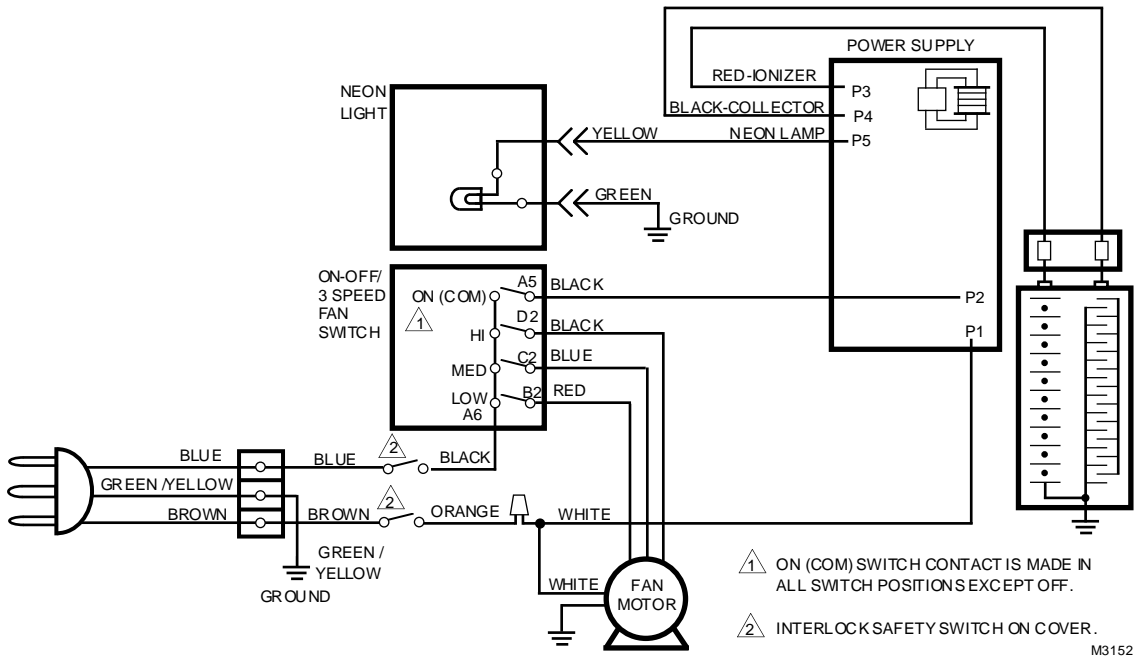

Fig. 9—Internal schematic for 220 Vac, 50 Hz F59A.



When measuring high voltage, use a good quality multi-meter and HV probe. When measuring ionizer and collector voltage, they should be between 6900 and 7800 Vdc.

REDUCING OZONE ODOR



CAUTION

ELECTRIC SHOCK HAZARD. CAN CAUSE PERSONAL INJURY.

Always disconnect power before working on power supply.

Only a trained service technician should perform the following procedure.

The electronic air cleaner generates a small amount of ozone in normal operation. During the first week or two of operation, the amount may be higher because of sharp edges on some of the new high voltage metal parts. Normal use dulls these edges in a short time.

The average person can detect the odor of ozone in concentrations as low as 0.003 to 0.010 parts per million (ppm). The electronic air cleaner contributes 0.005 to 0.010 ppm of ozone to the indoor air. The U.S. Food and Drug Administration and Health and Welfare Canada recommend that indoor ozone concentration should not exceed 0.050 ppm. As a comparison, the outdoor ozone level in major cities is sometimes as high as 0.100 ppm. However, if desired, the ozone generated by the air cleaner can be reduced by clipping out the J2 jumper on the power supply. This will reduce ozone production about 20 to 25 percent, and reduce efficiency about 7 to 10 percent depending on actual airflow delivered by the furnace blower.

- a. Turn off power to the air cleaner; tip unit upside down and remove bottom plate to access power supply.
 - b. Find the J2 jumper on the power supply, and clip it out. See Fig. 11.
 - c. Replace the air cleaner bottom plate; turn on power.
- Regular replacement of the carbon filter (every 3 to 6 months) will also help reduce ozone odor.

Fig. 10—Use an ohmmeter to check the cell for short circuits as instructed in Fig. 6.

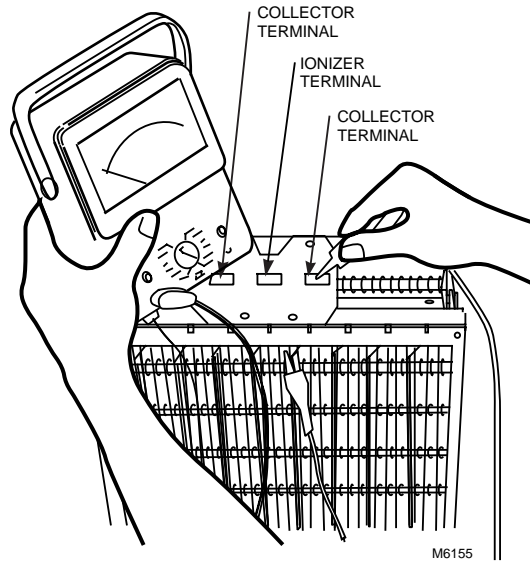
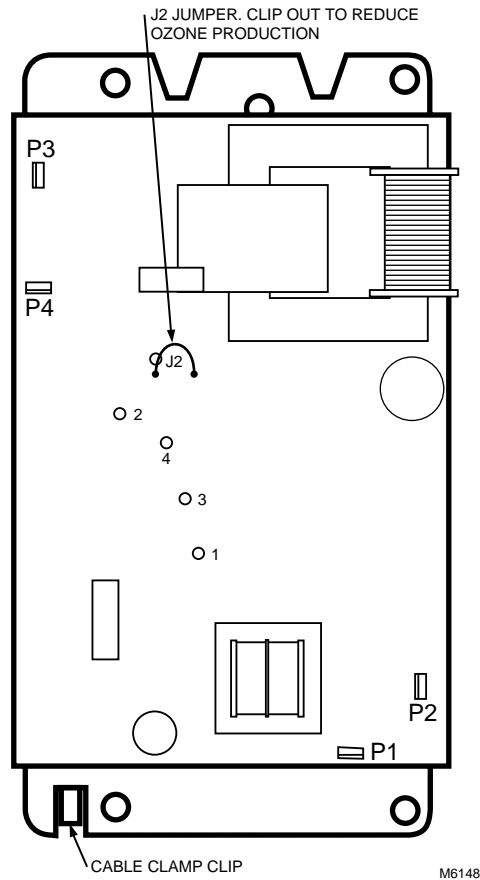

Fig. 11—Clip out the J2 jumper to reduce ozone production about 20 to 25 percent.



Parts List

Number	Description	Part Number	
		120 Vac, 60 Hz	220 Vac, 50 Hz
1	Prefilter	190356	190356
2	Electronic Cell	FC37A1130	FC37A1130
3	Contact Panel	138889A	138889A
4	Solid State Power Supply	203362J	203362W
5	Neon Light	190340	190340
6	Fan Motor	203634	203635
7	Fan Blade	205345	205345
8	Interlock Switch	190070	190070
9	Cell Removal Handle	190358	190358
10	Cell Handle Fastener (2)	190359	190359
11	Cover Latches (male) (2)	190361	190361
12	Cover Latches (female) (2)	190362	190362
13	Mounting Feet (4)	190360	190360
14	Interlock Actuator Bracket	197675	197675
15	Control Switch	190382	196934
16	Carbon Postfilter	203638	203638

Parts and Accessories Not Illustrated

Description	Part Number	
	120 Vac, 60 Hz	220 Vac, 50 Hz
Casters and Hardware	190364A	190364A
Ionizer Wires (multiples of 5)	136434BA	136434BA
Interlock Switch Assembly	4074EBC	4074EBC

Fig. 12—F59A parts are keyed to parts list.

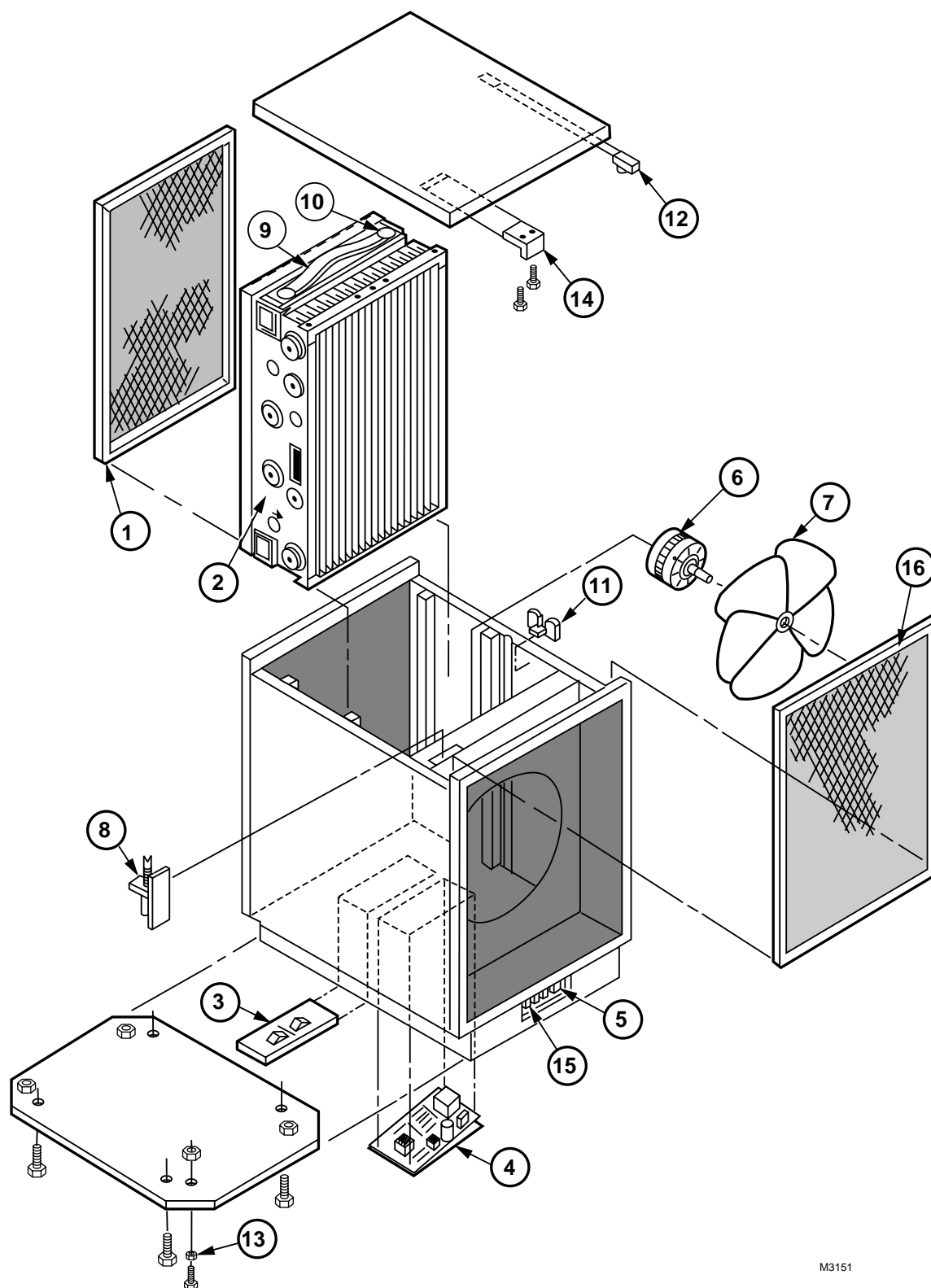

M3151

This equipment is a class B digital apparatus which complies with Canadian Radio Interference Regulations, CRC c. 1374.

Honeywell

Helping You Control Your World

Home and Building Control
Honeywell Inc.
1985 Douglas Drive North
Golden Valley, MN 55422

Home and Building Control
Honeywell Limited—Honeywell Limitée
740 Ellesmere Road
Scarborough, Ontario
M1P 2V9

Printed in U.S.A.

