

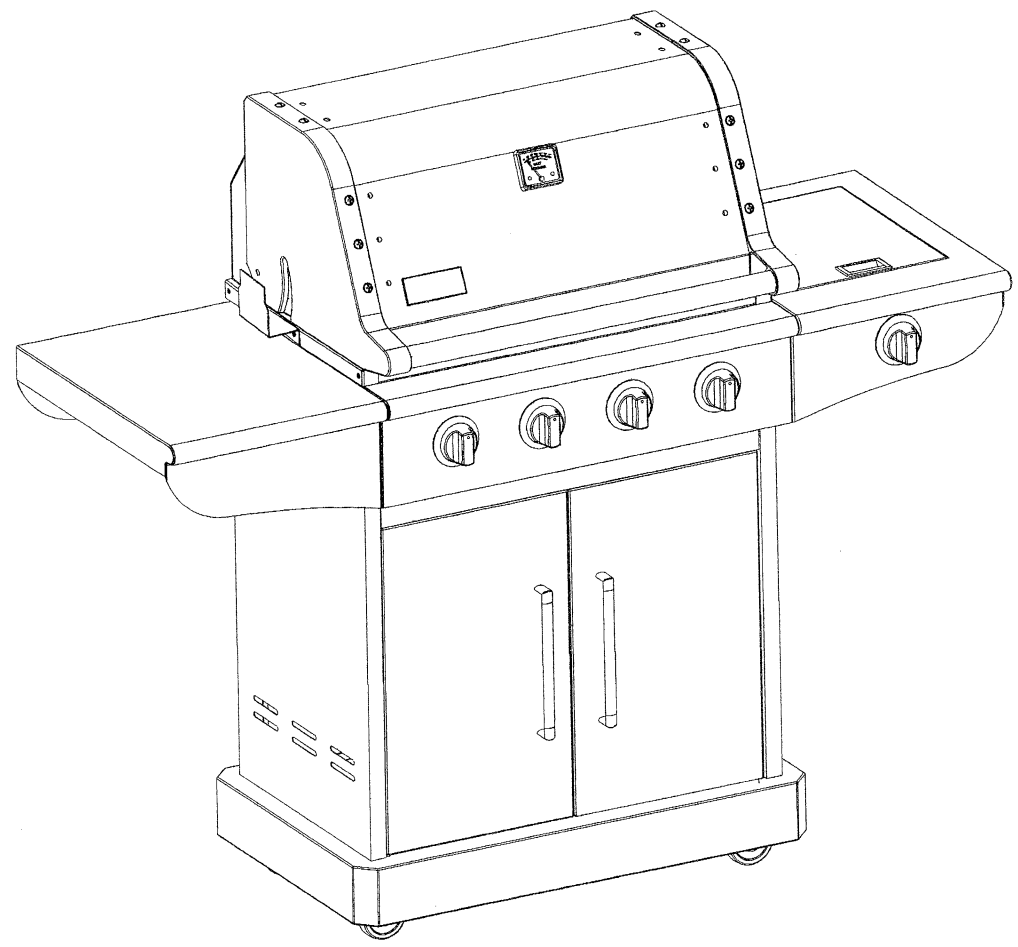

PARTIAL STAINLESS STEEL GAS GRILL ASSEMBLY, USE AND CARE MANUAL

MODEL NO.: PG-40400S



MESSAGE TO OUR USERS

Thank you for selecting our stainless steel gas grill. We hope you will have great enjoyment in using our fine grill.

Do not attempt to assemble and use this grill unless you read this entire manual thoroughly. Keep it in a handy place as it has answers for questions that may occur in your future use.

Any questions please feel free to contact our service center at 1-888-287- 0735, we will be glad to assist you; please refer to this model No. PG-40400S whenever you contact us. Thank you.

VERY IMPORTANT: ANY PROBLEM, PLEASE CONTACT OUR SERVICE CENTER AT 1-888-287-0735; DON'T RETURN TO THE PLACE OF PURCHASE. THANK YOU.

NOTE: THIS APPLIANCE IS NOT INTENDED TO BE INSTALLED IN OR ON RECREATIONAL VEHICLES OR BOATS.

**THIS APPLIANCE IS FOR OUTDOOR USE ONLY
DEAR INSTALLER/ASSEMBLER: PLEASE LEAVE THIS MANUAL TO THE CONSUMER
DEAR CONSUMER: PLEASE KEEP THIS MANUAL FOR FUTURE USE**

!!! WARNING!!!

Failure to follow all manufacturer's instructions could result in serious body injury and/or property damage.

!!! CAUTION!!!

Some parts of this grill may have sharp edges—especially as mentioned in this manual! Wear suitable protective gloves if necessary.

TABLE OF CONTENTS

Importance -----	2	Installer Final Check List-----	10
Installation Safety Precautions -----	3	Grill Lighting Instructions-----	11
Exploded View -----	4	Operation Instructions-----	12
Parts List-----	5	Care & Maintenance-----	13
Assembly Instructions -----	6-7	Trouble Shooting-----	14
Gas Connections-----	8	Grilling Tips-----	15
Leak Testing-----	9	Placement of Grill-----	15-16
		Limited Warranty -----	17

IMPORTANT

Safety Symbols

The symbols and boxes shown below explain what each symbol means.
Read and follow every message found in this manual.

!!! DANGER !!!
DANGER: Indicates an imminently hazardous situation which will result in death or serious body injury if not followed.

!!! WARNING !!!
WARNING: Warn the possibility of serious body injury if the instructions are not followed strictly. Be sure to always read and follow all of the messages.

!!! CAUTION !!!
CAUTION: Indicates a potentially hazardous situation which may result in minor or moderate body injury if not followed.

!!! WARNING!!!
FOR YOUR SAFETY
If you smell gas: 1. Shut off gas to the appliance. 2. Extinguish any open flame. 3. Open lid. 4. If odor continues, immediately call your gas supplier or your fire department.

!!! WARNING!!!
FOR YOUR SAFETY
1. Do not store or use gasoline or other flammable vapors and liquids in the vicinity of this or any other appliance. 2. An LP cylinder not connected for use shall not be stored in the vicinity of this or any other appliance.

INSTALLATION SAFETY PRECAUTIONS

!!! WARNING!!!

Do not try to install this appliance without reading the "INSTALLATION SAFETY PRECAUTIONS" section of this manual.

1. This grill is designed to use LP gas only. So only use grill with LP gas and the regulator assembly supplied by the manufacturer.
2. The installation of this appliance must conform with local codes or, in the absence of local codes, with the **National Fuel Gas Code, ANSI Z223. 1, or CAN/CGA-B149.2 Propane Installation Code.**
3. The LP tank used must conform with the specification for LP-gas cylinders of the **U.S. Department of Transportation (DOT) or the National Standard of Canada, CAN/CSA-B339, Cylinders, Spheres and Tubes for the Transportation of Dangerous Goods.**
4. The motor must be electrically grounded in accordance with local codes or, in the absence of local codes, with **the National Electrical Code, ANSI/NFPA 70-1990, or the Canadian Electrical Code, CSA C22.1.** Keep the power cord of the motor away from the hot surfaces of the grill while in use. Remove and store the motor in a dry place when not in use.
5. This grill is safety certified for use in the United States and Canada only. Never modify to use in other places. Modification may cause serious body injury or property loss.

EXPLODED VIEW

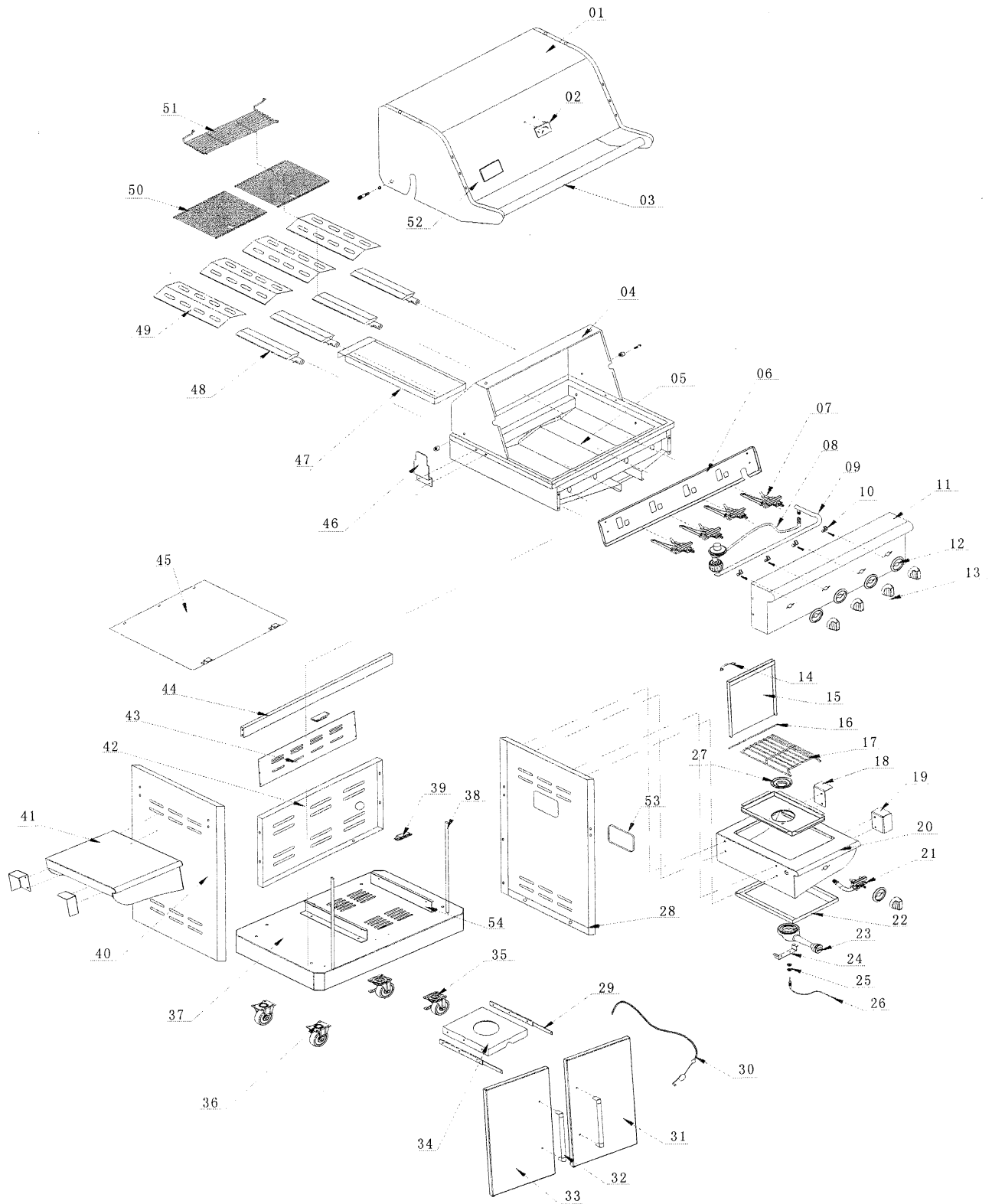

MODEL PG-40400S PARTS LIST

REF#	DESCRIPTION	Q'TY	REF#	DESCRIPTION	Q'TY
1	Double-layer Lid	1	28	Right Panel	1
2	Temp. Gauge	1	29	Gas Tank Tray outer Slides	2
3	Lid Handle	1	30	Lighting Rod	1
4	Firebox Assembly	1	31	Right Door	1
5	V-shape shield	1	32	Door Handles	2
6	Front Baffle	1	33	Left Door	1
7	Valves	3	34	Tank Tray	1
8	Regulator, LP	1	35	Casters with Brakes	2
9	Manifold	1	36	Casters without Brakes	2
10	Manifold Retainer Brackets	4	37	Bottom Panel	1
11	Control Panel	1	38	Door Hinges	2
12	Knob Seats	4	39	Door Magnets	1
13	Control Knobs	4	40	Left Panel	1
14	Handle, Side Burner	1	41	Left Shelf	1
15	Lid, Side Burner	1	42	Back Panel	1
16	Hinge, Side Burner	2	43	Rear Panel	1
17	Cooking Grid, Side Burner	1	44	Door Bracket	1
18	Rib A, Side Burner	2	45	Tank Shield	1
19	Rib B, Side Burner	2	46	Motor Bracket	1
20	Right Shelf Assembly	1	47	Grease Tray	1
21	Gas Valve, Side Burner	1	48	Main Burners	4
22	Side Burner Base	1	49	Flame Tamers	4
23	Side Burner	1	50	Cooking grids with hole	2
24	Bracket A, Side Burner	1	51	Warming Rack	1
25	Ignition Electrode nut	1	52	Name Plate	1
26	Ignition Electrode, Side Burner	1	53	Hole grommet	1
27	Side Burner Brass Ring	1	54	Tank Support Bracket	2

Step II:

1. The two flame tamers, cooking grids and warming rack has been place into the grill head.
2. the warming rack on the warming rack bracket. Your gas grill is ready to use.
- 3.

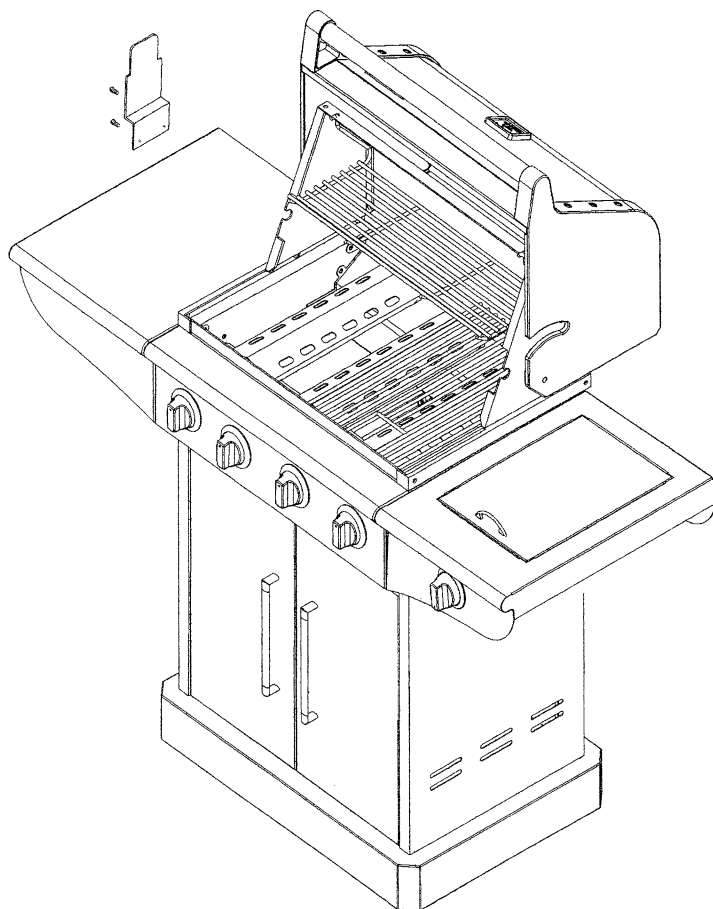

GAS CONNECTION

ONLY USE THE REGULATOR AND HOSE ASSEMBLY PROVIDED WITH THIS GRILL. REPLACEMENT PRESSURE REGULATORS AND HOSE ASSEMBLIES MUST BE THOSE SPECIFIED BY THE MANUFACTURER.

This is a LP (Liquefied Petroleum Gas) configured grill. Do not attempt to use a natural gas supply unless the grill has been reconfigured for natural gas use.

The installation of this appliance must conform with local codes or, in the absence of local codes, with the **National Fuel Gas Code, ANSI Z223. 1, or CAN/CGA-B149.2 Propane Installation Code.**

■ **L.P. Tank Requirements**

the LP tank used with your grill must meet the following requirements:

1. measurement: 12”(30.5cm) (Diameter) X 18” (45.7cm) (Tall)
2. Maximum Capacity: 20lbs. (9Kg)
1. constructed and marked in accordance with the specification for LP-gas cylinders of the **U.S. Department of Transportation (DOT) or the National Standard of Canada, CAN/CSA-B339, Cylinders, Spheres and Tubes for the Transportation of Dangerous Goods.** See LP tank collar for marking.
3. Be arranged for vapor withdrawal.
4. Has a collar to protect the tank valve.
5. No dent or rust. A dented or rusty L.P. tank may be hazardous.

■ **LP tank valve used must meet the following requirements:**

1. Have type I outlet compatible with regulator provided.
2. Have safety relief valve.
3. UL listed Overfill Protection Device (OPD), This OPD safety feature is identified by a unique triangular hand wheel. **Only use tanks equipped with this type of valve. (as the figure shown below)**

For your safety:

Ensure that the black plastic grommets of the regulator provided are in place and that the hose does not come into contact with the heat shield or the grill head.

■ **Connect the regulator to the LP tank:**

VERY IMPORTANT:

- a. **THE REGULATOR SHALL INCORPORATE IN SUCH A LOCATION THAT IT WILL NOT ATTAIN A TEMPERATURE ABOVE 140°F (60°C) .**
- b. **THE REGULATOR SHALL INCORPORATE A PRESSURE RELIEF VALVE OR OVERPRESSURE DEVICE**
- c. **THE INLET OF THE PRESSURE REGULATOR SHALL BE FITTED TO CONNECT THE TYPE I CONNECTION OF THE TANK VALVE PER ANSIZ21.81**

1. Make sure tank valve is in its full off position (turn clockwise to stop)
2. Check tank valve to assure it has proper external male threads (type I connection per ANSIZ21.81)
3. Make sure all burner knobs are in their off position.
4. Remove the protective cap from LP tank valve, Always use cap and strap supplied with valve.
5. Inspect valve connection port and regulator assembly. Look for any damage or debris. Remove any debris. Inspect hose for damage. Never attempt to use damaged or plugged equipment. Contact your local L.P. gas dealer for repair.
6. When connect regulator assembly to the valve, hand tighten nut clockwise to a positive stop. Do not use a wrench to tighten. Use of a wrench may damage quick coupling nut and result in a hazardous condition. (as the figure shown below)

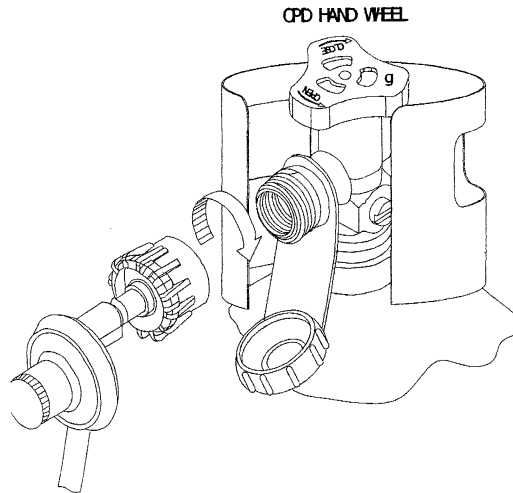

7. Open tank valve fully (counterclockwise). Use a soapy water solution to check all connections for leaks before attempting to light grill. If a leak is found, turn tank valve off and do not use grill until a local L.P. gas dealer can make repairs.

!!! WARNING!!!

1. Never insert any foreign objects into the valve outlet. It may damage the valve and cause leak, leaking gas may result in fire, explosion, heavy body injury, or even death.
2. Do not connect this grill to the self-contained LP gas system of a motor home or camper trailer.
3. Do not use this grill until leak tested.
4. STOP and call the fire department if any leak detected.
5. If you cannot stop a gas leak, close the LP tank valve IMMEDIATELY, call LP gas supplier or the fire department.

!!! DANGER!!!

1. NEVER store a spare LP tank under or near grill or in an enclosed area.
2. NEVER fill the tank beyond 80% full. An overfilled spare LP tank is dangerous because surplus gas may leak from safety relief valve. The safety relief valve on a LP tank could activate to release gas and cause a fire.
3. The spare LP tank must have safety caps installed on the LP tank outlet.
4. If any gas leak found on the spare LP tank, immediately go away from it and call the fire department.

VERY IMPORTANT: DISCONNECTED THE TANK WHEN THIS GRILL IS NOT IN USE.

■ **To disconnect L.P. gas tank:**

1. Turn all the knobs off.
2. Turn the tank valve off fully (turn clockwise to stop).
3. Detach the regulator assembly from tank valve by turning the quick coupling nut counterclockwise.
4. Install the protective cap back LP tank valve.

LEAK TESTING

■ **GENERAL**

Although all gas connections on the grill are leak tested at the factory prior to shipment, a complete gas tightness check must be performed at the installation site due to possible mishandling in shipment, or excessive pressure unknowingly being applied to the unit. Periodically check the whole system for leaks, or immediately check if the smell of gas is detected.

■ **BEFORE TEST**

1. Make sure that all packing material is removed from the grill including the burner tie-down straps.
2. Do not smoke while leak testing.
3. Never leak test with an open flame.
4. Make a soap solution with one part liquid detergent and one part water. Prepare a spray bottle, brush, or rag to apply the solution to the connections. For the initial leak test, make sure the L.P. cylinder is full.
5. Grill must be leak tested outdoors in well-ventilated area, away from ignition sources such as gas fired or electrical appliances, and flammable materials.
6. Keep grill away from open flames and/or sparks while testing.

■ **TO TEST**

1. Make sure all control knobs are in the "OFF" position.
2. Make sure the regulator is connected to the LP tank tightly.
3. Completely open LP tank valve by turning counter clockwise. If you hear a "POP" sound, turn gas off IMMEDIATELY, it indicates a heavy leak at the connection. Call your gas dealer or fire department.
4. Check every connection from the L.P. tank up to and including the connection to the manifold pipe assembly (the pipe that goes to the burner) by brushing or spraying the soapy solution on the connections.
5. If soap bubbles appear, there is a leak. Turn off LP tank valve IMMEDIATELY and retighten connections, Open LP tank valve again, and recheck.
6. If leaks cannot be stopped, **DO NOT ATTEMPT TO REPAIR. Call our service center at 1-888-287-0735 for help.**
7. Always close the LP tank valve after leak test by turning clockwise.

Only those parts recommended by the manufacturer should be used on the grill. Substitution can void the warranty. Do not use the grill until all connections have been checked and do not leak.

■ **SAFETY TIPS**

1. ALWAYS CHECK FOR LEAKS AFTER EVERY L.P. TANK CHANGE
2. ALWAYS CHECK FOR LEAKS OF EVERY CONNECTIONS BEFORE EACH USE.
3. USE LONG BBQ TOOL TO AVOID BURNS.
4. IF ANY GREASE OR HOT ITEMS FALLING FROM THE GRILL ONTO THE VALVE, REGULATOR, HOSE, ANYTHING CONVEYING THE GAS, CLOSE THE GAS IMMEDIATELY. CHECK THE CAUSE, AND REMOVE THE CAUSE. REPERFORM THE LEAK TEST BEFORE CONTINUING.
5. DO NOT REMOVE THE GREASE TRAY IF THE GRILL HASN'T COMPLETELY COOLED.
6. CLOSE ALL CONTROL KNOBS AND LP TANK VALVE WHEN THE GRILL IS NOT IN USE.
7. NEVER MOVE THE GRILL WHILE IN USE OR STILL HOT.
8. PUSH THE GRILL FORWARD, DO NOT PULL WHEN MOVING IT.
9. DISCONNECTED LP TANK IN STORAGE OR BEING TRANSPORTED MUST HAVE A SAFETY CAP INSTALLED. DO NOT STORE AN LP TANK IN ENCLOSED SPACES LIKE CARPORT, COVERED PATIO, PORCH, GARAGE OR OTHER BUILDINGS.
10. NEVER LEAVE A LP TANK IN A RECREATIONAL VEHICLE OR BOAT WHICH MAY BECOME OVERHEATED BY THE SUN.
11. DO NOT STORE LP TANK IN OR NEAR AN AREA WHERE CHILDREN PLAY.
12. DISCONNECTED THE TANK AND REMOVE FROM THE GRILL IF THE GRILL IS STORED INDOORS.
13. ANY OTHER PROBLEM, SEE "TROUBLESHOOTING" OR CONTACT OUR SERVICE CENTER AT 1-888-287-0735.

INSTALLER FINAL CHECK LIST

- At least 21" clearance maintained from combustible constructions to the sides and back of this grill.
- There is no unprotected combustible construction over the grill
- All internal packaging removed.
- Burners are sitting properly on orifices.
- Knobs turn freely.
- The regulator & hose connected to grill is provided by the manufacturer (pre-set for 11.0" water column).

-
- Unit tested and free of leaks.
 - User informed of gas supply shut off valve location.

DEAR CONSUMER, PLEASE KEEP THIS MANUAL FOR FUTURE USE.

GRILL LIGHTING INSTRUCTIONS

■ **WARNING: IMPORTANT!**

■ **BEFORE LIGHTING**

Finally inspect the gas supply hose before turning the gas “ON”. If there is evidence of cuts, wear, or abrasion, it must be replaced before use, the replacement hose assembly shall be that specified by the manufacturer.

VERY IMPORTANT: ALWAYS INSPECT THE HOSE BEFORE EACH USE OF THIS GRILL.

■ **TO LIGHT MAIN AND SIDE BURNERS OF THE GRILL:**

1. Read instructions before lighting.
2. Turn all knobs to “OFF” then open the LP tank valve. Always keep your face and body as far from the grill as possible when lighting
3. Open lid during lighting.
4. Push and turn any control knob slowly to “HI” position. The built-in igniter will click and spark simultaneously to light the pilot and burner in sequence. Turn the control knob to OFF IMMEDIATELY if the burner does not light within 5 seconds, wait 5 minutes for gas to dispel, then repeat the lighting procedure..
5. Follow match lighting instructions if burner can't be lit after repeated 3-4 times.

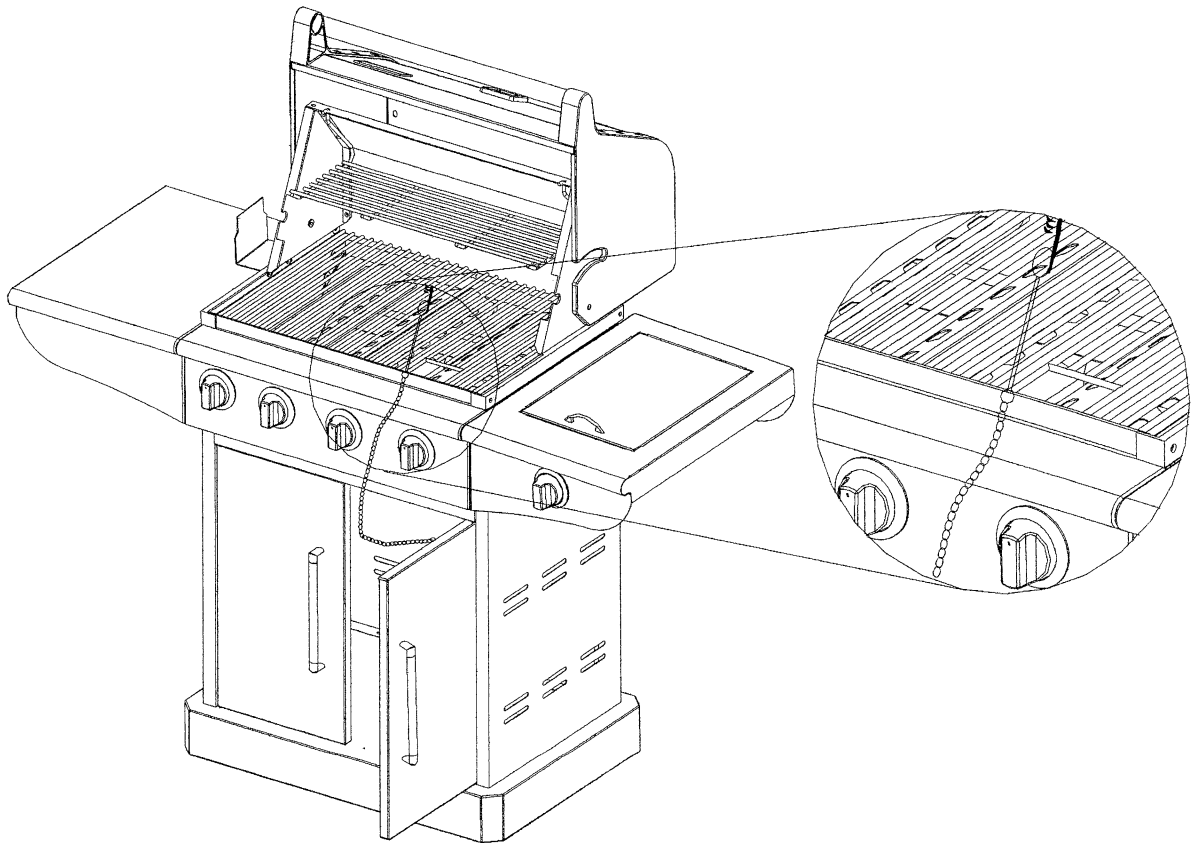

■ **TO LIGHT THE MAIN AND SIDE BURNERS BY MATCH (AS THE ABOVE FIGURE SHOWN):**
If the burner will not light after several attempts then the burner can be match lit.

Tools:

lighting rod (hanging behind the right door)

Usage:

1. Read instructions before lighting.
2. Open the lid during lighting.
3. **Simply place a lighted match between the coils on the end of the lighting rod and hold next to the burner to ignite.**
4. Push and turn the knob to "HI" position, make sure the burner lights and stays lighted.
5. Repeat 3.4 to light other burners.

Keep a spray bottle of soapy water near the gas supply valve and check the connections before each use.

Do not light the grill if odor of gas is present, call our service.

■ **Flame Characteristics**

Check for proper burner flame characteristics. Each burner is adjusted prior to shipment; however, variations in the local gas supply may take subtle necessary adjustments.

Burner flames should be blue and stable with no yellow tips, excessive noise, or lifting. If any of these conditions exist call our customer service line. If the flame is yellow, it indicates insufficient air. If the flame is noisy and tends to lift away from the burner, it indicates too much air.

NOTE: small yellow tips are ok

OPERATION INSTRUCTIONS

!!! CAUTION!!!

1. **Often clean the grill, a grease fire that may damage the grill may occur if the grill has not been cleaned frequently**
2. **NEVER leave the grill unattended while using.**
3. **Do not use water to extinguish the grease fire, it may cause body injury. Turn knobs off and LP tank off in case grease fire occurs**
4. **Grease fire can't be put out by closing the lid. Turn off knobs and LP tank IMMEDIATELY if any grease fire occurs.**

!!! WARNING!!!

For your safety use of grill:

1. **Keep grill area clear and free from any flammable material.**
2. **NEVER let children operate the grill or play near the grill.**
3. **This grill is for outdoor use ONLY. NEVER use in a enclosed area like carport, porch, covered patio, garage, or under a surface that can catch fire.**
4. **Do not block the ventilation holes in the four sides of the grill cart, it may affect the combustion performance of the burner due to insufficient air.**
5. **Use grill at least 21" away from any wall or surface. 120" away from objects that may spark and ignite gas i.e. live electrical appliances, pilot lights of water heaters, etc.**
6. **Do not use this grill on or under wood balconies.**

7. This grill is designed to use only LP gas, DO NOT use lava rock, briquets, charcoal on it.
8. NEVER light the burner with lid closed. Non-ignited gas accumulated inside a closed grill may cause explosions.
9. Check the burner flames periodically.
10. Turn off the gas supply when the grill is not in use.
11. Always turn off the LP tank completely and detach from the grill before moving.

■ **TOTAL GAS CONSUMPTION:**

Total gas consumption (per hour) of PG-40400S grill with all burners on "HI":

Main burners	40,000 Btu/hr
Side burner	12,000 Btu/hr
Total	52,000 Btu/hr

■ **GENERAL USE OF THE GRILL**

The grill burners encompass the entire cooking area and are side ported to minimize blockage from falling grease and debris. Above the burners are stainless steel radiated. The igniter knobs are located on the valve panel. Follow the lighting instructions printed on the control panel.

■ **USING THE GRILL:**

Grilling requires high heat for searing and proper browning. Most foods are cooked at the "HI" heat setting for the entire cooking time. However, when grilling large pieces of meat or poultry, it may be necessary to turn the heat to a lower setting after the initial browning. This cooks the food through without burning the outside. Foods cooked for a long time or basted with a sugary marinade may need a lower heat setting near the end of the cooking time.

Make sure the grill has been leak tested and is properly located.

Remove any packing material.

Light the grill burners using the instructions in this manual.

Turn the control knob to "HI" and preheat the grill for 15 minutes.

Notice: The grill lid is to be closed during the appliance preheat period.

Place the food on the grill and cook to the desired doneness. Adjust heat setting, if necessary. The control knob may be set to any position between "HI" and "LO".

NOTE: The grill is designed to grill efficiently without the use of lava rocks or briquettes of any kind. Heat is radiated by the stainless steel flame tamers under the stainless steel cooking grids.

NOTE: The hot grill sears the food, sealing in the juices. The longer the preheat, the faster the meat browns.

!!! WARNING!!!

Electrical Grounding Instructions

1. This grill is equipped with a three-prong (grounding) plug for your protection against shock hazard and should be plugged directly into a properly grounded three-prong receptacle.
2. Do not cut or remove the grounding prong from this plug.
3. Keep any electrical supply cord and the fuel supply hose away from any heated surfaces. Remove and store the motor in a dry place when not use.

CARE & MAINTENANCE

■ **MAINTENANCE**

1. Keep the grill area clear and free from combustible materials, gasoline and other flammable vapors and liquids.
2. Keep the holes in the three sides of the cart clear and free from debris, thus ensure the flow of combustion

- and ventilation air is unobstructed.
3. Visually check burner flames as following:
 - a. remove cooking grids and flame tamers
 - b. light burners.
 - c. turn knobs from HI to LO, Check the flame status, the flame in LO position should be smaller than in HI position, as figure shown below.
 - d. Always check flame before each use, see TROUBLESHOOTING if any abnormal status found.

HI
—

LO
—



4. Call our after service center at 1-888-287-0735 warranty replacement parts

■ **CLEANING**

■ **STAINLESS STEEL CLEANING**

The grill is made of stainless steel. There are many different stainless steel cleaners available. Always use the mildest cleaning procedure first, scrubbing in the direction of the grain. To touch up noticeable scratches in the stainless steel, sand very lightly with dry 100 grit emery papers in the direction of the grain. Specks of grease can gather on the surfaces of the stainless steel and bake on to the surface and give the appearance of rust. Use an abrasive pad in conjunction with a stainless steel cleaner to remove

DO NOT USE ACID DETERGENT AND/OR ANTIRUST TO CLEAN THE CONTROL PANEL WITH PRINTING. SUCH STRONG CLEANSER MAY CLEAN OFF THE PRINTING.

■ **COOKING AREA CLEANING**

The easiest way to clean the grill is to clean immediately after turning off the flame and cooking is completed. Wear a barbeque mitt to protect your hand from the heat and steam. Dip a brass bristle barbeque brush in tap water and scrub the hot grill. Dip the brush frequently in the water. Steam, created as water contacts the hot grill, assists the cleaning process by softening any food particles. The food particles will fall and burn. Never immerse a hot parts in water.

■ **GRILL BURNER CLEANING**

1. Be sure the tank valve and the knobs are in the "OFF" position. Make sure the grill is cool.
2. Clean the exterior of the burner with a wire brush. Clear stubborn scale with a metal scraper. Clear any clogged ports with a straightened paper clip. Never use a wooden toothpick as it may break off and clog the port.
3. Please note if insects or other obstructions are blocking the flow of gas through the burner, you will need to call our customer service line.

VERY IMPORTANT: The orifice of the valve must be located in the center of burner section after move and clean. Otherwise, it may cause serious body injury and property damage. Swing the burner slightly after replaced to check whether it is installed properly.

The frequency to clean the burner relies on how often you use the grill.

■ **GREASE TRAY CLEANING:**

The grease tray should be emptied and wiped down periodically and washed in a mild detergent and warm water solution. A small amount of sand or cat litter may be placed in bottom of grease tray to absorb the grease.

TROUBLE SHOOTING

■ **SPIDER AND INSECT WARNING!!!**

Spiders and insects can nest in the burners after storing, these nest can cause fires inside the tube or beneath the grill. This is very dangerous condition. So always clean the burners before use after storing.

LIMITED WARRANTY

MODEL NO.: PG-40400S

DESCRIPTION OF GOODS: PARTLY STAINLESS STEEL OUTDOOR GAS GRILL

PerfectGlo, Inc. warrants to the original consumer/purchaser of each Outdoor Gas Grill that when subject to normal residential use, it is free from defects in workmanship and materials for the periods specified below. This warranty excludes grills used in rental or commercial applications. There will be a shipping and handling charge for the delivery of the warranty part(s).

<u>Component</u>	<u>Warranty Period:</u>
Burners:	5 Years
Stainless Steel Flame Tamer:	3 Years
Stainless Steel Cooking Grids:	3 Years
Valves:	1 Year
Frame, Housing, Cart, Control Panel, Igniter, and Related Parts:	1 Year
All Stainless Steel Parts	3 Years

Our obligation under this warranty is limited to repair or replacement, at our option, of the product during the warranty period. The extent of any liability of PerfectGlo Inc. under this warranty is limited to repair or replacement. This warranty does not cover normal wear of parts, damage resulting from any of the following: negligent use or misuse of the product, use on improper fuel/gas supply, use contrary to operating instructions, or alteration by any person other than our factory service center. The warranty period is not extended by such repair or replacement.

Warranty claim procedure: If you require service or parts for your grill, please contact our Warranty Service Center for factory direct assistance. **Our hours of operation are Monday to Friday 8 am to 5 pm PST. Our Tel. number is 1-888-287-0735, our address is: 14125 Telephone Ave, suite #8, Chino, CA91710. ATTN: Warranty Service Center of PerfectGlo, Inc. e-mail >**

Product repair as provided under this warranty is your exclusive remedy. PerfectGlo Inc. shall not be liable for any incidental or consequential damages for breach of any express or implied warranty on its products. Except to the extent prohibited by applicable law, any implied warranty or merchantability or fitness for a particular purpose on this product to the duration of the above warranty. Some states do not allow the exclusion or limitation of incidental or consequential damages, or allow limitations on how long an implied warranty lasts, so the above limitations or exclusions may not apply to you. This warranty gives you specific legal rights, and you may have other rights, which vary from state to state.