

This Owner's Manual is provided and hosted by [Appliance Factory Parts](#).



Members Mark Y0660-1 Owner's Manual

[Shop genuine replacement parts for Members Mark
Y0660-1](#)



Member's Mark®

[Find Your Members Mark Grill Parts - Select From 133 Models](#)

----- Manual continues below -----

Owner's Manual



Liquid Propane Gas Grill

MODEL Y0660

Natural Gas Grill

MODEL Y0660 N.G.

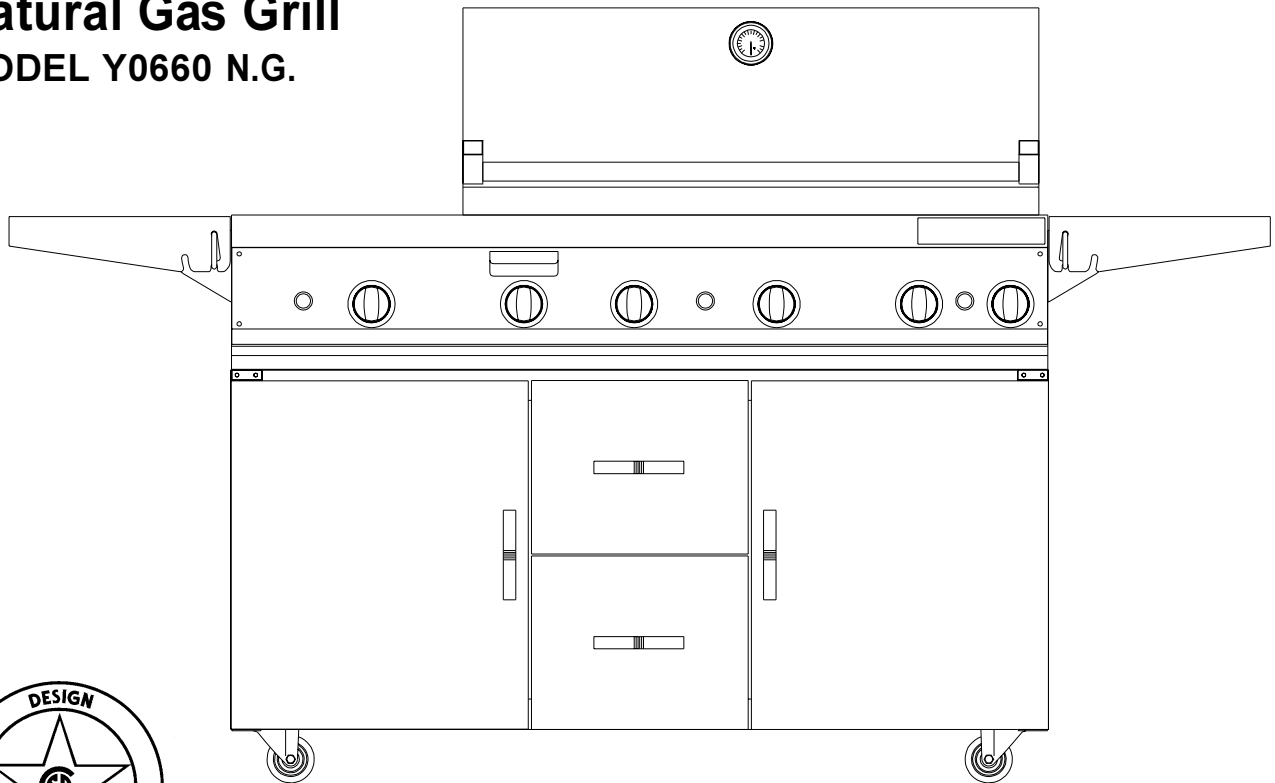

Customer Service Helpline: If you have questions about assembly or grill operation, or if there are damaged or missing parts when you unpack this unit from the shipping box, call us 8:00am - 4:30 pm CST, Monday through Friday at **1-800-770-9769**

WARNING:

Read this Owner's Manual carefully and be sure your gas grill is properly assembled, installed and maintained. Failure to follow these instructions could result in serious bodily injury and/or property damage. This gas grill is intended for outdoor use only and is not intended to be installed in or on recreational vehicles or boats.

Note to Installer: Leave this Owner's Manual with the consumer after delivery and/or installation.

Note to Consumer: Leave this Owner's Manual in a convenient place for future reference.

Manufacturer:

Grand Hall Enterprise Co., Ltd.
9th Fl., No.298, Rueiguang Rd., Neihu,
Taipei, Taiwan (114)

P47B1H - Rev: 04/25/2002

Table of Contents

Warranty	2
Safety Instructions	2-4
Instructions Before Using Your Grill	5
Parts Diagram and Lists	6
Assembly Instructions	8
Lighting Instructions	10
Cleaning and Maintenance Instructions	13
Frequently Asked Questions	15
Cooking Instructions	16
Cooking Guide and Recipes	17

Member's Mark Grill Warranty

Limited Warranty on Selected Grill Parts

Following the time periods designated below, Member's Mark will replace grill parts if they are defective in material or workmanship. You will be charged for shipping and handling charges. This warranty does not cover labor charges.

- Lifetime of Grill: All Stainless Steel exterior parts
- 2 Years: Cast Iron Burners
- 2 Years: All Other Grill Parts (except flame tamers and ignitor battery)

Warranty Service

Warranty service is available by contacting our service center help line at 1-800-770-9769, Monday through Friday, 8:00AM to 4:30PM CST.

Warranty Restrictions

This warranty is void if grill is used for commercial or rental purposes.

This grill is for use with Liquid Propane (LP) to convert this grill to natural gas is dangerous and will void your product warranty.

This warranty applies only when the grill is used in the United States.

This warranty gives you specific legal rights, and you may also have other rights which vary from state to state.

FOR YOUR SAFETY

1. Do not store or use gasoline or other flammable vapors and liquids in the vicinity of this or any other appliance.
2. An LP cylinder not connected for use shall not be stored in the vicinity of this or any other appliance.

FOR YOUR SAFETY

If you smell gas:

1. Shut off gas to the appliance.
2. Extinguish any open flame.
3. Open lid.
4. If odor continues, immediately call your gas supplier or your fire department.

Read These Safety Instructions

WARNING

Combustion byproducts produced when using this product contain chemicals known to the State of California to cause cancer, birth defects, or other reproductive harm.

WARNING

Failure to comply with these instructions could result in a fire or explosion that could cause serious bodily injury, death, or property damage.

WARNING

Your grill will get very hot. Never lean over the cooking area while using your grill. Do not touch cooking surfaces, grill housing, grill lid or any other grill parts while the grill is in operation, or until the grill has cooled down after use.

Failure to comply with these instructions may result in serious bodily injury.

Grill Installation Codes

This gas grill must be installed in accordance with all local codes. In areas without local codes, follow the latest edition of the National Fuel Gas Code ANSI Z223.1. In Canada, installation must conform to standard CAN/CGA 1b149.1 or 1-b149.2 (Installation Code for Gas Burning Appliances and Equipment) and all local codes.

Correct LP Gas Tank Use

LP gas grill models are designed for use with a standard 20 lb. Liquid Propane Gas (LP gas) tank, not included with grill box. **Never** connect your gas grill to an LP gas tank that exceeds this capacity. A tank of approximately 12 inches in diameter by 18-1/2 inches high is the maximum size LP gas tank to use. We recommend buying an "OPD" gas tank which offers an Overfill Prevention Device. This safety feature prevents the tank from being overfilled which can cause malfunction of the LP gas tank, regulator and/or grill.

The LP gas tank must be constructed and marked in accordance with specifications of the U. S. Dept. of Transportation (DOT). In Canada, the LP gas tank must meet the Canadian Transportation and Communications (CTC) specifications. Also be sure to read and follow all LP instructions on the following page.

If the outdoor cooking gas appliance is not in use, the gas must be turned off at the supply cylinder.

- (a) Do not store a spare LP-gas cylinder under or near this appliance;
- (b) Never fill the cylinder beyond 80 percent full; and
- (c) If the information in (a) and (b) is not followed exactly, a fire causing death or serious injury may occur.

1. The LP gas tank has a shutoff valve, terminating in an LP gas supply tank valve outlet, that is compatible with a Type 1 tank connection device. The LP gas tank must also have a safety relief device that has a direct communication with the vapor space of the tank.
2. The tank supply system must be arranged for vapor withdrawal.
3. The LP gas tank used must have a collar to protect the tank valve.

Proper Placement and Clearance of Grill

Never use your gas grill in a garage, porch, shed, breezeway or any other enclosed area. Your gas grill is to be used **outdoors only**, at least 21 inches from the back and side of any combustible surface. Your gas grill should not be placed under any surface that will burn. Do not obstruct the flow of ventilation air around the gas grill housing.

This outdoor gas grill is not intended to be installed in or on recreational vehicles and/or boats.

WARNING

Failure to comply with these instructions could result in a fire or explosion that could cause serious bodily injury, death, or property damage.

- **Never** connect an unregulated LP gas tank to your gas grill. The gas regulator assembly supplied with your gas grill is adjusted to have an outlet pressure of 11" water column (W.C.) for connection to an LP gas tank.
- Only use the regulator and hose assembly supplied with your gas grill. Replacement regulators and hose assemblies must be those specified by manufacture.
- Have your LP gas tank filled by a reputable propane gas dealer and visually inspected and re-qualified at each filling.
- Never fill the gas tank beyond 80% full. Have your propane gas dealer check the release valve after every filling to ensure that it remains free of defects.
- Always keep LP gas tanks in an upright position.
- Do not store (or use) gasoline or other flammable vapors and liquids in the vicinity of this gas grill.
- An LP gas tank that is not connected for use must NOT be stored on bottom shelf or in the vicinity of this or any other gas grill.
- Do not subject the LP gas tank to excessive heat.
- Never store an LP gas tank indoors. If you store your gas grill in the garage or other indoor location, **always** disconnect the LP gas tank first and store it safely **in a well-ventilated area outside** and out of **the** reach of children.
- When your gas grill is not in use the gas must be turned off at the LP gas tank.

- Keep the gas regulator hose away from hot grill surfaces and dripping grease. Avoid unnecessary twisting of hose. Visually inspect the hose and **regulator** prior to each use for cuts, cracks, excessive wear or other damage. If the hose **or regulator** appear damaged do not use the gas grill. **Use a 7/8" open end wrench turning the fitting counter clockwise until loose. Replace as necessary with manufactures hose and regulator replacement part from the parts list.** Call our service center at 1-800-770-9769.
- **Never** light your gas grill with the lid closed or before checking to insure the burner tubes are fully seated over the gas valve orifices. **Never** allow children to operate your grill. Do not allow children to play near your grill.

WARNING

A strong gas smell, or the hissing sound of gas indicates a serious problem with your gas grill or the LP gas tank. Failure to immediately follow the steps listed below could result in a fire or explosion that could cause serious bodily injury, death, or property damage.

- Shut off gas supply to the gas grill.
- Turn the control knobs to OFF position.
- Put out any flame with a fire extinguisher.
- Open grill lid.
- Get away from the LP gas tank.
- Do not try to fix the problem yourself.
- If odor continues or you have a fire you cannot extinguish, call your fire department.

Do not call near the LP gas tank because your telephone is an electrical device and could create a spark resulting in fire and/or explosion.

NOTE: The normal flow of gas through the regulator and hose assembly can create a humming noise. A low volume of noise is perfectly normal and will not interfere with operation of the grill. If humming noise is loud and excessive you may need to purge air from the gas line or reset the regulator excess gas flow device. This purging procedure should be done every time a new LP gas tank is connected to your grill. For help call the Customer Service Helpline for assistance.

**Customer Service Helpline,
8:00am - 4:30pm CST,
Monday through Friday at: 1-800-770-9769**

Natural Gas Safety Instructions

- Your natural gas grill is designed to operate on natural gas only, at a pressure of 7" water column (W.C.) (1/4 psig or 1.75 kpa), regulated at the residential meter. Check with your gas utility company for local gas pressure and with your local municipality for building code requirements. If your residential gas line pressure has not been regulated to 7" W.C., contact your local gas utility company for professional assistance.
- The gas pressure regulator provided with this appliance must be used. This regulator is set for an outlet pressure of 4" W.C.
- It is recommended that a Shutoff Valve be installed at the gas supply source outdoors. Install at a point after the gas pipe exits the outside wall and before the quick-disconnect hose, or install it at the point before the gas line piping enters the ground. See **ILL. 1**.
- Pipe sealing compound or pipe thread tape resistant to the action of natural gas must be used on all male pipe threads when making the connection.
- Disconnect your gas grill from fuel source when the gas supply is being tested at high pressures. This gas grill and its individual shutoff valve must be disconnected from the gas supply pipe system during any pressure testing of that system at pressure in excess of 1/2 psi (3.5kpa).
- Turn off your gas grill when the gas supply is being tested at low pressures. The grill must be isolated from the gas supply pipe system by closing its individual manual shutoff valve during any pressure testing of the gas supply pipe system at pressures equal to or less than 1/2 psi (3.5kpa).

ILL.1 (NATURAL GAS MODEL ONLY)

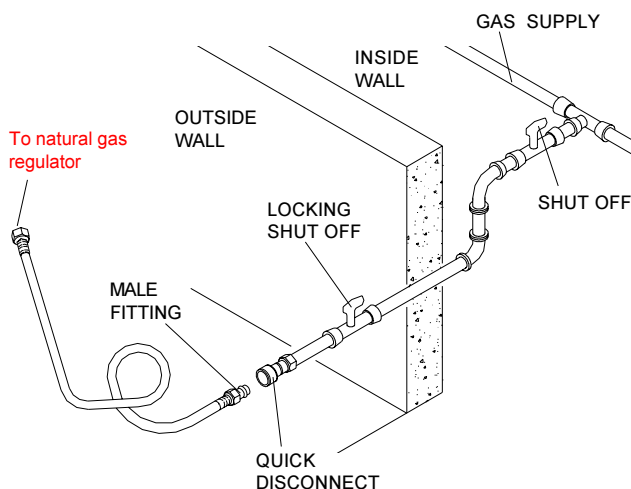

CAUTION: BEWARE OF FLASH-BACK

CAUTION: Spiders and small insects occasionally spin webs or make nests in the grill burner tubes during transit and warehousing. These webs can lead to a gas flow obstruction which could result in a fire in and around the burner tubes. This type of fire is known as a "FLASH-BACK" and can cause serious damage to your grill and create an unsafe operating condition for the user.

Although an obstructed burner tube is not the only cause of "FLASH-BACK", it is the most common cause.

To reduce the chance of "FLASH-BACK", you must clean the burner tubes before assembling your grill, and at least once a month in late summer or early fall when spiders are most active. Also perform this burner tube cleaning procedure if your grill has not been used for an extended period of time.



Before Using Your Grill

To reduce the chance of "FLASH-BACK" (see **CAUTION** at left) clean the burner tubes and burners **before** fully assembling your grill. Remove the cotter pin from the rear underside of each burner using a pair of long nose pliers. Carefully lift each burner up and away from the gas valve orifice, then refer to **ILL. 1** and perform one of these three cleaning methods:

1. Bend a stiff wire, (a lightweight coat hanger works well) into a small hook as shown below. Run the hook through the burner tube and inside the burner several times to remove any debris.
2. Use a bottle brush with a flexible handle. Run the brush through the burner tube and inside the burner several times, removing any debris.
3. Use an air hose to force air through each burner tube. The forced air should pass debris or obstructions through the burner and out the ports.



WARNING

The location of the burner tube with respect to the orifice is vital for safe operation. Check to ensure the orifice is inside of the burner tube before using your gas grill. See **ILL. 2**. If the burner tube does not fit over the valve orifice, lighting the burner may cause explosion and/or fire.

ILL. 2

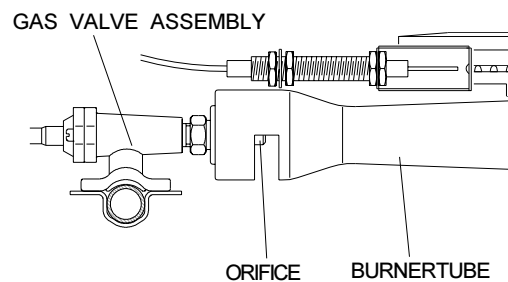

ILL. 1

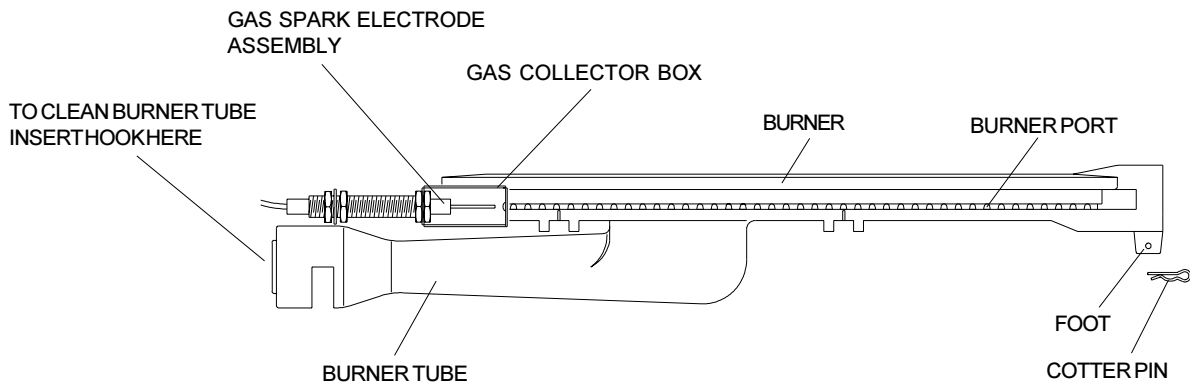

Y0660 Parts Diagram

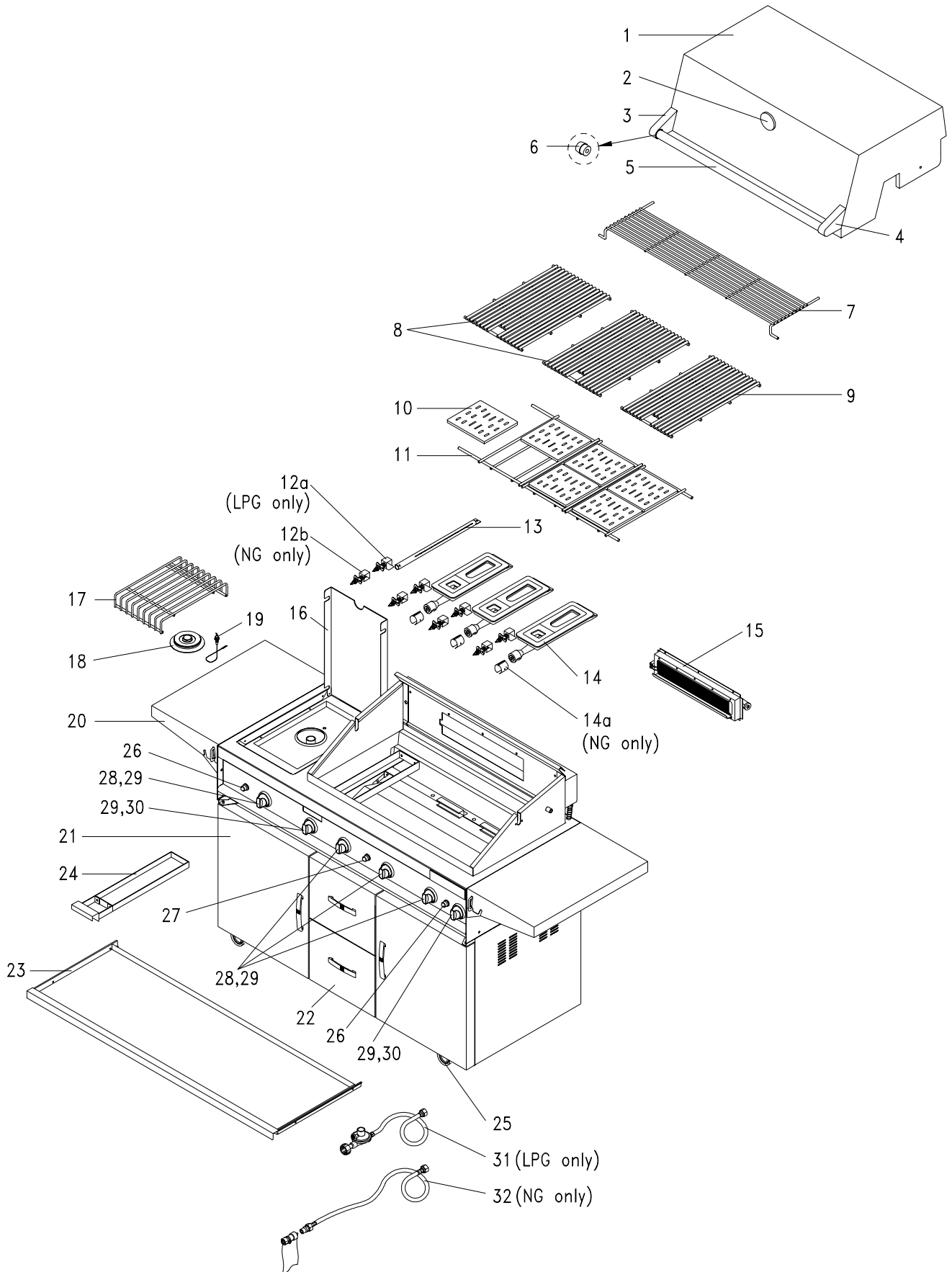

Y0660 Parts List

REF#	DESCRIPTION	PART#	QTY	REF#	DESCRIPTION	PART#	QTY
1	LID ASSEMBLY	P0175A	1	30	CONTROL KNOB	P3431B	2
2	HEAT INDICATOR	P0619A	1	31	REGULATOR AND HOSE (LPG only)	P3632K	1
3	LEFT HANDLE BRACKET	P0312A	1	32	NG 12' HOSE KIT (NG only)	P3723A	1
4	RIGHT HANDLE BRACKET	P0313A	1		NOT SHOWING DIAGRAM		
5	LID HANDLE	P0253A	1	--	HANDLE FOR TANK DRAWER	P0255A	1
6	HEAT-INSULATING INSERT	P5573A	2	--	SPICE BASKET	P5214B	1
7	S/S UPPER WARMING RACK	P1526A	1	--	TOWEL RACK	P80C1A	1
8	S/S COOKING GRID - Large	P1651A	2	--	N. G. REGULATOR KIT	P3648A	1
9	S/S COOKING GRID - Middle	P1652A	1				
10	CERAMIC FLAME TAMER	P1736A	6				
11	WIRE RACK FOR CERAMIC FLAME TAMER	P1739A	1				
12a	GAS COLLECTOR BOX (LPG only)	P2623D	4				
12b	GAS COLLECTOR BOX (NG only)	P2652A	4				
13	SMOKER BURNER	P2053A	1				
14	CAST IRON BURNER - Porcelain	P1925C	3				
14a	AIR SHUTTER (NG only)	P80R7A	3				
15	ROTISSERIE BURNER ROTISSERIE BURNER (LPG only) ROTISSERIE BURNER (NG only)	P1957A P1957B	1				
16	SIDE BURNER LID	P1152A	1				
17	S/S POT SUPPORT	P80H2A	1				
18	BRASS CAP KIT FOR SIDE BURNER	P1951B	1				
19	ELECTRODE	P2641A	1				
20	SIDE SHELF	P1153A	2				
21	FRONT PANEL FOR DOOR	P4344A	2				
22	FRONT PANEL FOR DRAWER	P80H4A	2				
23	GREASE TRAY KIT	P2754A	1				
24	SMOKER DRAWER	P80G9A	1				
25	CASTER	P5117A	4				
26	ELECTRONIC IGNITOR	P2503D	2				
27	ELECTRONIC IGNITOR	P2503C	1				
28	CONTROL KNOB	P3431A	4				
29	KNOB SEAT	P3432A	6				

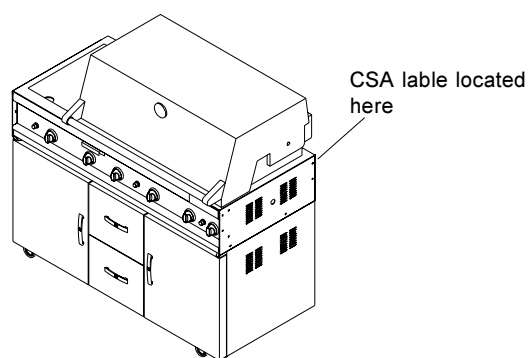

For the repair or replacement parts you need:
Call 8:00am - 4:30 pm CST, Monday through
Friday at 1-800-770-9769

To make sure you obtain the correct replacement
part(s) for your Member's Mark Gas Grill, please
refer to the parts list on this page. The following
information is required to assure getting the
correct part:

1. Gas Model Number (see CSA label on grill)
2. Part Number
3. Description
4. Quantity of parts needed

Please allow sufficient time to process and ship.

IMPORTANT: Keep this Owner's Manual for
convenient referral and for part replacement.

IMPORTANT: Use only factory authorized parts.
The use of any part that is not factory authorized
can be dangerous. This will also void your
warranty.

Customer Service Helpline: If you have questions about assembly or grill operation, or
if there are damaged or missing parts when you unpack this unit from the shipping box, call us
8 : 00 am - 4 : 30 pm CST, Monday through Friday at: **1-800-770-9769**

Assembly Instructions

1. Unscrew each Ignitor Cap located on the grill Control Panel and remove the Contacts and Springs from the Ignitor Slots.
2. Place a manufacturer supplied AA battery into each Ignitor Slot. Be sure to place the positive pole facing toward you. **See ILL. 3.**
3. Place the Spring over the AA battery, then place the Contact on top of the Spring. Screw each Ignitor Cap back onto the grill Control Panel.

ILL. 3

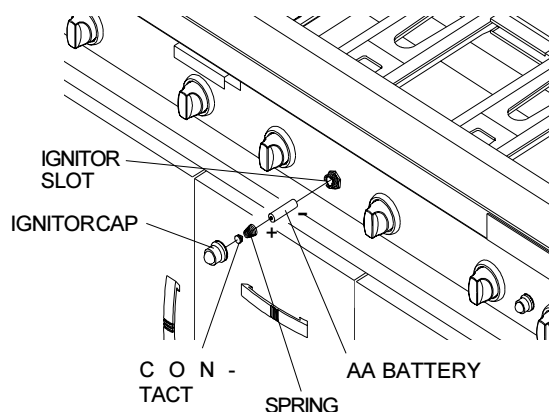

Electrode Check - Requires an Assistant

Before placing the cooking components into your grill, ensure that the Spark Electrode Tip is properly positioned within each Gas Collector Box (a 3-1/4" wide stainless mechanism found at the front between each set of burners.) The easiest way to ensure this is to perform this Electrode Check:

1. Be sure all Control Knobs are set to "OFF". Open the Grill Lid.
2. Have an assistant stand behind to the right of the grill and look down at the Gas Collector Box of the main burners. NEVER put your face inside Grill Head.
3. Press center Ignitor Cap and have assistant watch for a small blue spark within each Gas Collector Box. If a spark is present the Electrode Tips are properly positioned.
4. If no spark is seen the Spark Gap shown in **ILL. 4** needs to be adjusted as follows:
 - Using an adjustable wrench, loosen the Inside Nut just until the Gas Collector Box can be maneuvered and turned upward.
 - The gap between the Spark Electrode Tip and Spark receiver should be approximately 3/16".

- If the gap is wider than 3/16" use a pair of long nose pliers and gently squeeze the Gas Collector Box until the gap is correct.
- Return the Gas Collector Box to its original horizontal position, secure the Inside Nut and try the Electrode Check again.

ILL. 4 - Side View

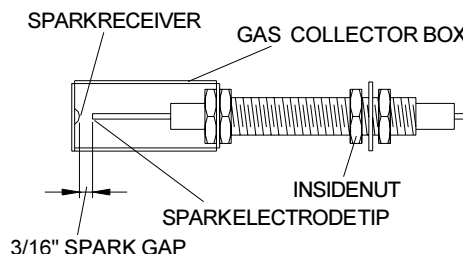

Installing Cooking Components

Important: Before cooking on your grill the first time, wash the cooking grids and warming rack with warm, soapy water. Rinse and dry thoroughly. Season with cooking oil regularly. After cooking is completed, turn grill to HIGH setting for about five minutes to burn off excess grease or food residue.

1. Place the Ceramic Flame Tamers on the Ceramic Rack and place on the lower ledge above the burners. **See ILL. 5.**
2. Evenly space the Stainless Steel Cooking Grids on the ledge above the Flame Tamers.
3. Place the Upper Warming Rack into the holes on the upper left and upper right of the back burner frame with the bottom resting in the slots on either side of the grill bowl.

ILL. 5

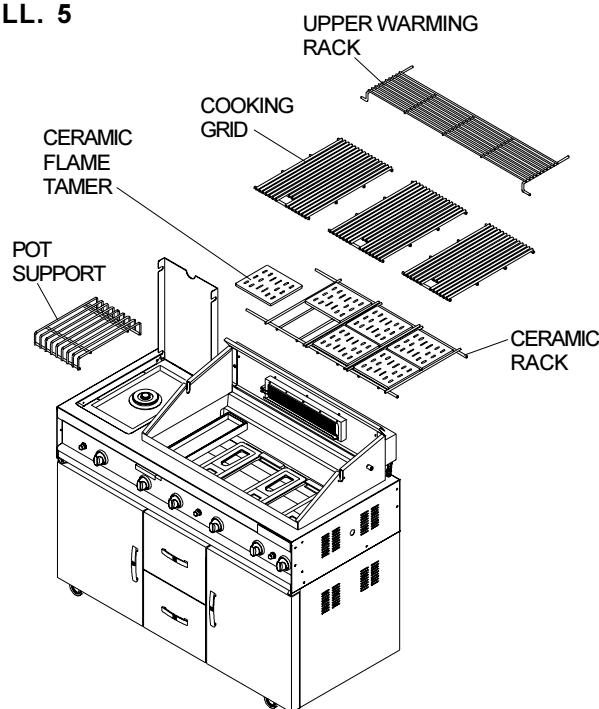

Connecting A Liquid Propane Gas (LP gas) Tank To Your Grill

1. Open the left door. Pull out the LPG tank drawer. Place the 20 lb cylinder with foot ring into the hole in the drawer. See **ILL.6a**. Make sure the tank valve is in the OFF position.

Make sure the gas tank is in right position. Use the 5/16"x90mm wing bolt provided to secure gas tank.

2. Check the tank valve to ensure it has proper external mating threads to fit the hose & regulator assembly provided. See **ILL.6b**. (Type 1 connection per ANSI Z21.58a-1998)
3. Make sure all burner valves are in the OFF position.
4. Inspect the valve connection port and regulator assembly. Look for damage or debris. Remove any debris. Inspect hose for damage. Never use damaged or plugged equipment.
5. When connecting the hose and regulator assembly to the tank valve, hand tighten nut clockwise to a full stop. Do Not use a wrench to tighten because it could damage the Quick Coupling Nut and result in a hazardous condition.
6. Open the tank valve fully (counterclockwise). Use a soapy water solution to check all connections for leaks before attempting to light your grill. See "Checking for LP Gas Leaks" on page 10. If a leak is found, turn the tank valve off and do not use your grill until the leak is repaired.

Disconnecting A Liquid Propane Gas (LP gas) Tank From Your Grill.

1. Turn the burner valves and LP gas tank valve to the full OFF position. (Turn clockwise to close.)
2. Detach the hose and regulator assembly from the LP gas tank valve by turning the Quick Coupling Nut counterclockwise.

Connecting Natural Gas To Your Grill

1. **For Natural Gas grills:** Connect the hose end of the 12' Natural Gas Hose to the **N.G. regulator** kit as shown in **ILL. 6c**. Through the 12' Natural Gas Hose to the hole of Rear Panel to outside. Also read the natural gas safety instructions.

Congratulations

Your Member's Mark gas grill is now ready for use. Before the first use and at the beginning of each season (and whenever the LP gas tank has been changed):

1. Read all safety, lighting and operating instructions.
2. Check gas valve orifices, burner tubes and burner ports for any obstructions.
3. Perform gas leak check according to instructions found on page 10 of this manual.

ILL. 6a (LP gas model only)

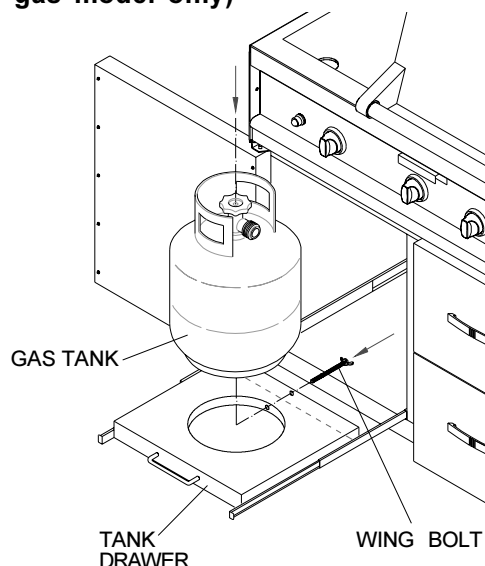

ILL. 6b (LP gas model only)

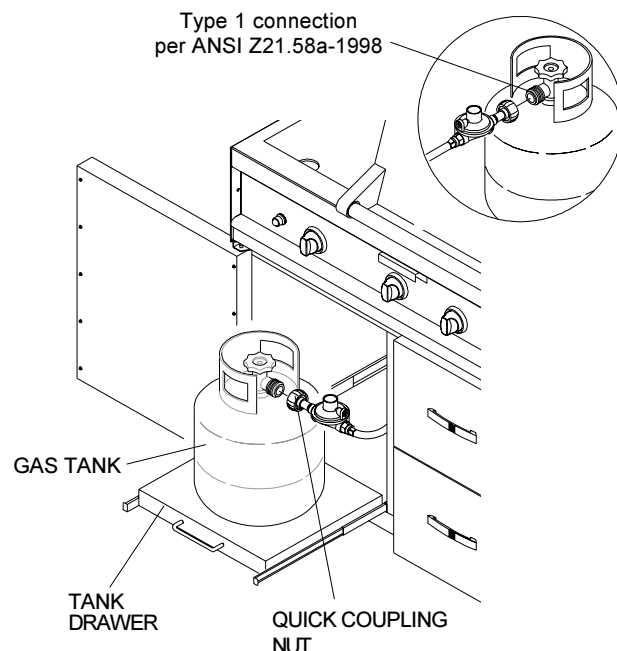

CAUTION: When the appliance is not in use, the gas must be turned off at the supply tank.

ILL. 6c (NATURAL GAS MODEL ONLY)

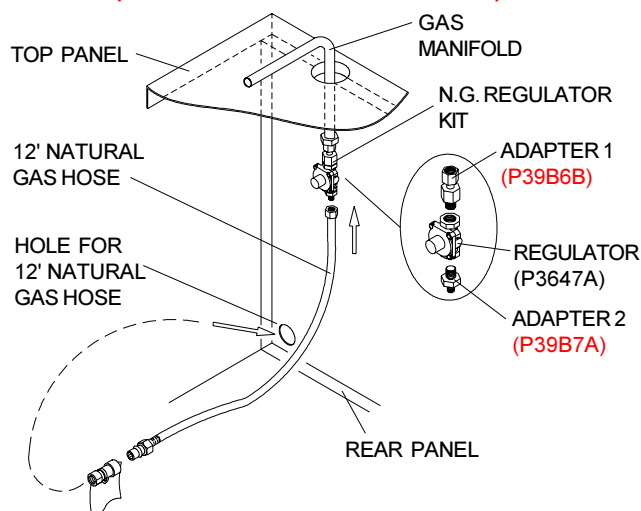

WARNING

A strong gas smell, or the hissing sound of gas indicates a serious problem with your gas grill or the LP gas tank. Failure to immediately follow the steps listed below could result in a fire or explosion that could cause serious bodily injury, death, or property damage.

- Shut off gas supply to the gas grill.
- Turn the control knobs to OFF position.
- Put out any flame with a fire extinguisher.
- Open grill lid.
- Get away from the LP gas tank.
- Do not try to fix the problem yourself.
- If odor continues or you have a fire you cannot extinguish, call your fire department. Do not call near the LP gas tank because

your telephone is an electrical device and could create a spark resulting in fire and/or explosion.

NOTE: The normal flow of gas through the regulator and hose assembly can create a humming noise. A low volume of noise is perfectly normal and will not interfere with operation of the grill. If humming noise is loud and excessive you may need to purge air from the gas line or reset the regulator excess gas flow device. This purging procedure should be done every time a new LP gas tank is connected to your grill. For help call the Customer Service Helpline for assistance.

**Customer Service Helpline,
8am - 4:30 pm CST,
Monday through Friday at 1-800-770-9769.**

Checking For LP Gas Leaks

Never test for leaks with a flame. Prior to first use, at the beginning of each season, or every time your LP gas tank is changed, you must check for gas leaks. Follow these four steps:

1. Make a soap solution by mixing one part liquid detergent and one part water.
2. Turn the grill control knobs to the full OFF position, then turn the gas ON at source.
3. Apply the soap solution to all gas connections. If bubbles appear in the soap solution the connections are not properly sealed. Check each fitting and tighten or repair as necessary.
4. If you have a gas leak that you cannot repair, turn off the gas at the source, disconnect fuel line from your grill and call 1-800-770-9769 or your gas supplier for repair assistance.

Grill Lighting Instructions

Basic Lighting Procedures

1. Familiarize yourself with the safety guidelines at the front of this manual. Do not smoke while lighting grill or checking gas supply connections.
2. Be sure the LP gas tank is filled.
3. Check that the end of each burner tube is properly located over each valve orifice.
4. Make sure all gas connections are securely tightened.
5. Open the Grill Lid or Side Burner Lid, depending on the burner you are lighting.

WARNING

Failure to open Grill Lid during the lighting procedures could result in a fire or explosion that could cause serious bodily injury, death, or property damage.

6. Set control knobs to OFF and open the LP gas tank valve slowly until 1/4 to 1/2 open.

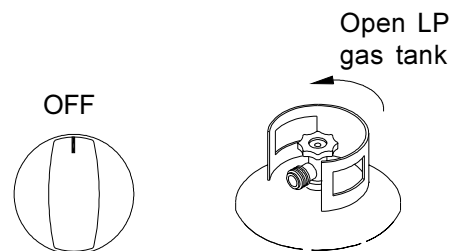

7. Push and turn any control knob for Main Burner to HIGH.

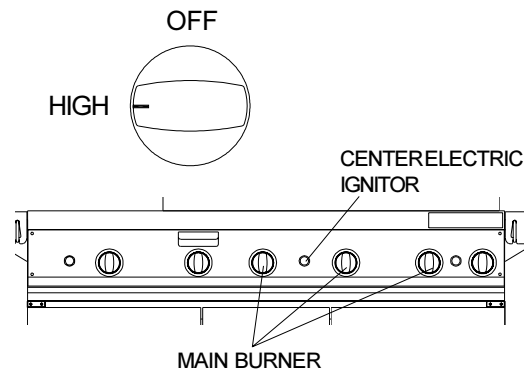

8. Immediately press the center electric ignitor for 3-4 seconds to light the burner.

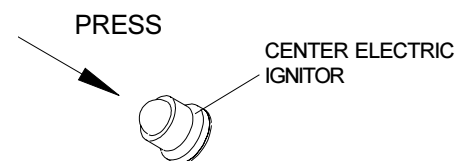

9. If the burner does not light, turn the control knob to OFF, wait 5 minutes for gas to clear, then retry.

- Once the grill burner is ignited, the adjacent burner can be lit by simply turning its control knob to HIGH.
- Adjust control knobs to your desired cooking temperature.

Smoker Burner Lighting Instructions

- Follow steps 1 through 6 of the Basic Lighting Procedures.
- Push and turn the control knob for Smoker Burner to ON.

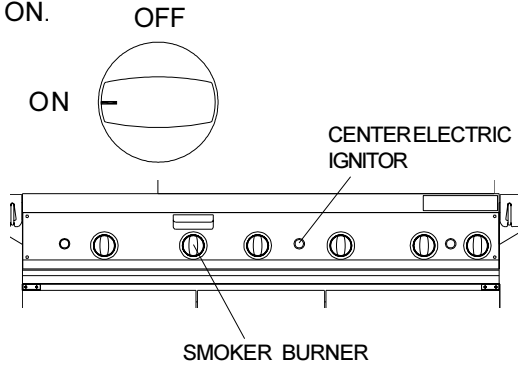

- Immediately press the center electric ignitor for 3-4 seconds to light the burner.
- If the burner does not light, turn the control knob to OFF, wait 5 minutes for gas to clear, then retry.

Side Burner Lighting Instructions

- Follow steps 1 through 6 of the Basic Lighting Procedures.
- Push and turn the control knob for Side Burner to HIGH.

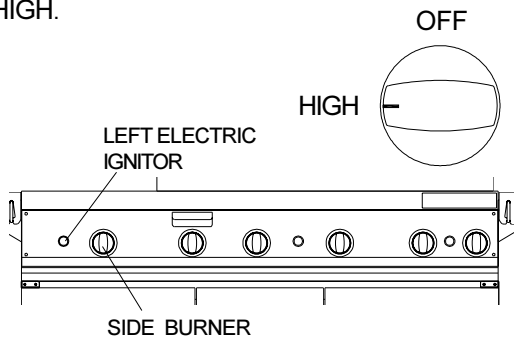

- Immediately press the left electric ignitor for 3-4 seconds to light the burner.

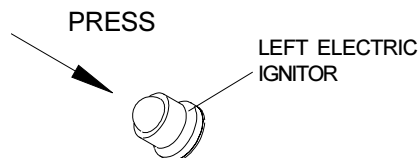

- If the burner does not light, turn the control knob to OFF, wait 5 minutes for gas to clear, then retry.
- Adjust control knobs to your desired cooking temperature.

Rotisserie Burner Lighting Instructions

Note: The location of the Rotisserie burner makes it more susceptible to winds that will decrease the performance of your rotisserie cooking. For this reason you should not operate the back burner during windy weather conditions.

- Follow steps 1 through 4 of the Basic Lighting Procedures.

⚠ WARNING

Failure to open Grill Lid during the lighting procedures could result in a fire or explosion that could cause serious bodily injury, death, or property damage.

- Open the Grill Lid. Failure to do so can result in fire or explosion. See WARNING above.
- Set Rotisserie Burner control knob (knob on right side of Control Panel) to OFF and open the LP gas tank valve.

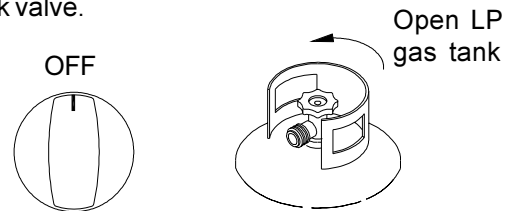

- Push and turn the control knob for Rotisserie Burner to ON.

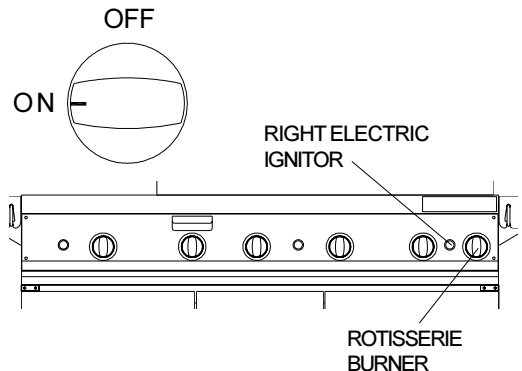

- Then immediately press the right electric ignitor for 3-4 seconds to light the Rotisserie Burner.

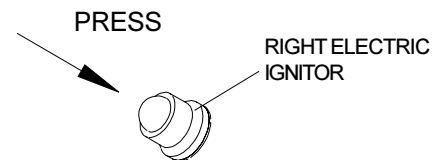

- If the burner does not light, turn the control knob to OFF, wait 5 minutes for gas to clear, then retry.
- Once lit, the Rotisserie Burner will reach cooking temperature quickly. The orange/red glow will even out in about 5 minutes.
- For best results, always rotisserie cook with the grill lid down and the Rotisserie Burner control knob set to ON. Do not use the main grill burners when the Rotisserie Burner is in operation.

Manually Lighting Your Grill by Match

To light your gas grill by match, insert a match into the Manual Lighting Stick and follow steps 1 through 6 of the Basic Lighting Procedures. Then, light the match and place Manual Lighting Stick through the lighting hole on the right side of the grill. See **ILL. 7**. Turn the right main burner control knob to the HIGH setting to release gas. The burner should light immediately. Occasionally observe the burner flame for correct operation. See **ILL. 7**.

ILL. 7

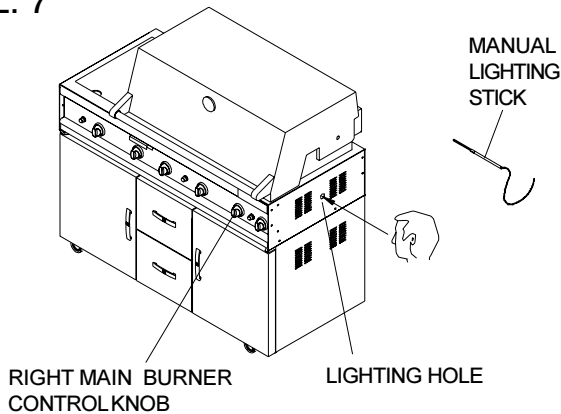

⚠ WARNING

Never lean over the grill cooking area while lighting your gas grill. Keep your face and body a safe distance (at least 18 inches) from the lighting hole or burners, when

If the grill fails to light properly:

1. Turn gas off at source and turn the control knob to OFF. Wait at least five minutes for gas to clear, then retry.
2. Check gas supply and connections.
3. Repeat lighting procedure. If your grill still fails to operate properly, turn the gas off at source, turn the control knobs to OFF, then check the following:
 - Misalignment of burner tubes over orifices
Correction: Reposition burner tubes over orifices.
 - Obstruction in gas line
Correction: Remove fuel line from grill. Do not smoke! Open gas supply for one second to clear any obstruction from fuel line. Close off gas supply at source and reconnect fuel line to grill.
 - Plugged orifice
Correction: Remove burners from grill by pulling cotter pin (beneath burner) using a screwdriver or pliers. Carefully lift each burner up and away from gas valve orifice. Remove the orifice from gas valve and gently clear any obstruction with a fine wire. Then reinstall all orifices, burners, cotter pins and cooking components.

If an obstruction is suspected in gas valves or gas valve bracket, please call the Members Mark service center or your local propane dealer for assistance.

- Misalignment of ignitor on burner
Correction: Check for proper position of the electrode tip as shown in **ILL. 4**. The gap between the Spark Electrode Tip and Spark Receiver should be approximately 3/16". Adjust if necessary. With the gas supply closed and all control knobs set to OFF press the electric ignitor cap and check for the presence of a spark at the electrode.
 - Disconnected Ignition Wires
Correction: Inspect the Ignitor junction box found behind the Control Panel. Connect loose Ignitor wires to junction box and try to light the grill.
 - Weak AA battery
Correction: Unscrew the Ignitor Cap and replace the battery.
4. If the grill still does not light you may need to purge air from the gas line or reset the regulator excess gas flow device. **Note:** This procedure should be done every time a new LP gas tank is connected to your grill.

To purge air from your gas line and/or reset the regulator excess gas flow device:

- Turn the control knobs to the OFF position.
 - Turn off the gas at the tank valve.
 - Disconnect regulator from LP gas tank.
 - Let unit stand for 5 minutes.
 - Reconnect regulator to the LP gas tank.
 - Turn the tank valve on slowly until 1/4 to 1/2 open.
 - Open the Grill Lid.
 - Set control knobs to OFF and open the LP gas tank valve.
 - Push and turn the LEFT control knob to HIGH.
5. If all checks or corrections have been made and you still have questions about operating your gas grill, call the Customer Service Helpline 8am - 4:30pm CST, Monday through Friday at 1-800-770-9769.

⚠ WARNING

Should a "FLASH-BACK" fire occur in/or around the burner tubes, follow the instructions below. Failure to comply with these instructions could result in a fire or explosion that could cause serious bodily injury, death, or property damage.

- Shut off gas supply to the gas grill.
- Turn the control knobs to OFF position.
- Put out any flame with a fire extinguisher.
- Open grill lid.
- Once the grill has cooled down, clean the burner tubes and burners according to the cleaning instructions found on page 14 in this manual.

Cleaning and Maintenance

Keeping the ventilation opening(s) of the cylinder enclosure free and clear from debris.

As with all appliances, proper care and maintenance will keep your grill in top operating condition and prolong its life. By following these cleaning and maintenance procedures on a timely basis, your grill will stay clean and work properly with minimum effort.

NOTE: Make sure you keep your gas grill area clear and free from combustible materials, gasoline and other flammable vapors and liquids. If your grill has a tank enclosure make sure that the ventilating openings are free and clear from debris. Also do not obstruct the flow of air for combustion and ventilation of the grill.

CAUTION:

Be sure your grill is OFF and cool before cleaning.

Cleaning The Cooking Grids

Before initial use and periodically we suggest you wash your cooking grids in a mild soap and warm water solution. You can use a wash cloth or vegetable brush to clean your cooking grids.

Cleaning The Flame Tamers

Periodically you should wash the Flame Tamers in a soap and warm water solution. Use a vegetable brush to remove stubborn burnt-on cooking residue.

Cleaning The Grease Tray

To reduce the chance of fire, the Grease Draining Tray should be visually inspected before each grill use.

Annual Cleaning of The Grill Interior

Burning-off the grill after every cookout will keep it ready for instant use. However, once a year you should give the entire grill a thorough cleaning to keep it in top operating condition. Follow these steps:

1. Turn all burner valves to the full OFF position.
2. Turn the LP gas tank valve to the full OFF position.
3. Detach the LP gas regulator assembly from your gas grill.
4. Remove and clean the flame tamers, cooking grids and grill burners.
5. Cover each gas valve orifice with aluminum foil.
6. Brush the inside and bottom of the grill with a stiff brass wire brush, and wash with a mild soap and warm water solution. Rinse thoroughly and let dry.

Customer Service Helpline: If you have questions about assembly or grill operation, or if there are damaged or missing parts when you unpack this unit from the shipping box, call us 8 : 00 am - 4 : 30 pm CST, Monday through Friday at: **1-800-770-9769**

7. Remove aluminum foil from orifices and check each orifice for obstruction.
8. Check each spark electrode, adjusting as needed. The space between the Spark Electrode Tip and Spark Receiver should be approximately 3/16".
9. Replace the burners and adjust the gas collector box. The edge of the collector box should be overlapping the burner port.
10. Replace flame tamers and the cooking grids.
11. Reconnect the gas source and observe the burner flame for correct operation.

Exterior Stainless Steel Surfaces:

Daily weathering and high heat associated with grill cooking can cause exterior stainless surfaces to "tan". Follow these directions for best results, and NEVER clean a hot grill.

1. Shut off gas supply at source and disconnect fuel line from gas valve manifold. Protect fuel line fitting.
2. Remove dirt or grease using a soft cloth, then polish stainless surfaces with a Foam Spray cleaner designed for stainless steel. Never use an abrasive cleaner or scrubber that may scratch your stainless surfaces.
3. Dry with a soft cloth and let air dry before restarting grill.

VISUALLY CHECKING BURNER FLAMES

Occasionally observe burner flame for correct operation. See ILL 8.

ILL. 8

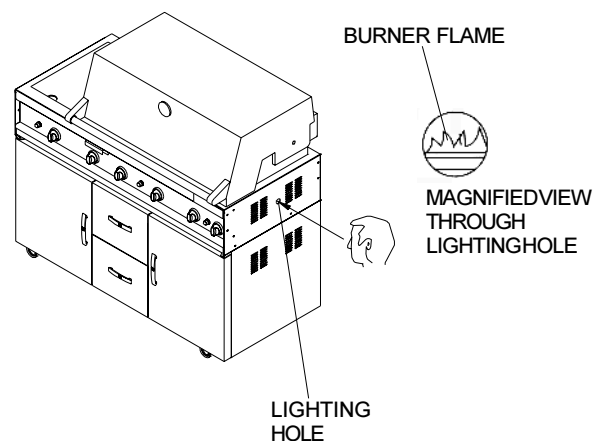

Cleaning The Burner Tubes and Burner Ports

To reduce the chance of "FLASH-BACK" the procedure below should be followed at least once a month in late summer or early fall when spiders are most active or when your grill has not been used for a period of time.

1. Turn all burner valves to the full OFF position.
2. Turn the LP gas tank valve to the full OFF position.
3. Detach the LP gas regulator assembly from your gas grill.
4. Remove the cooking grids, flame tamers, and grease trays from your grill.
5. Remove the cotter pin from the rear underside of each burner using a pair of long nose pliers.
6. Carefully lift each burner up and away from the gas valve orifice.
7. Refer to **ILL. 1** and perform one of these three cleaning methods:

- Bend a stiff wire, (a lightweight coat hanger works well) into a small hook as shown below. Run the hook through the burner tube and inside the burner several times to remove any debris.



- Use a bottle brush with a flexible handle. Run the brush through the burner tube and inside the burner several times, removing any debris.
- Use an air hose to force air through each burner tube. The forced air should pass debris or obstructions through the burner and out the ports.

ILL. 1

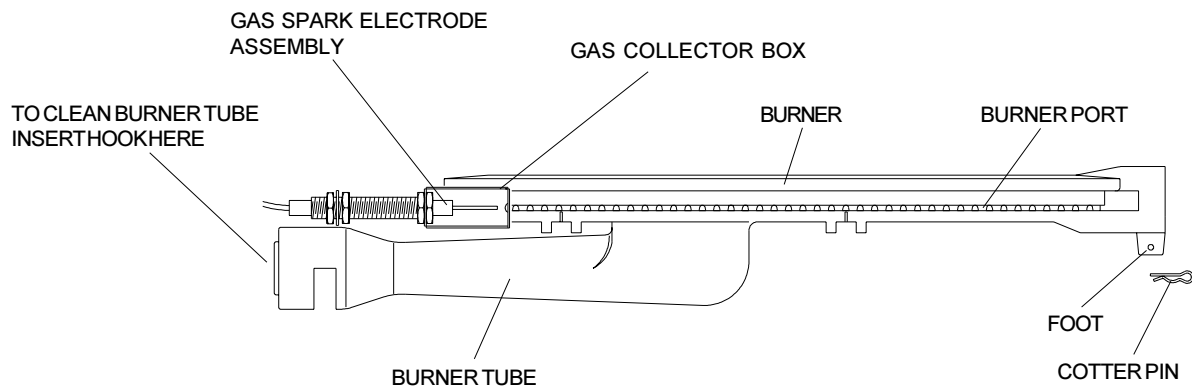

Regardless of which burner cleaning procedure you use, we recommend you also complete the following steps to help prolong burner life.

1. Use a brass wire brush to clean the entire outer surface of each burner until free of food residue and dirt.
2. Clean any clogged ports with a stiff wire, such as an open paper clip.
3. Inspect each burner for damage (cracks or holes) and if such damage is found, order and install a new burner. After installation, check to insure that the gas valve orifices are correctly placed inside the ends of the burner tubes. Also check the position of your spark electrode.

⚠ WARNING

The location of the burner tube with respect to the orifice is vital for safe operation. Check to ensure the orifice is inside of the burner tube before using your gas grill. See **ILL. 2**. If the burner tube does not fit over the valve orifice, lighting the burner may cause explosion and/or fire.

ILL. 2.

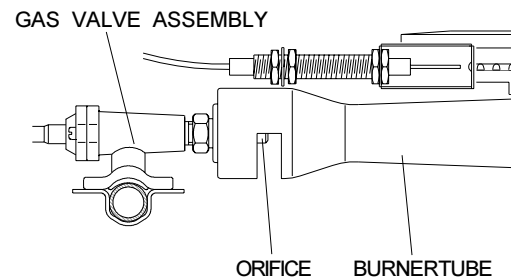

Frequently Asked Questions

Question: Who do I call with questions about grill assembly or if parts are damaged or missing from my shipping box?

Answer: Call the Customer Service Helpline 8am - 4:30pm CST, Monday through Friday, at **1-800-770-9769**

Question: Can I convert my Members Mark gas grill from one fuel type to another?

Answer: Your Members Mark gas grill is manufactured to exact specifications and is approved by the Canadian Standards Association (CSA) for LP gas use only. For your own safety, conversion kits are not available and any attempt to convert your grill from LP gas to Natural Gas will void your product warranty.

Question: Why doesn't the hose and regulator assembly supplied with my new gas grill fit the older LP gas tank I've used for years?

Answer: The U.S. Government regulates gas appliances and LP gas tanks. Whenever new regulations are passed the LP gas tank fittings are altered. If your current tank does not fit the hose and regulator supplied with your new grill, the tank is outdated and must be replaced.

Question: How do I season cooking grids?

Answer: Before and after each cookout, apply a thin layer of cooking oil, spray or vegetable shortening to each cooking grid. Be sure to coat the entire surface including edges.

Question: Sometimes my grill does not light when I push the ignitor button. Why?

Answer: Refer to the Lighting Instructions in this owner's manual. Also check these common causes.

- Ignitor AA battery may need replacing.
- Ignitor wires may be loose. Remove the AA battery, inspect the Ignitor junction box found behind the Control Panel, and connect any loose wires.

Question: What is the best way to protect my new Members Mark gas grill from the weather?

Answer: A good quality grill cover should be used to protect your grill when not in use. Also, follow the cleaning and maintenance instructions in this owner's manual on a timely basis, and your new grill will give you years of enjoyment.

Question: Where can I buy replacement parts?

Answer: For the repair or replacement parts you need call 8 am -4:30 pm CST, 1-800-770-9769. Use only Members Mark authorized parts. The use of any part that is not authorized can be dangerous and will also void your product warranty.

Question: Sometimes I hear a humming sound coming from my regulator. What causes this?

Answer: The humming noise is actually the gas flowing through the regulator. A low volume of noise is perfectly normal and will not interfere with the operations of the grill. If humming noise is loud and excessive you may need to purge air from the gas line or reset the regulator excess gas flow device. **Note:** This purging procedure should be done every time a new LP gas tank is connected to your grill. For help with this procedure refer to page 12 step 4, or call the **Customer Service Helpline, 8am - 4:30pm CST, Monday through Friday at 1-800-770-9769**

Customer Service Helpline: If you have questions about assembly or grill operation, or if there are damaged or missing parts when you unpack this unit from the shipping box, call us 8 : 00 am - 4 : 30 pm CST, Monday through Friday at: **1-800-770-9769**

Cooking Instructions

WARNING

Your grill will get very hot. Never lean over the cooking area while using your grill. Do not touch cooking surfaces, grill housing, grill lid or any other grill parts while the grill is in operation, or until the grill has cooled down after use.

Failure to comply with these instructions may result in serious bodily injury.

Burn-off

Before cooking on your gas grill for the first time, you will want to "burn off" the grill to eliminate any odor or foreign matter. Just ignite the burners, lower the lid, and operate grill on the HIGH setting for three to five minutes.

CAUTION:

Operating your grill on the HIGH setting for longer than five minutes may damage certain parts of your grill. **Do not leave your grill unattended.**

Preheating

To preheat, light your grill on HIGH, lower the lid and follow this timetable:

- For high temperature cooking, preheat grill 5 to 10 minutes.
- For low temperature cooking, preheat grill 3 minutes.
- To slow cook, preheating is not necessary.

Cooking Temperatures

High setting: Only use this setting for fast warm-up, searing steaks or chops and for burning food residue off the grill after cooking is complete. **Never** use the HIGH setting for extended cooking.

Medium to Low settings: Most recipes specify medium to low settings, including all smoking, rotisserie cooking and for cooking lean cuts such as fish.

NOTE: Temperature settings will vary with the amount of wind and temperature outside your home.

Direct Cooking

The direct cooking method can be used with the supplied cooking grids and food placed directly over the lit grill burners. **Direct cooking requires the grill lid to be up.** This method is ideal for searing and whenever you want meat, poultry or fish to have an open-flame barbecued taste. Deep frying and smoking are also best cooked in this manner because they require direct heat.

Indirect Cooking

The indirect cooking method can also be used with the supplied cooking grids. To cook **indirectly**, the food should be placed on the left or right side of your grill with the burner lit on the opposite side. Or place your food on the secondary cooking rack mounted inside your grill bowl and light the outer grill burners. Either way, **indirect cooking must be done with the lid down.**

Seasoning Cooking Grids

Before and after each cookout, apply a thin layer of cooking oil, spray or vegetable shortening to each cooking grid. Be sure to coat the entire surface including edges.

Flare-Ups

The fats and juices dripping from grilled food can cause flare-ups. Since flare-ups impart a favorably, distinctive taste and color to food cooked over an open flame, they should be accepted up to a point. Nevertheless, uncontrolled flaring can result in a ruined meal.

WARNING

Do not line the bottom of the grill housing with aluminum foil, sand or any substance that will restrict the flow of grease into the grease draining tray and receptacle.

Failure to comply with these instructions could result in a fire or explosion which could cause serious bodily injury, death, or property damage.

CONGRATULATIONS

Your Member's Mark gas grill is **now ready to grill**. Remember to keep the lid up when cooking directly on the grill. For most foods it's best to start grilling on high. Once the food is seared, reduce the heat to medium. Foods marinated with ingredients such as honey may burn because of the high sugar content. You should begin their cooking on medium. A favorite on the grill is sausages. Always cook them slowly and if they're particularly fatty, it may be best to partially boil them first.

Guide to Grilling Meat and Poultry with the Direct Cooking Method

Grilling Steak and Ribs

Turn the grill burners on high, close the lid and preheat your grill 3 to 5 minutes. Open lid and place the meat on the cooking grid directly above the lit burners. Cook the meat on both sides until seared. Reduce the heat to medium and cook meat until done. Grilling times will vary according to meat thickness.

Grilling Hamburger and Sausages

Turn the grill burners on high, close lid and preheat your grill 3 to 5 minutes. Open lid and place the meat on the cooking grid directly above the lit burners. Cook the meat on both sides until seared. Reduce the heat to medium and cook the meat until done. Grilling times will vary according to meat thickness.

Grilling Poultry

Turn the grill burners on high, close lid and preheat your grill 2 to 3 minutes. Then raise the lid, reduce heat to medium and cook poultry directly over lit burners until done. Poultry skin is fatty so you should expect some flare-ups when using this direct method.

To minimize flare-ups, try grilling poultry using the indirect method. Place the poultry on one side of the grill with the opposing burners on medium heat, and lower the grill lid. Grilling times will vary based on the size of your poultry.

Grilling Pork

Turn burners on high and preheat your grill 3 to 5 minutes with the lid down. Raise lid, place pork on cooking grid and cook until seared. Reduce heat to medium and cook until done. Grilling times will vary according to meat thickness.

Cut of Meat

T-bone steak
Sirloin steak
Beef spare ribs
Porter house steak
New York strip steak

Hamburgers
Sausages

Chicken breast
(cook with bone down)
Chicken wings
Drumsticks

Whole bird
(cook with breast up)

Pork spare ribs
Chops
Loins
Cutlets

Approximate Cooking Times

Rare: 4-8 minutes
Medium: 10-14 minutes
Well done: 15-20 minutes

Rare: 4-6 minutes
Medium: 8-10 minutes
Well done: 10-15 minutes

Direct method:
approximately 15 minutes

Indirect method:
up to 30 minutes

Indirect method:
approximately 1 hour

Rare: 4-8 minutes
Medium: 10-14 minutes
Well done: 15-20 minutes

Guide to Grilling Fish and Seafood with the Direct Cooking Method

Whole Fish and Whole Fillets

Preheat your grill on HIGH for 2-3 minutes with the lid down. Raise lid and turn burners to medium heat. Place fish (skin down) on grill and cook over direct heat until done. Use cooking time as a guide or until fish is opaque but still moist.

Cut of Meat

Whole fish
Whole fish fillets

Approximate Cooking Times

10 - 12 minutes per pound or until fish is opaque

Smaller Fish Fillets and Cubes

Follow the directions from above, using approximate cooking times shown at right. Place a small piece of aluminum foil on the cooking grids if the fish pieces are small enough to drop between the cooking grids.

Fish fillets
Boneless cubes

4 - 5 minutes each side or until fish is opaque

Guide to Grilling Vegetables and Fruit

Prepare your fruit or vegetables and brush with butter or basting sauce if desired. To cook **indirectly**, the food should be placed on the left or right side of your grill with the burner lit on the opposite side and the grill lid down. Or center your food on the secondary cooking rack and light the outer grill burners. Either way, **indirect cooking must be done with the lid down.**

In some instances, you may want to grill vegetables and fruit **directly** over the heat, using the supplied cooking grids or an optional griddle. Foods that work best with direct heat are relatively soft and require a short cooking time; mushrooms, zucchini, tomatoes and skewered fruit such as apricots, peaches, pineapple, strawberries and kiwis. Remember the **grill lid must remain up when cooking directly.** For very firm vegetables—particularly potatoes and yams, we recommend that you partially boil until almost cooked, before placing them on the grill.

Cooking times using the **indirect method** with the hood down will be similar to those for your kitchen oven. However, there are many factors such as outside temperature, wind conditions and location of grill that affect your grill performance so we suggest you watch the grill thermometer and adjust the heat accordingly.

Cooking times for foods prepared with the **direct method** will be much shorter mainly because of the direct heat source and softness of the food. Timing will be comparable to normal pan frying or grilling.

Guide to Slow Roasting and Baking Techniques

An Important Note About Heat Settings

The suggested heat settings shown are approximate. There are many factors such as outside temperature, wind conditions and grill location that affect your grill performance. We offer these cooking times as a convenience, but suggest you watch the grill thermometer and adjust the heat accordingly.

Preparing to Roast

Roasting uses the **indirect cooking** method. Therefore, the food should be placed on the left or right side of your grill with the burner lit on the opposite side. Place your meat inside an optional roasting rack and cooking pan that allows you to collect juices for making gravy. You can also use the supplied cooking grid with an aluminum drip pan underneath. Either way, indirect cooking requires the lid of your grill to be closed.

Preheating your grill is not required for slow cooking methods such as roasting. If you do choose to preheat your grill before roasting, turn the burners on high and close lid for approximately 2-3 minutes.

Food preparation

Trim meat of excess fat. Truss meat and poultry with cooking string to retain shape if desired. Bacon strips can be used to cover the outside surface of lean meat and poultry to help prevent it from drying out. Another method for keeping food moist during roasting is to put water in a cooking pan, then cover with foil. The foil should be removed for the first or the last part of the cooking time to ensure proper browning.

Tips for roasting

Except when roasting with water in the roasting pan, the juices that collect in the pan can be used as the base for a tasty sauce or gravy. Place a cooking pan directly over the heat, add extra butter if needed, then add several spoonfuls of flour to thicken sauce. Finally, add sufficient chicken or beef stock to obtain the desired consistency.

Once the meat is cooked, remove it from your grill and cover with a piece of foil. Allow it to stand for 10-15 minutes which allows the juices to settle. This will make carving easier and ensure a tender juicy roast.

Type of Food	How Cooked	Approximate Cooking Times
Beef	Rare	18 minutes per pound
	Medium	23 minutes per pound
	Well done	27 minutes per pound
Lamb	Medium	18 minutes per pound
	Well done	23 minutes per pound
Veal		27 minutes per pound
Pork		30-33 minutes per pound
Chicken		20-25 minutes per pound
Duck		25 minutes per pound
Fish		10 minutes per pound
Turkey, under 16 pounds		20-25 per pound + 30 minutes
Turkey, over 16 pounds		18-23 per pound + 15 minutes

BAKING TECHNIQUES

From casseroles and cornbread to delicious deserts like fondue fruit skewers or crumb cake, baking on the grill is as easy as baking in the kitchen.

Preparing to Bake

To bake in your new grill you'll need a baking dish or cast-iron cooking pan, and a pair of insulated cooking mitts. If the cooking pan is cast-iron be sure to season the pan before use.

Preheat your grill 3-5 minutes, then lower heat to achieve the baking temperature desired. Baking uses the

Oven Temperature

Slow	300° - 340° F
Moderate	355° - 390° F
High	410° - 480° F

indirect cooking method. Therefore, your cooking pan should be placed on the left or right side of your grill with the burner lit on the opposite side.

Tips for Baking

Prepare your favorite recipe as you would in the kitchen. Foods cooked in the grill for long periods of time should always be covered in aluminum foil to retain moisture. You will need to stir the food several times as it bakes, and add additional liquid if required.

Watch the temperature, and adjust to cook according to your recipe directions.

Recommended Grill Setting

Both outside burners on low
One outside burner on high and the other outside burner on low
Both outside burners on high

Guide to Rotisserie Cooking with The Back Burner

Rotisserie Cooking

Rotisserie cooking produces foods that are moist, flavorful and attractive. The optional rotisserie system is most commonly used for cooking meat or poultry and is designed to cook food from the back burner using infrared heat. The location of the burner allows the placement of a cooking pan beneath the food to collect juices for basting and gravy. To flavor the contents of the cooking pan you may add herbs, onions, or other spices of your choice. The back burner is an infrared type, which provides intense searing radiant heat. The intense heat sears in the natural juices and nutrients found in quality cuts of meat.

The cooking times on a rotisserie will be approximately the same as for oven cooking.

Balancing the Food

In rotisserie cooking, balancing the food is of utmost importance. The rotisserie must turn evenly or the stopping and starting action will cause the food to cook unevenly and possibly burn the heavier side.

The easiest foods to balance are those of uniform shape and texture. To test if the food is balanced correctly when secured, place the ends of the rotisserie spit loosely in the palms of your hands. If there is no tendency to roll, give the spit a quarter turn. If it is still stable, give it a final quarter turn. It should rest without turning in each of these positions. It can then be attached to your grill.

Food Preparation

When preparing poultry, truss the birds tightly so that wings and drumsticks are close to the body of the bird. The cavity of the bird may be stuffed prior to this. Pull the neck skin down and, using a small skewer, fix it to the back of the bird. Push the rotisserie spit through lengthwise, catching the bird in the fork of the wishbone. Center the bird and tighten with the holding forks. Test the balance as described before.

A rolled piece of meat requires the rotisserie skewer to be inserted through the center of the length of meat, then secured and balanced.

For meats that contain bones, it is best to secure the rotisserie skewer diagonally through the meaty sections. If protruding bones or wings brown too quickly, cover with pieces of foil.

Tips for Using The Back Burner

For back burner lighting instructions refer to page 10 of this Owner's Manual.

The location of the back burner makes it more susceptible to winds that will decrease the performance of your rotisserie cooking. For this reason you should not operate the back burner during windy weather conditions.

For best results, always rotisserie cook with the grill lid down and the Back Burner control knob set to HIGH. Do not use the main grill burners when the Back Burner is in operation.

Guide to Using The Smoker Drawer

Preparing to Smoke

Smoking gives food a distinctive, delicious flavor. You will find a variety of wood chips or pellets available for use in smoking grilled foods. Pre-soaking of wood chips may be required so read and follow the manufacturer's instructions for preparation of smoking chips prior to filling the smoker drawer.

Using The Smoker Drawer

Start your grill and allow it to reach the desired cooking temperature for the food you are grilling. Wear an insulated cooking glove and pull the smoker drawer out of the grill and fill with your prepared smoking chips. Dried herbs and spices may also be added to produce different flavors. Return the smoker drawer to the grill, ignite the smoker drawer burner. See instructions on Page 11, the heat will produce smoke and season the food.

Tips for Smoking

You can reduce the strength of the smoke flavor by only smoking for half or three quarters of the cooking

time. The heat required for smoking is normally low to medium.

Foods naturally high in oils lend themselves well to smoking, while drier foods benefit from a marinade. You can also rub the food with herbs, spices or flavored oils. Many foods can be smoked to produce stunning results with very little effort. Here are a few suggestions:

- **Tuna steaks**, marinated in Asian flavors of sesame oil, soy sauce and sherry.
- **Pork filets**, rubbed with ginger, orange rind and brushed with maple syrup.
- **Mussels**, brushed with lemon rind and chili oil.
- **Lamb cutlets**, marinated in virgin olive oil, lemon, oregano and black pepper. The same marinade can be used for a whole leg or rack of lamb.
- **Chicken**, boneless chicken pieces—especially sliced breasts
- **Fish**, sliced filets of firm fish, assorted seafood such as prawns, scallops and calamari
- **Pork**, sliced filets, diced or minced pork, sliced leg steak, sliced chops
- **Beef**, sliced fillet, rib-eye, round, rump, sirloin
- **Lamb**, sliced fillet, round, loin

Guide to Stir-Frying and Deep-Frying

STIR-FRYING TECHNIQUES

This method of cooking is popular around the world and can be easily accomplished outdoors on your Kenmore gas grill. It's a quick and healthful way of preparing a complete meal using meat, poultry or seafood in infinite combinations with other interesting ingredients like vegetables, rice or noodles.

Preparing to Stir-fry

Although it is possible to stir fry in other dishes, the wok is your best tool. Its high sides enable the cook to stir food without spillage. Its construction allows you to cook quickly at high temperatures, with instant control of heat which is essential for successful stir frying.

Food preparation

Slice meat and poultry into long thin strips and cube fish fillets. Remove all fat from meat and poultry and cut large vegetables into even slices or cubes.

Marinate foods for extra flavor and tenderness. Marinating times will vary for red meat, fish and or various cuts. Less tender cuts of meat should be marinated longer. Remember to always chill marinating food in the refrigerator prior to cooking.

Stir-fry meats, poultry or fish first. Next, add hard vegetables like carrots. Then continue with softer vegetables like snowpeas and peppers. To ensure even cooking, continually stir and toss the food in the wok using a wooden spoon or spatula.

Tips for Stir-frying

Place the wok directly over a high heat on your grill or side burner. Add only a small amount of food at a time to ensure fast cooking and also to allow the wok to reheat between ingredients.

DEEP-FRYING TECHNIQUES

A wide variety of foods can be deep-fried outdoors on your grill, from potatoes, to seafood and chicken. Deep-frying uses a large portion of oil, preferably saturated. The outdoor location is ideal for deep-frying as smoke, grease and smells reach for the sky—not the ceiling of your kitchen.

Preparing to Deep-fry

Deep-fry on your grill using a cooking pan or wok, over direct heat with the grill lid raised.

Fill the cooking pan no more than half full of vegetable or corn oil. Start with low heat, then raise the heat gradually. Check the temperature of the oil carefully with a frying thermometer or test with a cube of bread. The cube of bread should brown in about 30 seconds for most cooking needs. A temperature between 350 and 400 degrees is optimal for preparing the majority of deep-fried foods.

Food Preparation

Foods being deep-fried taste better when coated with either batter or breadcrumbs to add flavor and prevent moisture from escaping.

Tips for Deep-frying

Wear an insulated cooking glove and slowly lower foods into the hot oil using a wire scoop or stainless steel tongs. Add only a small quantity of food to the oil, allow it to cook, then repeat with another small quantity. This ensures the oil doesn't drop in temperature. Once the food is cooked, remove it carefully and drain onto a paper towel. Turn the heat off as soon as you have finished deep-frying and allow the pan to cool. When the oil is cool, remove all remnants of fried foods by straining it through a fine metal sieve. Once the oil is quite cool, store it in a clean bottle for future use.

Guide to Using the Secondary Cooking Rack

Vegetables are generally easy to cook on the grill. The cooking rack makes it convenient because you can still use the main cooking area while the vegetables are suspended above the grids.

Pre-cook hard vegetables by briefly boiling or microwaving them before cooking on the grill. Wrap vegetables in a double thickness of foil to protect them while cooking on the grill. Then, remove the foil if desired, 10-15 minutes before the end of cooking, brush vegetables with butter or oil and finish cooking.

The cooking rack can be used for purposes other than just the obvious. Consider using it for warming French bread, garlic bread, croissants or even bagels. A small whole fish wrapped in foil also cooks well in the cooking rack. Parcels of seafood such as scallops, prawns and sliced fish fillets prepared in a sauce and portioned into small foil wraps cooks well this way, too.

Recipes

ONION BURGERS

A honey and mustard sauce glazes the onion slices as they cook alongside these delicious burgers. For optimal sweetness, select Vidalia or Walla Walla onions. **Makes 4 open face burgers.**

Ingredients

- 2 large sweet onions, sliced (12 to 16 ounces)
- 2 tablespoons margarine or melted butter
- 2 teaspoons dry mustard
- 2 teaspoons honey
- 1 pound lean ground beef
- 1/4 teaspoon salt
- 1/8 teaspoon pepper
- 4 slices Texas toast
- 4 lettuce leaves
- 4 tomato slices

Preparing Onions

Place onions in a cooking pan or on a small piece of aluminum foil. Combine melted margarine, mustard and honey, then drizzle over onions. Cover pan with lid or fold up edges of foil and seal with double fold to completely enclose onions—leaving space for steam to build. Place pan or foil packet on grill directly over medium heat for 15 minutes with the grill hood up.

Preparing Burgers

While onions are cooking, combine ground beef, salt and pepper in a medium bowl and mix well. Shape mixture into four 3/4 inch burger patties and add to grill, directly over heat. Grill burgers along with onions for about 5 minutes, then turn burgers. Grill for 8 to 10 minutes more or until no pink remains in meat, and onions are tender. To serve, toast both sides of Texas toast on grill. Then top each slice of Texas toast with a burger, lettuce, tomato and onion. Sprinkle with pepper if desired.

DOUBLE SALSA BURGERS

A fresh tomato salsa flavors the beef mixture for a zesty tasting burger. The salsa also serves as a colorful topping. **Makes 6 burger patties.**

Ingredients

- 1 large tomato, seeded and finely chopped
- 1/2 cup finely chopped green pepper
- 1/4 cup finely chopped red onion
- 2 finely chopped, seeded jalapeno peppers
- 1 garlic clove, minced
- 1 tablespoon snipped cilantro

- 1/4 teaspoon salt
- 1 1/2 pounds lean ground beef
- 2 cups shredded lettuce
- 1/3 cup finely shredded cheddar cheese
- 1/4 cup dairy sour cream and /or guacamole

Preparing the Salsa

Combine tomato, green pepper, onion, jalapeno peppers, garlic, cilantro and salt in a bowl. Set aside 2 tablespoons of salsa. Cover and chill remaining salsa until serving time.

Preparing Burgers

In another bowl, combine ground beef with 2 tablespoons of reserved salsa, mix well. Shape mixture into six 1/2 inch thick burgers and place on the grill directly over medium heat with hood up. Grill for 13 to 15 minutes or until no pink remains. Turn burgers once, halfway through grilling time. Arrange the shredded lettuce on individual plates. Top lettuce with a burger, cheddar cheese and salsa. Serve with sour cream and/or guacamole.

CHICAGO STYLE HOT DOGS

Serve these hot dogs "Chicago-style" with pickled peppers! **Makes 4 servings.**

Ingredients

- 1/3 cup ketchup
- 1/4 cup chopped pickled peppers
- 2 tablespoons pickle relish
- 2 tablespoons chopped onion
- 1/4 teaspoon poppy seed
- 4 fully cooked 4-ounce jumbo hot dogs
- 4 hot dog buns

Preparing the Relish

Combine ketchup, chopped pickled peppers, relish, onion and poppy seed in a small bowl, then set aside.

Preparing Hot Dogs

Place hot dogs on grill directly over medium heat 5 to 8 minutes with the lid up. Turn hot dogs and brush with some of the relish mixture. Grill hot dogs 6 to 8 minutes more or until thoroughly cooked.

To Serve

Toast inner sides of hot dog buns on grill. Serve hot dogs inside buns and top with remaining relish mixture.

RIB EYE STEAKS WITH GRILLED GARLIC

As they cook, the garlic cloves mellow in flavor, making a delicious sauce for any grilled meat. And for an appetizer, spread the softened cloves over toasted slices of french bread! **Makes 4 servings.**

Ingredients

- 1 whole head of garlic
- 2 tablespoons olive oil or cooking oil
- 1 tablespoon snipped fresh basil, or 1/2 teaspoon dried basil, crushed
- 1 tablespoon snipped fresh rosemary or 1/2 teaspoon dried rosemary, crushed
- 2 twelve-oz. boneless rib eye steaks

Preparing the Garlic

Use a cooking pan or tear off a 24x18-inch piece of aluminum foil and fold long length in half, then trim to make a 12-inch square. Remove the outer layer of garlic head, then cut off and discard the top 1/2-inch of garlic head to expose the garlic cloves. Place garlic head in center of a cooking pan or in center of foil with all sides of the foil folded up around the garlic to form a cup. Drizzle garlic with oil and sprinkle with basil and rosemary. Cover pan or twist the ends of the foil to completely enclose the garlic.

Preparing Steaks

Place steaks and the garlic pack on grill directly over medium heat and cook about 7 minutes with the lid up. Turn steaks and grill for 5 to 8 minutes more, or until cooked to taste. Then remove steaks and place on platter. Remove garlic and drizzle its juices over your steak. Remove the softened garlic cloves and spread over your steak. Season with salt and pepper as desired and cut into serving-size pieces.

HERB-PEPPER SIRLOIN STEAK

The hearty beef flavor is complemented with a delicious herb coating! **Makes 6 servings.**

Ingredients

- 2 tablespoons ketchup
- 1/2 teaspoon coarsely ground pepper
- 1 1/2 teaspoons snipped fresh rosemary or 1/2 teaspoon dried rosemary, crushed
- 1 1/2 teaspoons snipped fresh basil or 1/2 teaspoon dried basil, crushed
- 1/8 teaspoon garlic powder
- 1 1 1/2-pound boneless beef sirloin steak, cut 1-inch thick

Preparation

Combine ketchup, pepper, rosemary, basil and garlic powder. Coat both sides of steak with mixture. Grill steak with hood up, directly over medium heat for 6 minutes. Turn steak and grill for 8 to 12 minutes more or until cooked as desired. Cut into serving size pieces.

BARBECUED RIBS

Serve this tangy barbecue classic with corn-on-the-cob, green salad, potato salad or coleslaw! **Makes 4 servings.**

Ingredients

- 2 pounds American style pork spareribs
- 1/2 cup barbecue sauce
- 1/2 cup tomato sauce
- 2 cloves garlic, crushed
- juice of 1 lemon
- few drops of tobasco sauce

Preparation

Place ribs into a large glass or ceramic dish. Combine remaining ingredients and pour over the ribs. Refrigerate for several hours.

Preheat your grill 3 minutes and place the ribs on cooking grid. Cook indirectly, over a low to medium heat until cooked. During the last few minutes of cooking you can cook the ribs over a direct fire for added barbecue flavor and texture.

MARINATED TUNA STEAK

Experiment with unique dishes, like this tuna steak recipe boasting a delicious wine marinade!

Makes 4 servings.

Ingredients

- 4 6-ounce fresh or frozen tuna steaks cut 1 inch thick. Thaw fish if frozen
- 1/3 cup dry white wine
- 1 tablespoon lemon juice
- 1 tablespoon olive oil or cooking oil
- 1 clove garlic, minced
- 2 teaspoons snipped fresh rosemary, crushed, or 1/2 teaspoon dried rosemary, crushed
- 1 teaspoon snipped fresh oregano, crushed, or 1/4 teaspoon dried oregano, crushed
- 1/4 teaspoon salt

Preparation

Combine wine, oil, garlic, rosemary, oregano and salt. Place tuna steak in plastic bag and into shallow dish, add marinade then seal bag. Rotate bag to coat fish well then chill for up to 2 hours, turning fish once.

Remove fish from bag and discard marinade. Place a cooking pan with baking rack or roasting rack into center of grill with outer burners on medium heat. Cook tuna steak on top of rack with lid down for 8 to 12 minutes or until fish begins to flake easily. Turn fish once during cooking. When cooked, remove fish from grill and serve.

MUSTARD-GLAZED HALIBUT STEAKS

A simple sauce of melted margarine, lemon juice, Dijon-style mustard and basil adds a scintillating note to these sizzling fish steaks! **Makes 4 servings.**

Ingredients

- 4 6-ounce fresh or frozen halibut steaks, cut 1 inch thick
- 2 tablespoons margarine or butter
- 2 tablespoons lemon juice
- 1 tablespoon Dijon-style mustard
- 2 teaspoons snipped fresh basil or 1/2 teaspoons dried basil, crushed

Preparation

Combine thawed fish, margarine or butter, lemon juice, mustard and basil into a cooking pan or aluminum foil rectangle, and cook directly over low flame until melted. Brush mixture over both sides of halibut fish steaks. Pour balance of mixture into small bowl.

Place clean cooking pan or foil on center of grill with both outer burners on medium. Place fish on grill and close lid. Cook indirectly for 8 to 12 minutes or just until fish begins to flake easily, turning once and brushing as needed with remaining mixture.

ALMOND COATED TROUT

This delicious recipe is unique and easy to prepare on your gas grill. **Makes 4 servings.**

Ingredients

- 2 trout
- 1/2 cup all purpose flour
- 1 egg, lightly beaten
- 1 cup sliced almonds
- 1/3 cup parmesan cheese, grated
- olive or peanut oil for frying

Preparation

Remove the head and tail from trout and fillet all bones. Cut each fish in half to form 4 long fillets. Coat fish in flour, dip in egg and roll in almonds. Refrigerate for 1 hour.

Fill a cast-iron pan with 1 to 2 inches of oil, and place over high heat. Cook trout until golden brown. Drain oil, sprinkle trout with parmesan cheese and serve right from the grill.

SOUTHWEST CHICKEN BREASTS

This popular recipe can also be a grilled chicken salad! Slice chicken into small strips and place them on top of shredded lettuce with avocado dressing and top with cheese! **Makes 6 servings.**

Ingredients

- 1/4 cup dry white wine
- 2 tablespoons olive oil or cooking oil
- 2 teaspoons snipped fresh tarragon or 1/4 teaspoon dried tarragon, crushed
- 1/4 teaspoon salt
- 6 skinless, boneless chicken breast halves
- 2 avocados, pitted, peeled and chopped
- 1 tomato, chopped
- 1 clove garlic, minced
- 2 tablespoons finely chopped seeded green chili peppers of your choice
- 2 green onions, finely chopped
- 1 tablespoon snipped fresh cilantro
- 1 tablespoon honey
- 1 tablespoon lemon juice

Preparing the Chicken

Combine wine, oil, tarragon and salt. Rinse chicken and dry with paper towels. Place chicken in plastic bag and into shallow dish—then add marinade and seal bag. Rotate chicken to coat well and chill up to 24 hours, turning bag occasionally.

Preparing the Avocado Dressing

Combine avocados, tomato, garlic, chili peppers, onions, cilantro, honey and lemon juice. Toss well then cover and chill up to 2 hours.

Grilling the Chicken

Remove the chicken from plastic bag and reserve the marinade. Grill chicken directly over medium heat with lid up for 5 minutes. Turn chicken and brush with marinade, then grill for 5-10 minutes more or until chicken is no longer pink. Serve with side of avocado dressing.

BARBECUED CHICKEN

Another backyard favorite, this recipe includes an easy to make, sweet and spicy sauce.

Makes 4 servings.

Ingredients

- 1/2 cup ketchup
- 1/4 cup orange marmalade
- 1 tablespoon vinegar
- 1/2 teaspoon celery seed
- 1/2 teaspoon chili powder
- 1/4 to 1/2 teaspoon bottled hot pepper sauce
- 1 2 1/2 to 3 pound broiler-fryer chicken, pre-cut

Preparing the Sauce

Combine ketchup, marmalade, vinegar, celery seed, chili powder and hot pepper sauce in a cooking pan, and cook directly over a low to medium heat. Leave the cooked sauce in the pan and remove from heat until chicken is prepared.

Preparing the Chicken

Wash chicken and dry with paper towels. Turn outside burners on medium and place pre-cut chicken pieces (bone side down) in center of grill. Close lid and cook indirectly for 1 hour or until chicken is no longer pink. Brush occasionally with sauce. Remove chicken from grill once cooked, then place cooking pan with sauce into center of grill and reheat. Pour warmed sauce over chicken and serve.

TRADITIONAL HOLIDAY TURKEY

Imagine everyone's surprise when you serve your next holiday turkey—complete with dressing—delicious and tender straight from the grill! **Serves 8 - 10**

Ingredients for Turkey

- 8 - 10 pound whole turkey
- 4 ounces butter, softened
- 2 tablespoons chopped thyme
- 2 tablespoons lemon juice
- 2 teaspoons grated lemon rind

Ingredients for Dressing

- 2 ounces butter
- 2 onions, finely chopped
- 8 ounces bacon, chopped
- 2 tablespoons port wine
- 1/4 cup red wine
- 2 chicken stock cubes
- 4 ounces chopped cashews, hazelnuts or pecans
- 1/2 cup chopped celery
- 1/2 cup chopped carrot
- 1 - 1 1/2 cups fresh white breadcrumbs
- 1 egg, lightly beaten
- salt and pepper to taste

Preparing the Dressing

Prepare dressing in a cooking pan directly over medium heat. Melt butter, add onions and bacon then saute 3 minutes. Add port, red wine and stock cubes and bring to a boil. Cook 2 minutes. Remove pan to allow ingredients to cool. Add remaining ingredients and mix.

Preparing the Turkey

Although not required, you may want to preheat your grill 3 minutes.

Wash inside of turkey and dry with paper towels. Pack breadcrumb seasoning into the turkey cavity. Combine the butter, thyme, lemon juice and rind together in a bowl. Using turkey baster, insert butter mixture under skin covering the turkey breast.

Truss the turkey with string and place it on a baking pan or roasting rack that rests into a cooking pan. Remove the cooking grids from your grill if necessary, then place the cooking pan and turkey in the center of your grill. Turn one outside burner to low, the other to medium, and close lid. Cook indirectly for 3 1/2 to 4 hours or until cooked. Halfway through cooking time you may alternate burner temperatures so that the turkey browns evenly. Once cooked, remove dressing from cooked turkey, slice and serve.

PIZZA ON THE GRILL

You may never want to call out for pizza again! Follow this pizza dough recipe, or purchase ready-made pizza dough found in your grocers refrigerated section—next to the biscuits. Slice and serve directly from the grill. **Serves 6 - 8**

Ingredients

- 1 1/2 teaspoons dried yeast
- 1 cup lukewarm water
- 1/2 teaspoon sugar
- 3 tablespoons olive oil
- 3 cups all purpose flour
- 1/4 cup tomato paste or Italian tomato sauce
- 6 ounces sliced pepperoni
- 1 red pepper, roasted and sliced
- 3/4 cup pitted black olives
- 8 ounces grated mozzarella cheese

It's easy to customize this recipe with toppings to suit your family's taste. For spicier crust, lightly rub the dough with olive oil then spice with pepper and garlic salt before spreading your tomato sauce.

Preparing the Pizza Dough

Combine yeast, water and sugar together and let stand in a warm place until mixture starts to foam. Add this yeast mixture to flour and oil and combine to form your pizza dough. Knead on a lightly floured surface until smooth and elastic. Cover and stand in a warm place until doubled in size. Knock back dough and roll out to a rectangle the size of your cooking pan or baking dish. Place dough into a lightly oiled pan.

If you purchased a ready-made pizza dough, simply open can and roll dough into a lightly oiled cooking pan.

Preparing the Pizza

Spread tomato paste or Italian tomato sauce on top of your pizza dough. Top with pepperoni, red peppers, olives, and lastly, mozzarella cheese. Or if you prefer, you may place cheese first with toppings on last.

Place cooking pan in center of grill and cook indirectly, with one outside burner on high and the other on low, for approximately 20 minutes or until bottom of crust is light brown. Lastly, raise the lid and finish cooking pizza by turning burner under the cooking pan on high for about 2 minutes. This will insure the center of pizza gets brown. Then turn off heat, slice and serve directly from pan.

FRESH VEGETABLE STIR-FRY

Take a trip to the Orient with this easy, and healthy vegetable recipe. **Makes 4 - 6 servings.**

Ingredients

- 2 tablespoons oil
- 1 onion, cut into wedges
- 1 carrot, thinly sliced
- 2 cups broccoli, cut into small flowerets
- 1 red pepper, sliced
- 2 sticks celery, thinly sliced
- 1 cup snow peas
- 1/2 cup chicken broth

Preparation

Heat oil in a wok or saute pan, directly over a high heat. Add onion and cook 1 minute. Add carrot and broccoli and stir-fry 2 minutes, then add red pepper, celery and snow peas and continue cooking 1 minute more. Add chicken broth and toss vegetables until cooked to desired doneness.

ONION BLOSSOMS

Great served as a snack, or to dress up barbecued meats, poultry or fish. **Makes 4 servings.**

Ingredients

- 4 medium sweet onions (4-5 ounces each)
- 1 tablespoons margarine or butter, melted
- 1 teaspoon Dijon-style mustard
- 1/8 teaspoon hot pepper sauce
- 1 tablespoon brown sugar
- 1 pepper (optional)

Preparation

Peel onions, then cut almost completely through each onion, forming 8 wedges. Onion will be loose, but still be intact. Prepare four 12-inch squares of aluminum foil. Place one onion in the center of each foil square.

Stir margarine (or butter) with hot pepper sauce and drizzle over onions. Sprinkle with brown sugar. Then bring up two sides of foil square and double fold. Bring remaining corners up and completely enclose—leaving enough space for steam to build.

Place wrapped onion blossoms on grill, directly over medium heat. Close lid and cook 15 to 25 minutes or until onions are nearly tender. Make a 2-inch opening at the top of each onion wrapping, then close lid and cook 5 to 10 minutes more, or until onions are lightly browned. Sprinkle with pepper if desired and serve warm.

GRILLED POTATO SKINS

Serve these crispy potatoes as a snack or side dish. We've included microwave instructions for a timesaving short cut. **Makes 12 servings.**

Ingredients

- 6 baking potatoes (about 8 ounces each)
- 3 tablespoons margarine or butter, melted
- 1/2 cup picante sauce
- 1 cup shredded cheddar cheese (4 ounces)
- 3 slices bacon, crisp-cooked and crumbled or use prepackaged bacon bits
- 1 chopped tomato (optional)
- 1 diced green onion (optional)
- 1/2 cup sour cream (optional)

Preparation

Puncture clean potatoes with a fork, wrap in aluminum foil and place directly over low to medium heat. Close lid and cook directly for 1 hour or until center is tender. OR - Microwave clean, punctured potatoes on high for 15 to 20 minutes, or until center tender. Allow cooked potatoes to cool then unwrap and discard foil.

Cut potatoes in half - lengthwise. Scoop out potato pulp (serve separately or discard.) Be sure to leave 1/4-inch thick potato shell remaining. Brush the inside of each potato shell with melted margarine. Spoon 2 teaspoons picante sauce into each potato shell, sprinkle with cheese and top with bacon.

Place prepared potato skins on grill, directly over medium heat. Close lid and cook for 8 to 10 minutes or until potato skins are crisp. Sprinkle each potato skin with tomato and green onion and then top with sour cream, if desired.