

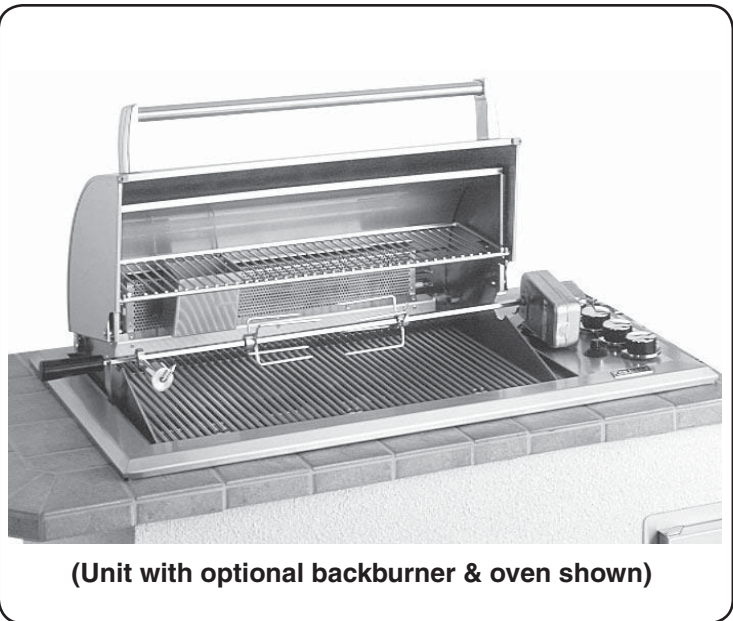

REGAL I DROP-IN SERIES 34 OUTDOOR GAS BARBECUE

INSTALLATION AND OPERATING INSTRUCTIONS

INSTALLER: Leave these instructions with consumer.
CONSUMER: Retain for future reference.



(Unit with optional backburner & oven shown)

Important: READ THESE INSTRUCTIONS CAREFULLY BEFORE STARTING INSTALLATION

SAFETY WARNINGS & CODES

▲ DANGER
IF YOU SMELL GAS:

1. Shut off the gas to the appliance.
2. Extinguish any open flame.
3. Open lid if equipped with an oven.
4. If odor continues, keep away from the appliance, and immediately call your gas supplier or fire department.

▲ WARNING

1. Do not store or use gasoline, or other flammable vapors and liquids, in the vicinity of this or any other appliance.
2. A propane cylinder not connected for use shall not be stored in the vicinity of this or any other appliance.

▲ WARNING
 Improper installation, adjustment, alteration, service, or maintenance can cause injury or property damage. Refer to this manual. For assistance or additional information consult a qualified, professional installer, service agency, or the gas supplier.

CODE AND SUPPLY REQUIREMENTS: This barbecue must be installed in accordance with local codes and ordinances or, in the absence of local codes, with either the current *National Fuel Gas Code (ANSI Z223.1NFPA 54)*, *Natural Gas and Propane Installation Code (CSA B149)*, or *Propane Storage and Handling Code (CSA B149.2)*.

This appliance and its individual shutoff valves must be disconnected from the gas supply piping system when testing the system at pressures in excess of ½ psig (3.5 kPa).

This appliance must be isolated from the gas supply piping system by closing its individual manual shutoff valves during any pressure testing of the gas supply system at pressures up to and including ½ psig (3.5 kPa).



Certified to ANSI: Z21.58

All electrical outlets in the vicinity of the barbecue must be properly grounded in accordance with local codes or, in the absence of local codes, with the ***National Electrical Code, ANSI/NFPA 70, or the Canadian Electrical Code, CSA C22.1***, whichever is applicable.

CAUTION: Keep all electrical supply cords and fuel supply hoses away from any heated surface.



BARBECUE EXTÉRIEUR De GAZ De la SÉRIE 34 MAJESTUEUX De I DROP-IN

INSTALLATION ET CONSIGNES D'UTILISATION

INSTALLATEUR : Laissez ces instructions avec le consommateur.

CONSOMMATEUR : Maintenez pour la future référence.

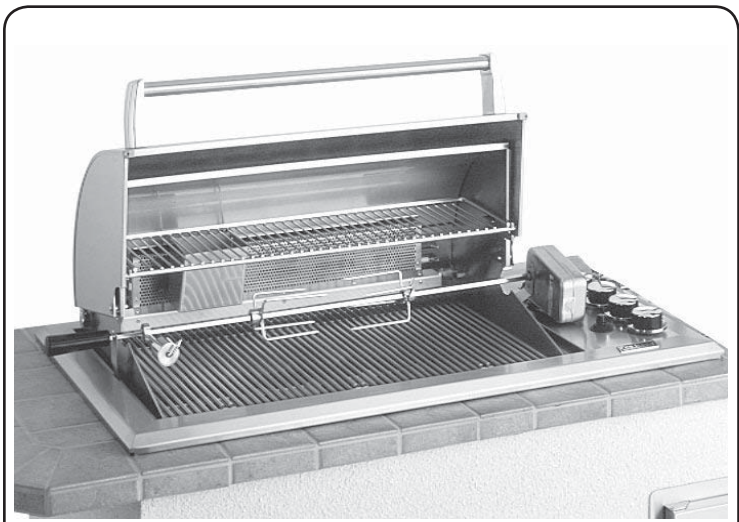

La photo montre l'unité avec le backburner et le four facultatifs.

Important: LISEZ CES INSTRUCTIONS SOIGNEUSEMENT AVANT DE COMMENCER L'INSTALLATION

AVERTISSEMENTS ET CODES DE SÛRETÉ

⚠ DANGER

SI VOUS SENTEZ LE GAZ :

1. Coupez le gaz à l'appareil.
2. Éteignez-vous n'importe quelle flamme nue.
3. Ouvrez le couvercle si équipé d'un four.
4. Si l'odeur continue, gardez loin de l'appareil, et appelez immédiatement votre département de fournisseur ou de feu de gaz.

⚠ AVERTISSEMENT

1. Ne stockez pas ou n'employez pas l'essence, ou d'autres vapeurs et liquides inflammables, à proximité de ceci ou d'aucun autre appareil.
2. Un cylindre de propane non relié pour l'usage ne sera pas stocké à proximité de ceci ou d'aucun autre appareil.

⚠ AVERTISSEMENT

L'installation inexacte, l'ajustement, le changement, le service, ou l'entretien peuvent causer des dommages ou des dégâts matériels. Référez-vous à ce manuel. Pour l'aide ou l'information additionnelle consultez un installateur qualifié et professionnel, l'agence de service, ou le fournisseur de gaz.

CONDITIONS DE CODE ET D'APPROVISIONNEMENT : Ce barbecue doit être installé selon des codes et des ordonnances locaux ou, en l'absence des codes locaux, avec le code national courant de gaz de carburant (norme ANSI Z223.1NFPA 54), gaz naturel et code d'installation de propane (CSA B149), ou stockage de propane et le code de manipulation (CSA B149.2).

Cet appareil et ses différents robinets d'isolement doivent être démontés du système sifflant d'offre de gaz en examinant le système aux pressions au-dessus du ½ psig (kPa 3.5).

Cet appareil doit être isolé dans le système sifflant d'offre de gaz par fermeture ses différents robinets d'isolement manuels pendant tous les essais sous pression du circuit d'alimentation de gaz aux pressions jusques et y compris le ½ psig (kPa 3.5).



Certifié à la norme ANSI : Z21.58

Toutes les sorties électriques à proximité du barbecue doivent être correctement fondues selon des codes locaux ou, en l'absence des codes locaux, avec **Code électrique national, ANSI/NFPA 70, ou le code électrique canadien, CSA C22.1**, celui qui est applicable.

ATTENTION: Maintenez tous les cordes d'alimentation électrique et tuyaux d'approvisionnement en carburant partis de n'importe quelle surface de chauffage.

TABLE OF CONTENTS

1	SAFETY WARNINGS & CODES
3	TABLE OF CONTENTS
5	PARTS LIST
6	FIRE MAGIC REGAL I DROP-IN SERIES (w/ BACKBURNER) PARTS LIST
7	FIRE MAGIC REGAL I DROP-IN BACKBURNER & OVEN PARTS LIST (WHERE FITTED)
8	MODEL SPECIFICATIONS
8	BUILT-IN GRILL DIMENSIONS TABLE
9	INSTALLATION REQUIREMENTS
10	ENSURING PROPER COMBUSTION AIR AND COOLING AIRFLOW
10	GAS-SUPPLY PLUMBING REQUIREMENTS
11	ENCLOSURE REQUIREMENTS
11	NATURAL GAS INSTALLS
11	PROPANE GAS INSTALLS (HOUSEHOLD & CYLINDER)
11	WHEN A PROPANE CYLINDER IS USED
13	SAFE USE & MAINTENANCE OF PROPANE GAS CYLINDERS
14	INSTALLATION
15	CHECKING AND CONVERTING GAS TYPE
15	CHECKING AND CONVERTING THE REGULATOR
16	CHECKING/CONVERTING THE BURNER ORIFICES
18	AIR SHUTTER ADJUSTMENT
18	MAIN BURNER AIR SHUTTER ADJUSTMENT
18	BACKBURNER AIR SHUTTER ADJUSTMENT
19	BARBECUE SAFETY INFORMATION & MAINTENANCE
19	DRIP COLLECTION SYSTEM
21	LIGHTING (IGNITION) INSTRUCTIONS
21	ELECTRONIC LIGHTING
21	MANUAL LIGHTING
22	ROTISSERIE INSTRUCTIONS
23	ACCESSORIES
24	CARE & CLEANING
25	TROUBLESHOOTING
25	REPLACING THE IGNITOR BATTERY
26	WARRANTY

Avertissements généraux :

- Ce barbecue est pour utilisation à l'extérieur seulement. Si l'appareil est entreposé à l'intérieur, enlever les bouteilles et les laisser à l'extérieur.
- Ne pas ranger le gril immédiatement après l'avoir utilisé. Le laisser refroidir avant de le déplacer ou de la ranger. Le non respect de cette mesure de sécurité pourrait entraîner un incendie causant des dommages à la propriété, des blessures ou la mort.
- Ne pas utiliser cet appareil sous une surface combustible.
- Ne pas utiliser cet appareil sous un auvent. Le non respect de cette mesure de sécurité pourrait entraîner un incendie ou des blessures.
- Dégagement minimal entre les parois latérales et l'arrière de l'appareil et la construction combustible (45.7 cm à partir des parois latérales et 45.7cm à partir de l'arrière).
- Le régulateur de pression de gaz prévu avec cet appareil de cuisson à gaz pour l'extérieur doit être utilisé. Ce régulateur est réglé pour une pression de sortie de 5 pouces de colonne de l'eau pour le gaz naturel, et 10 pouces pour le propane.
- LE RÉGULATEUR INCLUS D'APPAREILS EST ÉVALUÉ POUR LE MAXIMUM DE 1/2 (LIVRES PAR POUCE CARRÉ). SI VOTRE OFFRE DE GAZ EST 1/2 PLUS GRAND QUE (LIVRES PAR POUCE CARRÉ), UN RÉGULATEUR ADDITIONNEL DOIT ÊTRE INSTALLÉ AVANT LE BARBECUE. VOIR LA SECTION DE CONDITIONS D'OFFRE DE GAZ POUR LA PRESSION APPROPRIÉE D'OFFRE DE GAZ.
- Ne couvrez jamais la surface entière de cuisine ou de gril de gauffreuses ou de casseroles. La surchauffe se produira et les brûleurs ne seront pas très performants quand la chaleur de combustion est emprisonnée au-dessous de la surface à cuire.
- Ne pulvérisez jamais l'eau sur une unité chaude de gaz, comme ceci peut endommager des composants de porcelaine ou de fer de fonte.

Avertissements de propane :

- Une fuite de GPL peut causer un incendie ou une explosion si enflammée entraînant des blessures corporelles graves ou la mort.
- Communiquez avec le fournisseur de GPL pour les réparations ou pour disposer de quales bouteille ou du GPL non utilisé.

PARTS LIST

- | Item | Description |
|------|--|
| 1. | TOP PANEL (STAINLESS STEEL) |
| or | TOP PANEL (PORCELAIN) |
| 2. | 18"X10" COOKING GRID (STAINLESS STEEL) |
| or | 18"X10" COOKING GRID (PORCELAINIZED CAST IRON) |
| 3. | FLAVOR GRID 7" |
| 4. | FLAVOR GRID 10" (2) |
| 5. | BURNER (6) |
| 6. | AIR SHUTTER SPRING (6) |
| 7. | AIR SHUTTER (6) |
| 8. | ORIFICE (NAT GAS) |
| or | ORIFICE (PROPANE GAS) |
| 9. | VALVE MANIFOLD W/ VALVE & REGULATOR |
| 10. | BURNER MANIFOLD (3) |
| 11. | 15.5" FLEX TUBE ASSEMBLY |
| 12. | 34" FLEX TUBE ASSEMBLY |
| 13. | 48" FLEX TUBE ASSEMBLY |
| 14. | CONTROL KNOB (3) |
| 15. | IGNITOR ASSEMBLY |
| 16. | GROUND WIRE |
| 17. | ELECTRODE COLLECTOR ASSEMBLY |
| 18. | DRIP TRAY |
| 19. | DISPOSABLE DRIP TRAY LINER |

Replacement parts can be ordered from your local Fire Magic dealer.

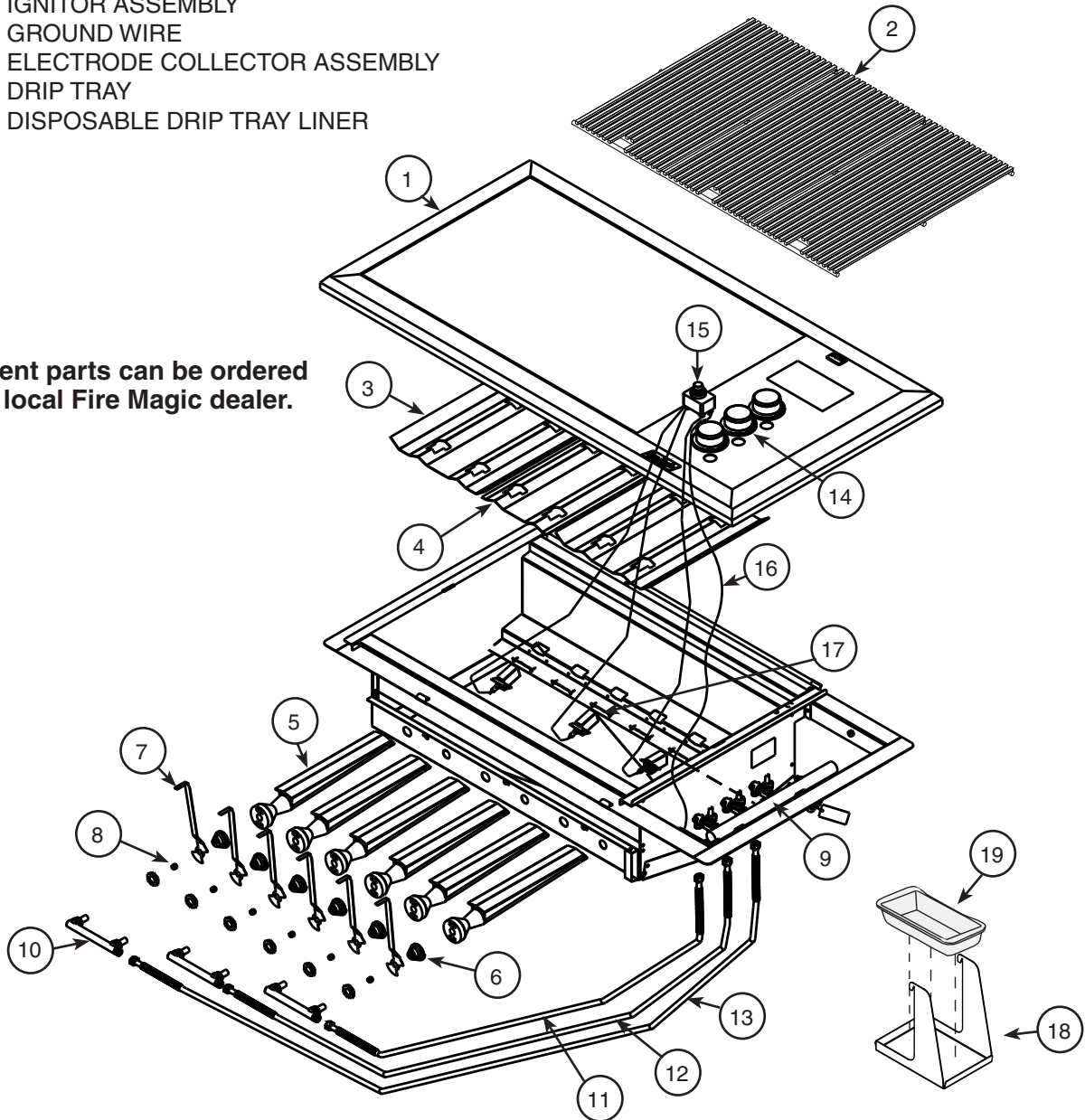

FIRE MAGIC REGAL I DROP-IN SERIES (w/ BACKBURNER) PARTS LIST

IMPORTANT

This Fire Magic oven and backburner are fully pre-assembled and tested at the factory.

DO NOT attempt to remove the oven and backburner (optional) from the barbecue prior to or during installation or damage to the connecting gas line and ignitor wiring may occur.

The plastic straps that secure the oven (optional) to the barbecue unit must be removed and discarded prior to lighting.

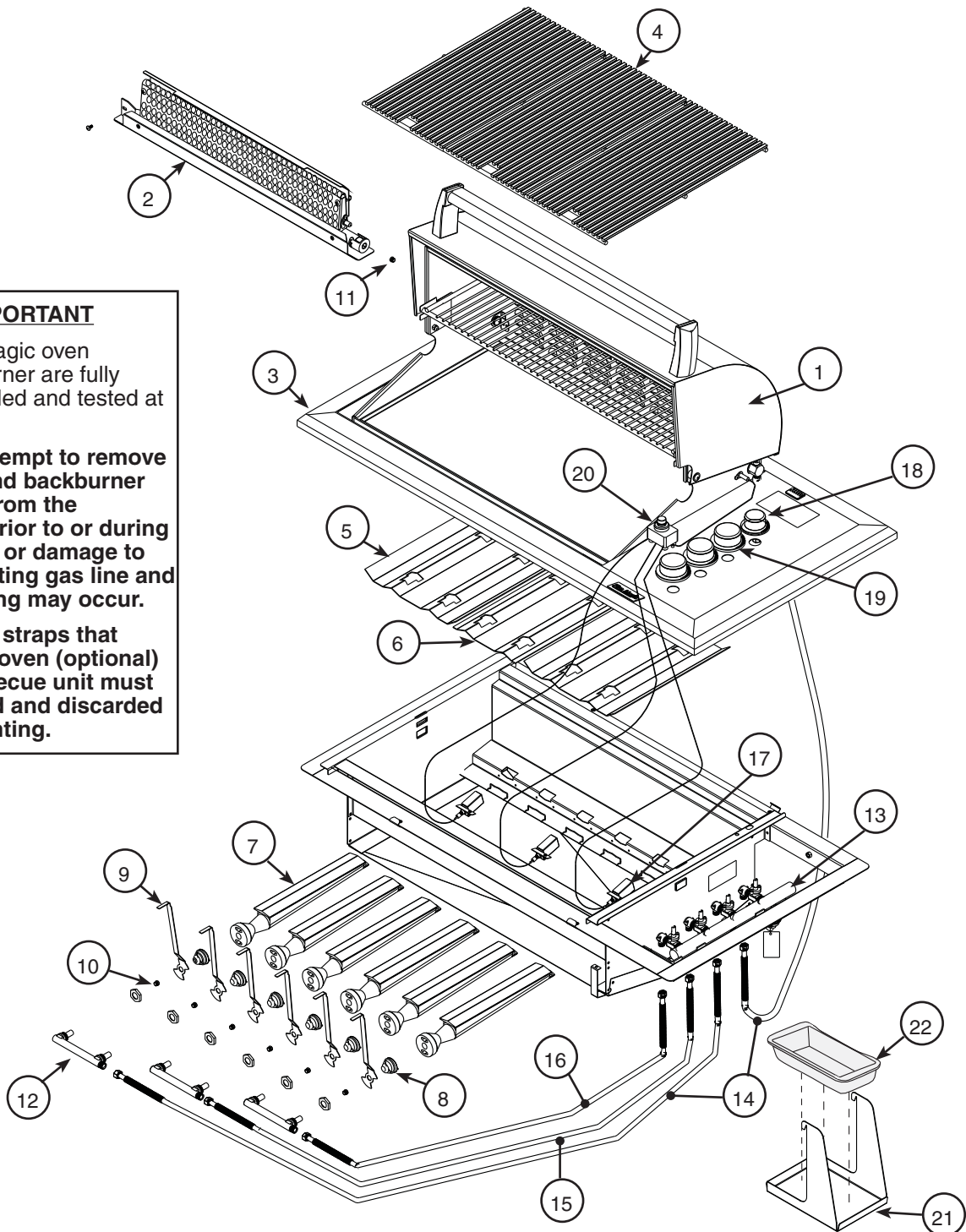

Item	Description
1.	OVEN HOOD W/ BACKBURNER (S.S. OR PORCELAIN)
2.	BACKBURNER ASSEMBLY
3.	TOP PANEL (STAINLESS STEEL) or TOP PANEL (PORCELAIN)
4.	18"x10" COOKING GRID (PORCELAINIZED CAST IRON) (3) or 18"x10" COOKING GRID (STAINLESS STEEL) (3)
5.	FLAVOR GRID 7" (1)
6.	FLAVOR GRID 10" (2)
7.	BURNER (6)
8.	AIR SHUTTER SPRING (6)
9.	AIR SHUTTER (6)
10.	ORIFICE (NAT GAS) or ORIFICE (PROPANE GAS)

Item	Description
11.	BACKBURNER ORIFICE (NAT GAS) or BACKBURNER ORIFICE (PROPANE GAS)
12.	BURNER MANIFOLD (3)
13.	VALVE MANIFOLD W/ VALVE & REGULATOR
14.	48" FLEX TUBE ASSEMBLY
15.	34" FLEX TUBE ASSEMBLY
16.	15.5" FLEX TUBE ASSEMBLY
17.	ELECTRODE COLLECTOR ASSEMBLY
18.	BACKBURNER KNOB (1)
19.	CONTROL KNOB (3)
20.	IGNITOR GENERATOR
21.	DRIP TRAY
22.	DISPOSABLE DRIP TRAY LINER

FIRE MAGIC REGAL I DROP-IN BACKBURNER & OVEN PARTS LIST (WHERE FITTED)

Important: Your Fire Magic barbecue, oven and backburner (where fitted) are fully pre-assembled and tested at the factory.

Do not attempt to remove the oven and backburner from the barbecue prior to or during installation. Damage to the connecting gas line and ignitor wiring may occur.

The plastic straps that secure the oven to the barbecue unit should be removed and discarded prior to lighting.

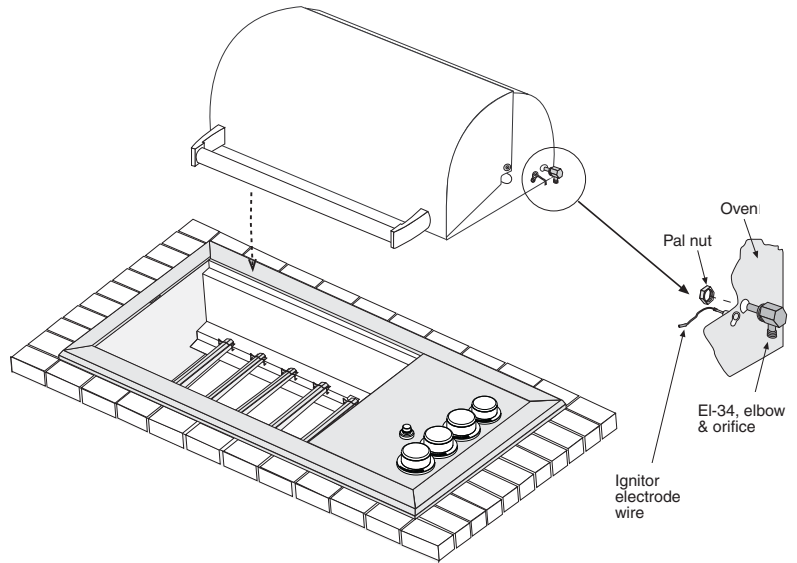

PARTS INCLUDED WITH THE BACKBURNER ASSEMBLY ARE INSIDE THE BROKEN LINE EXPLODED VIEW OF BACKBURNER ASSEMBLY

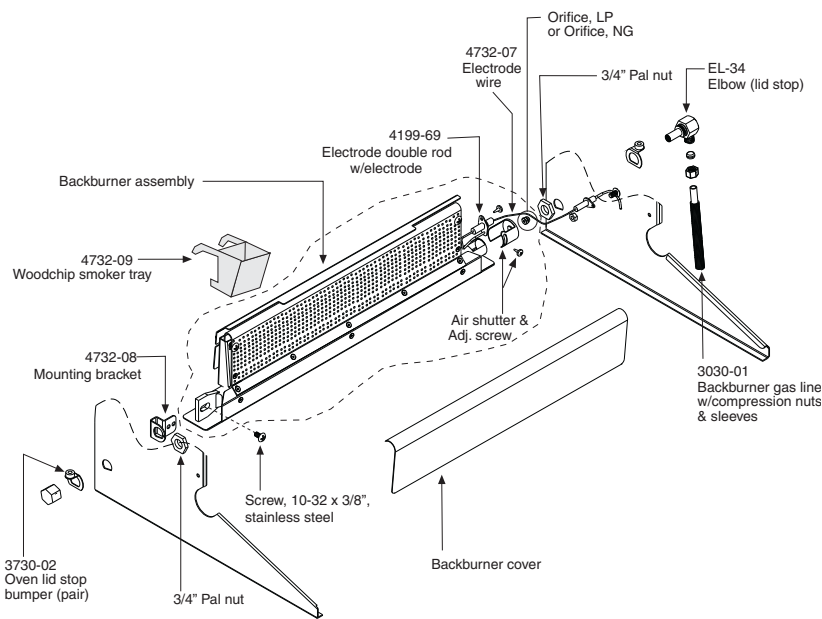

Item No.	Description
1.	Rotisserie motor with mounting bracket attached
2.	Spit prongs
3.	Handle
4.	Spit rod 5/8" hex
5.	Counterbalance
6.	Spit bracket

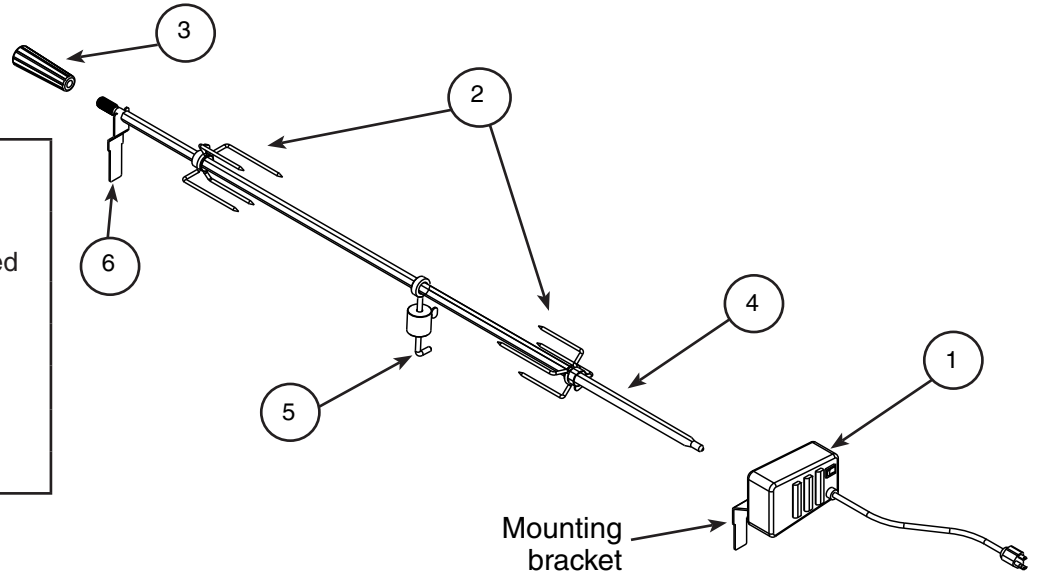

MODEL SPECIFICATIONS

MODEL SPECIFICATIONS TABLE

Table 1	
Main burner quantity per pair N/P orifice drill size	3 #52/#61
Backburner † N/P orifice drill size	#42/#54
Backburner Air Shutter † N/P	5/8" gap 7/16" gap
Optional Regal insulating liner model #	3270-50
A Countertop to unit bottom cut-out*	18"
B Side to side non-combustible cut-out*	41 1/2"
C Front to back non-combustible cut-out*	20 1/2"

* If using an insulating liner consult liner instructions for counter cut-out dimensions.

† If equipped

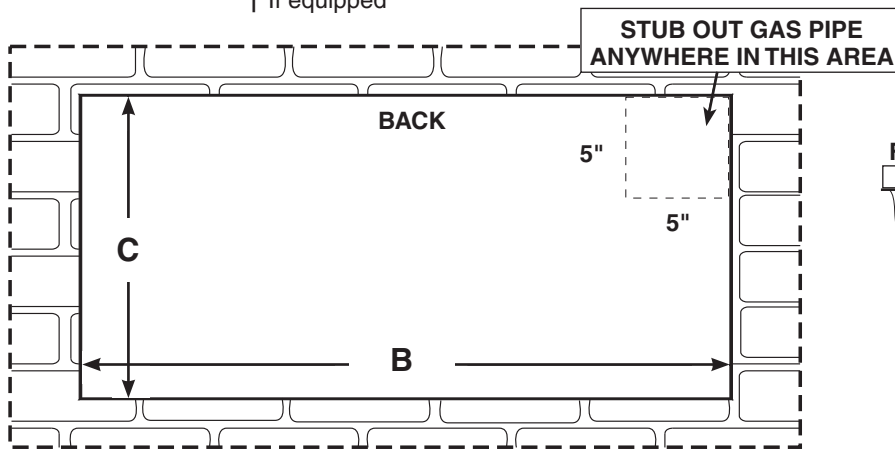

Fig. 8-1

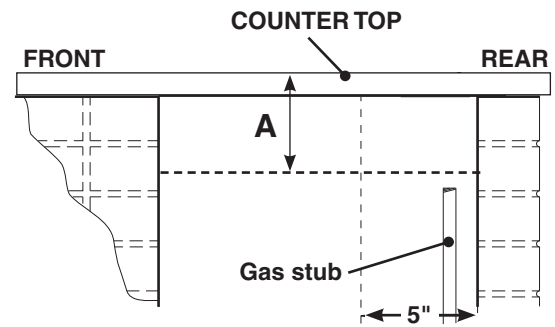

Fig. 8-2

Important: FOR YOUR SAFETY, you must provide openings in the island enclosure for drainage, replacement air, and cross-ventilation of any storage area exposed to possible leakage from gas connections, the unit, or propane bottles. See the ENCLOSURE REQUIREMENTS section for details.

An access panel/door is required to allow for ease of access to drip tray and all connections (right side of grill).

BUILT-IN GRILL DIMENSIONS TABLE

Model	Height		Width	Depth
	(Top to bottom)		(Left to right)	(Front to back)
	Hanger to top (with oven)		Hanger to hanger (F)	Maximum depth (G)
	Open (D)	Closed (E)		
Regal I	20 3/8"	15 1/4"	45"	26 1/2"

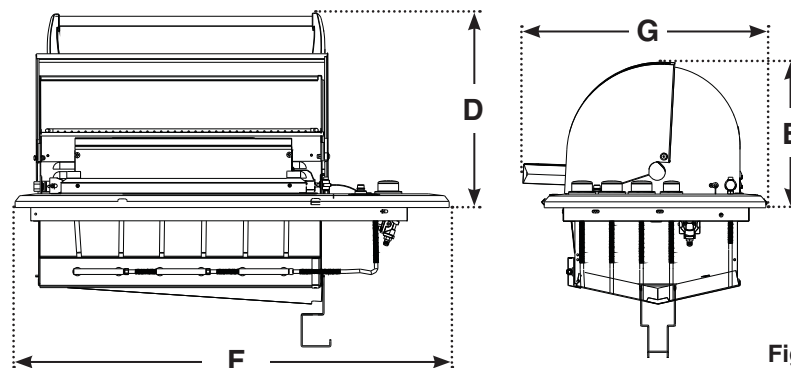

Fig. 8-3

INSTALLATION REQUIREMENTS

This grill is designed for outdoor use only. **DO NOT** use this grill inside a building, garage, enclosed area, or under an unprotected overhead combustible construction. See the EXHAUST REMOVAL section on the following page for details on installing under a patio roof. **DO NOT** use this grill in or on a recreational vehicle or boat.

Important: If installing this grill in a combustible surround, the correct R.H. Peterson insulating liner must be used.

Important: Refer to the information below to ensure all required clearances are met.

The grill must have a minimum clearance of 18" from combustible materials/items AT ALL TIMES.

For the minimum clearances between the grill and any side or rear walls, your setup must fall within one (or more) of the following:

A. Clearance between grill and strictly non-combustible wall
(i.e. brick wall, see Fig. 9-1)

- The grill must have a minimum of 4" right, left, and rear clearance from any non-combustible wall.
(To allow for proper ventilation and prevent dangerous overheating.)

B. Clearance between grill and a protected combustible wall
(i.e. a non-combustible wall in front of a combustible wall to serve as a barrier. This can be accomplished by brick, or a metal stud finished with non-combustible substrate, see Fig. 9-2)

- The grill must have a minimum of 14" right, left, and rear clearance from the protected combustible wall.
(The 4" non-combustible material plus an additional 10" clearance between the grill and protected wall.)

C. Clearance between grill and combustible wall

- The grill must have a minimum of 18" right, left, and rear clearance from any combustible wall (see Fig. 9-3).

Backsplash (if applicable)

If a non-combustible backsplash exists, it must have a minimum of a 4" clearance from the rear of the grill (to allow for proper ventilation and prevent dangerous overheating). See Fig. 9-4.

Important: This 4" backsplash clearance must first be met prior to any non-combustible walls beginning behind it.

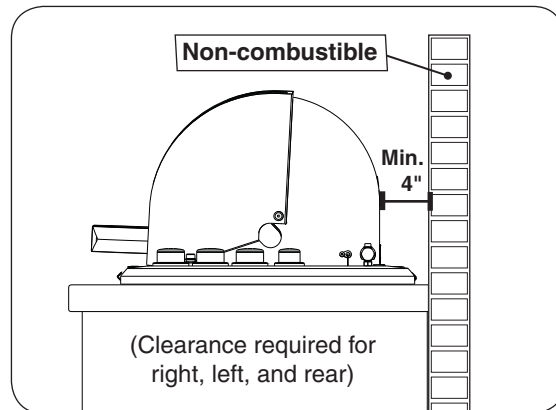

Fig. 9-1 Clearance 'A' Diagram

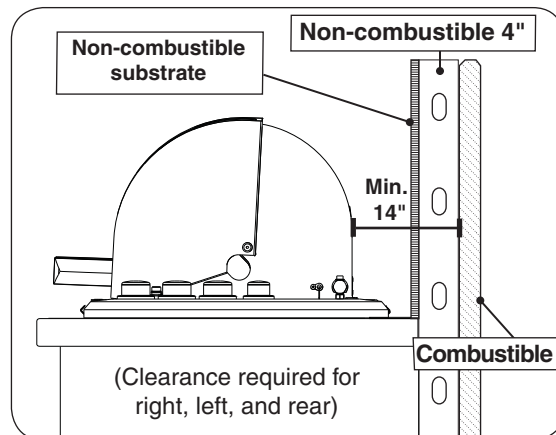

Fig. 9-2 Clearance 'B' Diagram

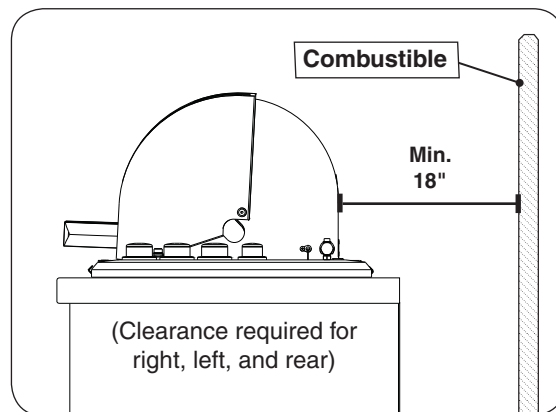

Fig. 9-3 Clearance 'C' Diagram

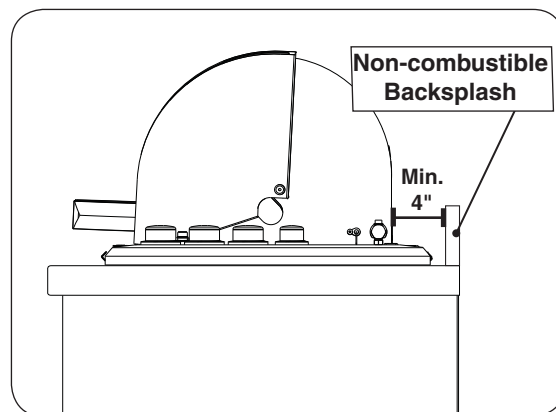

Fig. 9-4 Backsplash clearance

INSTALLATION REQUIREMENTS (CONT.)

This is a drop-in type unit designed to fit into countertop enclosures. The top panel of the unit is removable for gas hookup, servicing and burner adjustment.

The top panel **MUST** remain removable for servicing (see PARTS LIST).

Note: This unit should be installed so that it can be removed at a later date if factory service is required. Any protrusion into the barbecue enclosure may obstruct the frame and prevent the unit from dropping into place (see GAS SUPPLY PLUMBING REQUIREMENTS).

ENSURING PROPER COMBUSTION AIR AND COOLING AIRFLOW

Proper airflow (Fig. 10-1) **MUST** be maintained for the grill to perform as it was designed. If airflow is blocked, overheating and poor combustion will result. Do not block the air inlet around the inside edges of the top panel or more than 75% of the cooking grid surface with pans or griddles.

EXHAUST REMOVAL

If installed or used under a patio roof, the cooking grid area must be fully covered by an exhaust hood with a vent. An exhaust fan with a rating of 1,000 CFM (cubic feet per minute) or more may be necessary to effectively remove smoke and other cooking by-products from the area under the hood. **Fire Magic Vent Hoods are available to meet this requirement.** This grill must not be used under unprotected overhead combustible construction. **THIS UNIT MUST NOT BE LOCATED IN A FULLY ENCLOSED AREA OF ANY KIND.**

GAS-SUPPLY PLUMBING REQUIREMENTS

For natural gas or a household propane system, rigid $\frac{1}{2}$ " or $\frac{3}{4}$ " black steel pipe or local code-approved pipe is required to conduct the gas supply to the unit. Contact your local gas supplier. Connect this pipe to a required C.S.A.-approved stainless-steel flex connector. **DO NOT use a rubber hose within the grill enclosure.** Apply only joint compounds that are resistant to all gasses to all male pipe fittings except flare fittings. Make sure to tighten every joint securely.

The gas supply pipe should enter from the floor, or from the back or side wall in the right rear corner of the barbecue enclosure, behind the valve control zone. This pipe should terminate with a $\frac{1}{2}$ " male pipe thread, situated within 12" of the countertop and no more than 5" from the back and side walls. See the MODEL SPECIFICATIONS section for details.

Note: If $\frac{1}{2}$ " pipe is used with **natural gas**, it should be no longer than 20'.

Important: An external valve (with a removable key) in the gas line is necessary for safety when the grill is not in use. It also provides for convenient maintenance.

GAS SUPPLY AND MANIFOLD PRESSURES:

For **natural gas** - normal 7" (17.78 cm) water column (w.c.), minimum 5" (12.7 cm), maximum 10 $\frac{1}{2}$ " (26.7 cm). For **propane gas** - normal 11" w.c., minimum 10" (25.4 cm), maximum 13" (33 cm).

CAUTION: Wind blowing into or across the rear oven lid vent (if applicable) can cause poor performance and/or dangerous overheating. Orient the grill so that the prevailing wind blows toward the front of the grill.

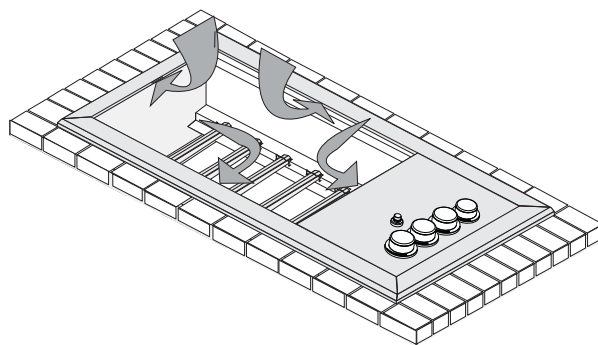

Fig. 10-1 - Ventilation Diagram

ENCLOSURE REQUIREMENTS

FOR YOUR SAFETY, you must provide the openings listed below for drainage, replacement air, and cross-ventilation of any storage area exposed to possible leakage from gas connections, the unit, or propane cylinders.

One side of the enclosure can be left completely open to the outside, OR 4 ventilation openings must be created:

NATURAL GAS INSTALLS

Two of the openings are to be at the top level (approx. 4" below the countertop) and on opposite walls of the enclosure. 2 more openings must be at the floor level (no more than 5" above the floor) and on opposite sides of the enclosure. Each opening must have a minimum of 10 sq. in. of free area. To achieve the proper ventilation, you may drill a series of holes, omit the grout from masonry joints, or replace a brick with a hardware cloth screen. If the floor in the cabinet is raised and the space beneath the cabinet is open to the outside, the lower ventilation openings may be in the floor. Reference Fig. 11-1.

PROPANE GAS INSTALLS (HOUSEHOLD & CYLINDER)

Two of the openings are to be at the cylinder valve level (approx. 16" above the floor) and on opposite walls of the enclosure. 2 more openings must be at the floor level (no more than 5" above the floor) and on opposite sides of the enclosure. Each opening must have a minimum of 10 sq. in. of free area. To achieve the proper ventilation, you may drill a series of holes, omit the grout from masonry joints, or replace a brick with a hardware cloth screen. If the floor in the cabinet is raised and the space beneath the cabinet is open to the outside, the lower ventilation openings may be in the floor. Reference Fig. 11-1.

WHEN A PROPANE CYLINDER IS USED

When a propane cylinder is installed inside of the enclosure, the guidelines below **MUST** be followed. **FAILURE TO DO SO MAY CAUSE DAMAGE TO YOUR UNIT AND/OR PERSONAL INJURY.** Reference Fig. 11-2 for an example.

- Only a C.S.A. listed stainless steel connector can be connected to the grill.
- The regulator/hose assembly coming from the propane cylinder can only be connected to the above mentioned grill flex connector. **DO NOT connect the regulator/hose assembly directly to the grill.** An adapter will be required.
- A heatshield must be installed to protect the regulator/hose assembly and propane cylinder valve.
- **Fire Magic offers a propane cylinder door with tank tray to meet the cylinder install requirements. See Fig. 11-3.**

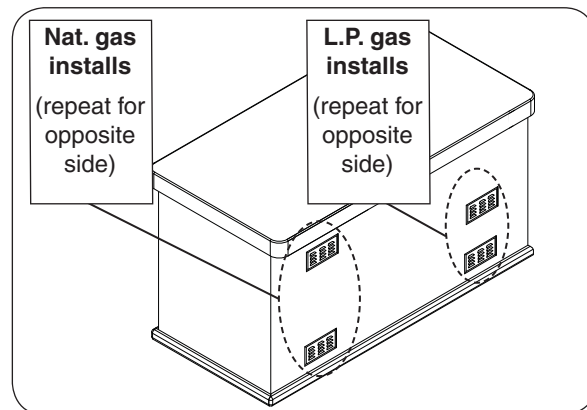

Fig. 11-1 Ventilation detail

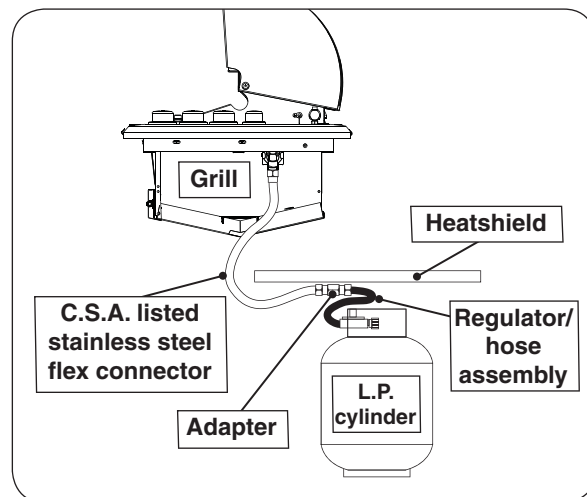

Fig. 11-2 Propane cylinder orientation

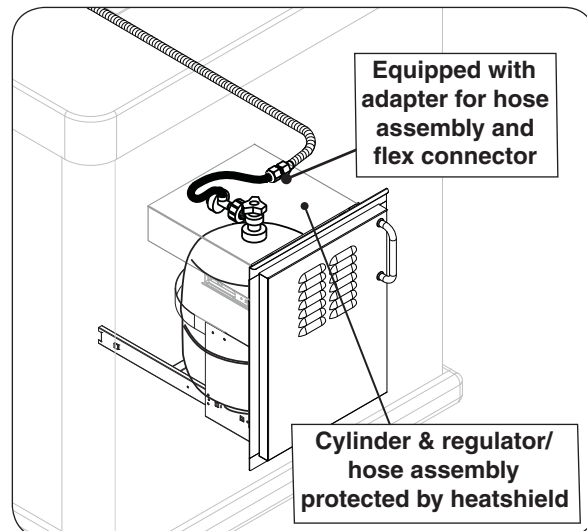

Fig. 11-3 Optional Fire Magic door w/ tank tray

UTILISATION SÛRE ET ENTRETIEN DES CYLINDRES DE GAZ DE PROPANE

IMPORTANT POUR VOTRE SÛRETÉ

LISEZ ET SUIVEZ TOUS LES AVERTISSEMENTS ÉQUIPÉS DE VOTRE CYLINDRE DE GAZ DE PROPANE.

En actionnant cet appareil avec un cylindre de gaz de propane ON DOIT observer ces instructions et avertissements.

LE MANQUE DE FAIRE AINSI PEUT AVOIR COMME CONSÉQUENCE UNE INCENDIE OU UNE EXPLOSION SÉRIEUSE.

CYLINDRE ET CONDITIONS ET

CARACTÉRISTIQUES DE CONNECTEUR

- Des cylindres et les valves de gaz de propane doivent être maintenus en bon état et doivent être remplacés s'il y a des dommages évidents au cylindre ou à la valve.
- Ce gril, une fois utilisé avec un cylindre, devrait être relié à un gallon de la norme 5 (20lb.) cylindre de gaz de propane équipé d'un OPD (remplissez au-dessus du niveau le dispositif d'empêchement). L'OPD a été exigé sur tous les cylindres vendus depuis octobre 1.1998 pour empêcher le remplissage excessif.
- Les dimensions de cylindre devraient être approximativement 12" (30.5cm) de diamètre et 18" (45.7cm) hauts. Des cylindres doivent être construits et marqués selon les caractéristiques pour des cylindres de gaz de propane du département des ETATS-UNIS du transport (D.O.T.) ou le niveau national du Canada, du CAN/CSA-B339, des cylindres, des sphères et des tubes pour le transport des marchandises dangereuses.
- Le cylindre doit inclure un collier pour protéger la valve de cylindre et le circuit d'alimentation de cylindre doit être assuré le retrait de vapeur.
- Le régulateur de pression et l'ensemble de tuyau utilisé doivent assortir les spécifications pour le type I par ANSI Z 21.58/CGA 1.6 (voir la figue. 12-1).
- La valve de cylindre de gaz de propane doit être équipée d'un dispositif d'accouplement de raccordement de cylindre, décrit comme type I dans la norme définie dans le e. de paragraphe ci-dessus. Ce dispositif est généralement décrit comme coupleur rapide de fil de point culminant.
- Si votre cylindre de gaz de propane vient avec une prise de la poussière, placez le bouchon anti-poussière sur la sortie de valve de cylindre toutes les fois que le cylindre n'est pas en service.

OPÉRATION DE COUPLEUR RAPIDE

Pour relier le régulateur/hose à l'ajustage de précision de valve de cylindre de gaz de propane: Serrez l'écrou de main sur le régulateur au-dessus de l'ajustage de précision de fil de point culminant sur la valve de cylindre. Tournez l'écrou de

main dans le sens des aiguilles d'une montre pour engager les fils et pour serrer jusqu'à ce que douillettement. L'utilisation des pinces ou de la clé ne devrait pas être nécessaire. Seulement le propane marqué par cylindres doit être employé.

Pour débrancher: Tournez l'écrou de main dans le sens contraire des aiguilles d'une montre jusqu'à isolé (fig. 12-1).

Important: Avant d'employer le gril, et ensuite chaque fois que le cylindre est enlevé et rattaché, examinez tous les raccordements pour déceler les fuites. Arrêtez les valves de gril et ouvrez la valve principale de cylindre, puis vérifiez les raccordements avec de l'eau savonneux. Réparez toutes les fuites avant d'allumer le gril.

ATTENTION: Tournez toujours la valve principale de cylindre de propane au loin après chaque utilisation, et avant de déplacer le gril et le cylindre, ou débrancher l'accouplement. Cette valve doit rester fermée et le cylindre a débranché alors que l'appareil n'est pas en service, quoique l'écoulement de gaz soit arrêté par un dispositif de sûreté quand le coupleur est débranché.

Inspectez soigneusement l'ensemble de tuyau chaque fois avant que le gaz soit allumé. Un tuyau fissuré ou effiloché doit être immédiatement remplacé.

Si l'appareil est stocké à l'intérieur, le cylindre doit être disconnected et a enlevé. Des cylindres Disconnected doivent être stockés dehors, hors de la portée des enfants, avec les prises de valve filettées étroitement installées, et ne doivent pas être stockés dans un bâtiment, le garage, ou n'importe quel autre secteur inclus.

POUR VOTRE SÛRETÉ

- Ne stockez pas un cylindre de gaz disponible de propane dessous ou ne vous approchez pas de cet appareil.
- Ne remplissez jamais cylindre au delà de 80 pour cent de plein.
- SI L'INFORMATION DANS "A" ET "B" N'EST PAS SUIVIE EXACTEMENT, UN FEU CAUSANT LA MORT OU DES DOMMAGES SÉRIEUX PEUT SE PRODUIRE.

Fig. 12-1 type coupleur rapide de fil de point culminant d'I

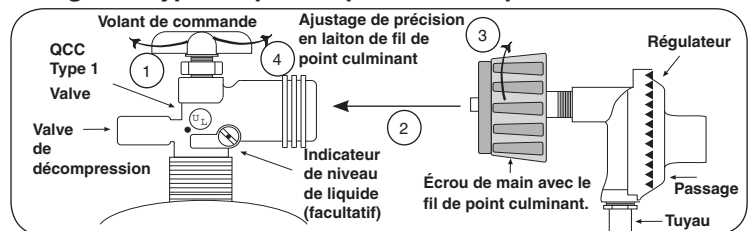

Pour la ventilation de propane, voir la section sur les exigences de boîtier.

SAFE USE & MAINTENANCE OF PROPANE GAS CYLINDERS

IMPORTANT FOR YOUR SAFETY

READ AND FOLLOW ALL WARNINGS PROVIDED WITH THE PROPANE-GAS CYLINDER.

When operating this appliance with a propane-gas cylinder, these instructions and warnings **MUST** be observed.

FAILURE TO DO SO MAY RESULT IN A SERIOUS FIRE OR EXPLOSION.

CYLINDER/CONNECTOR REQUIREMENTS

- a. Propane-gas cylinders, valves, and hoses must be maintained in good condition and must be replaced if there is visible damage to either the cylinder or valve. If the hose is cut or shows excessive abrasion or wear, it must be replaced before using the gas appliance (see e.).
- b. This unit, when used with a cylinder, should be connected to a standard 5-gallon (20 lb.) propane-gas cylinder equipped with an OPD (Overfill Prevention Device). The OPD has been required on all cylinders sold since October 1, 1998, to prevent overfilling.
- c. Cylinder dimensions should be approximately 12" (30.5 cm) in diameter and 18" (45.7 cm) high. Cylinders must be constructed and marked in accordance with the *Specifications for Propane Gas Cylinders of the U.S. Department of Transportation (D.O.T.)* or the National Standard of Canada, *CAN/CSA-B339, Cylinders, Spheres, and Tubes for Transportation of Dangerous Goods*.
- d. The cylinder used must include a collar to protect the cylinder valve, and the cylinder supply system must be arranged for vapor withdrawal.
- e. The pressure regulator and hose assembly used must match the specification for Type I by *ANSI Z 21.58/CGA 1.6* (see Fig. 13-1).
- f. The propane-gas cylinder valve must be equipped with a cylinder connection coupling device, described as Type I in the standard defined in paragraph e. above. This device is commonly described as an Acme thread quick coupler.
- g. If the propane-gas cylinder comes with a dust plug, place the dust cap on the cylinder valve outlet whenever the cylinder is not in use.

QUICK COUPLER OPERATION

To connect the regulator/hose assembly to the propane-gas cylinder valve fitting: Press the hand nut on the regulator over the Acme thread fitting on the cylinder valve. Turn the hand nut clockwise to engage the threads and tighten until snug.

The use of pliers or a wrench should not be necessary. Only cylinders marked "propane" may be used.

To disconnect: Turn the hand nut counterclockwise until detached (Fig. 13-1).

Important: Before using the unit, and after each time the cylinder is removed and reattached, check the hose for wear (see a.) and check all connections for leaks. Turn off the unit valves and open the main cylinder valve, then check connections with soapy water. Repair any leaks before lighting the unit.

CAUTION: Always turn the propane cylinder main valve off after each use, and before moving the unit and cylinder or disconnecting the coupling. This valve must remain closed and the cylinder disconnected while the appliance is not in use, even though the gas flow is stopped by a safety feature when the coupler is disconnected.

Carefully inspect the hose assembly each time before the gas is turned on. A cracked or frayed hose must be replaced immediately.

If the appliance is stored indoors, the cylinder must be disconnected and removed. Disconnected cylinders must be stored outdoors, out of the reach of children, with threaded valve plugs tightly installed, and must not be stored in a building, garage, or any other enclosed area.

FOR YOUR SAFETY

- a. DO NOT store a spare propane-gas cylinder under or near this appliance.
- b. NEVER fill the cylinder beyond 80-percent full.
- c. IF THE INFORMATION IN a. AND b. IS NOT FOLLOWED EXACTLY, A FIRE CAUSING DEATH OR SERIOUS INJURY MAY OCCUR.

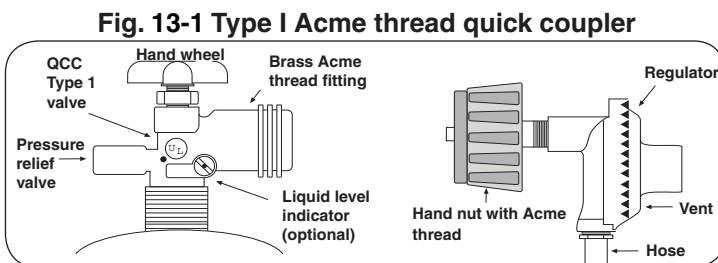

For propane ventilation requirements, see the ENCLOSURE REQUIREMENTS section.

INSTALLATION

CONNECT THE GAS SUPPLY

For propane cylinders:

For connecting a propane unit to a portable propane tank, read the safety warnings and follow the instructions in the section SAFE USE AND MAINTENANCE OF PROPANE GAS CYLINDERS.

Note: When a propane cylinder is installed inside of the enclosure, the guidelines found in the ENCLOSURE REQUIREMENTS section MUST be followed.

For household propane or natural gas units:

CAUTION: Use only C.S.A. listed stainless-steel flex connectors within the enclosure.

WARNING

A rubber or plastic connector will rupture or leak, resulting in an explosion or serious injury if used inside the appliance enclosure.

Installation can be completed by accessing the unit through the access panel on the right side of your enclosure. Alternatively, the top panel may be removed (see CHECKING/CONVERTING THE BURNER ORIFICES section).

1. Make sure that your gas supply is turned **OFF**. Then connect the stainless steel flex connector to the gas supply stub. Use pipe joint compound that is resistant to all gasses on the male pipe fitting and tighten securely. Do not use pipe joint compound to connect flare fittings.
2. If you have not already done so, lower your barbecue into place, making sure not to pinch or kink the gas connector.
3. Bring the flex connector up to the regulator found on the right side of the unit.
4. Connect the flex connector to the adapter on the regulator. Support the regulator adapter with a wrench to avoid applying excessive torque to the assembly while tightening this connection securely. Do not use pipe compound on the flare fitting.
5. Make sure the barbecue burner valves are in the **OFF** position. Turn the gas supply on. Then carefully check all gas connections for leaks with a brush and soapy water before lighting. **NEVER USE A MATCH OR OPEN FLAME TO TEST FOR LEAKS.**
6. Place a disposable liner in the provided drip tray. Hook the drip tray onto the two slots found on the right side of the grill.

Note: Disposable liners (mini-loaf pans) are available at many stores. For your convenience, the drip pan holder is designed so an empty 14 to 18 ounce (.41 lt to .53 lt) tin can may be substituted for the drip pan and drip pan support.

7. Screw the two 1 1/4" (2.8 cm) stabilizer screws (packed with the instructions) into the threaded inserts in the right rear corner of the frame assembly. This will secure your barbecue in place.
8. If removed, replace the top panel. Be sure to reattach the ignitor wires. The top panel may be adjusted left to right for bezel alignment with gas valve knobs.
9. If removed, replace the burner control knobs.

CHECKING AND CONVERTING GAS TYPE

This unit comes from the factory configured for one type of gas, as marked on the label located behind the control panel, or on the interior of the unit's enclosure.

A certified kit is available from the manufacturer to convert your appliance from natural gas to L.P. or vice versa. Contact your dealer for ordering information. The professional installer must reference the steps below for conversion information. If the conversion kit ordered includes instructions, follow those instructions.

1. Change brass gas orifices (included at original shipping) on each burner to match the new gas type (see MODEL SPECIFICATIONS TABLE, Table 1).
2. Switch the convertible gas regulator to match the new gas type (see section below).
3. Plumb the unit as appropriate for the new gas supply.
4. Apply the label for the new gas (included at original shipping) over the old gas information found on your unit.

WARNING

HAZARDOUS OVERHEATING WILL OCCUR IF A NATURAL-GAS ORIFICE IS USED WITH PROPANE GAS. IF YOU ARE NOT SURE IF THE CORRECT ORIFICES ARE INSTALLED, OR IF AN ORIFICE CHANGE IS NECESSARY, REFER TO THE FOLLOWING INSTRUCTIONS.

CAUTION: Make sure the unit is at a safe temperature and isolated from gas and electrical supplies before beginning the tasks outlined below.

Note: The cooler the unit, the greater the tolerances between the stainless-steel parts, and therefore the easier to disassemble and reassemble parts of the unit.

CAUTION: For your safety, exercise caution and use adequate hand protection (such as gloves) when handling potentially sharp sheet-metal parts.

CHECKING AND CONVERTING THE REGULATOR

Regulator: note cap on top

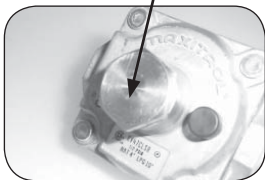

Note: Each end of the plastic converter is engraved with either the letters "NAT" or "L.P." (propane) for the respective gasses. When the converter is in the cap and the cap is held uppermost, the letters seen indicate the gas that the regulator is set up for.

To convert the regulator from one gas to another, follow steps 1-4.



STEP 1: Unscrew and remove the cap from the regulator, extracting the converter.



STEP 3: Turn the converter around and replace it carefully, into the center of the cap (it will snap into place). Check that you can read the type of gas the unit is set for.



STEP 2: Remove the converter (the plastic stalk) by carefully pulling it away from the center of the cap (it will snap out of its seating).

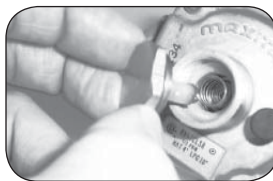

STEP 4: Replace the unit into the regulator and screw down until snug.

WARNING

THIS APPLIANCE REGULATOR IS RATED FOR 1/2 PSI MAXIMUM. IF YOUR GAS SUPPLY IS GREATER THAN 1/2 PSI, AN ADDITIONAL REGULATOR MUST BE INSTALLED TO REDUCE THE INPUT PRESSURE TO THE UNIT TO 1/2 PSI OR LESS. SEE GAS-SUPPLY REQUIREMENTS SECTION FOR PROPER GAS-SUPPLY PRESSURE.

CHECKING/CONVERTING THE BURNER ORIFICES

CHECK FUEL ORIFICES FOR PROPER SIZE

1. Your Regal I barbecue is equipped with fuel orifices for natural gas, unless otherwise indicated. To use with propane gas, you must install smaller orifices to avoid hazardous overheating. Refer to the MODEL SPECIFICATIONS TABLE for the proper orifice size needed.
2. Remove the cooking grids and flavor grids from your barbecue.
3. If the gas supply has been connected, make sure the burner valves are in the **OFF** position. Then carefully pull the valve knobs from their stems.

Note: Carefully, but firmly, lift the top panel away from the frame. The spark generator for the ignition system is attached to the top panel. The igniter need not be detached, but the wires must be unplugged from the generator before the panel is removed.

4. Using a flat blade screwdriver, pry the burner retaining clip from rear wall of the barbecue frame (see Fig.16-1). Remove the burner by; A) Pulling it to the front of the barbecue; B) Lift the far end out of the notch; C) Pull the burner away from the manifold, taking care not to lose the air shutter and spring, which may become detached when the burner is removed.

5. Using 3/8" socket, remove the orifice from the orifice holder on the burner manifold and check the number stamped on the face. Repeat for each burner as necessary.

Note: If you have the optional backburner, check the backburner orifice for size.

Note: The air shutter must be re-adjusted after removing the burner to ensure proper combustion (see the AIR SHUTTER ADJUSTMENT section).

6. Install the air shutter spring and the air shutter over the orifice holder fitting in the order and position shown in Fig. 16-1. Carefully place the burner(s) back in position, resting on the back flange of the inner liner so that the brass orifice and orifice holder fittings project well into the burners.

7. Replace all the burner hold down clips.

8. If you removed the top plate re-install the ignition wires. Your barbecue may have either two (2) or four (4) wires depending on the exact model. Pull the drip tray out. Lean the face forward and plug the wires into the terminals on the spark generator (Fig. 16-2). The wires can be plugged into any terminal.

Important: Test the electrodes for spark before securing the face to the frame (see also the section REPLACING THE IGNITOR BATTERY).

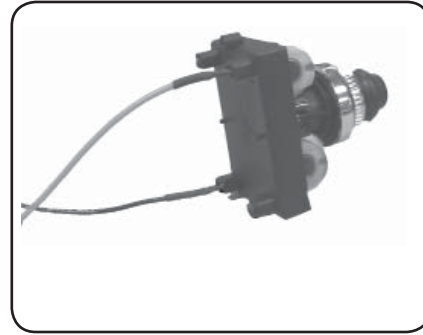

Fig. 16-2 Spark generator

9. Replace the face on the frame so the front lip of the face covers the lip on the frame. Re-secure the face with the face fastener screws.

10. Replace the control knobs.

11. Replace the flavor grids and then the cooking grids so that the cutout section of the grid is in front.

Important The oven and backburner (where fitted) are pre-installed at the factory and should not be removed from the barbecue during installation.

BACKBURNER ORIFICE SIZE CHECKING/CONVERSION

Before beginning, make sure you have the proper tools for the task.

This task requires:

- a #2 Phillips-head screwdriver
- a #2 flat-head screwdriver
- a 3/8" wrench or socket screwdriver

Note: It may be necessary to remove the rotisserie rod before beginning this procedure.

1. Remove the warming rack, if installed, and set it aside.
2. Remove the backburner cover, if installed.
3. Unscrew both backburner face plate screws using a Phillips-head screwdriver and set them aside.
4. Remove the backburner face plate by pulling the bottom toward the front of the barbecue and rotating it upward and outward until the two top tabs can be removed from the back wall of the barbecue. Set it aside.
5. Remove the backburner assembly anchoring screw on the lower left of the backburner using a Phillips-head screwdriver and set it aside.

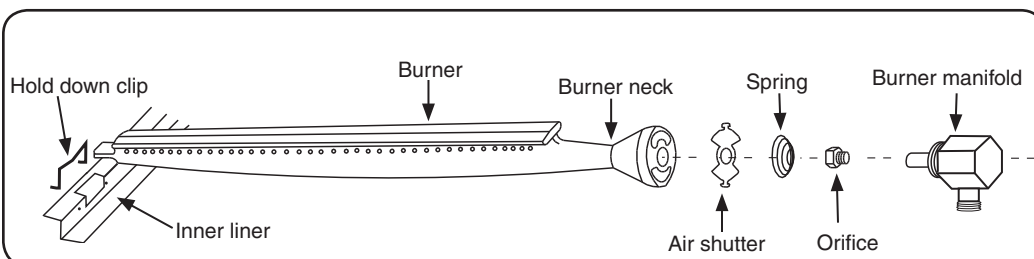

Fig. 16-1 - Burner orifice diagram

Continued on next page

CHECKING/CONVERTING THE BURNER ORIFICES (Cont.)

- Pull the backburner assembly to the left, clear of the orifice, and then rotate the top forward and downward and lay it face down across the main burner dividers.

CAUTION: Be careful not to damage the wires connected to the backburner assembly.

- Use the socket driver to remove the exposed orifice and replace it with the correct orifice for the gas to be burned (see the MODEL SPECIFICATIONS TABLE for correct orifice sizes, based on burner type and gas type).
- Replace the backburner assembly and re-insert the anchoring screw. Center the backburner assembly so that the backburner face plate will fit over it. Tighten the anchoring screw using a Phillips-head screwdriver.
- While the backburner faceplate is still off, adjust the backburner air shutter opening size by loosening the air shutter adjustment screw with a flat-head screwdriver and sliding the air shutter to the position indicated in the MODEL SPECIFICATIONS TABLE; then re-tighten the adjustment screw. (see section on AIR SHUTTER ADJUSTMENT).
- Replace the backburner face plate by first inserting the upper tabs into the slots in the back wall of the barbecue and then rotating the bottom downward and inward.
- Replace the two backburner faceplate screws using a Phillips-head screwdriver.

Tip: Re-attaching the backburner faceplate may be easier if the left screw is replaced before the right screw.

THE BACKBURNER COVER

The backburner cover is installed by placing the curved part of the cover over the top of the perforated portion of the backburner (see Fig. 17-2). The cover should be kept in place on the backburner when it is not in use. This will keep your backburner free from grease splatter and debris that may hinder its performance.

Important: You must remove the backburner cover before lighting the backburner.

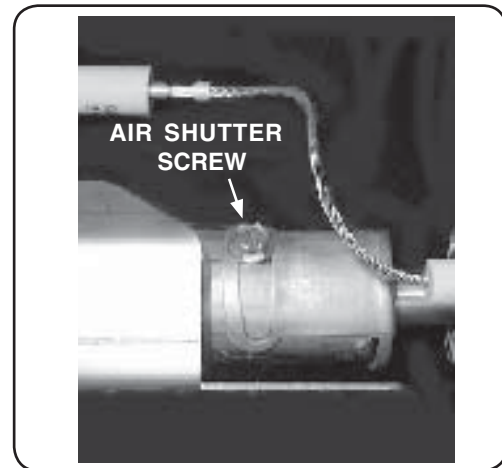

Fig. 17-1

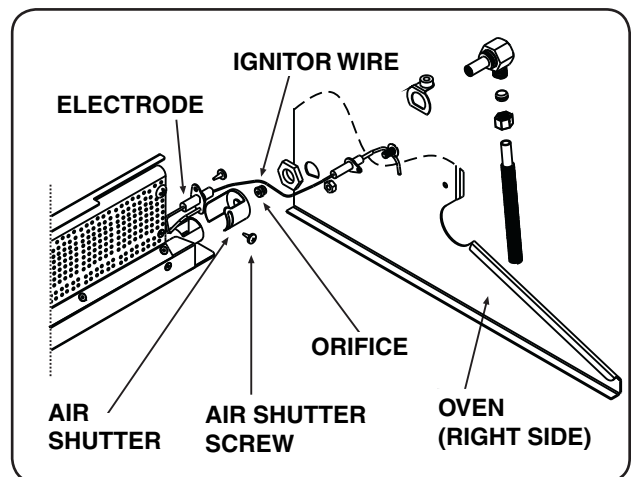

Fig. 17-2

AIR SHUTTER ADJUSTMENT

MAIN BURNER AIR SHUTTER ADJUSTMENT

Important: The air shutters must be adjusted after installation. If not, this appliance may not light, heat evenly, or cook properly.

Main burner air shutters are easily accessed by removing (when cool) the top panel (face). The air shutters are controlled by the wire levers at the front of the burners (see PARTS LIST). The air shutter has a small dimple (see Fig. 18-1) that allows it to lock into notches in the burner face. This prevents the air shutter from moving.

WARNING

ONLY ADJUST 2 AIR SHUTTERS AND THEIR CORRESPONDING BURNERS AT ONE TIME. SHUT OFF THE BURNERS PRIOR TO MOVING ON TO THE NEXT SET.

1. **Using the wire levers**, close the air shutters by turning the tabs to a vertical position (Fig. 18-2).
2. Light the corresponding burner pair in accordance with the LIGHTING INSTRUCTIONS and burn for two minutes with the knob on **HI LIGHT** and the oven open.
3. After burning for two minutes, open the air shutters **using the wire levers** until the flames lift off, or appear not to be touching the burners (Fig. 18-1).
4. Begin closing the air shutters **with the wire levers** until the flames appear to burn while touching the burner ports (Fig. 18-2).

Note: You may then see short yellow tips on the flames. If flames are a lazy yellow, open the air shutters until the flame is blue with yellow tipping.

Note: Barbecues, in some installations, achieve a better air/gas mixture and will ignite more quickly if the valve is first turned beyond **HI LIGHT** to **LOW** for lighting.

5. Shut off the burners, then repeat for the next set.

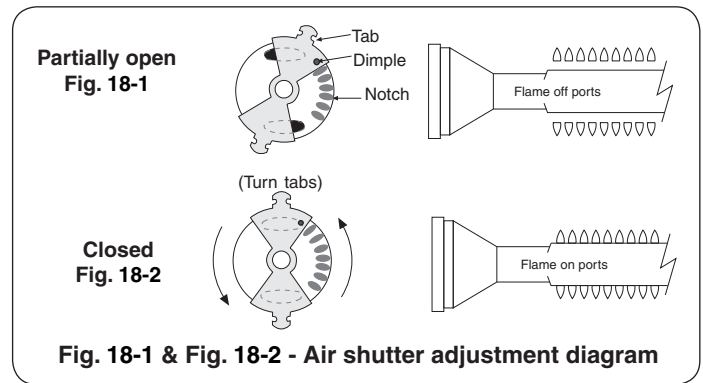

Fig. 18-1 & Fig. 18-2 - Air shutter adjustment diagram

BACKBURNER AIR SHUTTER ADJUSTMENT

Important: It is normal for the backburner to smoke when it is burned for the first time. Burning your backburner on **HI LIGHT** for approximately 15 minutes will eliminate the smoking.

- a. The air shutter on your backburner is preset at the factory. However, due to atmospheric conditions and different gas pressures, it may be necessary to adjust the air shutter to obtain a proper burn.
- b. First remove the backburner cover (if installed), then loosen the air shutter screw (see Fig. 18-3). It may be necessary to use pliers to turn the air shutter. Light the backburner. With the control knob on **HI LIGHT** adjust the air shutter to have a blue flame that is not lifting off the burner (it may also have slightly yellow tips).
- c. Tighten the air shutter adjustment screw.

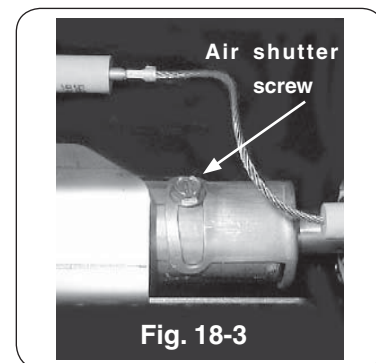

Fig. 18-3

BARBECUE SAFETY INFORMATION & MAINTENANCE

Each time you use the barbecue, make sure that:

1. The area around the barbecue is clear of flammable vapors, liquids, and substances such as gasoline, yard debris, wood, etc.
2. There is no blockage of the airflow through the vent space located below the face of the unit.
3. When using propane gas:
 - a. The special ventilation openings in the enclosure should be kept free and clear of debris (see **PLANNING THE LOCATION OF THE BARBECUE**).
 - b. If connected to a propane cylinder, the rubber hose attached to the regulator should be carefully inspected before each use.
 - c. The propane cylinder, regulator, and rubber hose should be installed in a location not subject to heating above 125° F (51° C).
4. The burner flames burn evenly along both sides of each burner with a steady flame, which is mostly blue. (Refer to section on **AIR SHUTTER ADJUSTMENT**.) A proper flame pattern will ensure safe operation and optimal performance. Adjust the air shutter as needed. If burner flames are not normal, check the orifice and burner for insects or insect nests.
5. The inline gas valve or gas cylinder valve is always shut **OFF** when the barbecue is not in use.
6. The drip collector hole is clear and unobstructed. Excessive grease deposits can result in a grease fire.
7. The barbecue is free and clear from combustible materials, gasoline, and other flammable vapors and liquids.

DRIP COLLECTION SYSTEM

The drip collector in this barbecue is part of the unit's main frame and is located below the burners. The drip collector has slots that will allow excess drippings to fall through during cooking, while separating the firebox from the drip tray. Clean the drip tray after each use.

The drip collector allows you to brush or scrape residue from the barbecue's inner liner into the drip tray. Following the manufacturer's instructions and regular cleaning of the barbecue's interior with oven cleaner, will help to prevent grease fires.

Periodically check the burners to make sure they are clear of debris. Properly adjusted burner flames burn evenly along both sides of each burner with a steady flame (mostly blue). If burner flames are not normal, check the orifice and burner for insects or insect nests. (See section on **CHECKING/CONVERTING THE BURNER ORIFICES** for instructions on burner removal and replacement.)

Check the burner ports at least annually for blockage by removing the burner (see orifice changing instructions) and visually inspect the gas intake tube for insects and nests. A clogged tube can lead to a fire beneath the grill.

WARNING

NEVER cover the *entire* cooking or grill surface with griddles or pans. Overheating will occur and burners will not perform properly when combustion heat is trapped below the cooking surface.

CAUTION: NEVER spray water on a hot gas unit.

ALLUMER DES INSTRUCTIONS (D'ALLUMAGE)

Lisez l'instruction entière avant que s'allumant et suivez ces instructions chaque fois vous lumière le barbecue.

ÉCLAIRAGE ÉLECTRONIQUE

1. Ouvrez tous les couvercles et enlevez toutes les couvertures des brûleurs que vous souhaitez vous allumer.
2. Arrêtez tous les boutons de commande de gaz à leurs positions.
3. Allumez le gaz à sa source.

Note: Aucune matière que la méthode d'éclairage vous emploient, n'allument pas le gaz à plus d'un brûleur à la fois. Les brûleurs adjacents de barbecue croix-mettront à feu et l'écoulement de gaz peut être restreint.

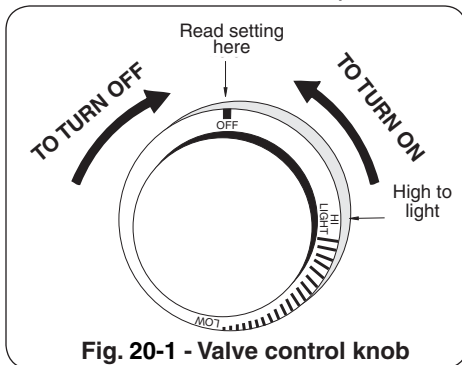

Fig. 20-1 - Valve control knob

ATTENTION: Si les brûleurs ne s'allument pas dans 5 secondes, enfoncez le bouton de commande et tournez le bouton à AU LOIN. ATTENDEZ 5 MINUTES avant de répéter l'étape 5. Si vous sentez le gaz suivez les instructions sur la couverture de ce manuel. Si les brûleurs ne s'allument toujours pas après que plusieurs tentatives, se rapportent aux instructions pour l'ÉCLAIRAGE MANUEL.

4. Enfoncez le bouton de commande pour que le brûleur soit allumé et tournez-le dans la position LÉGÈRE de HI, puis appuyez sur le bouton d'allumage. Une fois que le brûleur s'allume, libérez le bouton d'allumage.
5. Répétez l'étape 4 pour que chaque brûleur additionnel soit s'est allumé.

POUR LE PROPANE SEULEMENT

Les réservoirs de propane sont équipés d'un dispositif d'arrêt de sûreté qui peut ne pas causer le bas ou aucun gaz pression/flame aux brûleurs si le fonctionnement et allumer des instructions ne sont pas suivis exactement (voir la note importante dans la section de dépannage pour plus de détails.)

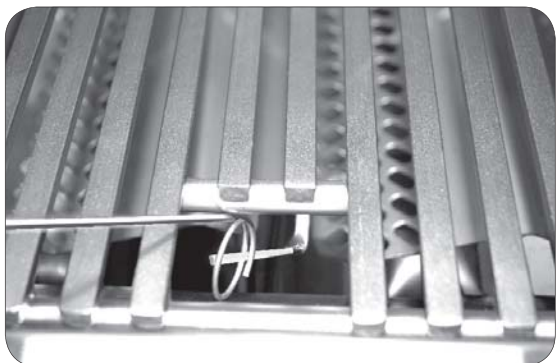

Fig. 20-3 - Éclairage manuel

RAPPEL-VOUS: POUR L'ÉCLAIRAGE MANUEL SÛR, PLACEZ Un ALLUMEUR BRÛLANT D'ALLUMETTE OU De BUTANE PRÈS Du BRÛLEUR - ALLUMEZ ALORS Le GAZ (voyez Fig. 20-3).

Note: Les barbecues dans quelques installations réalisent un meilleur mélange d'air/gas et mettront à feu plus rapidement si le bouton de commande de brûleur est d'abord tourné au delà de la LUMIÈRE de HI au BAS pour l'éclairage.

ÉCLAIRAGE MANUEL

ATTENTION: Attendez toujours 5 minutes le gaz à l'espace libre après que n'importe quelle tentative non réussie d'éclairage.

1. Suivez les étapes 1 à 4 (à gauche).
2. Insérez un allumeur brûlant de butane de long-baril, une allumette brûlante de long-tige, ou une allumette brûlante tenue par un support de prolongation de fil (Fig. 20-2) par les grilles à cuire au brûleur (Fig. 20-3). Pour des backburners, tenez la flamme contre le matériel perforé du brûleur arrière. Pour des sideburners, tenez la flamme contre le brûleur.
3. Tout en tenant l'allumette ou la flamme plus légère à côté du brûleur, enfoncez le bouton de commande approprié de brûleur et tournez-le dans le sens contraire des aiguilles d'une montre dans la position LÉGÈRE de HI. Quand les lumières de brûleur, enlèvent l'allumette ou s'assortissent.

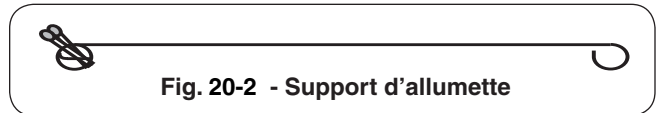

Fig. 20-2 - Support d'allumette

4. Si le brûleur ne s'allume pas, enfoncez **immédiatement** le bouton et tournez le bouton de commande de brûleur à AU LOIN. ATTENDEZ 5 MINUTES avant de répéter les étapes 2 à 4 des INSTRUCTIONS MANUELLES d'ÉCLAIRAGE.

COUPER LE GRIL

Pour couper le gril, enfoncez chaque bouton de commande de valve et tournez-le dans le sens des aiguilles d'une montre à la position de repos.

Fermez toujours la valve à l'offre de gaz après chaque utilisation du barbecue.

LIGHTING (IGNITION) INSTRUCTIONS

Read entire instructions before lighting, and follow these instructions each time you light the grill.

ELECTRONIC LIGHTING

1. Open all lids and remove all covers from the burners you wish to light.
2. Turn all gas control knobs to their **OFF** positions.
3. Turn on the gas at its source.

Note: No matter which lighting method you use, **DO NOT** turn on the gas to more than one burner at a time. Adjacent grill burners will cross-ignite, and gas flow may be restricted.

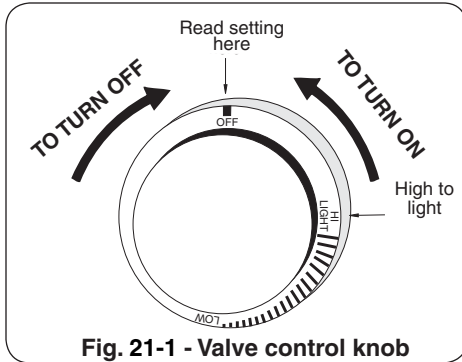

Fig. 21-1 - Valve control knob

CAUTION: If the burners do not light within five seconds, depress the control knob and turn the knob to **OFF**. WAIT FIVE MINUTES before repeating step 4. If you smell gas, follow the instructions on the cover of this manual. If the burners still do not light after several attempts, refer to the instructions for MANUAL LIGHTING.

4. Depress the control knob for the burner to be lit and turn it to the **HI LIGHT** position, then press the ignition button. Once the burner lights, release the ignition button.
5. Repeat step 4 for each additional burner to be lit.

FOR PROPANE ONLY

Propane tanks are equipped with a safety shutdown device that may cause low or no gas pressure/flame at the burners if operating and lighting instructions are not followed exactly (See important note in the TROUBLESHOOTING section for more details.)

MANUAL LIGHTING

CAUTION: Always wait five minutes for gas to clear after any unsuccessful lighting attempt.

1. Follow steps 1 through 4 (left).
2. Insert either a burning long-barrel butane lighter, a burning long-stem match, or a burning match held by a wire extension holder (Fig. 21-2) through the cooking grids to the burner (Fig. 21-3). For backburners, hold the flame against the perforated material of the backburner. For sideburners, hold the flame against the burner.
3. While holding the match or lighter flame next to the burner, depress the appropriate burner control knob and turn it counterclockwise to the **HI LIGHT** position.

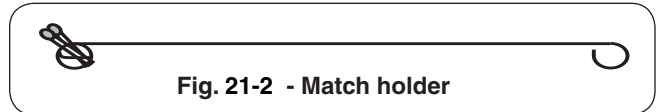

Fig. 21-2 - Match holder

When the burner lights, remove the lighter or match.

4. If the burner does not light, **IMMEDIATELY** depress the knob and turn the burner control knob to **OFF**. WAIT FIVE MINUTES before repeating steps 2 through 4 of the MANUAL LIGHTING INSTRUCTIONS.

Note: Some installations achieve a better air/gas mixture and may ignite quicker if the burner control knob is first turned beyond **HI LIGHT** to **LOW** for lighting.



Fig. 21-3 - Manual lighting

REMEMBER: FOR SAFE MANUAL LIGHTING, PLACE A BURNING MATCH OR BUTANE LIGHTER BESIDE THE BURNER - **THEN TURN ON THE GAS** (see Fig. 21-3).

SHUTTING OFF THE GRILL

To shut off the grill, push in each valve control knob and turn it clockwise to the **OFF** position.

Always close the valve to the gas supply after each use of the grill.

ROTISSERIE INSTRUCTIONS

USING YOUR BACKBURNER AND ROTISSERIE

Rotisserie cooking with the backburner is accomplished without use of the main burners. Follow the steps in the appropriate sections below to set up and use these accessories (see PARTS LIST for image).

SET UP

1. Remove the backburner cover (if present) by sliding it upward off the backburner.
2. Remove the cooking grids from your barbecue (if necessary) to obtain maximum clearance for larger cuts. The flavor grids may also be removed if required.
Tip: Aluminum foil or a baking pan may be placed over the main burners, a little forward of center, to catch excess drippings from the meat.
3. Attach the rotisserie motor to the barbecue frame by inserting the tab of the bracket attached to the motor into the slot on the right of the barbecue so that the spit rod will fit into the motor drive socket from the left. If left-side spit support is not already in place, insert it into the tab on the left side of the barbecue at this time.
4. Follow the LIGHTING INSTRUCTIONS to light the backburner.
5. Allow the backburner to preheat for approximately 10 minutes on **HI LIGHT** setting.

PUTTING THE MEAT ON THE SPIT ROD

1. Slide the meat and spit prongs onto the spit rod so the meat is centered and balanced as well as possible.
2. Tighten the spit prongs into place so that the meat remains in a fixed position on the rod and the meat rotates with the rod.

Important: The counterbalance, which is included with your rotisserie kit, should be used to balance the load on your rotisserie and prolong the life of your motor. Heavy unbalanced meats can stress the rotisserie motor and may cause motor failure.

USING THE COUNTERBALANCE SUPPLIED WITH YOUR ROTISSERIE

1. Hold the spit rod at each end and lift. **Do not grip the rod.** Let the rod rotate so the heavy side of the meat hangs down naturally.

2. Turn the counterbalance on the spit so the counterbalance rod and weight point upward, or opposite from the heavy side of the meat. Tighten the counterbalance rod in the hub against a flat surface of the spit rod to secure (Fig. 22-1).

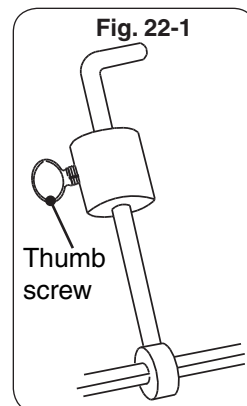

3. Loosen the thumb screw and slide the weight along the counterbalance rod to balance the meat. Since meats are not a uniform shape, it may not be possible to achieve a perfect balance. Properly balanced meat should not rotate when you hold the spit rod loosely by the ends.
4. Make sure the counterbalance will not strike the barbecue frame when the rotisserie is started.

RUNNING THE ROTISSERIE

1. Place the pointed end of the spit rod into the motor drive socket and rest the handle end of the spit rod in the spit bracket on the right side of the barbecue.
2. Plug in (if necessary) and turn on the rotisserie motor.
3. Use a standard roasting guide to estimate the length of time for your meat. A meat thermometer may also be used to tell when your favorite cuts are cooked to your liking. When testing temperatures with a thermometer, turn off the rotisserie motor and turn the backburner on **LOW**. This will keep the meat from overcooking on one side.

Note: When burning properly, the backburner flames will be blue with yellow tipping, and the grating will glow red. The first time it is used, the backburner may smoke a little.

Important: Operate your backburner with the oven closed. This simulates an oven effect and helps your meat cook faster. Constant rotation of the spit ensures even cooking and maximum retention of juices.

Note: On large cuts of meat or whole turkeys, it may be necessary to reduce the heat from your backburner. Cooking your food at a lower temperature for a longer period of time will keep the outer surface from burning while cooking the interior of your meat. In any case, it is normal for the back burner grating to glow red when operating properly.

GRILL BRUSH (optional)

Purchase a Fire Magic® stainless-steel grill brush (sold separately) to keep your grill cleaner. It comes with scraper for large particles and a replaceable head with brass bristles for overall cleaning.



Fig. 23-1

Grill brush with replacement head

WARMING RACK (if equipped)

The warming rack (Fig. 23-2) is packed separately.

To install the warming rack, lift the front of the rack up slightly and insert the rack hangers into the two holes in the back of the inner oven hood. Then lower the front of the rack into a level position to lock the rack in place.

To remove the warming rack, lift up on the front of the rack until the rack hangers pull free from their supporting holes.

Note: Removing the warming rack before using the rotisserie will leave more clearance for the meat being cooked. (if applicable)

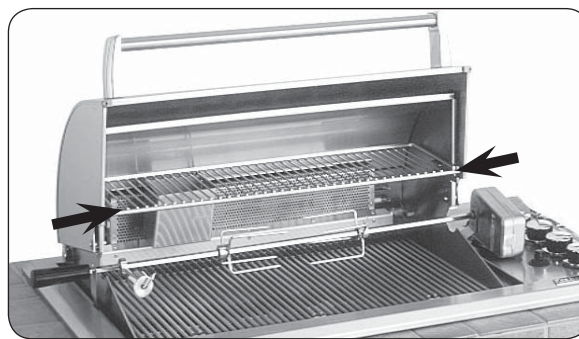

Fig. 23-2 Warming rack in place inside oven

THE COOKING GRID LIFTER

Hold the grid lifter by gripping the center section with the prongs pointing down (use an oven mitt or heavy glove if the grill is hot). Insert the notched end of the grid lifter into the cooking grid, in front of the midway point (front to back; Fig. 23-3), and central (left to right; Fig. 23-4). Twist the grill lifter (clockwise or counterclockwise) so the handle is parallel to the grill rods. This “seats” the spiked end of the grid lifter between two rods, enabling you to safely lift out the grid. Lift slowly and adjust the grid lifter, if necessary, for balance.



Fig. 23-3

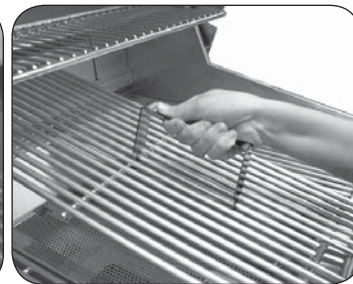

Fig. 23-4

Placement of the grid lifter in cooking grid

THE DRIP TRAY

The drip collection system allows you to brush or scrape excess dried residue from the grilling area directly into the drip tray (see the parts list for more information).

THE FLAVOR GRID(S)

Place each flavor grid directly over a burner or burner pair. Center each grid over the burner, oriented as shown in Fig. 23-5.

Note: This allows heat from the burners to be evenly distributed throughout the cooking area. The flavor grids heat and cool quickly, making the grill very responsive to changes in heat from the burners.

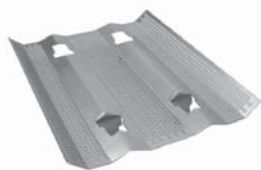

Fig. 23-5

WOOD CHIP SMOKER

Your optional backburner is supplied with a wood chip box. The wood chip box is designed to sit on top of the backburner assembly over the notch in the heat deflector (see Fig. 23-6). This box is designed to be used when the backburner is in use. To use the box, just dampen your favorite wood chips and put them inside then set it in place. If you wish to refill the wood chip box when it is hot, you may carefully handle it using a pair of insulated pliers. You must be very careful not to get burned.

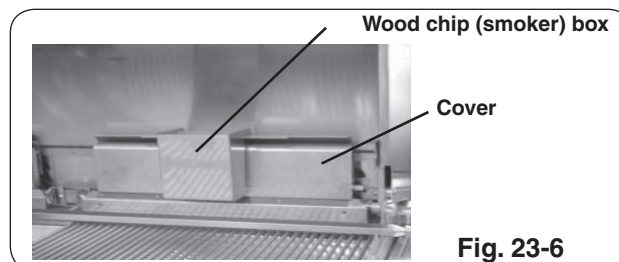

Fig. 23-6

CARE & CLEANING

APPLIANCE MUST BE COMPLETELY COOL WHEN CLEANING. DO NOT SPRAY ANY CLEANER OR LIQUIDS ON THE APPLIANCE WHEN HOT.

The appliance *must* be cleaned as often as once a month (depending on use) to prevent grease build-up and other food deposits.

A clean and well maintained appliance prevents the risk of grease fires. Reference the GRILL MAINTENANCE AND SAFETY section.

COOKING GRIDS

Before and after each use, clean the cooking grids with a Fire Magic Grill Brush (sold separately). Before initial use and periodically, it is suggested that the cooking grids be washed with a mild soap and warm water solution.

INTERIOR

THE **BURNER PORTS** MUST BE KEPT CLEAN TO ENSURE PROPER IGNITION AND OPERATION.

Remove the burner (see the CHECK BURNER ORIFICES section) and clean the ports as required. Also inspect and clean the burner inlet for insects and nests. A clogged burner can lead to a fire in the bottom of the appliance.

The inside of the appliance may be cleaned periodically with oven cleaner if desired. Follow the oven cleaner instructions for proper use.

Be careful not to get oven cleaner on the outside surface of the appliance as it can permanently damage the finish.

EXTERIOR

Stainless steel surfaces when exposed to temperatures produced by the grilling process will change color. The stainless steel will change color from silver to brown and blue. This can be removed by using stainless steel cleaner.

Clean your appliance by first using stainless steel grill cleaner to remove grease and dirt. Always wipe with the grain (See Fig. 24-1). Next, apply stainless steel polish and wipe down using polish wipes to restore the stainless steel color.

If your appliance is installed in a seaside (salt air) or poolside (chlorine) location, it will be more susceptible to corrosion and must be maintained/cleaned more frequently. Do not store chemicals (such as chlorine or fertilizer) near your stainless steel appliance.

Due to the nature of stainless steel, surface iron oxide deposits may appear. Do not be alarmed – these deposits are removable with stainless steel cleaner through prompt and periodic maintenance. If not attended to promptly, permanent pitting may occur.

By following these recommendations, you will enjoy the beauty and convenience of your appliance for many years to come.

PROTECTING YOUR APPLIANCE FROM THE WEATHER

An optional cover will protect your appliance when not in use. Allow to cool before covering. Please specify the model number and serial number of your appliance when ordering a cover.



Fig. 24-1 Wipe with grain

TROUBLESHOOTING

If you have trouble with the unit, please use this list to identify the problem. By trying one or more of the solutions to the possible cause, you should be able to solve the problem. If this list does not cover your present problem, or if you have other technical difficulties with the unit, please contact your local dealer.

PROBLEM	POSSIBLE CAUSE	CORRECTION
Ignition system failure	<ol style="list-style-type: none"> 1. Improper air shutter adjustment 2. Ignition wire disconnected 3. Igniter malfunction 4. Low gas pressure 5. Dead battery 	<ol style="list-style-type: none"> 1. Adjust air shutters. 2. Reconnect wires into generator. 3. Contact dealer for replacement. 4. Have gas company check the operating pressure at the unit. 5. Replace battery.
Insufficient heat / low flame	<ol style="list-style-type: none"> 1. Burner ports clogged 2. Improper air shutter adjustment 3. Using propane orifice for natural gas 4. Low gas pressure/flame (natural) 5. Low gas pressure/flame (propane) 6. L.P. regulator hose cracked due to age 	<ol style="list-style-type: none"> 1. Remove burners and clean out ports. 2. Adjust air shutters. 3. Change orifices. 4. Have gas company check the operating pressure at the unit. 5. Refill propane tank, or reset propane tank safety*: Shut off all valves (including propane tank) and follow lighting instructions exactly. 6. Replace L.P. regulator hose.
Uneven heating	<ol style="list-style-type: none"> 1. Burner ports partially blocked by debris 2. Small spiders or insects in burner 3. Improper air shutter adjustment 	<ol style="list-style-type: none"> 1. Remove burners and clean out ports. 2. Inspect burners for spider webs or other debris that may block gas flow. 3. Adjust air shutters.
Burner goes out on LOW	<ol style="list-style-type: none"> 1. Valve "Low" setting needs adjustment 	<ol style="list-style-type: none"> 1. Light burner on HIGH, immediately turn to LOW setting. Remove knob from valve and using a small flat screwdriver, slowly turn the adjustment screw in the stem, a little at a time (30° to 45°), in either direction, until the flame is approximately 1/4" in height from burner ports.
Rotisserie noisy	<ol style="list-style-type: none"> 1. Rotisserie out of balance 	<ol style="list-style-type: none"> 1. Adjust counterbalance.

Note: *Propane tanks are equipped with a safety shutdown device that may cause low or no gas/flame at the burners if operating and lighting instructions are not followed exactly. **If you suspect the propane tank safety shutoff is in effect:** 1) Shut off all grill valves. 2) Shut off tank valve. 3) Open and close a main burner valve. 4) Open tank valve. 5) Follow the LIGHTING INSTRUCTIONS. Lighting instructions are located in the owner's manual and printed on the unit's metal drip tray. If the problem persists, continue troubleshooting, or contact your local dealer or distributor for assistance.

REPLACING THE IGNITER BATTERY

1. Remove the igniter cover by turning it counterclockwise.



Important: Do not attempt to pull or turn the rubber cap.



2. Remove battery for replacement. The battery is reinstalled with the negative (-) end out.



3. After properly inserting the battery, replace the igniter cover by turning the cap clockwise.



Note: If you have accidentally removed the rubber cap, follow the instructions below to replace it.

1. Pull the rubber cap and the inner plastic sleeve apart.
 2. Carefully insert the rubber cap into the igniter cover so it sits behind inner lip.
 3. Turn the cap over and slide the inner plastic sleeve into the cap.



WARRANTY

PETERSON FIRE MAGIC GRILLS AND ACCESSORIES LIMITED WARRANTY

Robert H. Peterson Co. ("RHP") warrants your Fire Magic® grill to be free from defects in material and workmanship.

Fire Magic® cast stainless-steel burners, stainless-steel cooking grids, and stainless-steel housings are warranted for as long as you own your Fire Magic® grill -- **LIFETIME**. (Except as noted below.)

Fire Magic Choice stainless steel tubular burners are warranted for **TWENTY (20) YEARS**.

Fire Magic® cast brass burners, brass valves, inner liners, manifold assemblies, porcelain housings (including ovens and barbecue faces), and backburner assemblies (except ignition parts) are warranted for **FIFTEEN (15) YEARS**.

Fire Magic® Electric Grills, including stainless steel grid, and housings are warranted for **TEN (10) YEARS**.

Fire Magic® Infra-red burners, flavor grids, Charcoal stainless steel grills, and Smokers are warranted for **FIVE (5) YEARS**; except for the charcoal pan, charcoal grid, wood pellet screen, thermometer, and ash tray; which are warranted for **ONE (1) YEAR**.

Fire Magic® sideburners and all other Fire Magic® grill components (except ignition and electronic parts) are warranted for **THREE (3) YEARS**.

Fire Magic® ignition systems (excluding batteries), electronic components (including lights and thermometers), and grill accessories are warranted for **ONE (1) YEAR**.

A COPY OF YOUR SALES SLIP FOR PROOF OF PURCHASE IS REQUIRED

This warranty applies to the original purchaser for products which are installed in the United States or Canada and which are operated and maintained as intended for single family residential usage. This warranty is valid only with proof of purchase, shall commence on the date of purchase, and shall terminate (both as to original and any replacement products) on the anniversary date of the original purchase of the product stated on the above schedules.

This warranty covers defects in material and workmanship. This warranty **does not** cover parts which become defective as a result of negligence, misuse, use not in compliance with the Owner's Manual/Installation Instructions, accidental damage, improper handling, improper storage, improper installation, **lack of required routine maintenance** (as specified in the Owner's Manual/Installation Instructions), electrical damage, local gas impurities or failure to protect against combustibles. Product must be installed (and gas must be connected) as specified in the Owner's Manual/Installation Instructions by a **qualified professional installer**. Modifications to products which are not specifically authorized will void this warranty. Accessories, parts, valves, remotes, etc. when used must be Peterson products or this warranty is void. Warranted items will be repaired or replaced at Peterson's sole discretion. This warranty **does not** apply to rust, corrosion, oxidation, or discoloration unless the affected part becomes inoperable.

This warranty **does not** cover labor or labor related charges, except as provided by separate specific written programs from the Peterson Co. All repair work must be performed by a qualified professional service person and requires prior approval of Peterson.

Peterson may require the defective product or part to be returned to the factory to determine the cause of failure. Peterson will pay freight charges if the product or part is determined to be defective. This warranty does not cover breakage in shipment from our (Independent) distributor to its customer if the damage is determined to have occurred during that shipment.

This warranty specifically excludes liability for **indirect, incidental**, or consequential damages. Some states and provinces do not allow the exclusion or limitation of incidental or consequential damages, so the above exclusion may not apply to you. This warranty gives you specified legal rights, and you may have other rights that vary from state to state or province.

For additional information regarding this warranty, or to place a warranty claim, contact the R. H. Peterson dealer where the product was purchased.

When contacting your Peterson dealer or the R. H. Peterson Co., please provide the following information:

- Your name, address, telephone number, e-mail
- Sales receipt showing where purchased and date purchased
- Model number, serial number of product, date code
- Relevant information: installer, additions, repairs, when defect was first noted

**TO REGISTER YOUR PRODUCT ONLINE GO TO: WWW.RHPETERSON.COM,
AND CLICK ON PRODUCT REGISTRATION. THANK YOU FOR YOUR PURCHASE.**

Quality Check			Date: _____		
Burner Orifices	Nat.	L.P.	Leak Test: _____	Model#:	_____
Main:	_____	_____	Burn Test: _____	Serial#:	_____
Other:	_____	_____	Gas Type: <u>Nat. / L.P.</u>	Air Shutter:	_____
				Inspector:	_____