

8. To reset the Filter Clean indicator once the filter has been cleaned, press and hold the Fan Speed (⚙️) and Timer (⌚) buttons simultaneously for 3 seconds. The Filter Clean Indicator (👤) will disappear from the screen. It will then monitor another 3 months of use to indicate when the next cleaning is required.

**Filter Life** – The filter has been designed to never need replacement, however, it does need servicing. We recommend that under normal conditions of continuous use, the filters should be cleaned at least every 3 months to help maintain optimal performance. Filter cleaning times may vary depending on the air quality of the room where the air purifier is being used. Should the filter become damaged during cleaning, replacements are available by calling 1-800-253-2764.

**CLEANING/MAINTENANCE INSTRUCTIONS**

Turn off and unplug the unit before cleaning.

1. The outside of the air cleaner can be cleaned with a soft, damp cloth.
2. The air outlet grills can be cleaned of dust with a small soft brush or cloth.

**WARNING:** Do not allow moisture to come in contact with the main housing of the air cleaner.

**TROUBLESHOOTING**

Problem	Solution
Air cleaner will not operate	<ul style="list-style-type: none"> <li>• Check to make sure the air cleaner is plugged in.</li> <li>• Check to make sure the air cleaner is on by pressing the Power Button (⏻).</li> </ul>
Decreased airflow	<ul style="list-style-type: none"> <li>• If the Filter Clean Indicator (👤) is shown, the PERMAtech™ filter should be cleaned.</li> <li>• Check the filter to make sure it is in good condition.</li> <li>• Check to ensure nothing is blocking air inlet (sides) and filtered air outlet (top).</li> </ul>

**AIR CLEANER SERVICE INSTRUCTIONS**

1. DO NOT attempt to repair or adjust any electrical or mechanical functions on this unit. Doing so will void the warranty. The inside of the unit contains no user serviceable parts other than the filter. All servicing should be performed by qualified personnel only.
2. If you need to exchange the unit, please return it in its original carton, with a sales receipt, to the store where you purchased it. If you are returning the unit more than 30 days after the date of purchase, please see the enclosed warranty.
3. Should your air cleaner require service, please call **1-800-253-2764** in North America for further assistance. A return authorization will be given when you call.
4. ☒ If you have any other questions or comments, feel free to write to us:

Bonaire®  
 JCS/THG, LLC  
 Consumer Service Department  
 13120 Jurupa Avenue  
 Fontana, CA 92337

Visit our website at [www.bonaire.com](http://www.bonaire.com)

**FIVE (5) YEAR LIMITED WARRANTY**

**SAVE THIS WARRANTY INFORMATION**

- A. This Warranty applies only to the original purchaser of this product.
- B. This Warranty applies ONLY to repair or replacement of any supplied or manufactured parts of this product that, upon inspection by JCS/THG, LLC authorized personnel, is shown to have failed in normal use due to defects in material or workmanship. JCS/THG, LLC will determine whether to repair or replace the unit. This Warranty does not apply to installation expenses.
- C. Operating this unit under conditions other than those recommended or at voltages other than the voltage indicated on the unit, or attempting to service or modify the unit, will render this WARRANTY VOID.
- D. Unless otherwise proscribed by law, JCS/THG, LLC shall not be liable for any personal injury, property or any incidental or consequential damage of any kind resulting from malfunctions, defects, misuse, improper installation or alteration of this product.
- E. All parts of this product, excluding filters, which are covered under separate warranty, are guaranteed for a period of 5 years as follows:
  1. Within the first 30 days from date of purchase, the store from which you purchased your product should replace this product if it is defective in material or workmanship (provided the store has in-stock replacement.) If you intend to assert any claim in connection with the product, please follow the instructions in paragraph F.
  2. Within the first 60 months from date of purchase, JCS/THG, LLC will repair or replace the product if it is defective in material or workmanship, subject to the conditions in paragraph G.
- F. If you have any other problem or claim in connection with this product, please write to our Consumer Service Department.

- G. IMPORTANT RETURN INSTRUCTIONS. Your Warranty depends on your following these instructions if you are returning the unit to JCS/THG, LLC:

1. Carefully pack the item in its original carton or other suitable box to avoid damage in shipping.
2. Before packing your unit for return, be sure to enclose:
  - a) Your name, full address with zip code and telephone number
  - b) A dated sales receipt or PROOF OF PURCHASE,
  - c) Your \$12.50 check for return shipping and handling, and
  - d) The model number of the unit and the problem you are having. (Enclose in an envelope and tape directly to the unit before the box is sealed.)
3. JCS/THG, LLC recommends you ship the package U.P.S. ground service for tracking purposes.
4. All shipping charges must be prepaid by you.
5. Mark the outside of your package:

Bonaire®  
 JCS/THG, LLC  
 13120 Jurupa Avenue  
 Fontana, CA 92337

SHIPPING AND HANDLING CHARGES: \$12.50 (USD)

This Warranty gives you specific legal rights, and you may have other rights which vary from state to state. The provisions of this Warranty are in addition to, and not a modification of, or subtraction from, the statutory warranties and other rights and remedies contained in any applicable legislation. To the extent that any provision of this Warranty is inconsistent with any applicable law, such provision shall be deemed voided or amended, as necessary, to comply with such law.

© 2006 JCS/THG, LLC  
 Bonaire®, the Bonaire logo® and PERMAtech™ are trademarks of JCS/THG, LLC.

BAP401006EM1 Printed In China

**BIONAIRE**  
 PERMAtech™  
 ionizing air cleaner  
 MODEL BAP4010



Read instructions before operating.  
 Retain for future reference.

**Instruction Leaflet**



**INFO-LINE**  
 If after having read this leaflet, you have any questions or comments on your air cleaner, call **1-800-253-2764** in North America.  
 9100040001717

## **⚠️ AIR CLEANER SAFETY**

# PLEASE READ AND SAVE THESE IMPORTANT SAFETY INSTRUCTIONS

### IMPORTANT SAFEGUARDS

When using electrical appliances, basic safety precautions should always be followed to reduce the risk of fire, electric shock, and injury to persons, including the following:

- Read all instructions before using the appliance.
- To avoid fire or shock hazard, plug the appliance directly into a 120V AC electrical outlet.
- If the filter is covered by a bag when shipped: Remove plastic bag before use.
- Keep the cord out of heavy traffic areas. To avoid fire hazard, NEVER put the cord under rugs, near heat registers, radiators, stoves, or heaters.
- To protect against electrical hazards, DO NOT immerse in water or other liquids. Do not use near water.
- Close supervision is necessary when any appliance is used by or near children, or disabled persons.
- Always unplug the air cleaner before moving it, opening the grill, changing the filters, cleaning, or whenever the air cleaner is not in use. Be sure to pull by the plug and not the cord.
- NEVER drop or insert any object into any openings.
- DO NOT operate any appliance with a damaged cord or plug, if motor fan fails to rotate, after the appliance malfunctions, or if it has been dropped or damaged in any manner. Return appliance to manufacturer for examination, electrical or mechanical adjustment, or repair.
- Use appliance only for intended household use as described in this manual. Any other use not recommended by the manufacturer may cause fire, electric shock, or injury to persons. The use of attachments not recommended or sold by JCS/THG, LLC may cause hazards.
- DO NOT use outdoors.

- NEVER block the air openings, grills/outlets or place on a soft surface such as a bed or sofa, as this could cause the unit to tip over, blocking the Air Intake Opening/Grill.
- Keep unit away from heated surfaces and open flames.
- DO NOT attempt to repair or adjust any electrical or mechanical functions on this unit. Doing so will void your warranty. The inside of the unit contains no user serviceable parts. All servicing should be performed by qualified personnel only.
- **WARNING:** To reduce the risk of fire or electric shock, DO NOT use this air cleaner with any solid-state speed control device.
- DO NOT place anything on top of unit.

# PLEASE READ AND SAVE THESE IMPORTANT SAFETY INSTRUCTIONS

### CONSUMER SAFETY INFORMATION



**CAUTION:** THIS PRODUCT IS EQUIPPED WITH A POLARIZED PLUG (a plug having one blade wider than the other). This plug will fit into the power outlet only one way. If the plug does not fit

fully into the outlet, reverse the plug. If it still does not fit, contact qualified personnel to install the proper outlet.

### DO NOT DEFEAT THE SAFETY PURPOSE OF THIS POLARIZED PLUG IN ANY WAY.

### CORD AND PLUG INSTALLATION SAFETY INSTRUCTIONS

The length of cord used on this appliance was selected to reduce the hazards of becoming tangled in, or tripping over a longer cord. If a longer cord is necessary, an approved extension cord may be used. The electrical rating of the extension cord must be equal to or greater than the rating of the air cleaner. Care must be taken to arrange the extension cord so that it will not drape over the countertop or tabletop where it can be pulled on by children or accidentally tripped over.

**Thank you for choosing a Bonaire® air cleaner. To ensure the best performance from your air cleaner, please read and save the following instructions.**

### IONIZER

Your air cleaner has an optional ionizer feature, which, when turned on, releases negative ions into outgoing filtered air. Ions are tiny particles that carry a positive or negative charge. These ions exist naturally around us, in the air, water, and ground. Both positive and negative ions are colorless, odorless, and completely harmless. Negative ions help the air purification process by attaching themselves to very small airborne particles in the room.

These particles take on a negative charge and may join with positively charged particles such as dust, pollen, smoke, and pet dander to form larger particles that are then more readily captured by the filter system, or may be attracted to positively charged surfaces throughout the home, like walls or floors. This may occur more frequently when the filter is nearing the end of its functional life expectancy and is able to capture less of the charged particles.

You may also note after extended use, that dust has collected around the grills or front panel. This is from the ionization affect caused by the negative ions exiting from the air outlet. This is additional evidence of the air cleaning effectiveness of negative ions. The dust can be easily removed with a clean, damp cloth or soft brush.

Finally, using your ionizer may result in an occasional popping or cracking sound. This is a normal sound, generally caused by a small build-up of ions that, when discharged, cause the popping or cracking sound.

**NOTE:** It is important to clean the HEPA-type filter at the recommended intervals.

Using the ionizer in conjunction with dirty filters may result in dirty particles exiting the air purifier and being attracted to walls, carpets, furniture, or other household objects. These dirty particles may prove very difficult to remove. Homes with excessive amounts of pet dander, dust, or smoke may decrease the life expectancy of the HEPA-type filtration system and may interfere with the ionization process. You may want to run the ionizer less often and check the condition of the HEPA-type filter(s) more frequently in order to reduce particles from being attracted to surfaces throughout your home as mentioned above.

### KNOW YOUR AIR CLEANER

- A. Display Screen
  - a. Timer Indicator (⌚)
  - b. Ionizer Indicator (⊗)
  - c. Fan Speed Indicator (⚙️)
  - d. Filter Clean Indicator (🧹)
- B. Control Panel
  - a. Power Button (⏻)
  - b. Speed Button (⚙️)
  - c. Ionizer Button (⊗)
  - d. Timer Button (⌚)
- C. Filter Slot
  - a. PERMAtech™ Filter
  - b. Filter Tabs
- D. Base
- E. Power Cord (Not Shown)
- F. Air Intake Grills
- G. Filtered Air Outlet

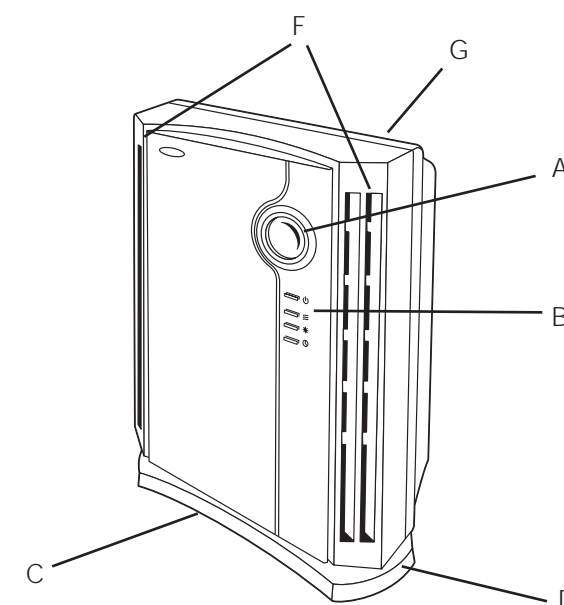

### OPERATING INSTRUCTIONS

1. Carefully unpack your air cleaner. Select a firm level place where there are no obstructions to the air inlet (side grills) or filtered air outlet (top grills).
2. Plug into a 120V AC electrical outlet. The air cleaner will beep twice signaling that it is ready for use.
3. Press the Power Button (⏻) once. The air cleaner will be turned onto HIGH fan speed.
4. Press the Speed Button (⚙️) to select the desired air cleaning setting. Press once to select MEDIUM fan speed, or twice to select LOW fan speed, or a third time to return to HIGH fan speed.
5. To activate the ionizer function, press the Ionizer Button (⊗) once. The Ionizer Indicator (⊗) will illuminate on the Display Screen. To deactivate the ionizer, press the Ionizer Button (⊗) again.
6. For optimum air filtration, it is recommended to operate the air cleaner continuously. Its rugged motor has been designed to give many years of use. For continuous use, it's recommended to operate the air cleaner at the MEDIUM fan speed. For quieter operation or use in a bedroom, select the LOW fan speed. When high levels of air pollution are present, select the HIGH fan speed to quickly circulate and filter air in the room.

### SETTING THE TIMER

Your PERMAtech™ air cleaner is equipped with an 8-Hour Timer that will automatically turn the power off after the desired amount of time has been reached.

1. Press the Timer Button (⌚) to set the number of hours the air cleaner will operate, and then automatically turn off.
2. The timer can be set for 1 to 8 hours by pressing the Timer Button (⌚) and increasing the time in increments of 1 hour.
3. The Timer Indicator (⌚) and number of hours selected will flash a few times, then remain illuminated on the Display Screen.
4. When the timer has elapsed, the air cleaner will beep 3 times and turn off.
5. To cancel the timer operation press the Timer Button (⌚) until the Timer Indicator (⌚) on the Display Screen is no longer illuminated or turn the power off by pressing the Power Button (⏻) on the Control Panel. Another way to cancel the Timer feature is to press and hold the Timer Button (⌚) for 3 seconds until the Timer Symbol (⌚) is turned off.

### PERMATECH™ FILTER CLEANING INSTRUCTIONS

1. Every few weeks, check the condition of the filter.
2. After approximately 3 months of operation a Filter Clean indicator (🧹) will be shown on the Display Screen notifying you that the filter should be cleaned prior to further use.
3. Turn off and unplug the air cleaner.
4. Lay the unit down on its side.

5. To remove the PERMAtech™ filter, press the movable filter tab against the stationary filter tab on the underside of the housing to release the filter, and slide it out of the air cleaner. (See Fig. 1 & 2)

6. To clean the PERMAtech™ filter use a brush attachment with your vacuum cleaner. Run the attachment along the inlet and outlet side of the filter trying to clean between the pleated filter layers. (See Fig. 3)

**Do not use water or any other household cleaners or detergents to clean the PERMAtech™ filter. NOTE: Vacuuming will restore performance of the PERMAtech™ filter, however, the filter may appear stained. This is normal and does not affect the performance in any way.**

7. To reinstall the PERMAtech™ filter, slide it back into the underside of the housing, with the movable tab facing the bottom rear of the air cleaner. The filter will lock into place once inserted completely within the housing.

