

This Owner's Manual is provided and hosted by [Appliance Factory Parts](#).



GOLDSTAR DHA4012DL Owner's Manual

**[Shop genuine replacement parts for GOLDSTAR
DHA4012DL](#)**



[Find Your GOLDSTAR Dehumidifier Parts - Select From 99 Models](#)

----- Manual continues below -----

Dehumidifier

SERVICE MANUAL

**MODEL: DH3010B(DHA3012DL)
DH4010B(DHA4012DL)
DH5010B(DHA5012DL)**

CAUTION

- BEFORE SERVICING THE UNIT,
READ THE SAFETY PRECAUTIONS IN THIS MANUAL.
- ONLY FOR AUTHORIZED SERVICE.

CONTENTS

1. PREFACE

1.1 SAFETY PRECAUTIONS	3
1.2 FEATURES	3
1.3 DIMENSIONS	3
1.4 SPECIFICATIONS	4
1.5 CONTROL	5
1.6 HOW TO OPERATE DEHUMIDIFIER	5
1.6.1 HOW DOES THE DEHUMIDIFIER WORK?	5
1.6.2 LOCATION FOR THE DEHUMIDIFIER	5
1.6.3 MICRO SWITCH	6
1.6.4 AUTO DEFROST	6
1.6.5 HUMIDISTAT	6
1.6.6 DRIER	6

2. CIRCUIT DIAGRAM

3. DISASSEMBLY INSTRUCTIONS

3.1 MECHANICAL PARTS	10
3.1.1 BUCKET AND AIR FILTER	10
3.1.2 FRONT GRILLE	10
3.1.3 CABINET AND CONTROL BOX	10
3.2 CONTROL PARTS	11
3.2.1 ROTARY SWITCH, HUMIDISTAT AND NEON LAMP	11
3.2.2 CAPACITOR	11
3.2.3 DEFROST CONTROL	11
3.2.4 THERMOSTAT CONTROL	11
3.2.5 MICRO SWITCH ASSY	11
3.2.6 POWER CORD ASSY	11
3.2.7 FAN AND MOTOR	12
3.2.8 SHROUD AND BARRIER	12
3.3 REFRIGERATING CYCLE	13
3.3.1 CONDENSER, EVAPORATOR AND CAPILLARY TUBE (HEAT EXCHANGE ASSEMBLY)	13
3.3.2 P.T.C. OR OVERLOAD PROTECTOR (O.L.P.) FOR RECIPROCATING COMPRESSOR	14
3.3.3 ROTARY COMPRESSOR	14
3.4 HOW TO REPLACE REFRIGERATION SYSTEM	15

4. TROUBLESHOOTING GUIDE

5. EXPLODED VIEW - INTRODUCTION

6. REPLACEMENT PARTS LIST

1. PREFACE

This Service Manual provides various service information, containing the mechanical and electrical parts etc. This dehumidifier was manufactured and assembled under the strict quality control system.

The refrigerant is charged at the factory. Be sure to read the safety precaution prior to servicing the unit.

1.1 SAFETY PRECAUTIONS

- Disconnect power supply before servicing or replacing any electrical or non-electrical component.
- Do not cut off the grounding prong or alter the plug in any manner at any circumstances.

1.2 FEATURES

- Quiet
- High efficiency
- Adjustable humidistat
- Automatic defrost
- Automatic shut-off
- Bucket-full indicator light
- Easy roll casters
- Removable & large capacity bucket.
- Washable air filter
- 2 fan speeds
- Drain hose connection.

1.3 DIMENSIONS (mm/in)

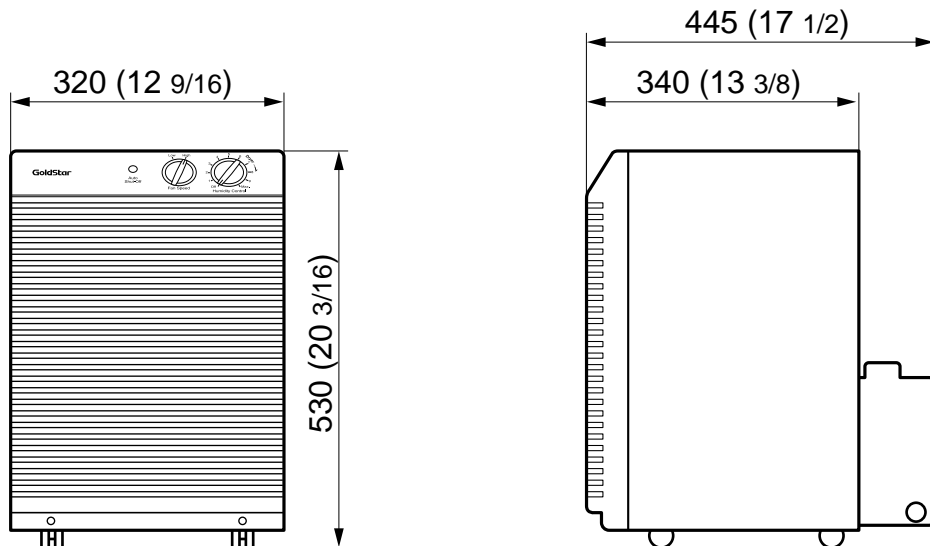

1.4 SPECIFICATIONS

ITEMS		MODELS	DH3010B (DHA3012D*)	DH4010B (DHA4012D*)	DH5010B (DHA5012D*)
CAPACITY (Pint/Day)			30	40	50
POWER SUPPLY (Phase, V, Hz)			1ø, 115V, 60Hz		
REFRIGERANT			R134a	R22	
REFRIGERANT CHARGE, oz(g)			4.76(135)	5.11(145)	7.05(200)
CONTROL, DEFROST			OPEN : 32°F(0°C $\pm\frac{2}{3}$) CLOSE : 52.6°F(13°C $\pm\frac{3}{3}$)	-	OPEN : 32°F(0°C $\pm\frac{2}{3}$) CLOSE : 53.6°F(13°C $\pm\frac{3}{3}$)
THERMOSTAT			OPEN : 28.4°F(-2°C ± 2) CLOSE : 55.4°F(13°C ± 2)	OPEN : 26.6°F(-3°C ± 2) CLOSE : 55.4°F(13°C ± 2)	OPEN : 28.4°F(-2°C ± 2) CLOSE : 55.4°F(13°C ± 2)
HUMIDISTAT			CONTROL RANGE : 20% ~ 80% RH NORMAL SETTING : 42 ± 5% RH		
COMPRESSOR MODEL NO.			LX86HACG	QA075CH	QA082CH
P.T.C. ASSEMBLY	TYPE		P220MC		
	TIME		WORKING TIME: 0.2 ~ 0.7 sec. RETURN TIME: 60 sec.		
	MAXIMUM	AMPERE	7A		
		VOLTAGE	300V		
PROTECTOR			<ul style="list-style-type: none"> • OVERLOAD PROTECTOR FOR COMPRESSOR • INTERNAL PROTECTOR(FUSE) FOR MOTOR 		
CAPACITOR			-	25μF, 270VAC	
SWITCH, ROTARY			6A/125VAC, 12A/250VAC		
MOTOR ASSEMBLY, SINGLE			Shaded pole motor, 65W/1A , Thermal cutoff : 266°F/130°C		
SWITCH ASSEMBLY, MICRO			16A/125VAC, 8A/250VAC		
OUTSIDE DIMENSIONS W x H x D, mm(in)	WITHOUT BUCKET		320 x 530 x 340 (12 9/16 x 20 13/16 x 13 3/8)		
	WITH BUCKET		320 x 530 x 445 (12 9/16 x 20 13/16 x 17 1/2)		
NET WEIGHT, kg(lbs)			21.5(47)	17.2(38)	17.7(39)

NOTE : Specifications are subject to minor change without notice for further improvement.

1.5 CONTROL

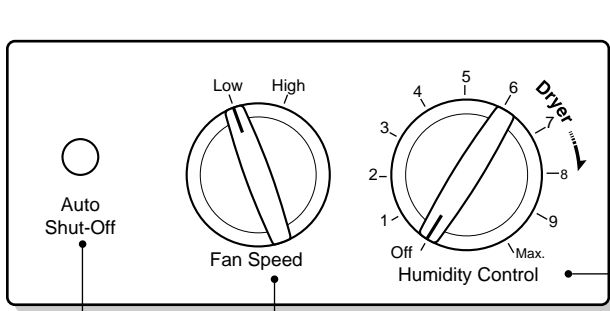

Auto Shut-Off

- Glows when the bucket is ready to be emptied, or when the bucket is removed or not replaced in the proper position.
- The Water Level Control Switch shuts off the dehumidifier when the bucket is full, or when the bucket is removed or not replaced in the proper position.

Humidity Control

- When you first use the dehumidifier, turn the humidity control to **5** or **6**. If you still have moisture, turn the humidity control to a higher setting. **MAX** is the highest setting.
- When excess moisture and dampness odors are gone, adjust the control to a lower setting. Use the dehumidifier as long as excess moisture is present.

Fan Speed

- The fan control adjusts the fan speed. Set the fan control to **HIGH** for maximum moisture removal. When the humidity has been reduced and quiet operation is preferred, set the fan control to **LOW**.

1.6 HOW TO OPERATE DEHUMIDIFIER

1.6.1 HOW DOES THE DEHUMIDIFIER WORK?

Moist, humid air is drawn over a cold refrigerated dehumidifying coil. Moisture in the air condenses on this coil and drains into a bucket (or through the bucket into a hose and drain).

Dry, clean air is drawn over the condenser where it is actually heated several degrees and discharged out the front grille into the room.

It is normal for the surrounding air to become slightly warmer as the dehumidifier operates.

This warming effect further reduces the relative humidity of the surrounding air.

1.6.2 LOCATION FOR THE DEHUMIDIFIER

Allow at least 12 inches of space on all sides of the unit for good air circulation.

■ *The dehumidifier must be operated in an enclosed area to be most effective.*

■ *Close all doors, windows and other outside openings to the room.*

Place the dehumidifier in a location that does not restrict air flow into the rear coil or out the front grille.

A dehumidifier operating in a basement will have little or no effect in drying an adjacent enclosed storage area, such as a closet, unless there is adequate circulation of air in and out of the area.

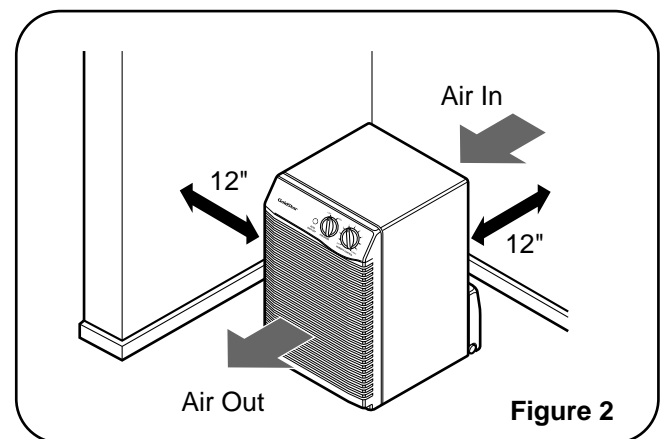
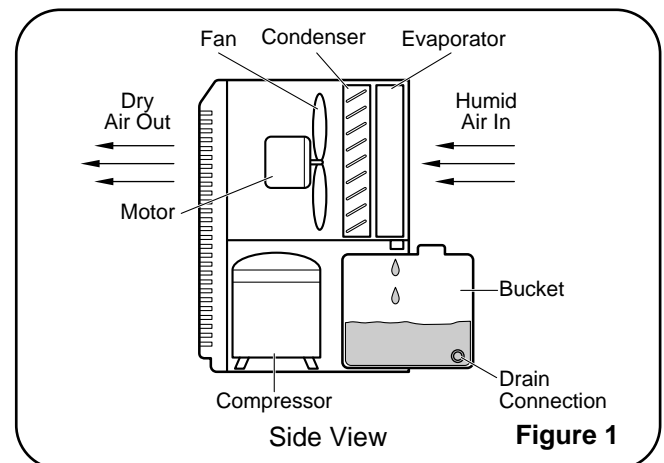

1.6.3 MICRO SWITCH

The micro switch assembly, which is located on the barrier of inside unit, automatically shuts off the dehumidifier when the bucket is full (note, the Auto Shut Off lights, to indicate bucket must be emptied). The bucket replaces in its place, the unit again turns itself on.

1.6.4 AUTO DEFROST

When frost builds up on the cooling coils, the compressor will cycle off until the frost disappears. The fan continues to run.

NOTE: This unit is designed to be operated at temperatures above 65°F(18°C). If the dehumidifier is operated in low temperature conditions, the temperature and humidity conditions of room are low, some frost can be formed in its evaporator coil and the unit will be operated ON/OFF repeatedly. In this case, please check on your room temperature condition and stop the unit.

1.6.5 HUMIDISTAT

Humidistat controls constant relative humidity in the room automatically.

When the relative humidity in the room increases to the selected level, the dehumidifier starts automatically. And the relative humidity drops to the selected level, the dehumidifier stops automatically.

When the first using the dehumidifier, it is recommended, for the first three or four days, to operate the unit with the humidistat control set to MAX. At this setting, the unit will run continuously.

When the sweating has stopped and the dampness odors have gone, it is preferable to select the humidistat position that will best suit local conditions.

The relative humidity range it can control is from 20 % to 80%. (See Figure 3)

NOTE: The relative humidity at the number is the approximate value.

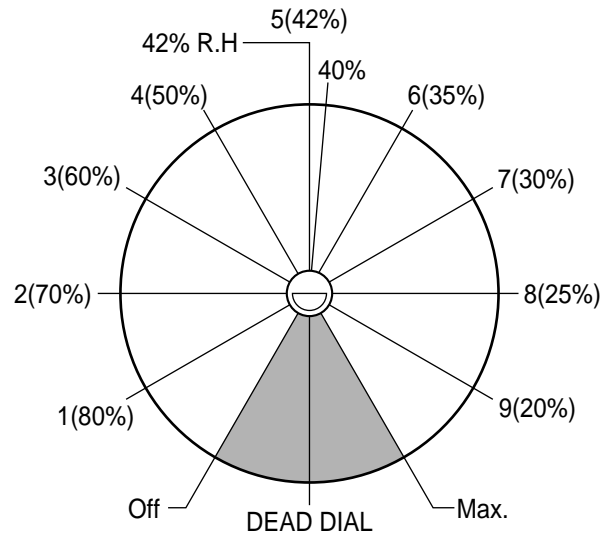

Figure 3

1.6.6 DRIER (For some models)

Dryer is used to prevent capillary blockage from moisture in the refrigerant system and H/E, condenser and evaporator. Also, dryer is used to remove corrosion of the components.

NOTE: When dryer is replaced, proper injection to capillary is needed. On opening the dryer, it should be welded instantly. The oxidization of dryer inside and all tubes inside after welding can be prevented.

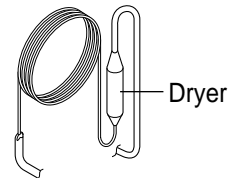
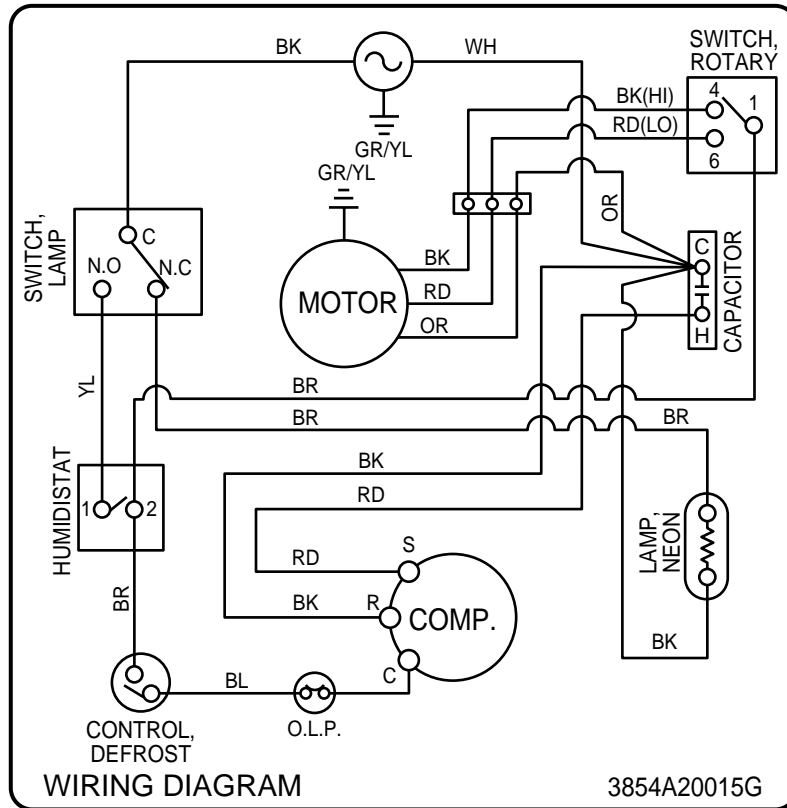

Figure 4

• MODEL : DH4010B/DHA4012DL, DH5010B/DHA5012DL(DEFROST CONTROL TYPE)



LOCATION NO.	DESCRIPTION	PART NO.		Q'TY PER SET	RE-MARKS
		DH4010B	DH5010B		
1	POWER CORD ASSEMBLY	6411A20001Q		1	S, A
2	SWITCH, ROTARY	6600A20001A		1	S
3	MOTOR ASSEMBLY SINGLE	4681A20040A		1	S
4	CAPACITOR	0CZZA20001Q		1	S
5	COMPRESSOR (ROTARY)	2520UABC2FA	5416AR2179J	1	S
6	O.L.P.	6750U-L039A		1	S
7	LAMP, NEON	6912A30001F		1	S
8	CONTROL, DEFROST	-	6614A30001F	1	S
9	HUMIDISTAT	5216A20001A		1	S, A
10	SWITCH ASSEMBLY, MICRO	6600A30003C		1	S

S: SERVICE PARTS A: ALTERNATE PARTS N: NOT SERVICE PARTS

• MODEL : DH4010B/DHA4012DL, DH5010B/DHA5012DL(THERMOSTAT CONTROL TYPE)

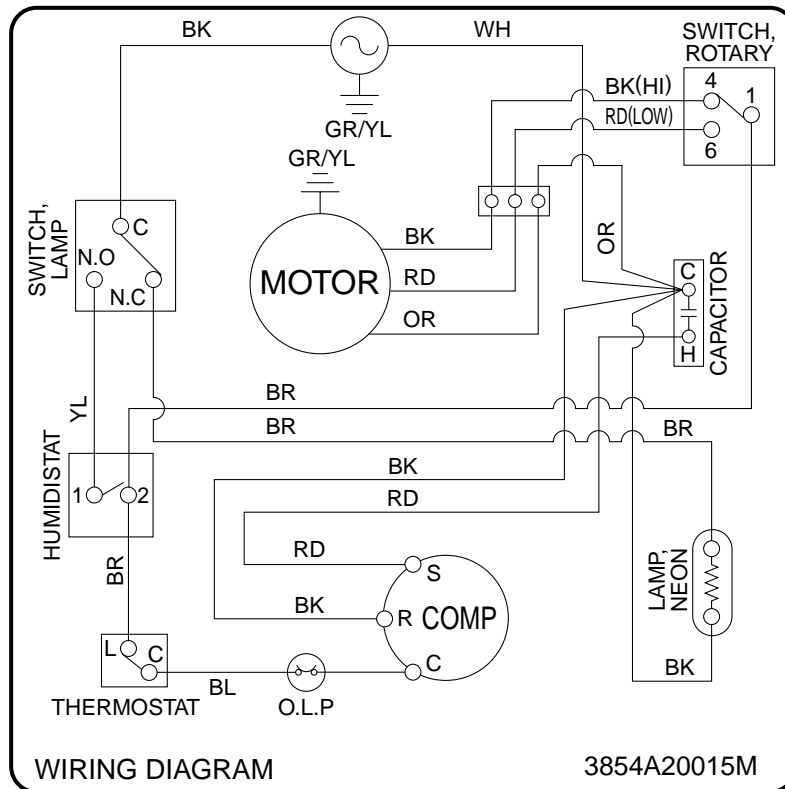

LOCATION NO.	DESCRIPTION	PART NO.		Q'TY PER SET	RE-MARKS
		DH4010B	DH5010B		
1	POWER CORD ASSEMBLY	6411A20001Q		1	S, A
2	SWITCH, ROTARY	6600A20001A		1	S
3	MOTOR ASSEMBLY SINGLE	4681A20040A		1	S
4	CAPACITOR	0CZZA20001Q		1	S
5	COMPRESSOR (ROTARY)	2520UABC2FA	5416AR2179J	1	S
6	O.L.P.	6750U-L039A		1	S
7	LAMP, NEON	6912A30001F		1	S
8	THERMOSTAT	2H01127K	2H01127J	1	S
9	HUMIDISTAT	5216A20001A		1	S, A
10	SWITCH ASSEMBLY, MICRO	6600A30003C		1	S

S: SERVICE PARTS A: ALTERNATE PARTS N: NOT SERVICE PARTS

3. DISASSEMBLY INSTRUCTIONS

3.1 MECHANICAL PARTS

3.1.1 BUCKET AND AIR FILTER

1. Disconnect the power supply.
2. Turn the Humidity Control off.
3. Remove the bucket. (See Figure 5)
4. Flex the filter at the lower right corner and take it off. (See Figure 5)

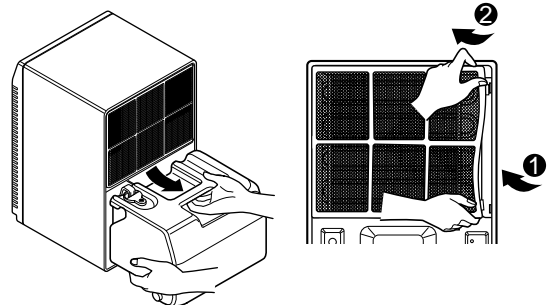

Figure 5

3.1.2 FRONT GRILLE

1. Remove 2 screws which fasten the front grille.
2. By pushing the both sides of front grille, pull the front grille forward and upward. (See Figure 6)

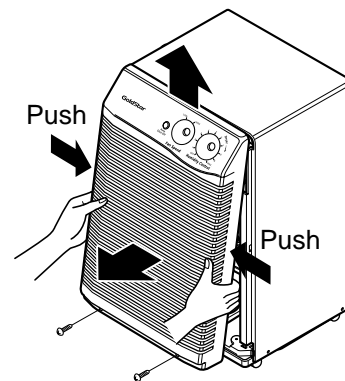

Figure 6

3.1.3. CABINET AND CONTROL BOX

1. Remove the Bucket, the Air filter and Front grille according to the procedure above.
2. Remove 3 screws that fasten Control box. (See Figure 7)
3. Remove 9 screws on all sides of the cabinet.
4. Lift the Cabinet from the base.(See Figure 8)
5. Remove a screw fasten the earth wire on the front of control box.
6. Unhook control box from two hooks on the shroud. (See Figure 8)

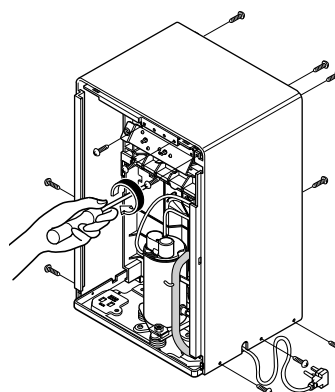

Figure 7

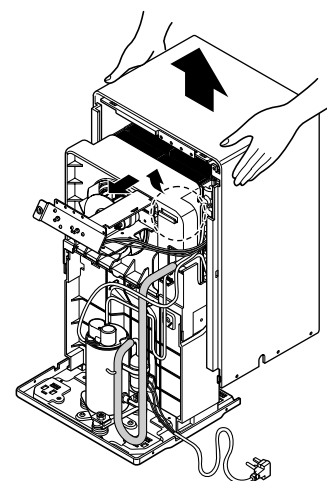

Figure 8

3.2 CONTROL PARTS

3.2.1 ROTARY SWITCH, HUMIDISAT AND NEON LAMP

1. Unfasten screws located in the bottom side of control box (see Figure 9) and fasten capacitor clamp. (DH5010B/DH4010B) And then unfold two sides of control box. (See Figure 9)
2. Disconnect housing and all leads of rotary switch, humidistat and neon lamp.
3. Remove 4 screws which fasten the rotary switch and humidistat.
4. Pull the neon lamp out.

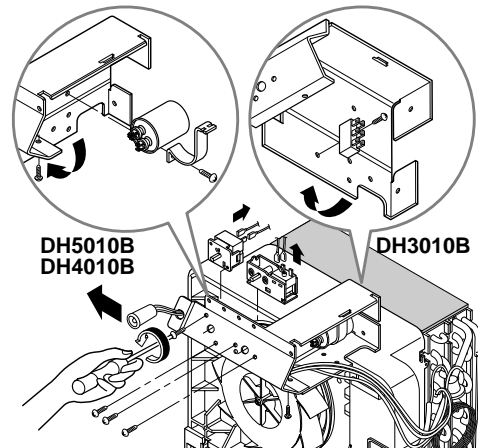

Figure 9

3.2.2 CAPACITOR

1. Remove each screw that fastens capacitor after control box is stretched upper wand. (See Fig. 9)
2. Disconnect all leads of capacitor then remove them from control box.

3.2.3 DEFROST CONTROL (Some Models)

1. Disconnect all leads of the defrost control in the Control Box.
2. Remove the defrost control from the suction tube. (See Figure 10)

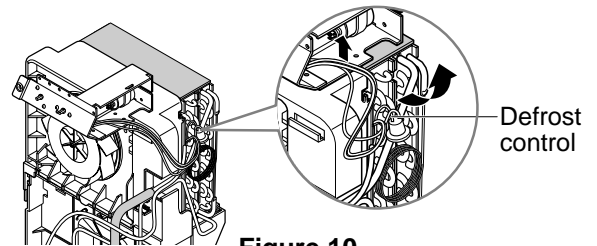

Figure 10

3.2.4 THERMOSTAT CONTROL (Some Models)

1. Disconnect all leads of the thermostat on the control box.
2. Remove the capacitor in the control box. (some models)
3. Remove two screws that fasten the thermostat from the control box. (See figure 11)

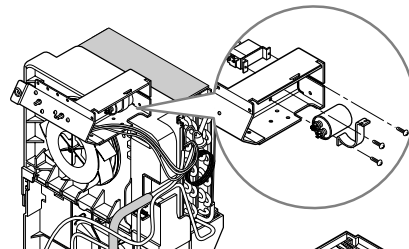

Figure 11

3.2.5 MICRO SWITCH ASSY

1. Disconnect the housing with three leads connected in the Micro switch.
2. Turn the nut left and take off the micro switch from the barrier. (See Figure 12)

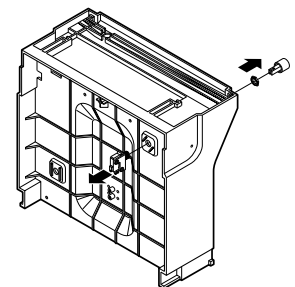

Figure 12

3.2.6 POWER CORD ASSY

1. After the control box opens, remove a screw that fastens the earth wire of the Power cord.
2. Disconnect housing and all leads of power cord then remove it from the unit. (See Figure 13)

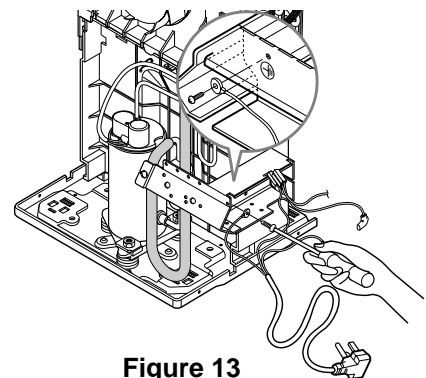

Figure 13

3.2.7 FAN AND MOTOR

1. Turn the nut left and pull out the Fan by hands carefully.
2. Remove 2 screws that fasten Heat Exchange.
3. Lift the H/E and open the H/E around 45 degree clockwise carefully. (See Figure 14)
4. Unfasten 3 screws that secure the Motor and earth wire. (See Figure 15)
5. Remove the Motor.

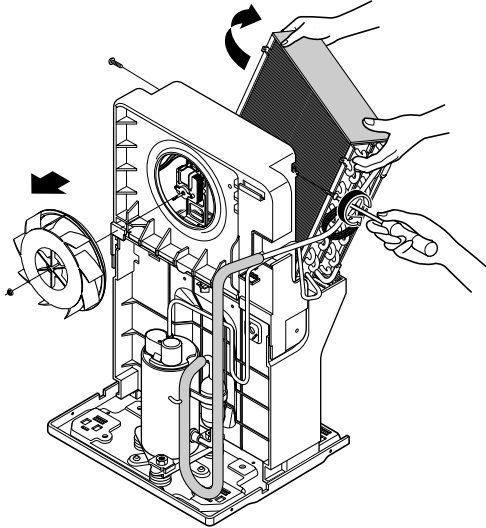

Figure 14

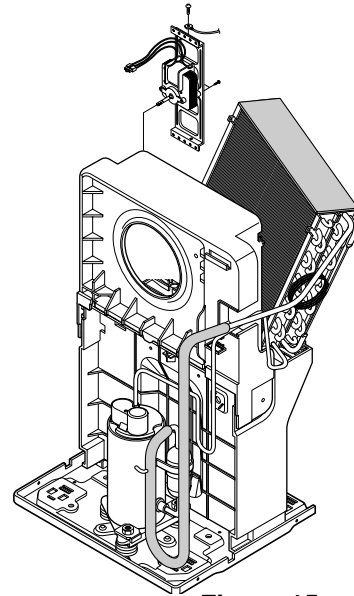

Figure 15

3.2.8 SHROUD AND BARRIER

1. Discharge the refrigerant by using a refrigerant Recovery System.
2. After purging the unit completely, unbrace the Discharge and the Suction tube connected compressor carefully.
3. Remove 2 screws that fasten the H/E.
4. Unfasten 3 screws that secure the shroud on back and sides and upward the shroud from Barrier.
5. Unfasten 2 screws that secure the Barrier to base pan.
6. Pull the Barrier backward then take it up from the base.

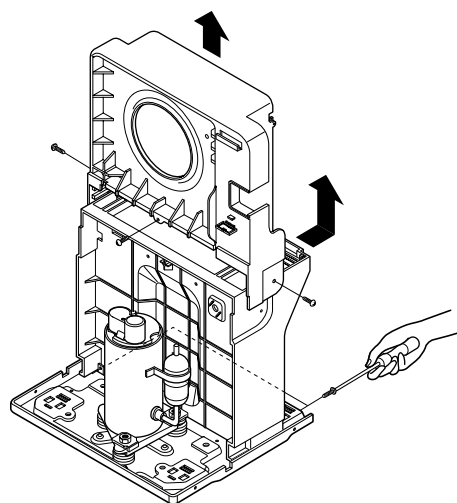
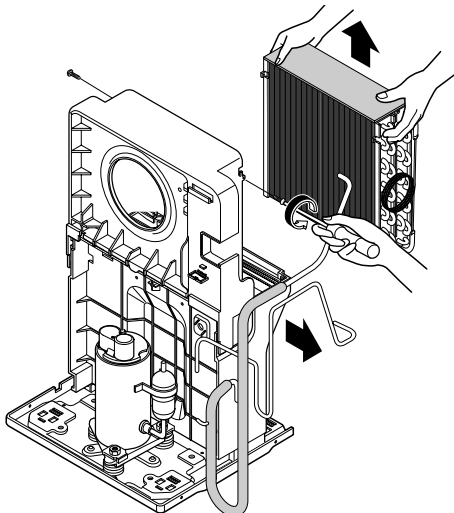

Figure 16

3.3 REFRIGERATING CYCLE

3.3.1 CONDENSER, EVAPORATOR AND CAPILLARY TUBE(HEAT EXCHANGE ASSEMBLY)

1. Remove the insulation on the H/E assembly
2. Pierce the pinch-off tube to discharge the refrigerant, using a FREON™ recovery system.
3. After discharging the refrigerant completely, remove 2 screws between the shroud and H/E. (See Figure 17)
4. Lift the H/E and open the H/E around 45 degree clockwise carefully.
5. Unbrace two interconnecting tubes of the evaporator and condenser carefully.
6. Remove the H/E assembly from the shroud. (See Figure 18)
7. Unbrace the capillary tube at the connections of each condenser and evaporator. (See Figure 19)
8. Remove 4 screws between condenser and evaporator. (See Figure 19)

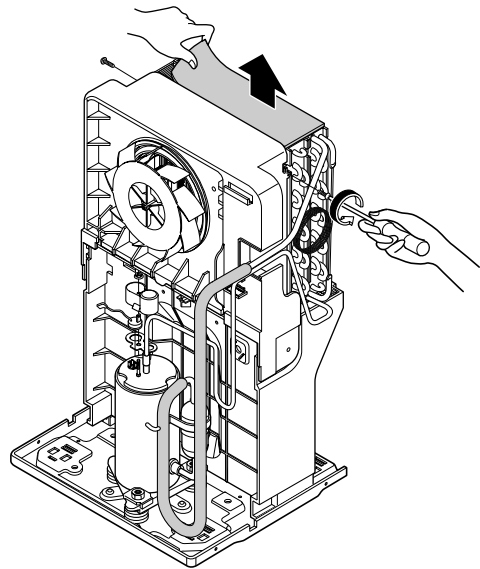

Figure 17

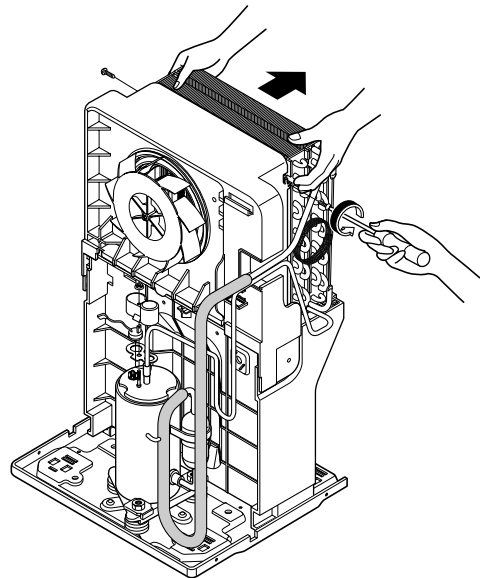

Figure 18

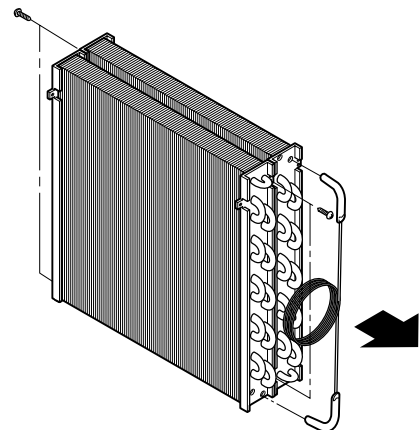
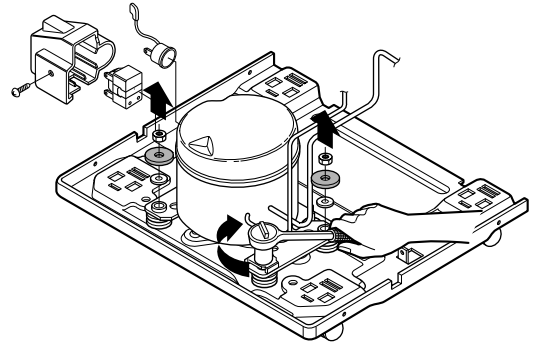

Figure 19

3.3.2 P.T.C. OR OVERLOAD PROTECTOR (O.L.P.) FOR RECIPROCATING COMPRESSOR

1. Remove the cabinet. (Refer to section 3.1.3)
2. Remove a screw or a nut which fastens the terminal cover
3. Disconnect the lead wire from the overload protector or P.T.C. assembly.
4. Remove the overload protector(O.L.P) or P.T.C. assembly. (See Figure 20)



Using Recipro Compressor model

Figure 20

3.3.3 ROTARY COMPRESSOR

1. Remove the cabinet. (Refer to section 3.1.3)
2. Discharge the refrigerant by using a refrigerant Recovery System.
3. After purging the unit completely, unbrace the suction and discharge tubes at the compressor connections.
4. Remove the nuts and washers which fasten the compressor. (See Figure 21)
5. Remove the compressor. (See Figure 21)

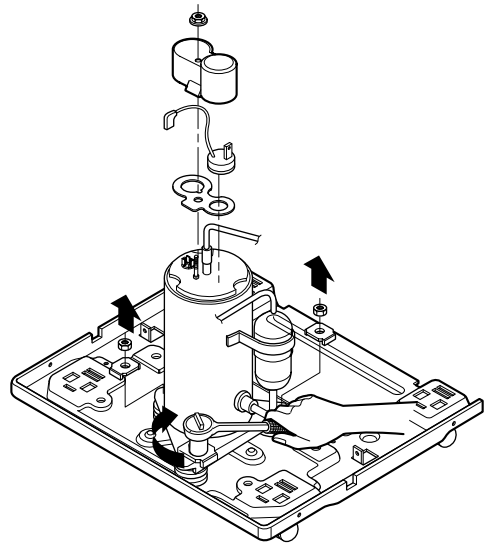

Using Rotary Compressor models

Figure 21

3.4 HOW TO REPLACE THE REFRIGERATION SYSTEM

1. When replacing the refrigeration cycle, be sure to discharge the refrigerant system by using a refrigerant recovery system.
2. After discharging the unit completely, remove the desired component, and unbrace the pinch-off tubes.
3. Solder service valves into the pinch-off tube ports, leaving the valves open.
4. Solder the pinch-off tubes with service valves.
5. After doing the above procedures, the valve must be closed and left in place on the system for any subsequent procedures.
6. Evacuate as follows.
 - 1) Connect the vacuum pump, as illustrated in Figure 22A.
 - 2) Start the vacuum pump, slowly open manifold valves A and B with two full turns counterclockwise and leave the valves closed. The vacuum pump is now pulling through valves A and B up to valve C by means of the manifold and entire system.
7. Recharge as follows :
 - 1) Refrigeration cycle systems are charged from the High-side. If the total charge cannot be put in the High-side, the balance will be put in the suction line through the access valve which you installed as the system was opened.
 - 2) Connect the charging cylinder as shown in Figure 22B. With valve C open, discharge the hose at the manifold connection.
 - 3) Open valve A and allow the proper charge to enter the system. Valve B is still closed.
 - 4) If more charge is required, the high-side will not take it. Close valve A.
 - 5) With the unit running, open valve B and add the balance of the charge.
 - a. Do not add the liquid refrigerant to the Low-side.
 - b. Watch the Low-side gauge; allow pressure to rise to 30 lbs.
 - c. Turn off valve B and allow pressure to drop.
 - d. Repeat steps B and C until the balance of the charge is in the system.
 - 6) When satisfied the unit is operating correctly, use the pinch-off tool with the unit still running and clamp on to the pinch-off tube. Using a tube cutter, cut the pinch-off tube about 2 inches from the pinch-off tool. Use sil-fos solder and solder pinch-off tube closed. Turn off the unit, allow it to set for a while, and then test the leakage of the pinch-off connection.

CAUTION

If high vacuum equipment is used, just crack valves A and B for a few minutes, then open slowly with the two full turns counterclockwise. This will keep oil from foaming and being drawn into the vacuum pump.

- 3) Operate the vacuum pump for 20 to 30 minutes, until 600 microns of vacuum are obtained. Close valves A and B, and observe vacuum gauge for a few minutes. A rise in pressure would indicate a possible leak or moisture remaining in the system. With valves A and B closed, stop the vacuum pump.
- 4) Remove the hose from the vacuum pump and place it on the charging cylinder. See Figure 22B. Open valve C. Discharge the line at the manifold connection.
- 5) The system is now ready for final charging.

NOTE: THE REFRIGERANT R134a IS USED SOME MODELS. CHECK THE SPECIFICATION LABEL ON THE CABINET.

When discharging refrigerant R134a, purging instrument should be used only for R134a, without mixing that of refrigerant R22.

When checking the leakage of refrigerant R134a, leakage test tool should be used only for R134a.

The pump for discharging should be high efficiency. Final discharging value must be managed below 0.5 Torr.

Maximum water should be less than quantity 150mg in the cycle-all tubes and H/E assembly-system. If water quantity is over 150mg, it causes acid or corrosion in the cycle system and the capillary tube to be clogged by water and harmful materials.

The model charged the refrigerant R134a should be used dryer to prevent water from overflowing.

Equipment needed: Vacuum pump, charging cylinder, manifold gauge, brazing equipment, pinch-off tool capable of making a vapor-proof seal, leak detector, tubing cutter, hand tools to remove components, service valve.

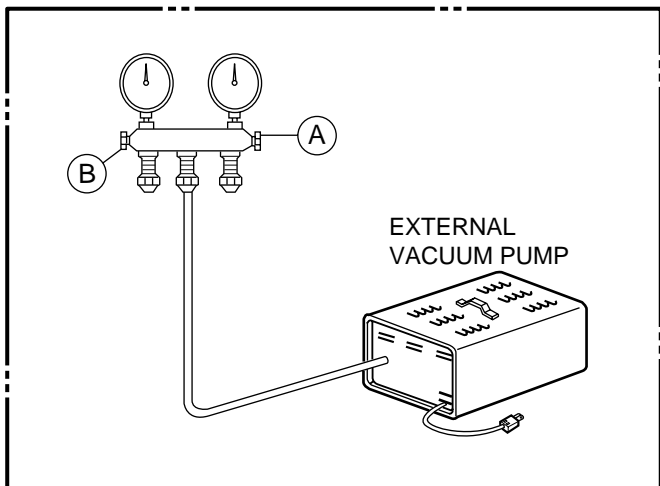
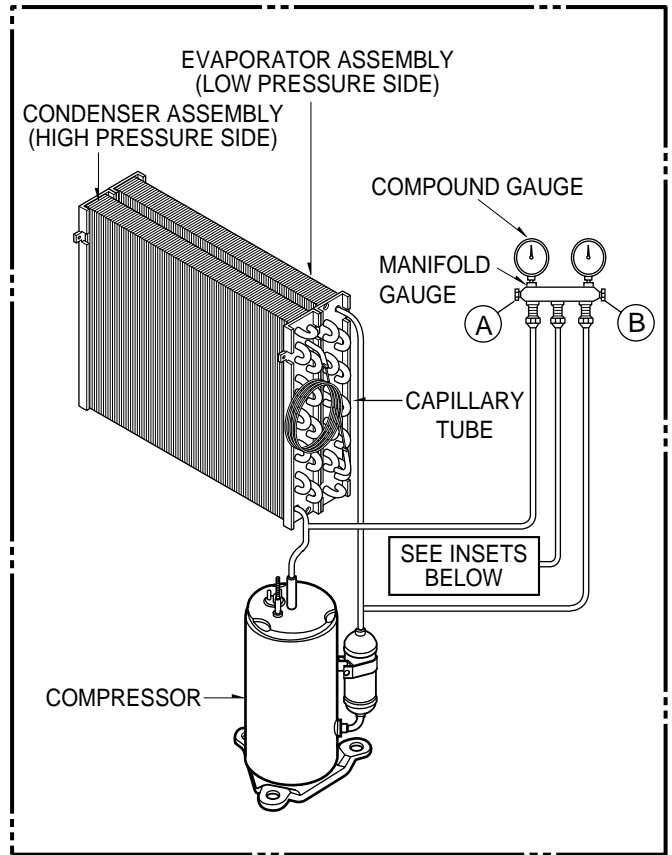
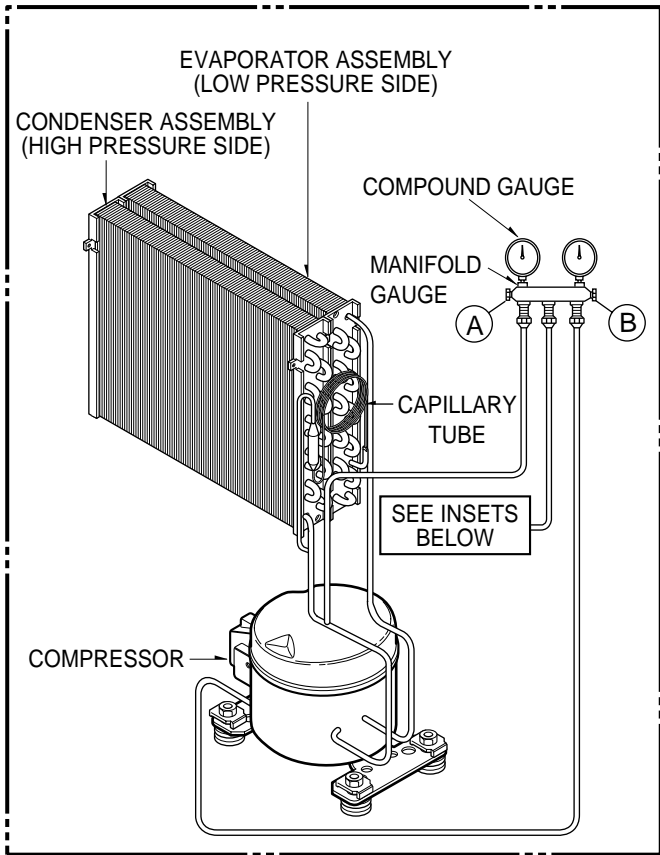

Figure 22A-Pulling Vacuum

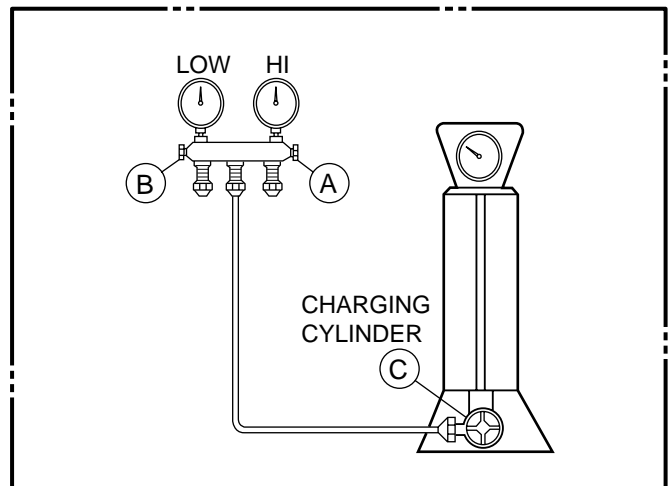

Figure 22B-Charging

4. TROUBLESHOOTING GUIDE

<u>Problem</u>	<u>Possible Causes</u>	<u>Remedy</u>
Dehumidifier does not start.	The dehumidifier is unplugged.	Make sure the dehumidifier's plug is pushed completely into the outlet.
	The fuse is blown/circuit breaker is tripped.	Check the house fuse/circuit breaker box and replace the fuse or reset the breaker.
	Water has reached its preset level.	Empty the bucket and replace properly.
	Bucket is not in the proper position and light is on.	Make sure the slots on both sides of the bucket are positioned correctly.
	Check if wiring loose or fails.	Replace wiring.
Dehumidifier does not dry the air as it should.	The control may not be set high enough.	Turn the Humidity Control knob to a higher number.
	Room temperature is too low.	Moisture removal is best at higher room temperatures. Lower room temperatures will reduce the moisture removal rate. This unit is designed to be operated at temperatures above 65°F (18°C)
	Airflow is restricted.	Make sure there are no curtains, blinds or furniture blocking the front or back of the dehumidifier.
	Doors and windows may not be closed tightly.	Check that all doors, windows and other openings are securely closed.
	Clothes dryer may be blowing moisture-laden air into the room.	Install the dehumidifier away from the dryer. The dryer should be vented to the outside.
Ineffective dehumidifying	Check for gas leakage at heat exchange and connecting tube.	Repair gas leak.
	Check if the air filter are clogged with dust.	Clean the air filter.
Noise	Check if the unit is securely positioned.	Set and use the dehumidifier at a sturdy, flat, and level place.

CONDITION	CAUSE	REMEDY
1. Dehumidifier does not start. (Both compressor and fan motor do not operate.)	No power	Check power supply at outlet. Correct if none.
	Poor plug contact at outlet.	Install plug properly or replace it.
	Bucket is full.	If Auto Shut Off lights, empty the bucket and replace properly.
	Humidity control is at Off position	Turn the humidity control switch toward Max.
	Wire disconnect or loose	Connect wire. Refer to wiring diagram for terminal identification. Repair or replace loose terminal.
	Capacitor. (Discharge capacitor before testing.)	Test capacitor. Replace if not within $\pm 10\%$ of manufacturer's rating. Replace if shorted, open, or damaged.
2. Motor runs but compressor does not run.	Voltage (115V \pm 10%)	It must be between 103.5V and 126.5V. If not within limits, call an electrician
	Wiring	Check the wire connections; If loose, repair or replace the terminal. If the wires are disconnected, refer to wiring diagram for identification, and replace the wires. Check the wire connections; If not according to the wiring diagram, correct the connections.
	Rotary switch	Check for continuity, refer to the wiring diagram for terminal identification. Replace the switch if the circuit is open.
	Defrost control	The Defrost Control senses frost build-up on the evaporator coil and automatically shuts off the compressor. The fan continues to run, drawing air across the coil, and melting the frost. When the coil is defrosted, the compressor automatically restarts, and dehumidifying resumes.
	Capacitor (Discharge capacitor before servicing.)	Check the capacitor. Replace if not within $\pm 10\%$ of manufacturer's rating. Replace if shorted, open, or damaged.
	Compressor	Check the compressor for open circuit or ground. If open or grounded, replace the compressor.
	Overload protector (O.L.P.)	Check the compressor O.L.P. if externally mounted. Replace if open. (If the compressor temperature is high, remove O.L.P., cool, and retest.)
3. Does not defrost control.	Defrost control is defective.	Check defrost control, replace it.
4. Insufficient dehumidification	Low relative humidity	Turn dehumidifier off.
	Poor air circulation	Move dehumidifier to obtain free and unobstructed air circulation.
	H/E clogged with dust and dirt	Clean evaporator and/or condenser assembly
	Air filter is dirty.	Clean it.
	Motor is not operating.	Check Motor, repair or replace it.

CONDITION	CAUSE	REMEDY
5. Noisy operating	Fan	If cracked, out of balance, or partially missing, replace it
	Some material plunged and rattle.	Remove it.
	Tube hits frame.	Adjust tubing routine carefully.
	Fan blade hits frame	Check Motor Mount. If loose, tighten it.
	Internal compressor noise.	Replace compressor.
	Loose set screws	Tighten them.
	Worn bearings of Motor Assembly	If knocking sounds continue when running or loose, replace the motor. If the motor hums or noise appears to be internal while running, replace motor assembly.
6. Water drips	The bucket is not installed properly.	The bucket should be properly positioned on the hangers of the drain pan.
	Connection may be loose.	Check connection and repair.
	Leak in bucket	Replace bucket.
	Water drips when bucket removed for emptying.	Before removing bucket, the unit should be turned off.
	Bucket overflows.	Check micro switch and float.
7. Compressor cycles on overload protector. (O.L.P.)	High or low line voltage. (115V ± 10%)	Check line voltage. It must be between 103.5V and 126.5V volts. If intermittent, provide new supply.
	Poor air circulation.	Move dehumidifier for free and unobstructed air flow.
	Heat Exchange clogged with dust or dirt.	Clean dust or dirt on the Heat Exchange.
	Motor	If not running, determine the cause. Replace if required.
	Bad P.T.C. assembly (if assembled)	Check P.T.C., Repair.
	Short circuit or ground in electrical circuit	Check electrical circuit. Repair.
	Unit pressures not equalized	Allow 2 or 3 minutes for pressure to equalize before starting compressor.
	Capacitor	Test the capacitor.
	Wiring	Check the terminals. If loose, repair or replace.
	Refrigeration system	Check the system for a restriction.
	Stuck compressor	Check compressor, replace compressor
	Overload protector (O.L.P.)	Check O.L.P., if externally mounted. Replace if open. (If the compressor temperature is high, remove the O.L.P., cool, and retest.)

5. EXPLODED VIEW - INTRODUCTION

• MODEL: DH3010B/DHA3012DL

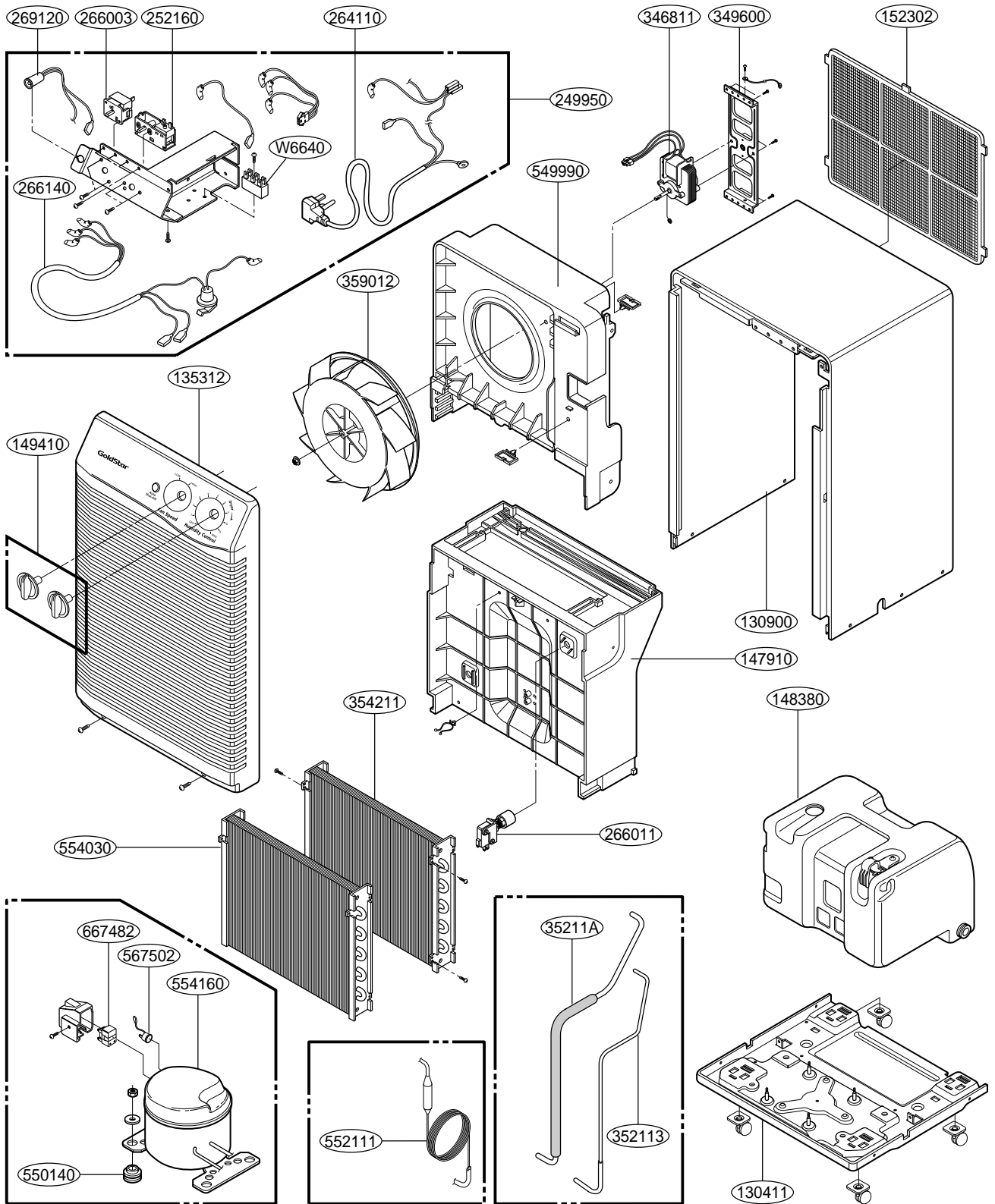

• MODEL: DH4010B/DHA4012DL, DH5010B/DHA5012DL(DEFROST CONTROL TYPE)

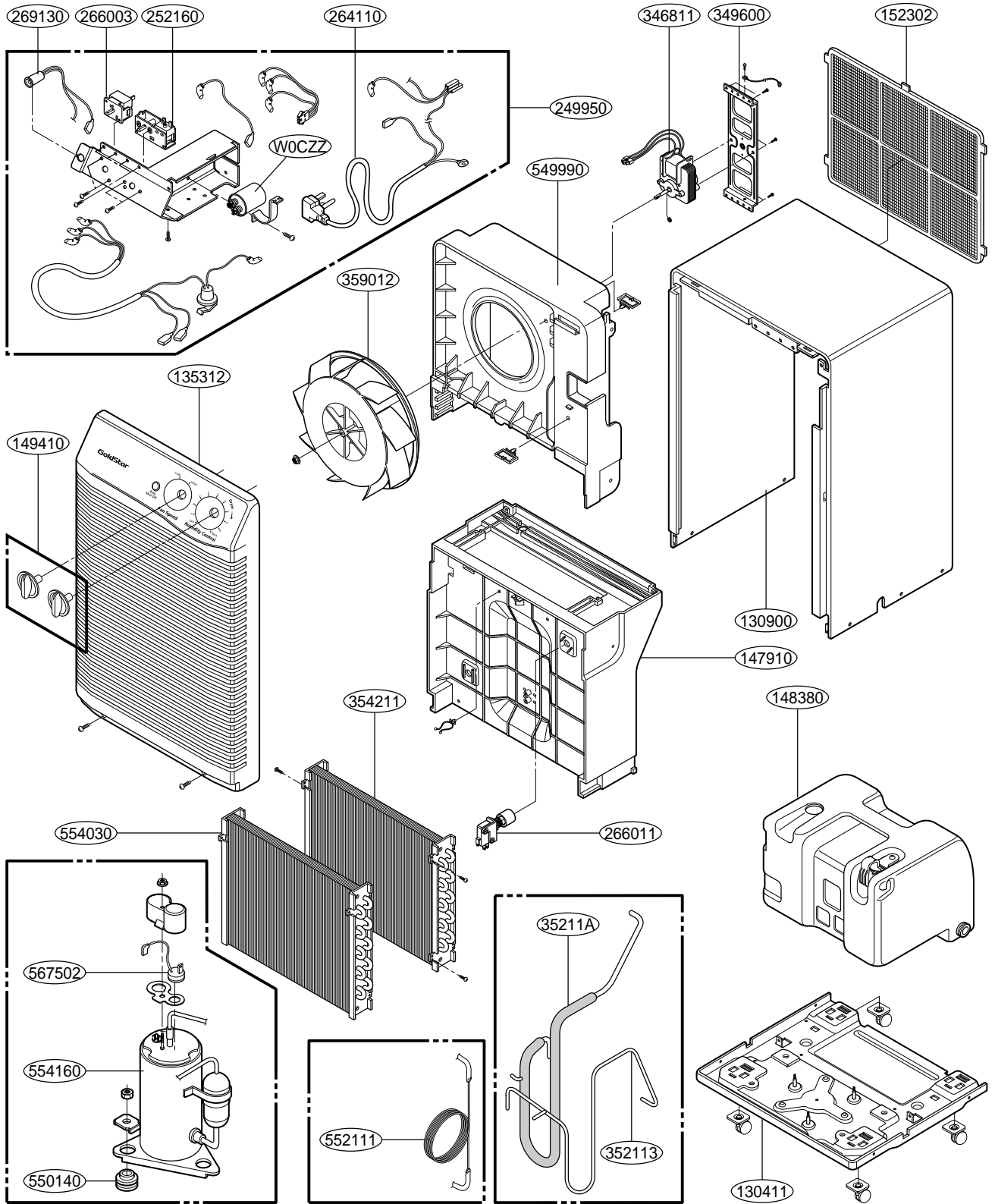

• MODEL: DH4010B/DHA4012DL, DH5010B/DHA5012DL(THERMOSTAT CONTROL

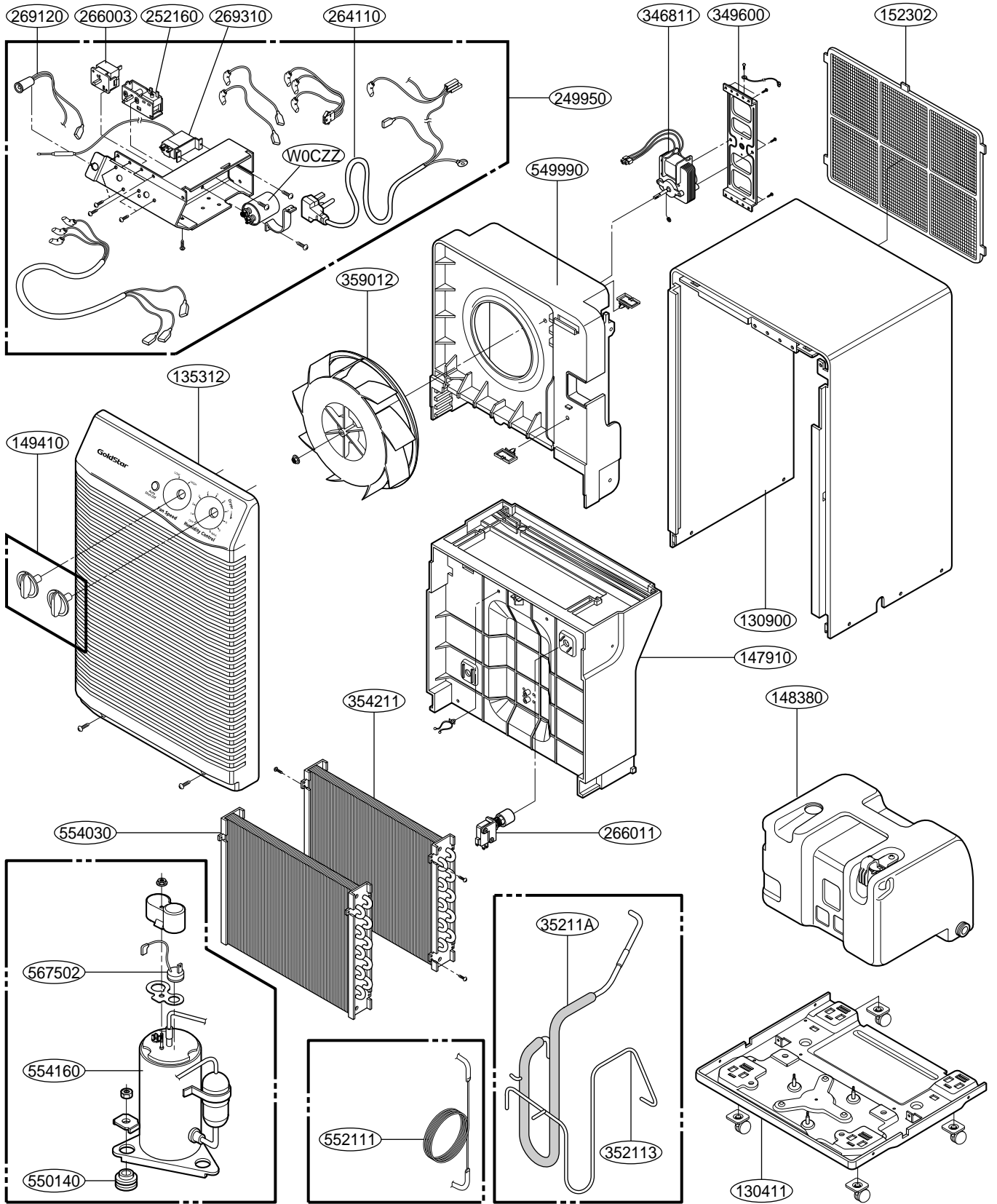

6. REPLACEMENT PARTS LIST

• MODEL: DH3010B, DHA3012DL

LOCATION NO.	DESCRIPTION	PART NO.	REMARK
		DH3010B/DHA3012DL	
130411	BASE ASSY, WELD(SINGLE)	3041AD2007B	
130900	CABINET	3090A10001J	
135312	GILLE ASSY, FRONT	3531A20012B	
147910	BARRIER ASSY	4791A10002B	
148380	TANK, BUCKET	4838A20005A	
149410	KNOB ASSY	4941A30002A	
152302	FILTER(MECH), AIR	5230AD3005A	
249950	CONTROL BOX ASSY	4995A20085F	
W6640	TERMINAL BLOCK	6640A40001A	
264110	POWER CORD ASSY	6411A20001Q	ALT) 6411A20001R
266003	SWITCH, ROTARY	6600A20001A	
252160	HUMIDISTAT	5216A20001A	ALT) 5216A20001B
266011	SWITCH ASSY, MICRO	6600A30003C	
266140	CONTROL DEFROST	6614A30001H	
269120	LAMP, NEON	6912A30001F	
346811	MOTOR ASSY, SINGLE	4681A20040A	
35211A	TUBE ASSY, SUCTION SINGLE	5211A30373B	
352113	TUBE ASSY, DISCHARGE SINGLE	5211A30367A	
354211	EVAPORATOR ASSY	5421A10009B	
549990	SHROUD ASSY	4999A10001A	
550140	ISOLATOR	5040AR4195A	
552111	TUBE ASSY, CAPILLARY	5211A10085C	
554030	CONDENSER ASSY	5403A10008B	
554160	COMPRESSOR ASSY, FINAL	2521C-A8605	
359012	FAN, TURBO	5900A20007A	
567502	O.L.P	6750C-0002S	
349600	MOUNT, MOTOR	4960A20009A	
667482	P.T.C	6748C-0003A	

• MODEL: DH4010B/DHA4012DL, DH5010B/DHA5012DL(DEFROST CONTROL TYPE)

LOCATION NO.	DESCRIPTION	PART NO.		REMARK
		DH4010B/DHA4012DL	DH5010B/DHA5012DL	
130411	BASE ASSY, WELD(SINGLE)	3041AD2007C		
130900	CABINET	3090A10001J		
135312	GILLE ASSY, FRONT	3531A20012B		
147910	BARRIER ASSY	4791A10002A		ALT)4791A10002B
148380	TANK, BUCKET	4838A20005A		
149410	KNOB ASSY	4941A30002A		
152302	FILTER(MECH), AIR	5230AD3005A		
W0CZZ	CAPACITOR	0CZZA20001Q		
249950	CONTROL BOX ASSY	4995A20085E		
264110	POWER CORD ASSY	6411A20001Q		ALT) 6411A20001R
266003	SWITCH, ROTARY	6600A20001A		
252160	HUMIDISTAT	5216A20001A		ALT) 5216A20001B
266011	SWITCH ASSY, MICRO	6600A30003C		
266140	CONTROL DEFROST	-	6614A30001F	
269120	LAMP, NEON	6912A30001F		
346811	MOTOR ASSY, SINGLE	4681A20040A		
35211A	TUBE ASSY, SUCTION SINGLE	5211A10071B	5211A10071A	
352113	TUBE ASSY, DISCHARGE SINGLE	5211A10070C	5211A10070A	
354211	EVAPORATOR ASSY	5421A10009D	5421A10009A	
549990	SHROUD ASSY	4999A10001A		
550140	BUSHING	4830A30005A		
552111	TUBE ASSY, CAPILLARY	5211A10085D	5211A10085A	
554030	CONDENSER ASSY	5403A10008C	5403A10008A	
554160	COMPRESSOR ASSY, FINAL	2520UABC2FA	5416AR2179J	
359012	FAN, TURBO	5900A20007A		
567502	O.L.P	6750U-L039A		
349600	MOUNT, MOTOR	4960A20009A		

• MODEL: DH4010B/DHA4012DL, DH5010B/DHA5012DL(THERMOSTAT CONTROL TYPE)

LOCATION NO.	DESCRIPTION	PART NO.		REMARK
		DH4010B/DHA4012DL	DH5010B/DHA5012DL	
130411	BASE ASSY, WELD(SINGLE)	3041AD2007C		
130900	CABINET	3090A10001J		
135312	GILLE ASSY, FRONT	3531A20012B		
147910	BARRIER ASSY	4791A10002A		ALT)4791A10002B
148380	TANK, BUCKET	4838A20005A		
149410	KNOB ASSY	4941A30002A		
152302	FILTER(MECH), AIR	5230AD3005A		
W0CZZ	CAPACITOR	0CZZA20001Q		
249950	CONTROL BOX ASSY	4995A20085J	4995A20085G	
264110	POWER CORD ASSY	6411A20001Q		ALT) 6411A20001R
266003	SWITCH, ROTARY	6600A20001A		
252160	HUMIDISTAT	5216A20001A		ALT) 5216A20001B
266011	SWITCH ASSY, MICRO	6600A30003C		
269310	THERMOSTAT	2H01127K	2H01127J	
269120	LAMP, NEON	6912A30001F		
346811	MOTOR ASSY, SINGLE	4681A20040A		
35211A	TUBE ASSY, SUCTION SINGLE	5211A10071B	5211A10071A	
352113	TUBE ASSY, DISCHARGE SINGLE	5211A10070C	5211A10070A	
354211	EVAPORATOR ASSY	5421A10009D	5421A10009A	
549990	SHROUD ASSY	4999A10001A		
550140	BUSHING	4830A30005A		
552111	TUBE ASSY, CAPILLARY	5211A10085D	5211A10085A	
554030	CONDENSER ASSY	5403A10008C	5403A10008A	
554160	COMPRESSOR ASSY, FINAL	2520UABC2FA	5416AR2179J	
359012	FAN, TURBO	5900A20007A		
567502	O.L.P	6750U-L039A		
349600	MOUNT, MOTOR	4960A20009A		



P/No : 3828A30039T

March, 2001
Printed in Korea