





website <http://www.lgservice.com>

LG

# LG Room Air Conditioner

## ***SERVICE MANUAL***

**MODELS: LW1800PR**

**LW1800ER**

**LW1800ERZ3**

**LW1500PR**

**LW1500PRY3**

**LWP1830WAL**

**LWP1820PDL**

**LWP1820PEL**

**LWC182PLMM0**

**LWC183PLMD1**

**LWC212PLMM0**

**LW1804ER**

**LW1800PRZ3**

**HBLG1803R**

### **CAUTION**

- BEFORE SERVICING THE UNIT, READ THE SAFETY PRECAUTIONS IN THIS MANUAL.
- ONLY FOR AUTHORIZED SERVICE PERSONNEL.

# TABLE OF CONTENTS

<b>Safety Precautions</b> .....	3
<b>Dimensions</b> .....	5
Outside dimensions .....	5
<b>Product Specifications</b> .....	6
<b>Installation</b> .....	7
Select the Best Location .....	7
Installation Check .....	7
How to Secure the Drain Pipe .....	7
How to Install .....	8
Suggested Tool Requirements .....	9
Cabinet Installation .....	10
<b>Operation</b> .....	12
Function of Controls .....	12
<b>Disassembly</b> .....	16
Mechanical Parts .....	16
Air Handling Parts .....	17
Electrical Parts .....	18
Refrigerating Cycle .....	20
<b>Schematic Diagram</b> .....	23
Electronic Control Device .....	23
Wiring Diagram .....	25
Components Location .....	26
<b>Troubleshooting Guide</b> .....	28
Piping System .....	28
Troubleshooting Guide .....	29
Electrical Parts Troubleshooting Guide .....	31
Electric Parts .....	35
<b>Exploded View</b> .....	41
<b>Replacement Parts List</b> .....	43

# Safety Precautions



To prevent injury to the user or other people and property damage, the following instructions must be followed.

- Incorrect operation due to ignoring instruction will cause harm or damage. The seriousness is classified by the following indications.

**⚠ WARNING** This symbol indicates the possibility of death or serious injury.

**⚠ CAUTION** This symbol indicates the possibility of injury or damage to properties only.

- Meanings of symbols used in this manual are as shown below.

	<b>Be sure not to do.</b>
	<b>Be sure to follow the instruction.</b>

## ⚠ WARNING

### ■ Installation

**Do not use damaged power cord plugs, or a loose socket.**

- There is risk of fire or electric shock.

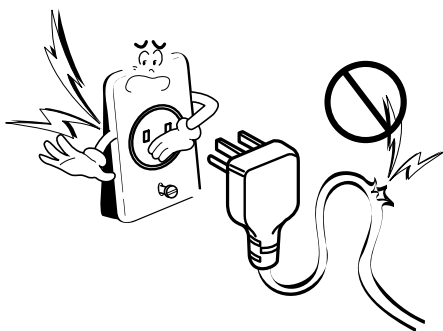

**Always use the power plug and socket with the ground terminal.**

- There is risk of electric shock.

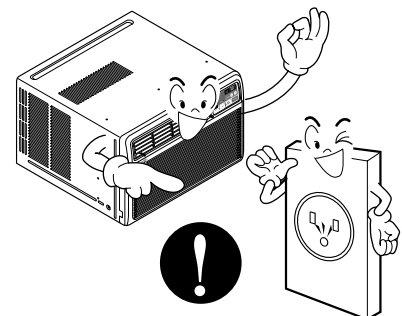

**Do not modify or extend the power cord.**

- There is risk of fire or electric shock.

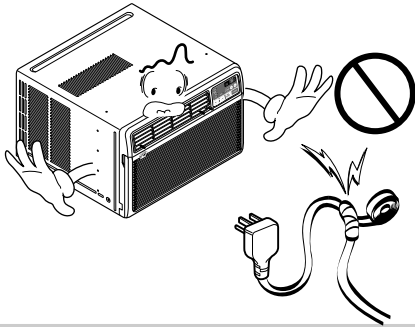

**Do not install, remove, or re-install the unit by yourself(customer).**

- There is risk of fire, electric shock, explosion, or injury.

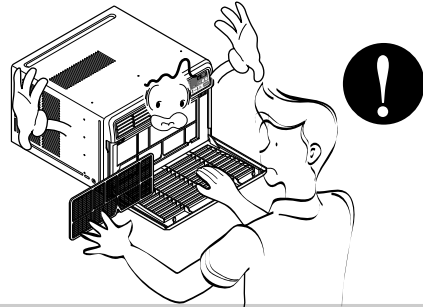

**Be cautious when unpacking and installing the product.**

- Sharp edges could cause injury. Be especially careful of the case edges and the fins on the condenser and evaporator.

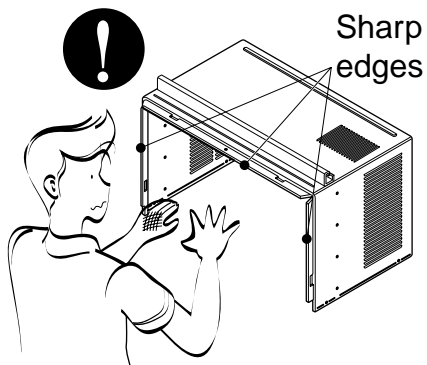

**Do not store or use flammable gas or combustibles near the air conditioner.**

- There is risk of fire or failure of product.

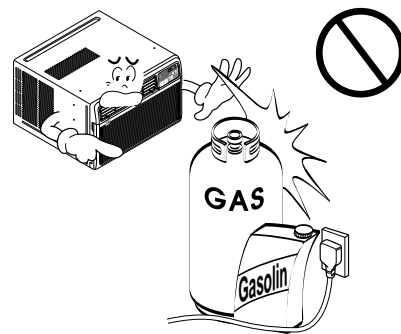

**Be sure the installation area does not deteriorate with age.**

- If the base collapses, the air conditioner could fall with it, causing property damage, product failure, and personal injury.

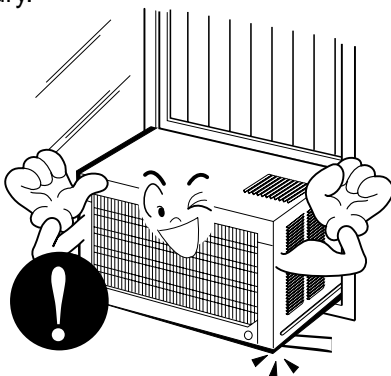

# Dimensions

## Symbols Used in this Manual



This symbol alerts you to the risk of electric shock.



This symbol alerts you to hazards that could cause harm to the air conditioner.

**NOTICE**

This symbol indicates special notes.

## Outside Dimensions

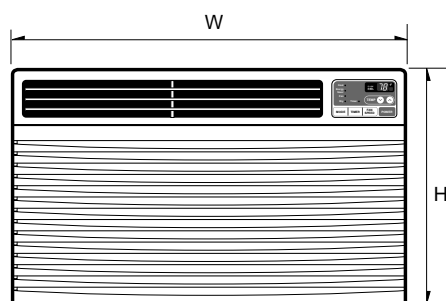
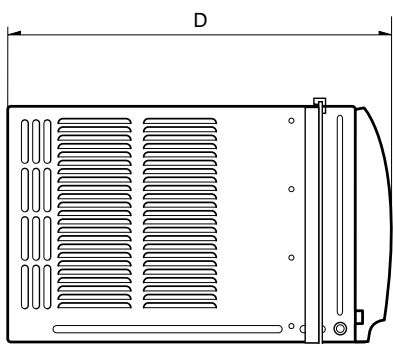

Dimension \ Model		ALL MODELS
W	mm(inch)	660(25 <sup>31</sup> / <sub>32</sub> )
H	mm(inch)	428(16 <sup>27</sup> / <sub>32</sub> )
D	mm(inch)	680(26 <sup>27</sup> / <sub>32</sub> )

# Product Specifications

ITEMS		MODELS		LW1800PR LW1800ER LW1800ERZ3 LW1800PRZ3	LWP1830WAL	LW1500PR LW1500PRY3	LWP1820PDL LWP1820PEL	LWC182PLMM0	LWC212PLMM0	LW1804ER LWC183PLMD1	HBLG1803R
		POWER SUPPLY		1ø, 208/230V, 60Hz		1ø, 115V, 60Hz	1ø, 220V, 60Hz			1ø, 220V, 60Hz	1ø, 208/230V, 60Hz
COOLING	CAPACITY (BTU/h)	18,000		15,000	18,000		24,000	17,500/18,000			
	INPUT (W)	1,670		1,300	1,930	1,890	2,440	1,620/1,670			
	RUNNING CURRENT (A)	7.5	7.8	12	9.0	8.8	11.5	10.8	9.0/8.3		
	E.E.R (BTU/W.h)	10.8		11.5	9.5		9.8	8.0/7.5		9.7/9.7	
HEATING	CAPACITY (BTU/h)	-		18,000	-						
	INPUT (W)	-		1,930	-						
	RUNNING CURRENT (A)	-		9.0	-						
	E.E.R (BTU/W.h)	-		9.5	-						
OPERATING CONDITION	INDOOR (°C)	26.7(DB)*		19.4(WB)**							
	OUTDOOR (°C)	35(DB)*		23.9(WB)**							
REFRIGERANT (R-22) CHARGE		800g(28.2 oz)		670g(23.6 oz)	700g(24.7 oz), 1,070g(37.7 oz)	700g(24.7 oz)	730g(25.7 oz)	765g(27oz)			
EVAPORATOR		3 ROW 11 STACKS, LOUVER-FIN TYPE			2 ROW 11 STACKS, LOUVER-FIN TYPE		3 ROW 11 STACKS, LOUVER-FIN TYPE				
CONDENSER		2 ROW 19 STACKS, L-BENDED TYPE			2 ROW 16 STACKS, L-BENDED TYPE		2 ROW 19 STACKS, L-BENDED TYPE				
FAN, INDOOR		TURBO FAN									
FAN, OUTDOOR		PROPELLER TYPE FAN WITH SLINGER RING									
FAN SPEEDS, FAN/COOLING/HEATING		3/3			3/3, 2/2/2		3/3				
FAN MOTOR		6 POLES									
OPERATION CONTROL		REMOTE CONTROLLER									
ROOM TEMP. CONTROL		THERMISTOR									
AIR DIRECTION CONTROL		VERTICAL LOUVER (RIGHT & LEFT)									
		HORIZONTAL LOUVER (UP & DOWN)									
CONSTRUCTION		SLIDE IN-OUT CHASSIS									
PROTECTOR	COMPRESSOR	OVERLOAD PROTECTOR									
	FAN MOTOR	INTERNAL THERMAL PROTECTOR									
POWER CORD		3 WIRE WITH GROUDING									
		ATTACHMENT PLUG (CORD-CONNECTED TYPE)									
DRAIN SYSTEM		DRAIN PIPE OR SPLASHED BY FAN SLINGER									
NET WEIGHT	(lbs/kg)	115/52		110/50	115/52						
OUTSIDE DIMENSION	(inch)	25 <sup>31</sup> / <sub>32</sub> X 16 <sup>27</sup> / <sub>32</sub> X 26 <sup>27</sup> / <sub>32</sub>									
	(W x H x D)	660 X 428 X 680									

\* DB : dry bulb      \*\* WB : wet bulb

NOTE : Please refer to label quality on the product since this specification may be changed for improving performance.

# Installation

## Select the Best Location

1. To avoid vibration and noise, make sure the unit is installed securely and firmly.
2. Install the unit where the sunlight does not shine directly on the unit.  
If the unit receives direct sunlight, build an awning to shade the cabinet.
3. There should be no obstacle, like a fence, within 20" which might restrict heat radiation from the condenser.
4. To prevent reducing performance, install the unit so that louvers of the cabinet are not blocked.
5. Install the unit a little obliquely outward not to leak the condensed water into the room (about 1/2" or 1/4 bubble with level).
6. Install the unit with its bottom portion 30~60" above the floor level.
7. Stuff the foam between the top of the unit and the wall to prevent air and insects from getting into the room.
8. The power cord must be connected to an independent circuit.  
The green wire must be grounded.
9. Connect the drain tube to the base pan hole in the rear side if you need to drain (consult a dealer).  
Plastic hose or equivalent may be connected to the drain tube.

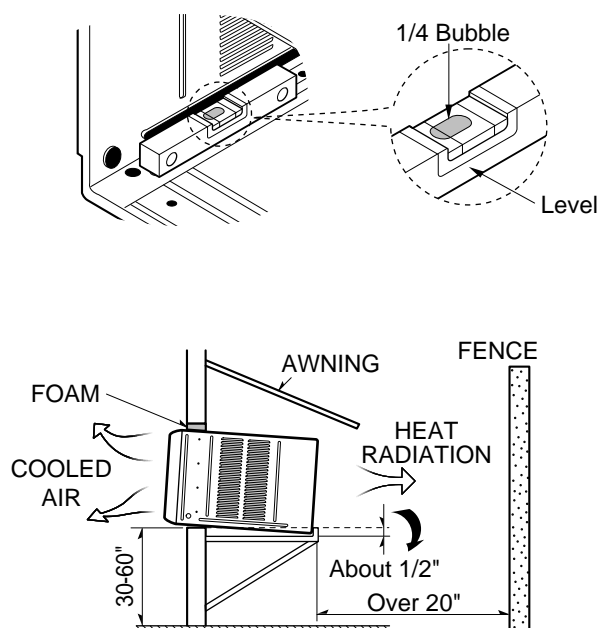

Figure 1

## Installation Check

The setting conditions must be checked prior to initial starting.

The following items are especially important check points when the installation is finished.

1. Grounding wire (Green or Green and Yellow) is provided in the power cord. The green wire must be grounded.
2. Connect to a single-outlet 15A circuit.  
(or 20A circuit for Electric Heater Model)
3. To avoid vibration or noise, make sure the air conditioner is installed securely.
4. Avoid placing furniture or draperies in front of the air inlet and outlet.

## How to Secure the Drain Pipe

In humid weather, excess water may cause the BASE PAN to overflow. To drain the water, remove the DRAIN CAP and secure the DRAIN PIPE to the rear hole of the BASE PAN. Press the drain pipe into the hole by pushing down and away from the fins to avoid injury.

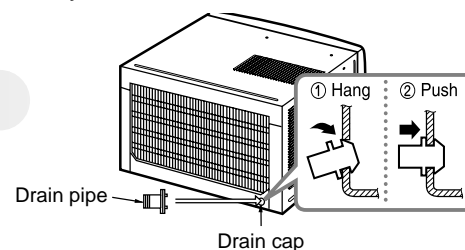

## Optional

1. Install the drain pan over the corner of the cabinet where you removed the plug with 4 (or 2) screws.
2. Connect the drain hose to the outlet located at the bottom of the drain pan. You can purchase the drain hose or tubing locally to satisfy your particular needs. (Drain hose is not supplied).
3. Select the most appropriate connection from among the following figures (by considering the hole of the unit) to fit drain pan to your own unit.

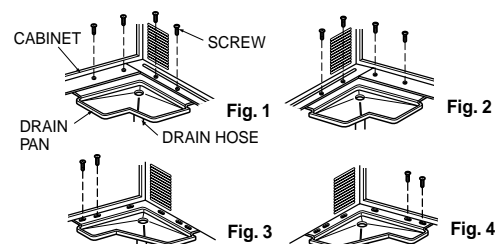

## How to Install

### When Using Installation Kits

#### 1. Window Requirements

This unit is designed for installation in standard double hung windows with actual opening widths from 29" to 41".

The top and bottom window sash must open sufficiently to allow a clear vertical opening of 16" from the bottom of the upper sash to the window stool.

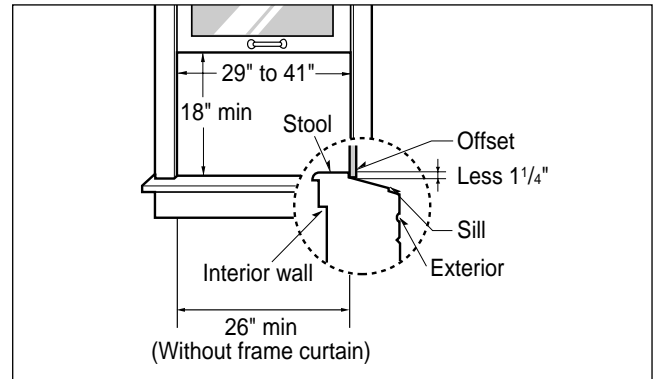

#### 2. Installation Kits Contents

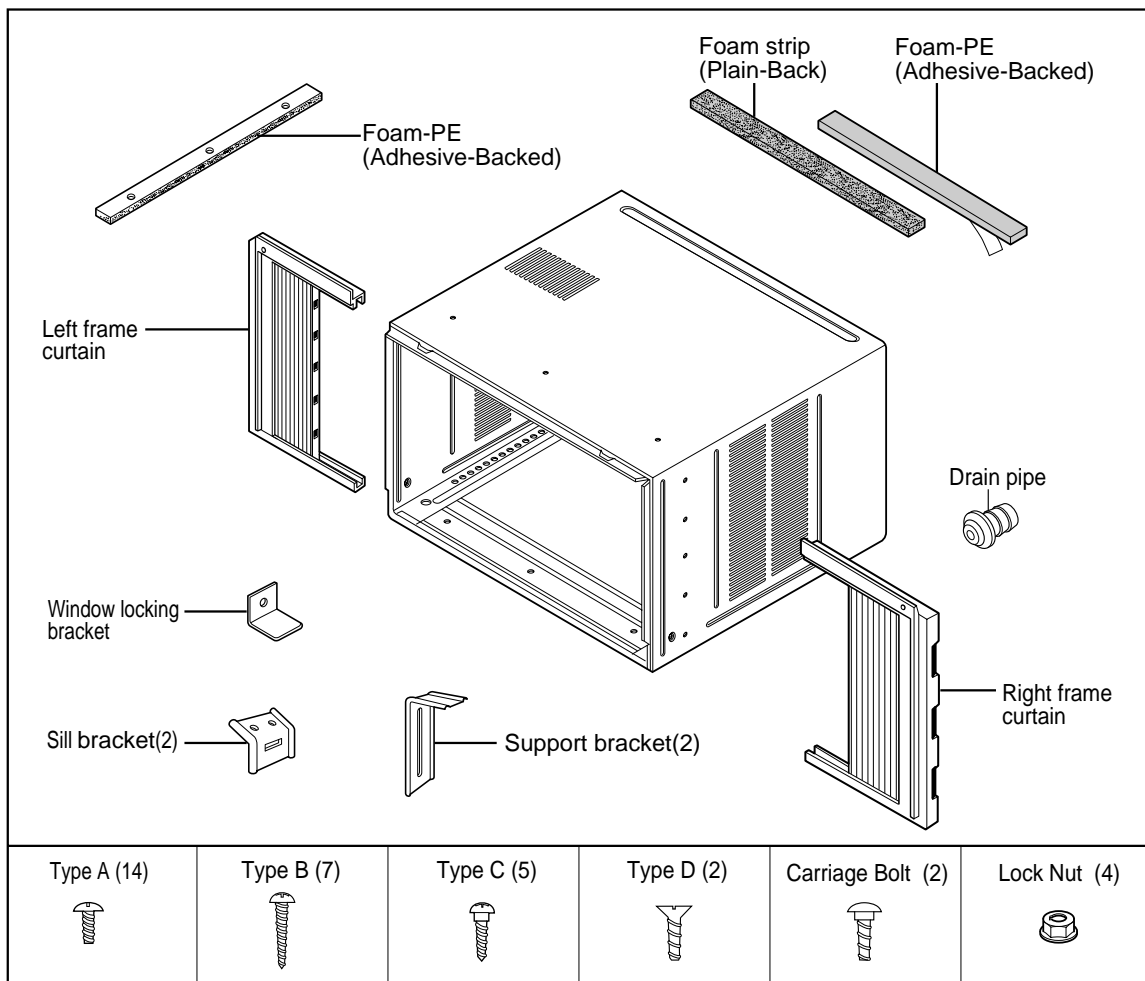

■ Top retainer bar is in product package.

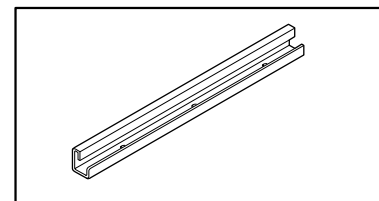

## Suggested tool Requirements

**SCREWDRIVER(+, -), RULER, KNIFE, HAMMER, PENCIL, LEVEL**

### Preparation of Chassis

1. Remove the screws which fasten the cabinet at both sides and at the back. Keep these two screws which fasten the cabinet at both sides for later use.
2. Slide the unit out from the cabinet by gripping the base pan handle and pulling forward while bracing the cabinet.
3. Cut the window sash seal to the proper length. Peel off the backing and attach the Foam-Seal to the underside of the window sash.
4. Remove the backing from Foam-PE with 3 holes and attach it to the bottom of the Top retainer bar.
5. Attach the Top retainer bar onto the top of the cabinet with 3 screws (Type A).
6. Insert the Frame guides into the bottom of the cabinet.
7. Insert the Frame Curtain into the Top retainer bar and Frame guides.
8. Fasten the curtains to the unit with 10 screws (Type A) at both sides.

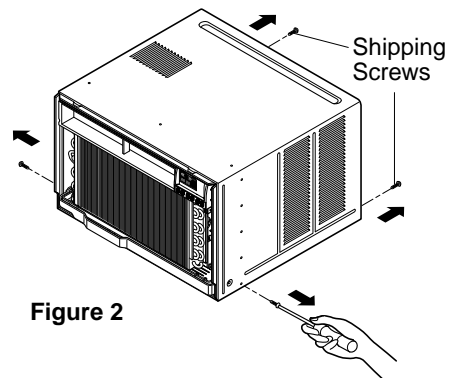

Figure 2

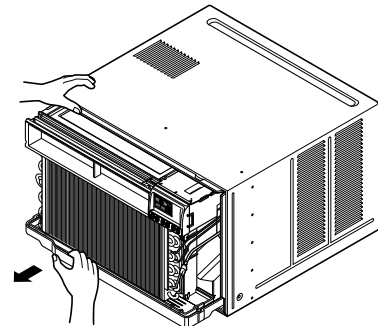

Figure 3

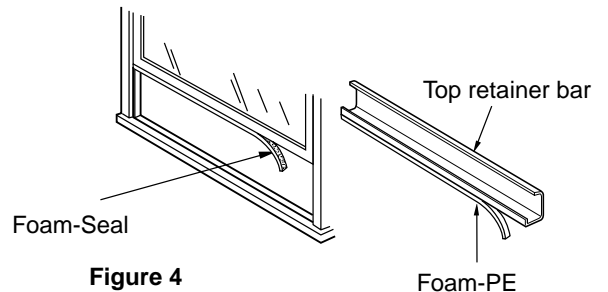

Figure 4

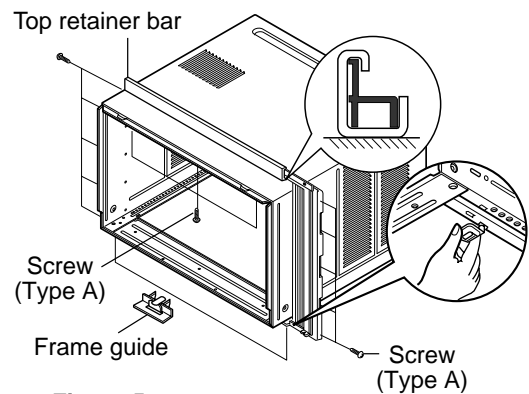
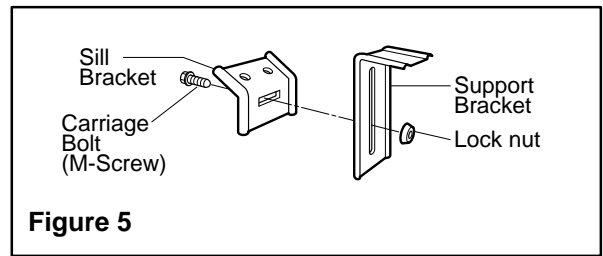

Figure 5

## Cabinet Installation

1. Open the window. Mark a line on the center of the window stool between the side window stop moldings. Loosely attach the sill bracket to the support bracket using the carriage bolt and the lock nut.



2. Attach the sill bracket to the window sill using the screws (Type B). Carefully place the cabinet on the window stool and align the center mark on the bottom front with the center line marked window stool.

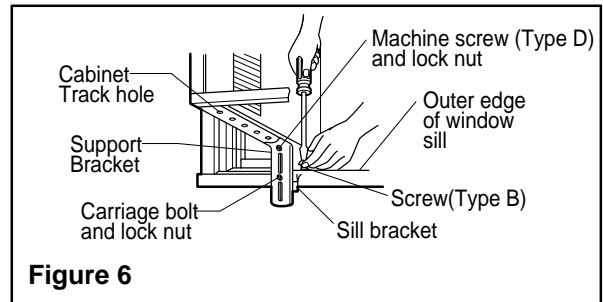

3. Using the M-screw and the lock nut, attach the support bracket to the cabinet track hole. Use the first track hole after the sill bracket on the outer edge of the window sill. Tighten the carriage bolt and the lock nut. Be sure the cabinet slants outward.



**CAUTION: Do not drill a hole in the bottom pan. The unit is designed to operate with approximately 1/2" of water in bottom pan.**

4. Pull the bottom window sash down behind the Top retainer bar until they meet.

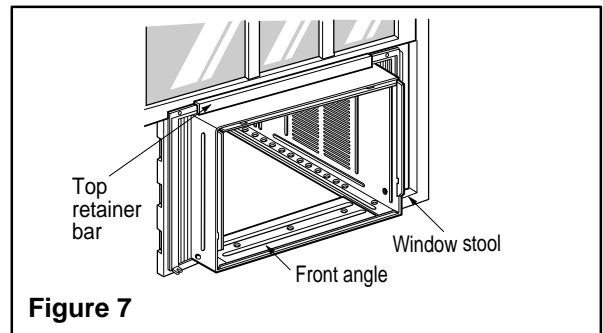

Figure 7

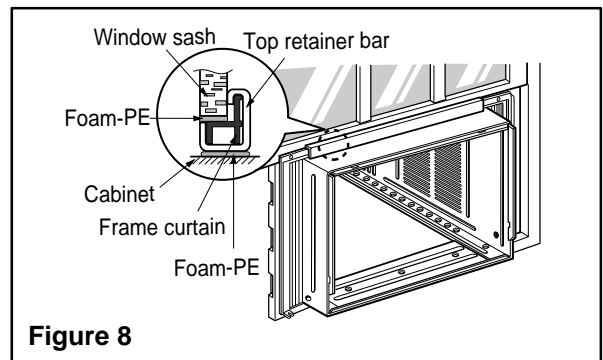

Figure 8

### NOTICE

1. Do not pull the window sash down so tightly that the movement of Frame curtain is restricted. Attach the cabinet to the window stool by driving the screws (Type B) through the cabinet into window stool.
2. The cabinet should be installed with a very slight tilt downward toward the outside.

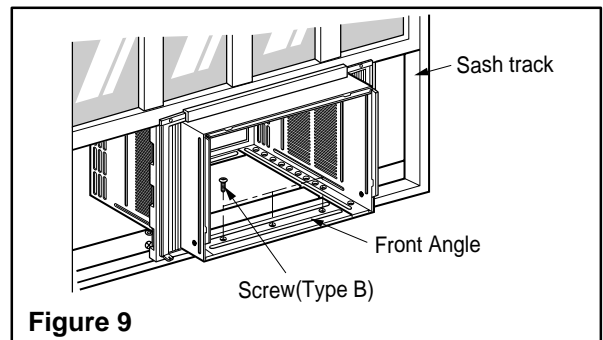
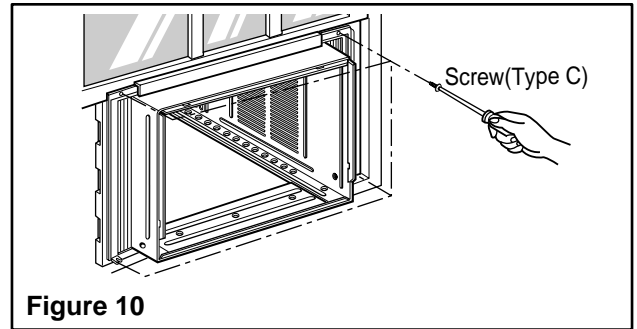

Figure 9

5. Pull each Frame curtain fully to each window sash track, and pull the bottom window sash down behind the Top retainer bar until it meets.
6. Attach each Frame curtain the window sash by using screws (Type C). (See Fig. 10)



7. Slide the unit into the cabinet. (See Fig. 11)

**CAUTION:** For security purpose, reinstall screws (Type A) at cabinet's sides.

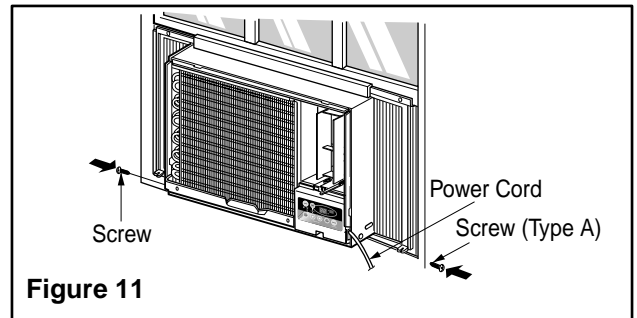

8. Cut the Foam-strip to the proper length and insert between the upper window sash and the lower window sash. (See Fig. 12)

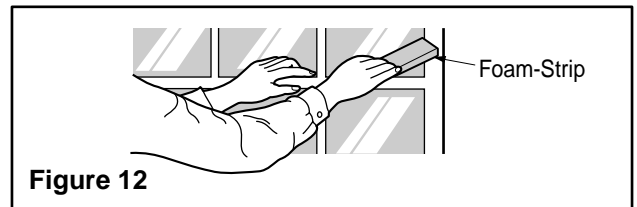

9. Attach the Window locking bracket with a screw (Type C). (See Fig. 13)

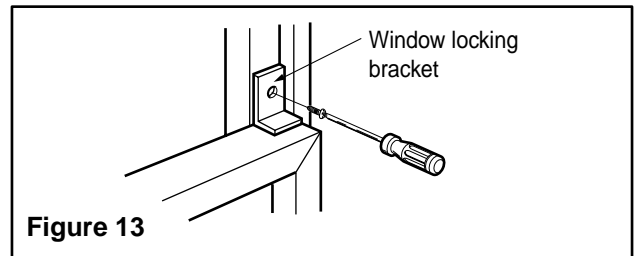

10. Attach the front grille to the cabinet by inserting the tabs on the grille into the tabs on the front of the cabinet. Push the grille in until it snaps into place. (See Fig.14)

11. Lift the inlet grille and secure it with a screw (Type A) through the front grille. (See Fig. 14)

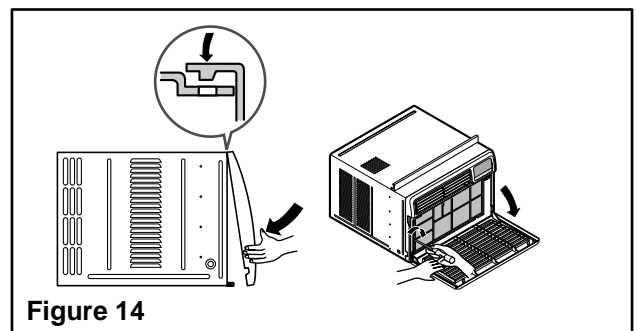

12. **Window installation of room air conditioner is now completed.**

# Operation

## Function of Controls

- Designed for COOLING ONLY.
- Powerful and quiet cooling.
- Slide-in and slide-out chassis for the simple installation and service.
- Low air-intake, top cooled-air discharge.
- Built-in adjustable Thermistor
- Washable one-touch filter
- Compact size
- Equipped with reliable and efficient rotary compressor.

### DISPLAY

LW1800PR, LW1500PR,  
LWP1830WAL, LW1804ER

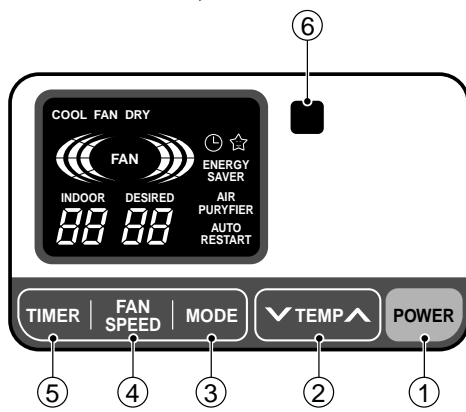

LW1500PRY3, LW1800PRZ3

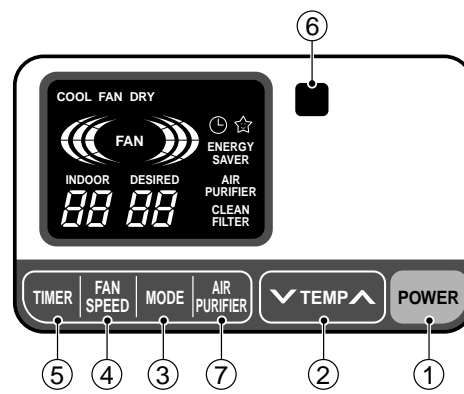

### REMOTE CONTROL

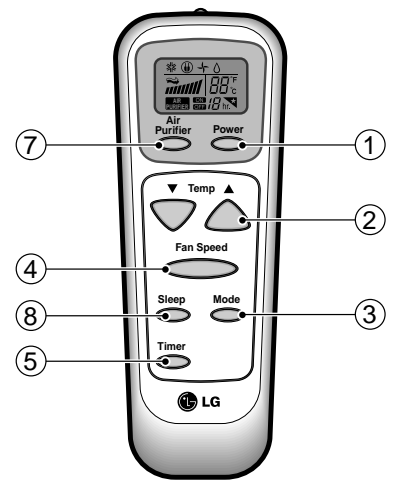

**Precaution:** The Remote Control unit will not function properly if strong light strikes the sensor window of the air conditioner or if there are obstacles between the Remote Control unit and the air conditioner.

#### 1 POWER BUTTON

To turn the air conditioner ON, push the button. To turn the air conditioner OFF, push the button again. This button takes priority over any other buttons.

#### 2 ROOM TEMPERATURE SETTING BUTTON

This button can automatically control the temperature of the room. The temperature can be set within a range of 60°F to 86°F by 1°F. (16°C to 30°C by 1°C)  
Select the lower number for lower temperature of the room.

#### 3 OPERATION MODE SELECTION BUTTON

Every time you push this button, it will shift among COOL, ENERGY SAVER, FAN and DRY as follows.

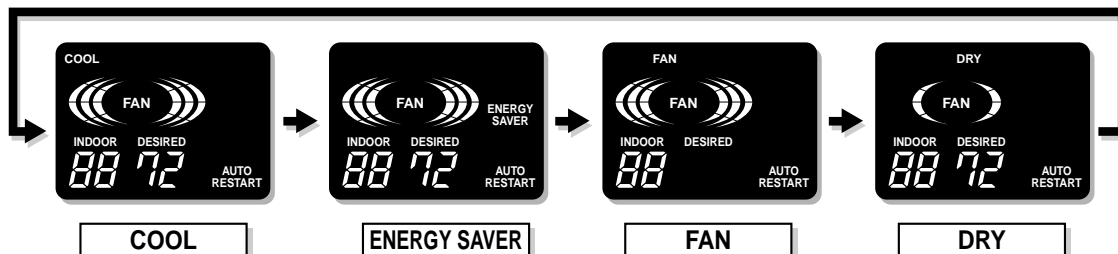

- Energy Saver: If Energy Save mode is selected, the fan stops when the compressor stops cooling. Approximately every 3 minutes the fan will turn on and check the room air to determine if cooling is needed.

**4 FAN SPEED SELECTOR**

Every time you push this button, it is set as follows.  
(Hi → Low → Med → Hi → Low →...)

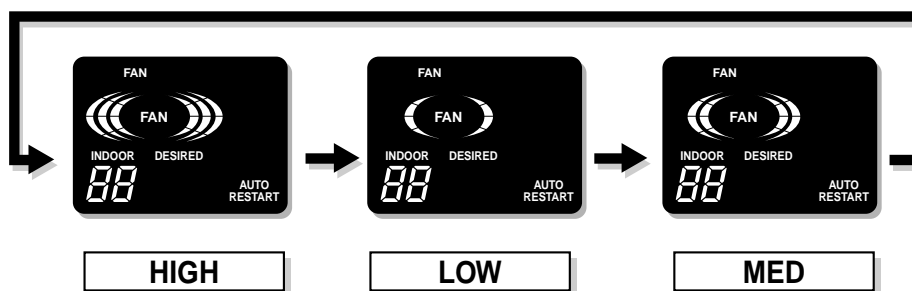
**5 ON/OFF TIMER BUTTON**

You can set the time when the unit will turn on or turn off automatically by pressing the timer button. If the unit is operating, this button controls the time it will be turned off. If the unit is off state, this button controls the time it will start. Every time you push this button, the remaining time will be set as follows.

- Stopping operation

(1Hour → 2Hours → 3Hours → 4Hours → 5Hours → 6Hours → 7Hours → 8Hours → 9Hours → 10Hours → 11Hours → 12Hours → 0Hour → 1Hour → 2Hours →... )

- Starting operation

(1Hour → 2Hours → 3Hours → 4Hours → 5Hours → 6Hours → 7Hours → 8Hours → 9Hours → 10Hours → 11Hours → 12Hours → off → 1Hour → 2Hours → ... )

**6 REMOCON SIGNAL RECEIVER****7 AIR PURIFIER**

- Press the Air Purifier button.  
Operation will start when the button is pressed and stop when the button is pressed again.
- Set the fan speed with the remote control. You can select the fan speed in three steps high, low or medium.  
Each time the button is pressed, the fan speed mode is shifted.
- If you press the only Air Purifier button, only air purifying operates.  
Then, fan speed is low. You can select the fan speed in three steps high, low or medium.  
Each time the button is pressed, the fan speed mode is shifted.

**8 SLEEP MODE**

- Press the sleep mode button to set the time you want the unit to turn off automatically.
- Every time you push this button, the remaining time will be set as follows.  
(1Hour → 2Hours → 3Hours → 4Hours → 5Hours → 6Hours → 7Hours → 0Hour → 1Hour → 2Hours → ... )
- The temperature setting will be raised by 2°F in 30 minutes and by 4°F in 1 hour to prevent overcooling during sleep.

**DISPLAY**

**REMOTE CONTROL**

**LW1800ER**

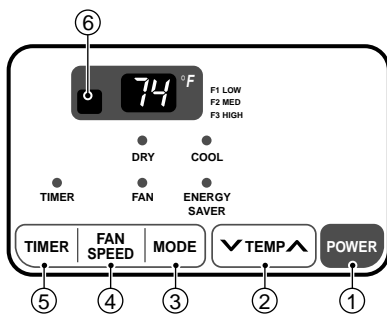

**LWC182PLMM0, LWC212PLMM0**

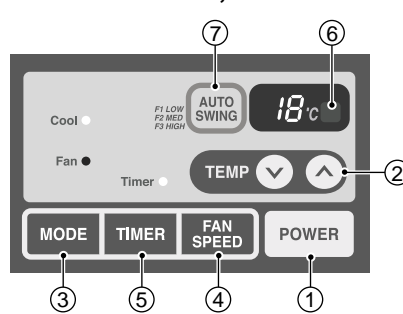

**LW1800ERZ3, HBLG1803R**

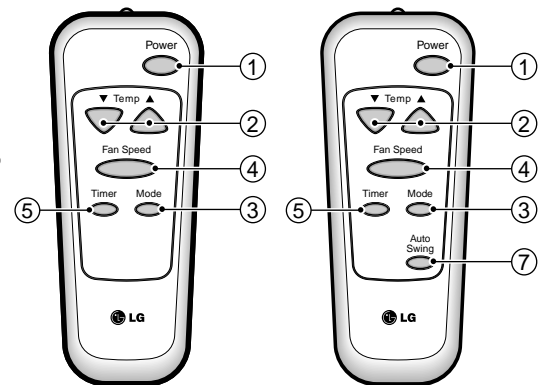
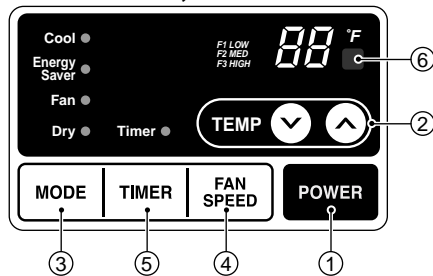

**Precaution:** The Remote Control unit will not function properly if strong light strikes the sensor window of the air conditioner or if there are obstacles between the Remote Control unit and the air conditioner.

**1 POWER BUTTON**

To turn the air conditioner ON, push the button. To turn the air conditioner OFF, push the button again. This button takes priority over any other buttons.

**2 ROOM TEMPERATURE SETTING BUTTON**

This button can automatically control the temperature of the room. The temperature can be set within a range of 60°F to 86°F by 1°F. (16°C to 30°C by 1°C)  
Select the lower number for lower temperature of the room.

**3 OPERATION MODE SELECTION BUTTON**

Every time you push this button, it will shift among COOL, ENERGY SAVER, FAN and DRY.

- Energy Saver: If Energy Save mode is selected, the fan stops when the compressor stops cooling. Approximately every 3 minutes the fan will turn on and check the room air to determine if cooling is needed.

**4 FAN SPEED SELECTOR**

Every time you push this button, it is set as follows.  
(Hi [F3] → Low [F1] → Med [F2] → Hi [F3] → Low [F1] →...)

**5 ON/OFF TIMER BUTTON**

You can set the time when the unit will turn on or turn off automatically by pressing the timer button. If the unit is operating, this button controls the time it will be turned off. If the unit is off state, this button controls the time it will start. Every time you push this button, the remaining time will be set as follows.

- Stopping operation  
(1Hour → 2Hours → 3Hours → 4Hours → 5Hours → 6Hours → 7Hours → 8Hours → 9Hours → 10Hours → 11Hours → 12Hours → 0Hour → 1Hour → 2Hours →...)

- Starting operation  
(1Hour → 2Hours → 3Hours → 4Hours → 5Hours → 6Hours → 7Hours → 8Hours → 9Hours → 10Hours → 11Hours → 12Hours → off → 1Hour → 2Hours → ...)

**6 REMOCON SIGNAL RECEIVER**

**7 AUTO SWING**

This button can automatically control the air flow direction.

■ LWP1820PDL/PEL

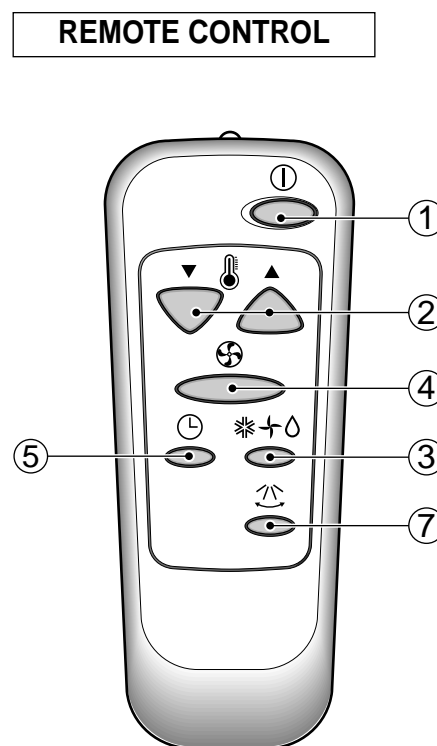
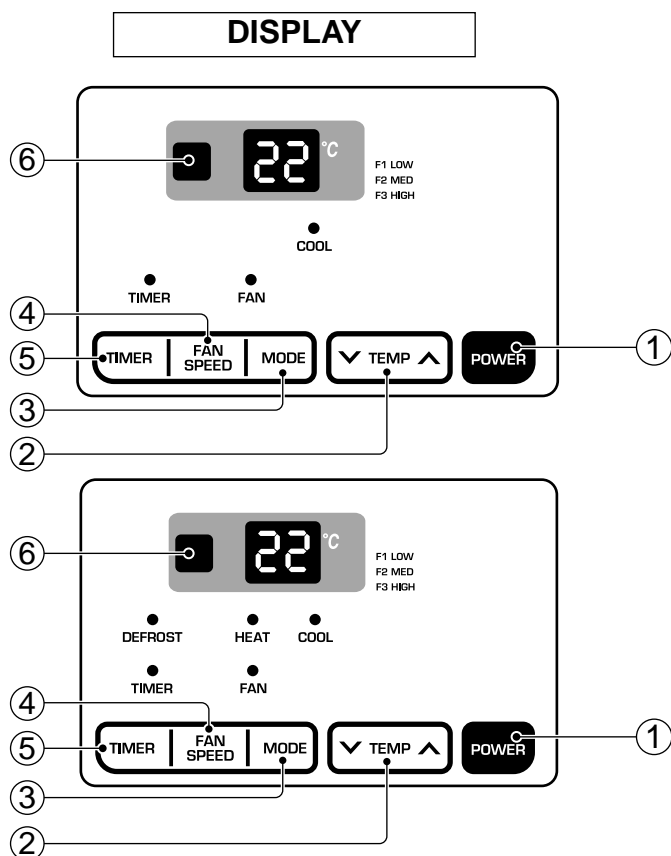

**1 POWER BUTTON**

Operation starts, when this button is pressed and stops when you press the button again.

**2 ROOM TEMPERATURE SETTING BUTTON**

Control the room temperature within a range of 16°C to 30°C. The room temperature will be adjusted by 1°C 30min., and by 2°C 1 hour later.

**3 OPERATION MODE SELECTION BUTTON**

Select Cooling, Heating, or Fan mode with this button.

**4 FAN SPEED SELECTOR**

Select the fan speed. Cooling Model: 3 steps {High[F3] → Low[F1] → Med[F2]→ High[F3]... }  
 Heating Model: 2 steps {High [F2] → Low[F1] → High[F2]... }

**5 ON/OFF TIMER BUTTON**

Set the time of starting and stopping operation. The timer is set by 1 hour.

**6 SIGNAL RECEIVER**

**7 AUTO SWING**

The vertical louver swings horizontally by the automatic system and stops when you press the button again.

# Disassembly

— Before the following disassembly, **CONTROL BOX** set to OFF and disconnect the power cord.

## Mechanical Parts

### 1. Front Grille

1. Open the Inlet grille downward and remove the air filter.
2. Remove the screw that fastens the front grille.(See Figure 15)
3. Pull the front grille from the right side.
4. Remove the front grille.(There are 4 hooks.)
5. Re-install the components by referring to the removal procedure, above.

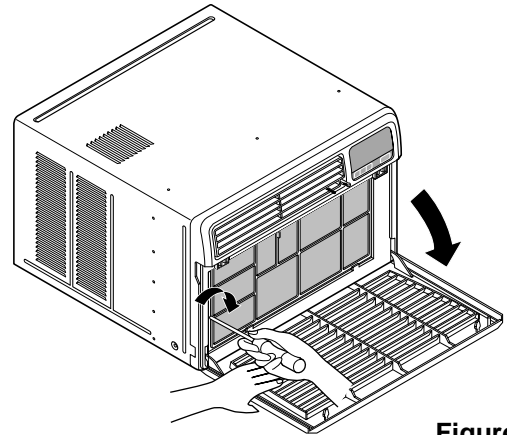

Figure 15

### 2. Cabinet

1. After disassembling the FRONT GRILLE, remove the 2 screws that fasten the cabinet at both sides.
2. Remove the 2 screws that fasten the cabinet at back.
3. Pull the base pan forward. (See Figure 16)
4. Remove the cabinet.
5. Re-install the components by referring to the removal procedure, above.

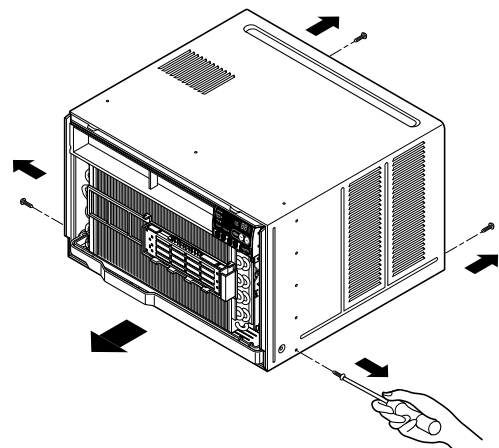

Figure 16

### 3. Control Box

1. Remove the front grille. (Refer to section 1)
2. Remove the cabinet. (Refer to section 2)
3. Remove the 2 screws which fasten the power cord.
4. Disconnect the grounding screw from the evaporator channel.
5. Remove the 1 screw that fastens the control box cover.
6. Remove the housing that connects PCB and motor wire in the control box.
7. Disconnect the housing that connects Plazma Air Purifier.(Optional)
8. Remove the screw at left cover of filter case and open the cover to remove inner screw. (Optional)
9. Remove the nut that fastens the terminal cover.
10. Remove the terminal cover.
11. Remove all the leads from the overload protector.
12. Discharge the capacitor by placing a 20,000 ohm resistor across the capacitor terminals.
13. Raise the control box upward completely. (See Figure 17)
14. Re-install the components by referring to the removal procedure, above.  
(Refer to the wiring diagram found on page 25 in this manual and on the control box.)

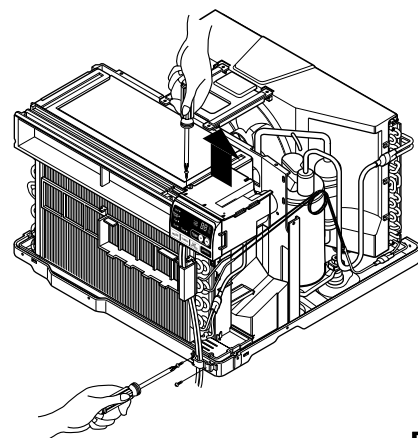

Figure 17

## Air Handling Parts

### 4. Air Guide and Turbo Fan

1. Remove the front grille. (Refer to section 1)
2. Remove the cabinet. (Refer to section 2)
3. Remove the control box. (Refer to section 3)
4. Remove the 4 screws that fasten the brace.
5. Remove the brace.
6. Remove the 2 screws that fasten the air guide upper.
7. Remove the air guide upper. (See Figure 18)
8. Remove the 2 screws that fasten the evaporator.
9. Move the evaporator forward and pulling it upward slightly. (See Figure 19)
10. Pull out the hook of orifice by pushing the tabs and remove it. (See Figure 20)
11. Remove the clamp with a hand plier that secures the turbo fan.
12. Remove the turbo fan.
13. Remove the 2 screws that fasten the air guide from the base pan.
14. Move the air guide backward, and pull out from the base pan. (Move the air guide lower carefully.)
15. Re-install the components by referring to the removal procedure, above.

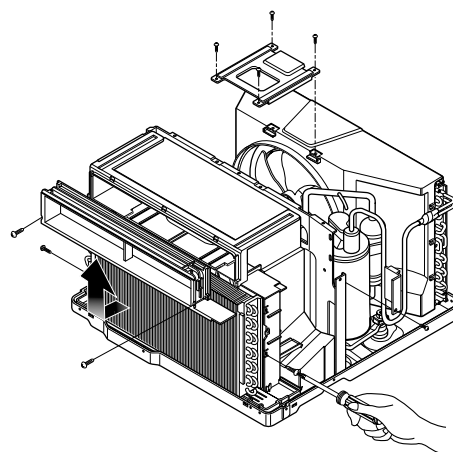

Figure 18

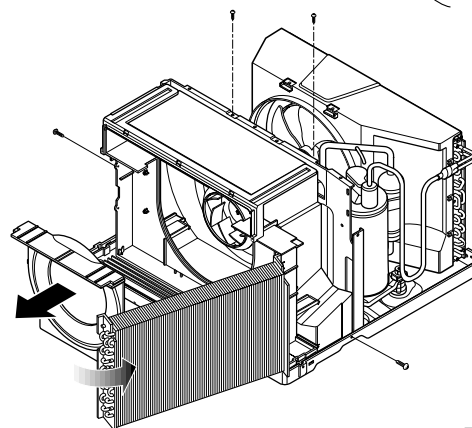

Figure 19

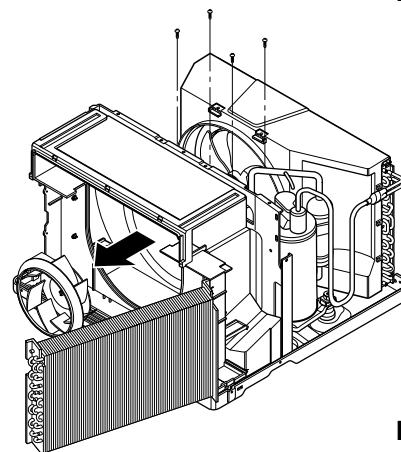

Figure 20

### 5. FAN

1. Remove the cabinet. (Refer to section 2)
2. Remove the brace (Refer to section 4)
3. Remove the 5 screws that fasten the condenser.
4. Move the condenser to the left carefully.
5. Remove the clamp that secures the fan.
6. Remove the fan. (See Figure 21)
7. Re-install by referring to the removal procedure.

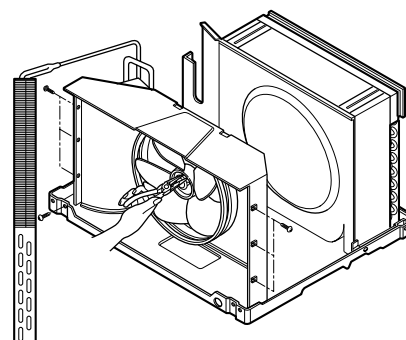

Figure 21

## 6. Shroud

1. Remove the fan. (Refer to section 5)
2. Remove the shroud. (See Figure 22)
3. Re-install the components by referring to the removal procedure, above.

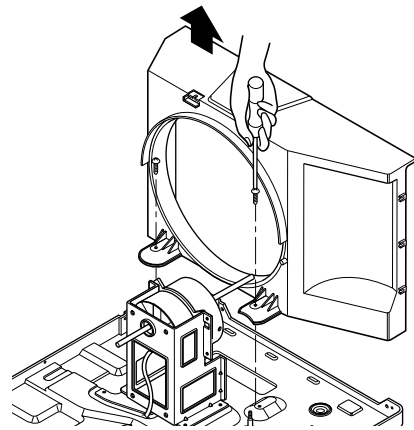

Figure 22

## Electrical Parts

### 7. Overload Protector

1. Remove the cabinet. (Refer to section 2)
2. Remove the nut that fastens the terminal cover.
3. Remove the terminal cover. (See Figure 23)
4. Remove all the leads from the overload protector.
5. Remove the overload protector.
6. Re-install the components by referring to the removal procedure, above.

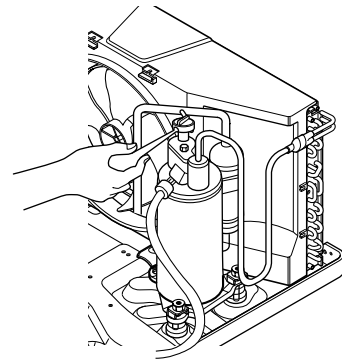

Figure 23

### 8. Compressor

1. Remove the cabinet. (Refer to section 2)
2. Discharge the refrigerant system using a Freon™ Recovery System.  
If there is no valve to attach the recovery system, install one (such as a WATCO A-1) before venting the Freon™. Leave the valve in place after servicing the system.
3. Remove the overload protector. (Refer to section 7)
4. After purging the unit completely, unbraid the suction and discharge tubes at the compressor connections.
5. Remove the 3 nuts and the 3 washers which fasten the compressor.
6. Remove the compressor. (See Figure 24)
7. Re-install the components by referring to the removal procedure, above.

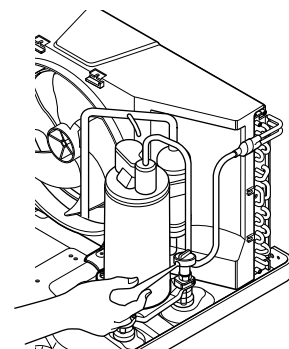

Figure 24

## 9. Capacitor

1. Remove the control box. (Refer to section 3)
2. Open the top cover from the control box. (See Figure 25)
3. Pull out the capacitor from the control box.
4. Disconnect all the leads of capacitor terminals.
5. Re-install the components by referring to the removal procedure, above.

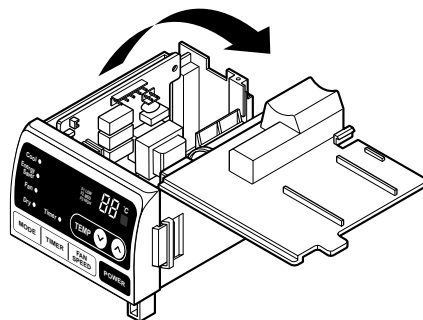

Figure 5

## 10. Power Cord

1. Remove the control box. (Refer to section 3)
2. Open the top cover from the control box. (Refer to section 9)
3. Disconnect the front panel from the control box. (See Figure 26)
4. Disconnect two leads from the capacitor and relay.
5. Pull out the power cord.
6. Re-install the component by referring to the above removal procedure, above. (Use only one ground-marked hole for ground connection.)
7. If the supply cord of this appliance is damaged, it must be replaced by the special cord. (The special cord means the cord which has the same specification marked on the supply cord attached at the unit.)

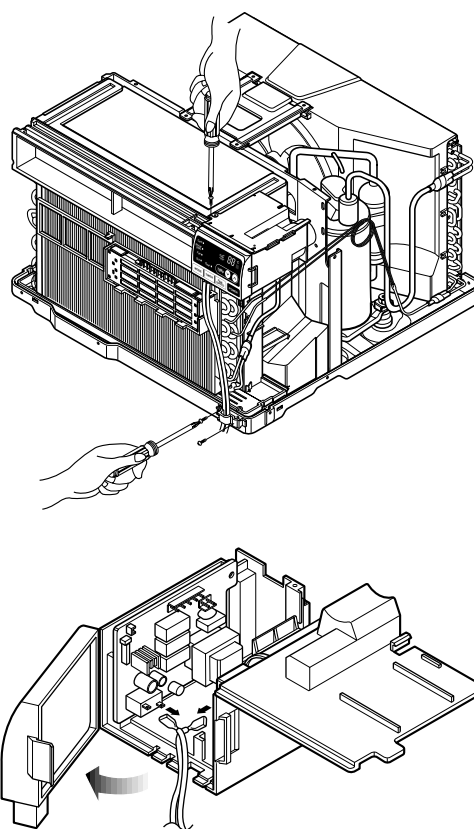

Figure 26

### 11. Motor

1. Remove the cabinet. (Refer to section 2)
2. Remove the turbo fan. (Refer to section 4)
3. Remove the fan. (Refer to section 5)
4. Remove the 4 screws that fasten the motor from the air guide. (See Figure 27)
5. Remove the motor.
6. Re-install the components by referring to the removal procedure, above.(See Figure 27)

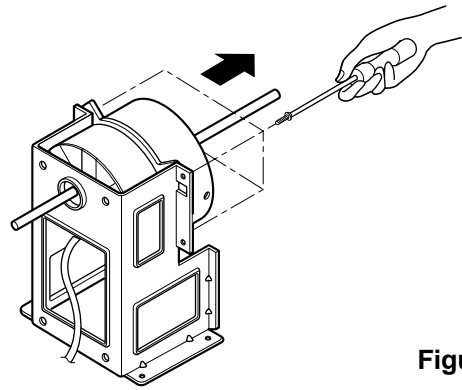

Figure 27

## Refrigerating Cycle

### 12. Condenser

**CAUTION:** Discharge the refrigerant system using a Freon™ Recovery System. If there is no valve to attach the recovery system, install one (such as a WATCO A-1) before venting the Freon™. Leave the valve in place after servicing the system.

1. Remove the cabinet. (Refer to section 2)
2. Remove the 4 screws that fasten the brace.(Refer to section 4)
3. Remove the 5 screws that fasten the condenser and shroud.
4. After discharging the refrigerant completely, unbrazed the interconnecting tube at the condenser connections.
5. Remove the condenser.
6. Re-install the components by referring to notes. (See Figure 28)

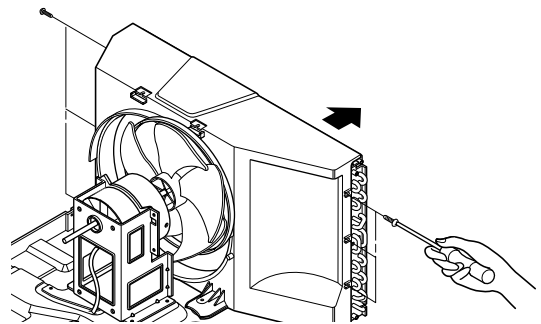

Figure 28

### 13. Evaporator

1. Remove the control box.(Refer to section 3)
2. Remove the air guide upper. (Refer to section 4)
3. Remove the 2 screws that fasten the evaporator.
4. Move the evaporator sideways carefully. (Refer to section 4)
5. After discharging the refrigerant completely, unbrazed the interconnecting tube at the evaporator connections.
6. Remove the evaporator.
7. Re-install the components by referring to notes. (See Figure 29)

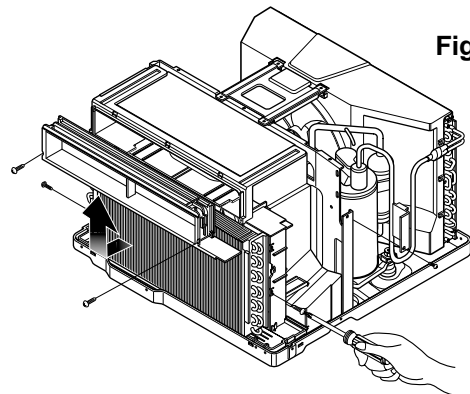

Figure 29

## 14. Capillary Tube

1. Remove the cabinet. (Refer to section s2)
2. After discharging the refrigerant completely, unbraid the interconnecting tube at the capillary tube. (See caution above)

### NOTICE

— Replacement of the refrigeration cycle.

1. When replacing the refrigeration cycle, be sure to Discharge the refrigerant system using a Freon™ recovery System.  
If there is no valve to attach the recovery system, install one (such as a WATCO A-1) before venting the Freon™. Leave the valve in place after servicing the system.
2. After discharging the unit completely, remove the desired component, and unbraid the pinch-off tubes.
3. Braid service valves into the pinch-off tube ports, leaving the valves open.
4. Braid the pinch-off tubes with Service valves.
5. Evacuate as follows.
  - 1) Connect the vacuum pump, as illustrated figure 30A.
  - 2) Start the vacuum pump, slowly open manifold valves A and B with two full turns counterclockwise and leave the valves open.  
The vacuum pump is now pulling through valves A and B up to valve C by means of the manifold and entire system.

**CAUTION:** If high vacuum equipment is used, just crack valves A and B for a few minutes, then open slowly with the two full turns counterclockwise. This will keep oil from foaming and being drawn into the vacuum pump.

- 3) Operate the vacuum pump vacuum for 20 to 30 minutes, until 600 microns of vacuum is obtained. Close valves A and B, and observe vacuum gauge for a few minutes. A rise in pressure would indicate a possible leak or moisture remaining in the system. With valves A and B closed, stop the vacuum pump.
- 4) Remove the hose from the vacuum pump and place it on the charging cylinder. See figure 30B.  
Open valve C.  
Discharge the line at the manifold connection.
- 5) The system is now ready for final charging.

3. Remove the capillary tube.
4. Re-install the components by referring to notes.

6. Recharge as follows :

- 1) Refrigeration cycle systems are charged from the High-side. If the total charge cannot be put in the High-side, the balance will be put in the suction line through the access valve which you installed as the system was opened.
- 2) Connect the charging cylinder as shown in figure 30B.  
With valve C open, discharge the hose at the manifold connection.
- 3) Open valve A and allow the proper charge to enter the system. Valve B is still closed.
- 4) If more charge is required, the high-side will not take it. Close valve A.
- 5) With the unit running, open valve B and add the balance of the charge.
  - a. Do not add the liquid refrigerant to the Low-side.
  - b. Watch the Low-side gauge; allow pressure to rise to 30 lbs.
  - c. Turn off valve B and allow pressure to drop.
  - d. Repeat steps b. and c. until the balance of the charge is in the system.
- 6) When satisfied the unit is operating correctly, use the pinch-off tool with the unit still running and clamp on to the pinch-off tube. Using a tube cutter, cut the pinch-off tube about 2 inches from the pinch-off tool. Use sil-fos brazing and braid pinch-off tube closed. Turn off the unit, allow it to set for a while, and then test the leakage of the pinch-off connection.

**Equipment needed:** Vacuum pump, Charging cylinder, Manifold gauge, Brazing equipment. Pin-off tool capable of making a vapor-proof seal, Leak detector, Tubing cutter, Hand Tools to remove components, Service valve.

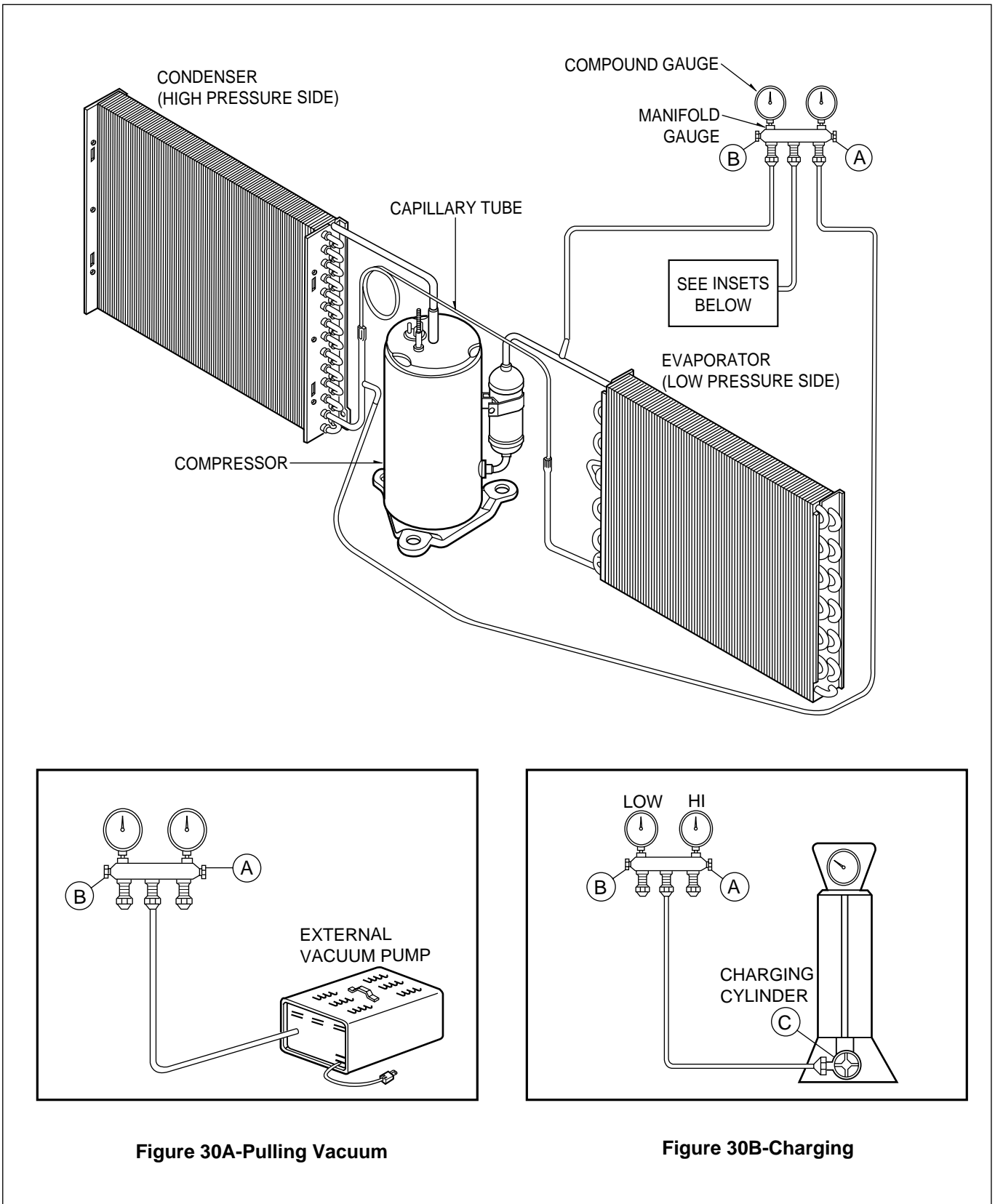

# Schematic Diagram

## Electronic Control Device

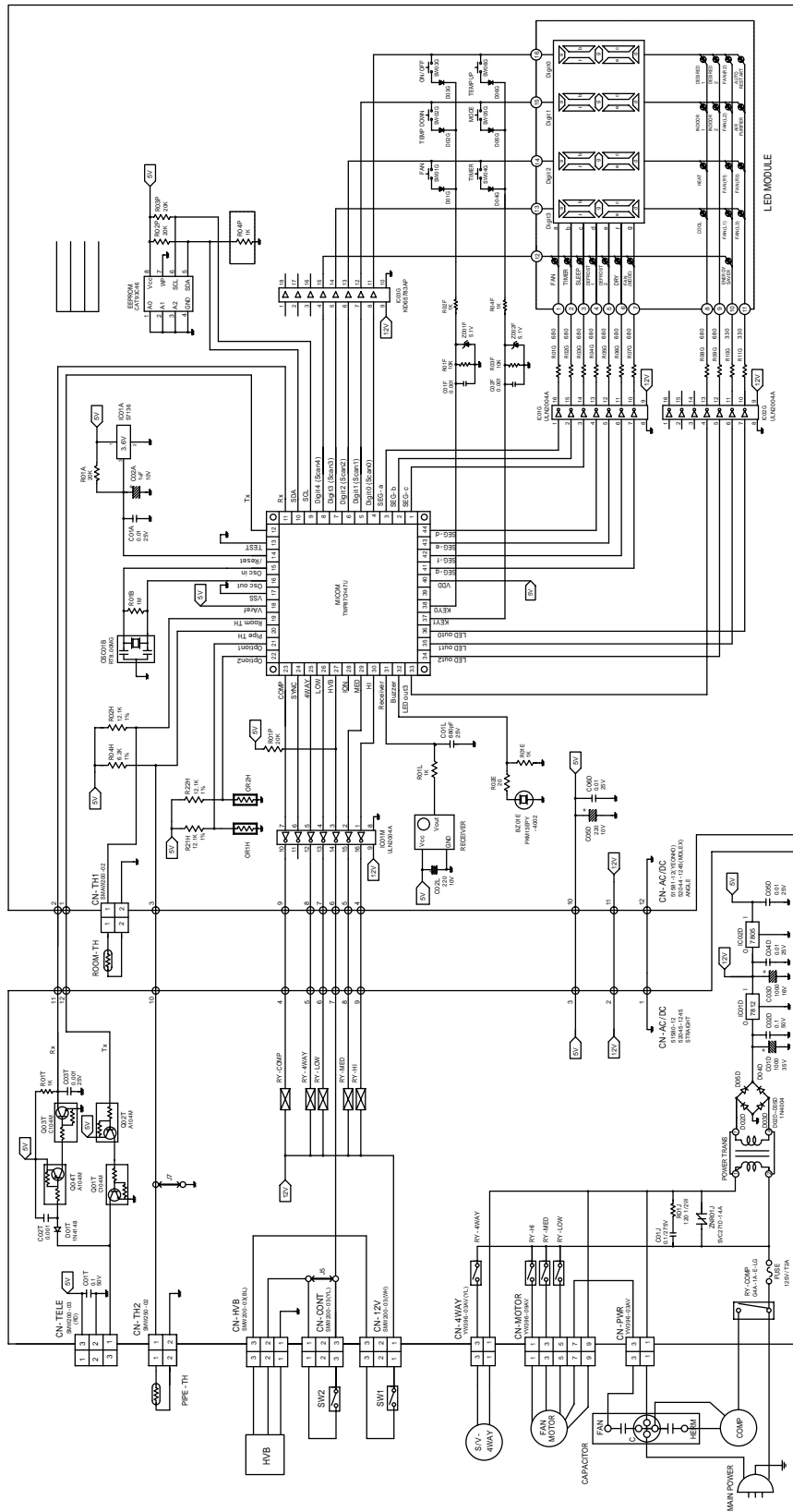



■ MODEL : LWP1820PDL/LWP1820PEL

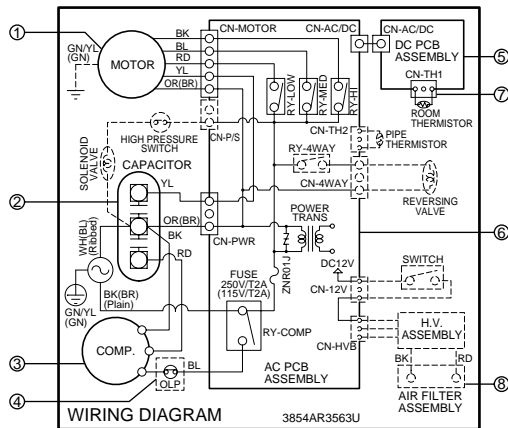

■ MODEL : LW1800ERZ3/LW1800PR, HBLG1803R  
LW1800ER/LWP1830WAL

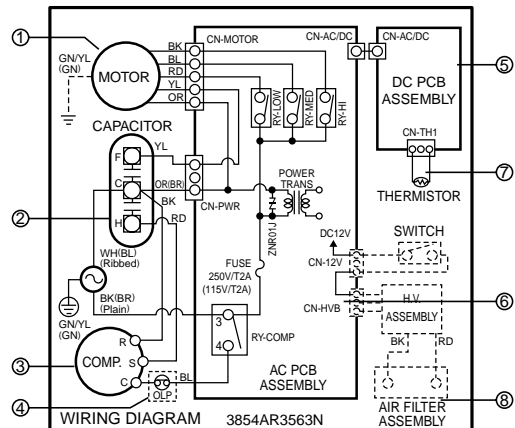

■ MODEL : LWC182PLMM0/LWC212PLMM0

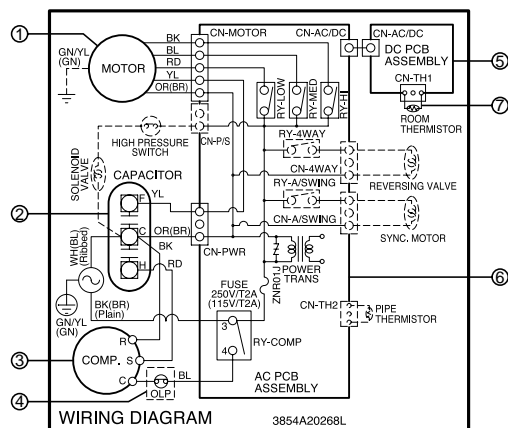

■ MODEL : LW1500PRY3/LW1500PR  
LW1800PRZ3/LW1804ER  
LWC182PLMD1

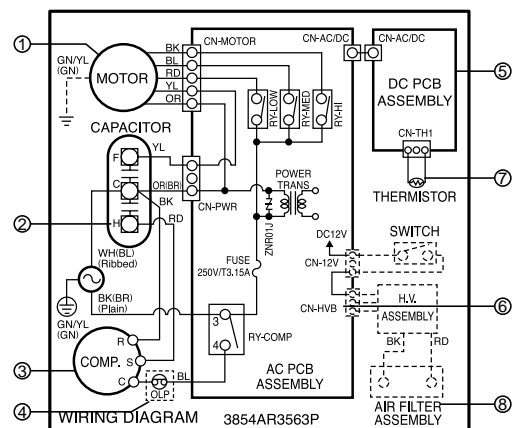

S: Service Parts  
N: Non Service Parts

LOCATION NO.	DESCRIPTION	Q'TY PER SET	REMARKS
1	MOTOR ASSY	1	S
2	CAPACITOR	1	S
3	COMPRESSOR	1	S
4	OVERLOAD PROTECTOR	1	S
5	DC PCB ASSEMBLY	1	S
6	AC PCB ASSEMBLY	1	S
7	THERMISTOR	1	S
8	PLASMA FILTER ASSY	1	S



■ MODEL: LW1800ER/LWP1820PDL/LWP1820PEL

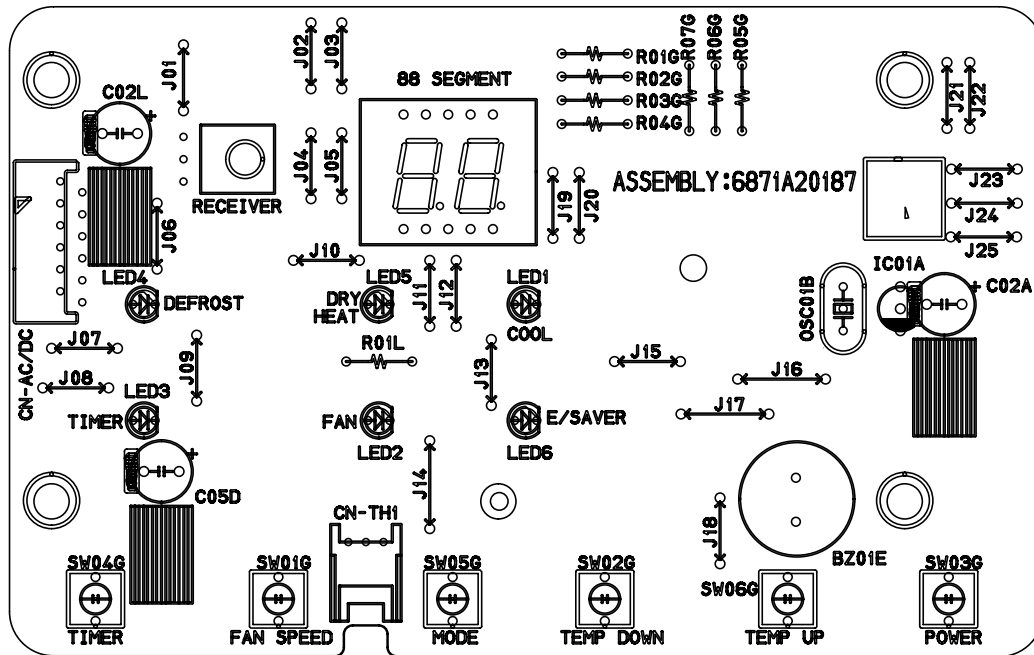

■ MODEL: LW1804ER/LW1500PRY3/LW1800PRZ3/LWC183PLMD1

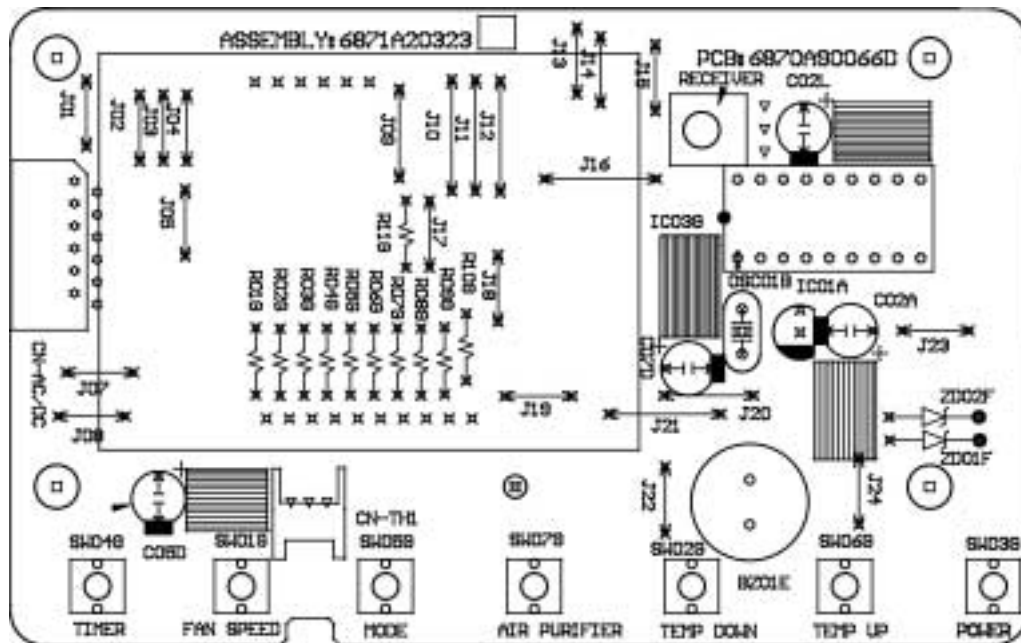

# Troubleshooting Guide

## Piping System

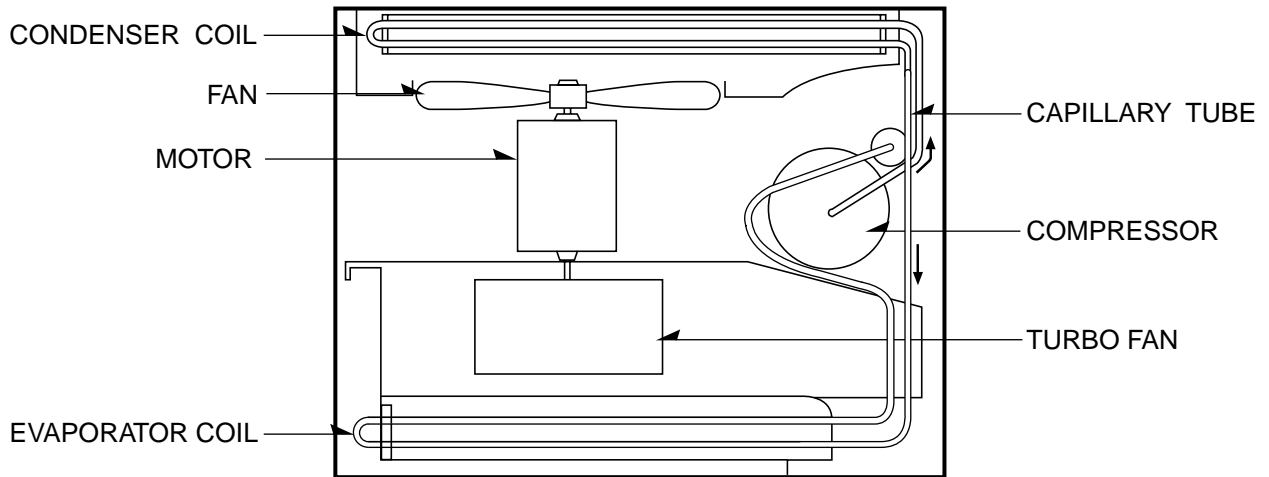
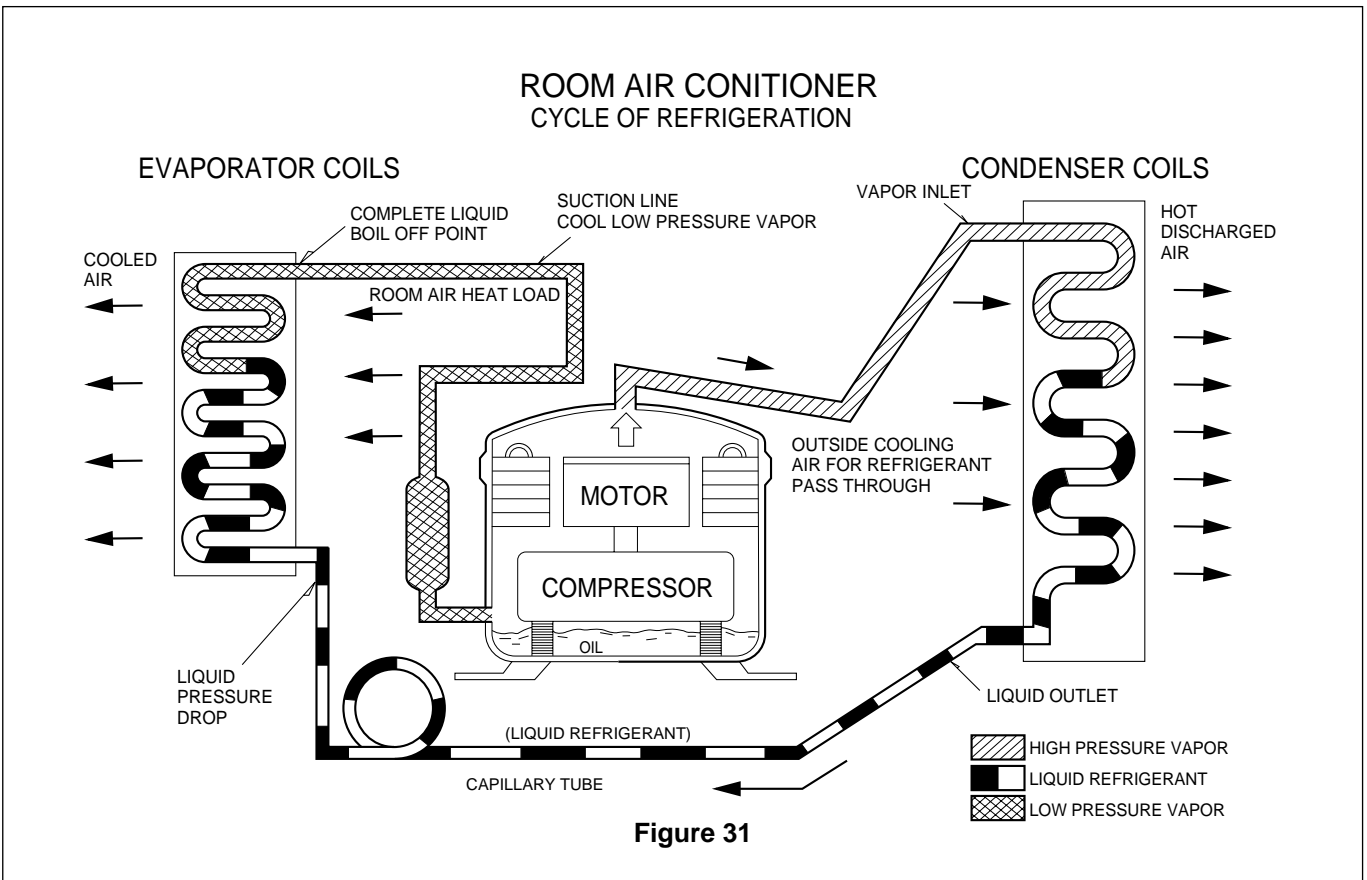

Figure 31 is a brief description of the important components and their function in what is called the refrigeration system. This will help you to understand the refrigeration cycle and the flow of the refrigerant in the cooling cycle.



# Troubleshooting Guide

In general, possible trouble is classified in two kinds.

The one is called Starting Failure which is caused from an electrical defect, and the other is ineffective Air Conditioning caused by a defect in the refrigeration circuit and improper application.

## Unit runs but poor cooling.

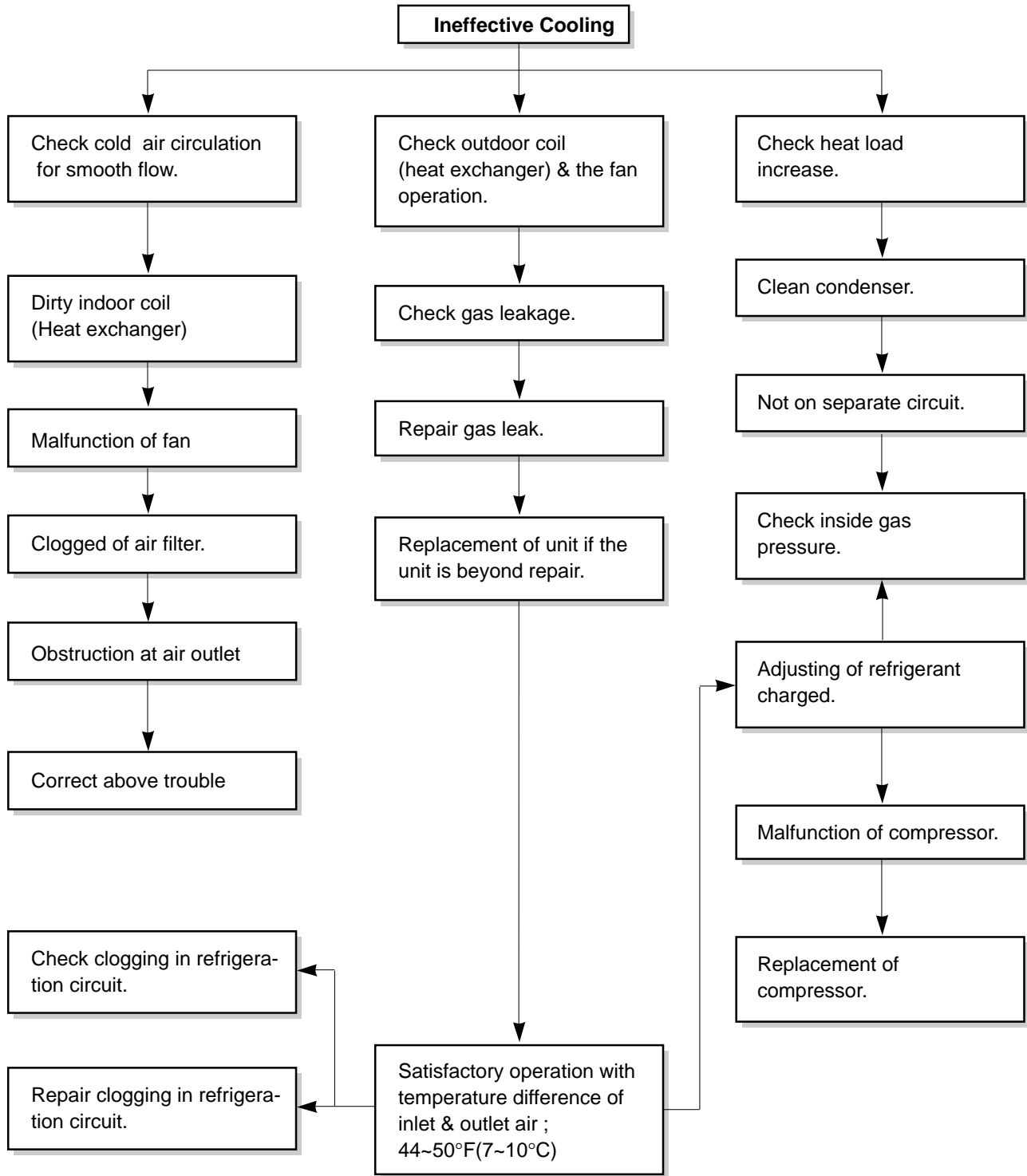

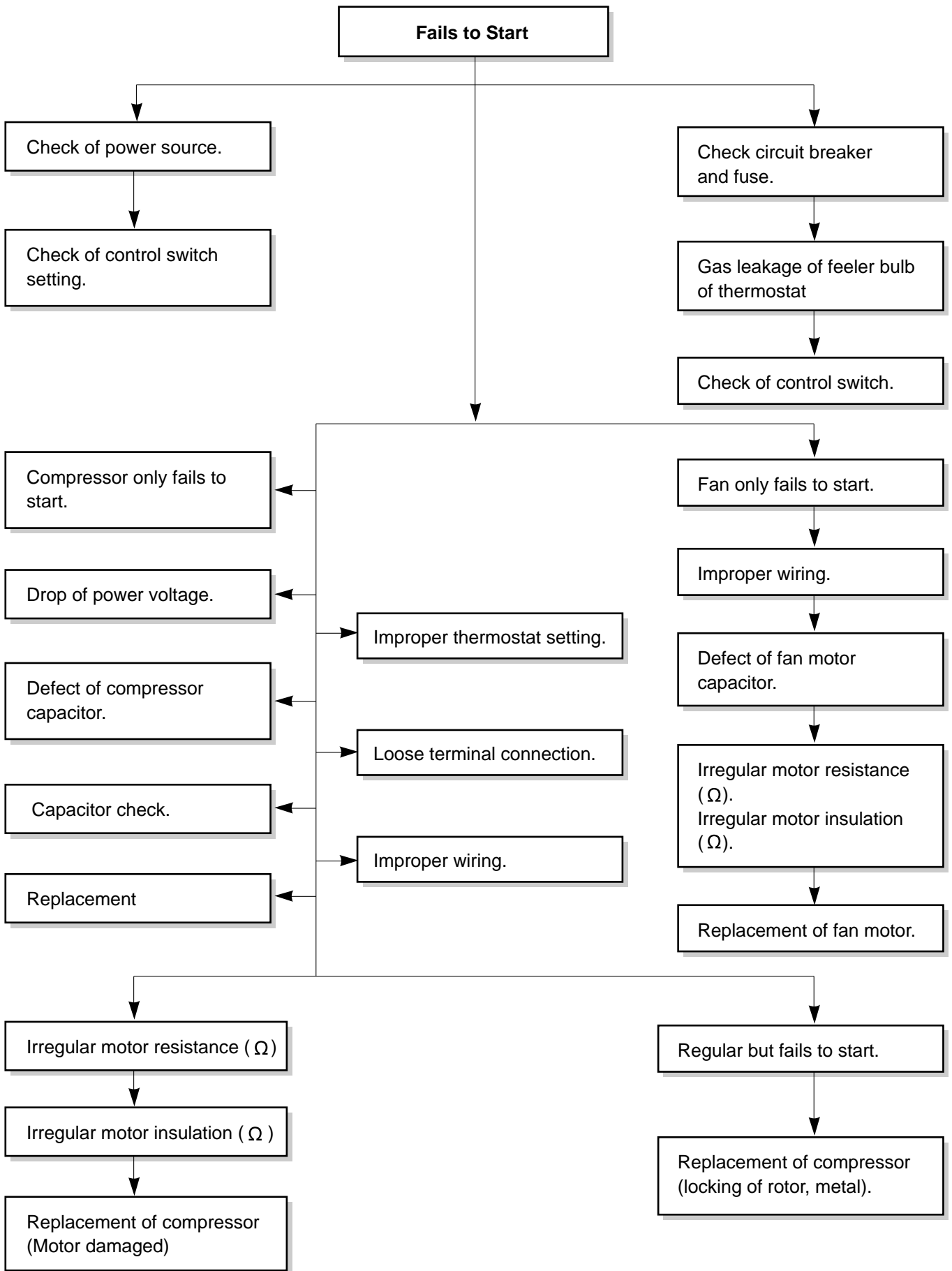

# Electrical Parts Troubleshooting Guide

**Possible Trouble 1** The unit does not operate.

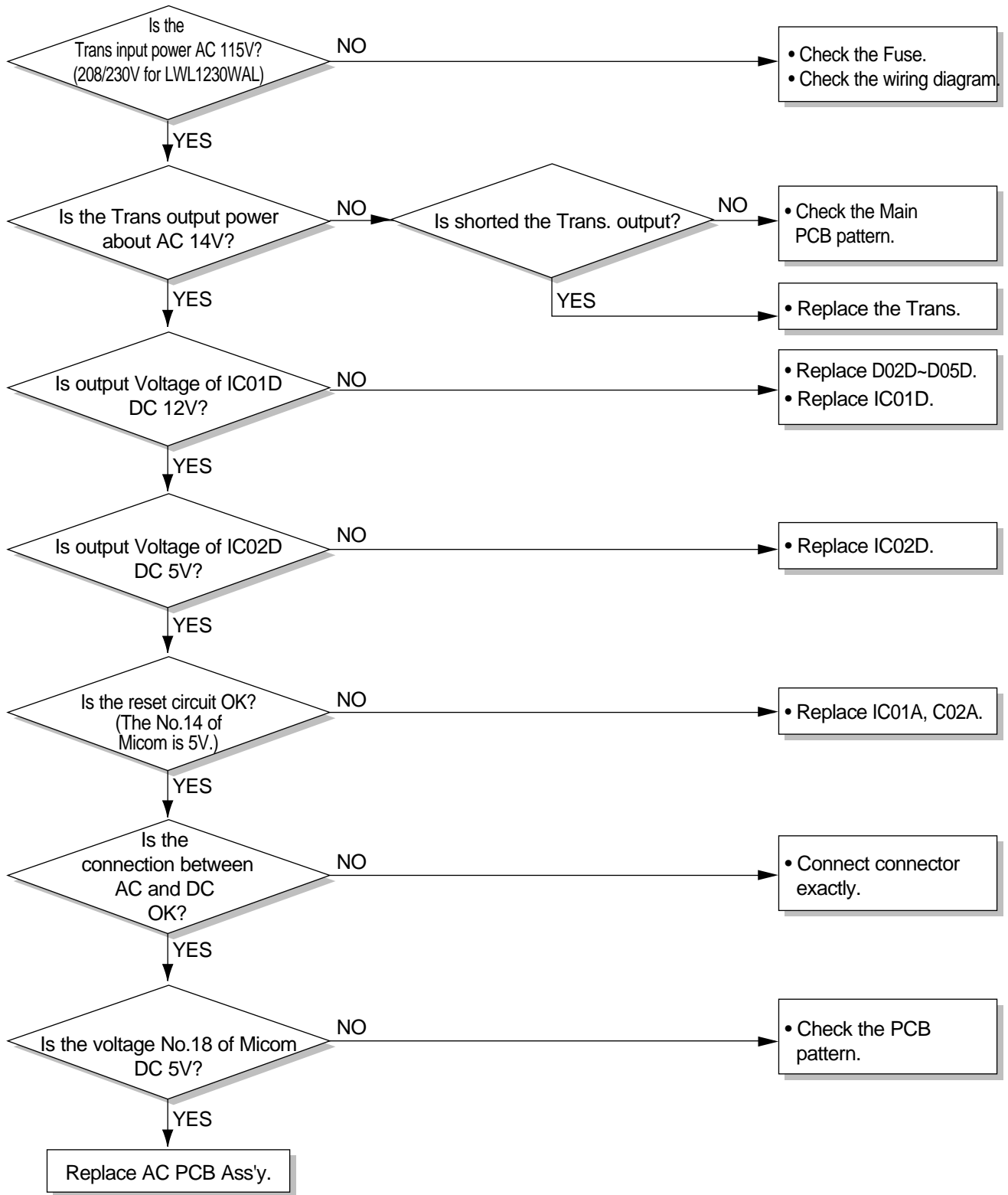

**Possible Trouble 2** The compressor does not operate.

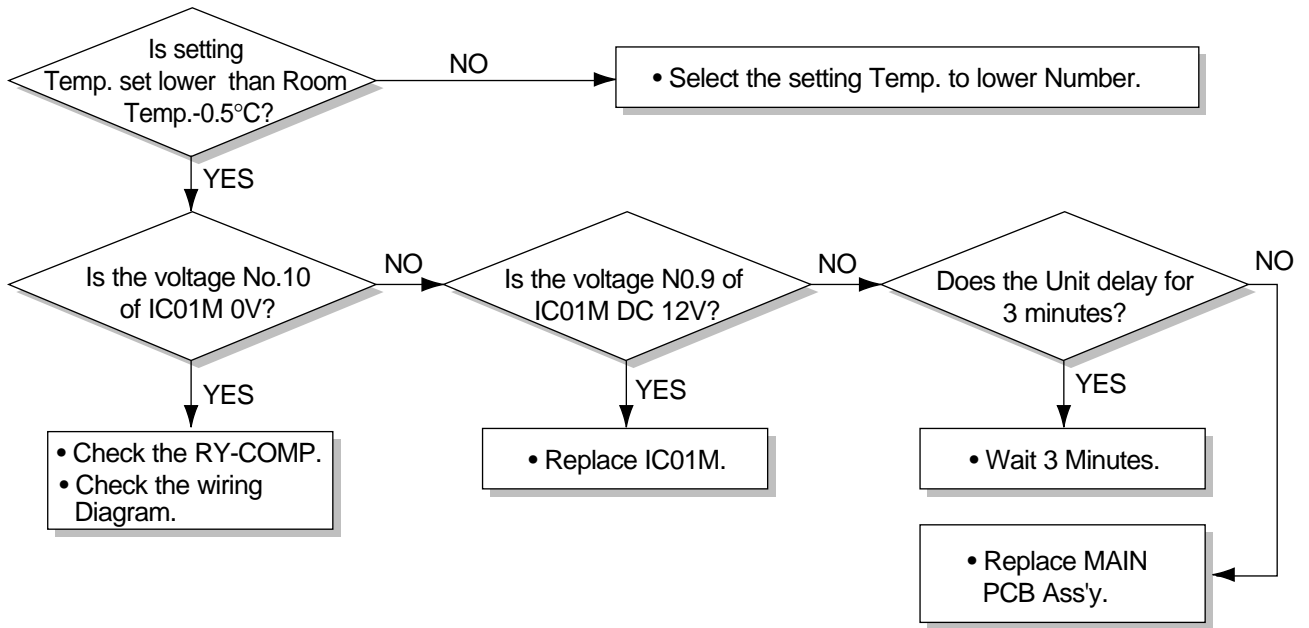

**Possible Trouble 3** The compressor always operate.



**Possible Trouble 4**

FAN does not operate.

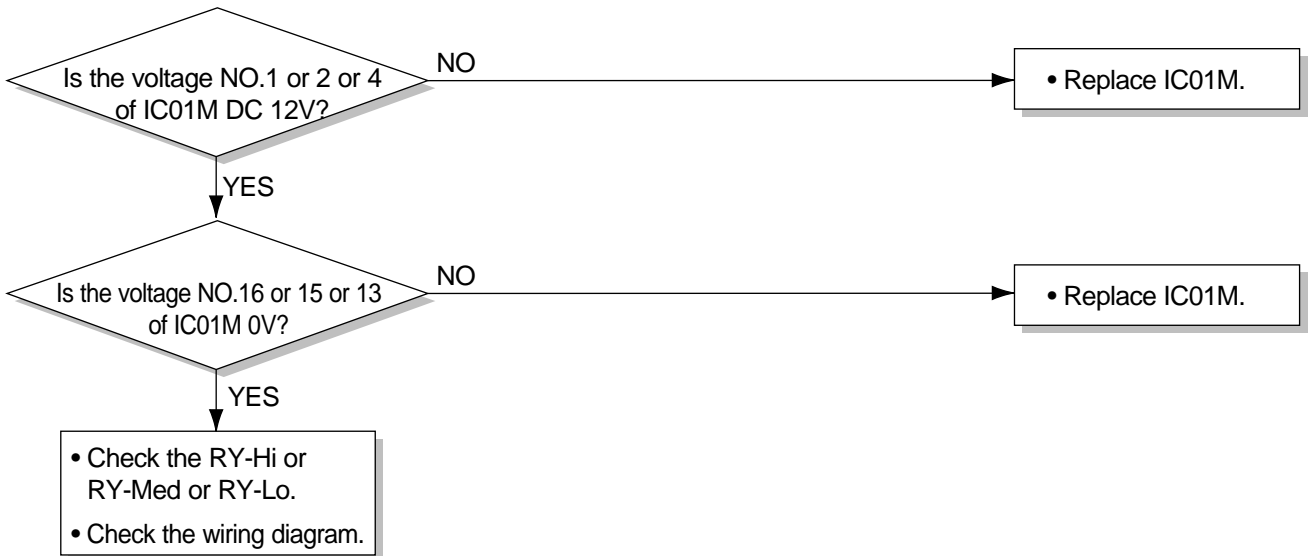

**Possible Trouble 5**

The function of Energy Saver does not operate.

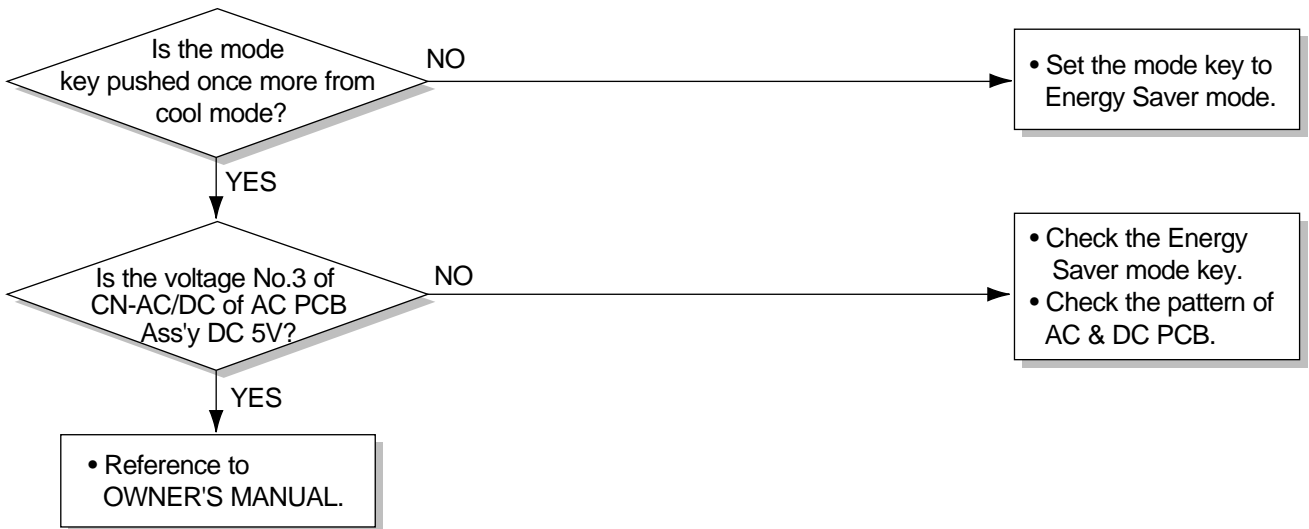

**Possible Trouble 6** Remote controller does not operate.

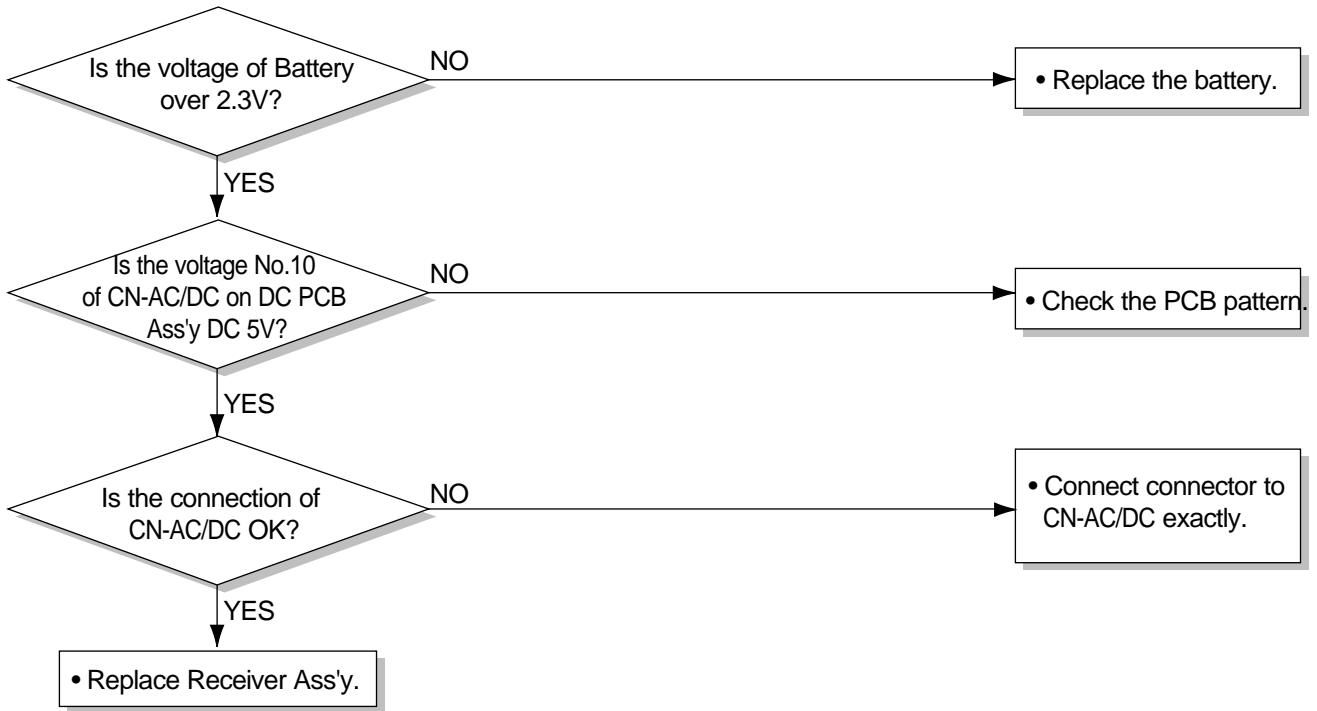

**Possible Trouble 7** It displays abnormally on DC PCB Ass'y.

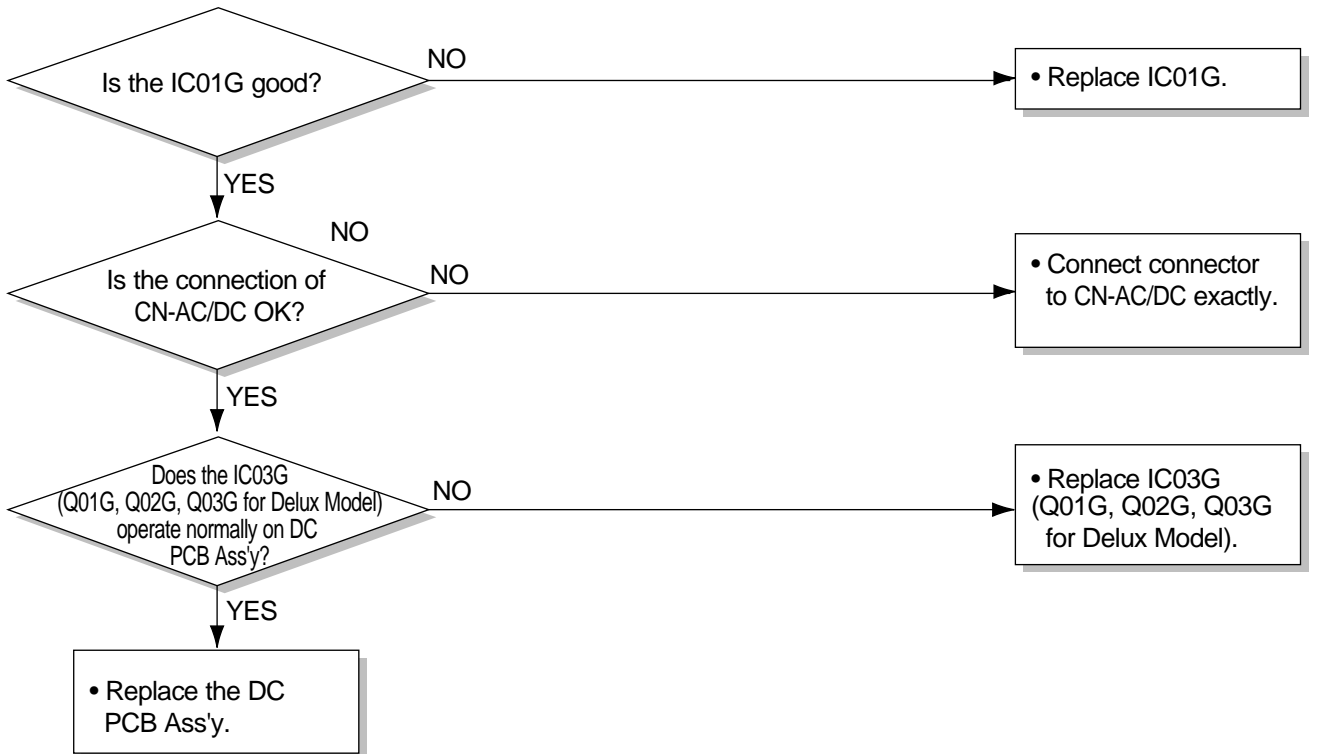

**Electric Parts**

**Possible Trouble 1**

The unit does not operate.

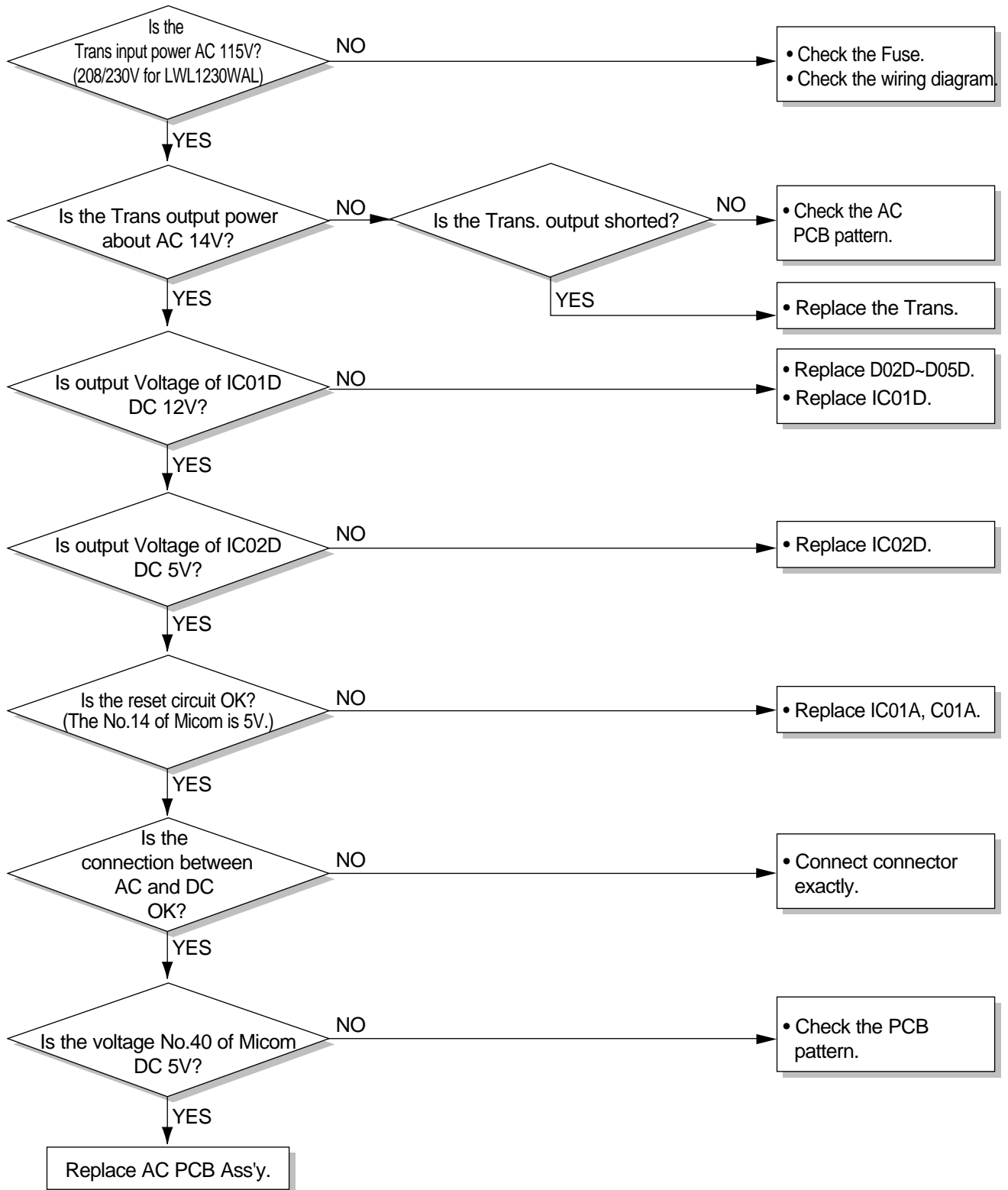

**Possible Trouble 2** The compressor does not operate.

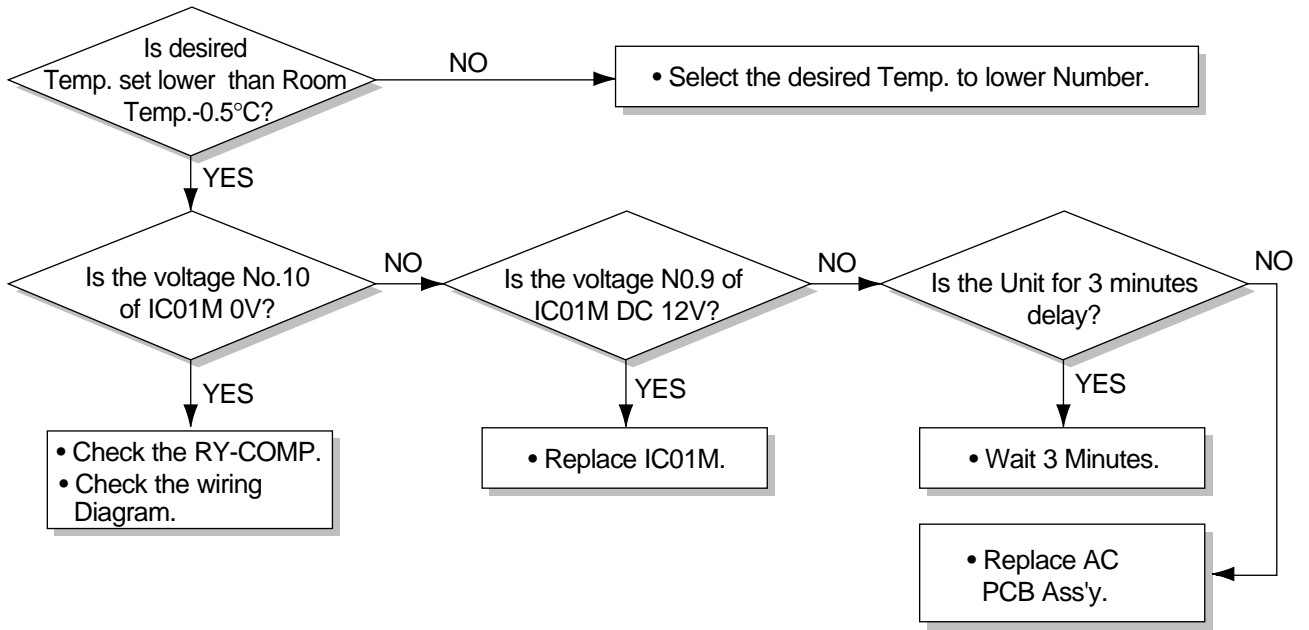

**Possible Trouble 3** The compressor always operate.

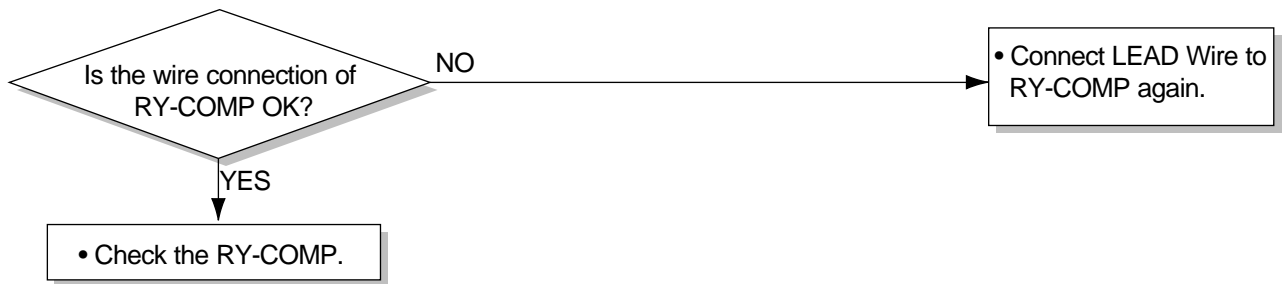

**Possible Trouble 4** FAN does not operate.

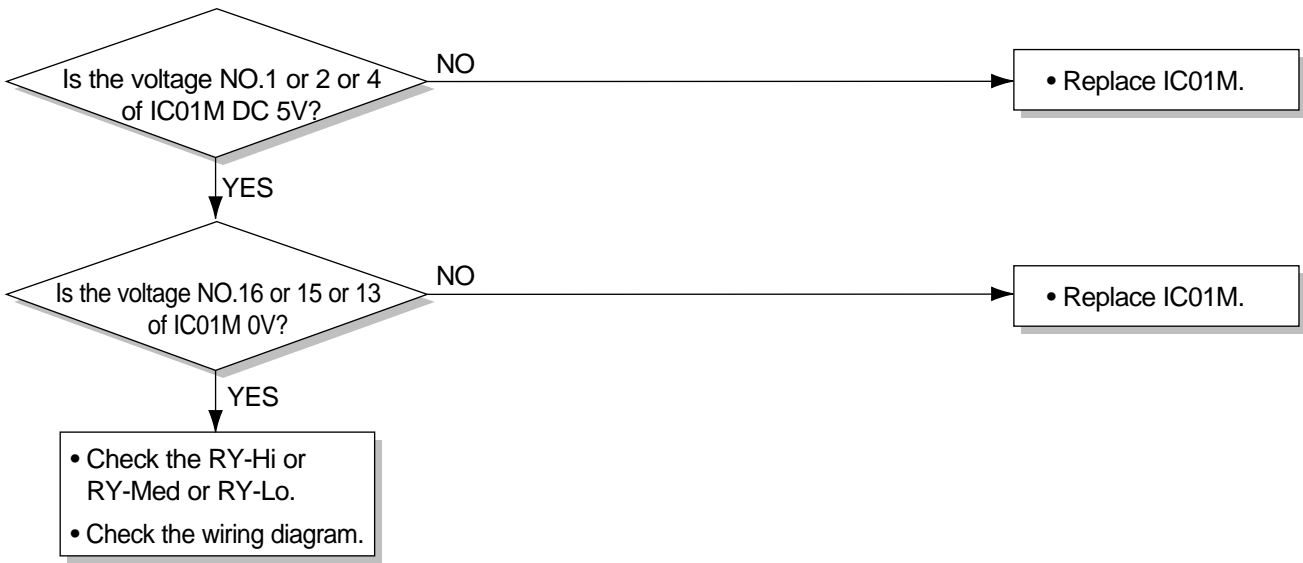

**Possible Trouble 5** Remote controller does not operate.

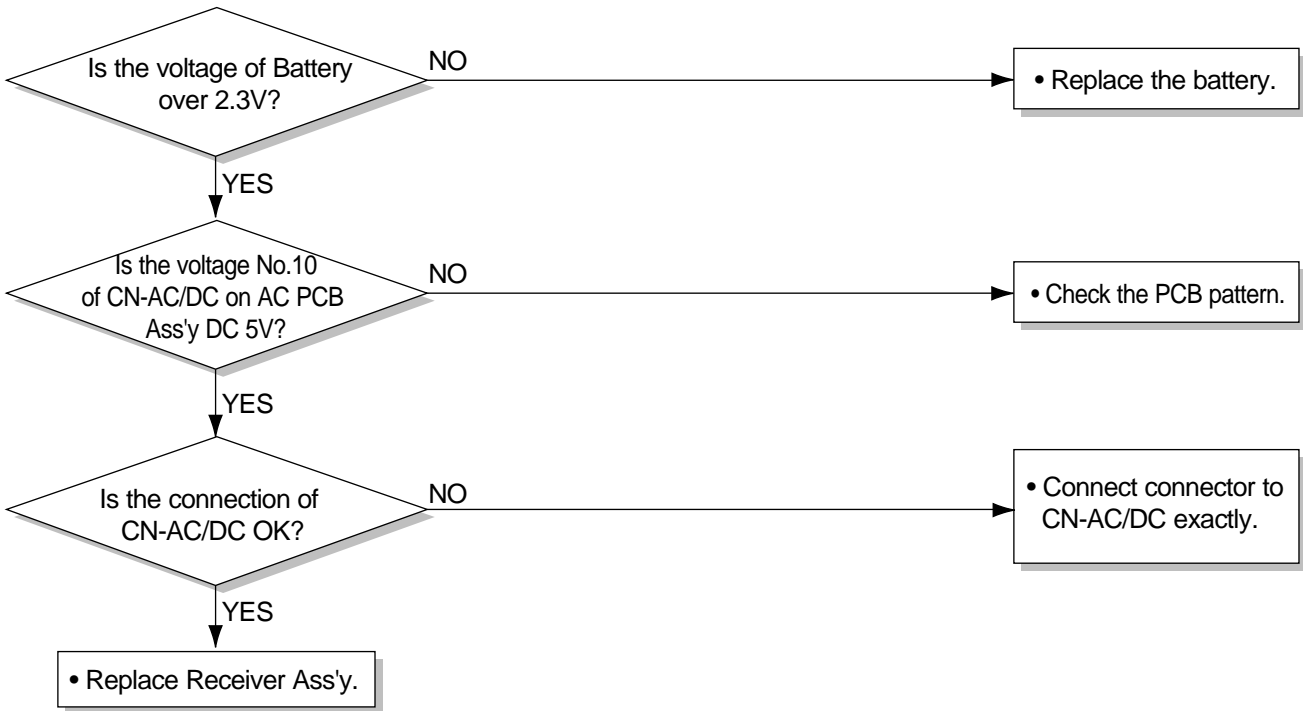

**Possible Trouble 6**

It displays abnormally on DC PCB Ass'y.

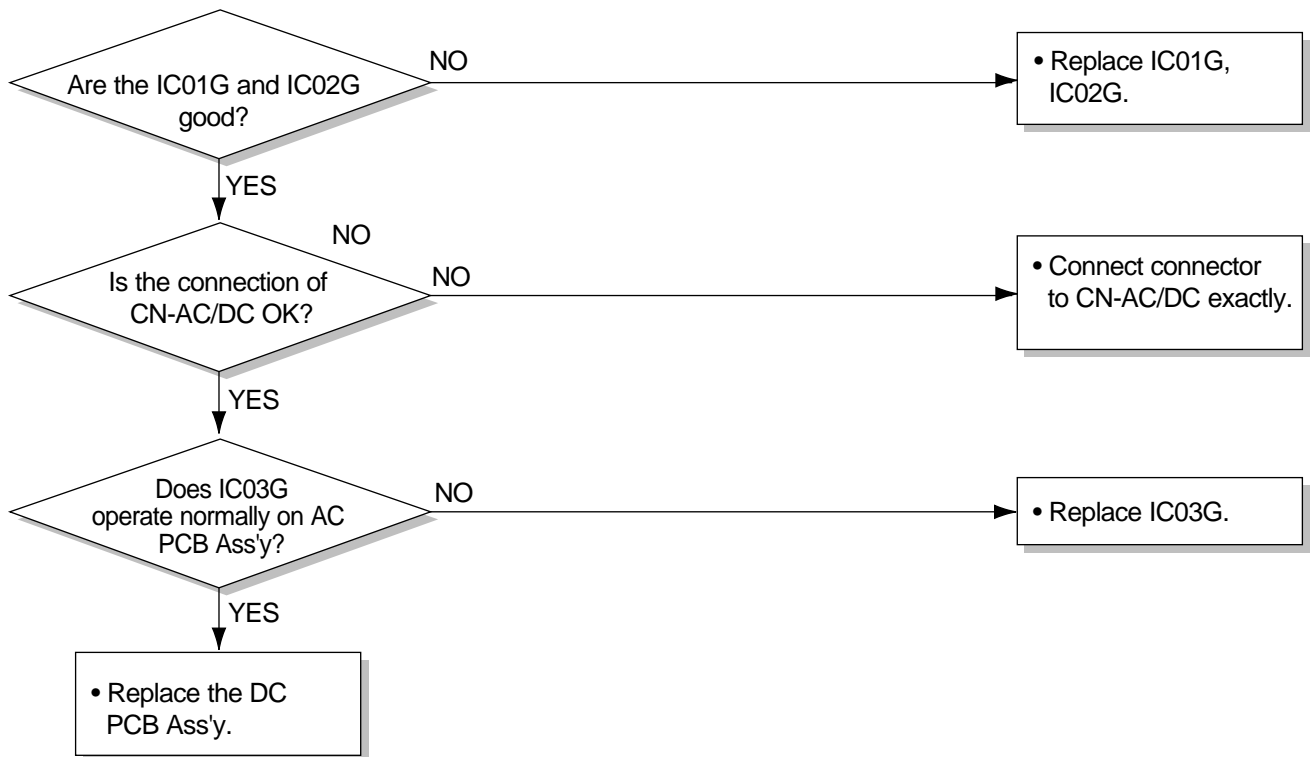

COMPLAINT	CAUSE	REMEDY
Fan motor will not run.	No power	Check voltage at outlet. Correct if none.
	Power supply cord	Check voltage to Control Box. If none, check power supply cord. Replace cord if circuit is open.
	Wire disconnected or connection loose	Connect wire. Refer to wiring diagram for terminal identification. Repair or replace loose terminal.
	Capacitor (Discharge capacitor before testing.)	Test capacitor. Replace if not within $\pm 10\%$ of manufacturer's rating. Replace if shorted, open, or damaged.
	Will not rotate	Fan blade hitting shroud or blower wheel hitting scroll. Realign assembly.  Units using slinger ring for condenser fan must have $\frac{1}{4}$ to $\frac{5}{16}$ inch clearance to the base. If it hits the base, shim up the bottom of the fan motor with mounting screw(s).  Check fan motor bearings; if motor shaft will not rotate, replace the motor.
Fan motor runs intermittently	Revolves on overload.	Check voltage. If not within limits, call an electrician.  Test capacitor. Check bearings. Does the fan blade rotate freely? If not, replace fan motor.  Pay attention to any change from high speed to low speed. If the speed does not change, replace the motor.
Fan motor noise.	Fan	If cracked, out of balance, or partially missing, replace it.
	Turbo	If cracked, out of balance, or partially missing, replace it.
	Loose clamper	Tighten it.
	Worn bearings	If knocking sounds continue when running or loose, replace the motor. If the motor hums or noise appears to be internal while running, replace motor.
Compressor will not run, but fan motor runs.	Voltage	Check voltage. If not within limits, call an electrician.
	Wiring	Check the wire connections, if loose, repair or replace the terminal. If wires are off, refer to wiring diagram for identification, and replace. Check wire locations. If not per wiring diagram, correct.

COMPLAINT	CAUSE	REMEDY
Compressor will not run, but fan motor runs.	Thermistor	Check the TEMP control. If not at the lowest number, set TEMP control to this setting and restart the unit. Check the continuity of the thermistor. Replace the thermistor if the circuit is open.
	Capacitor (Discharge capacitor before servicing.)	Check the capacitor. Replace if not within $\pm 10\%$ of manufacturers rating. Replace if shorted, open, or damaged.
	Compressor	Check the compressor for open circuit or ground. If open or grounded, replace the compressor.
	Overload	Check the compressor overload, if externally mounted. Replace if open. (If the compressor temperature is high, remove the overload, cool it, and retest.)
Compressor cycles on overload.	Voltage	Check the voltage. If not within limits, call an electrician.
	Overload	Check overload, if externally mounted. Replace if open. (If the compressor temperature is high, remove the overload, cool, and retest.)
Compressor cycles on overload.	Fan motor	If not running, determine the cause. Replace if required.
	Condenser air flow restriction	Remove the cabinet. inspect the interior surface of the condenser; if restricted, clean carefully with a vacuum cleaner (do not damage fins) or brush. Clean the interior base before reassembling.
	Condenser fins (damaged)	If condenser fins are closed over a large area on the coil surface, head pressures will increase, causing the compressor to overload. Straighten the fins or replace the coil.
Compressor cycles on overload.	Capacitor	Test capacitor.
	Wiring	Check the terminals. If loose, repair or replace.
	Refrigerating system	Check the system for a restriction.
Insufficient cooling or heating	Air filter	If restricted, clean or replace.
	Exhaust damper door	Close if open.
	Unit undersized	Determine if the unit is properly sized for the area to be cooled.
Excessive noise	Turbo or fan	Check the set screw or clamp. If loose or missing, correct. If the turbo or fan is hitting air guide, rearrange the air handling parts.
	Copper tubing	Remove the cabinet carefully and rearrange tubing not to contact cabinet, compressor, shroud, and barrier.



■ HEATING MODEL

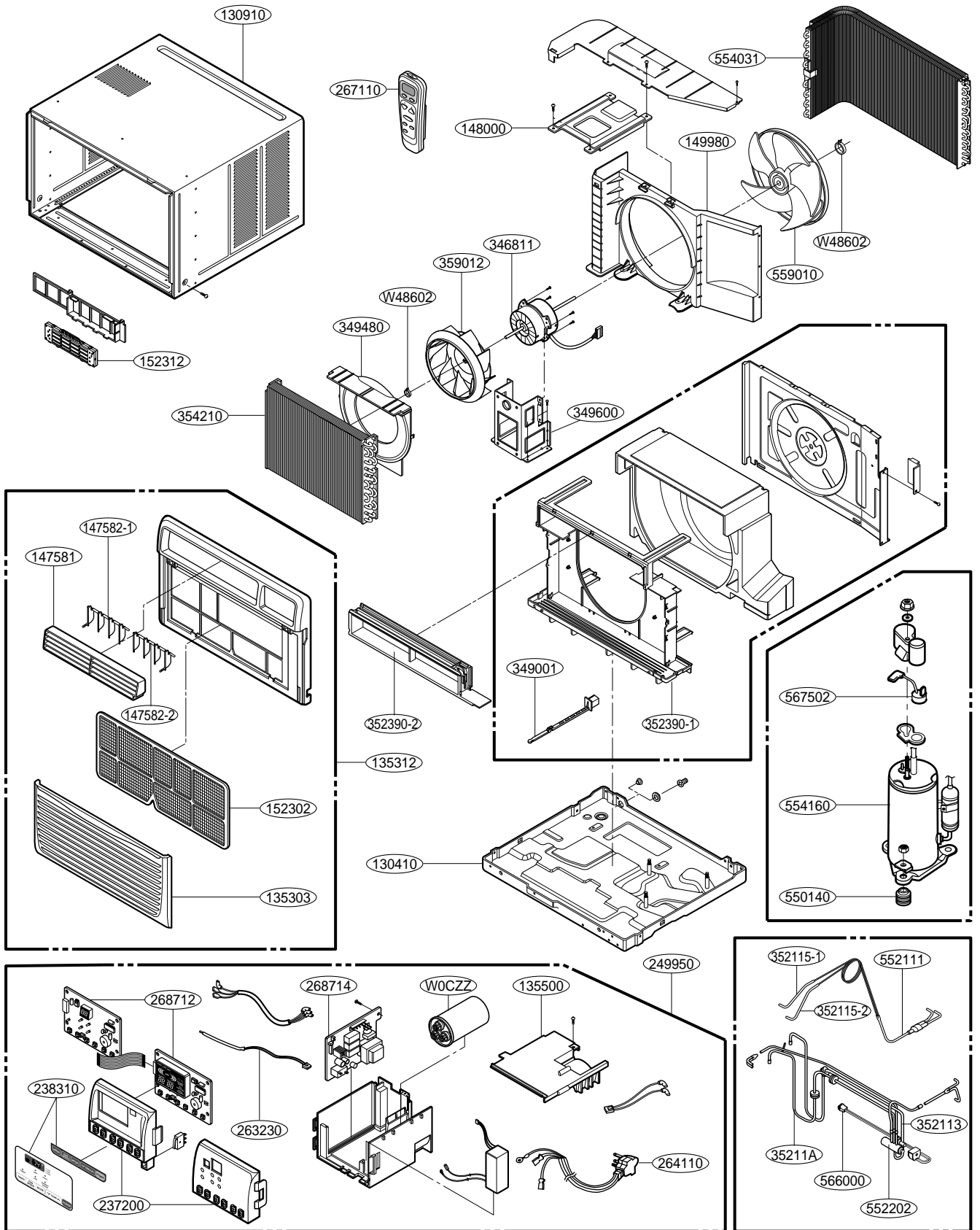

# Replacement Parts List

LOCATION NO.	DESCRIPTION	PART NO.	REMARK
		LW1800PRZ3	
130410	BASE ASSEMBLY,WELD[SINGLE]	3041A20023D	
130910	CABINET ASSEMBLY,SINGLE	3091AR6057E	
135303	GRILLE,INLET	3530A10080A	
135312	GRILLE ASSEMBLY,FRONT(SINGLE)	3531A20095A	
147581	LOUVER,HORIZONTAL	4758A30022A	
147582-1	LOUVER,VERTICAL	4758A20042A	
147582-2	LOUVER,VERTICAL	4758A20042B	
148000	BRACE	4800A20001A	
149980	SHROUD	4998A10013A	
152302	FILTER ASSEMBLY,AIR CLEANER	5231A20008A	
159830	AIR CLEANER ASSEMBLY	5983A10009K	
237200	PANEL,CONTROL	3720A10110A	
238310	ESCUTCHEON	3831A10020F	
249950	CONTROL BOX ASSEMBLY,SINGLE	4995A30010K	
263230	THERMISTOR ASSEMBLY	6323A20004E	
264110	POWER CORD ASSEMBLY	6411A20011K	
267110	REMOTE CONTROLLER ASSEMBLY	6711A20052A	
268712	PWB(PCB) ASSEMBLY,MAIN(DC)	6871A20323A	
268714	PWB(PCB) ASSEMBLY,MAIN(AC)	6871A20271B	
349001	DAMPER,VENTILATION	4900A20004A	
349480	ORIFICE	4948A30008A	
349600	MOUNT,MOTOR	4960AR2895B	
352113	TUBE ASSEMBLY,DISCHARGE SINGLE	5211A30066N	
35211A	TUBE ASSEMBLY,SUCTION(OUTDOOR)	5211A20441A	
352390-1	AIR GUIDE ASSEMBLY	5239A20002A	
352390-2	AIR GUIDE ASSEMBLY	5239A20003A	
354210	EVAPORATOR ASSEMBLY,FIRST	5421A20091A	
359012	FAN ASSEMBLY,TURBO	5901A20009A	
550140	ISOLATOR,COMP	4H00982C	
552111	TUBE ASSEMBLY,CAPILLARY	5211A30275R	
554031	CONDENSER ASSEMBLY,BENT	5403A20062B	
559010	FAN ASSEMBLY,AXIAL	5901A20010A	
567502	O.L.P	6750U-L016A	
W0CZZ	CAPACITOR,DRAWING	6120AR2194F	
W48602	CLAMP,SPRING	3H02932C	
W52106-1	TUBE,FORMED	5210A21099E	
W52106-2	TUBE,FORMED	5210A21099F	
554160	COMPRESSOR SET	2520UMKK2AA	
346811	MOTOR ASSEMBLY,SINGLE	4681A20011M	

Replacement Parts List

LOCATION NO.	DESCRIPTION	PART NO.			REMARK
		LWP1820PDL	LWC182PLMM0	LWC212PLMM0	
130410	BASE ASSEMBLY, WELD[SINGLE]	3041A20023B	3041A20023B	3041A20023Z	R
130910	CABINET ASSEMBLY, SINGLE	3091AR6057H	3091AR6057H	3091AR6057H	R
135303	GRILLE, INLET	3530A10080A	3530A10080A	3530A10080A	R
135312	GRILLE ASSEMBLY, FRONT(SINGLE)	3531A20095A	3531A20095D	3531A20095D	R
135500	COVER	3550A30122A	3550A20217A	3550A20217A	R
146812	MOTOR ASSEMBLY, SYNC.	-	2H01102A	2H01102A	R
147581	LOUVER, HORIZONTAL	4758A30022A	4758A30022A	4758A30022A	R
147582-1	LOUVER, VERTICAL	4758A30023A	5210A21099L	-	R
147582-2	LOUVER, VERTICAL	4758A30023B	5210A21099M	-	R
148000	BRACE	4800A20001A	4800A20001A	4800A20001A	R
149980	SHROUD	4998A10013A	4998A10013A	4998A10013A	R
152302	FILTER ASSEMBLY, AIR CLEANER	5231A20008A	5231A20008A	5231A20008A	R
152312	PLASMA FILTER ASS'Y	-	-	3720A10112A	R
237200	PANEL, CONTROL	3720A20156A	3720A10112A	3831A10021P	R
238310	ESCUTCHEON	3831A10023B	3831A10021P		R
249950	CONTROL BOX ASSEMBLY, SINGLE	4995A20194U	4995A20330B	4995A20330A	R
263230	THERMISTOR ASSEMBLY	6323A20004E	6323A20004E	6323A20004E	R
264110	POWER CORD ASSEMBLY	3H01307F	3H01307G	3H01307H	R
268712	PWB(PCB) ASSEMBLY, MAIN(DC)	6871A20187C	6871A20325C	6871A20325C	R
268714	PWB(PCB) ASSEMBLY, MAIN(AC)	6871A20167G	6871A20271C	6871A20271C	R
346811	MOTOR ASSEMBLY, SINGLE	4681AR6033V	4681AR6033V	4681A20081G	R
349001	DAMPER, VENTILATION	4900A20004A	4900A20004A	4900A20004A	R
349480	ORIFICE	4948A30008A	4948A30008A	4948A30008A	R
349600	MOUNT, MOTOR	4960AR1596A	4960AR1596A	4960AR1596A	R
352111	TUBE ASSEMBLY, CAPILLARY	-	5211A30275J	5211A30275V	
352113	TUBE ASSEMBLY, DISCHARGE SINGLE	5211A30066T	5211A30066T	5211A20805J	R
352115-1	TUBE FORMED, EVAPORATOR	5210A21099L	-	5210A21099X	R
352115-2	TUBE FORMED, EVAPORATOR	5210A21099M	-	5210A21099W	R
35211A	TUBE ASSEMBLY, SUCTION(OUTDOOR)	5211A20441D	5211A20441D	5211A20441H	R
352390-1	AIR GUIDE ASSEMBLY	5239A20002B	5239A20002B	5239A20002B	R
352390-2	AIR GUIDE ASSEMBLY	5239A20003B	5239A20003C	5239A20003C	R
354210	EVAPORATOR ASSEMBLY, FIRST	5421A20091D	5421A20091E	5421A20091C	R
359012	FAN ASSEMBLY, TURBO	5901A20009A	5901A20009A	5901A20009A	R
550140	ISOLATOR, COMP	4H00982C	4H00982C	-	R
552101	TUBE, CAPILLARY	-	5210A20556N	-	R
552111	TUBE ASSEMBLY, FORMED COND	5211AR3399R	-	-	R
554031	CONDENSER ASS'Y	5403A20004J	5403A20004K	5403A20062H	R
554160	COMPRESSOR SET	2520UMDK2DA	2520UMDK2DA	2520UHCK2AA	R
559010	FAN ASSEMBLY, AXIAL	5901A20010A	5901A20010A	5900AR1508A	R
567502	OVERLOAD PROTECTOR	-	-	-	R
W0CZZ	CAPACITOR, DRAWING	6120AR2194P	6120AR2194P	2A00986Y	R
W48602	CLAMP, SPRING	3H02932C	3H02932C	3H02932C	R
267110	REMOTE CONTROLLER ASSEMBLY	6711A20034Z	6711A20034F	6711A20034F	R

LOCATION NO.	DESCRIPTION	PART NO.			REMARK
		LW1500PRY3	LW1800ERZ3	LW1804ER	
130410	BASE ASSEMBLY, WELD[SINGLE]	3041A20023B	3041A20023C	3041A20023D	R
130910	CABINET ASSEMBLY, SINGLE	3091AR6057E	3091AR6057E	3091AR6057E	R
135303	GRILLE, INLET	3530A10080A	3530A10080A	3530A10080A	R
135312	GRILLE ASSEMBLY, FRONT(SINGLE)	3531A20095A	3531A20095A	3531A20095A	R
135500	COVER, CONTROL BOX	3550A30122A	3550A30122A	3550A20089A	R
146812	MOTOR ASSEMBLY, SYNC.	-	-	-	R
147581	LOUVER, HORIZONTAL	4758A30022A	4758A30022A	4758A30022A	R
147582-1	LOUVER, VERTICAL	4758A20042B	4758A20042B	4758A20042A	R
147582-2	LOUVER, VERTICAL	4758A20042A	4758A20042A	4758A20042B	R
148000	BRACE	4800A20001A	4800A20001A	4800A20001A	R
149980	SHROUD	4998A10013A	4998A10013A	4998A10013A	R
152302	FILTER ASSEMBLY, AIR CLEANER	-	-	5231A20008A	R
152312	FILTER ASSEMBLY, AIR CLEANER	5231A20008A	5231A20008A	-	R
237200	PANEL, CONTROL	5983A10009K	-	-	R
238310	ESCUTCHEON	6871A20271A	6871A20167D	-	R
249950	CONTROL BOX ASSEMBLY, SINGLE	3720A10110A	3720A10112A	4995A30010M	R
263230	THERMISTOR ASSEMBLY	6871A20323A	6871A20325A	6323A20004E	R
263230	THERMISTOR ASSEMBLY	6323A20004E	6323A20004E		R
264110	POWER CORD ASSEMBLY	6411A20011J	6411A20011K	6411A20011K	R
267110	REMOTE CONTROLLER ASSEMBLY	6711A20052A	6711A20034G		R
268712	PWB(PCB) ASSEMBLY, MAIN(DC)	4995A30010D	4995A20278L	6871A20323C	R
268714	PWB(PCB) ASSEMBLY, MAIN(AC)	3831A10020F	3831A10021M	6871A20167L	R
346811	MOTOR ASSEMBLY, SINGLE	4681AR6033X	4681A20011M	4681A20011M	R
349001	DAMPER, VENTILATION	4900A20004A	4900A20004A	4900A20004A	R
349480	ORIFICE	4948A30008A	4948A30008A	4948A30008A	R
349600	MOUNT, MOTOR	4960AR1596A	4960AR2895B	4960AR2895B	R
35211A	TUBE ASSEMBLY, SUCTION(OUTDOOR)	5211A20441C	5211A20441A	-	R
352111	TUBE, CAPILLARY	5211AR3399L	-	-	R
352113	TUBE ASSEMBLY, DISCHARGE SINGLE	-	-	5211A30066N	R
352115-1	TUBE FORMED, EVAPORATOR	5211A20215G	-	5210A21099A	R
352115-2	TUBE FORMED, EVAPORATOR	5211A20215H	-	5210A21099B	R
35211A	TUBE ASSEMBLY, SUCTION(OUTDOOR)			5211A20441A	R
352390-1	AIR GUIDE ASSEMBLY	5239A20002A	5239A20002A	5239A20002A	R
352390-2	AIR GUIDE ASSEMBLY	5239A20003A	5239A20003A	5239A20003A	R
354210	EVAPORATOR ASSEMBLY, FIRST	5421A20091A	5421A20091A	5421A20091A	R
359012	FAN ASSEMBLY, TURBO	5901A20009A	5901A20009A	5901A20009A	R
550140	ISOLATOR, COMP	4H00982C	4H00982C	4H00982C	R
552101	TUBE, CAPILLARY	-	-	5210A20492R	R
552111	TUBE ASSEMBLY, CAPILLARY	-	5211A30275R	5211A30275R	R
552113	TUBE ASSY, CONDENSER OUT	5211A30066R	5211A30066N	-	R
552116	TUBE ASSEMBLY, REVERSING	-	-	-	R
552202	VALVE, REVERSING	-	-	-	R
554031	CONDENSER ASSEMBLY, BENT	5403A20062B	5403A20062B	5403A20062B	R
554160	COMPRESSOR SET	2520UMTC2AA	2520UMKK2AA	2520UMKK2AA	R
559010	FAN ASSEMBLY, AXIAL	5901A20010A	5901A20010A	5901A20010A	R
561410	COIL ASSEMBLY, REVERSING VALVE	-	-	-	R
566000	SWITCH, PRESSURE	-	-	-	R
567502	O.L.P	-	6750U-L016A	6750U-L016A	R
W0CZZ	CAPACITOR, DRAWING	0CZZA20001L	6120AR2194F	6120AR2194F	R
W48602	CLAMP, SPRING	3H02932C	3H02932C	3H02932C	R
267110	REMOTE CONTROLLER ASSEMBLY	-	-	6711A20034G	R

Replacement Parts List

LOCATION NO.	DESCRIPTION	PART NO.				REMARK
		LW1800PR	LW1800ER	LW1500PR	LWP1830WAL	
130410	BASE PAN WELD ASS'Y	3041A20023B				R
130910	CABINET ASS'Y	3091AR6057E			3091AR6057H	R
135312	FRONT GRILL ASS'Y	3531A20095A			3531A20095B	R
135303	INLET GRILLE	3530A10080A				R
135500	COVER, CONTROL BOX	3550A30122A				R
147581	HORIZONTAL LOUVER	4758A30022A				R
147582-1	VERTICAL LOUVER	4758A30023A				R
147582-2	VERTICAL LOUVER	4758A30023B				R
148000	BRACE	4800A20001A				R
149980	SHROUD	4998A10013A				R
152302	AIR FILTER ASS'Y	5231A20008A				R
152312	PLASMA FILTER ASS'Y	5983A10009H	-	5983A10009H		R
237200	CONTROL PANEL	3720A20141A	3720A20156A	3720A20141A		R
249950	CONTROL BOX ASS'Y	4995A20194C	4995A20194J	4995A20194M	4995A20194R	R
268712	DISPLAY PCB ASS'Y	6871A20185A	6871A20187A	6871A20185A	6871A20185C	R
238310	ESCUTCHEON	3831A10020B	3831A10023A	3831A10020B		R
268714	MAIN PCB ASS'Y	6871A20167B	6871A20167D	6871A20167E	6871A20167B	R
263230	THERMISTOR ASS'Y	6323A20004E				R
264110	POWER CORD ASS'Y	6411A20011K		6411A20011J	6411A20011K	R
346811	MOTOR ASS'Y	4681AR6033V		4681AR6033X	4681AR6033V	R
349001	VENTILATION DAMPER	4900A20004A				R
349480	ORIFICE	4948A30008A				R
349600	MOUNT MOTOR	4960AR1596A				R
352111	TUBE ASS'Y CAPILLARY	5211AR3332Z		5211A30275F	5211AR3399L	R
352113	DISCHARGE TUBE	5211A30066N		5211A30066R	5211A30066N	R
W52106-1	TUBE FORMED, EVAPORATOR	5210A21099A			5210A21099E	R
W52106-2	TUBE FORMED, EVAPORATOR	5210A21099B			5210A21099F	R
35211A	SUCTION TUBE ASS'Y	5211A20441A		5211A20441C	5211A20441A	R
352390-1	AIR GUIDE ASSEMBLY	5239A20002A				R
352390-2	AIR GUIDE ASSEMBLY	5239A20003A				R
354210	EVAPORATOR ASS'Y	5421A20091A			5421A20091C	R
567502	OVERLOAD PROTECTOR	6750U-L025A		INTERNAL	6750U-L025A	R
550140	ANTI-VIBRATION BUSH	4H00982C				R
554031	CONDENSER ASS'Y	5403A20062B			5403A20062C	R
554160	COMPRESSOR	2520UMBK2EA		2520UMTC2AA	2520UMBK2EA	R
559010	FAN	5901A20010A				R
359012	TURBO FAN	5901A20009A				R
W48602	CLAMP, SPRING				3H02932C	R
W0CZZ	CAPACITOR	6120AR2194D		0CZZA20001L	6120AR2194D	R
267110	REMOTE CONTROLLER	6711A20052A	6711A20034G	6711A20052A	6711A20052D	R

LOCATION NO.	DESCRIPTION	PART NO.	REMARK
		LWP1820PEL	
130410	BASE ASSEMBLY, WELD[SINGLE]	3041A20023B	R
130910	CABINET ASSEMBLY, SINGLE	3091AR6057H	R
135303	GRILLE, INLET	3530A10080A	R
135312	GRILLE ASSEMBLY, FRONT(SINGLE)	3531A20095A	R
135500	COVER, CONTROL BOX	3550A30122A	R
147581	LOUVER, HORIZONTAL	4758A30022A	R
147582-1	LOUVER, VERTICAL	4758A30023A	R
147582-2	LOUVER, VERTICAL	4758A30023B	R
148000	BRACE	4800A20001A	R
149980	SHROUD	4998A10013A	R
152312	FILTER ASSEMBLY, AIR CLEANER	5231A20008A	R
237200	PANEL, CONTROL	3720A20156A	R
238310	ESCUTCHEON	3831A10023C	R
249950	CONTROL BOX ASSEMBLY, SINGLE	4995A20194T	R
263230	THERMISTOR ASSEMBLY	6323A20003P	R
263230	THERMISTOR ASSEMBLY	6323A20004E	R
264110	POWER CORD ASSEMBLY	3H01307F	R
267110	REMOTE CONTROLLER ASSEMBLY	6711A20034Z	R
268712	PWB(PCB) ASSEMBLY, MAIN(DC)	6871A20187B	R
268714	PWB(PCB) ASSEMBLY, MAIN(AC)	6871A20167F	R
346811	MOTOR ASSEMBLY, SINGLE	4681AR6033Y	R
349001	DAMPER, VENTILATION	4900A20004A	R
349480	ORIFICE	4948A30008A	R
349600	MOUNT, MOTOR	4960AR1596A	R
35211A	TUBE ASSEMBLY,SUCTION(OUTDOOR)	-	R
352111	TUBE, CAPILLARY	5425AR3147H	R
352115-1	TUBE FORMED, EVAPORATOR	5210A21099N	R
352115-2	TUBE FORMED, EVAPORATOR	5210A21099P	R
352390-1	AIR GUIDE ASSEMBLY	5239A20002C	R
352390-2	AIR GUIDE ASSEMBLY	5239A20003B	R
354210	EVAPORATOR ASSEMBLY, FIRST	5421A20091D	R
359012	FAN ASSEMBLY, TURBO	5901A20009A	R
550140	ISOLATOR, COMP	4H00982C	R
552111	TUBE ASSEMBLY,CAPILLARY		R
552113	TUBE ASSY, CONDENSER OUT	5211A30156B	R
552116	TUBE ASSEMBLY, REVERSING	5211A30157G	R
552202	VALVE, REVERSING	3A02027G	R
554031	CONDENSER ASSEMBLY, BENT	5403A20013R	R
554160	COMPRESSOR SET	2520UMDK2DA	R
559010	FAN ASSY, AXIAL	5900AR1330A	R
561410	COIL ASSEMBLY, REVERSING VALVE	3A02028K	R
566000	SWITCH, PRESSURE	6600AG3057B	R
567502	O.L.P	-	R
W0CZZ	CAPACITOR, DRAWING	6120AR2194P	R
W48602	CLAMP, SPRING	3H02932C	R

LOCATION NO.	DESCRIPTION	PART NO.		REMARK
		LW1804ER	LWC183PLMDI	
130410	BASE ASSEMBLY,WELD[SINGLE]	3041A20023D	3041A20023D	
130910	CABINET ASSEMBLY,SINGLE	3091AR6057E	3091AR6057E	
135303	GRILLE,INLET	3530A10080A	3530A10080A	
135312	GRILLE ASSEMBLY,FRONT(SINGLE)	3531A20095A	3531A20095A	
135500	COVER	3550A20089A	3550A30122A	
146812	MOTOR ASSEMBLY,SYNC.	-	-	
147581	LOUVER,HORIZONTAL	4758A30022A	4758A30022A	
147582-1	LOUVER,VERTICAL	4758A20042A	4758A20042A	
147582-2	LOUVER,VERTICAL	4758A20042B	4758A20042B	
148000	BRACE	4800A20001A	4800A20001A	
149980	SHROUD	4998A10013A	4998A10013A	
152302	FILTER ASSEMBLY,AIR CLEANER	5231A20008A	5231A20008A	
152312	PLASMA FILTER ASS'Y	-	-	
237200	PANEL,CONTROL	-	3720A10110A	
238310	ESCUTCHEON	-	3831A10020M	
249950	CONTROL BOX ASSEMBLY,SINGLE	4995A30010M	4995A30010M	
263230	THERMISTOR ASSEMBLY	6323A20004E	6323A20004E	
264110	POWER CORD ASSEMBLY	6411A20011K	6411A20011K	
267110	REMOTE CONTROLLER ASSEMBLY	6711A20034G	6711A20034G	
268712	PWB(PCB) ASSEMBLY,MAIN(DC)	6871A20323C	6871A20323C	
268714	PWB(PCB) ASSEMBLY,MAIN(AC)	6871A20167L	6871A20167L	
346811	MOTOR ASSEMBLY,SINGLE	4681A20011M	4681A20011M	
349001	DAMPER,VENTILATION	4900A20004A	4900A20004A	
349480	ORIFICE	4948A30008A	4948A30008A	
349600	MOUNT,MOTOR	4960AR2895B	4960AR2895B	
352113	TUBE ASSEMBLY,DISCHARGE SINGLE	5211A30066N	5211A30066N	
352115-1	TUBE,EVAPORATOR	5210A21099A	5210A21099A	
352115-2	TUBE,EVAPORATOR	5210A21099B	5210A21099B	
35211A	TUBE ASSEMBLY,SUCTION(OUTDOOR)	5211A20441A	5211A20441A	
352390-1	AIR GUIDE ASSEMBLY	5239A20002A	5239A20002A	
352390-2	AIR GUIDE ASSEMBLY	5239A20003A	5239A20003A	
354210	EVAPORATOR ASSEMBLY,FIRST	5421A20091A	5421A20091A	
359012	FAN ASSEMBLY,TURBO	5901A20009A	5901A20009A	
550140	ISOLATOR,COMP	4H00982C	4H00982C	
552101	TUBE,CAPILLARY	5210A20492R	5210A20492R	
552111	TUBE ASSEMBLY,CAPILLARY	5211A30275R	5211A30275R	
554031	CONDENSER ASSEMBLY,BENT	5403A20062B	5403A20062B	
554160	COMPRESSOR SET	2520UMKK2AA	2520UMKK2AA	
559010	FAN ASSEMBLY,AXIAL	5901A20010A	5901A20010A	
567502	O.L.P	6750U-L016A	6750U-L016A	
W0CZZ	CAPACITOR,DRAWING	6120AR2194F	6120AR2194F	
W48602	CLAMP,SPRING	3H02932C	3H02932C	

LOCATION NO.	DESCRIPTION	PART NO.	REMARK
		HBLG183R	
130410	BASE ASSEMBLY,WELD[SINGLE]	3041A20023D	
130910	CABINET ASSEMBLY,SINGLE	3091AR6057E	
135303	GRILLE,INLET	3530A10146A	
135312	GRILLE ASSEMBLY,FRONT(SINGLE)	3531A10201A	
135500	COVER	3550A30122A	
147581	LOUVER,HORIZONTAL	4758A30022A	
147582-1	LOUVER,VERTICAL	4758A20042A	
147582-2	LOUVER,VERTICAL	4758A20042B	
148000	BRACE	4800A20001A	
149980	SHROUD	4998A10013A	
152302	FILTER ASSEMBLY,AIR CLEANER	5231A20008A	
237200	PANEL,CONTROL	3720A10112A	
238310	ESCUTCHEON	3831A10021F	
249950	CONTROL BOX ASSEMBLY,SINGLE	4995A20194Y	
263230	THERMISTOR ASSEMBLY	6323A20004E	
264110	POWER CORD ASSEMBLY	6411A20011K	
267110	REMOTE CONTROLLER ASSEMBLY	6711A90019C	
268712	PWB(PCB) ASSEMBLY,MAIN(AC)	6871A20167D	
268714	PWB(PCB) ASSEMBLY,MAIN(DC)	6871A20325A	
346811	MOTOR ASSEMBLY,SINGLE	4681A20011M	
349001	DAMPER,VENTILATION	4900A20004A	
349480	ORIFICE	4948A30008A	
349600	MOUNT,MOTOR	4960AR2895B	
352111	TUBE,CAPILLARY BEND	5210A20492R	
352113	TUBE ASSEMBLY,DISCHARGE SINGLE	5211A30066N	
352390-1	AIR GUIDE ASSEMBLY	5239A20002A	
352390-2	AIR GUIDE ASSEMBLY	5239A20003A	
354210	EVAPORATOR ASSEMBLY,FIRST	5421A20091C	
359012	FAN ASSEMBLY,TURBO	5901A20009A	
550140	ISOLATOR,COMP	4H00982C	
554031	CONDENSER ASSEMBLY,BENT	5403A20062B	
554160	COMPRESSOR SET	2520UMKK2AA	
559010	FAN ASSEMBLY,AXIAL	5901A20010A	
35211A	TUBE ASSEMBLY,SUCTION(OUTDOOR)	5211A20441A	
W0CZZ	CAPACITOR,DRAWING	6120AR2194F	
W48602	CLAMP,SPRING	3H02932C	
W52106-1	TUBE,FORMED	5210A21099E	
W52106-2	TUBE,FORMED	5210A21099F	

