

FEDDERS

Room air conditioners for double hung windows

Acondicionadores de aire para ventanas de guillotina

Climatiseurs – Installation dans une fenêtre à guillotine

ENGLISH	
Important Safety Instructions	2
Installation	
Window installation	3
Operation	
Electronic controls	5
Cleaning the air filter	7
Service/Troubleshooting	7
Warranty	8

ESPAÑOL	
Instrucciones importantes de seguridad	9
Instalación	
Instalación en la ventana	10
Funcionamiento	
Controles electronicos	12
Limpieza del filtro del aire	14
Servicio/Localización y Solución de averías	14
Garantía	15

FRANÇAIS	
Directives de sécurité important	16
Installation	
Installation dans une fenêtre	17
Utilisation	
Commandes électronique	18
Nettoyage du filtre à air	20
Dépannage/Guide de diagnostic	20
Garantie	21

For Future Reference

Write down the model and serial numbers

The model and serial numbers can be found on the side of the cabinet near the control panel. Use these numbers in any correspondence or service calls concerning your air conditioner.

Para referencia futura

Escriba el número de modelo y de serie

El número de modelo y de serie se encuentran en el costado del gabinete cerca del panel de control. Use estos números en toda la correspondencia o llamadas de servicio relacionadas con su acondicionador de aire.

Pour consultation ultérieure

Inscrivez les numéros de modèle et de série

Noter ci-contre les numéros de modèle et de série (on les trouve sur le côté de la grille décorative avant, près du tableau de commande). Communiquer ces numéros lors de toute correspondance ou appel au service après-vente ayant trait au climatiseur.

Model No., No. de Modelo, N° de modèle

Serial No., No. de Serie, N° de série

Date of Purchase, Fecha de Compra, Date d'achat

Power Cord with Arc Detection Device

The power cord supplied with this air conditioner is equipped with an Arc Detection Device designed to shut off power to the unit when it senses an arc fault condition. An arc fault is an unintentional electrical discharge that occurs when electrical products or wires are damaged, aged, or improperly used. An arc fault can be potentially hazardous if left undetected.

⚠ WARNING ⚠

- **Do not** remove or modify this plug
- **Do not** use as an on/off switch
- **Do not** use outdoors
- **Do not** push furniture against or place furniture on the electrical cord. This can trip the test switch and/or damage the cord and become a potential condition for arcing
- Do not attempt to repair the cord. If the cord requires replacement, call an authorized servicer.
- The Arc Detection Device is not a Ground Fault Interrupter and should not be used as such
- The Arc Detection Device contains an electronic circuit board and should not be submerged or exposed to water spray

Resetting

If the Arc Detection Device has tripped, the reset button will pop up.

Follow these steps to reset the Arc Detection Device:

1. Unplug unit from electrical outlet
2. Press the reset button
3. Plug the unit back into electrical outlet
4. Check to see if power has returned to the unit

Testing

You should test the Arc Detection Device equipped power cord monthly, after every major electrical storm, or if power to your Room Air Conditioner has been interrupted.

Follow these steps to test the Arc Detection Device:

1. Unplug unit from electrical outlet
2. Press the reset button
3. Plug the unit back into electrical outlet
4. Press test button. Unit should trip and reset button will pop up.
5. Press reset button again for use

If above test fails, stop using the air conditioner and contact customer service by calling the following toll-free number:

1-800-332-6658

or email: customerservice@fedders.com

⚠ Warning ⚠

Electrical Shock Hazard

- Plug unit **only** into a grounded electrical outlet. 
- **Do not** use an extension cord or plug adapter with this unit.
- **Do not** operate unit with decorative front or filter removed.
- **Failure to follow these precautions could result in electrical shock, fire or personal injury.**
- **If the air conditioner has a serial plate rating of 115 volts and greater than 7.5 amps, it must have its own fuse or circuit breaker, and no other device or unit should be operated on that fuse or circuit breaker.**
- **If the air conditioner has a serial plate rating of 230 volts, it must have its own fuse or circuit breaker, and no other device or unit should be operated on that fuse or circuit breaker.**
- We recommend that a qualified electrician install unit in accordance with the National Electrical Code and local codes and ordinances.
- Use copper conductors of correct wire gauge and protector size only.
- Do not alter cord or plug end. Do not remove warning label on cord.

Important Grounding Requirements

- Air conditioner has a three-prong grounding plug on the power supply cord, which must be plugged into a properly grounded three-prong wall receptacle for your protection against possible shock hazard. For models up to and including 7.5 amperes, use a grounding type wall receptacle to match the cord plug.
- For models above 7.5 amperes use a single outlet grounding type wall receptacle to match the cord plug.

⚠ Warning ⚠

Do not operate this air conditioner without proper time delay circuit protection (circuit breaker or fuse). Refer to serial plate for proper power supply requirements.

Recommended Wire Sizes (As installed per building code) :

PROTECTOR SIZE WIRE GAUGE

15 AMP #14 MINIMUM

20 AMP #12 MINIMUM

30 AMP #10 MINIMUM



125V
15A



250V
20A



250V
15A



250V
30A

Additional Safety Precautions

- **Do not** cut, alter or remove any of the expanded polystyrene (styrofoam) inside this air conditioner.
- **Do not** store or use gasoline or other flammable vapors and liquids in the vicinity of this or any other appliance. The fumes can create a fire hazard or explosion.
- **Do not** introduce objects in the air discharge area. This could cause permanent damage.
- **Do not** pour liquids on the air conditioner as this could cause a malfunction. With the unit unplugged, use a damp cloth for cleaning the unit.
- **Do not** use strong solvents to clean the air conditioner.
- Clean the air conditioner filter every two weeks to avoid overheating caused by air obstruction. Do not operate without filter.
- **Do not** obstruct the air intake area of your air conditioner, as this could cause overheating, thus activating the unit's security switch and shutting off the unit.
- **Do not** block air circulation to outside louvers of cabinet.
- **Do not** block air flow inside with blinds, curtains, or furniture, or outside with shrubs, enclosures, or other buildings.
- **Do not** run the air conditioner with an outside protective cover in place. This could result in fire or mechanical damage within the air conditioner.
- Depending on the model, your air conditioner may weigh as much as 95 pounds. To insure safe handling, obtain the necessary help to lift and position the unit during installation and removal.
- Handle air conditioner with care. Wear protective gloves whenever lifting or carrying the unit.
- Carefully inspect the location where the air conditioner will be installed. Be sure it will support the weight of the unit over an extended period of time.

Tools Needed

- Screwdrivers
- Ruler or tape measure
- Level
- Pencil

Window Requirements

1. Air conditioner is factory prepared for installation in standard double hung window (air conditioner cannot be installed in other types of windows without modification, consult with a qualified installation serviceman).
2. Install the air conditioner in a window where there will be enough clearance around the cabinet to allow ample circulation of air through the unit.
3. All supporting parts should be secured to firm wood, masonry or metal.

Unit & Window Size

1. If your air conditioner cabinet is 20" wide, it will fit window openings 23 7/8" to 39" in width. Minimum opening height is 12 3/4" from bottom of sash to sill. Removal of both filler panels permits installation in windows with a minimum opening width of 20 1/4". This size unit requires one leveling bracket (*Fig. 1*).
2. If your air conditioner cabinet is 23 3/4" wide, it will fit window openings 27 5/8" to 39" in width. Minimum opening height is 16" from bottom of sash to sill. Removal of both filler panels permits installation in windows with a minimum opening width of 24". This size unit requires two leveling brackets (*Fig. 2*).

Attach Filler Panels *On some models...*

1. Attach filler panels to the existing holes in the cabinet using the supplied screws (*Fig. 3*).

Installation in Normal Width Window

1. Open and mark center line of window. Depending on the size of your unit, attach one leveling bracket on the center line of the window or one 8" to the right and one 8" to the left of the center line. Brackets may be attached to window sill in either direction for maximum support, depending on the depth of the window sill.
2. Mark line 1 1/4" from edge of window sill and fasten leveling bracket with 1" long wood screws at mark through larger holes in bracket (*Fig. 4*).
3. Screw leveling bolt in 3/8" threaded hole of leveling bracket and adjust so bolt is 1/4" below top of window sill (*Fig. 5*).
4. Repeat steps 2 and 3 for second leveling bracket, if required.

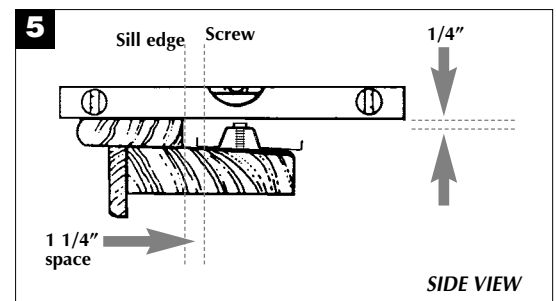
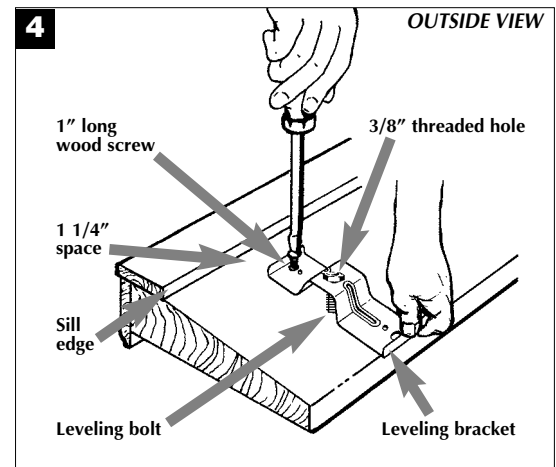
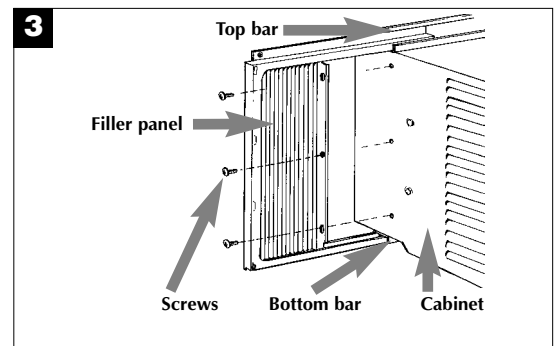
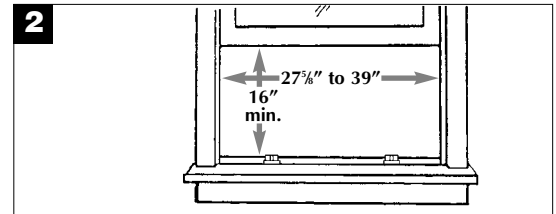
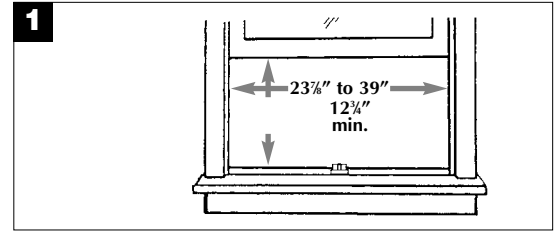

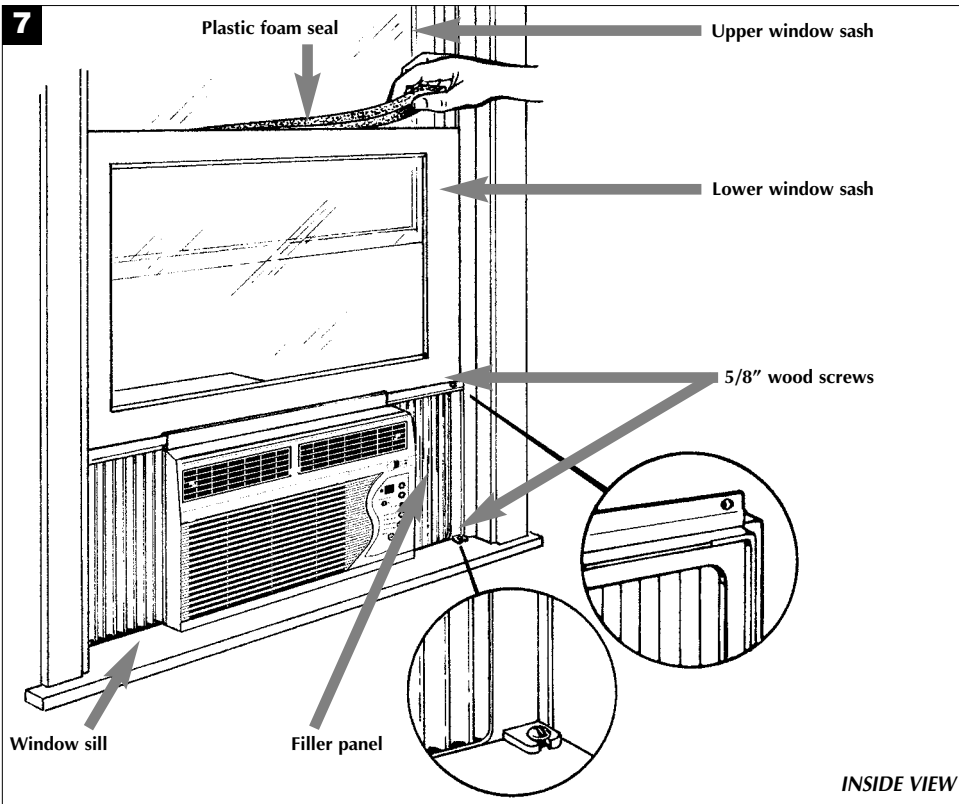
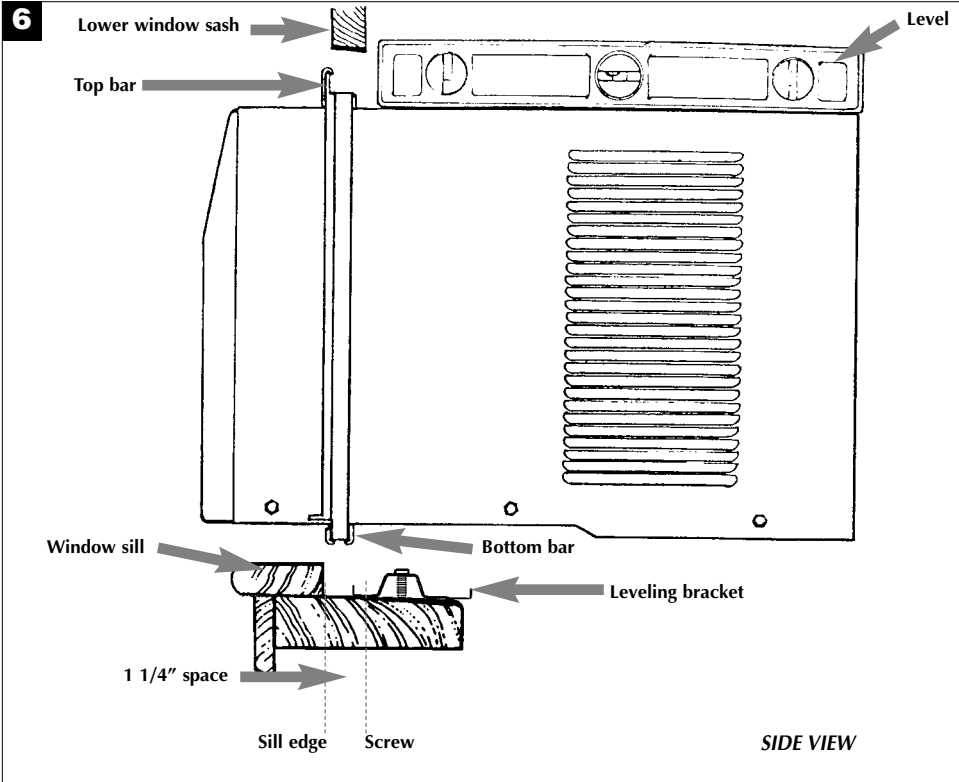

5. Keeping a firm grip on air conditioner, carefully center air conditioner in window opening with the bottom bar sitting behind window sill. Be sure cabinet maintains an outward pitch. Air conditioner should slant slightly downward on the outside as shown by half a bubble off on a carpenter's level. This outward pitch prevents water from entering the room (Fig. 6).
6. Close window until it touches behind air conditioner top bar. Slide filler panels outward until they touch window sash tracks. (Do not release grip on air conditioner until lower window sash is in final position) (Fig. 7).
7. Secure top of filler panels by driving 5/8" long wood screws through top mounting holes into window sash (Fig. 7).
8. Secure bottom of filler panels by driving 5/8" long screws into window sill through filler panel tabs (Fig. 7).
9. Cut plastic foam seal to width of window and install between upper and lower window sash (Fig. 7).
10. Use sealant to fill any minor openings.

Installation in Minimum Width Window

1. Remove both filler panels from air conditioner cabinet (Fig. 3).
2. Refer to steps 1 through 7 of preceding instructions (Pgs. 4 & 5).
3. Close window until it touches behind air conditioner top bar (Fig. 6).
4. Fasten lower window sash to window frame (use finishing nails, wood screws, or "L" brackets) (Fig. 7).
5. If filler is required on sides of air conditioner, cut plastic foam seal to size and fill both sides.
6. Cut plastic foam seal to width of window and install between upper and lower window sash (Fig. 7).
7. Use sealant to fill any minor openings.

Consult your authorized dealer or importer for alternative installation instructions.

⚠ CAUTION ⚠

Do not drill a hole in bottom pan. Unit is designed to operate with approximately 1/2" of water in bottom pan.

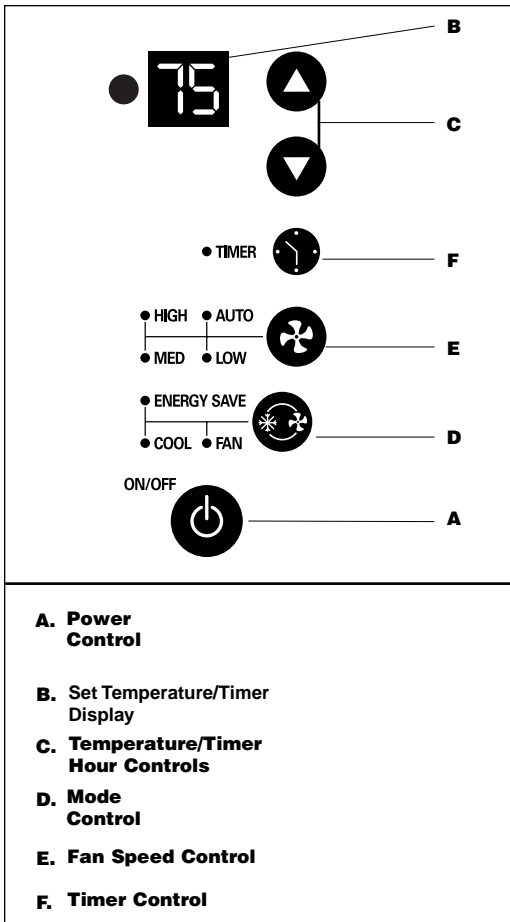

Built-in three minute timing delay.

If this electronic unit will not respond to touch pad or remote control commands, it is necessary to unplug the unit from the electrical outlet for five seconds and then plug the unit back in.

Auto restart feature:

In the event of a power failure, this feature allows the unit to resume operation once power has been restored, retaining the most recent settings. Upon restoration of power, the timer mode may need to be reset if being utilized.



CAUTION



Heat/Cool models or units with electric heat are designed to be used only as a supplemental heat source. They should be used in addition to regular heating systems and never as the primary source of heat.

Power Control

The Power Control turns the unit on and off.

Set Temperature/Timer Display

Shows the set temperature when the unit is in operation and hours when the timer is being set. *THE TEMPERATURE DISPLAY ONLY SHOWS THE SET TEMPERATURE, NOT THE ACTUAL ROOM TEMPERATURE.*

Temperature/Timer Hour Controls

These buttons are used to raise or lower the set temperature in increments of 1° from 66°F to 88°F. By depressing both buttons at once, the display will toggle between Celsius and Fahrenheit. When the timer is being set, these buttons are used to change the hour setting in increments of 1 from 00 to 24.

Check Filter Light/Reset (some models)

After 250 hours of usage the Check Filter light will turn on. At this time, the filter needs to be removed and cleaned (see page 8). After the filter is cleaned and repositioned, depress the Reset button. This will restart the counter and turn the light off.

Mode Control

A green light will indicate which mode is currently being utilized.

Cool Mode – The unit will circulate and cool the air.

Heat Mode (Heat Models Only)– The unit will circulate and heat the air.

Heater Safety Feature- When heater is powered off, low fan will automatically stay on and run for 60 seconds to ensure the removal of residual heat, meanwhile, the Low Fan LED blinks until the low fan stops.

Fan Mode – The unit will only circulate the air.

Energy Saver Mode –

(The energy saver mode is designed to operate with Cool mode only)

The fan will switch from the set fan speed to LO whenever the compressor turns off in response to the thermostat. When the compressor cycles back on, the unit will return to the original fan setting.

Fan Speed Control

High, Medium*, Low and Auto

The settings are adjusted with the Fan Speed Control, each time the button is depressed it changes the setting. A green light will indicate which setting is currently being used.

When the AUTO feature is selected while the air conditioner is in the COOL or HEAT mode, the fan speeds will change automatically as the temperature in the room changes.

COOL Mode

- 7° or more above the set temperature will use HI FAN.
- 4° or less above the set temperature will use LO FAN.

HEAT Mode (Heat models only)

- 9° or more below the set temperature will use HI FAN.
- 4° or less below the set temperature will use LO FAN.

*MEDIUM FAN NOT available on HEAT models.

Timer Control

The timer can be set to either turn the unit on or off.

To turn the unit on using the Timer:

Depress the timer key when the power is off, the display will read 00. Adjust to the desired number of hours before TURN ON using the up/down arrows.

- The display will show the time by hours left until TURN ON.
- To Turn the timer off, depress the timer key.
- A green light next to the Timer Control indicates that the timer is set.

To turn the unit OFF using the Timer:

Depress the timer key when the power is on, the display will read 00. Adjust to the desired number of hours before TURN OFF using the up/down arrows. The display will automatically go back to the set temperature after 10 seconds.

- To display the amount of time left until TURN OFF, depress the timer button once.
- To turn the TIMER OFF, depress the timer button twice.
- A green light next to the Timer Control indicates that the timer is set.

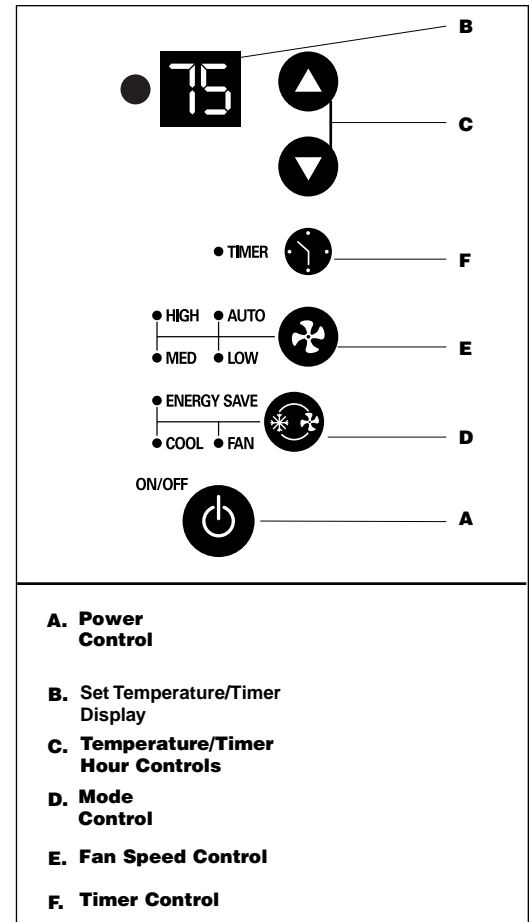

Air Conditioner Remote Control

The functions work the same as your air conditioner's touch controls.

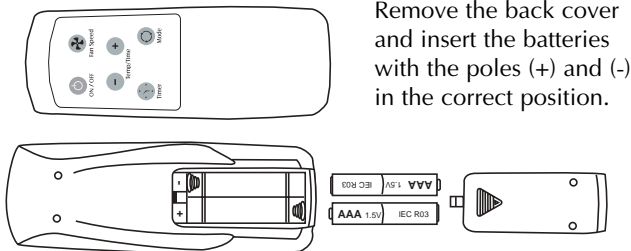

CAUTION

- Use only AAA or IEC R03 1.5V batteries.
- Remove the batteries if the remote controller is not used for a month or longer.
- Do not attempt to recharge the supplied batteries
- All batteries should be replaced at the same time.
- Do not dispose of the batteries in a fire as they may explode.
- Do not mix old and new batteries.
- Do not mix alkaline, standard (carbon - zinc), or rechargeable (nickel-cadmium) batteries.
- Do not install the batteries with the polarity (+/-) reversed.
- Keep batteries and other things that could be swallowed away from young children. Contact a doctor immediately if an object is swallowed.

Directing Airflow

Unit is engineered with adjustable louvers to direct discharge airflow. Louvers are manually adjusted by moving levers in direction of desired airflow (*Fig. 8*).

Cleaning Air Filter

Clean the filter every two weeks

1. Turn unit OFF.
2. Remove the air filter by grasping the top corners and pulling it up and out of the unit (*Fig. 8*).
3. Wash in hot soapy water, rinse and shake dry.
4. Replace the filter, with the front of the filter toward you.
5. To dry the filter thoroughly, run your unit for a few minutes. Remember, only a clean filter works properly and delivers top performance.

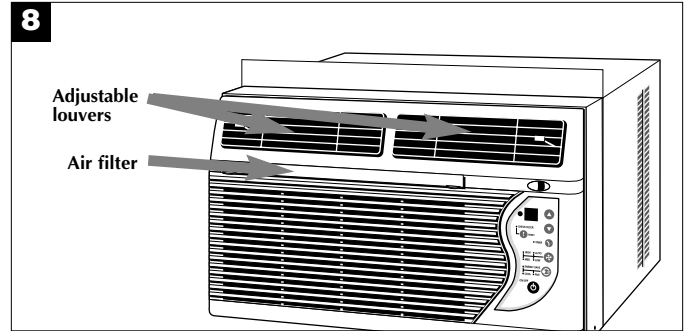

Proper use and care of your air conditioner will help ensure longer life of the unit. It is recommended to annually inspect and clean the coils and condensate water passages. Expense of annual inspection is the consumers' responsibility.

CAUTION

Failure to keep air filter clean will result in poor air circulation. DO NOT operate without filter. This can render the unit inoperative.

CAUTION

Before cleaning or servicing this unit, it is recommended that the unit be disconnected from any electrical supply outlet.

Troubleshooting Guide

Occurrence	Possible Cause	Solutions
Air conditioner will not operate	<ul style="list-style-type: none"> • Wall plug disconnected. • House fuse blown or circuit breaker tripped. • Power control in OFF position. • Unit accidentally turned off by moving the thermostat to a higher temperature and then immediately turned back to a colder position. • Unit turned off and then on too quickly. • Thermostat set too low for cooling. 	<ul style="list-style-type: none"> ✓ Push plug firmly into wall outlet. ✓ Replace fuse with time delay type or reset circuit breaker. ✓ Turn power control to ON. ✓ Wait approximately 3 minutes. Listen for the compressor to start. ✓ If air conditioner is turned off, wait 3 minutes before restarting. ✓ Adjust thermostat to higher setting for cooling.
Air from unit does not feel cold enough	<ul style="list-style-type: none"> • Selector in fan position. • Thermostat set too warm. • Room temperature below 70°F. 	<ul style="list-style-type: none"> ✓ Set mode to cool position. ✓ Set thermostat to colder temperature. ✓ Cooling may not occur until room temperature rises above 70°F.
Air conditioner cooling, but room is too warm — ice forming on cooling coil behind decorative front	<ul style="list-style-type: none"> • Outdoor temperature below 70°F. • Dirty air filter — air restricted. • Thermostat set too cold for nighttime cooling. 	<ul style="list-style-type: none"> ✓ To defrost the coil, set selector to FAN position. Then, set thermostat to warmer position. ✓ Clean filter. See "Cleaning the Air Filter" section. To defrost, set selector to FAN. ✓ To defrost the coil, set selector to FAN position.
Air conditioner cooling, but room too warm — NO ice forming on cooling coil behind decorative front	<ul style="list-style-type: none"> • Dirty air filter — air restricted. • Thermostat set too warm. • Fan selector set on LOW. 	<ul style="list-style-type: none"> ✓ Clean air filter. Refer to "Cleaning the air filter" section (above). ✓ Set thermostat to colder setting. ✓ Set fan speed selector to HIGH for maximum cooling.
Noise when unit is cooling	<ul style="list-style-type: none"> • Air movement sound. • Sound of fan hitting water-moisture removal system. • Window vibration — poor installation. 	<ul style="list-style-type: none"> ✓ The sound of rushing air is normal. If too loud, turn selector to lower fan setting. ✓ This is normal when humidity is high. Close doors, windows and registers. ✓ Refer to installation instructions — check with installer.
Water dripping inside when unit is cooling	<ul style="list-style-type: none"> • Improper installation. 	<ul style="list-style-type: none"> ✓ Tilt air conditioner slightly to the outside to allow water drainage. Refer to installation instructions — check with installer.
Water dripping outside when unit is cooling	<ul style="list-style-type: none"> • Unit removing large quantity of moisture from humid room. 	<ul style="list-style-type: none"> ✓ This is normal during excessively humid days.

How to Obtain Warranty Service or Parts

Note: Before calling for service, carefully read this Installation and Operations manual.

For Models Installed in North America :

First make the recommended checks in the Troubleshooting guide. Then, if you still need assistance:

1. Call a CareCo authorized servicer and advise them of model number, serial number, date of purchase and nature of complaint. Service will be provided during normal working hours. Contact your dealer for the name of an authorized servicer, if unknown to you.
2. If your dealer is unable to give you the name of a servicer or if you need other assistance, contact CareCo for the name of an authorized servicer.

You may contact CareCo by email:

customerservice@fedders.com

by calling the following toll-free number:

1-800-332-6658

or you may write:

CareCo, Service Department

415 W. Wabash Ave., P.O. Box 200

Effingham, IL 62401

For Models Installed Outside North America :

For room air conditioners purchased for use outside North America, the manufacturer does not extend any warranty either expressed or implied. Consult your local dealer for any warranty terms extended by the importer in your country.

Proof of Purchase Date

It is the responsibility of the consumer to establish the original purchase date for warranty purposes. We recommend that a bill of sale, cancelled check, or some other appropriate payment record be kept for that purpose.

Room Air Conditioner Warranty

(Within the 48 contiguous United States, state of Hawaii, the District of Columbia, Puerto Rico, Mexico and Canada)

Full (Five Year) Parts and Labor Warranty

During the five years after the date of original purchase, Fedders will, through its authorized servicers and free of charge to the owner or any subsequent user, repair or replace any parts which are defective in material or workmanship due to normal use. Ready access to the air conditioner is the responsibility of the owner.

Note: In the event of any required parts replacement within the period of this warranty, Fedders replacement parts shall be used and will be warranted only for the period remaining on the original warranty.

Exceptions

The above warranty does not cover failure to function caused by damage to the unit while in your possession (other than damage caused by defect or malfunction), or by its improper installation, or by unreasonable use of the unit, including without limitation, failure to provide reasonable and necessary maintenance or to follow the written Installation and Operating Instructions. If the unit is put to commercial, business, rental, or other use or application other than for consumer use, we make no warranties, express or implied, including but not limited to, any implied warranty of merchantability or fitness for particular use or purpose.

THE REMEDIES PROVIDED FOR IN THE ABOVE EXPRESS WARRANTY ARE THE SOLE AND EXCLUSIVE REMEDIES THEREFOR, NO OTHER EXPRESS WARRANTIES ARE MADE. ALL IMPLIED WARRANTIES, INCLUDING BUT NOT LIMITED TO ANY IMPLIED WARRANTY OF MERCHANTABILITY OR FITNESS FOR A PARTICULAR USE OR PURPOSE, ARE LIMITED IN DURATION TO FIVE YEARS FROM THE DATE OF ORIGINAL PURCHASE. IN NO EVENT SHALL FEDDERS BE LIABLE FOR INDIRECT, INCIDENTAL, OR CONSEQUENTIAL DAMAGES, EVEN IF ADVISED IN ADVANCE OF THE POSSIBILITY OF SUCH DAMAGES. NO WARRANTIES, EXPRESS OR IMPLIED, ARE MADE TO ANY BUYER UPON RESALE.

Some states do not allow limitations on how long an implied warranty lasts or do not allow the exclusion or limitation of incidental or consequential damages, so the above limitations or exclusions may not apply to you. This warranty gives you specific legal rights, and you may also have other rights which may vary from state to state.