



Website: <http://www.LGService.com>  
E-mail: <http://www.LGService.com/techsup.html>

# WASHING MACHINE SERVICE MANUAL

## **▲ CAUTION**

READ THIS MANUAL CAREFULLY TO DIAGNOSE  
PROBLEMS CORRECTLY BEFORE SERVICING THE UNIT.

**MODEL: WM2455H\***



MAR. 2007 PRINTED IN KOREA

P/No.: MFL30599107

---

# CONTENTS

1. SPECIFICATIONS .....	3
2. FEATURES & TECHNICAL EXPLANATION .....	4
3. PARTS IDENTIFICATION .....	7
4. INSTALLATION & TEST .....	8
5. OPERATION .....	11
6. WIRING DIAGRAM/PROGRAM CHART .....	14
7. TROUBLESHOOTING .....	15
7-1. BEFORE PERFORMING SERVICE .....	15
7-2. QC TEST MODE .....	15
7-3. HOW TO CHECK THE WATER LEVEL FREQUENCY .....	15
7-4. ERROR DISPLAY .....	16
8. ERROR DIAGNOSIS AND CHECK LIST .....	18
8-1. DIAGNOSIS AND SOLUTION FOR ABNORMAL OPERATION .....	18
8-2. FAULT DIAGNOSIS AND TROUBLESHOOTING .....	21
9. DISASSEMBLY INSTRUCTIONS .....	29
10. EXPLODED VIEW .....	40
10-1. CABINET & CONTROL PANEL ASSEMBLY .....	40
10-2. DRUM & TUB ASSEMBLY .....	41
10-3. DISPENSER ASSEMBLY .....	42

# 1. SPECIFICATIONS

ITEM		WM2455H*
COLOR		W:BLUE WHITE, G:PEARLY GRAY
POWER SUPPLY		AC 120 V, 60 Hz
PRODUCT WEIGHT		192 lbs (87kg)
ELECTRIC POWER CONSUMTION	WASHING	280 W
	DRAIN MOTOR	80 W
	WASH HEATER	1000 W
REVOLUTION SPEED	WASH	46 rpm
	SPIN	0-1200 rpm
CYCLES		9
WASH/RINSE TEMPERATURES		5
SPIN SPEEDS		4
OPTIONS		Prewash, Rinse+Spin, Extra Rinse, Water Plus, Stain Cycle
WATER CIRCULATION		–
OPERATIONAL WATER PRESSURE		14.5–116 psi (100-800 kPa)
CONTROL TYPE		Electronic
WASH CAPACITY [cu.ft]		3.47 (4.0 IEC)
DIMENSIONS		27" (W) X 29 <sup>3</sup> / <sub>4</sub> " (D) X 38 <sup>11</sup> / <sub>16</sub> " (H), 50 <sup>13</sup> / <sub>16</sub> " (D, door open)
DELAY WASH		up to 19 hours
DOOR SWITCH TYPE		PTC + Solenoid
WATER LEVEL		10 steps (by sensor)
LAUNDRY LOAD SENSING		Incorporated
ERROR DIAGNOSIS		Incorporated
AUTO POWER OFF		Incorporated
CHILD LOCK		Incorporated
RLM ENABLE		–
STEAM		–

## 2. FEATURES & TECHNICAL EXPLANATION

---

### 2-1. FEATURES

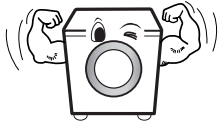

- **Ultra Capacity**

The Larger drum enables not just higher head drop and stronger centrifugal force, but also less tangling and wrinkling of the laundry. Heavier loads, such as king size comforters, blankets, and curtains, can be washed.



- **Direct Drive System**

The advanced Brushless DC motor directly drives the drum without belt and pulley.

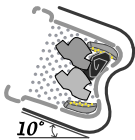

- **Tilted Drum and Extra Large Door Opening**

Tilted drum and extra large opening make it possible to load and unload clothing more easily.

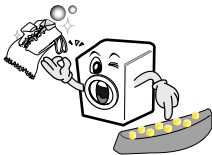

- **RollerJets**

Washing ball enhances the wash performance and reduces damage to the clothing. The jets spray and help tumble clothes to enhance washing performance while maintaining fabric care.

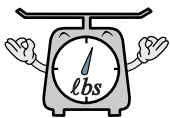

- **Automatic Wash Load Detection**

Automatically detects the load and optimizes the washing time.



- **Built-in Heater**

Internal heater helps to maintain water temperature at its optimum level for selected cycles.



- **Child Lock**

The Child lock prevents children from pressing any button to change the settings during operation.

---

## 2-2. NEURO FUZZY WASHING TIME OPTIMIZATION

To get the best washing performance, optimal time is determined by the water temperature, the selected washing temperature, and the size of the load.

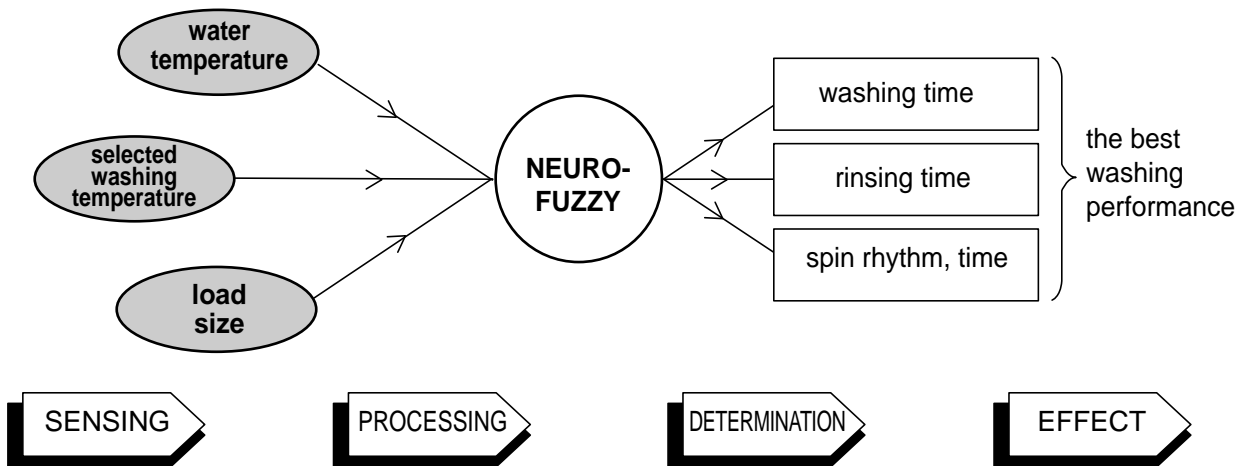

## 2-3. WATER LEVEL CONTROL

- This model incorporates a pressure sensor which can sense the water level in the tub.
- The water supply is stopped when the water level reaches the preset level, the washing program then proceeds.
- Spinning does not proceed until the water in the tub drains to a certain level.

## 2-4. DOOR CONTROL

- The door can be opened by pulling the door handle whenever washer is not in operation.
- When the cycle is completed, the DOOR LOCKED light will turn off.
- If a power failure has occurred while in operation, the door will unlock after 5 minutes.
- Clicking sounds can be heard when the door is locked/unlocked.

---

## 2-5. THE DOOR CAN NOT BE OPENED

- While program is operating
- When a power failed and power plug is taken out in operation
- While Door Lock lights turn on.
- While the motor is in the process of inertial rotating, through the operation is paused.

## 2-6. DOOR LOCKED LAMP LIGHTS

- When the frequency of water level is lower than 22.9 kHz  
(It can be canceled when the frequency is more than 23.8 kHz)
- When the temperature inside the tub is higher than 45 °C and water level is not 25.5 kHz  
(It can be canceled when the water level is 25.5 kHz or the temperature inside the tub is lower than 40 °C)

## 2-7. CHILD LOCK

- Use this option to prevent unwanted use of the washer. Press and hold PRE WASH button for 3 seconds to lock/unlock control.
- When Child lock is set, CHILD LOCK lights and all buttons are disabled except the Power  button. You can lock the washer while it is operating.

# 3. PARTS IDENTIFICATION

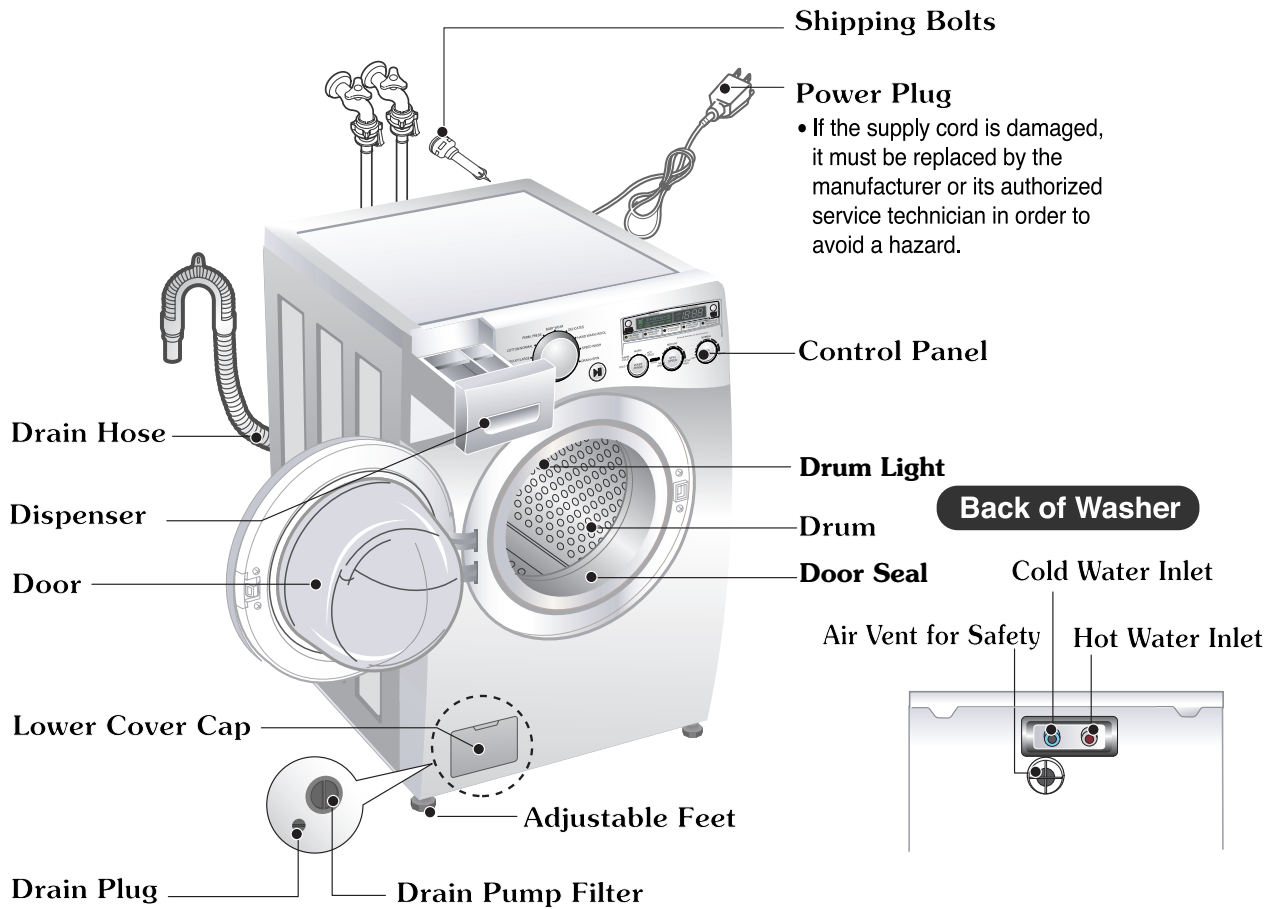

## ■ ACCESSORIES

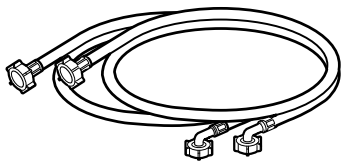

**Hot/Cold (1 each)  
Hose**

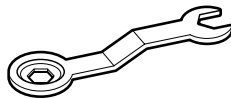

**Wrench**  
for removing shipping bolts  
and leveling the washer



**Tie strap**  
to secure drain hose to standpipe,  
inlet hose, or laundry tub

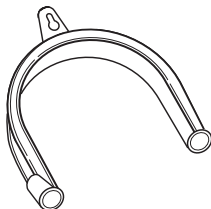

**Hose retainer**



**Cap (4 each)**  
to cover the holes created after  
removing the shipping bolts



# 4. INSTALLATION & TEST

- 1 Before servicing, ask the customer what the trouble is.
- 2 Check the setup (power supply is 120 V AC, remove the transit bolts....).
- 3 Check with the troubleshooting guide.
- 4 Plan your service method by referring to the disassembly instructions.
- 5 Service the unit.
- 6 After servicing, operate the appliance to see whether it functions correctly.

## ■ STANDARD INSTALLATION

The appliance should be installed as follows:

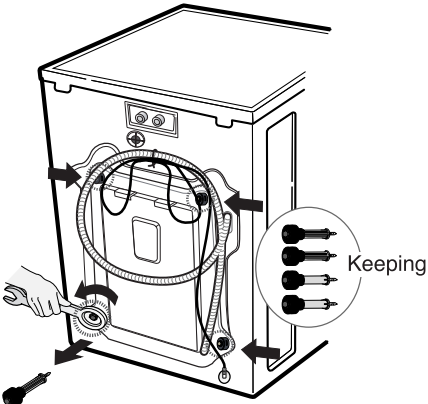
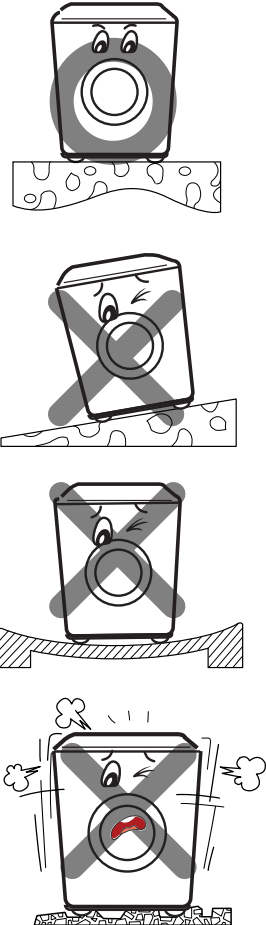
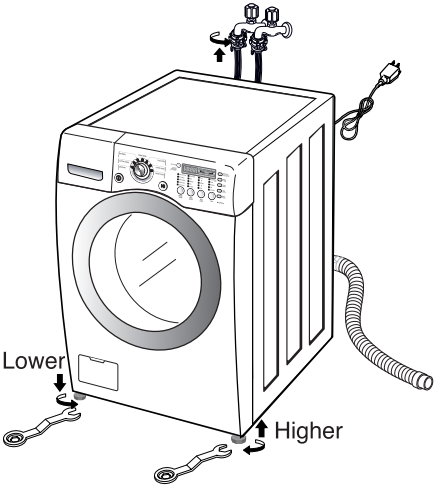
REMOVE THE SHIPPING BOLTS	INSTALL THE APPLIANCE ON A FLAT AND FIRM SURFACE	ADJUST THE LEVELING
<ul style="list-style-type: none"> <li>• Remove the 4 shipping bolts with the supplied wrench.</li> <li>※ Do first lower side to remove easily.</li> <li>• Keep the shipping bolts and spanner for future use.</li> <li>• Insert the 4 caps (provided) into the hole.</li> </ul> 		<ul style="list-style-type: none"> <li>• Turn the leveling feet to adjust the appliance.</li> </ul>  <ul style="list-style-type: none"> <li>• Turn clockwise to raise; counterclockwise to lower.</li> </ul>

## ■ HOW TO CONNECT THE INLET HOSE

- Verify that the rubber washer is inside of the valve connector.
- Tighten the inlet hose securely to prevent leaks.

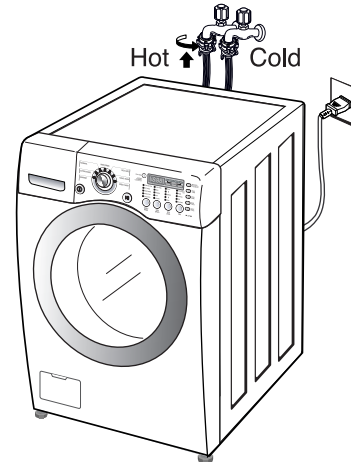

## ■ CONNECT THE DRAIN HOSE

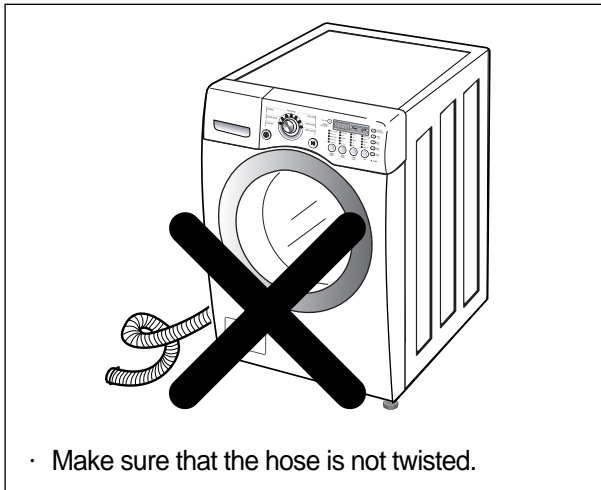

- Make sure that the hose is not twisted.

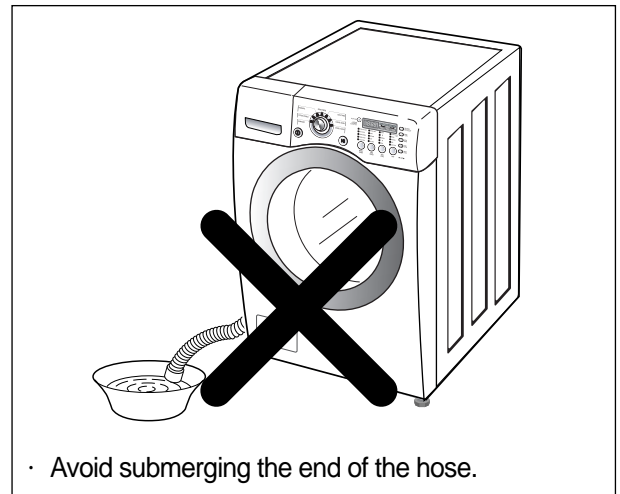

- Avoid submerging the end of the hose.

※ The end of the drain hose should be placed less than 96" from the floor.

## ■ CONNECT POWER PLUG

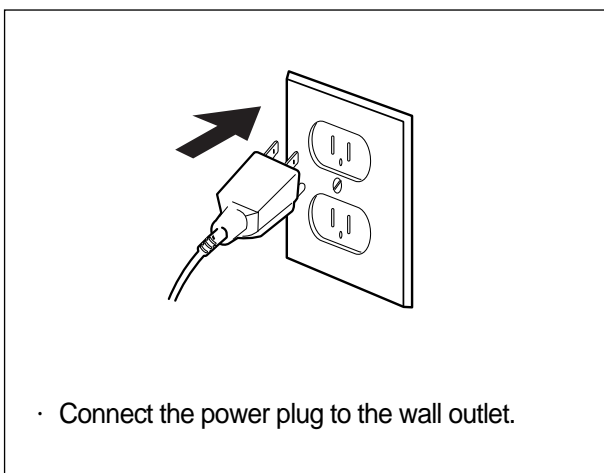

- Connect the power plug to the wall outlet.

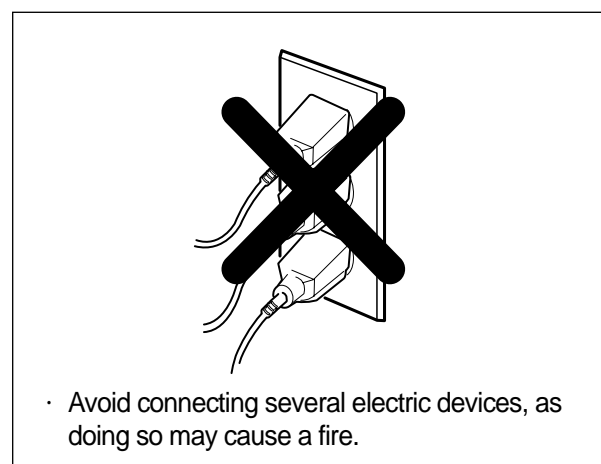

- Avoid connecting several electric devices, as doing so may cause a fire.

## 7 TEST OPERATION

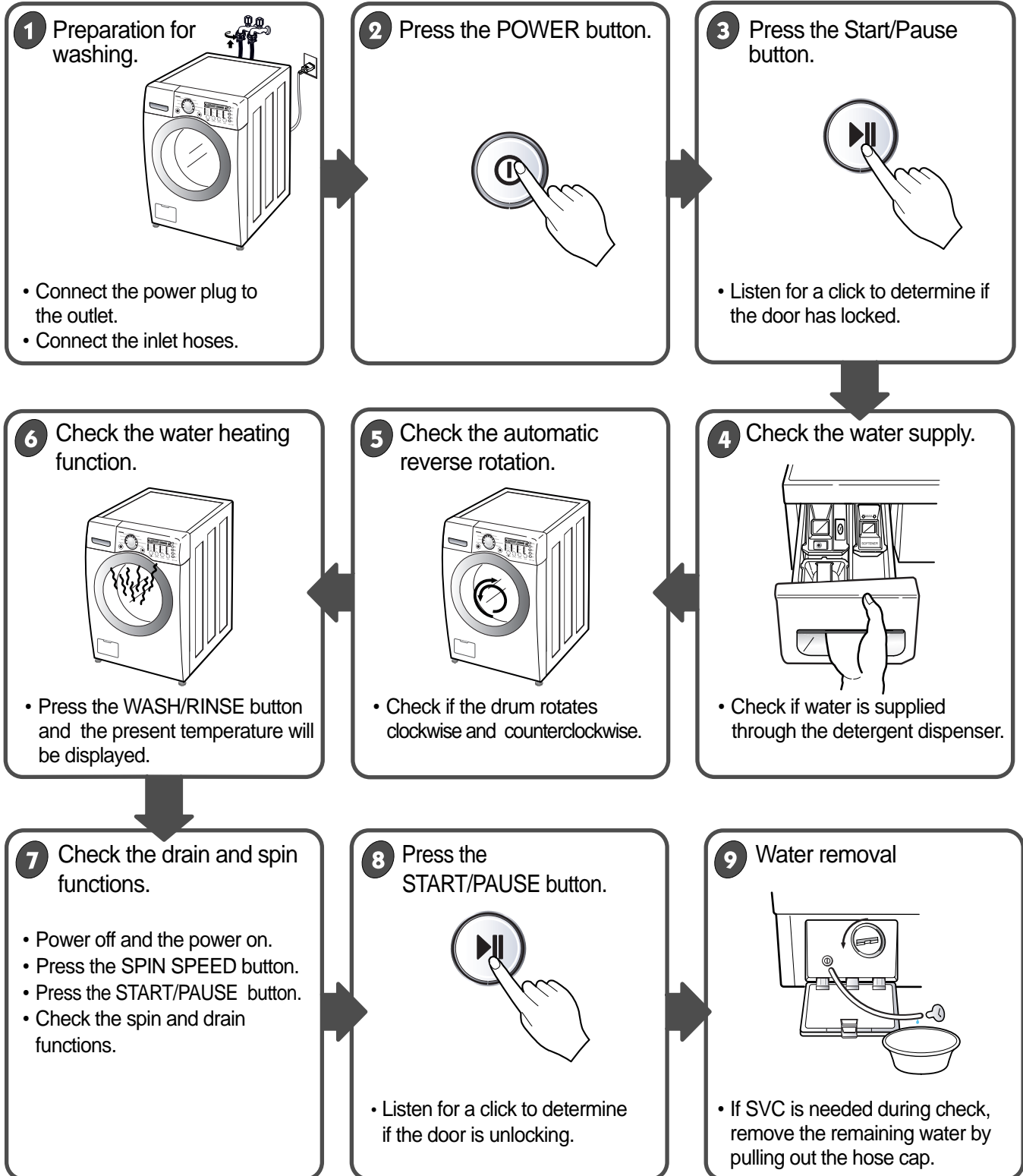

# 5. OPERATION

## ■ WM2544H\*



# 5. OPERATION

## Delay Wash, CUSTOM PROGRAM

- Delay Wash allows the start of any cycle to be delayed for 1~19 hours.
- CUSTOM PROGRAM allows you to store a customized wash cycle for future use.

## EST. TIME REMAINING

- This display shows:
  - a) the estimated time remaining in the cycle when operation.
  - b) an error code when an error has been detected.

## DOOR LOCKED lamp

- Light whenever the door of the washer is locked.
- The door can be unlocked by pressing the **Start/Pause** button 

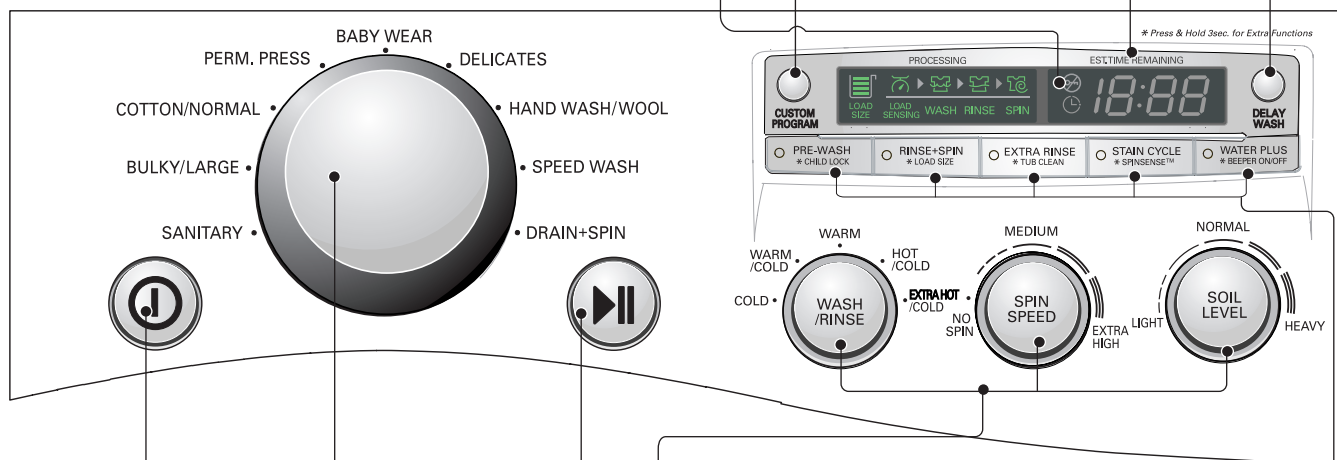

## POWER button

- Use this button to turn power **On/Off**.

## START/PAUSE button

- Use this button to **start/stop** the washer.

## OPTION button

- **Prewash:** Use this option for loads that need pretreatment. It adds 16 minutes prewash and drain.
- **Rinse + Spin:** Use this option to rinse and then spin.
- **EXTRA RINSE:** Select this option to rinse and spin a load separately from a regular cycle.
- **Stain Cycle:** Add time to the wash and rinse for better stain removal. Automatically provide a rinse.
- **WATER PLUS:** Select this option to add extra water to the wash and rinse cycles for superior results, especially with large or bulky items.

## CYCLE SELECTOR

- Rotate the cycle selector knob to select the cycle designed for different types of fabric and soil level.

## Wash, Rinse temp., Spin speed, Soil Level

- Select a water temperature based on the type of load you are washing.
- To change the spin speed, press the Spin Speed button repeatedly to cycle through available options.
- To change the soil level, press the Soil Level button repeatedly until the desired setting is on.

# 6. WIRING DIAGRAM/PROGRAM CHART

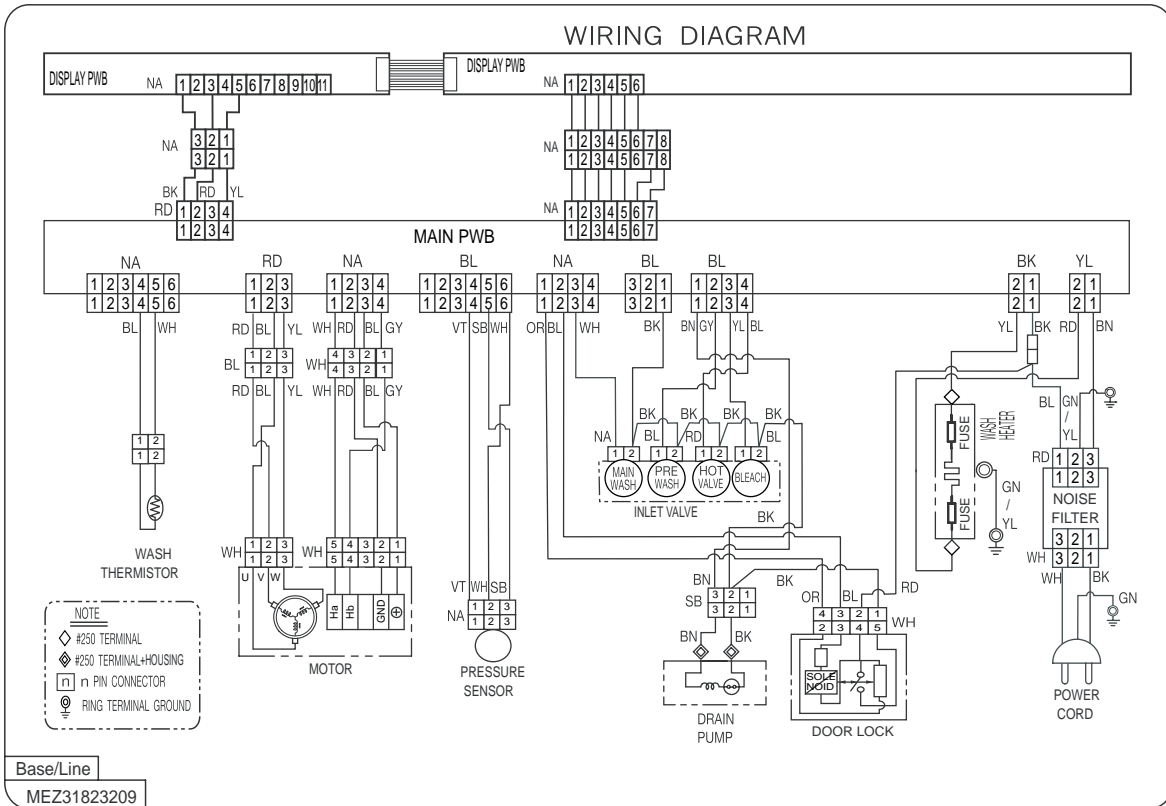

## PROGRAM CHART

\* Water Supply: W-S \* Intermittent Spin: I-S \* Disentangle: D-T

COURSE CYCLE STEP TIME (SEC)	Wash				Rinse												Spin			A U T O F F	**Approx. Working Time (Minutes)												
	Pre		Main		Normal			Extra or Stain			Extra & Stain			D T	E N D																		
	W S	W S	W S	W S	1	2	3	3	3	3	3	3																					
	Wash	Drain	Wash	Cool-down	Wash	Rinse	Drain	Drain	I S	W S	Rinse	Drain	I S	W S	Rinse	Drain	I S	W S	Rinse														
1	60	*	60	300	60	*	60	60	60	60	360	60	240	60	360	60	240	60	300	60	240	60	300	60	240	60	360 ~ 660	60 ~ 180	20	20			
Sanitary		8				60																										98	
Cotton/Normal		8				13																										51	
Bulky/Large		8				20																										57	
Perm Press		8				25																										55	
Delicates		8				18																										40	
Baby Wear						70																										111	
Hand Wash/Wool						14																										40	
Speed Wash						8																										20	
Drain+Spin																																13	
Wash + Rinse		8																															
Rinse + Spin																																	18

■ Basic Cycle  
 ▨ Optional Cycle  
 Pre-Setting Time : Water Supply - 60 sec.  
 Drain - 60 sec.

\* Wash time is in minutes.  
 \*\* The total working time will vary with the load size, water temperature and ambient temperature.

# 7. TROUBLESHOOTING

## 7-1. BEFORE PERFORMING SERVICE

- Be careful of electric shock when disconnecting parts while troubleshooting.
- The voltage of each terminal is 120 V AC and DC when the unit is plugged in.

## 7-2. QC TEST MODE.

The washer must be empty and the controls must be in the off state.

1. Press the WASH/RINSE and SPIN SPEED buttons simultaneously.
2. Press the Power (⏻) button, while the above condition. Then buzzer will sound twice.
3. Press the Start/Pause (⏸) button repeatedly to cycle through the test modes.

Number of times the Start/Pause button is pressed	Check Point	Display Status
None	Turns on all lamps and locks the door.	17:00 → 12:00 → 11:00
1 time	Tumble clockwise.	rpm (42~50)
2 times	Low speed Spin.	rpm (55~65)
3 times	High speed Spin.	rpm (105~115)
4 times	Inlet valve for prewash turns on.	Water level frequency (225~265)
5 times	Inlet valve for main wash turns on.	Water level frequency (225~265)
6 times	Inlet valve for hot water turns on.	Water level frequency (225~265)
7 times	Inlet valve for bleach turns on.	Water level frequency(225~265)
8 times	Tumble counterclockwise.	rpm (42~50)
9 times	Water Temperature (Thermistor)	Water Temperature [°C]
10 times	Drain pump turns on.	Water level frequency (225~265)
11 times	Off	

## 7-3. HOW TO CHECK THE WATER LEVEL FREQUENCY



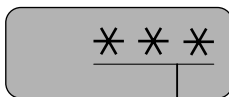



- \* Press the **CUSTOM PROGRAM** and **PRE-WASH** buttons simultaneously.





- The digits indicate the water level frequency.  
A display indicating 41 means a water level frequency of 24.1 kHz.

## 7-4. ERROR DISPLAY

- If you press the START/PAUSE button when an error is displayed, any error except 『PE』 will disappear and the machine will go into the pause status.
- In case of 『PE』, 『UE』, 『DE』 if the error is not resolved within 20 sec., or the in case of other errors, if the error is not resolved within 4 min., power will be turned off automatically and the error code will blink. But in the case of 『FE』, power will not be turned off.







	ERROR	SYMPTOM	CAUSE
1	WATER INLET ERROR		<ul style="list-style-type: none"> <li>• Correct water level (246) is not reached within 8 minutes after water is supplied or it does not reach the preset water level within 25 minutes.</li> </ul>
2	IMBALANCE ERROR		<ul style="list-style-type: none"> <li>• The load is too small.</li> <li>• The appliance is tilted.</li> <li>• Laundry is gathered to one side.</li> <li>• Non distributable things are put into the drum.</li> </ul>
3	DRAIN ERROR		<ul style="list-style-type: none"> <li>• Not fully drained within 10 minutes.</li> </ul>
4	OVER FLOW ERROR		<ul style="list-style-type: none"> <li>• Water is overflowing (water level frequency is over 213).</li> <li>※ If 『FE』 is displayed, the drain pump will operate to drain the water automatically.</li> </ul>
5	PRESSURE SENSOR ERROR		<ul style="list-style-type: none"> <li>• The SENSOR SWITCH ASSEMBLY is out of order.</li> </ul>
6	DOOR OPEN ERROR		<ul style="list-style-type: none"> <li>• Door not all the way closed.</li> <li>• Loose electrical connections at Door switch and PWB Assembly.</li> <li>• The DOOR SWITCH ASSEMBLY is out of order.</li> </ul>
7	HEATING ERROR		<ul style="list-style-type: none"> <li>• The THERMISTOR is out order.</li> </ul>



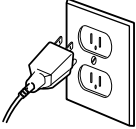
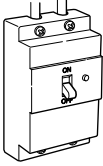

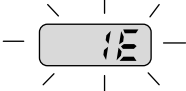

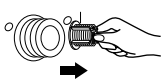

	ERROR	SYMPTOM	CAUSE
8	LOCKED MOTOR ERROR		<ul style="list-style-type: none"> <li>• The connector (3-pin, male, white) in the MOTOR HARNESS is not connected to the connector (3-pin, female, white) of STATOR ASSEMBLY.</li> <li>• The electric contact between the connectors (3-pin, male, white) in the MOTOR HARNESS and 4-pin, female, white connector in the MAIN PWB ASSEMBLY is bad or unstable.</li> <li>• The MOTOR HARNESS between the STATOR ASSEMBLY and MAIN PWB ASSEMBLY is cut (open circuited).</li> <li>• The hall sensor is out of order/defective.</li> </ul>
9	EEPROM ERROR		<ul style="list-style-type: none"> <li>• EEPROM is out of order.            ※ Displayed only when the START/PAUSE button is first pressed in the QC Test Mode.</li> </ul>
10	POWER FAILURE		<ul style="list-style-type: none"> <li>• The washer experienced a power failure.</li> </ul>

# 8. ERROR DIAGNOSIS AND CHECK LIST

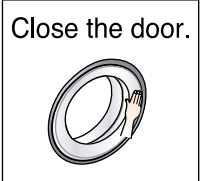
## 8-1. DIAGNOSIS AND SOLUTION FOR ABNORMAL OPERATION

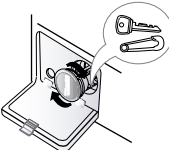
SYMPTOM	GUIDE FOR SERVICE CALL	
<p>No power</p>	<p>Is the power plug connected firmly to 120 V AC outlet?</p> <p style="text-align: center;"><b>YES</b></p> <p>Power failure? or Breaker opened? Is the outlet controlled by a switch?</p> <p style="text-align: center;"><b>NO</b></p> <p style="text-align: center;">Visit to service.</p>	 
<p>Water inlet trouble</p> 	<p>Is  displayed?</p> <p style="text-align: center;"><b>YES</b></p> <p>Is the tap opened?</p> <p style="text-align: center;"><b>YES</b></p> <p>Is the tap frozen?</p> <p style="text-align: center;"><b>NO</b></p> <p>Is the water supply shut-off?</p> <p style="text-align: center;"><b>NO</b></p> <p>Is filter in the inlet valve clogged with foreign material?</p> <p style="text-align: center;"><b>NO</b></p> <p style="text-align: center;">Visit to service.</p>	    <p>Clean the filter of inlet valve</p> 

SYMPTOM	GUIDE FOR SERVICE CALL
<p>Door error</p> 	<p>Started with door opened? <b>YES</b> → </p> <p><b>NO</b> ↓</p> <p>Was the load too large? <b>YES</b> → Avoid overloading.</p> <p><b>NO</b> ↓</p> <p>Clicking sound is heard once or twice, when the START/PAUSE button is pressed to start the cycle?</p> <p><b>NO</b> ↓</p> <p>Visit to service.</p> <p>Check if the door switch is OK.</p> <p>Close the door. </p>
<p>Drain trouble</p> 	<p>Is  displayed? <b>YES</b> ↓</p> <p>Is the drain pump filter clogged with foreign material such as pins, coins, etc? <b>YES</b> → Clean up the filter. </p> <p><b>NO</b> ↓</p> <p>Is the drain hose frozen, kinked, or crushed? <b>NO</b> ↓</p> <p>Visit to service. </p>

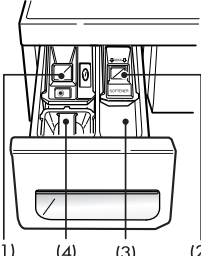
SYMPTOM	GUIDE FOR SERVICE CALL
<p>Suds overflow from the appliance. (In this condition, wash and spin do not operate normally)</p>	<div style="display: flex; justify-content: space-between; align-items: center;"> <div style="width: 60%;"> <p>Is a HE (High Efficiency) detergent used?</p> <p style="text-align: center;">↓ YES ↓</p> <p>Is the proper amount of detergent used as recommended?</p> <p style="text-align: center;">↓ YES ↓</p> <p>Recommend to reduce the amount of detergent.</p> <ul style="list-style-type: none"> <li>* This appliance has an automatic suds sensing function which prevents overflow.</li> <li>* When excessive suds are sensed, the suds removing implementations such as drain, water input, pause will operate, without rotating the drum.</li> </ul> </div> <div style="width: 35%; text-align: center;">  </div> </div>
<p>Liquid laundry products do not flow in.</p>	<div style="display: flex; justify-content: space-between; align-items: center;"> <div style="width: 60%;"> <p>Is liquid laundry product put in the correct compartment of the dispenser?</p> <p style="text-align: center;">↓ YES ↓</p> <p>Is the cap clogged?</p> <p style="text-align: center;">↓ YES ↓</p> <p>Explain proper use of liquid laundry products.</p> <p><b>Clean the compartment.</b></p> </div> <div style="width: 35%; text-align: center;">  <p>(1) (4) (3) (2)</p> <p>(1) Liquid chlorine Bleach Compartment (2) Liquid fabric Softener Compartment (3) Prewash Compartment (4) Main Wash Compartment</p> </div> </div>
<div style="display: flex; flex-wrap: wrap; justify-content: center; gap: 10px;"> <div style="border: 1px solid black; padding: 2px 5px; margin: 2px;">FE</div> <div style="border: 1px solid black; padding: 2px 5px; margin: 2px;">FE</div> <div style="border: 1px solid black; padding: 2px 5px; margin: 2px;">LE</div> <div style="border: 1px solid black; padding: 2px 5px; margin: 2px;">LE</div> </div>	<p style="text-align: center; border: 1px solid black; border-radius: 15px; padding: 10px; width: fit-content; margin: 0 auto;">Visit to service.</p>

## 8-2. FAULT DIAGNOSIS AND TROUBLESHOOTING

### CAUTION

1. Be careful of electric shock if disconnecting parts while troubleshooting.
2. First of all, check the connection of each electrical terminal with the wiring diagram.
3. If you replace the MAIN PWB ASSEMBLY, reinsert the connectors correctly.

### NO POWER

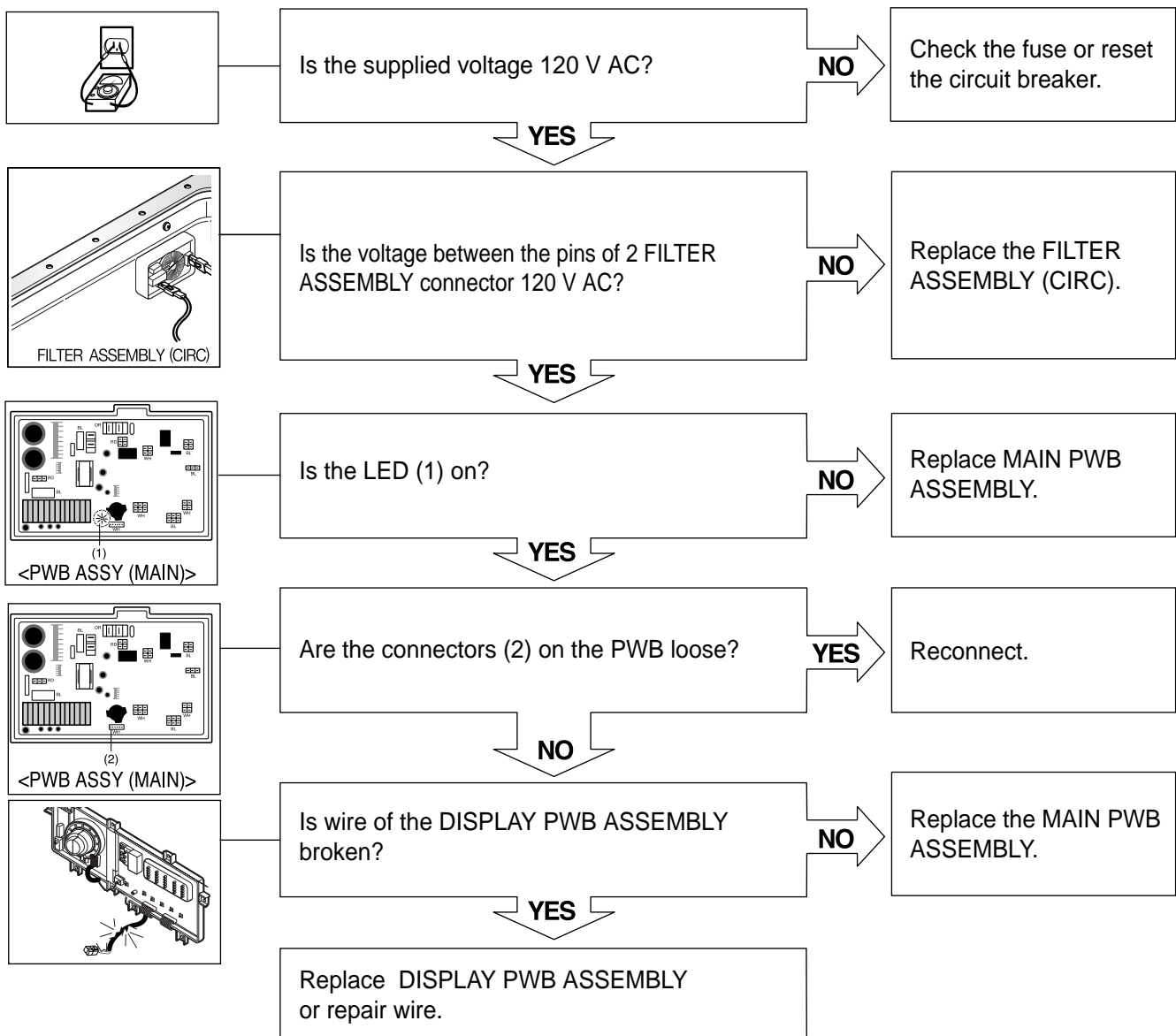

## VIBRATION & NOISE IN SPIN

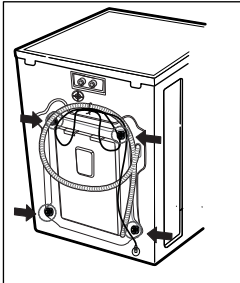

Have all the transit bolts and base packing been removed?

**NO**

Remove the transit bolts and Base packing.

**YES**

Is the washer installed on a solidly constructed floor?

**NO**

Move the washer or reinforce the floor.

**YES**

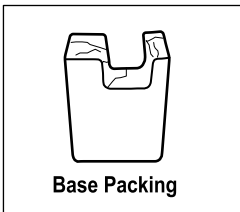

Check if the washer is perfectly level as follows:

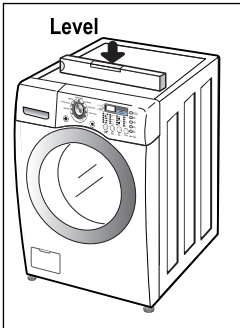

Check the leveling of the washer with a Level and check that the washer is stable.

Put an unbalance part (rubber) inside of drum and start QC test mode and run in high spin (Refer to section 7-2).  
When the machine is spinning in high speed, verify that it is stable.

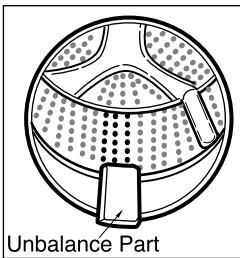

If you do not have the unbalance part, put 4.5 to 6.5 lbs (2 to 3 kg) of clothing. Once loaded, press power, Rinse+Spin and the start/pause button in sequence.  
When the machine is spinning in high speed, verify that it is stable.

**YES**

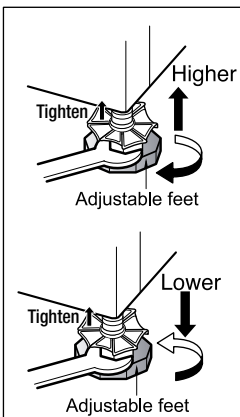

If it is not stable, adjust feet accordingly. After the washer is level, tighten the lock nuts up against of the base of the washer. All lock nuts must be tightened.

## NO WATER SUPPLY

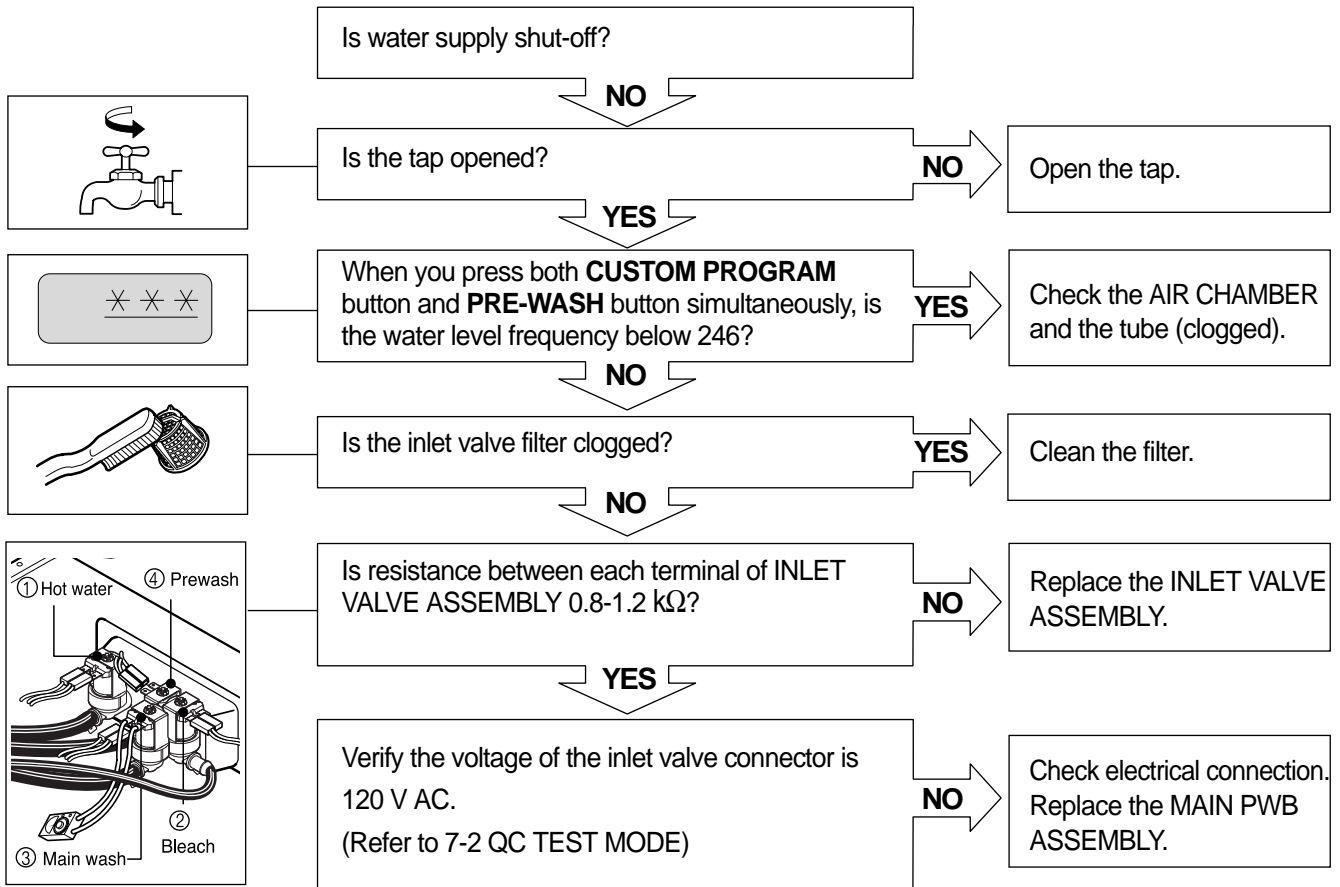

## DETERGENT DOES NOT FLOW IN

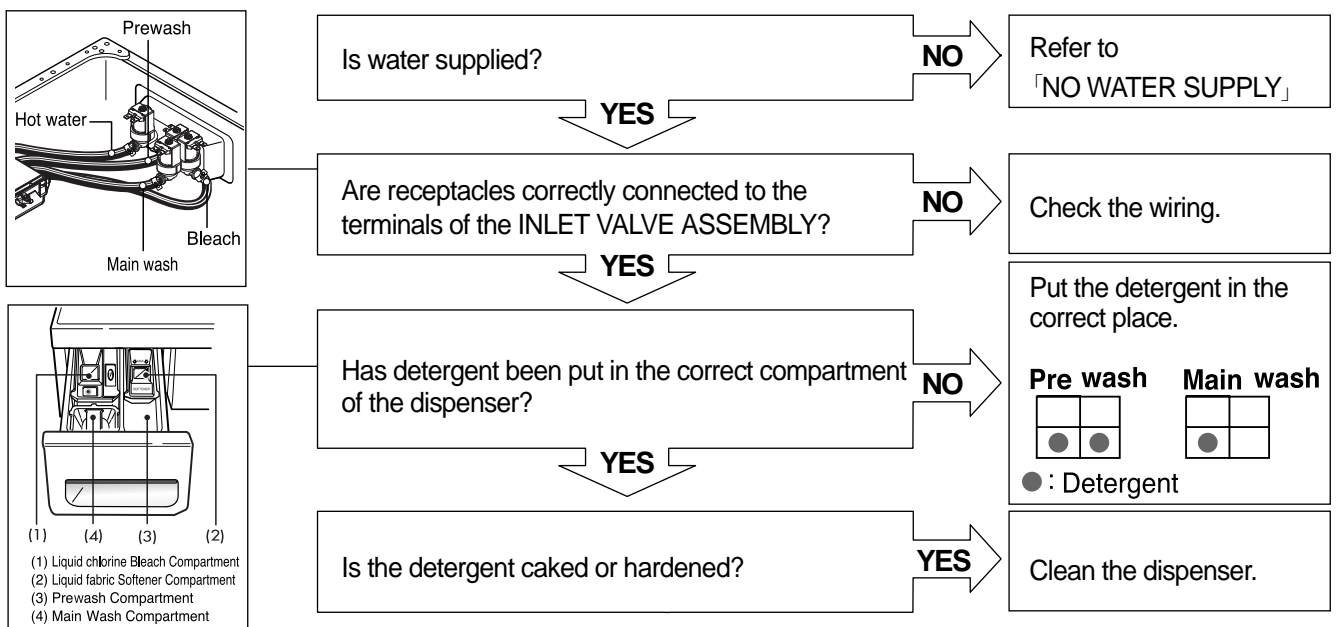

## LIQUID DETERGENT/SOFTENER/BLEACH DOES NOT FLOW IN

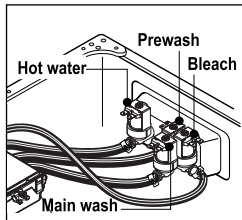

Is water supplied?

**NO**

Refer to  
「NO WATER SUPPLY」

**YES**

Are the plugs correctly connected to the terminals of the INLET VALVE ASSEMBLY?

**NO**

Check the wiring on the dispenser.

**YES**

Is liquid detergent/softener/bleach put in the correct compartment of the drawer?

**NO**

Put it in the correct compartment.

**YES**

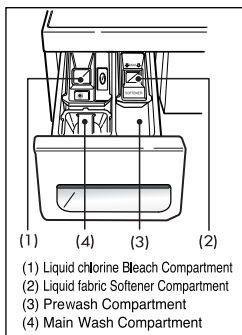

Is the liquid detergent/softener/bleach cap clogged?

**YES**

Clean the Cap and Container.

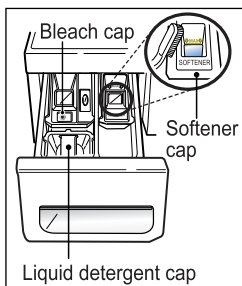

## ABNORMAL SOUND

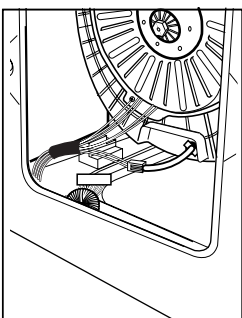

Is the motor bolt loosened?

**YES**

Secure the bolt.

**NO**

Is there friction noise coming from the motor?

**YES**

Replace the STATOR ASSEMBLY or ROTOR ASSEMBLY.



## HEATING WITHOUT WATER

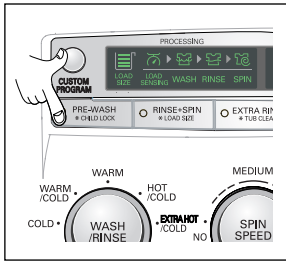

When pressing **CUSTOM PROGRAM** and **PRE-WASH** at the same time after draining, is the water level frequency 255?

When pressing **WASH/RINSE** and **DELAY WASH** buttons at the same time while washing, is the water level frequency between 230 - 243 ?

**NO**

Replace the **SENSOR SWITCH ASSEMBLY**.

**YES**

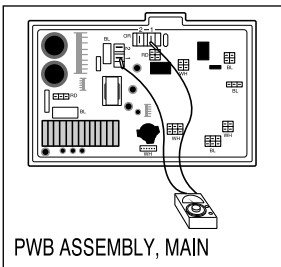

Check the voltage between two pins while pressing the **POWER** button. Is the voltage 120 V AC?

**YES**

Replace the **MAIN PWB ASSEMBLY**.

## DRAIN MALFUNCTION

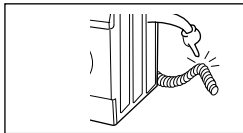

Is the drain hose twisted or frozen?

**YES**

Repair the **DRAIN HOSE ASSEMBLY**.

**NO**

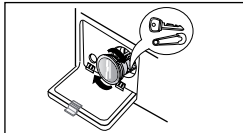

Is the impeller of the drain pump clogged?

**YES**

Remove foreign material.

**NO**

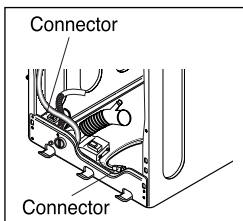

Is the connector disconnected, disassembled?

**YES**

Reconnect or repair the connector

**NO**

Is the coil of the drain pump too high or low?  
(resistance of the coil is 10-20  $\Omega$ )

**YES**

Replace the **DRAIN PUMP ASSEMBLY**.

**NO**

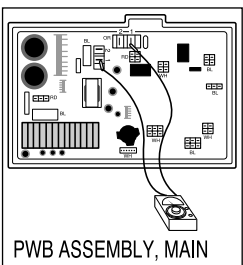

When checking voltage between connectors during spin, is the voltage 120 V AC as in the figure?

**NO**

Replace the **MAIN PWB ASSEMBLY**.

## WASH HEATER TROUBLE

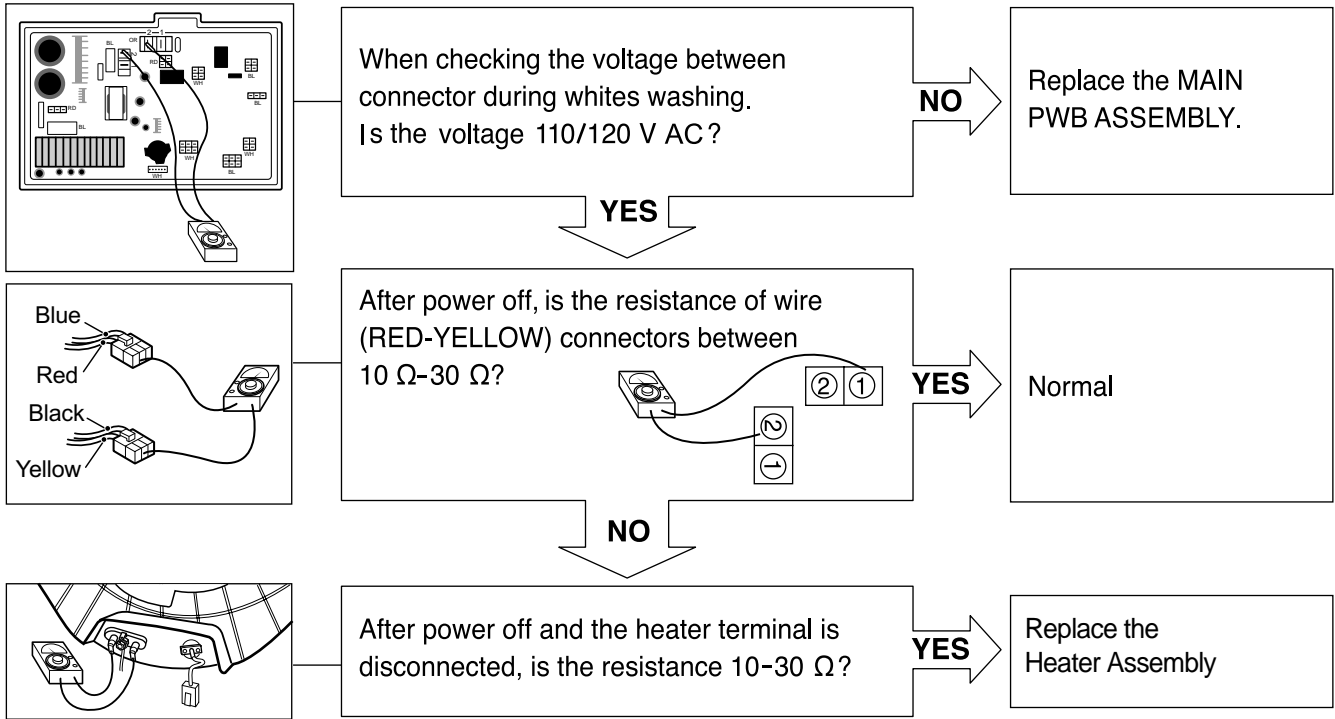

## HEATING CONTINUOUSLY ABOVE THE SETTING WATER TEMPERATURE

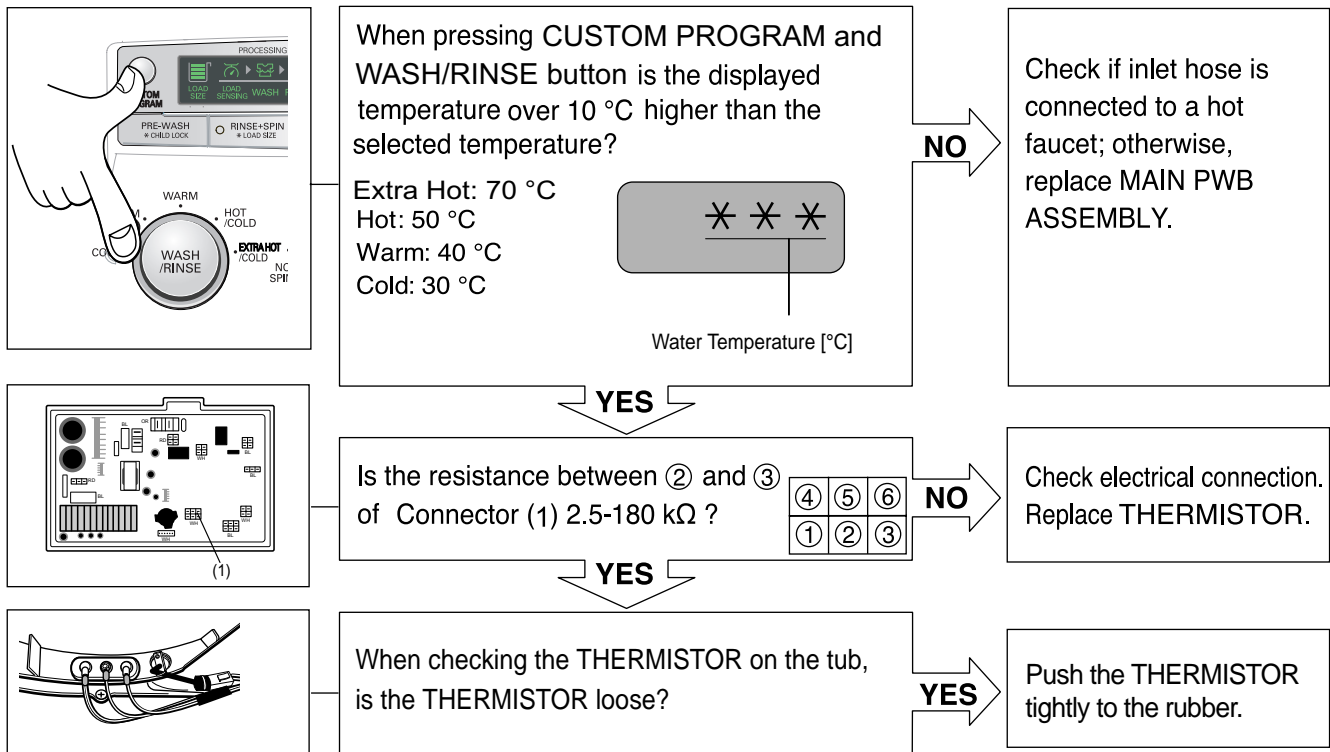

## SPIN TROUBLE

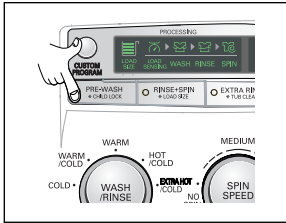

Check during spin if the frequency of the water level is 248 or more.

**NO** →

Check the SENSOR SWITCH ASSEMBLY or HOSE (Pressure). If the problem is on the SENSOR SWITCH ASSEMBLY or the HOSE, replace the SENSOR SWITCH ASSEMBLY or the HOSE.

**YES** ↓

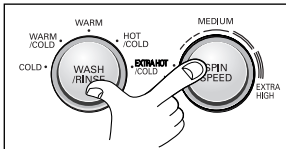

Press the **START/PAUSE** button 2 times in QC Test mode, is the drum spinning at low speed?

**YES** →

Normal

**NO** ↓

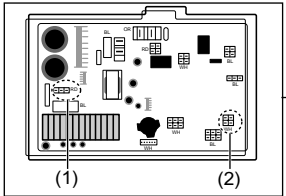

Is it disconnected, or disassembled?  
[Red: 3pin (1), NA: 4pin (2)]

**YES** →

Correct the connection.

**NO** ↓

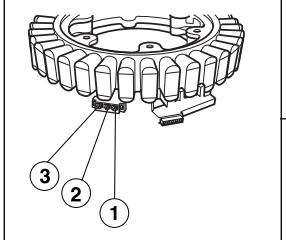

Check the motor connector, Is the resistance of the terminal the same as the figure?

**MOTOR TERMINAL**



Resistance of terminal:

①-②/②-③/③-①: About 5 Ω – 15 Ω

**NO** →

Replace the STATOR ASSEMBLY

**YES** ↓

Replace the MAIN PWB ASSEMBLY

## E ERROR

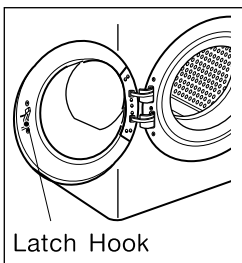

Does the spring of Latch Hook actuate?

**NO** →

Replace Door Assembly.

**YES** ↓

Is there clicking sound once or twice when the **START/PAUSE** button is pressed to start the cycle?

**NO** →

Check the DOOR SWITCH ASSEMBLY Connector and MAIN PWB ASSEMBLY (Red 3 pin, Yellow 4 pin and white 3 pin connector (1)).

**YES** ↓

Is DOOR SWITCH ASSEMBLY broken?

**YES** →

Replace the DOOR SWITCH ASSEMBLY.

# 9. DISASSEMBLY INSTRUCTIONS

\* Be sure to unplug the machine out of the outlet before disassembling and repairing the parts.

## CONTROL PANEL ASSEMBLY

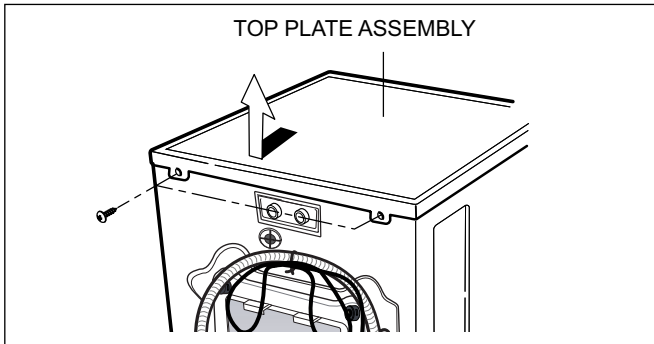

- ① Unscrew 2 screws on the back of the top plate.
- ② Pull the top plate backward and upward as shown.

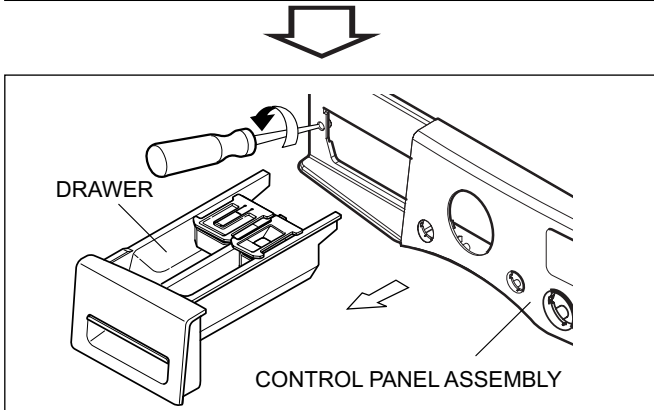

- ③ Disconnect the Display PWB Assembly connector from Trans cable.
- ④ Pull out the drawer and unscrew 2 screws.

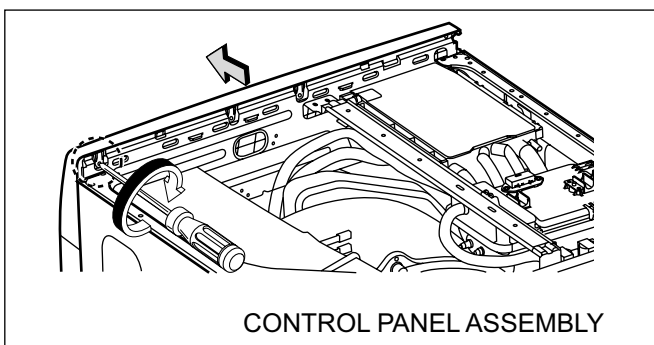

- ⑤ Taking out 1 screw.
- ⑥ Lift the side the Control Panel Assembly and pull it out

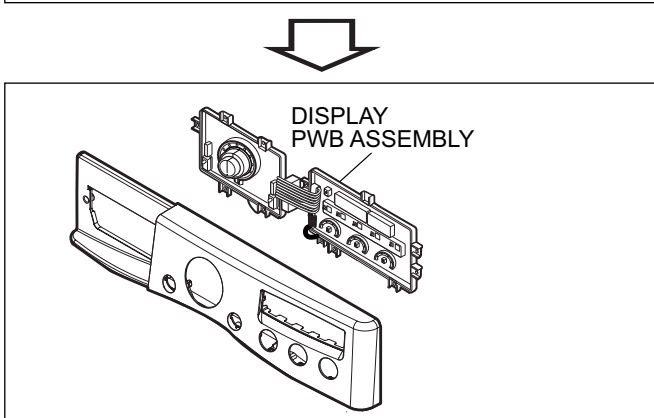

- ⑦ Unscrew the 8 screws from the Control Panel Assembly.
- ⑧ Disassemble the Display PWB Assembly.

## MAIN PWB ASSEMBLY

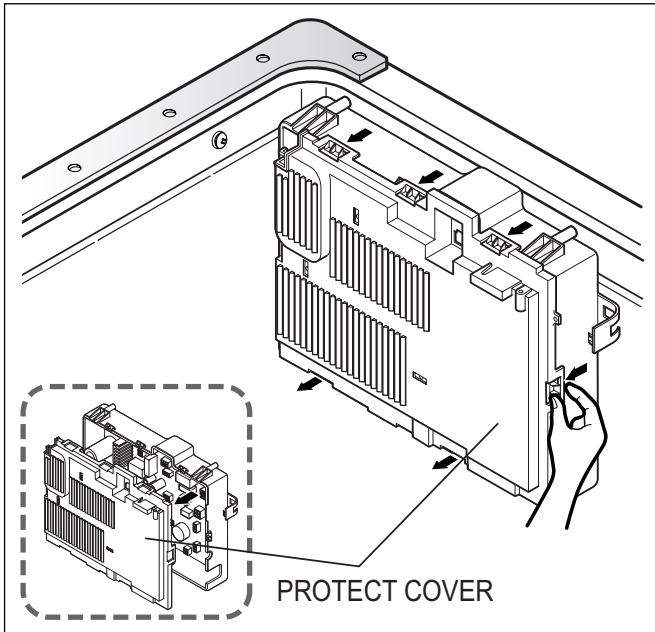

- ① Disconnect the SENSOR SWITCH ASSEMBLY.
- ② Remove the Protect Cover.

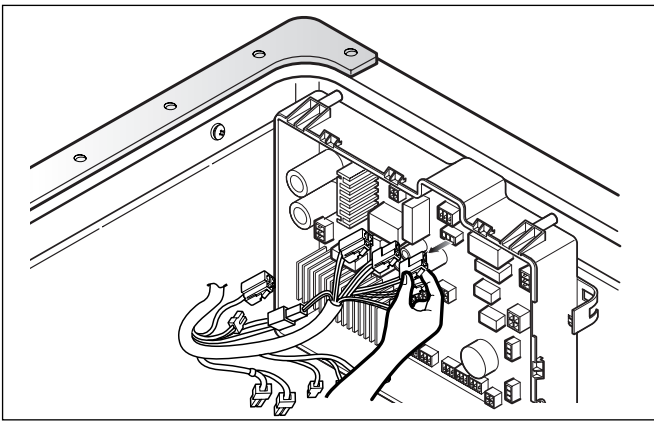

- ③ Disconnect the connectors.

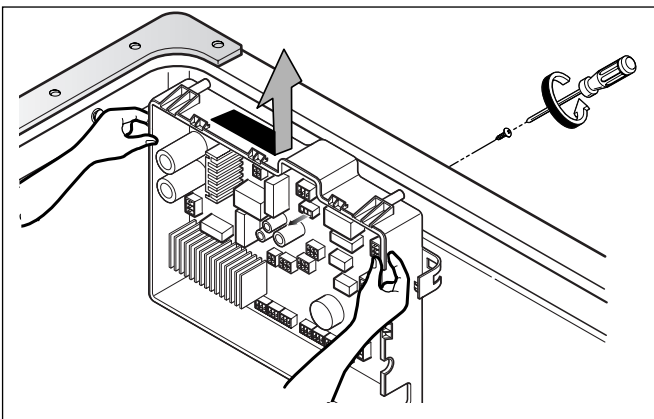

- ④ Unscrew 1 screw on the back.
- ⑤ Disassemble the Main PWB.

## DISPENSER ASSEMBLY

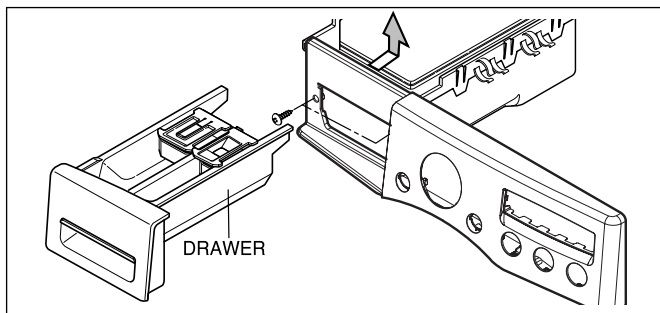

- ① Disassemble the top plate assembly.
- ② Pull out the drawer.
- ③ Push out the DISPENSER ASSEMBLY after unscrew 2 screws.

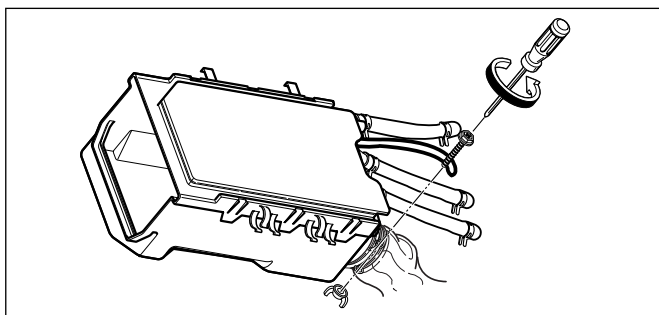

- ④ Unscrew the nut at the lower part of the dispenser.

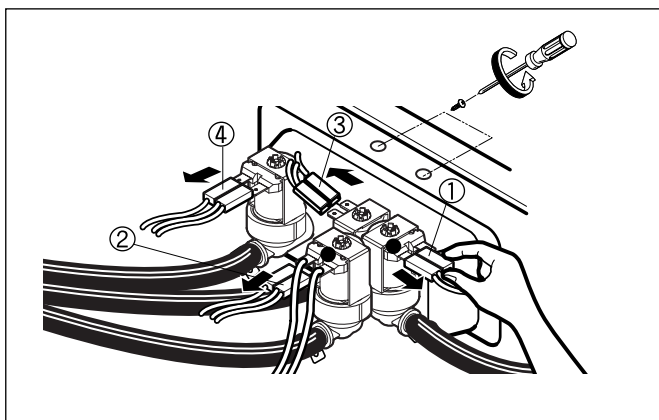

- ⑤ Disassemble the 4 connectors from the valves.

### ※ Wire Color

- ① Blue Housing (YL-BK)
- ② White Housing (WH-BK)
- ③ Blue Housing (GY-BK)
- ④ Red Housing (BL-BK)

- ⑥ Unscrew 2 screws from the back of the cabinet.

## NOISE FILTER

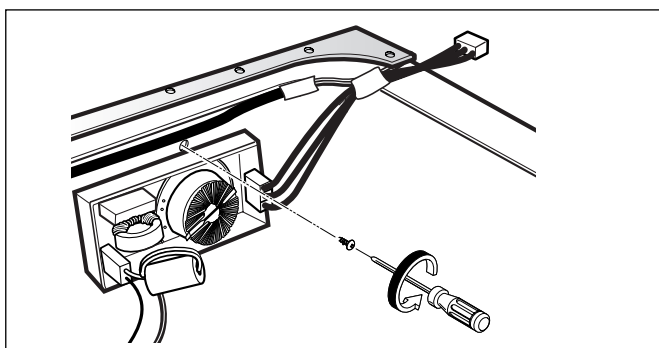

- ① Disassemble two (or three) connectors from the NOISE FILTER.
- ② Unscrew a screw from the TOP BRACKET.

## CABINET COVER

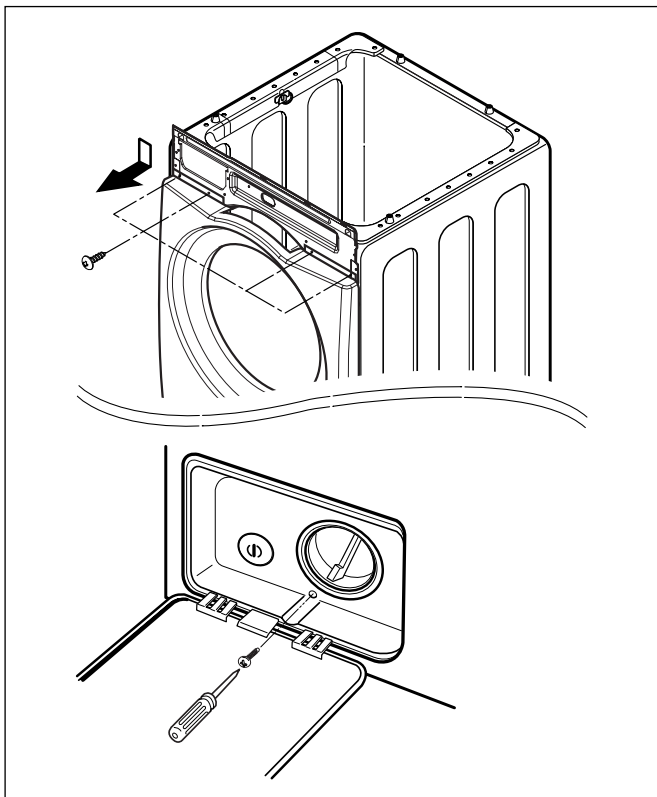

- ① Unscrew the 5 screws from upper of the cabinet cover.
- ② Unscrew the screw from filter cover.

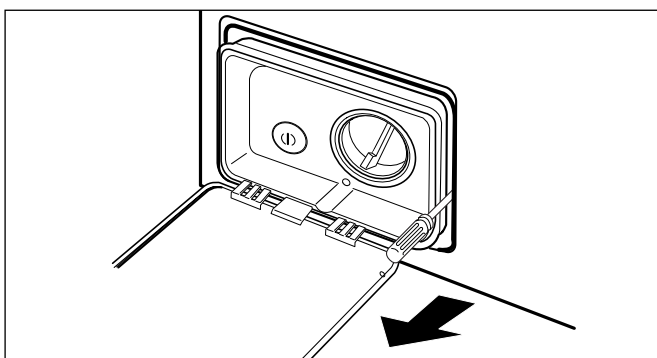

- ③ Put a flat ( - ) screwdriver or putty knife into the both sides of the filter cover, and pull it out.

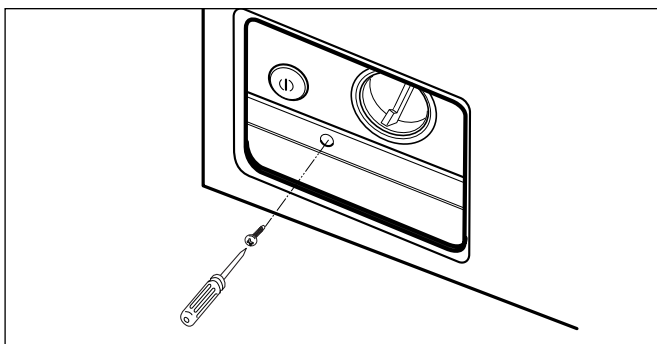

- ④ Unscrew the screw from the lower side of the cabinet cover.

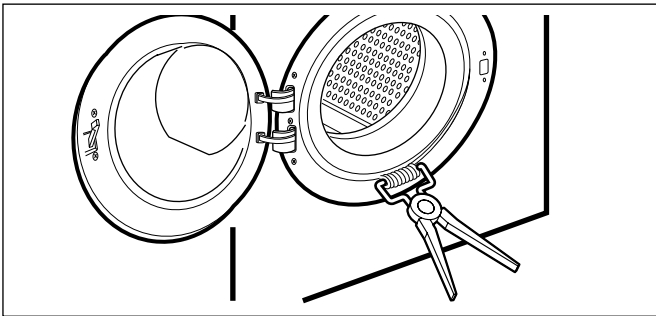

- ⑤ Open the door.
- ⑥ Disassemble the clamp assembly.

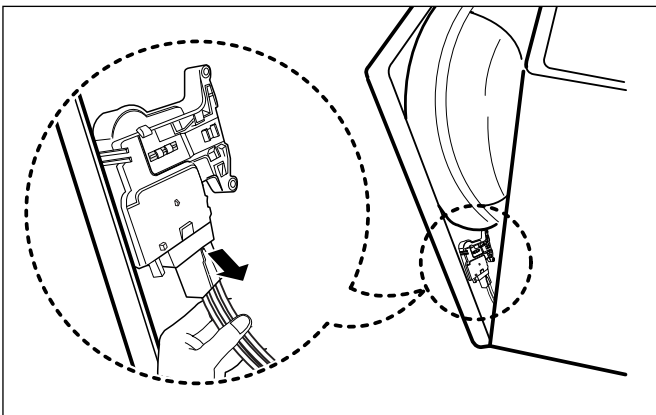

- ⑦ Tilt the cabinet cover.
- ⑧ Disconnect the door switch connector.

※ **NOTE:** When assembling the CABINET COVER, connect the connector.

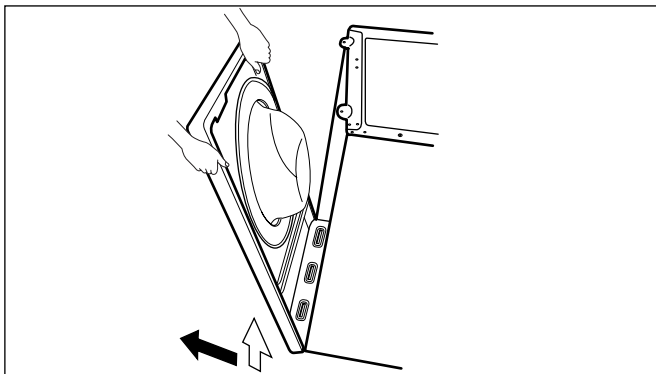

- ⑨ Lift and separate the cabinet cover.

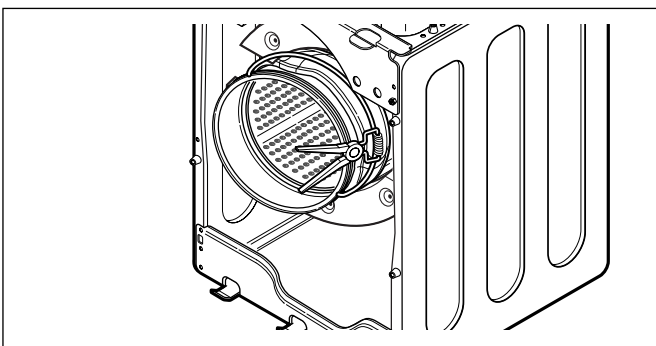

- ⑩ Disassemble the clamp assembly.
- ⑪ Disassemble the Gasket.



## DOOR

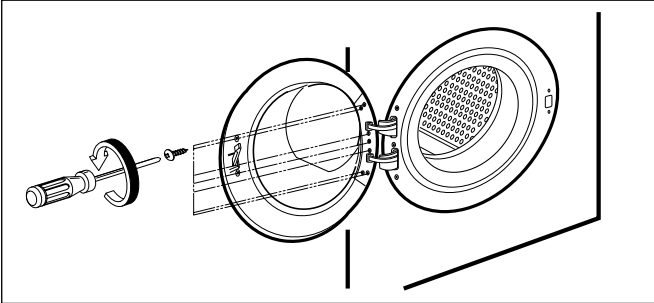

- ① Open the door.
- ② Unscrew the 7 screws from the HINGE COVER.

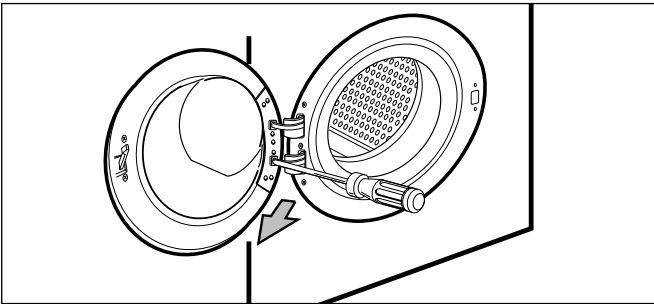

- ③ Put a flat (-) screwdriver into the opening of the hinge, and pull out the hinge cover.

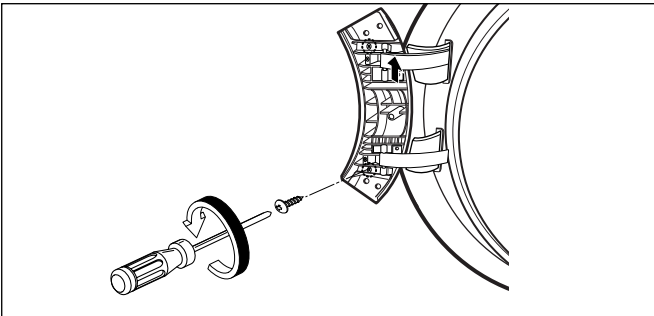

- ④ Unscrew a screw from the lower side of door.
- ⑤ Disassemble the door upward.

※ **Be careful!** The door is heavy.

## DOOR LOCK SWITCH ASSEMBLY

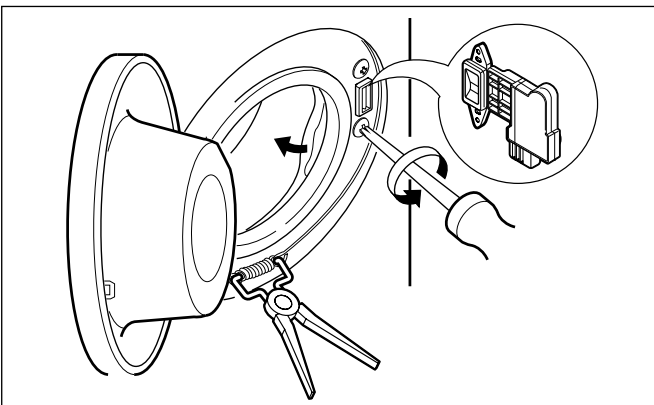

- ① Open the door and disassemble the CLAMP ASSEMBLY.
- ② Unscrew the 2 screws.

### ※ NOTE

- Reconnect the connector after replacing the DOOR SWITCH ASSEMBLY.

## PUMP

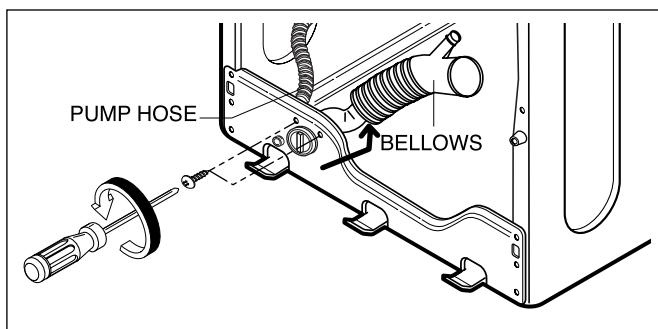

- ① Disassemble the cabinet cover.
- ② Separate the pump hose, and the bellows.
- ③ Disassemble the pump assembly in arrow direction.

## HEATER

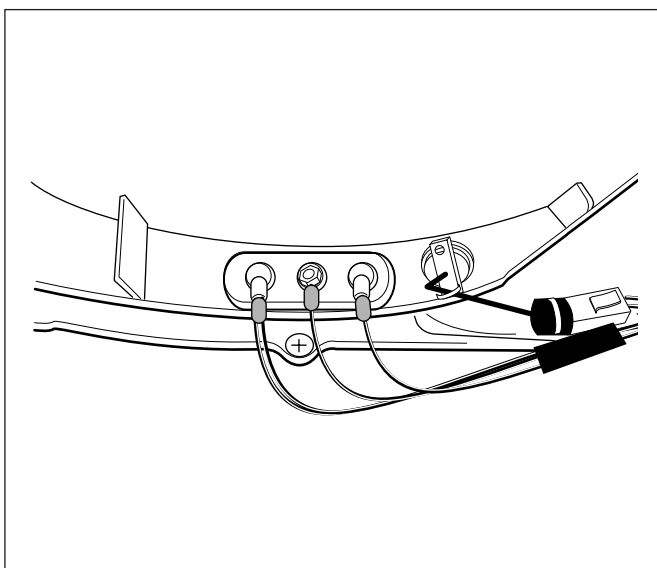

- ① Disassemble the cabinet cover.
- ② Separate 2 connectors from the heater.
- ③ Loosen the nut and pull out the heater.

### ※ CAUTION

- When assembling the heater, insert the heater into the heater clip on the bottom of the tub.
- Tighten the fastening nut so the heater is secure.

## THERMISTOR

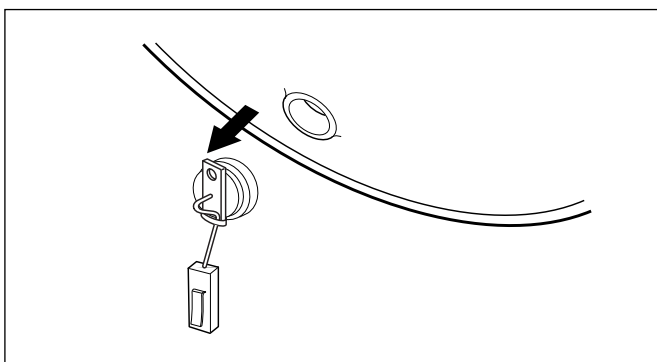

- ① Disassemble the cabinet cover.
- ② Unplug the white connector from the thermistor.
- ③ Pull it out by holding the bracket of the thermistor.

## MOTOR/DAMPER

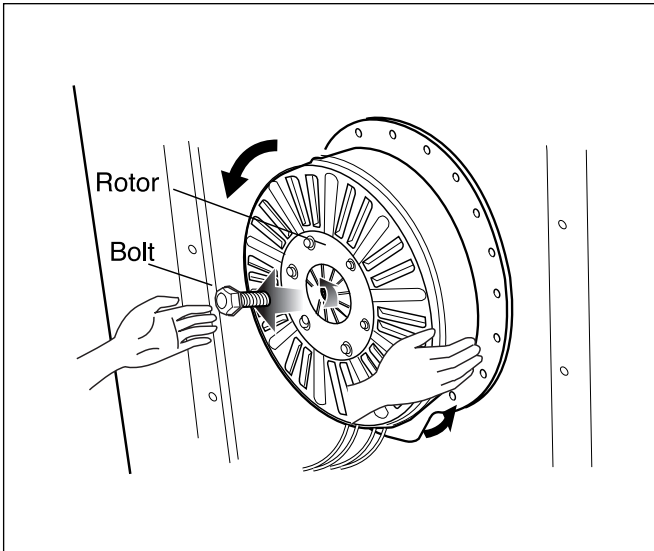

- ① Disassemble the back cover.
- ② Remove the bolt.
- ③ Pull out the Rotor.

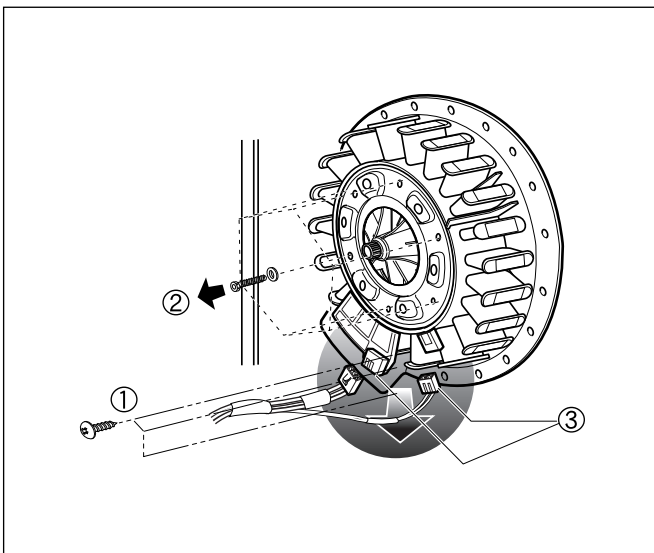

- ① Unscrew the 2 screws from the tub bracket.
- ② Remove the 6 bolts on the stator.
- ③ Unplug the 2 connectors from the stator.

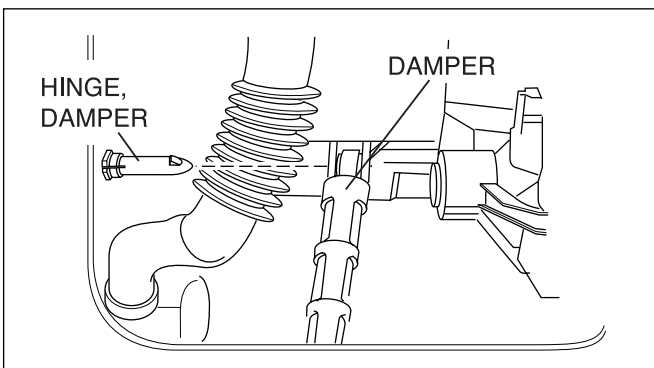

- ① Disassemble the damper hinges from the tub and base.
- ② Separate the dampers.

### ※ NOTE

- Once removed, replace the damper with new one.

# 10. EXPLODED VIEW

## 10-1. CABINET & CONTROL PANEL ASSEMBLY

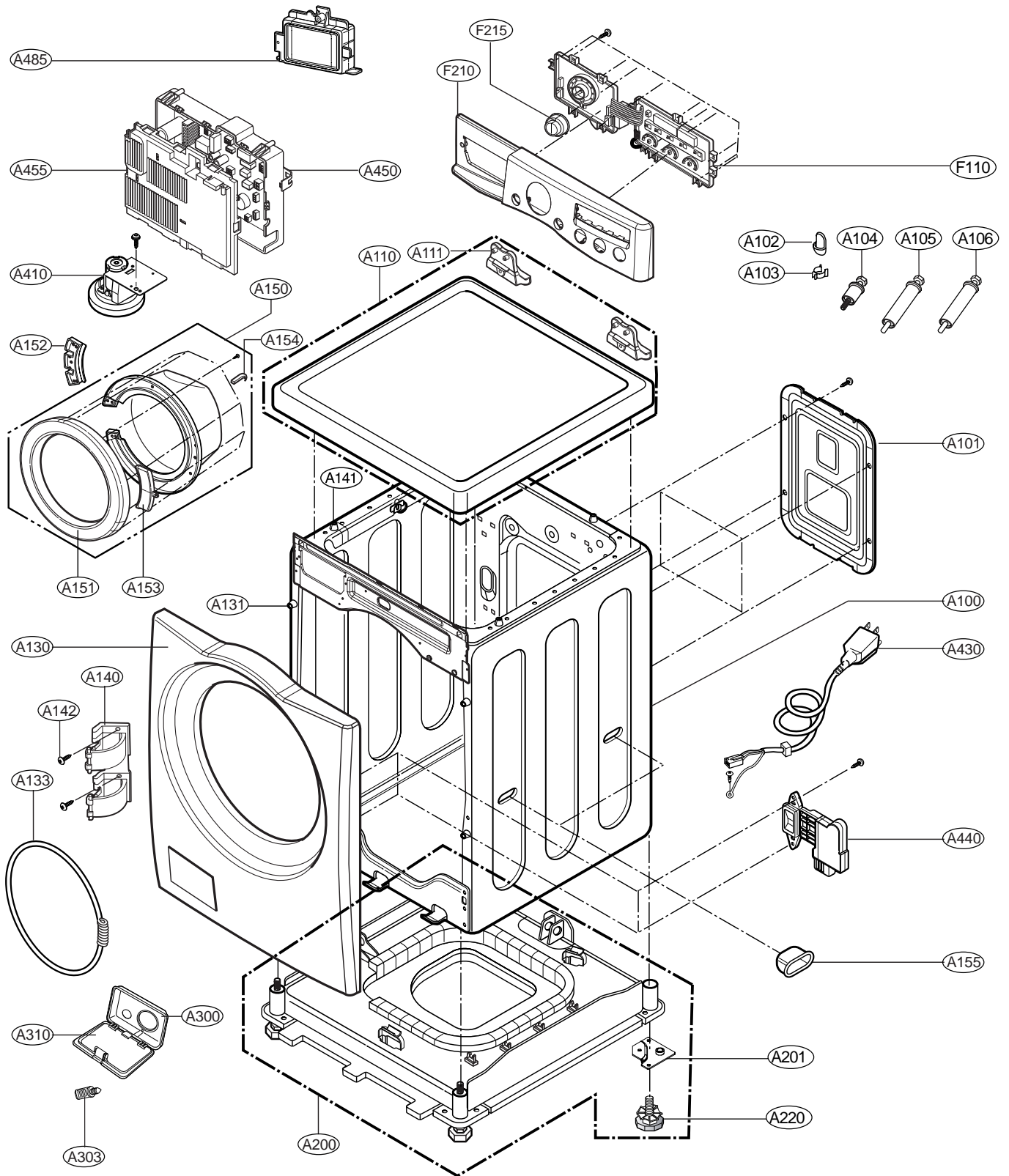

# 10-2. DRUM & TUB ASSEMBLY

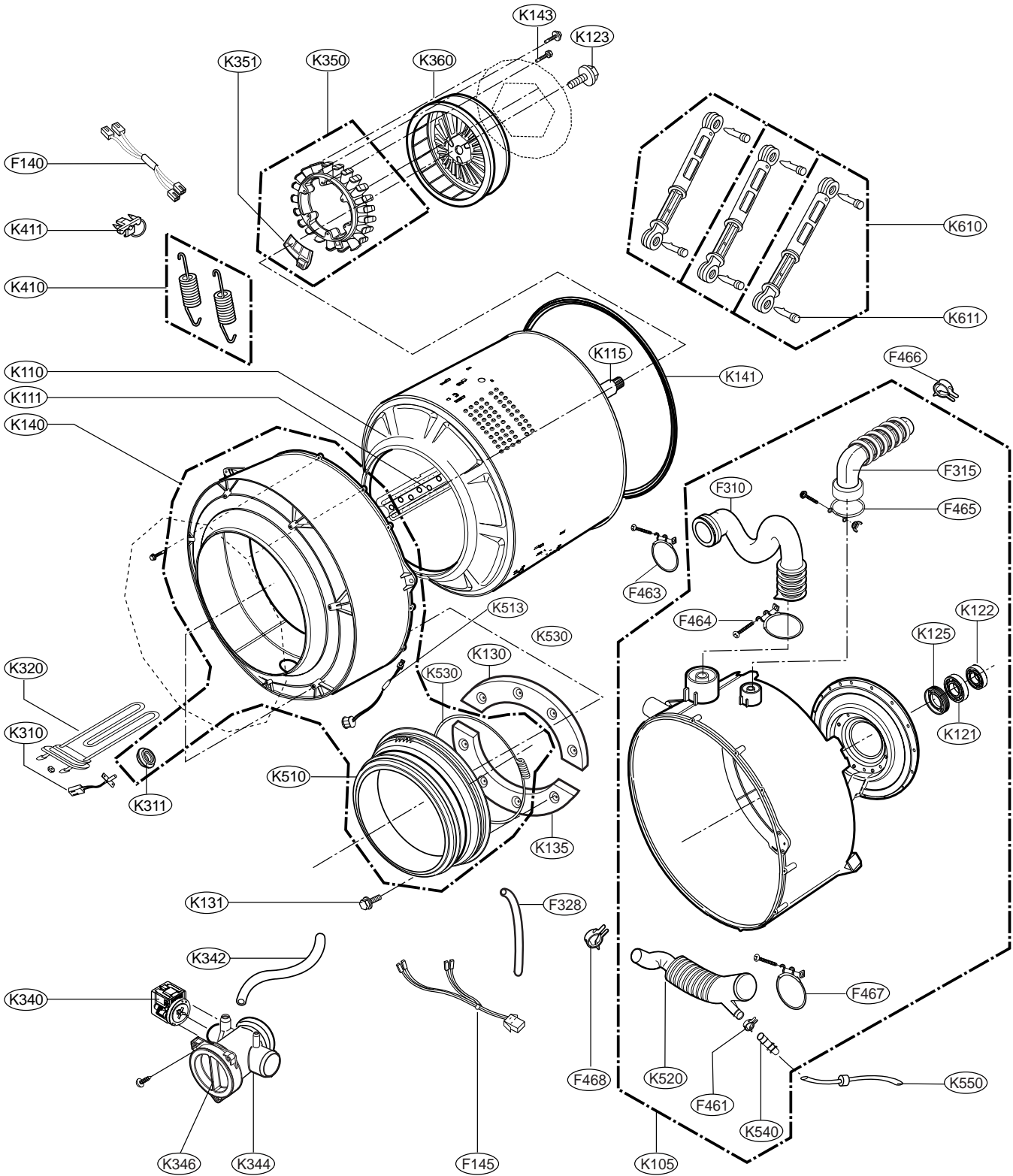

# 10-3. DISPENSER ASSEMBLY

