



LG

Website: <http://www.LGservice.com> [For U.S.A]
www.lg.ca [For Canada]

ELECTRIC & GAS DRYER SERVICE MANUAL

CAUTION

READ THIS MANUAL CAREFULLY TO DIAGNOSE
TROUBLES CORRECTLY BEFORE OFFERING SERVICE.

| | |
|-------------------------|-----------------|
| MODEL : DLE5911W | DLG5911W |
| DLE2511W | DLG2511W |
| DLE5932W | DLG5932W |
| DLE5932S | DLG5932S |
| DLE2532W | DLG2532W |
| DLE0332W | DLG0332W |



LG Electronics Inc.

MAR. 2003 PRINTED IN KOREA

P/No.:3828EL3001B

IMPORTANT SAFETY NOTICE

The information in this service guide is intended for use by individuals possessing adequate backgrounds of electrical, electronic, and mechanical experience. Any attempt to repair a major appliance may result in personal injury and property damage. The manufacturer or seller cannot be responsible for the interpretation of this information, nor can it assume any liability in connection with its use.

WARNING !

To avoid personal injury, disconnect power before servicing this product. If electrical power is required for diagnosis or test purposes, disconnect the power immediately after performing the necessary checks.

RECONNECT ALL GROUNDING DEVICES

If grounding wires, screws, straps, clips, nuts, or washers used to complete a path to ground are removed for service, they must be returned to their original position and properly fastened.

WHAT TO DO IF YOU SMELL GAS:

- Do not try to light a match, or cigarette, or turn on any gas or electrical appliance.
- Do not touch any electrical switches. Do not use any phone in your building.
- Clear the room, building or area of all occupants.
- Immediately call your gas supplier from a neighbor's phone. Follow the gas supplier's instructions carefully.
- If you cannot reach your gas supplier, call the fire department.

IMPORTANT

Electrostatic Discharge (ESD)
Sensitive Electronics

ESD problems are present everywhere. ESD may damage or weaken the electronic control assembly. The new control assembly may appear to work well after repair is finished, but failure may occur at a later date due to ESD stress.

- Use an anti-static wrist strap. Connect wrist strap to green ground connection point or unpainted metal in the appliance.

- OR -

Touch your finger repeatedly to a green ground connection point or unpainted metal in the appliance.

- Before removing the part from its package, touch the anti-static bag to a green ground connection point or unpainted metal in the appliance.
- Avoid touching electronic parts or terminal contacts; handle electronic control assembly by edges only.
- When repackaging failed electronic control assembly in anti-static bag, observe above instructions.

CONTENTS

| | |
|--|----|
| 1. SPECIFICATIONS | 4 |
| 2. FEATURES AND BENEFITS | 5 |
| 3. INSTALLATION INSTRUCTIONS | 6 |
| 4. COLUMBUS DRYER CYCLE PROCESS | 9 |
| 5. COMPONENT TESTING INFORMATION | 10 |
| 6. MOTOR DIAGRAM AND SCHEMATIC..... | 13 |
| 7. CONTROL LAY - OUT | 14 |
| 8. WIRING DIAGRAM | 15 |
| 9. DIAGNOSTIC TEST | 16 |
| 9-1. TEST 1 120VAC ELECTRICAL SUPPLY..... | 17 |
| 9-2. TEST 2 THERMISTOR TEST --- MEASURE WITH POWER OFF | 18 |
| 9-3. TEST 3 MOTOR TEST | 19 |
| 9-4. TEST 4 MOISTURE SENSOR | 20 |
| 9-5. TEST 5 DOOR SWITCH TEST | 21 |
| 9-6. TEST 6 HEATER SWITCH TEST - ELECTRIC TYPE..... | 22 |
| 9-7. TEST 7 GAS VALVE TEST - GAS TYPE | 23 |
| 10. CHANGE GAS SETTING (NATURAL GAS, PROPANE GAS) | 24 |
| 11. DISASSEMBLY INSTRUCTIONS | 26 |
| 12. EXPLODED VIEW | 32 |
| 12-1. CONTROL PANEL & PLATE ASSEMBLY | 32 |
| 12-2. CABINET & DOOR ASSEMBLY..... | 33 |
| 12-3-1. DRUM & MOTOR ASSEMBLY : ELECTRIC TYPE | 34 |
| 12-3-2. DRUM & MOTOR ASSEMBLY : GAS TYPE | 35 |
| 13. REPLACEMENT PARTS LIST | 36 |

1

SPECIFICATIONS

| ITEM | | DLE5932W DLG5932W | DLE5932S DLG5932S | DLE2532W DLG2532W | REMARK |
|-----------------------------|-------------|-----------------------------|----------------------|----------------------|-------------------------|
| Material & Finishes | Color | White | Titanium | White | |
| | Top Plate | Porcelain | Porcelain | Painted | |
| | Door Trim | Silver | Chrome | White | |
| POWER SUPPLY | | 120V / 240V 60Hz (26A) | | | |
| ELECTRICITY CONSUMPTION | MOTOR | 250W (4.5A) | | | AC 120V |
| | HEATER | 5400W (22.5A) | | | AC 240V (ELECTRIC TYPE) |
| | LAMP | 15W (125mA) | | | AC 120V |
| | GAS VALVE | 13W (110mA) X 2 | | | AC 120V (GAS TYPE) |
| CONTROL TYPE | | Electronic | | | |
| DRUM CAPACITY | | 7.3 cu.ft. | | | |
| Weight (lbs): Net / Gross | | 126 / 144 | | | |
| No. of Programs | | 9 | 9 | 5 | |
| No. of Dry Option | | 5 | 5 | 5 | |
| No. of Temperature Controls | | 5 | 5 | 5 | |
| No. of Dry Levels | | 5 | 5 | 3 | |
| Audible End of Cycle Beeper | | High / Low / Off | High / Low / Off | On / Off | |
| Sensor | Moisture | Equipped | | | Electro sensor |
| | Temperature | Equipped | | | Thermistor |
| Reversible Door | | Adopted | | | |
| Drum | | Stainless Steel | | | |
| Dryer Rack | | Equipped | | | |
| Child lock | | Equipped | | | |
| Interior Light | | Equipped | | | |
| Product (WXHxD) | | 27" x 42 3/4" x 28 1/3" | | | |
| Packing (WXHxD) | | 29 1/2" x 44 3/4" x 30 3/4" | | | |

2

FEATURES AND BENEFITS

■ DLE5911W / DLG5911W



■ DLE2511W / DLG2511W



■ DLE5932W / DLG5932W / DLE5932S / DLG5932S



■ DLE2532W / DLG2532W



3

INSTALLATION INSTRUCTIONS

3-1. POWER CORD

1) 4-wire connection

IMPORTANT: A 4-wire connection is required for mobile homes and where local codes do not permit the use of 3 wire connections.

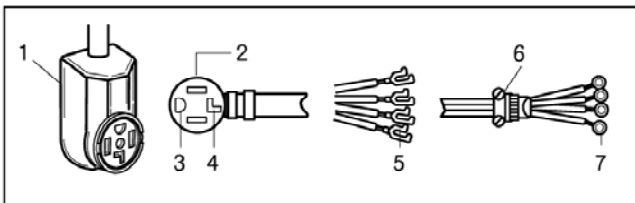

1. 4-wire receptacle (NEMA type 14-30R)
2. 4-prong plug
3. Ground prong
4. Neutral prong
5. Spade terminals with upturned ends
6. 3/4 in. (1.9 cm) UL approved strain relief
7. Ring terminals

1. Remove center terminal block screw.
2. Remove appliance ground wire (green) from external ground connector screw. Fasten it under center, silver colored terminal block screw.

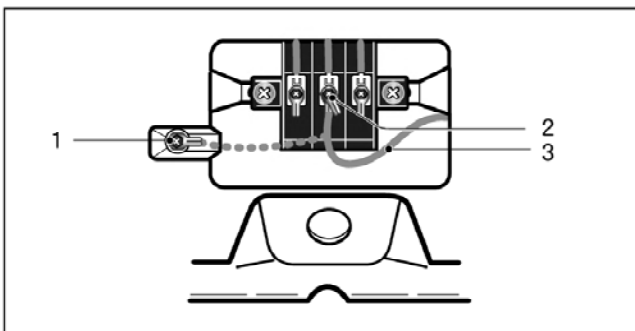

1. External ground connector - Dotted line shows position of NEUTRAL ground wire before being moved to center terminal block screw
2. Center silver-colored terminal block screw
3. Green wire of harness

3. Connect ground wire (green or bare) of power supply cable to external ground conductor screw. Tighten screw.
4. Connect neutral wire (white or center wire) of power supply cord to the center, silver colored terminal screw of the terminal block.

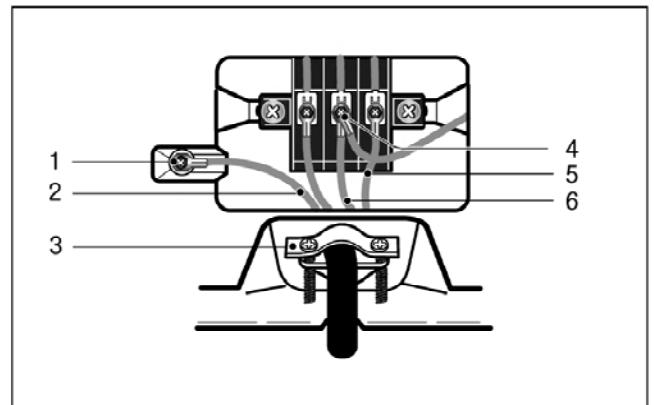

1. External ground connector
2. Green or bare copper wire of power supply cord
3. 3/4 in. (1.9 cm) UL-listed strain relief
4. Center silver-colored terminal block screw
5. Neutral grounding wire (green)
6. Neutral wire (white)

5. Connect the other wires to outer terminal block screws. Tighten screws.
6. Tighten strain relief screws.
7. Insert tab of terminal block cover into slot of dryer rear panel. Secure cover with hold-down screw.

2) 3-wire connection

Use where local codes permit connecting cabinet-ground conductor to neutral wire.

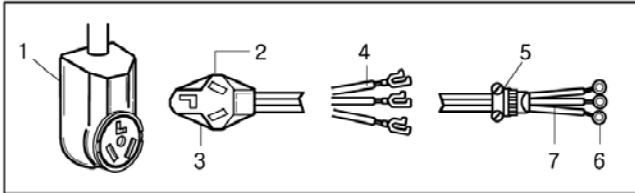

1. 3-wire receptacle (NEMA type 10-30R)
2. 3-wire plug
3. Neutral prong
4. Spade terminals with up turned ends
5. 3/4 in. (1.9 cm) UL approved strain relief
6. Ring terminals
7. Neutral (white or center wire)

1. Loosen or remove center terminal block screw.
2. Connect neutral wire (white or center wire) of power supply cord to the center, silver colored terminal screw of the terminal block. Tighten screw.

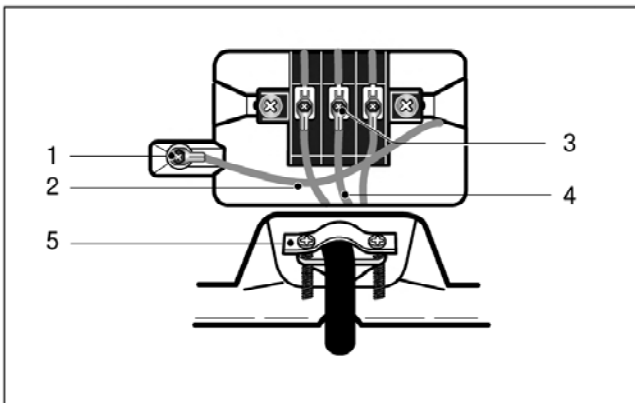

1. External ground connector
2. Neutral grounding wire (green)
3. Center silver-colored terminal block screw
4. Neutral wire (white or center wire)
5. 3/4 in. (1.9 cm) UL-listed strain relief

3. Connect the other wires to outer terminal block screws. Tighten screws.
4. Tighten strain relief screws.
5. Insert tab of terminal block cover into slot of dryer rear panel. Secure cover with hold-down screw.

3) Optional 3-wire connection

Use where local codes permit connecting cabinet-ground conductor to neutral wire.

1. Remove center terminal block screw.
2. Remove appliance ground wire (green) from external ground connector screw. Connect appliance ground wire and the neutral wire (white or center wire) of power supply cord/cable under center, silver colored terminal block screw. Tighten screw.
3. Connect the other wires to outer terminal block screws. Tighten screws.

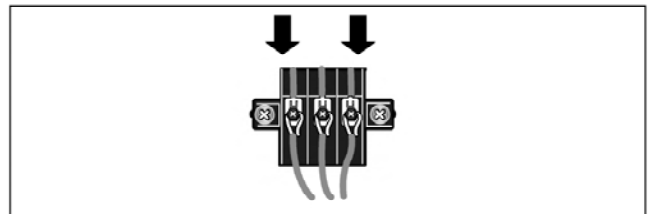

4. Tighten strain relief screws.
5. Insert tab of terminal block cover into slot of dryer rear panel. Secure cover with hold-down screw.
6. Connect a separate copper ground wire from the external ground connector screw to an adequate ground.

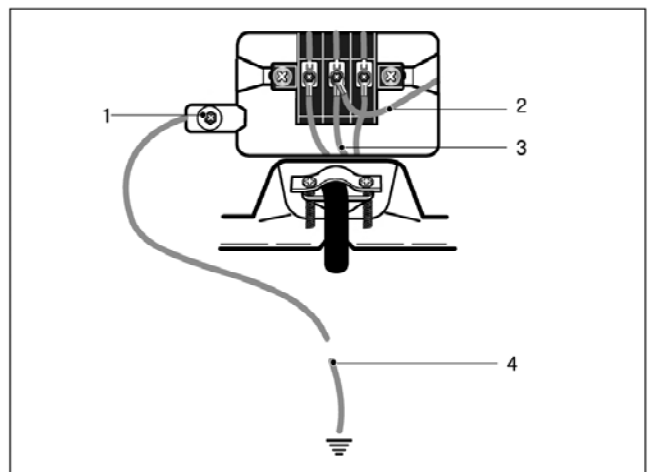

1. External ground connector
2. Neutral grounding wire (green)
3. Neutral wire (white or center wire)
4. Grounding path determined by a qualified electrician

3-2. Connect Gas Supply Pipe (Gas Dryer ONLY)

For further assistance, refer to section on **Gas Requirements**.

1. Make certain your dryer is equipped for use with the type of gas in your laundry room. Dryer is equipped at the factory for Natural Gas with a 3/8" N.P.T. gas connection.
2. Remove the shipping cap from the gas connection at the rear of the dryer. Make sure you do not damage the pipe thread when removing the cap.
3. Connect to gas supply pipe using a new flexible stainless steel connector.
4. Tighten all connections securely. Turn on gas and check all pipe connections (internal & external) for gas leaks with a non-corrosive leak detection fluid.
5. For L.P. (Liquefied Petroleum) gas connection, refer to section on Gas Requirements.

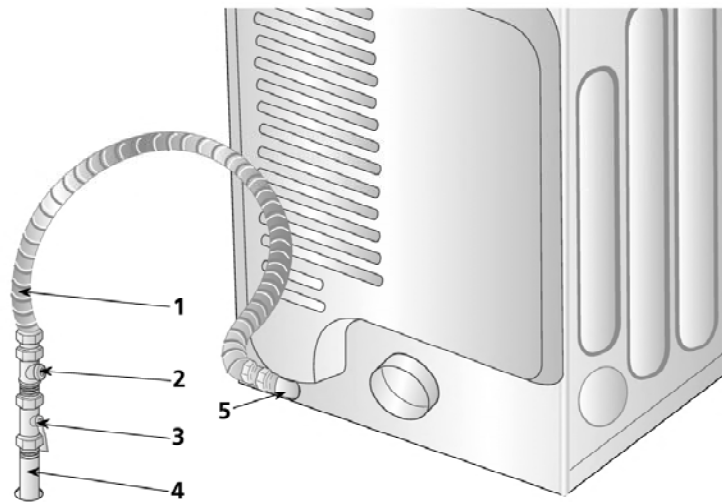

- 1 New Stainless Steel Flexible Connector - Use only if allowed by local codes (Use Design A.G.A. Certified Connector)
- 2 1/8" N.P.T. Pipe Plug (for checking inlet gas pressure)
- 3 Equipment Shut-Off Valve-Installed within 6' (1.8 m) of dryer
- 4 Black Iron Pipe
Shorter than 20' (6.1 m) - Use 3/8" pipe
Longer than 20' (6.1 m) - Use 1/2" pipe
- 5 3/8" N.P.T. Gas Connection

4

COLUMBUS DRYER CYCLE PROCESS

| Cycle | | Default | | | Conditions of operation and termination | | | | |
|--------------------------|-----------------------------|------------------|--------------|-----------------|---|------------------|-----------------|--------------------|----------------|
| | | Temp- erature | Dry Level | Display time | Drying | | Cooling | | Wrinkle care |
| | | | | | Electro- sensor | Temp- Control | Default time | Temp- Control** | Time |
| Sense Dry * | Heavy Duty | High | (Normal) | 54min | Saturation | 70±5°C | (5min) | 47±5°C | 3Hr |
| | Cotton/ Towel | Medium High | (Normal) | 55min | Saturation | 66±5°C | (5min) | 47±5°C | |
| | Normal | Medium | (Normal) | 41min | Saturation | 62±5°C | (5min) | 47±5°C | |
| | Perm. Permanent Press | Low | (Normal) | 36min | Saturation | 55±5°C | (5min) | 47±5°C | |
| | Delicate | Low | (Normal) | 32min | Saturation | 55±5°C | (5min) | 38±5°C | |
| | Ultra Delicate | Extra low | (Normal) | 34min | Saturation | 45±5°C | (5min) | 38±5°C | |
| Manual Dry ** | Speed dry | (High) | - | 25min | Saturation | (70±5°C) | (5min) | (47±5°C) | 3Hr |
| | Freshen Up | (Medium High) | - | 20min | Saturation | (66±5°C) | (5min) | (47±5°C) | |
| | Air dry | - | - | 30min | Saturation | No heater | N/A | N/A | |
| Load | | Motor | | | | | | | Off Time: 6min |
| | | | | | | | | | On Time: 10sec |
| Load | | Heater | | | | | | | |
| | | | | | Temperature Control for each cycle | | | | |

* Sense dry : "Dry Level" is set by users.

** Manual dry : "Temperature control" is set by users.



Default settings can be adjusted by users.

5

COMPONENT TESTING INFORMATION

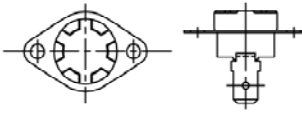
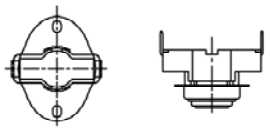
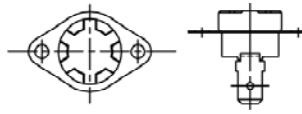
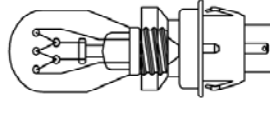
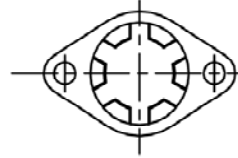
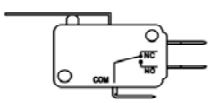
⚠ CAUTION When checking the Component, be sure to turn the power off, and do voltage discharge sufficiently.

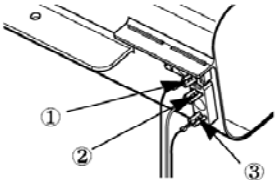
| Component | Test Procedure | Check result | Remark |
|---|--|--|---|
| 1. Thermal cut off  • Check Top Marking : N130 | Measure resistance of terminal to terminal ① Open at $266 \pm 12^{\circ}\text{F}$ ($130 \pm 7^{\circ}\text{C}$) ② Auto reset -31°F (-35°C) Same shape as Outlet Thermostat. | If thermal fuse is open must be replaced ① Resistance value $\approx \infty$ ② Continuity (250°F ↓) $< 1\Omega$ | <ul style="list-style-type: none"> • Heater case-Safety • Electric type |
| 2. Hi limit Thermostat (Auto reset)  | Measure resistance of terminal to terminal ① Open at $257 \pm 9^{\circ}\text{F}$ ($125 \pm 5^{\circ}\text{C}$) ② Close at $221 \pm 9^{\circ}\text{F}$ ($105 \pm 5^{\circ}\text{C}$) | ① Resistance value $\approx \infty$ ② Resistance value $< 5\Omega$ | <ul style="list-style-type: none"> • Heater case - Hi limit • Electric type |
| 3. Outlet Thermostat (Auto reset)  • Check Top Marking : N85 | Measure resistance of terminal to terminal ① Open at $185 \pm 9^{\circ}\text{F}$ ($85 \pm 5^{\circ}\text{C}$) ② Close at $149 \pm 9^{\circ}\text{F}$ ($65 \pm 5^{\circ}\text{C}$) Same shape as Thermal cut off. | ① Resistance value $\approx \infty$ ② Resistance value $< 5\Omega$ | <ul style="list-style-type: none"> • Blow housing - Safety • Electric type |
| 4. Lamp holder  | Measure resistance of terminal to terminal | Resistance value : $80\Omega \sim 100\Omega$ | |
| 5. Door switch  | Measure resistance of the following terminal 1) Door switch knob : open ① Terminal : "COM" - "NC" (1-3) ② Terminal : "COM" - "NO" (1-2) 2) Door switch push : push ① Terminal : "COM" - "NC" (1-3) ② Terminal : "COM" - "NO" (1-2) | ① Resistance value $< 1\Omega$ ② Resistance value $\approx \infty$ ① Resistance value $\approx \infty$ ② Resistance value $< 1\Omega$ | The state that Knob is pressed is opposite to Open condition. |
| 6. Idler switch  | Measure resistance of the following terminal : "COM - NC" | 1. lever open ① Resistance value $< 1\Omega$ 2. Lever push (close) ② Resistance value $\approx \infty$ | |

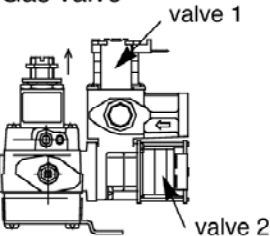
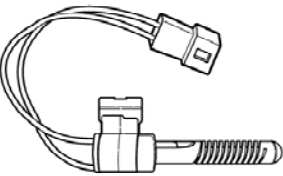
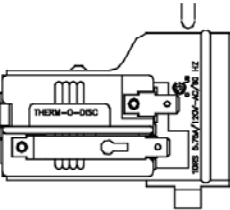
| Component | Test Procedure | Check result | Remark |
|---|--|--|---|
| 7. Heater  | Measure resistance of the following terminal ① Terminal : 1 (COM) - 2 ② Terminal : 1 (COM) - 3 ③ Terminal : 2 - 3 | ① Resistance value : 10Ω ② Resistance value : 10Ω ③ Resistance value : 20Ω | <ul style="list-style-type: none"> • Electric type |
| 8. Thermistor  | Measure resistance of terminal to terminal Temperature condition : 58°F ~ (10~40°C) 58°F ~ 104F (10~40°C) | Resistance value : 10Ω | <ul style="list-style-type: none"> • Heater case - Hi limit • Electric type |
| 9. Motor | | | <ul style="list-style-type: none"> • See Page 13 |
| 10. Gas valve  | Measure resistance of the following terminal ① Valve 1 terminal ② Valve 2 terminal | ① Resistance value : > 1.5kg ~ ② Resistance value : > 1.5~2.5kg | <ul style="list-style-type: none"> • Gas type |
| 11. Igniter  | Measure resistance of terminal to terminal | Resistance value : 100~800Ω | <ul style="list-style-type: none"> • Gas type |
| 12. Frame Detect  | Measure resistance of terminal to terminal ① Open at 370°F ((Maximum) ② Close at 320°F | ① Resistance value = ∞ ② Resistance value < 1Ω | <ul style="list-style-type: none"> • Gas type |

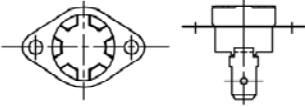
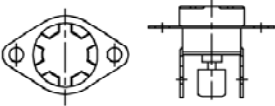
| Component | Test Procedure | Check result | Remark |
|---|---|--|------------------------------------|
| <p>13. Outlet Thermostat (Auto reset)</p>  <p>• Check Top Marking : N95</p> | <p>Measure resistance of terminal to terminal</p> <p>① Open at $203 \pm 7^{\circ}\text{F}$ ($95 \pm 5^{\circ}\text{C}$) ② Close at $158 \pm 9^{\circ}\text{F}$ ($70 \pm 5^{\circ}\text{C}$)</p> | <p>① Resistance value $\approx \infty$ ② Continuity $< 1\Omega$</p> | <p>• Gas type • Gas funnel</p> |
| <p>13. Outlet Thermostat (Manual reset)</p>  <p>• Check Top Marking : N100</p> | <p>Measure resistance of terminal to terminal</p> <p>① Open at $212 \pm 12^{\circ}\text{F}$ ($100 \pm 7^{\circ}\text{C}$) ② Manual reset</p> | <p>If thermal fuse is open must be replaced</p> <p>① Resistance value $\approx \infty$ ② Continuity $< 1\Omega$</p> | <p>• Gas type • Gas funnel</p> |

6

MOTOR DIAGRAM AND SCHEMATIC

NOTE When checking Component, be sure to turn Power off, then do voltage discharge sufficiently.

- Contact On / Off by Centrifugal Switch

| Terminal No | | ① | ② | ③ | ④ | ⑤ | ⑥ | Remark |
|-------------|------------|---|---|---|---|---|---|--------------------------|
| Mode | Resistance | | | | | | | |
| Motor STOP | 2 ~ 3Ω | | | | ● | ● | | Motor |
| | ≒ ∞ | ● | ● | | | | | Heater (Electric Models) |
| | ≒ ∞ | | | ● | | | ● | Gas Valve (Gas Models) |
| Motor RUN | 3 ~ 5Ω | | | | ● | ● | | Motor |
| | < 1Ω | ● | ● | | | | | Heater (Electric Models) |
| | < 1Ω | | | ● | | | ● | Gas Valve (Gas Models) |

..... Open
 ——— Close

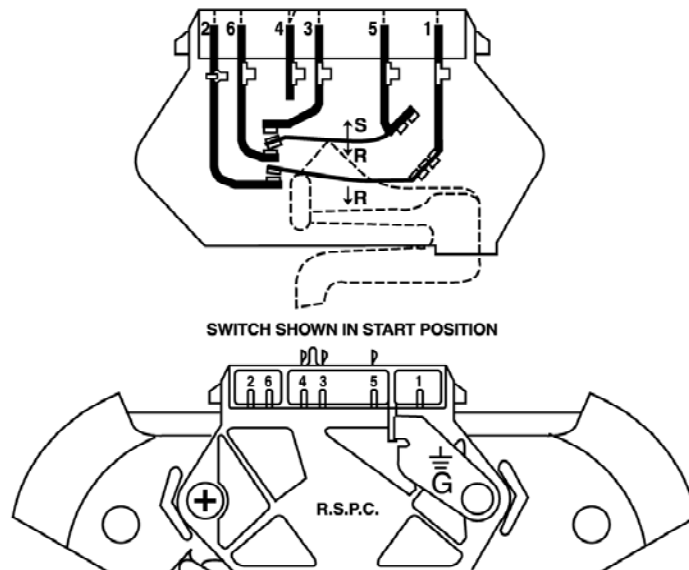

- STOP MODE
(When Motor does not operate)

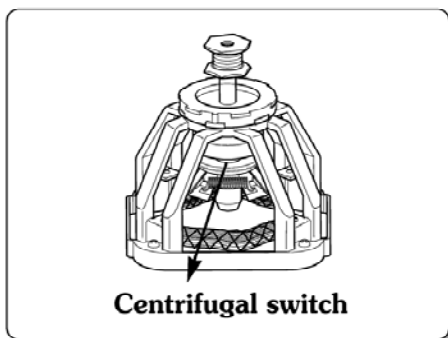

- RUN MODE
(Motor operates)

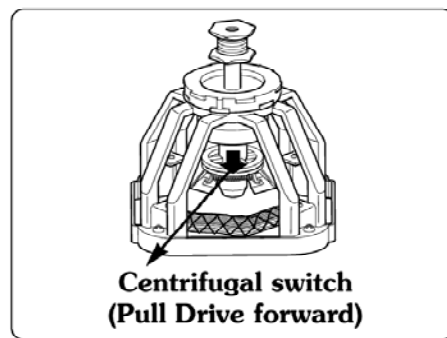

7

CONTROL LAY-OUT

PWB ASSEMBLY DISPLAY LAY-OUT

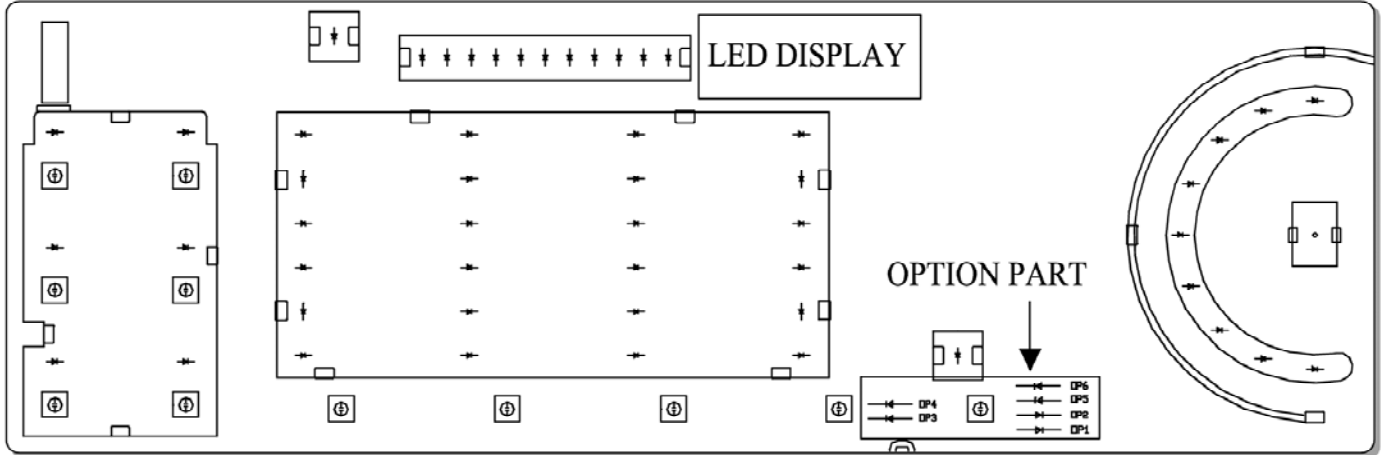

※ MODEL DISPLAY AS DIAGNOSTIC TEST

| MODEL | OPTION PART | | | | | | LED DISPLAY | P/No |
|------------|-------------|------|------|------|------|------|-------------|-------------|
| | OP 1 | OP 2 | OP 3 | OP 4 | OP 5 | OP 6 | | |
| DLE5932W/S | X | X | X | X | X | X | 18:20 | 6871EC2025F |
| DLG5932W | X | X | O | X | X | X | 19:20 | 6871EC2025G |
| DLE5911W | X | O | X | X | X | X | 18:21 | 6871EC2025H |
| DLG5911W | X | O | O | X | X | X | 19:21 | 6871EC2025J |

PWB ASSEMBLY LAY-OUT

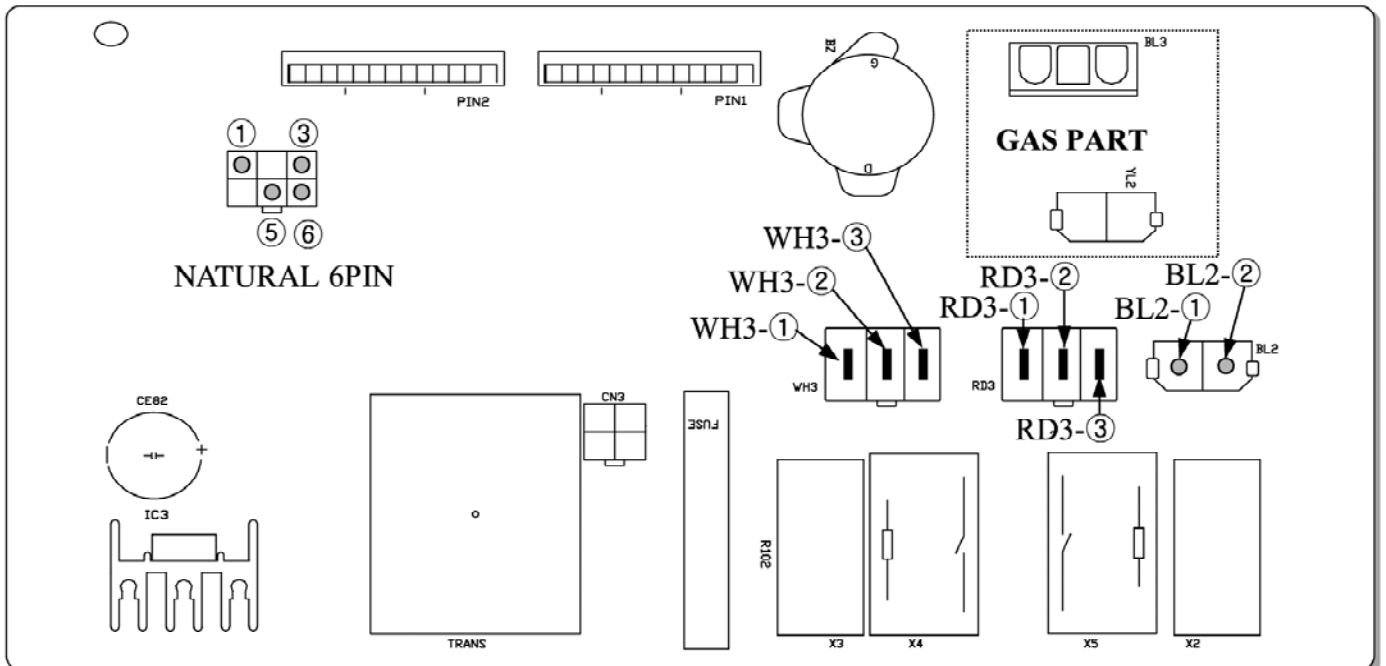

ELECTRIC DRYER WIRING DIAGAM

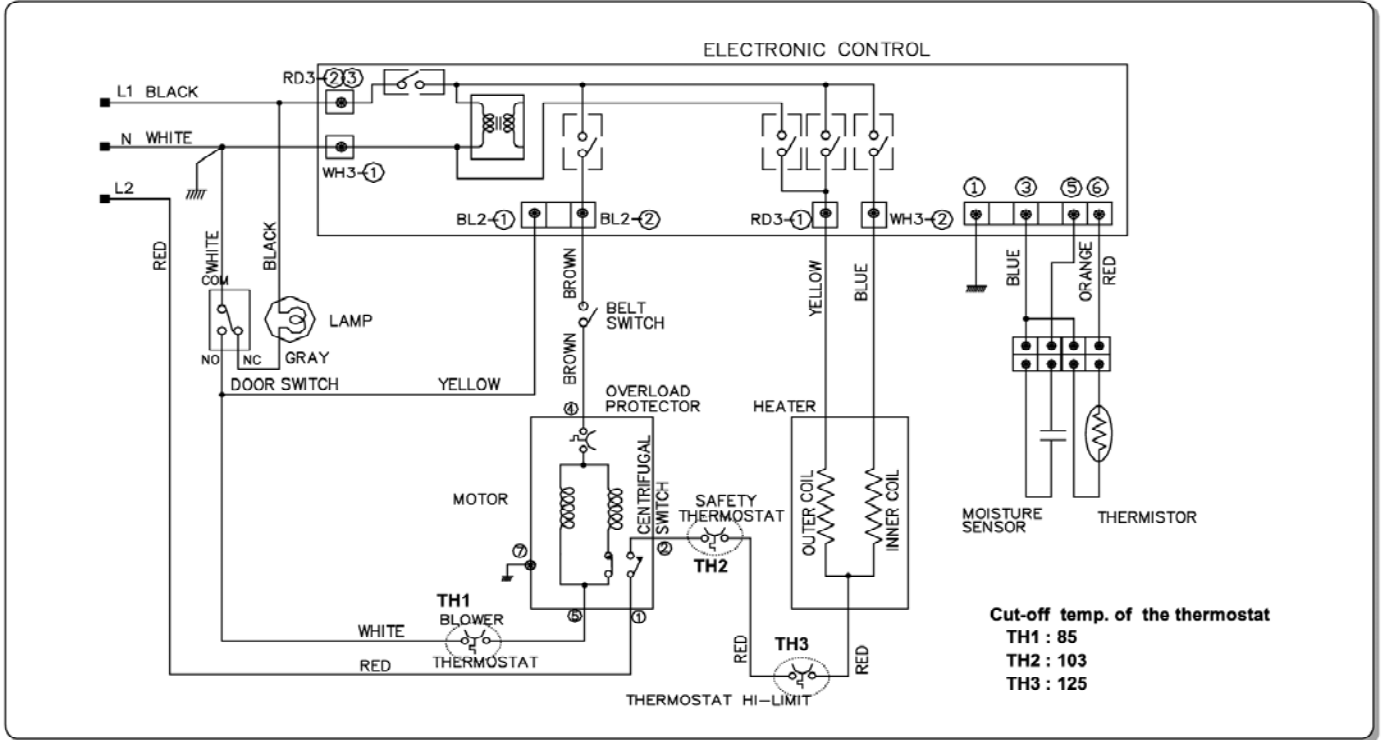

GAS DRYER WIRING DIAGAM

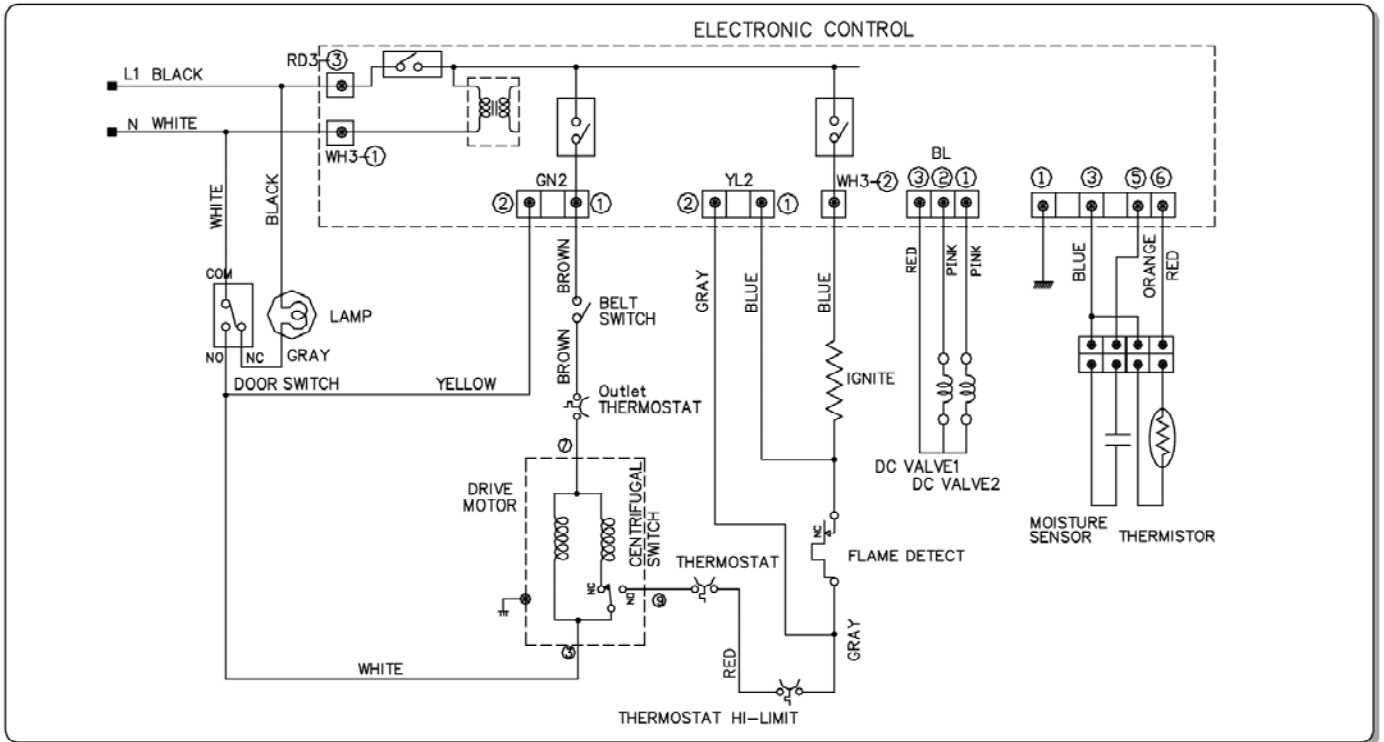

9

DIAGNOSTIC TEST

1. This TEST should be used for Factory test /Service test. Do not use this DIAGNOSTIC TEST other than specified.
2. Activating the Heater manually with the Door open may trip the Thermostat attached to the Heater, therefore do not activate it manually. (Do not press the door switch to operate the heater while the door is open)

■ ACTIVATING THE DIAGNOSTIC TEST MODE

1. Unit must be in Standby (unit plugged in, display off)
2. Press "POWER" while pressing "MORE TIME", and "LESS TIME" simultaneously.

| Pressing the "START/PAUSE" button | CHECKING ACTION | DISPLAY | CHECKING POINT | REMARK |
|---|--|---|--|---|
| None | Electric control & Temperature sensor |  | Won't power up Defective LED | See test 1 Display : See page |
| | | 1E 0E | Thermistor open | See test 2 |
| | | 1E 0E | Thermistor close | |
| Once | Motor | 70 ~ 237 Measured Moisture Value. | Motor runs | See test 3 |
| | | | Displays Moisture Sensor Operation: If moisture sensor is contacted with damp cloth. The display number is below 180, in normal condition. | See test 4 |
| Twice | <ul style="list-style-type: none"> ■ ELECTRIC TYPE Motor + Heater 1 (1250W) ■ GAS TYPE Motor + Valve | Current Temp. | <ul style="list-style-type: none"> ■ ELECTRIC TYPE : Heater runs ■ GAS TYPE : GAS Valve runs (Display the Temperature of Inside drum.) | Gas valve See test 7 |
| 3 times | <ul style="list-style-type: none"> ■ ELECTRIC TYPE Motor + Heater 1 + Heater 2 (5400W) ■ GAS TYPE Motor Type | Current Temp. (5 ~ 70) | In normal state if displayed temp. is increasing. Temperature in 4min : 113°F (45°C) • Above : 1" on , 1" off beep sound • Under : 0.5" on, 0.5" off beep sound | See test 5 ※ Off automatically after 5 minutes |
| During check, If the door is open. | Motor & Heater Off + Lamp On + Buzzer beeps five times | dE | Door switch | See test 6 |
| | | | Lamp | |
| During check, If the door is closed. | Motor & Heater Off + Lamp Off | 70 ~ 237 | Return once "1time" (See test 4) state. | |
| 4 times | Control Off | | Auto Off | |

■ Test 1 120VAC Electrical supply

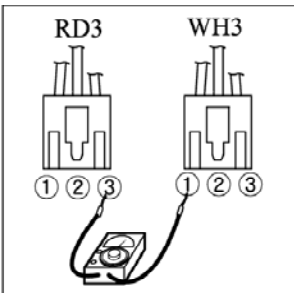
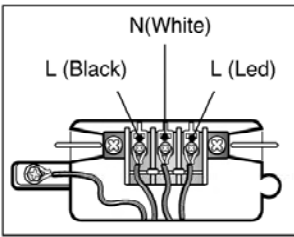
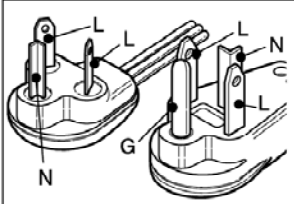
| | | |
|---|--|---|
| Caution | When measuring power, be sure to wear insulated gloves, to and avoid an electric shock. | |
| Trouble Symptom | No power was applied to Controller. (LED, Display off) | |
| Measurement Condition | With Dryer Power On; Connector linked to Controller. | |
|  | Check the outlet, is the voltage 110V ~ 125V AC? | <p>NO</p> <ul style="list-style-type: none"> • Check the fuse or circuit breaker. |
| YES | | |
|  | Check if the voltage measured between Connector "RD3-③" (Black) linked to the Controller and "WH3-①" (White) is 110V ~ 125V? | <p>NO</p> <ul style="list-style-type: none"> • Check if Power Cord is properly connected. |
| YES | | |
|  | <p>① Check if the Controller wire is disconnected.</p> <p>② Check if Terminal Block and Power Cord are connected (Check Plug). - Does Power Cord N(Natural) line match to Terminal Center N(Natural) line?</p> | <p>NO</p> <ul style="list-style-type: none"> • Reconnect the controller. |
| YES | | |
|  | Replace controller. | |

■ Test 2 Thermistor Test --- Measure with Power Off

| | |
|------------------------------|---|
| Caution | Before measuring resistance, be sure to turn Power off, and do voltage discharge. (When discharging, contact the metal plug of Power cord with the Ground.) |
| Trouble Symptom | <ul style="list-style-type: none"> ① During Diagnostic Test, tE1 and tE2 Error occur. ② During operation, Heater would not turn off, or remains on. ③ Difference between actual and sensed temperature is significant. |
| Measurement Condition | After turning Power off, measure the resistance. |

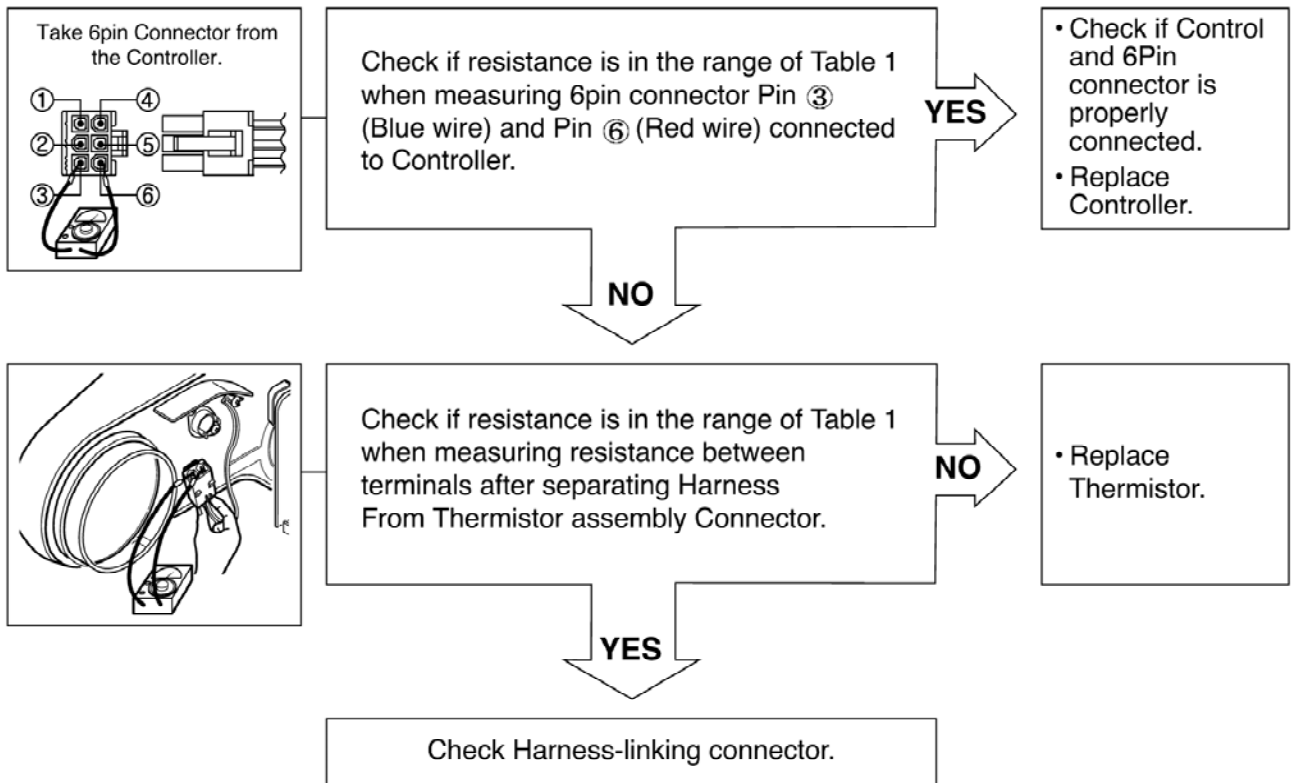

■ Table 1. Resistance for Thermistor Temperature.

| Air TEMP.[°F (°C)] | RES. [kΩ] | Air TEMP.[°F (°C)] | RES. [kΩ] | Air TEMP.[°F (°C)] | RES. [kΩ] |
|--------------------|-----------|--------------------|-----------|--------------------|-----------|
| 50°F (10°C) | 18.0 | 90°F (32°C) | 7.7 | 130°F (54°C) | 2.9 |
| 60°F (16°C) | 14.2 | 100°F (38°C) | 6.2 | 140°F (60°C) | 3.0 |
| 70°F (21°C) | 11.7 | 110°F (43°C) | 5.2 | 150°F (66°C) | 2.5 |
| 80°F (27°C) | 9.3 | 120°F (49°C) | 4.3 | 160°F (71°C) | 2.2 |

■ Test 3 Motor test

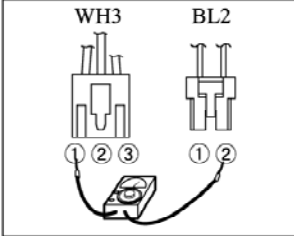
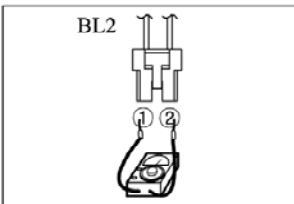
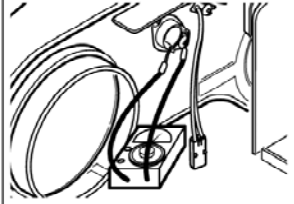
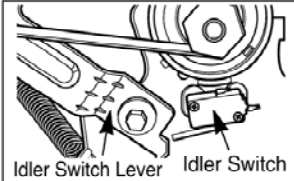
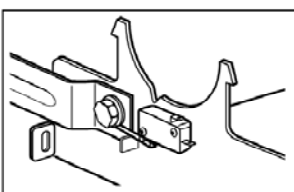
| | | |
|--|--|---|
| Caution | Before measuring resistance, be sure to turn Power off, and do voltage discharge. (When discharging, contact the metal plug of Power cord with earth line.) | |
| Trouble Symptom | Drum will not rotate; No fan will function; No Heater will work. | |
| Measurement Condition | Turn the Dryer's Power Off, then measure resistance. | |
|      | <p>Is resistance below 3Ω between Connector "WH3-①" (White wire) and "BL2-②" (Brown wire)? ※ Measure while door is closed.</p> <p>Is resistance below 3Ω between Connector "WH3-①" (White wire) and "BL2-①" (Yellow wire)? ※ Measure while door is closed.</p> <p>Is resistance below 3Ω between Connector "BL2-①" (Yellow wire) and "BL2-②" (Brown wire)?</p> <p>Is resistance below 1Ω between terminals of Outlet Thermostat attached to blower housing?</p> <p>Does Idle Switch attached to Motor Bracket operate Level by drum belt? (Not operating Lever is normal.)</p> <p>Is resistance below 1Ω between Idler Switch terminals?</p> | <p>YES</p> <ul style="list-style-type: none"> • Replace Control. (Relay check) • Check Controller connector. <p>NO</p> <ul style="list-style-type: none"> • Check if Door flame presses door switch knob. • Check Door Switch. • Check Harness connection. <p>YES</p> <ul style="list-style-type: none"> • Replace Control. (Relay check) • Check Controller connector. <p>NO</p> <ul style="list-style-type: none"> • Replace Outlet Thermostat. • Check if Component is attached to blower housing. <p>YES</p> <ul style="list-style-type: none"> • Check Idler Assembly. • Drum Belt cuts off • Drum Belt takes off from Motor Pulley. <p>NO</p> <ul style="list-style-type: none"> • Replace Idler Switch. <p>YES</p> <ul style="list-style-type: none"> • Check Motor. (Refer to 'Motor Diagram & Check') • Check if Control Connector is contacted. |

■ Test 4 Moisture sensor

| | |
|------------------------------|---|
| Caution | Before measuring resistance, be sure to turn Power off, and do voltage discharge. (When discharging, contact the metal plug of Power cord with earth line.) |
| Trouble Symptom | Degree of dryness does not match with Dry Level. |
| Measurement Condition | Turn the Dryer's Power Off, then measure resistance. |

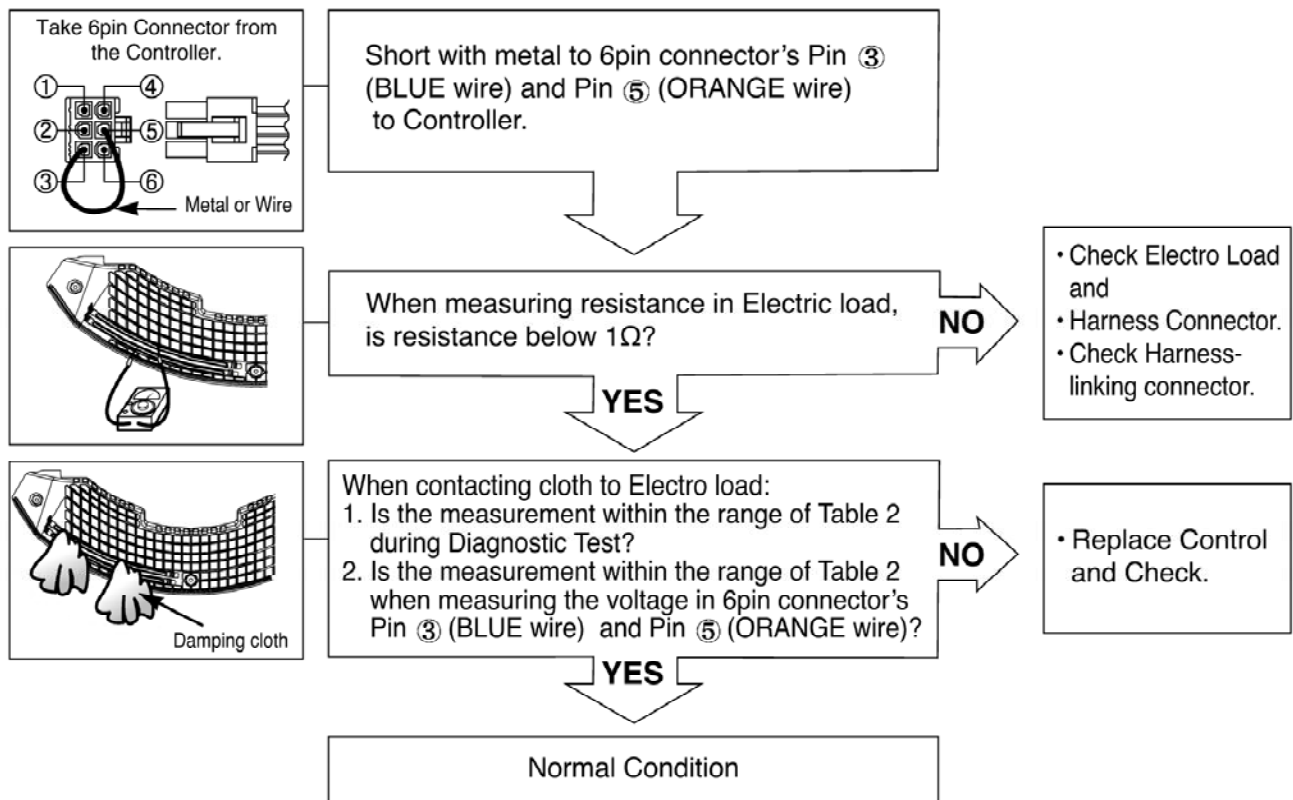

■ Table 2. IMC Ratio and Display Value / Voltage (IMC : Initial Moisture Content)

| IMC | Display Value | Voltage(DC) (between 6Pin terminal ③,⑤) | Remark |
|---------------------|---------------|---|--|
| 70% ~ 40% | 50 ~ 130 | 2.5V | Weight after removing from Washing Machine |
| 40% ~ 20% | 100 ~ 20 | 2.0V ~ 4.0V | Damp Dry |
| 10% ~ Dried clothes | 205 ~ 240 | Over 4.0V | Completely-dried clothes |

■ Test 5 Door switch test

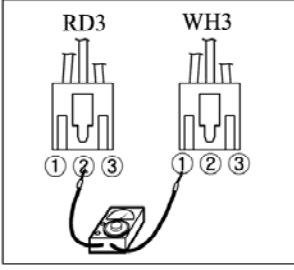
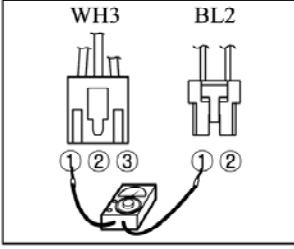
| | |
|---|--|
| Caution | Before measuring resistance, be sure to turn Power off, and do voltage discharge. (When discharging, contact the metal plug of Power cord with earth line.) |
| Trouble Symptom | Door Opening is not sensed. (During operation, when opening Door, Drum motor and Heater run continuously; Door Close is not sensed. (Drum motor will not operate. Display will flash at 0.5 second intervals.) |
| Measurement Condition | After turning Dryer Power Off, measure resistance. |
| <div style="display: flex; flex-direction: column; align-items: flex-start;"> <div style="display: flex; width: 100%; margin-bottom: 10px;"> <div style="width: 20%; text-align: center;">  </div> <div style="width: 70%; padding-left: 10px;"> <p>Measure while Door is closed. Check if resistance is below 250Ω between “WH3-①” (White wire) and “RD3-②” (Black wire) Connector WH3, RD3 after taking WH3, RD3 out from Controller.</p> <p style="text-align: right;">YES →</p> </div> <div style="width: 10%; text-align: center;"> <p>NO ↓</p> </div> </div> <div style="display: flex; width: 100%; margin-bottom: 10px;"> <div style="width: 20%;"></div> <div style="width: 70%; padding-left: 10px;"> <p>Measure while Door is open. Check if resistance is 300~60Ω between “WH3-①” (White wire) and “RD3-②” (Black wire) Connector WH3, RD3 after taking WH3, RD3 out from Controller.</p> <p style="text-align: right;">NO →</p> </div> <div style="width: 10%; text-align: center;"> <p>YES ↓</p> </div> </div> <div style="display: flex; width: 100%; margin-bottom: 10px;"> <div style="width: 20%; text-align: center;">  </div> <div style="width: 70%; padding-left: 10px;"> <p>Measure while Door is open. Check if resistance is below 1Ω between “BL2-①” (Yellow wire) and “WH3-①” (White wire) after taking Connector WH3, BL2 out from Controller.</p> <p style="text-align: right;">YES →</p> </div> <div style="width: 10%; text-align: center;"> <p>NO ↓</p> </div> </div> <div style="display: flex; width: 100%; margin-bottom: 10px;"> <div style="width: 20%;"></div> <div style="width: 70%; padding-left: 10px;"> <p>Measure while Door is closed. Check if resistance is below 1Ω between “BL2-①” (Yellow wire) and “WH3-①” (White wire) after taking Connector WH3, BL2 out from Controller.</p> <p style="text-align: right;">NO →</p> </div> <div style="width: 10%; text-align: center;"> <p>YES ↓</p> </div> </div> <div style="width: 100%; text-align: center; border: 1px solid black; padding: 5px;"> <p>Check Controller. Check Harness-linking connector.</p> </div> </div> <div style="display: flex; flex-direction: column; align-items: flex-end; margin-top: 10px;"> <div style="width: 80%; border: 1px solid black; padding: 5px; margin-bottom: 10px;"> <ul style="list-style-type: none"> • Door switch Check (Refer to Component testing.) </div> <div style="width: 80%; border: 1px solid black; padding: 5px; margin-bottom: 10px;"> <ul style="list-style-type: none"> • Check Lamp. (When opening Lamp, replace then measure again.) • Door switch Check (Refer to Component testing.) </div> <div style="width: 80%; border: 1px solid black; padding: 5px; margin-bottom: 10px;"> <ul style="list-style-type: none"> • Door switch Check (Refer to Component testing.) </div> <div style="width: 80%; border: 1px solid black; padding: 5px;"> <ul style="list-style-type: none"> • Door switch Check (Refer to Component testing.) </div> </div> | |

■ Test 6 Heater switch test - Electric Type

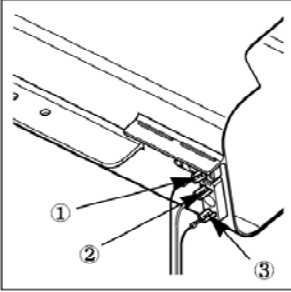
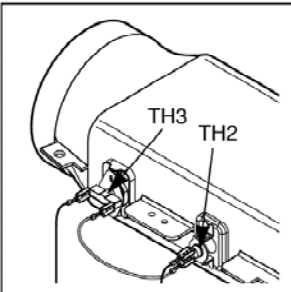
| | | |
|---|---|---|
| Caution | Before measuring resistance, be sure to turn Power off, and do voltage discharge. (When discharging, contact the metal plug of Power cord with earth line.) | |
| Trouble Symptom | While operating, Heating will not work. Drying time takes longer. | |
| Measurement Condition | After turning Power off, measure the resistance. | |
|  | <ol style="list-style-type: none"> 1. Is resistance between Heater terminal ① and ② below 18 ~ 22Ω? 2. Is resistance between Heater terminal ① and ③ below 18 ~ 22Ω? 3. Is resistance between Heater terminal ② and ③ below 9 ~ 11Ω? | <p>NO</p> <ul style="list-style-type: none"> • Replace Heater. |
| | YES | |
|  | Check if the value of measured resistance is below 1Ω between terminal TH2 (Safety Thermostat). | <p>NO</p> <ul style="list-style-type: none"> • Replace TH2 (Safety Thermostat). |
| | YES | |
| | Check if the value of measured resistance is below 1Ω between terminal TH3 (HI-Limit Thermostat). | <p>NO</p> <ul style="list-style-type: none"> • Replace TH3 (HI-Limit Thermostat). |
| | YES | |
| | Check Motor. Check if the value of measured resistance is below 1Ω between terminal ① and ⑩ at RUN condition. | <p>NO</p> <ul style="list-style-type: none"> • Check Motor and replace it. |
| | YES | |
| | Check Controller. Check Harness-linking Connector. | |

■ Test 7 GAS Valve test - Gas Type

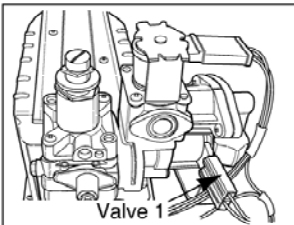
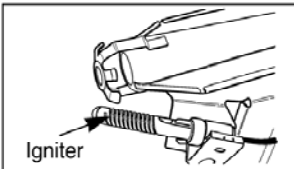
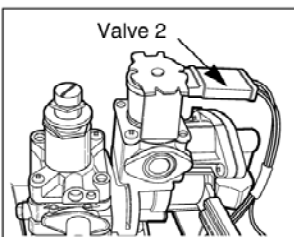
| | |
|--|--|
| Caution | When measuring power, be sure to wear insulated gloves, to avoid electric shock. |
| Trouble Symptom | While operating, Heating will not work. Drying time takes longer. |
| Measurement Condition | With dryer power on |
| <div style="display: flex; align-items: flex-start;"> <div style="margin-right: 20px;">  <p>Valve 1</p> </div> <div style="margin-right: 20px;">  <p>Igniter</p> </div> <div style="margin-right: 20px;">  <p>Valve 2</p> </div> <div> <p>Power On & Start (Normal Cycle)</p> <p style="text-align: center;">NO</p> <p>When measuring Valve 1 voltage, More than AC 90V?</p> <p style="text-align: right;">NO</p> <ul style="list-style-type: none"> • Check thermostat Hi limit Safety <p style="text-align: center;">YES</p> <p>Igniter operates? (after 1 min, Igniter becomes reddish)</p> <p style="text-align: right;">NO</p> <ul style="list-style-type: none"> • Check Igniter & Frame detect <p style="text-align: center;">YES</p> <p>When measuring Valve 2 voltage, Value is more than AC 90V? (10 sec after Igniter off)</p> <p style="text-align: right;">YES</p> <ul style="list-style-type: none"> • Check Gas connection or Gas supply <p style="text-align: center;">NO</p> <p>When measuring terminal resistance on "Valve 1", "Valve 2", Value is more than 1.5 ~ 2.5kΩ? (Measure after Off)</p> <p style="text-align: right;">YES</p> <ul style="list-style-type: none"> • Change Valve <p style="text-align: center;">NO</p> <ul style="list-style-type: none"> • Harness check • Controller change </div> </div> | |

10

CHANGE GAS SETTING (NATURAL GAS, PROPANE GAS)

⚠ Warning

After Natural Gas Setting, applying Propane Gas Orifice or wrong use of Natural Gas Orifice will result in fire. Conversion must be made by a qualified technician.

Initially, Natural Gas mode is set. Propane Gas Orifice is on sale as a Service Part to authorized servicers only.

STEP 1 : VALVE SETTING

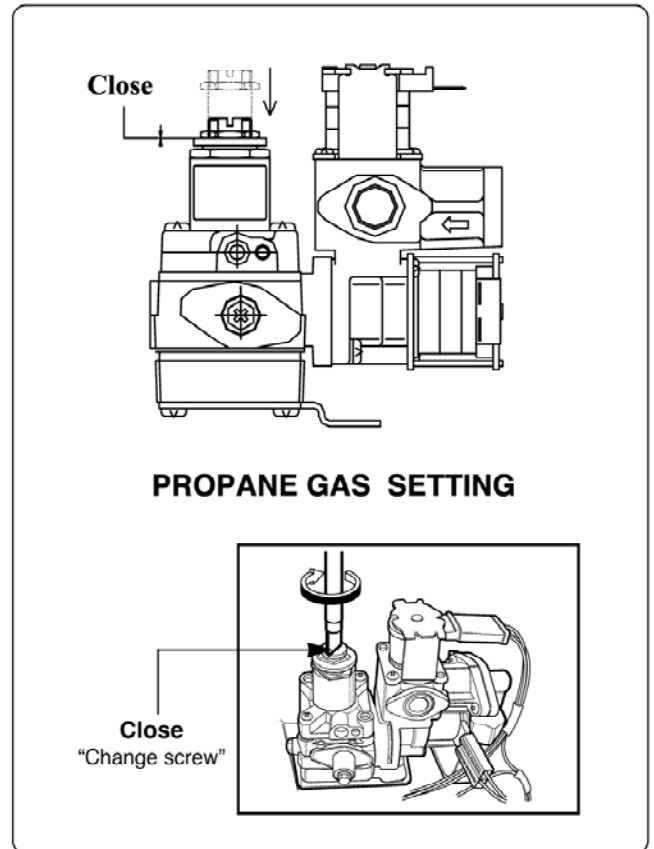
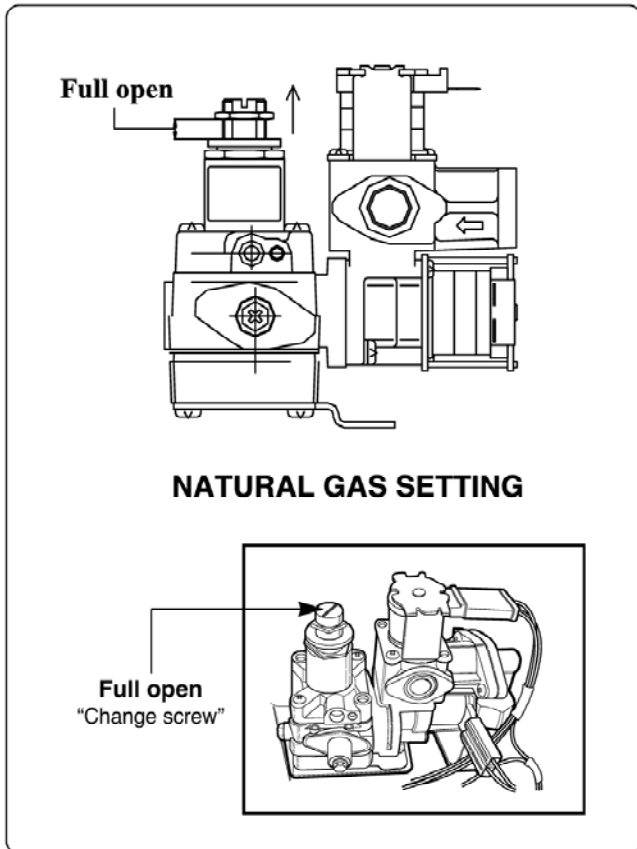

STEP 2 : ORIFICE CHANGE

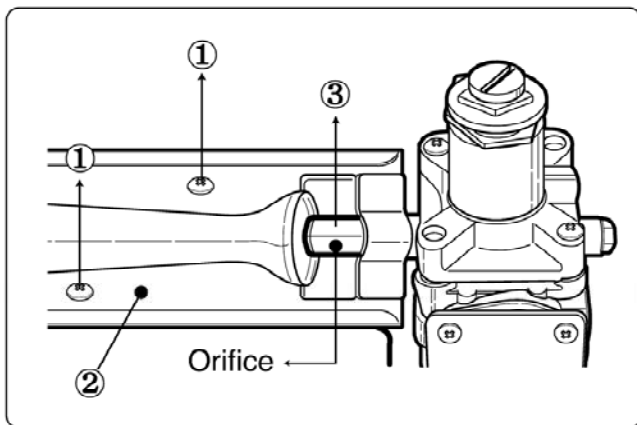

- ① Remove 2 screws.
- ② Disassemble the pipe assembly.
- ③ Replace Natural Gas orifice with Propane Gas orifice.

| Gas type | Orifice P/No | Marking | Shape |
|-------------|--------------|---------|-------|
| Natural Gas | 4948EL4001B | NCU | |
| Propane Gas | 4948EL4002B | PCU | |

※ **Kit contents** : Orifice (Dia. = 1.613mm, for Propane Gas)
: Replace Label
: Instruction sheet

■ GAS VALVE FLOW

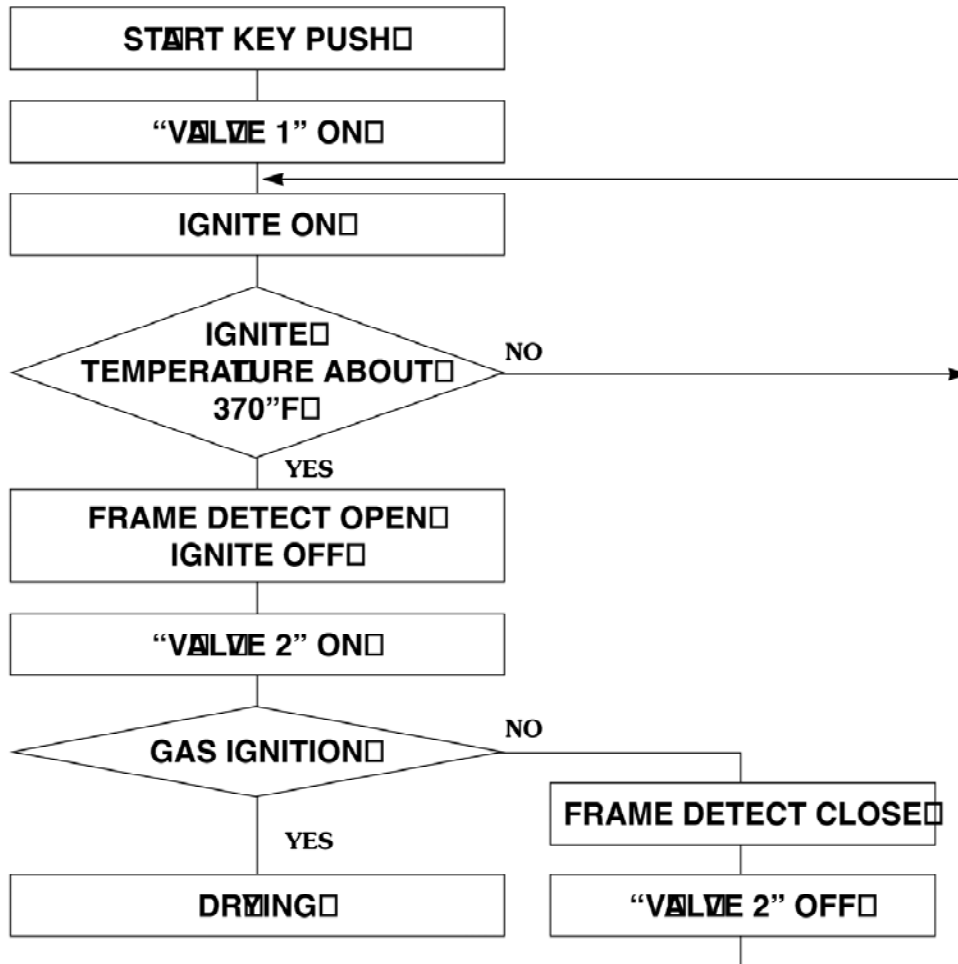

GAS IGNITION

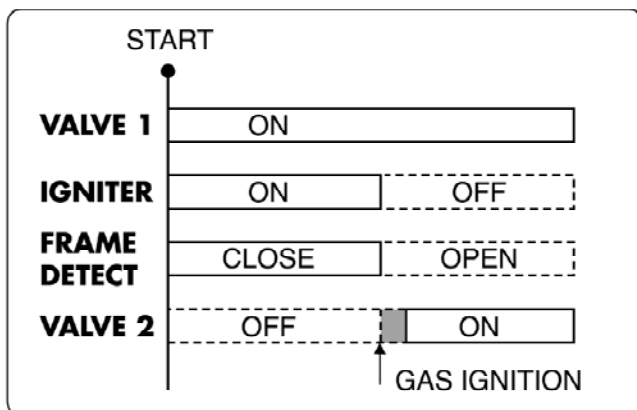

GAS VALVE STRUCTURE

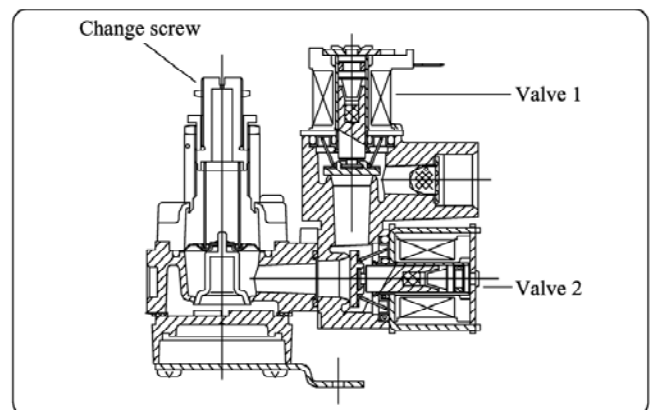

11

DISASSEMBLY INSTRUCTIONS

* Disassemble and repair the unit only after pulling out power plug from the outlet.

CONTROL PANEL ASSEMBLY

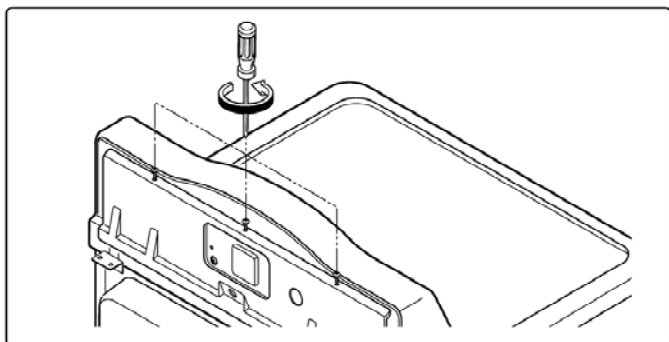

1. Remove 3 screws on the rear Panel.

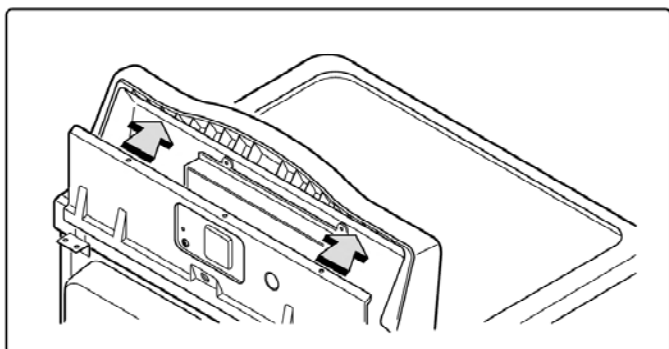

2. Pull the control panel forward.

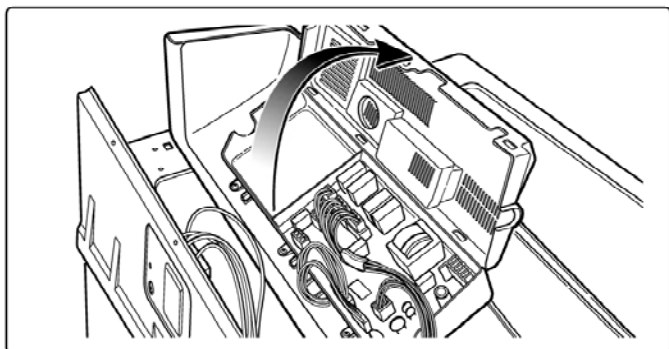

3. Open the cover protect.

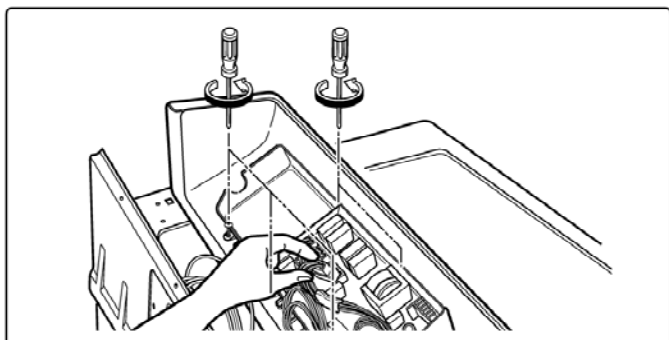

4. Disconnect connectors.

5. Remove 5 screws.

6. Disassemble the controller assembly.

TOP PLATE

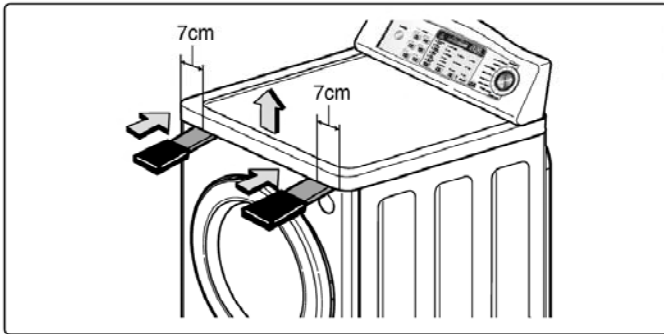

1. Push backward using an opener and lift the top plate.

COVER CABINET

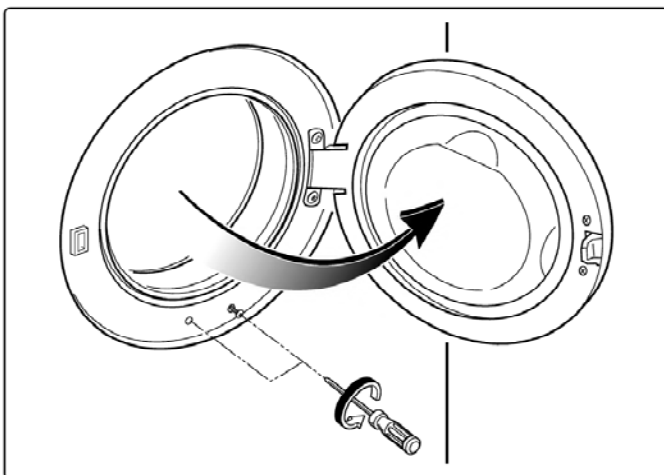

1. Open the top plate.
2. Open the door, Remove 2 screws.

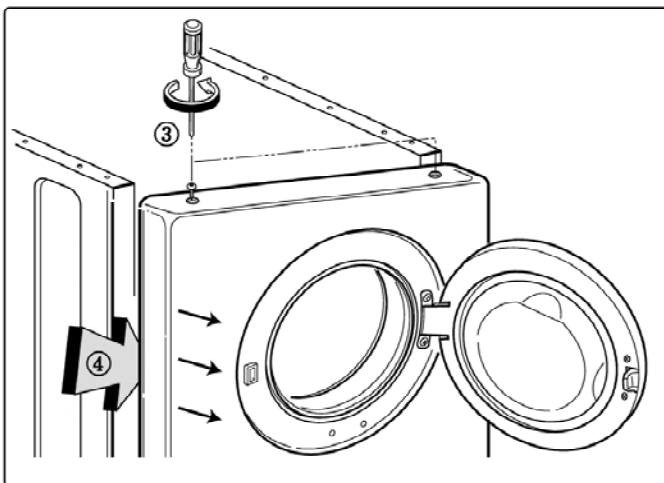

3. Remove 2 screws form upper side.
4. Pull the Cover Cabinet.
5. Disconnect the door switch connector.

TUB DRUM [FRONT]

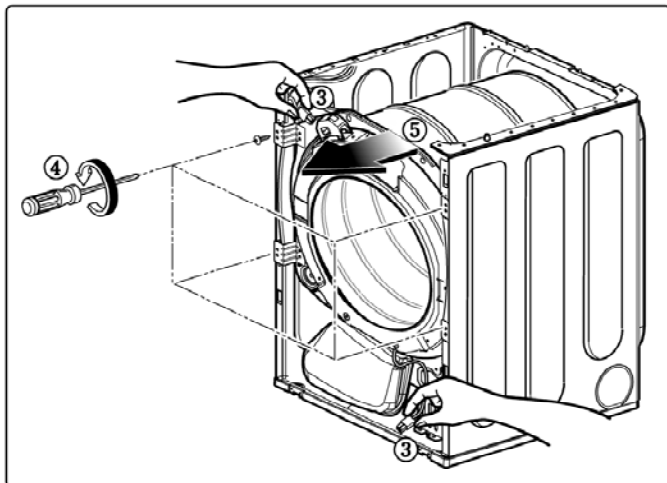

1. Open the top plate.
2. Remove Cover Cabinet.
3. Disconnect the door lamp and electro sensor connector.
4. Remove 4 screws.
5. Disassemble the Tub Drum [Front].

DRUM ASSEMBLY

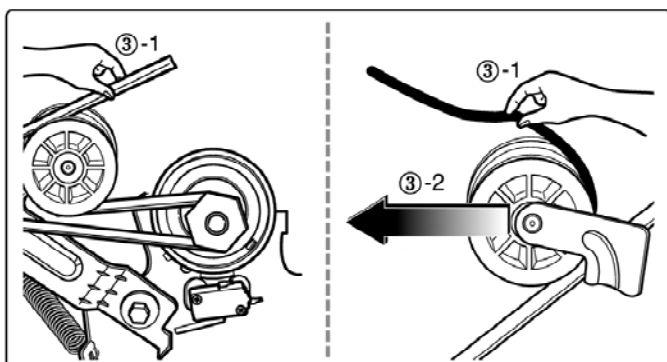

1. Open the top plate.
2. Remove the Cover Cabinet and Tub drum [front].
3. Disengage belt from motor and idler pulleys.
4. Carefully remove Drum out through front of dryer.

CHANGING THE DRUM LAMP

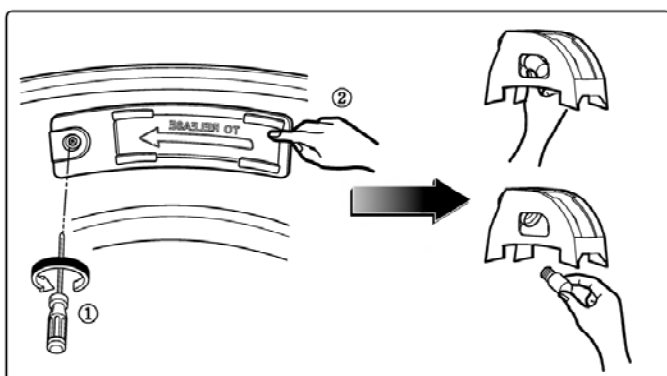

1. Open the door.
2. Remove the screw holding the drum lamp shield in place.
3. Slide the shield up and remove.
4. Remove the bulb and replace with a 15 watt, 120 volt candelabra-base bulb.
5. Replace the lamp shield and screw.

DRYER EXHAUST CHANGE

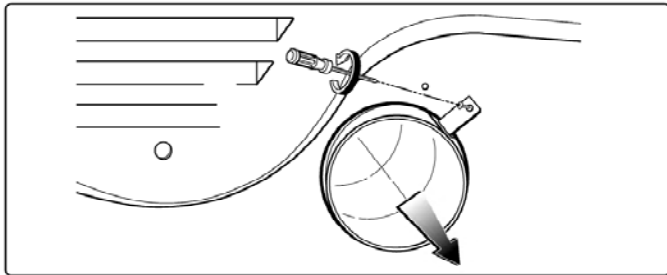

1. Remove screw & exhaust duct.

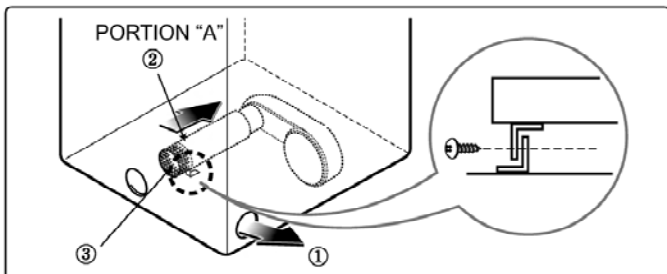

2. Detach and remove the bottom, left or right side knockout as desired.

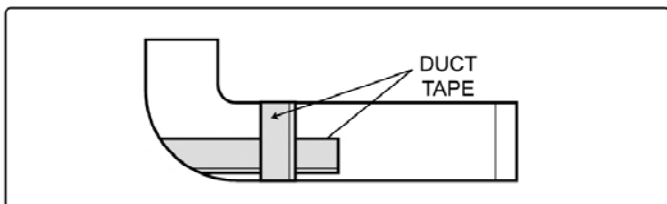

3. Reconnect the new duct [11 in (28cm)] to the blower housing, and attach the duct to the base.

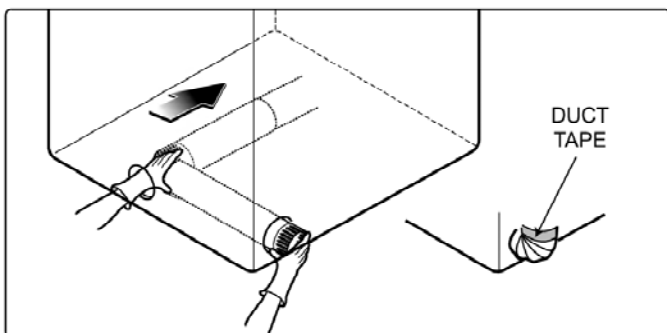

4. Pre-assemble 4" elbow with 4" duct. Wrap duct tape around joint.

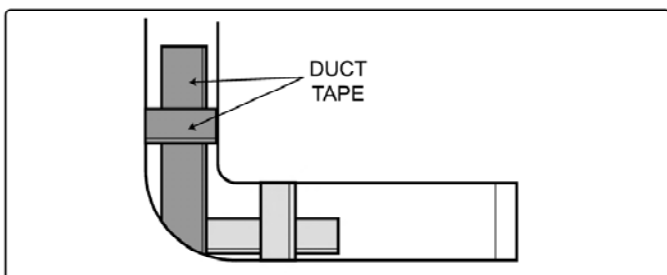

5. Insert duct assembly, elbow first, through the side opening and connect the elbow to the dryer internal duct.

FILTER ASSEMBLY

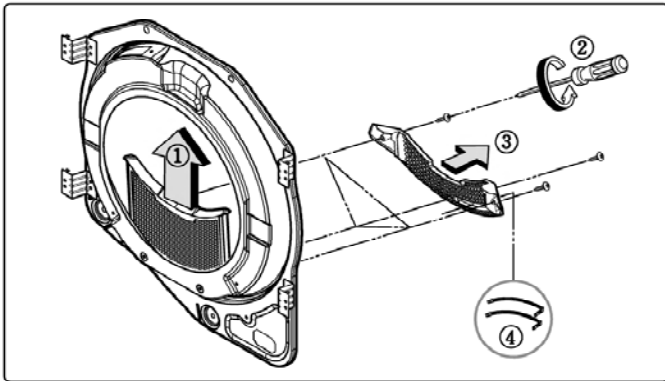

1. Remove the filter.
2. Remove 3 screws.
3. Pull the grill.
4. Disconnect electro sensor.

BLOWER HOUSING

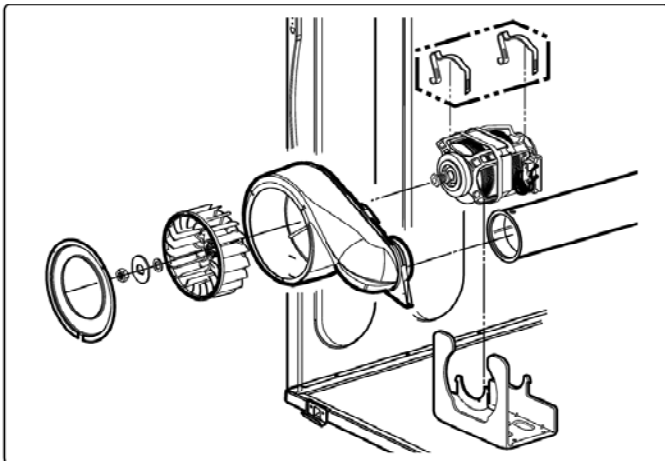

1. Open the top plate.
2. Remove the Cover Cabinet and Tub Drum [Front].
3. Remove the Drum assembly.
4. Remove 2 screws and cover(Air guide).
5. Remove the bolt and washer.
6. Pull the fan.
7. Disconnect the motor clamp and motor.

BACK COVER

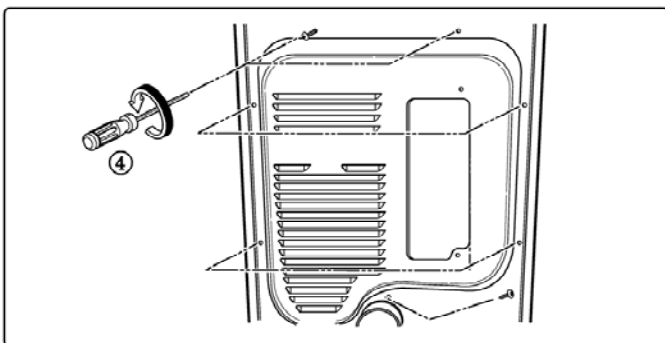

1. Open the top plate.
2. Remove the Cover Cabinet and Tub Drum [Front].
3. Remove the Drum assembly.
4. Remove 7 screws.
5. Pull the Tub Drum [Rear] towards the front.

AIR DUCT

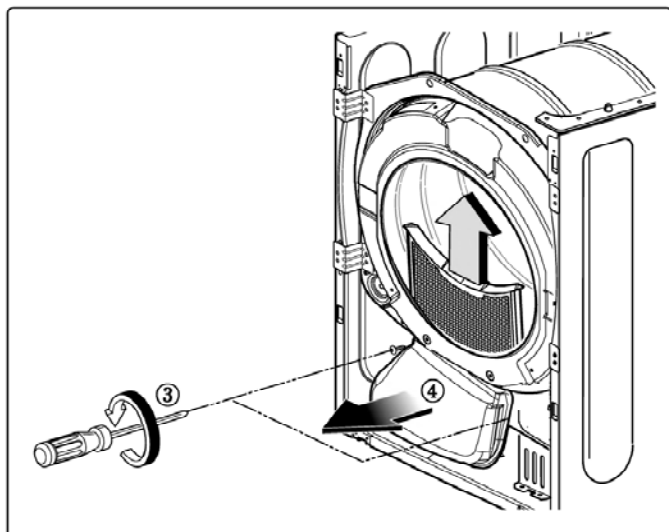

1. Open the top plate.
2. Remove the Cover Cabinet.
3. Remove filter and 2 screws.
4. Pull the air duct towards the front.

ROLLERS

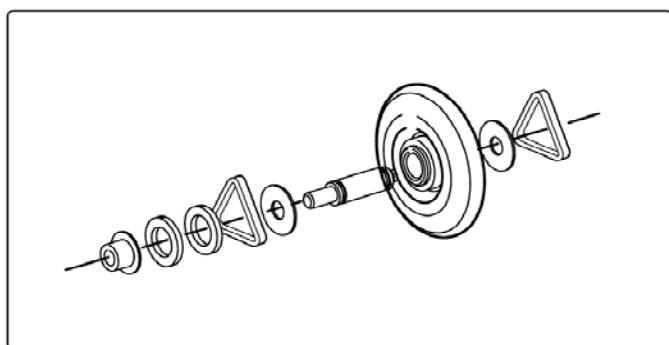

1. Open the top plate.
2. Remove the Cover Cabinet and Tub Drum [Front].
3. Remove the Drum assembly and Tub Drum [Rear].
4. Disconnect Air duct from the Tub Drum [Front].
5. Remove the roller from the Tub Drum [Front] and Tub Drum [Rear].

12

EXPLODED VIEW

12-1. Control Panel & Plate Assembly

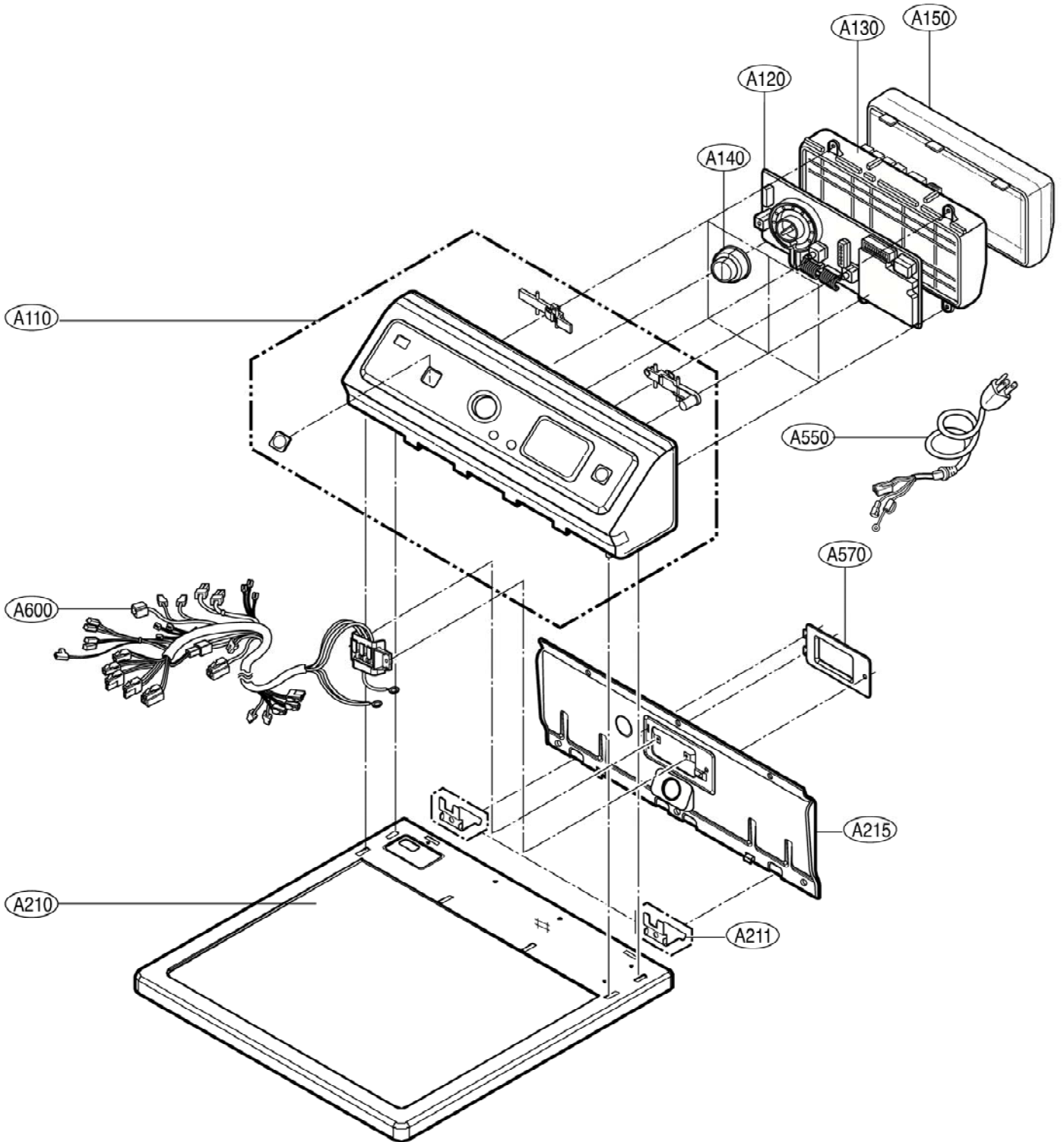

12-2. Cabinet & Door Assembly

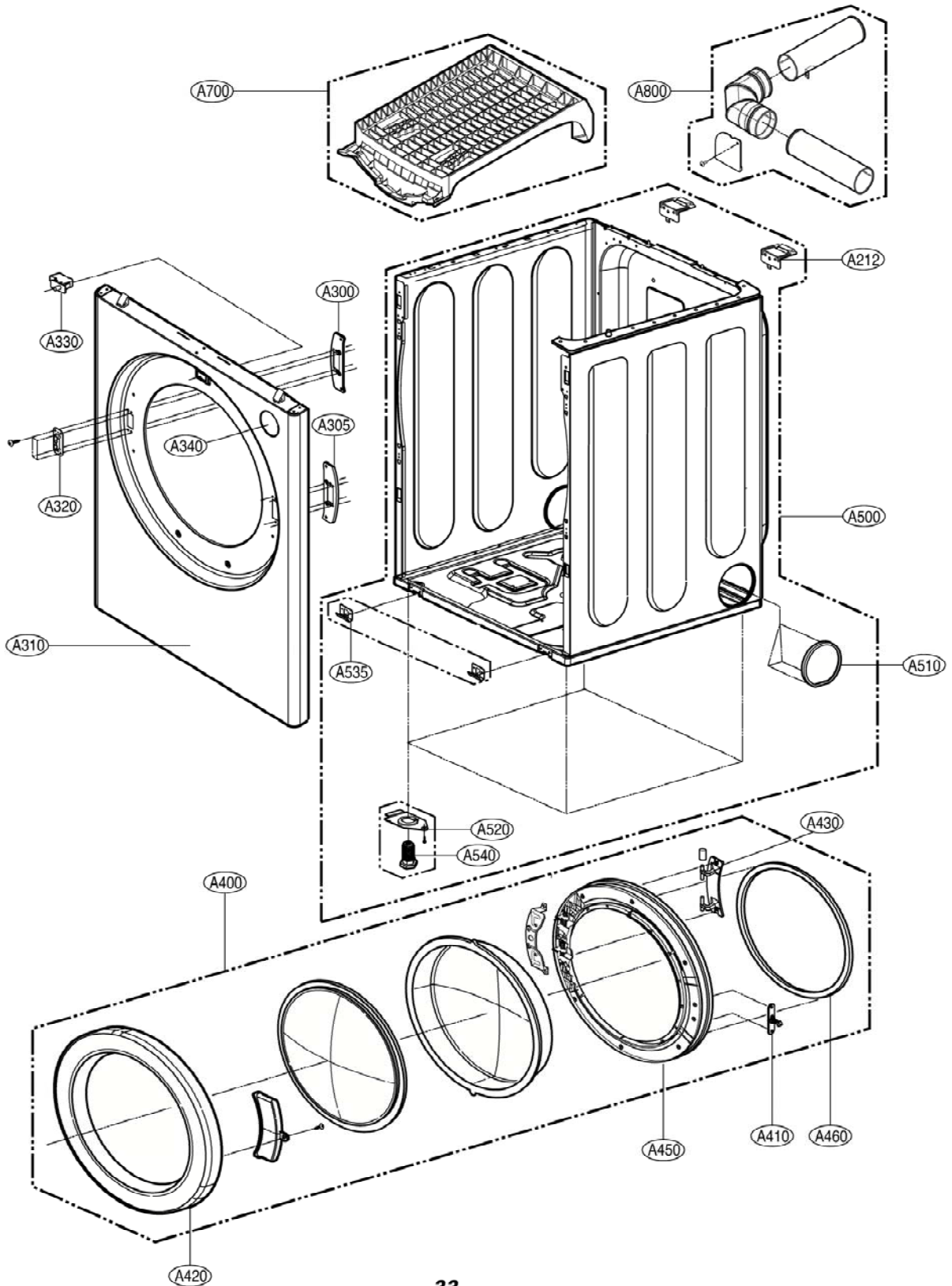

12-3-1. Drum & Motor Assembly : Electric Type

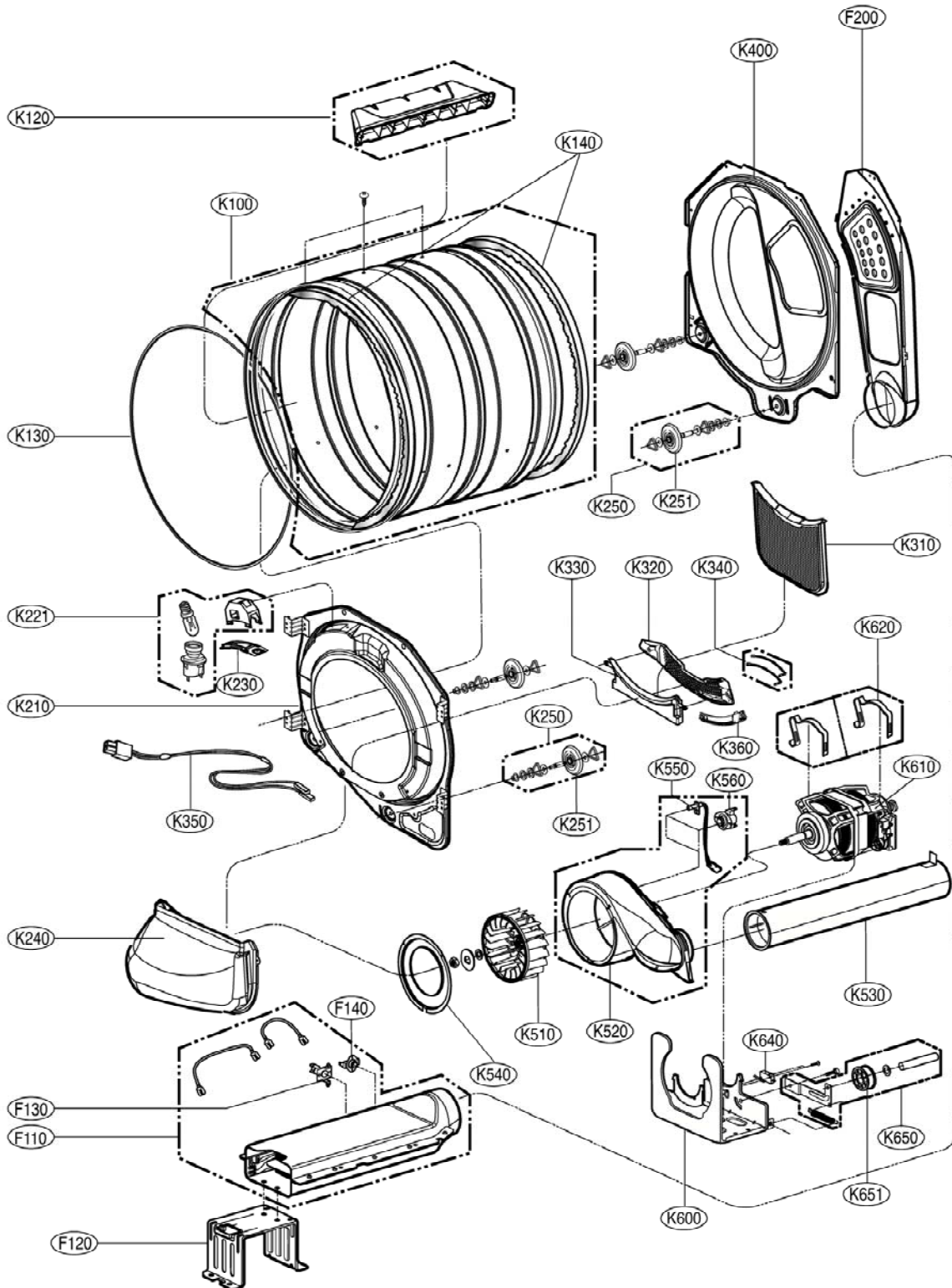

12-3-2. Drum & Motor Assembly : Gas type

