

BRINKMANN®

**PROFESSIONAL STAINLESS STEEL
CHARCOAL GRILL
PARRILLA A CARBÓN PROFESIONAL DE
ACERO INOXIDABLE**

OWNER'S MANUAL / MANUAL DEL PROPIETARIO

**ASSEMBLY AND OPERATING INSTRUCTIONS
INSTRUCCIONES DE ENSAMBLAJE Y OPERACIÓN**

⚠ WARNING

READ AND FOLLOW ALL WARNINGS AND INSTRUCTIONS IN THIS MANUAL TO AVOID PERSONAL INJURY OR PROPERTY DAMAGE.

⚠ ADVERTENCIA

PARA EVITAR LESIONES PERSONALES Y DAÑOS MATERIALES LEA Y OBEDEZCA TODAS LAS ADVERTENCIAS E INSTRUCCIONES QUE APARECEN EN ESTE MANUAL



IMPORTANT SAFETY WARNINGS

WE WANT YOU TO ASSEMBLE AND USE YOUR GRILL AS SAFELY AS POSSIBLE.

THE PURPOSE OF THIS SAFETY ALERT SYMBOL 

IS TO ATTRACT YOUR ATTENTION TO POSSIBLE HAZARDS AS YOU ASSEMBLE AND USE YOUR GRILL.

WHEN YOU SEE THE SAFETY ALERT SYMBOL, PAY CLOSE ATTENTION TO THE INFORMATION WHICH FOLLOWS!

** READ ALL SAFETY WARNINGS AND INSTRUCTIONS CAREFULLY
BEFORE ASSEMBLING AND OPERATING YOUR GRILL.**

WARNING

- Only use this grill on a hard, level, non-combustible, stable surface (concrete, ground, etc.) capable of supporting the weight of the grill. Never use on wooden or other surfaces that could burn.
 - DO NOT use grill without charcoal ash tray in place. DO NOT attempt to remove charcoal ash tray while tray contains hot coals.
 - Proper clearance of 10 feet between the grill and combustible material (bushes, trees, wooden decks, fences, buildings, etc.) or construction should be maintained at all times when grill is in use. Do not place grill under a roof overhang or other enclosed area.
 - For outdoor use only. Do not operate grill indoors or in an enclosed area.
 - For household use only. Do not use this grill for other than its intended purpose.
 - We recommend the use of a Charcoal Chimney Starter to avoid the dangers associated with charcoal lighting fluid. If you choose to use charcoal lighting fluid, only use lighting fluid approved for lighting charcoal. Carefully read manufacturer's warnings and instructions on the charcoal lighting fluid and charcoal prior to the use of their product. Store charcoal lighting fluid safely away from grill.
 - When using charcoal lighting fluid, allow charcoal to burn with grill lid open until covered with a light ash (approximately 20 minutes). This will allow charcoal lighting fluid to burn off. Failure to do this could trap fumes from charcoal lighting fluid in grill and may result in a flash fire or explosion when lid is opened.
 - Never use charcoal that has been pre-treated with lighter fluid. Use only a high grade plain charcoal or charcoal/wood mixture.
 - Do not use gasoline, kerosene or alcohol for lighting charcoal. Use of any of these or similar products could cause an explosion possibly leading to severe bodily injury.
 - Never add charcoal lighting fluid to hot or even warm coals as flashback may occur causing severe burns.
 - Place grill in an area where children and pets cannot come into contact with unit. Close supervision is necessary when grill is in use.
 - Do not leave grill unattended when in use.
 - When adding charcoal and/or wood, use extreme caution and follow instructions in "Adding Charcoal/Wood During Cooking" section of this manual.
 - Do not store or use grill near gasoline or other flammable liquids, gases or where flammable vapors may be present.
 - Use caution when adjusting charcoal grate height. Handle may be hot when in use.
- Grill is hot when in use. To avoid burns:
- DO NOT attempt to move the grill.
 - Lock the casters so the unit does not accidentally move.
 - Wear protective gloves or oven mitts when adjusting door handle, ash tray, cooking height or air vents.
 - DO NOT touch any hot grill surfaces.
 - DO NOT wear loose clothing or allow hair to come in contact with grill.

⚠ WARNING

- When grilling, grease from meat may drip into the charcoal and cause a grease fire. If this should happen close lid to suffocate the flame. Do not use water to extinguish grease fires.
- Use caution since flames can flare-up when fresh air suddenly comes in contact with fire. When opening the lid, keep hands, face and body a safe distance from hot steam and flame flare-ups.
- Never place more than 15 pounds on side tables. Do not lean on the side tables.
- Do not exceed a temperature of 400°F. Do not allow charcoal and/or wood to rest on the walls of grill. Doing so will greatly reduce the life of the metal and finish of your grill.
- Use caution when assembling and operating your grill to avoid scrapes or cuts from sharp edges of metal parts. Use caution when reaching into or under grill.
- When opening lid, make sure it is pushed all the way open. If lid is not fully open, it could fall back to a closed position and cause bodily injury.
- In windy weather, place grill in an outdoor area that is protected from the wind.
- Close lid to suffocate flame.
- Never leave coals and ashes in grill unattended. Before grill can be left unattended, remaining coals and ashes must be removed from grill. Use caution to protect yourself and property. Carefully place remaining coals and ashes in a non-combustible metal container and saturate completely with water. Allow coals and water to remain in metal container 24 hours prior to disposing.
- Extinguished coals and ashes should be placed a safe distance from all structures and combustible materials.
- With a garden hose, completely wet the surface beneath and around grill to extinguish any ashes, coals or embers which may have fallen during the cooking or cleaning process.
- After each use, clean the grill thoroughly and reapply a light coat of oil to interior to prevent rusting. Cover the grill to protect it from excessive rusting.
- Use caution when lifting or moving grill to prevent strains and back injuries.
- We advise that a fire extinguisher be on hand. Refer to your local authority to determine proper size and type of fire extinguisher.
- Accessory attachments not manufactured by The Brinkmann Corporation for this particular product are not recommended and may lead to personal injury or property damage.
- Store the grill out of reach of children and in a dry location when not in use.
- Do not attempt to service grill other than normal maintenance as explained in "After-Use Safety" and "Proper Care & Maintenance" sections of this manual. Repairs should be performed by The Brinkmann Corporation only.
- Properly dispose of all packaging material.

USE CAUTION AND COMMON SENSE WHEN OPERATING YOUR GRILL.

**FAILURE TO ADHERE TO SAFETY WARNING AND GUIDELINES IN THIS MANUAL COULD RESULT
IN BODILY INJURY OR PROPERTY DAMAGE.**

SAVE THIS MANUAL FOR FUTURE REFERENCE.

ASSEMBLY INSTRUCTIONS

▲ READ ALL SAFETY WARNINGS & ASSEMBLY INSTRUCTIONS CAREFULLY BEFORE ASSEMBLING OR OPERATING YOUR GRILL.

FOR MISSING PARTS, PLEASE CALL CUSTOMER SERVICE AT 800-527-0717.

(Proof of purchase will be required.)

Inspect contents of the box to ensure all parts are included and undamaged.

We recommend two people work together when assembling this unit.

The estimated time of assembly for this grill is approximately 30 minutes.

The following tools are required to assemble this Professional Stainless Steel Charcoal Grill:

- Pliers
- Phillips & Flathead Screwdrivers
- Adjustable Wrench

PARTS LIST - PROFESSIONAL GRILL:

- ① 1 Temperature Gauge
- ② 1 Handle
- ③ 2 Handle Stands
- ④ 1 Lid
- ⑤ 3 Cooking Grills
- ⑥ 2 Side Shelves
- ⑦ 4 Legs
- ⑧ 1 Lower Grill Housing
- ⑨ 1 Crank
- ⑩ 1 Bottom Shelf
- ⑪ 2 Air Vents
- ⑫ 1 Charcoal Ash Tray
- ⑬ 4 Steel Casters

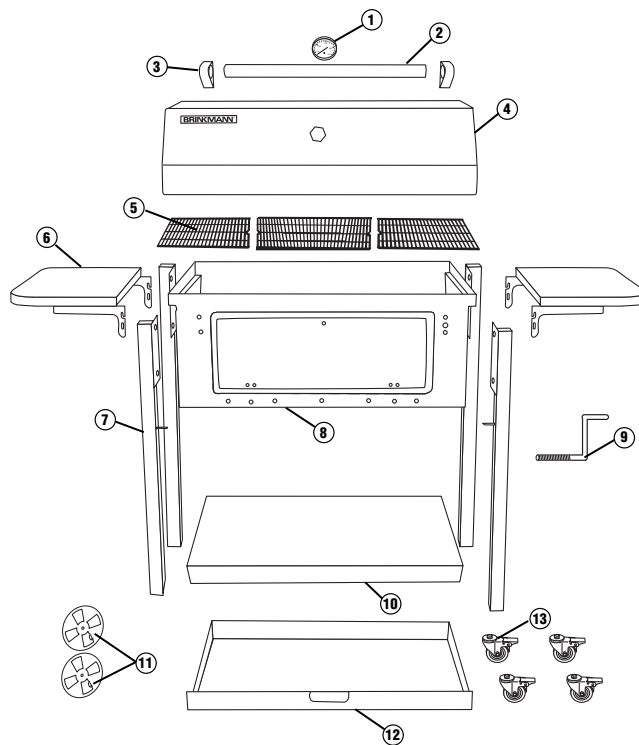

FOR COVERS, ACCESSORIES AND OTHER PRODUCTS, PLEASE VISIT US ONLINE AT:

www.brinkmann.net

FOR GRILL WARRANTY REPLACEMENT PARTS, PLEASE VISIT US AT:

www.grillpartsonline.com

Parts Bag Contents

- ① 1 10 X 8mm hexagonal nut
- ② 1 Door locking plate
- ③ 1 Door handle
- ④ 6 6 X 5mm hexagonal nuts
- ⑤ 4 6 X 45mm Phillips head bolts
- ⑥ 14 6 X 12mm Phillips head bolts
- ⑦ 2 Cotter pins
- ⑧ 2 Hood pivot pins

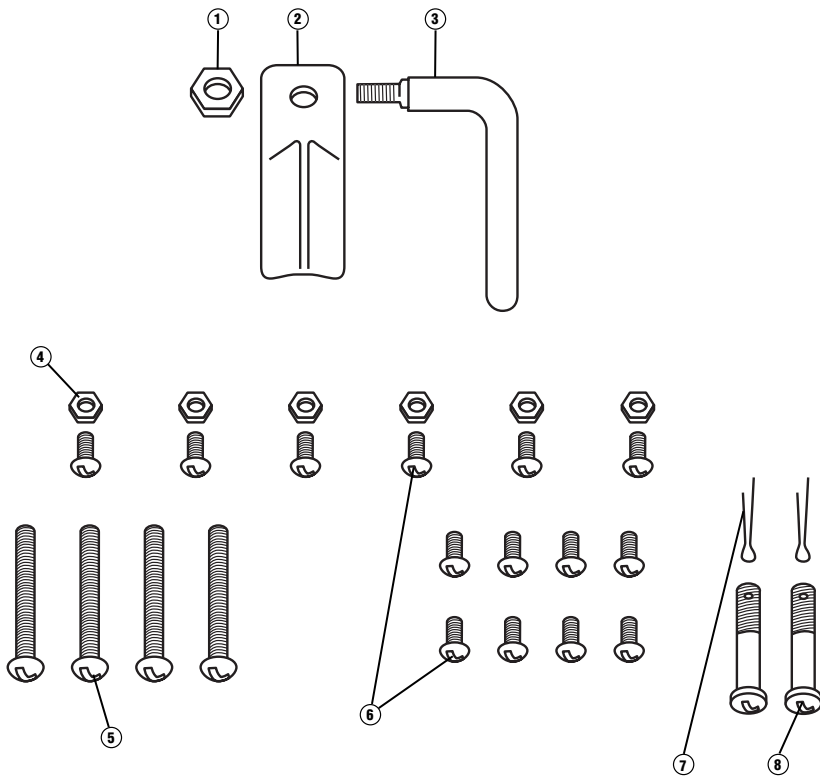

Choose a good, cleared assembly area and get a friend to help you put your grill together. Lay cardboard down to protect grill finish and assembly area. Turn the grill on its side to begin assembly.

Step 1

Insert door handle through hole in door with handle pointing down. Place door locking plate over door handle pointing up and secure with a 10 X 8mm hexagonal nut.

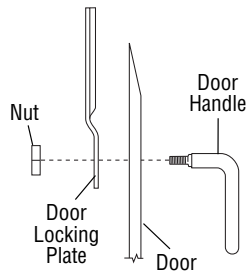

Step 2

Attach steel casters to bottom of each leg. Tighten caster bolts securely.

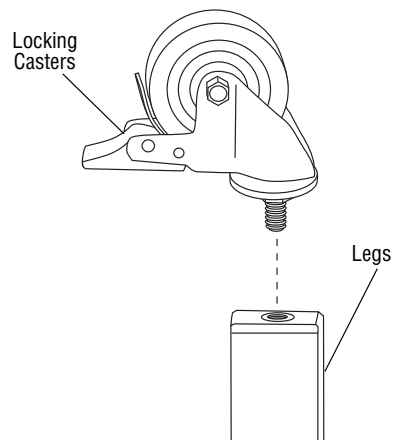

Step 3

Align the holes in one leg bracket with the holes in the body of the grill. Insert two 6 X 12mm Phillips head bolts through the leg bracket and secure to the grill body.

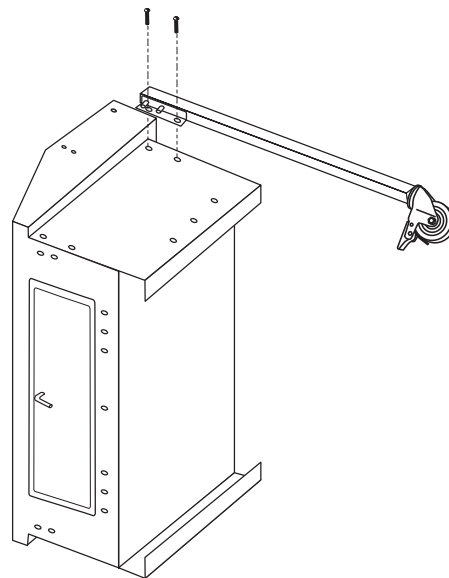

Step 4

Hang a shelf onto the lower stud of the leg that you have attached to the grill body.

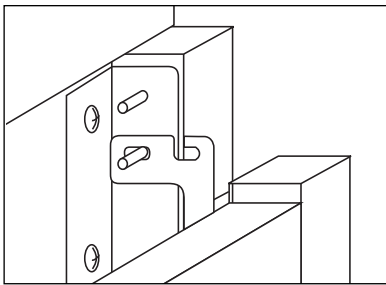

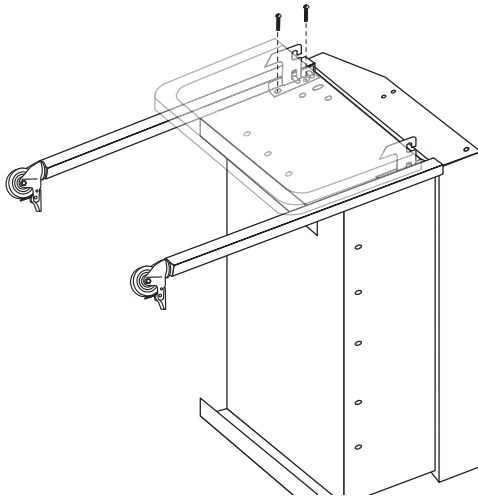

Step 5

Insert the lower stud of the opposite leg bracket into the opposite side of the shelf. Align the holes in the leg bracket with the holes in the grill body. Insert two 6 X 12mm Phillips head bolts through the leg bracket and secure to the grill body.

Step 6

With the help of a friend, turn grill onto opposite side. Try to minimize stress on the legs and shelf. Repeat steps 2 through 5.

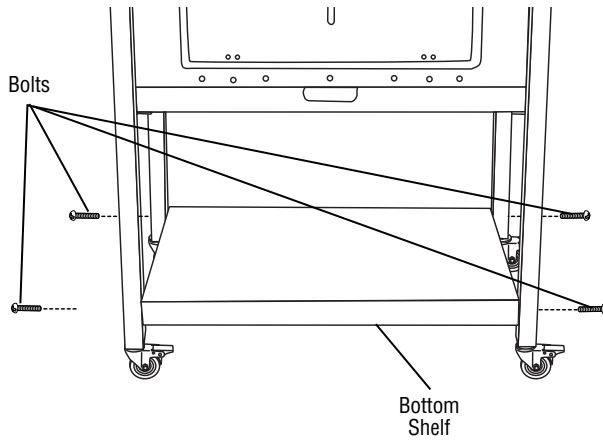

Step 7

With the help of a friend, set the unit upright. Try to minimize stress on the legs of the grill.

Step 8

Have a friend help you align holes in bottom shelf with screw holes in legs. Insert four 6 X 45mm Phillips head bolts through the legs and secure to the bottom shelf.

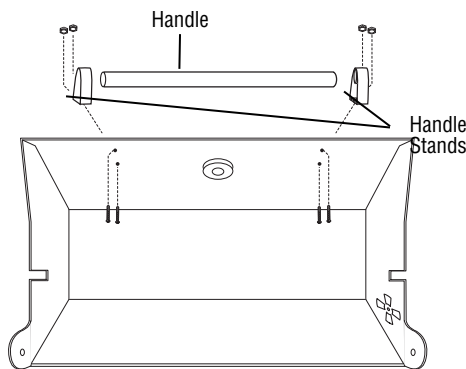

Step 9

Attach one handle stand using two 6 X 12mm Phillips head bolts and two 6 X 5mm hexagonal nuts. Next insert hood handle into handle stand. Place the other handle stand over handle and attach by using two 6 X 12mm Phillips head bolts and two 6 X 5mm hexagonal nuts.

Step 10

Rest lid on the body and align hinge holes, then thread hood pivot pins through hood and into grill body. Insert cotter pins into hood pivot pins and bend ends out slightly.

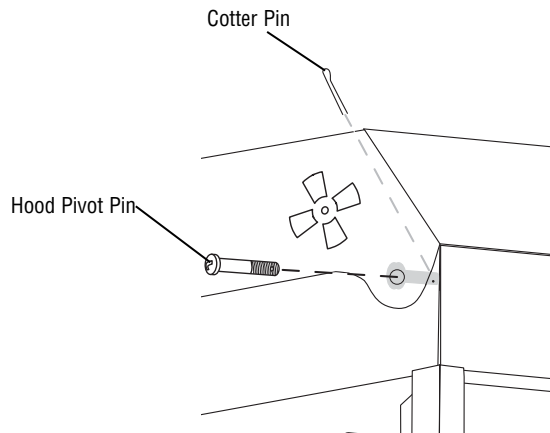

Step 11

Attach two air vent covers to the inside of lid and body. Place air vent cover on the inside of the unit with the adjustment tab sticking through one of the air vent holes. Using 6 x 12mm screw and nut, secure vent cover to the unit. Do not overtighten the nut as this will make the vent difficult to open and close.

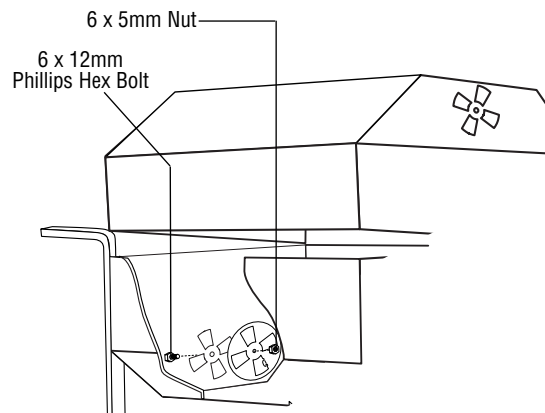

Step 12

Insert crank through front of grill body and into crank bracket. Rotate clockwise until crank engages charcoal grate.

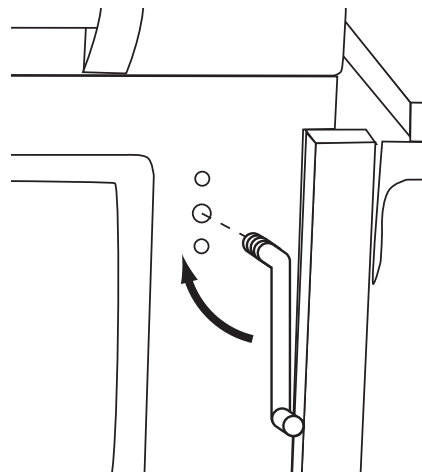

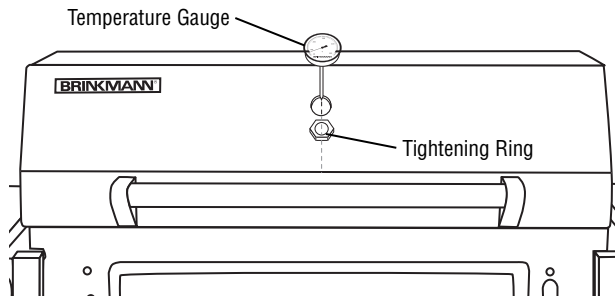

Step 13

Remove tightening ring from temperature gauge. Insert temperature gauge through the opening on front of lid, re-thread tightening ring.

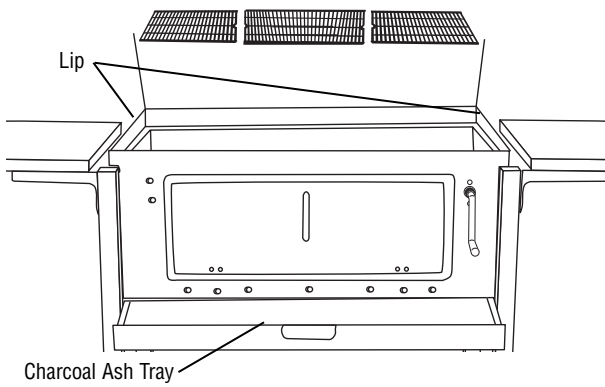

Step 14

Place cooking grills on lip of body.

Step 15

Slide charcoal ash tray into guides at bottom of grill body.

WARNING: DO NOT use grill without charcoal ash tray in place. DO NOT attempt to remove charcoal ash tray while tray contains hot coals.

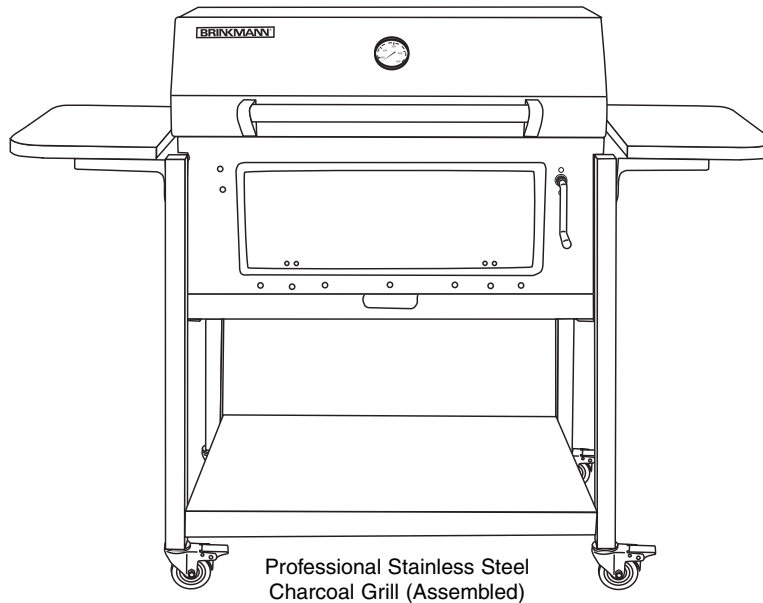

PREPARATION FOR USE & LIGHTING INSTRUCTIONS

⚠ PLACE THE GRILL OUTDOORS ON A HARD, LEVEL, NON-COMBUSTIBLE SURFACE AWAY FROM ROOF OVERHANG OR ANY COMBUSTIBLE MATERIAL. NEVER USE ON WOODEN OR OTHER SURFACES THAT COULD BURN. PLACE THE GRILL AWAY FROM OPEN WINDOWS OR DOORS TO PREVENT SMOKE FROM ENTERING YOUR HOUSE. IN WINDY WEATHER, PLACE THE GRILL IN AN OUTDOOR AREA THAT IS PROTECTED FROM THE WIND.

⚠ READ ALL SAFETY WARNINGS AND INSTRUCTIONS CAREFULLY BEFORE OPERATING YOUR GRILL.

Curing Your Grill

Prior to your first use of the Brinkmann Professional Stainless Steel Charcoal Grill, follow the instructions below carefully to cure your grill. Curing your grill will minimize damage to the exterior finish as well as rid the grill of paint odor that can impart unnatural flavors to the first meal prepared on your Brinkmann Professional Stainless Steel Charcoal Grill.

IMPORTANT: To protect your grill from excessive rust, the unit must be properly cured and covered at all times when not in use. A cover for your Professional Stainless Steel Charcoal Grill may be ordered directly from Brinkmann by calling 800-468-5252.

Step 1

Lightly coat all interior surfaces of the Professional Stainless Steel Charcoal Grill including cooking grill with vegetable oil or vegetable oil spray. Do not coat charcoal grate or charcoal tray.

Step 2

Follow the instructions below carefully to build a fire. You may use charcoal and/or wood as fuel in the Professional Stainless Steel Charcoal Grill (see "Adding Charcoal/Wood During Cooking" section of this manual).



WARNING: Never use charcoal that has been pre-treated with lighter fluid. Use only a high grade plain charcoal or charcoal/wood mixture.



If using a Charcoal Chimney Starter, follow all manufacturer's warnings and instructions regarding the use of their product. Start with 8 to 10 pounds of charcoal. This should be enough charcoal to cook with, once the curing process has been completed. When charcoal is burning strong, carefully place hot coals in center of charcoal grate.

WARNING: DO NOT use grill without charcoal ash tray in place. DO NOT attempt to remove charcoal ash tray while tray contains hot coals.

NOTE: To extend the life of your grill, make sure that hot coals and wood do not touch the walls of grill.

IF USING CHARCOAL CHIMNEY STARTER, PROCEED TO STEP 5

If you choose to use charcoal lighting fluid, ONLY use charcoal lighting fluid approved for lighting charcoal. Do not use gasoline, kerosene, alcohol or other flammable material for lighting charcoal. Follow all manufacturer's warnings and instructions regarding the use of their product. Start with 8 to 10 pounds of charcoal. This should be enough charcoal to cook with, once the curing process has been completed. Place the charcoal in center of charcoal grate.

Step 3

Saturate charcoal with lighting fluid. With lid open wait 2 to 3 minutes to allow lighting fluid to soak into charcoal. Store charcoal lighting fluid safely away from the grill.

Step 4

With grill lid and door open, stand back and carefully light charcoal through the door. Allow to burn until covered with a light ash (approximately 20 minutes).

WARNING: Charcoal lighting fluid must be allowed to completely burn off prior to closing grill lid (approximately 20 minutes). Failure to do this could trap fumes from charcoal lighting fluid in grill and may result in a flash-fire or explosion when lid is opened.

WARNING: Wear protective gloves or oven mitts when adjusting door handle, ash tray, cooking height or air vents.

Step 5

With coals burning strong, close the lid and door. Allow the temperature to reach 225°F on the heat indicator. Maintain this temperature for 2 hours.

Step 6

Increase the temperature to 400°F on the heat indicator. This can be achieved by adding more charcoal and/or wood (see "Adding Charcoal/Wood During Cooking" section of this manual) and/or adjusting the air vents. Maintain this temperature for 1 hour then allow unit to cool completely.

NOTE: It is important that the exterior of the grill is not scraped or rubbed during the curing process.

IMPORTANT: To protect your smoker from excessive rust, the unit must be cured periodically and covered at all times when not in use. A smoker cover can be ordered directly from Brinkmann by calling 800-468-5252.

YOUR BRINKMANN PROFESSIONAL GRILL IS NOW CURED AND READY FOR USE.



OPERATING INSTRUCTIONS

⚠ PLACE THE GRILL OUTDOORS ON A HARD, LEVEL, NON-COMBUSTIBLE SURFACE AWAY FROM ROOF OVERHANG OR ANY COMBUSTIBLE MATERIAL. NEVER USE ON WOODEN OR OTHER SURFACES THAT COULD BURN. PLACE THE GRILL AWAY FROM OPEN WINDOWS OR DOORS TO PREVENT SMOKE FROM ENTERING YOUR HOUSE. IN WINDY WEATHER, PLACE THE GRILL IN AN OUTDOOR AREA THAT IS PROTECTED FROM THE WIND.

⚠ READ ALL SAFETY WARNINGS AND INSTRUCTIONS CAREFULLY BEFORE OPERATING YOUR GRILL.

Smoking

Step 1

Follow instructions below carefully to build a fire. You may use charcoal and/or wood as fuel in the Professional Stainless Steel Charcoal Grill (see "Adding Charcoal/Wood During Cooking" section of this manual).



WARNING: Never use charcoal that has been pre-treated with lighter fluid. Use only a high grade plain charcoal or charcoal/wood mixture.

If using a Charcoal Chimney Starter, follow all manufacturer's warnings and instructions regarding the use of their product. Carefully place 5 to 6 pounds of hot coals on left side of charcoal grate.



WARNING: DO NOT use grill without charcoal ash tray in place. DO NOT attempt to remove charcoal ash tray while tray contains hot coals.

NOTE: To extend the life of your grill, make sure that hot coals and wood do not touch the walls of grill or lay inside of cooking chamber under charcoal tray.

IF USING CHARCOAL CHIMNEY STARTER, PROCEED TO STEP 5

If you choose to use charcoal lighting fluid, ONLY use charcoal lighting fluid approved for lighting charcoal. Do not use gasoline, kerosene, alcohol or other flammable material for lighting charcoal. Follow all manufacturer's warnings and instructions regarding the use of their product. Place 5 to 6 pounds of charcoal on left side of charcoal grate.

Step 2

Saturate charcoal with lighting fluid. With lid open wait 2 to 3 minutes to allow lighting fluid to soak into charcoal. Store charcoal lighting fluid safely away from the grill.

Step 3

With grill lid and door open, stand back and carefully light charcoal and allow to burn until covered with a light ash (approximately 20 minutes). Charcoal lighting fluid must be allowed to completely burn off prior to closing grill lid.



WARNING: Failure to do this could trap fumes from charcoal lighting fluid in grill and may result in a flash-fire or explosion when lid is opened.

Step 4

With coals burning well, carefully add wood chunks using long cooking tongs (see “Flavoring Wood” and “Adding Charcoal/Wood During Cooking” sections of this manual.)

Step 5

Place cooking grills on grill support lips. Use charcoal grate adjuster crank to position charcoal grate to lowest level.

WARNING: Wear protective gloves or oven mitts when adjusting door handle, ash tray, cooking height or air vents.

Step 6

Place food on right side of cooking grill and close lid.

Step 7

The ideal smoking temperature is between 175°F and 250°F. For large cuts of meat, allow approximately one hour of cooking time per pound of meat. **Always use a meat thermometer to ensure food is fully cooked before removing from grill.**

Step 8

Allow grill to cool completely, then follow instructions in the “After-Use Safety” and “Proper Care & Maintenance” sections of this manual.

During the smoking process, avoid the temptation to open lid to check food. Opening the lid allows heat and smoke to escape, making additional cooking time necessary.

Food closest to the charcoal will cook and brown faster. Rotate food midway through the cooking cycle. If food is excessively browned or flavored with smoke, wrap food in aluminum foil after the first few hours of smoking. This will allow food to continue cooking without further browning or smoke flavoring.

When cooking fish or extra lean cuts of meat, you may want to try water smoking to keep the food moist. Before starting a fire, place charcoal tray to lowest level. Use a flat bottom metal pan shallow enough to fit between charcoal grate and cooking grill as a water pan. Set the metal pan on charcoal grate under food and cooking grill. Fill with water or marinade until 2/3 full. **Build your fire on the opposite side of water pan.**

CAUTION: Always use oven mitts/gloves to protect your hands. Liquid in water pan will be extremely hot and can scald or burn. Always allow liquid to cool completely before handling. Do not allow liquid to completely evaporate from water pan.

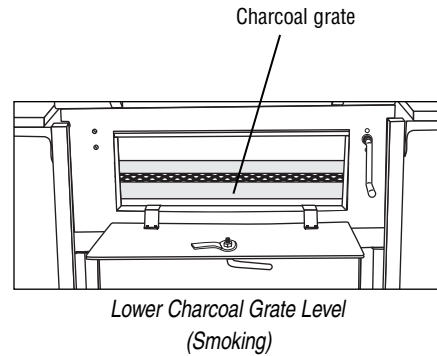

Smoke Cooking Tips

Grilling/Searing

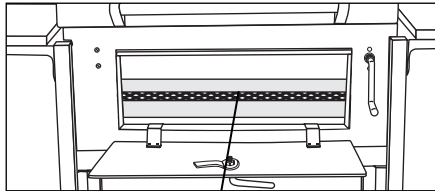

Charcoal grate

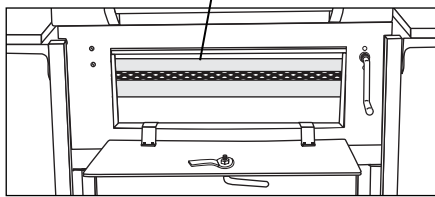

Middle Low/Middle High Charcoal Tray Level
(Grilling)

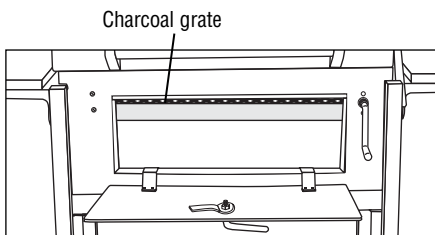

High Charcoal Tray Level
(Searing)

Step 1

Lightly coat all interior surfaces of the Professional Stainless Steel Charcoal Grill including cooking grill with vegetable oil or vegetable oil spray. Do not coat charcoal grate or charcoal ash tray.

Step 2

Follow the instructions below carefully to build a fire. You may use charcoal and/or wood as fuel in the Professional Stainless Steel Charcoal Grill (see "Adding Charcoal/Wood During Cooking" section of this manual).



WARNING: Never use charcoal that has been pre-treated with lighter fluid. Use only a high grade plain charcoal or charcoal/wood mixture.

If using a Charcoal Chimney Starter, follow all manufacturer's warnings and instructions regarding the use of their product. Start with 8 to 10 pounds of charcoal. This should be enough charcoal to cook with, once the curing process has been completed. When charcoal is burning strong, carefully place hot coals in center of charcoal grate.



WARNING: DO NOT use grill without charcoal ash tray in place. DO NOT attempt to remove charcoal ash tray while tray contains hot coals.

NOTE: To extend the life of your grill, make sure that hot coals and wood do not touch the walls of grill.

IF USING CHARCOAL CHIMNEY STARTER, PROCEED TO STEP 5

If you choose to use charcoal lighting fluid, ONLY use charcoal lighting fluid approved for lighting charcoal. Do not use gasoline, kerosene, alcohol or other flammable material for lighting charcoal. Follow all manufacturer's warnings and instructions regarding the use of their product. Start with 8 to 10 pounds of charcoal. This should be enough charcoal to cook with, once the curing process has been completed. Place the charcoal in center of charcoal grate.

Step 3

Saturate charcoal with lighting fluid. With lid open wait 2 to 3 minutes to allow lighting fluid to soak into charcoal. Store charcoal lighting fluid safely away from the grill.

Step 4

With grill lid open, stand back and carefully light charcoal and allow to burn until covered with a light ash (approximately 20 minutes).



WARNING: Charcoal lighting fluid must be allowed to completely burn off prior to closing grill lid (approximately 20 minutes). Failure to do this could trap fumes from charcoal lighting fluid in grill and may result in a flash-fire or explosion when lid is opened.

Step 5

Place cooking grill on grill support lips. Use charcoal grate adjuster crank to position charcoal grate to desired cooking level.

WARNING: Wear protective gloves or oven mitts when adjusting door handle, ash tray, cooking height or air vents.

Step 6

Place food on cooking grill and close grill lid. **Always use a meat thermometer to ensure food is fully cooked before removing from grill.**

Step 7

Allow grill to cool completely, then follow instructions in the "After-Use Safety" and "Proper Care & Maintenance" sections of this manual.

To obtain your favorite smoke flavor, experiment by using chunks, sticks or chips of flavor producing wood such as hickory, pecan, apple, cherry, or mesquite. Most fruit or nut tree wood may be used for smoke flavoring. Do not use resinous wood such as pine as it will produce an unpleasant taste.

Wood chunks or sticks 3" to 4" long and 1" to 2" thick work best. Unless the wood is still green, soak the wood in water for 30 minutes or wrap each piece in foil and tear several small holes in the foil to produce more smoke and prevent the wood from burning too quickly. A lot of wood is not required to obtain a good smoke flavor. A recommended amount for the Professional Stainless Steel Charcoal Grill is 5 to 6 wood chunks or sticks. Experiment by using more wood for stronger smoke flavor or less wood for milder smoke flavor.

Additional flavoring wood should not have to be added during the cooking process. However, it may be necessary when cooking very large pieces of food. Follow instructions and cautions in the "Adding Charcoal/Wood During Cooking" section of this manual to avoid injury while adding wood.

Flavoring Wood



Regulating Heat

To increase heat, more wood and/or charcoal may be needed or an adjustment to the air vents may be necessary. Follow instructions in “Adding Charcoal/Wood During Cooking” section of this manual.

To maintain the temperature, more wood and/or charcoal may need to be added or an adjustment to the air vents may be necessary during the cooking cycle.

NOTE: Dry wood burns hotter than charcoal, so you may want to increase the ratio of wood to charcoal to increase the cooking temperature. Hardwood such as oak, hickory, mesquite, fruit and nut wood are an excellent fuel because of their burning rate. When using wood as fuel, make sure the wood is seasoned and dry. **DO NOT** use resinous wood such as pine as it will produce an unpleasant taste.

Adding Charcoal/Wood During Cooking

Additional charcoal and/or wood or an adjustment to the air vents may be necessary to maintain or increase cooking temperature.

Step 1

Stand back and carefully open grill lid. Use caution since flames can flare-up when fresh air suddenly comes in contact with fire.

 **WARNING:** Wear protective gloves or oven mitts when adjusting door handle, ash tray, cooking height or air vents.

Step 2

Use charcoal grate adjuster crank to place charcoal grate at the lowest level of cooking chamber. Open door to allow access to charcoal grate.

Step 3

Stand back a safe distance and use long cooking tongs to lightly brush aside ashes on hot coals. Use cooking tongs to add charcoal and/or wood to charcoal grate, being careful not to stir-up ashes and sparks. If necessary, use your Charcoal Chimney Starter to light additional charcoal and/or wood and add to existing fire.

 **WARNING:** Never add charcoal lighting fluid to hot or even warm coals as flashback may occur causing severe burns.

Step 4

When charcoal is burning strong again, wear oven mitts/gloves and carefully return charcoal grate to desired cooking level.

Step 5

Close the grill lid and door. Allow food to continue cooking.

AFTER-USE SAFETY

WARNING

- Always allow grill and all components to cool completely before handling.
- Never leave coals and ashes in grill unattended. Make sure coals and ashes are completely extinguished before removing.
- Before grill can be left unattended, remaining coals and ashes must be removed from grill. Use caution to protect yourself and property. Place remaining coals and ashes in a non-combustible metal container and completely saturate with water. Allow coals and water to remain in metal container 24 hours prior to disposing.
- Extinguished coals and ashes should be placed a safe distance from all structures and combustible materials.
- With a garden hose, completely wet surface beneath and around the grill to extinguish any ashes, coals or embers which may have fallen during the cooking or cleaning process.
- Cover and store grill in a protected area away from children and pets.

Proper Care & Maintenance

- Cure your grill periodically throughout the year to protect against excessive rust.
- To protect your grill from excessive rust, the unit must be properly cured and covered at all times when not in use. A smoker cover may be ordered directly from Brinkmann by calling 800-468-5252.
- Wash cooking grill and charcoal grate with hot, soapy water, rinse well and dry. Lightly coat grill with vegetable oil or vegetable oil spray.
- Clean inside and outside of grill by wiping off with a damp cloth. Apply a light coat of vegetable oil or vegetable oil spray to the interior surface to prevent rusting. Do not coat charcoal grate or charcoal ash tray.
- If rust appears on the exterior surface of your grill, clean and buff the affected area with steel wool or fine grit emery cloth. Touch-up with a good quality high-temperature resistant paint.
- Never apply paint to the interior surface. Rust spots on the interior surface can be buffed, cleaned, then lightly coated with vegetable oil or vegetable oil spray to minimize rusting.

FOR COVERS, ACCESSORIES AND OTHER PRODUCTS, PLEASE VISIT US ONLINE AT:

www.brinkmann.net

FOR GRILL WARRANTY REPLACEMENT PARTS, PLEASE VISIT US AT:

www.grillpartsonline.com

PARA CUBIERTAS, ACCESORIOS Y OTROS PRODUCTOS, FAVOR DE VISITARNOS POR LA RED MUNDIAL EN: www.brinkmann.net

PARA PARTES DE REEMPLAZO DE PARRILLA BAJO GARANTIA, FAVOR DE VISITARNOS POR LA RED MUNDIAL EN: www.grillpartsonline.com

ONE YEAR LIMITED WARRANTY

For one year from date of purchase, The Brinkmann Corporation warrants the Professional Stainless Steel Charcoal Grill against defects due to workmanship or materials to the original purchaser. The Brinkmann Corporation's obligations under this warranty are limited to the following guidelines:

- This warranty does not cover grills that have been altered/modified or damaged due to: normal wear, rust, abuse, improper maintenance and/or improper use.
- This warranty does not cover surface scratches or heat damage to the finish, which is considered normal wear.
- The Brinkmann Corporation may elect to repair or replace damaged units covered by the terms of this warranty.
- This warranty extends to the original purchaser only and is not transferable or assignable to subsequent purchasers.

The Brinkmann Corporation requires reasonable proof of purchase. Therefore, we strongly recommend that you retain your sales receipt or invoice. To obtain replacement parts for your Professional Stainless Steel Charcoal Grill under the terms of this warranty, please call Customer Service Department at 800-527-0717. **A receipt will be required.** The Brinkmann Corporation will not be responsible for any cookers forwarded to us without prior authorization. Professional Stainless Steel Charcoal Grill must be returned to the original place of purchase for replacement of the unit.

EXCEPT AS ABOVE STATED, THE BRINKMANN CORPORATION MAKES NO OTHER EXPRESS WARRANTY.

THE IMPLIED WARRANTIES OF MERCHANTABILITY AND FITNESS FOR A PARTICULAR PURPOSE ARE LIMITED IN DURATION TO ONE YEAR FROM THE DATE OF PURCHASE. SOME STATES DO NOT ALLOW LIMITATIONS ON HOW LONG AN IMPLIED WARRANTY LASTS, SO THE ABOVE LIMITATION MAY NOT APPLY TO YOU.

ANY LIABILITY FOR INDIRECT, INCIDENTAL OR CONSEQUENTIAL DAMAGES ARISING FROM THE FAILURE OF THE PROFESSIONAL STAINLESS STEEL CHARCOAL GRILL TO COMPLY WITH THIS WARRANTY OR ANY IMPLIED WARRANTY IS EXCLUDED. CUSTOMER ACKNOWLEDGES THAT THE PURCHASE PRICE CHARGED IS BASED UPON THE LIMITATIONS CONTAINED IN THE WARRANTY SET OUT ABOVE. SOME STATES DO NOT ALLOW THE EXCLUSION OR LIMITATION OF INCIDENTAL OR CONSEQUENTIAL DAMAGES, SO THE ABOVE LIMITATION OR EXCLUSION MAY NOT APPLY TO YOU. THIS WARRANTY GIVES YOU SPECIFIC LEGAL RIGHTS, AND YOU MAY ALSO HAVE OTHER RIGHTS WHICH VARY FROM STATE TO STATE.

GARANTÍA LIMITADA DE UN AÑO

Por un año a partir de la fecha de compra, The Brinkmann Corporation garantiza la Parrilla a Carbon Profesional de Acero Inoxidable contra defectos debidos a la mano de obra o materiales, al comprador original. Las obligaciones de The Brinkmann Corporation bajo esta garantía están limitadas a los siguientes lineamientos:

- Esta garantía no cubre parrillas que han sido alteradas/modificadas o dañadas debido al: desgaste ordinario, óxido, abuso, mantenimiento inapropiado y/o uso inapropiado.
- Esta garantía no cubre rayones en la superficie ni daño al acabado provocado por el calor, el cual es considerado desgaste ordinario.
- The Brinkmann Corporation puede elegir reparar o reemplazar unidades dañadas cubiertas bajo los términos de esta garantía.
- Esta garantía se extiende al comprador original únicamente y no es cedible ni asignable a compradores subsecuentes.

The Brinkmann Corporation requiere una prueba de compra razonable. Por lo tanto le recomendamos fuertemente que **conservar su recibo o factura**. Para obtener piezas de reemplazo para su Parrilla a Carbon Profesional de Acero Inoxidable conforme a los términos de esta garantía, por favor llame al Departamento de Servicio al Cliente al 800-527-0717. Un recibo será necesario. The Brinkmann Corporation no se hará responsable por cualquier parrilla que le sea remitida sin autorización previa. La Parrilla a Carbon Profesional de Acero Inoxidable debe ser devuelta al lugar original de la compra para el reemplazo de la unidad.

SALVO EN CUANTO A LO ANTERIORMENTE INDICADO, THE BRINKMANN CORPORATION NO HACE OTRA GARANTÍA EXPRESA.

LAS GARANTÍAS IMPLÍCITAS DE CALIDAD E IDONEIDAD PARA UN FIN CONCRETO ESTÁN LIMITADAS EN DURACIÓN A UN AÑO A PARTIR DE LA FECHA DE COMPRA. ALGUNOS ESTADOS NO PERMITEN LIMITACIONES EN CUANTO AL TIEMPO DE DURACIÓN DE UNA GARANTÍA IMPLÍCITA, POR LO QUE LA ANTERIOR LIMITACIÓN PODRÍA NO APLICARLE A USTED.

CUALQUIER RESPONSABILIDAD POR DAÑOS INDIRECTOS, INCIDENTALES O EMERGENTES RESULTANTE DE FALLAS DE LA PARRILLA A CARBON PROFESIONAL DE ACERO INOXIDABLE PARA CUMPLIR CON ESTA GARANTÍA O CUALQUIER GARANTÍA IMPLÍCITA QUEDA EXCLUIDA. EL CONSUMIDOR ACEPTA QUE EL PRECIO DE COMPRA ESTÁ BASADO EN LAS LIMITACIONES CONTENIDAS EN LA GARANTÍA ESTABLECIDA ARRIBA. ALGUNOS ESTADOS NO PERMITEN LA EXCLUSIÓN NI LIMITACIÓN DE LOS DAÑOS INCIDENTALES O EMERGENTES, ASÍ QUE LA LIMITACIÓN O EXCLUSIÓN QUE APARECE ARRIBA PODRÍA NO APLICARLE A USTED. ESTA GARANTÍA LE DA A USTED DERECHOS LEGALES ESPECÍFICOS, Y USTED TAMBIÉN PODRÍA TENER OTROS DERECHOS QUE VARIAN DE ESTADO A ESTADO.