

HEAT CONTROLLER, INC.

**Wall Mounted
Multi-Split System
Air Conditioning/Heat Pump**
Service Manual

Model: Indoor Unit: B-MMC09FA-1
B-MMH09FA-1
B-MMC12FA-1
B-MMH12FA-1

Outdoor Unit : A-MMH18FA-1
A-MMC24FA-1
A-MMH24FA-1
A-MMC36FA-1
A-MMH36FA-1

CAUTION

Before servicing the unit, read the
“safety precautions” in this manual.

Only for authorized service personnel.

TABLE OF CONTENTS

Combination table	3
Safety Precautions	4
Installation guide at the seaside	10
Dimensions	11
Indoor Unit.....	11
Outdoor Unit.....	12
Product Specifications	15
Indoor Unit.....	15
Outdoor Unit.....	16
Installation	19
Installation Parts.....	19
Installation Tools.....	19
Select the best location.....	20
Piping length and elevation.....	21
Fixing Installation Plate(Standard Type).....	22
Drill a hole in the wall.....	22
Flaring Work and Connection of Piping	23
Flaring work.....	24
Connecting the Piping.....	24
Connecting the Cable between Indoor Unit and Outdoor Unit	31
Connect the cable to the Indoor unit.....	31
Connect the cable to the Outdoor unit.....	32
Connection method of the connecting cable(Example).....	33
Connect the cable to the indoor unit.....	34
Checking the Drainage, Forming the Pipings and Long Pipe Setting	35
Checking the drainage.....	35
Forming the piping.....	36
Air Purging and Evacuation	37
Checking method.....	37
Evacuation.....	38
Charging	39
Test Running	40
Operation	41
Function of control.....	41
Function of Indoor Unit.....	46
Function of Outdoor Unit.....	47
Remote Control Operation.....	48
Disassembly	49
Indoor Unit.....	49
Schematic Diagram	52
Electronic Control Device.....	52
Wiring Diagram.....	55
Components Locations.....	57
Troubleshooting Guide	61
Refrigeration Cycle Diagram.....	61
Self-diagnosis Function.....	64
Cycle Troubleshooting Guide.....	65
Electronic Parts Troubleshooting Guide.....	66
Error Code.....	71
2-way, 3-way Valve	75
Exploded View	79
Indoor Unit.....	79
Outdoor Unit.....	81

Combination table

18 kBtu(2 rooms)

	Combination		
	Unit-A	Unit-B	Total
1 UNIT	9	-	9
2 UNIT	9	9	18

24 kBtu(2 rooms)

	Combination		
	Unit-A	Unit-B	Total
1 UNIT	9	-	9
	12	-	12
2 UNIT	9	9	18
	9	12	21
	12	12	24

36 kBtu (3 rooms)

	Combination			
	Unit-A	Unit-B	Unit-C	Total
1 UNIT	9	-	-	9
	12	-	-	12
2 UNIT	9	9	-	18
	9	12	-	21
	12	12	-	24
3 UNIT	9	9	9	27
	9	9	12	30
	9	12	12	33
	12	12	12	36

Notes :

- Cooling Capacity is based on : indoor temp. 26.7°C(80.1°F)DB, 19.4°C(66.9°F)WB; outdoor temp. 35°C(95°F)DB, 23.9°C(75°F)WB
- Heating Capacity is based on : indoor temp. 21.1°C(70°F)DB, 15.6°C(60.1°F)WB; outdoor temp. 8.3°C(46.9°F)DB, 6.1°C(43°F)WB



This symbol alerts you to the risk of electric shock.



This symbol alerts you to hazards that could cause harm to the air conditioner.



This symbol indicates special notes.

Safety Precautions



To prevent injury to the user or other people and property damage, the following instructions must be followed.

■ Incorrect operation due to ignoring instruction will cause harm or damage. The seriousness is classified by the following indications.

⚠ WARNING This symbol indicates the possibility of death or serious injury.

⚠ CAUTION This symbol indicates the possibility of injury or damage to properties only.

■ Meanings of symbols used in this manual are as shown below.

	Be sure not to do.
	Be sure to follow the instruction.

⚠ WARNING

■ Installation

Do not use a defective or under-rated circuit breaker. Use this appliance on a dedicated circuit.

- There is risk of fire or electric shock.

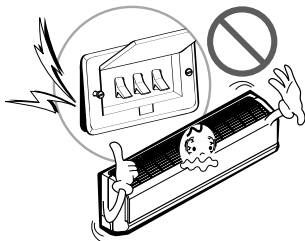

For electrical work, contact the dealer, seller, a qualified electrician, or an Authorized Service Center.

- Do not disassemble or repair the product. There is risk of fire or electric shock.

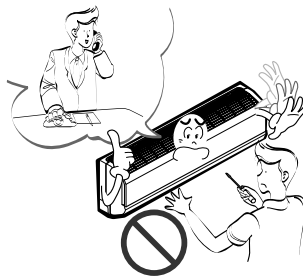

Always ground the product.

- There is risk of fire or electric shock.

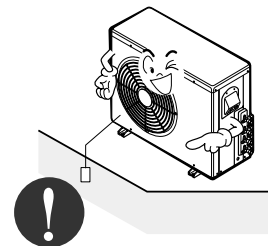

Install the panel and the cover of control box securely.

- There is risk of fire or electric shock.

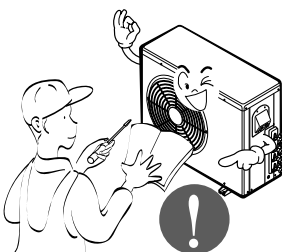

Always install a dedicated circuit and breaker.

- Improper wiring or installation may cause fire or electric shock

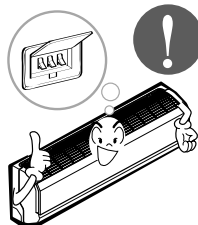

Use the correctly rated breaker or fuse.

- There is risk of fire or electric shock.

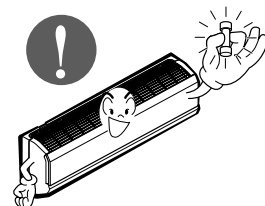

Do not install, remove, or re-install the unit by yourself (customer).

- There is risk of fire, electric shock, explosion, or injury.

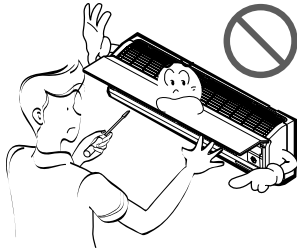

Be cautious when unpacking and installing the product.

- Sharp edges could cause injury. Be especially careful of the case edges and the fins on the condenser and evaporator.

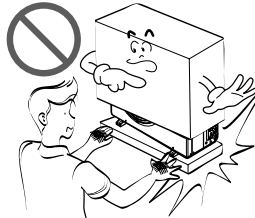

For installation, always contact the dealer or an Authorized Service Center.

- There is risk of fire, electric shock, explosion, or injury.

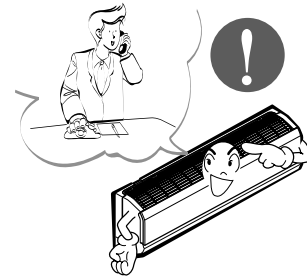

Do not install the product on a defective installation stand.

- It may cause injury, accident, or damage to the product.

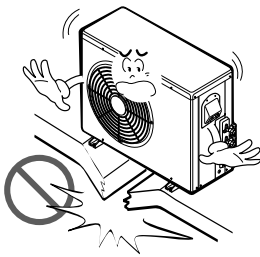

Be sure the installation area does not deteriorate with age.

- If the base collapses, the air conditioner could fall with it, causing property damage, product failure, and personal injury.

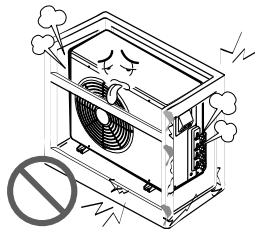

Do not let the air conditioner run for a long time when the humidity is very high and a door or a window is left open.

- Moisture may condense and wet or damage furniture.



Do not allow water to run into electric parts.

- It may cause There is risk of fire, failure of the product, or electric shock.

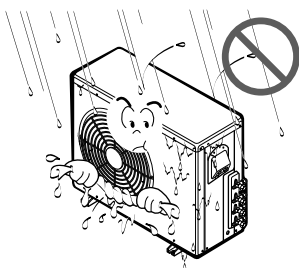

Do not store or use flammable gas or combustibles near the product.

- There is risk of fire or failure of product.



Do not use the product in a tightly closed space for a long time.

- Oxygen deficiency could occur.

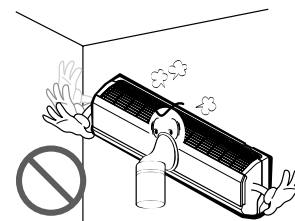

When flammable gas leaks, turn off the gas and open a window for ventilation before turn the product on.

- Do not use the telephone or turn switches on or off. There is risk of explosion or fire

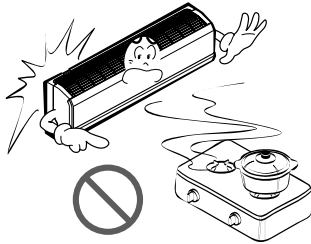

If strange sounds, or smoke comes from product. Turn the breaker off.

- There is risk of electric shock or fire.



Stop operation and close the window in storm or hurricane. If possible, remove the product from the window before the hurricane arrives.

- There is risk of property damage, failure of product, or electric shock.

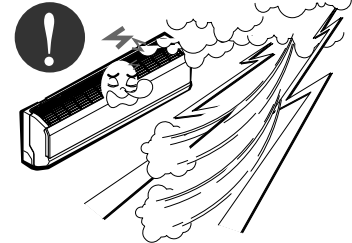

Do not open the inlet grill of the product during operation. (Do not touch the electrostatic filter, if the unit is so equipped.)

- There is risk of physical injury, electric shock, or product failure.



When the product is soaked (flooded or submerged), contact an Authorized Service Center.

- There is risk of fire or electric shock.



Be cautious that water could not enter the product.

- There is risk of fire, electric shock, or product damage.

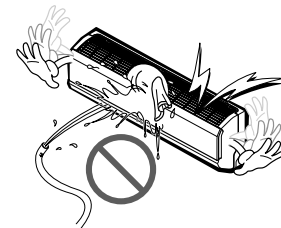

Ventilate the product from time to time when operating it together with a stove, etc.

- There is risk of fire or electric shock.

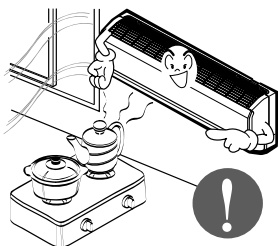

Turn the main power off when cleaning or maintaining the product.

- There is risk of electric shock.

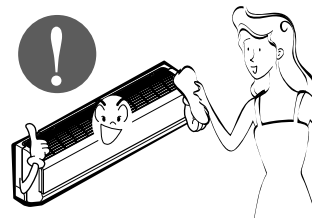

When the product is not to be used for a long time, disconnect the power by turning off the breaker.

- There is risk of product damage or failure, or unintended operation.

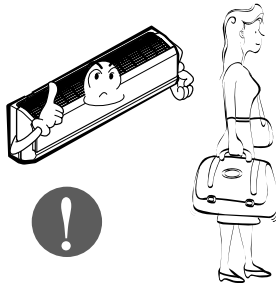

Take care to ensure that nobody could step on or fall onto the outdoor unit.

- This could result in personal injury and product damage.



CAUTION

Installation

Always check for gas (refrigerant) leakage after installation or repair of product.

- Low refrigerant levels may cause failure of product.

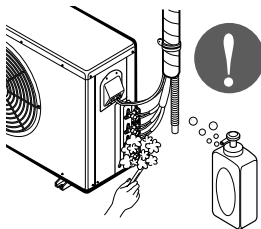

Install the drain hose to ensure that water is drained away properly.

- A bad connection may cause water leakage.

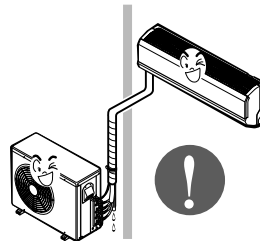

Keep level even when installing the product.

- To avoid vibration or water leakage.

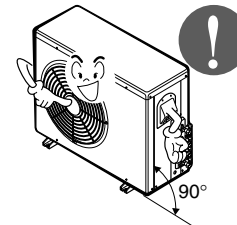

Do not install the product where the noise or hot air from the outdoor unit could offend neighbors.

- It may cause a problem for your neighbors.

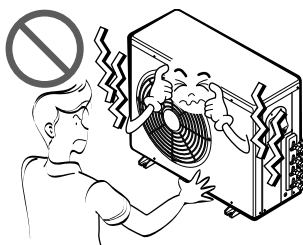

Use two or more people to lift and transport the product.

- Avoid personal injury.

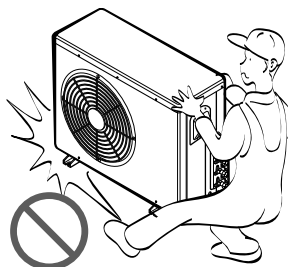

Do not install the product where it will be exposed to sea wind (salt spray) directly.

- It may cause corrosion on the product. Corrosion, particularly on the condenser and evaporator fins, could cause product malfunction or inefficient operation.

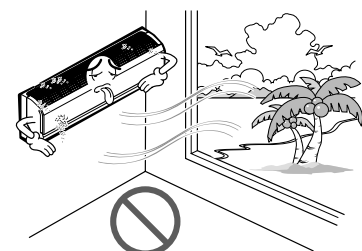

■ Operational

Do not expose the skin directly to cool air for long periods of time. (Don't sit in the draft.)

- This could harm to your health.

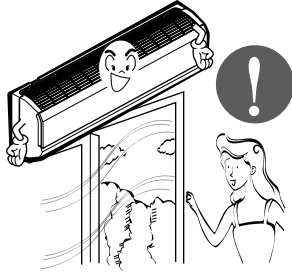

Do not use the product for special purposes, such as preserving foods, works of art, etc. It is a consumer air conditioner, not a precision refrigeration system.

- There is risk of damage or loss of property.

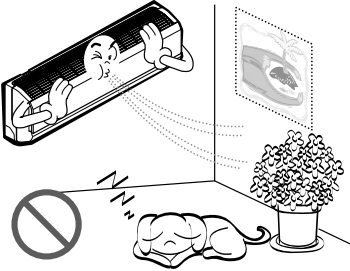

Do not block the inlet or outlet of air flow.

- It may cause product failure.

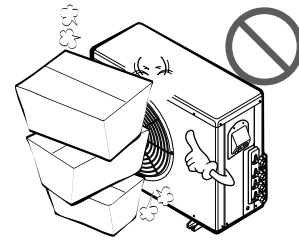

Use a soft cloth to clean. Do not use harsh detergents, solvents, etc.

- There is risk of fire, electric shock, or damage to the plastic parts of the product.



Do not touch the metal parts of the product when removing the air filter. They are very sharp!

- There is risk of personal injury.



Do not step on or put anything on the product. (outdoor units)

- There is risk of personal injury and failure of product.



Always insert the filter securely. Clean the filter every two weeks or more often if necessary.

- A dirty filter reduces the efficiency of the air conditioner and could cause product malfunction or damage.



Do not insert hands or other objects through the air inlet or outlet while the product is operated.

- There are sharp and moving parts that could cause personal injury.

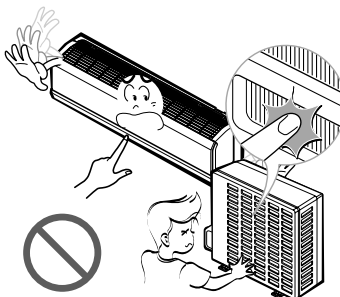

Do not drink the water drained from the product.

- It is not sanitary and could cause serious health issues.



Use a firm stool or ladder when cleaning or maintaining the product.

- Be careful and avoid personal injury.

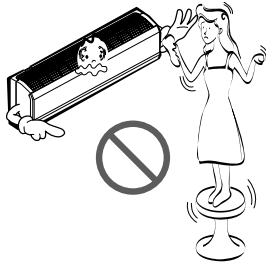

Replace the all batteries in the remote control with new ones of the same type. Do not mix old and new batteries or different types of batteries.

- There is risk of fire or explosion

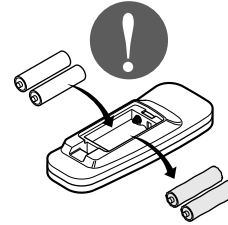

Do not recharge or disassemble the batteries. Do not dispose of batteries in a fire.

- They may burn or explode.

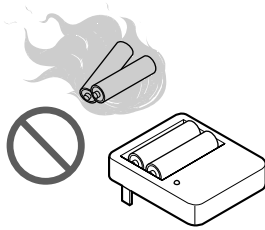

If the liquid from the batteries gets onto your skin or clothes, wash it well with clean water. Do not use the remote if the batteries have leaked.

- The chemicals in batteries could cause burns or other health hazards.



If you eat the liquid from the batteries, brush your teeth and see doctor. Do not use the remote if the batteries have leaked.

- The chemicals in batteries could cause burns or other health hazards.



Installation guide at the seaside

⚠ CAUTION

1. Air conditioners should not be installed in areas where corrosive gases, such as acid or alkaline gas, are produced.
2. Do not install the product where it could be exposed to sea wind (salty wind) directly. It can result corrosion on the product. Corrosion, particularly on the condenser and evaporator fins, could cause product malfunction or inefficient performance.
3. If outdoor unit is installed close to the seaside, it should avoid direct exposure to the sea wind. Otherwise it needs additional anticorrosion treatment on the heat exchanger.

Selecting the location(Outdoor Unit)

- 1) If the outdoor unit is to be installed close to the seaside, direct exposure to the sea wind should be avoided. Install the outdoor unit on the opposite side of the sea wind direction.

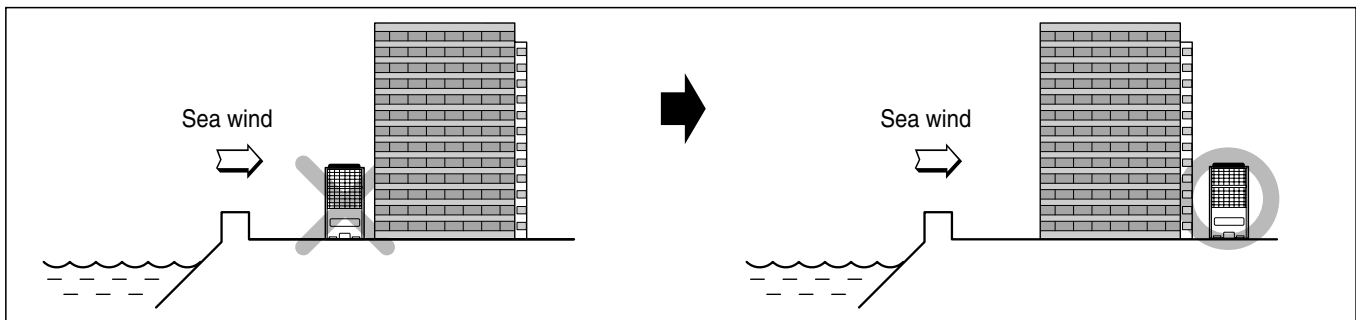

- 2) In case, to install the outdoor unit on the seaside, set up a windbreak not to be exposed to the sea wind.

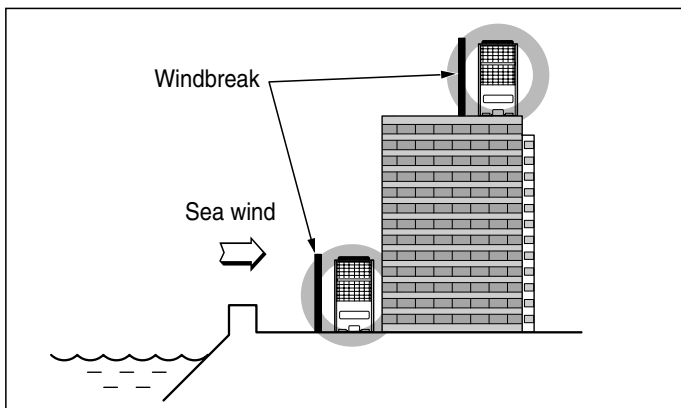

- It should be strong enough like concrete to prevent the sea wind from the sea.
- The height and width should be more than 150% of the outdoor unit.
- It should be keep more than 70 cm of space between outdoor unit and the windbreak for easy air flow.

- 3) Select a well-drained place.

1. If you can't meet above guide line in the seaside installation, please contact LG Electronics for the additional anticorrosion treatment.
2. Periodic (more than once/year) cleaning of the dust or salt particles stuck on the heat exchanger by using water

Dimensions

Indoor Unit

Split Type Indoor

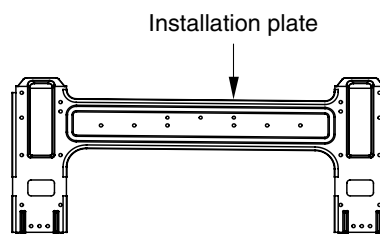
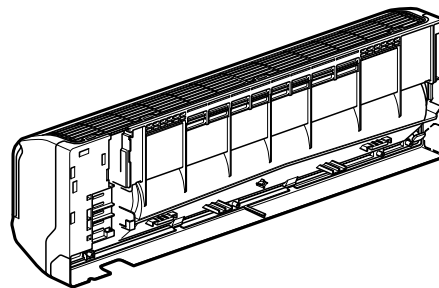
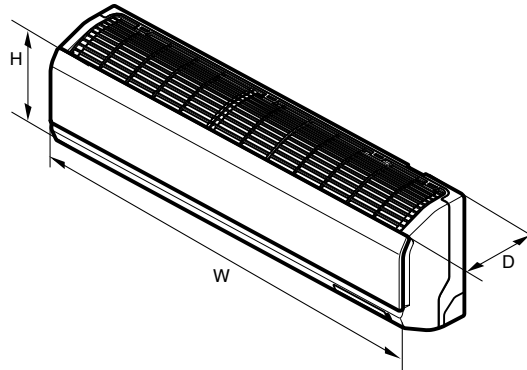

Dimension \ Model		Split Type	
		S4	SE
		9 kBtu/h	12 kBtu/h
W	mm(in)	840(33)	895(35.2)
H	mm(in)	270(10.6)	282(11.1)
D	mm(in)	153(6)	165(6.5)

Outdoor Unit

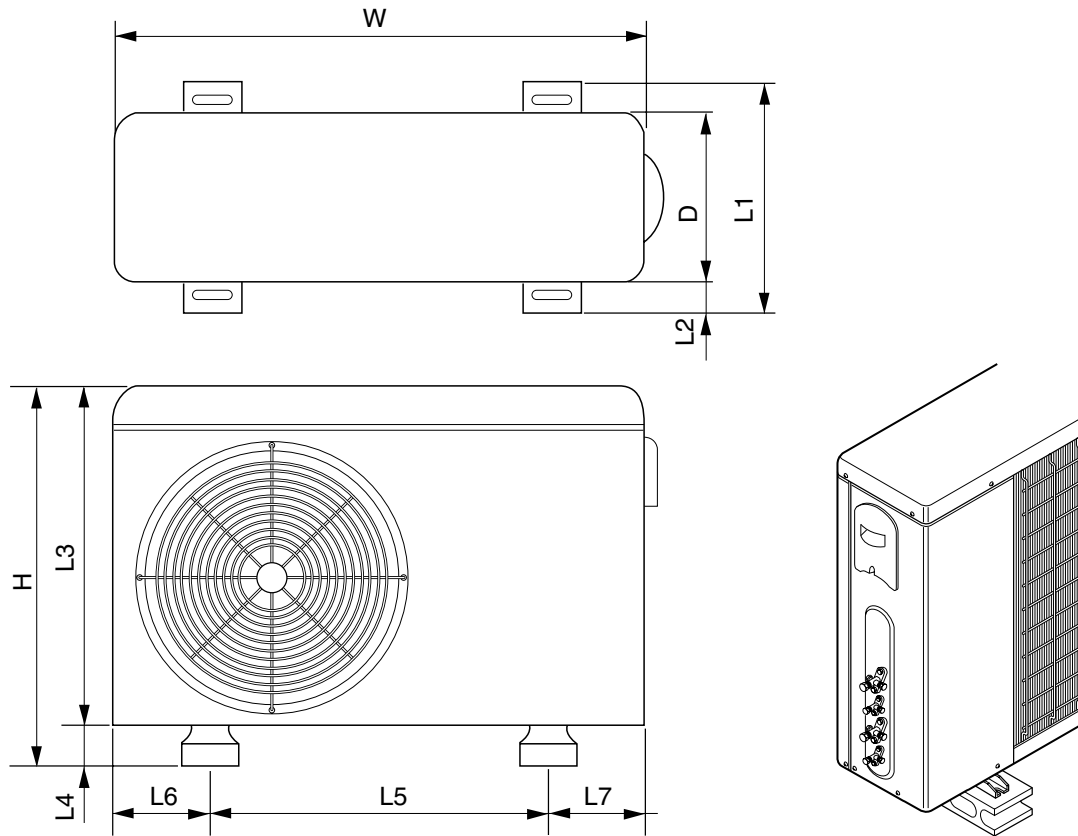

DIM \ MODEL		UE 18kBtu/h
W	mm(in)	870(34.3)
H	mm(in)	655(25.8)
D	mm(in)	320(12.6)
L1	mm(in)	370(14.6)
L2	mm(in)	25(1.0)
L3	mm(in)	775(30.5)
L4	mm(in)	25(1.0)
L5	mm(in)	546(21.5)
L6	mm(in)	160(6.3)
L7	mm(in)	160(6.3)

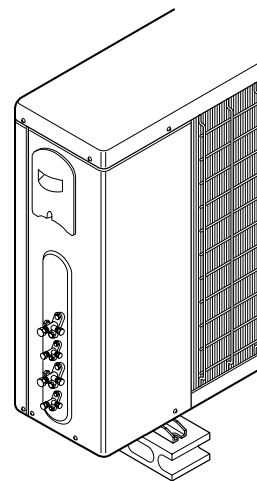
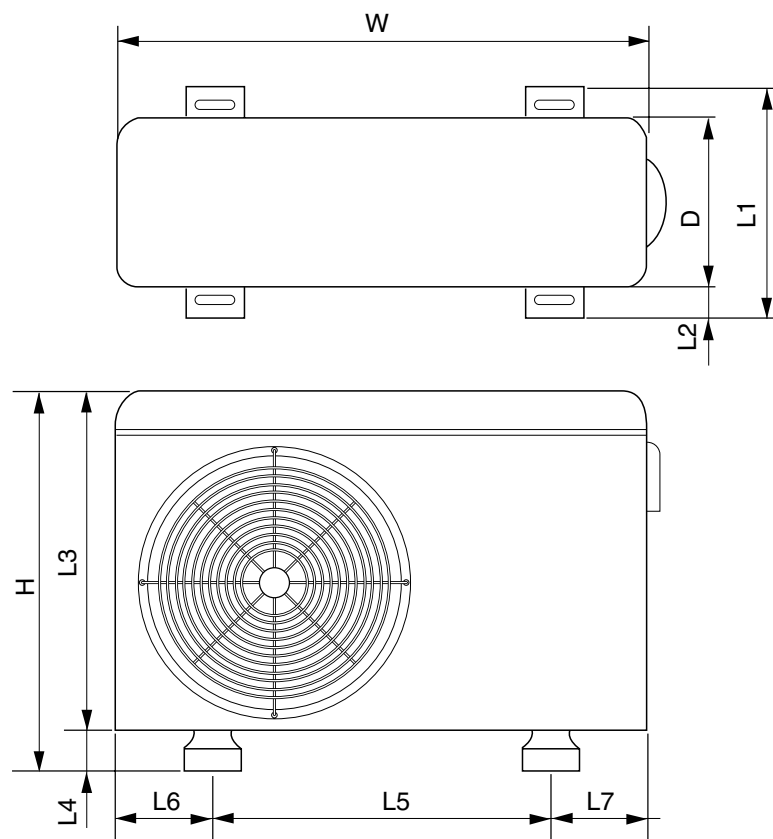

DIM \ MODEL		UE 1 24kBTu/h
W	mm(in)	870(34.3)
H	mm(in)	808(31.8)
D	mm(in)	320(12.6)
L1	mm(in)	370(14.6)
L2	mm(in)	25(1.0)
L3	mm(in)	775(30.5)
L4	mm(in)	25(1.0)
L5	mm(in)	546(21.5)
L6	mm(in)	160(6.3)
L7	mm(in)	160(6.3)

Dimensions

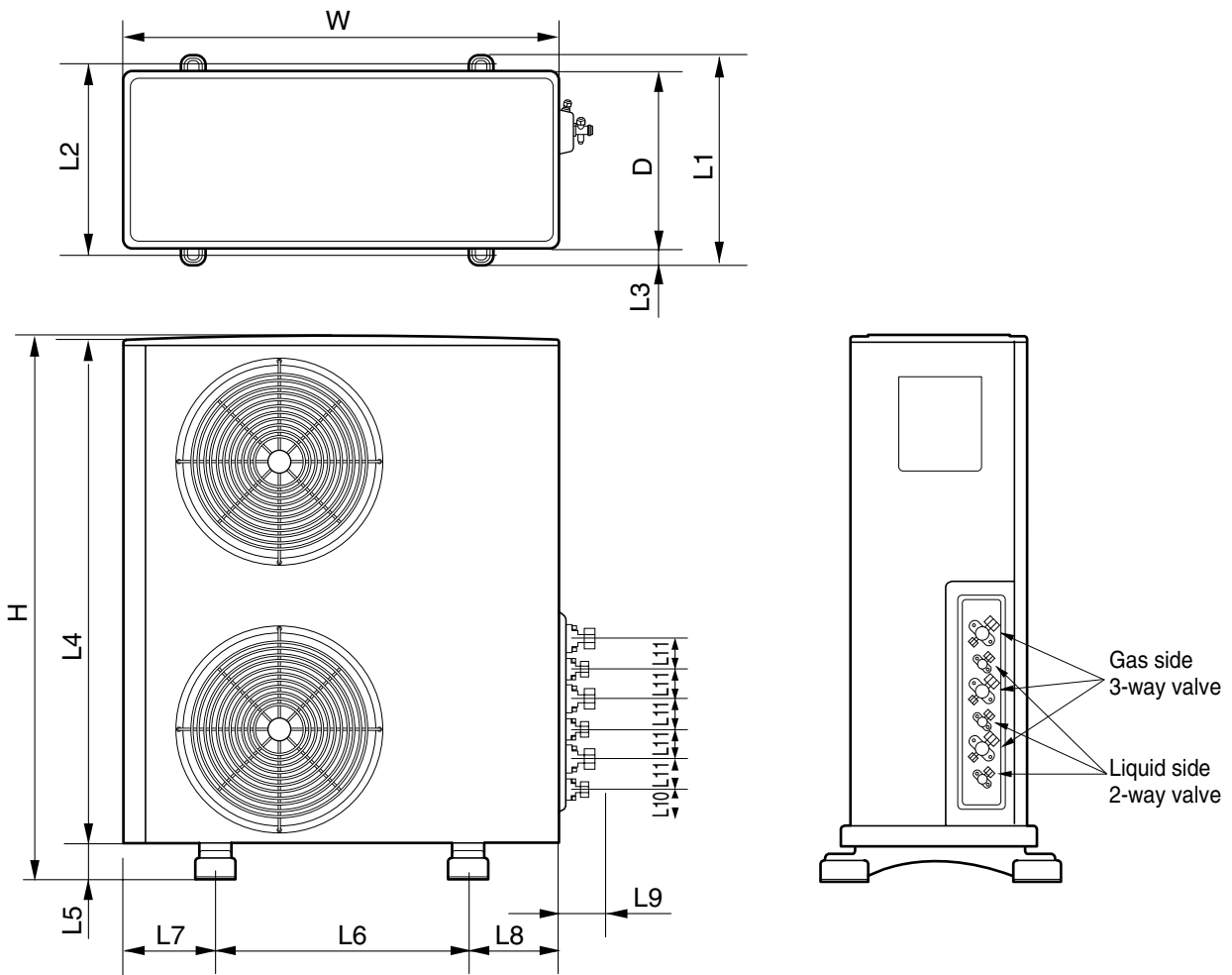

DIM		MODEL	UE2 36kBTu/h
W		mm(in)	870(34.3)
H		mm(in)	1038(40.7)
D		mm(in)	320(12.6)
L1		mm(in)	360(14.2)
L2		mm(in)	340(13.4)
L3		mm(in)	25(1.0)
L4		mm(in)	1035(40.8)
L5		mm(in)	25(1.0)
L6		mm(in)	546(21.5)
L7		mm(in)	160(6.3)
L8		mm(in)	160(6.3)
L9		mm(in)	44(11.7)
L10		mm(in)	64.5(2.5)
L11		mm(in)	50(2.0)

Product Specifications

Indoor Unit

Indoor Unit Type			Wall Mounted			
Model			B-MMC09FA-1	B-MMH09FA-1	B-MMC12FA-1	B-MMH12FA-1
Nominal Cooling Capacity *	kcal/h(W)		2,267(2,637)	2,267(2,637)	3,023(3,516)	3,023(3,516)
	Btu/h		9,000	9,000	12,000	12,000
Nominal Heating Capacity *	kcal/h(W)		-	2,267(2,637)	-	3,023(3,516)
	Btu/h		-	9,000	-	12,000
Air Circulation	H/M/L	CMM(CFM)	8.2(289)	8.2(289)	9.4(332)	9.4(332)
Setting temperature range(cool/heat)		°C	18~30	18~30	18~30	18~30
Fan motor	Output	W	15	15	15	15
	Model		DL-88430LGIF	DL-88430LGIF	DL-88430LGIF	DL-88430LGIF
	Input	V	DC36	DC36	DC36	DC36
	Running Current	A	0.15	0.15	0.15	0.15
Fan	Type		Cross Flow Fan	Cross Flow Fan	Cross Flow Fan	Cross Flow Fan
	No. Used / Diameter	EA/inch(mm)	1/3.74(95)	1/3.74(95)	1/3.74(95)	1/3.74(95)
Noise Level (Sound Press,1m) H/M/L		dBA	31 / 29 / 22	31 / 29 / 22	36 / 32 / 29	36 / 32 / 29
Temperature controller			Thermistor	Thermistor	Thermistor	Thermistor
Coil	Tube Size (OD)	inch(mm)	0.197(5.0)	0.197(5.0)	0.197(5.0)	0.197(5.0)
	Fins per inch		20	20	18	18
	No. of Rows & Column		2R,15C	2R,15C	2R,15C	2R,15C
Dehumidification Rate		l/h	-	1.1	-	1.2
Dimensions (W*H*D)		inch(mm)	33.0*10.6*6.0(840*270*153)	33.0*10.6*6.0(840*270*153)	35.2*11.1*6.5(895*282*165)	35.2*11.1*6.5(895*282*165)
Net Weight		kg(lbs)	7(15.4)	7(15.4)	9.5(20.9)	9.5(20.9)
Piping Connection	Liquid	inch(mm)	1/4 (6.35)	1/4 (6.35)	1/4 (6.35)	1/4 (6.35)
	Gas	inch(mm)	3/8 (9.52)	3/8 (9.52)	3/8 (9.52)	3/8 (9.52)
	Drain hose (ID Ø)	mm	20	20	20	20
Packing Dimension (W*H*D)		inch(mm)	35.7*13.1*8.8(906*332*223)	35.7*13.1*8.8(906*332*223)	38.3*9.1*14.6(973*231*372)	38.3*9.1*14.6(973*231*372)
Stuffing Quantity	With(Without) S/Parts	20/40ft(hi-c)	440/910 (1091)	440/910 (1091)	353/719 (792)	353/719 (792)

Note : 1.★ See the page "Combination Table"

2. Due to our policy of innovation some specifications may be changed without notification.

Outdoor Unit - Multiple piping models

Model			A-MMH18FA-1
Cooling Capacity★	Btu/hr		9,000~18,000
	W		2637~5275
	kcal/hr		2267~4536
Heating Capacity★	Btu/hr		9,000~18,000
	W		2637~5275
	kcal/hr		2267~4536
Input★	Cooling	W	1070~1980
	Heating	W	1040~1960
Running Current★(208/230V)	Cooling	A	4.9~8.8
	Heating	A	4.6~8.6
Power Supply		∅, V, Hz	1,208/230,60
Max. Number of Connectable Indoor Units			2
Compressor (Constant)	Type		Rotary
	Model		GK094K
	Motor Type		Hermetic
	Quantity	Ea	1
	Motor Input	W	955
	Oil Charge	cc	330±10
	Oil Type		FVC68D
	Capacitor	μF/Vac	30 / 370
O.L.P Type(model name)			External Type(MRA98996-12026)
Compressor (Constant)	Type		Rotary
	Model		GK113K
	Motor Type		Hermetic
	Quantity	Ea	1
	Motor Input	W	1,120
	Oil Charge	cc	330±10
	Oil Type		FVC68D
	Capacitor	μF/Vac	35 / 370
O.L.P Type(model name)			External Type(MRA12124-12026)
Refrigerant charge	Charge	g(oz)	1400(49)
	Type		R410A
	Control		EEV
Coil	Tube Size (OD)	inch(mm)	0.276(7.0)
	Fins per inch		18
	No. of Rows & Column/No.		2R,28C
Fan motor	Model		IC-1640LG GE
	Output	W	90
	Capacitor	μF/Vac	6/370
Fan	Type		Propeller
	No. Used / Diameter	EA/inch(mm)	1 / 460
	Discharge	Side / Top	Side
Air Circulation	Outdoor	CMM(CFM)	50(1765.7)
Noise Level(H/L) at 230V	Sound Press, 1m	dB(A) ± 1	51
Defrosting			Inversion Cycle
SVC Valve	Liquid	inch(mm)	1/4 (6.35) * 2EA
	Gas		3/8 (9.52) * 2EA
Dimensions	W*H*D	inch(mm)	34.3*25.8*12.6 (870*655*320)
Net Weight	Outdoor	kg(lbs)	57(125.7)
Max. Interunit Piping Length	Total of Each Room	m	30
	For One Room	m	15
Max. Installation	Indoor Unit~Outdoor Unit	m	7.5
Height Difference	Indoor Unit~Indoor Unit	m	7.5
Packing Dimension	W*H*D	inch(mm)	40.2*28.2*17.2 (1020*716*437)
Testing Combinations			S4 9k + S4 9k
Stuffing Quantity		20/40ft	81/171

Note:

- Capacities are based on the following conditions:
 - Cooling:
 - Indoor Temperature 26.7°C(80°F) DB/19.4°C(67°F) WB
 - Outdoor Temperature 35°C(95°F) DB/23.9°C(75°F) WB
 - Heating:
 - Indoor Temperature 21.1°C(70°F) DB/15.6°C(60°F) WB
 - Outdoor Temperature 8.3°C(47°F) DB/6.1°C(43°F) WB
 - Piping Length
 - Interconnecting Piping Length 7.5m
 - Level Difference of Zero
- Wiring cable size must comply with the applicable local and national code.
- Capacities are Net Capacities.
- ★: See the page "Combination Table"
- The specification may be subject to change without prior notice for purpose of improvement.

Model			A-MMC24FA-1	A-MMH24FA-1
Cooling Capacity★	Btu/hr		9,000~24,000	9,000~24,000
	W		2637~7033	2637~7033
	kcal/hr		2267~6037	2267~6037
Heating Capacity★	Btu/hr		-	9,000~24,000
	W		-	2637~7033
	kcal/hr		-	2267~6037
Input★	Cooling	W	1170~2390	1170~2390
	Heating	W	-	1220~2440
Running Current★(208/230V)	Cooling	A	7.7~10.1	7.7~10.1
	Heating	A	-	7.4~9.8
Power Supply		∅, V, Hz	1,208/230,60	1,208/230,60
Max. Number of Connectable Indoor Units			2	2
Compressor (Constant)	Type		Rotary	Rotary
	Model		GK094K	GK094K
	Motor Type		Hermetic	Hermetic
	Quantity	Ea	1	1
	Motor Input	W	955	955
	Oil Charge	cc	330±10	330±10
	Oil Type		FVC68D	FVC68D
	Capacitor	μF/Vac	30 / 370	30 / 370
O.L.P Type(model name)		External Type(MRA98996-12026)		
Compressor (Constant)	Type		Rotary	Rotary
	Model		GK141K	GK141K
	Motor Type		Hermetic	Hermetic
	Quantity	Ea	1	1
	Motor Input	W	1430	1,430
	Oil Charge	cc	350±10	350±10
	Oil Type		FVE	FVE
	Capacitor	μF/Vac	35 / 370	35 / 370
O.L.P Type(model name)		External Type(MRA12105-12026)		
Refrigerant charge	Charge	g(oz)	1600	1600
	Type		R410A	R410A
	Control		EEV	EEV
Coil	Tube Size (OD)	inch(mm)	0.276(7.0)	0.276(7.0)
	Fins per inch		18	18
	No. of Rows & Column/No.		2R,36C	2R,36C
Fan motor	Model		IC-1640LG GE	IC-1640LG GE
	Output	W	90	90
	Capacitor	μF/Vac	6/370	6/370
Fan	Type		Propeller	Propeller
	No. Used / Diameter	EA/inch(mm)	1 / 460	1 / 460
	Discharge	Side / Top	Side	Side
Air Circulation	Outdoor	CMM(CFM)	53(1872)	53(1872)
Noise Level(H/L) at 230V	Sound Press,1m	dB(A) ±1	54	54
Defrosting			-	Inversion Cycle
SVC Valve	Liquid	inch(mm)	1/4 (6.35) * 2EA	1/4 (6.35) * 2EA
	Gas		3/8 (9.52) * 2EA	3/8 (9.52) * 2EA
Dimensions	W*H*D	inch(mm)	34.3*31.8*12.6 (870*808*320)	34.3*31.8*12.6 (870*808*320)
Net Weight	Outdoor	kg(lbs)	64(141.1)	64(141.1)
Max. Interunit Piping Length	Total of Each Room	m	30	30
	For One Room	m	15	15
Max. Installation Height Difference	Indoor Unit~Outdoor Unit	m	7.5	7.5
	Indoor Unit~Indoor Unit	m	7.5	7.5
Packing Dimension	W*H*D	inch(mm)	40.2*34.3*17.2 (1022*870*437)	40.2*34.3*17.2 (1022*870*437)
Testing Combinations			SE 12K +SE 12K	SE 12K +SE 12K
Stuffing Quantity		20/40ft	54/114	54/114

Note:

- Capacities are based on the following conditions:
 - Cooling: - Indoor Temperature 26.7°C(80°F) DB/19.4°C(67°F) WB
 - Outdoor Temperature 35°C(95°F) DB/23.9°C(75°F) WB
 - Heating: - Indoor Temperature 21.1°C(70°F) DB/15.6°C(60°F) WB
 - Outdoor Temperature 8.3°C(47°F) DB/6.1°C(43°F) WB
- Piping Length - Interconnecting Piping Length 7.5m
- Level Difference of Zero
2. Wiring cable size must comply with the applicable local and national code.
3. Capacities are Net Capacities.
4. ★: See the page "Combination Table"
5. The specification may be subject to change without prior notice for purpose of improvement.

Product Specifications

Model			A-MMC36FA-1	A-MMH36FA-1
Cooling Capacity★	Btu/hr		9,000~36,000	9,000~36,000
	W		2637~10,550	2637~10,550
	kcal/hr		2267~9071	2267~9071
Heating Capacity★	Btu/hr		-	9,000~36,000
	W		-	2637~10,550
	kcal/hr		-	2267~9071
Input★	Cooling	W	1320~3680	1320~3680
	Heating	W	-	1410~3340
Running Current★(208/230V)	Cooling	A	5.9~16.6	5.9~16.6
	Heating	A	-	6.3~15.0
Power Supply		Ø, V, Hz	1,208/230,60	1,208/230,60
Max. Number of Connectable Indoor Units			3	3
Compressor (Constant)	Type		Rotary	Rotary
	Model		GK141K	GK141K
	Motor Type		2 Pole Induction(PSC)	2 Pole Induction(PSC)
	Quantity	Ea	1	1
	Motor Input	W	1430	1430
	Oil Charge	cc	350A}10	350A}10
	Oil Type		FVC68D	FVC68D
	Capacitor	µF/Vac	35 / 370	35 / 370
	O.L.P Type(model name)		External Type	External Type
Compressor (Constant)	Type		Rotary	Rotary
	Model		GJ230K	GJ230K
	Motor Type		2 Pole Induction(PSC)	2 Pole Induction(PSC)
	Quantity	Ea	1	1
	Motor Input	W	2370	2370
	Oil Charge	cc	700±10	7000±10
	Oil Type		FVC68D	FVC68D
	Capacitor	µF/Vac	50 / 400	50 / 400
	O.L.P Type(model name)		Internal Type	Internal Type
Refrigerant charge	Charge	g(oz)	2400	2400
	Type		R410A	R410A
	Control		EEV	EEV
Coil	Tube Size (OD)	inch(mm)	0.276(7.0)	0.276(7.0)
	Fins per inch		18	18
	No. of Rows & Column/No.		2R,48C	2R,48C
Fan motor	Model		ARC286B01 * 2	ARC286B01 * 2
	Output	W	102	102
	Capacitor	µF/Vac	2/370	2/370
Fan	Type		Propeller	Propeller
	No. Used / Diameter	EA/inch(mm)	2 / 15.7(400)	2 / 15.7(400)
	Discharge	Side / Top	Side	Side
Air Circulation	Outdoor	CMM(CFM)	63(2225)	63(2225)
Noise Level(H/L) at 230V	Sound Press, 1m	dB(A) ± 1	51	51
SVC Valve	Liquid	inch(mm)	1/4 (6.35) * 3EA	1/4 (6.35) * 3EA
	Gas		3/8 (9.52) * 3EA	3/8 (9.52) * 3EA
Dimensions	W*H*D	inch(mm)	34.3*40.7*12.6 (870*1038*320)	34.3*40.7*12.6 (870*1038*320)
Net Weight	Outdoor	kg(lbs)	84(185.2)	84(185.2)
Max. Interunit Piping Length	Total of Each Room	m	45	45
	For One Room	m	15	15
Max. Installation Height Difference	Indoor Unit-Outdoor Unit	m	7.5	7.5
	Indoor Unit-Indoor Unit	m	7.5	7.5
Packing Dimension	W*H*D	inch(mm)	41.3*44.9*17.3 (1048*1140*439)	41.3*44.9*17.3 (1048*1140*439)
Stuffing Quantity		20/40ft	53/111	53/111



Note:

- Capacities are based on the following conditions:
 - Cooling:
 - Indoor Temperature 26.7°C(80°F) DB/19.4°C(67°F) WB
 - Outdoor Temperature 35°C(95°F) DB/23.9°C(75°F) WB
 - Heating:
 - Indoor Temperature 21.1°C(70°F) DB/15.6°C(60°F) WB
 - Outdoor Temperature 8.3°C(47°F) DB/6.1°C(43°F) WB
 - Piping Length
 - Interconnecting Piping Length 7.5m
 - Level Difference of Zero
- Wiring cable size must comply with the applicable local and national code.
- Capacities are Net Capacities.
- ★: See the page "Combination Table"
- The specification may be subject to change without prior notice for purpose of improvement.





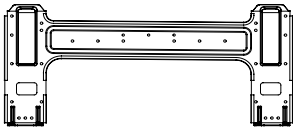

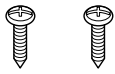
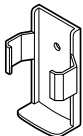

Installation

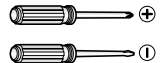
Read carefully, and then follow step by step.

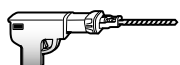
Installation Parts

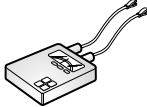
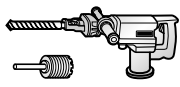
<p>Installation plate</p>	<p>Type "A" screw and plastic anchor</p>
	
<p>Type "B" screw</p>	<p>Remote Control Holder</p>
	

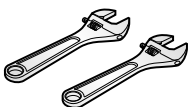
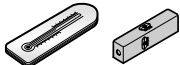
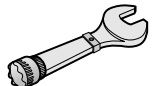
Installation Tools

Figure	Name	Figure	Name
	<p>Screw driver</p>		<p>Ohmmeter</p>
	<p>Electric Drill</p>		<p>Hexagonal wrench</p>
	<p>Measuring Tape, Knife</p>		<p>Ammeter</p>
	<p>Hole Core Drill</p>		<p>Gas Leak Detector</p>
	<p>Spanner</p>		<p>Thermometer, Level</p>
	<p>Torque wrench</p>		<p>Flaring Tool Set</p>

Select the best location

Indoor unit

1. Do not have any heat or steam near the unit.
2. Select a place where there are no obstacles in front of the unit.
3. Make sure that condensation drainage can be conveniently routed away.
4. Do not install near a doorway.
5. Ensure the spaces indicated by arrows from the wall, ceiling, fence or other obstacles.
6. Use a Metal Detector or Metal Scanner to locate studs to prevent unnecessary damage to the wall.

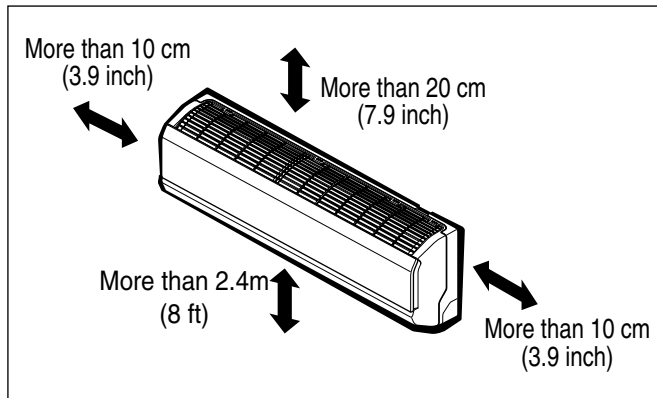

CAUTION: Install the indoor unit on the wall where the height from the floors more than 2.4 m (8 ft).

Outdoor unit

1. If an awning is built over the unit to prevent direct sunlight or rain exposure, make sure that heat radiation from the condenser is not restricted.
2. Ensure that the spaces indicated by arrows around front, back and side of the unit.
3. Do not place animals and plants in the path of the warm air.
4. Take the air conditioner weight into account and select a place where noise and vibration are minimum.
5. Select a place so that the warm air and sound from the air conditioner do not disturb neighbors.

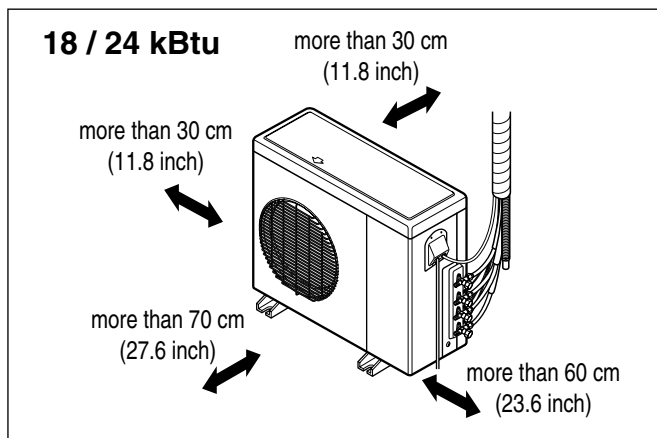

Rooftop Installations:

If the outdoor unit is installed on a roof structure, be sure to level the unit. Ensure the roof structure and anchoring method are adequate for the unit location. Consult local codes regarding rooftop mounting.

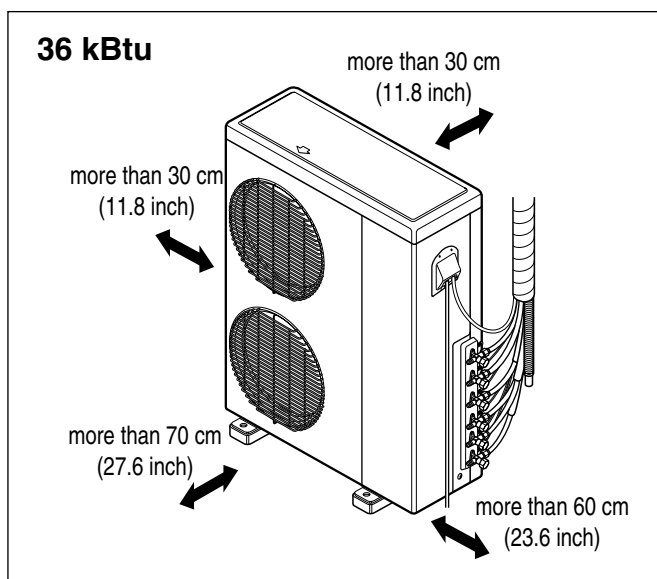

Piping length and elevation

Multi Piping Type

Capacity	Max total length of all pipes (A+B/A+B+C)	Max length of each pipe (A/B/C)	Min length of each pipe (A/B/C)	Max Elevation between each indoor unit and outdoor unit (h1)	Max elevation between indoor units (h2)
18 kBtu	30 m (100 ft)	15 m (50 ft)	3 m (10 ft)	7.5 m (25 ft)	7.5 m (25 ft)
24 kBtu	30 m (100 ft)	15 m (50 ft)	3 m (10 ft)	7.5 m (25 ft)	7.5 m (25 ft)
36 kBtu	45 m (150 ft)	15 m (50 ft)	3 m (10 ft)	7.5 m (25 ft)	7.5 m (25 ft)

Indoor Capacity	Pipe Size			
	Gas	Liquid	Standard Length	Additional Refrigerant
9 kBtu	9.52 mm (3/8")	6.35 mm (1/4")	7.5 m (25 ft)	20 g/m (0.22 oz/ft)
12 kBtu	9.52 mm (3/8")	6.35 mm (1/4")	7.5 m (25 ft)	20 g/m (0.22 oz/ft)

18 / 24 kBtu

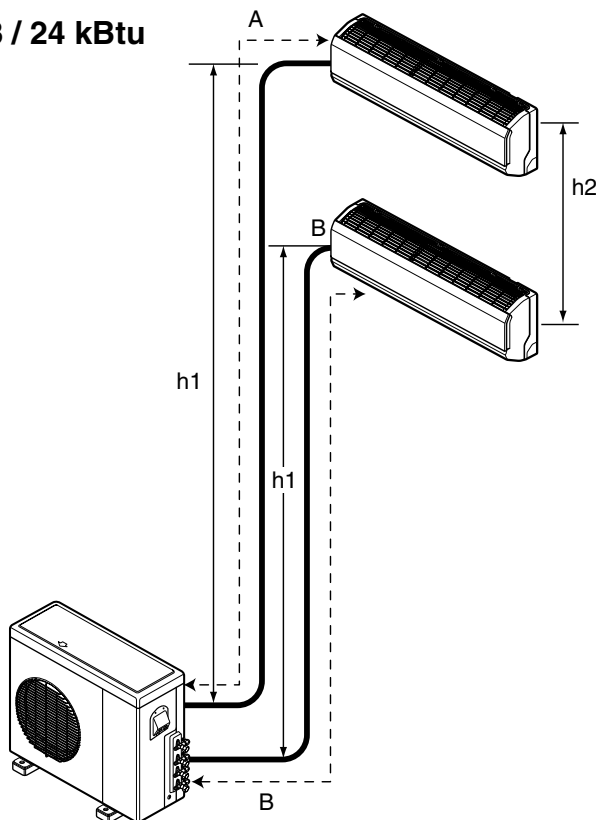

36 kBtu

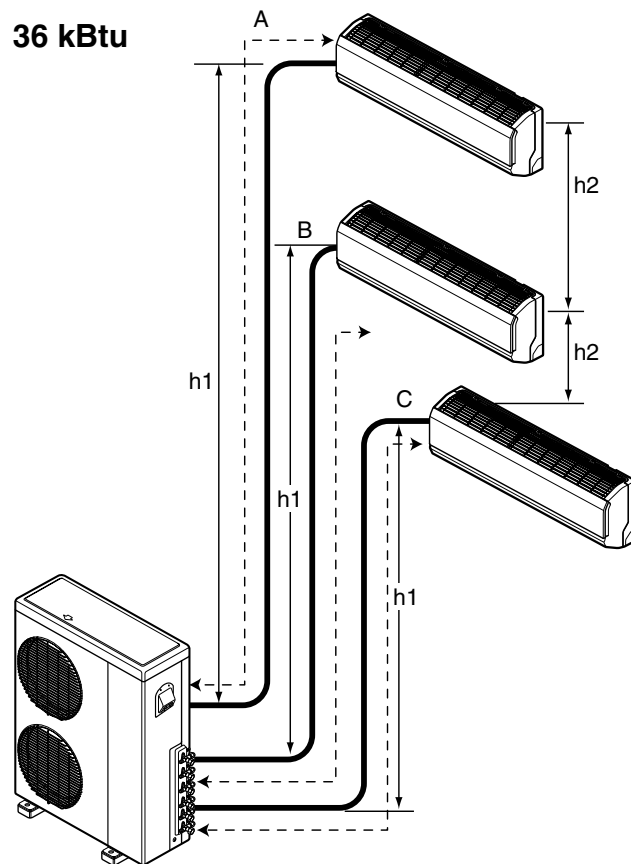

CAUTION: Capacity is based on standard length and maximum allowance length is on the basis of reliability.

Fixing Installation Plate(Standard Type)

The wall you select should be strong and solid enough to prevent vibration

1. Mount the installation plate on the wall with type "A" screws. If mounting the unit on a concrete wall, use anchor bolts.
- Mount the installation plate horizontally by aligning the centerline using a level.

2. Measure the wall and mark the centerline. It is also important to use caution concerning the location of the installation plate-routing of the wiring to power outlets is through the walls typically. Drilling the hole through the wall for piping connections must be done safely.

CHASSIS (Grade)	Distance (mm)			
	A	B	C	D
S4	50	105	59	105
SE	65	110	85	110

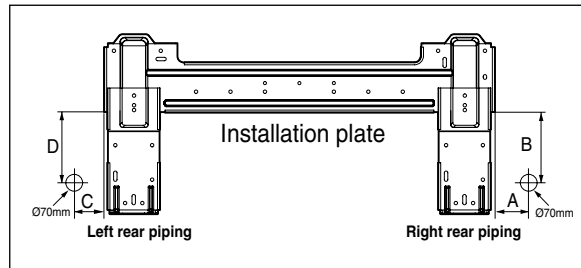
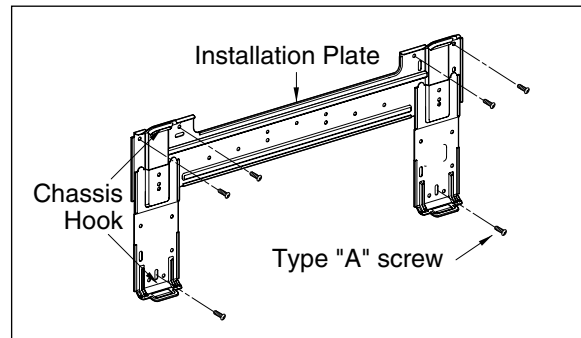

Drill a hole in the wall

- Drill the piping hole with a $\text{Ø } 70 \text{ mm}$ ($\text{Ø } 2.75 \text{ inch}$) hole core drill. Drill the piping hole at either the right or the left with the hole slightly slanted to the outdoor side.

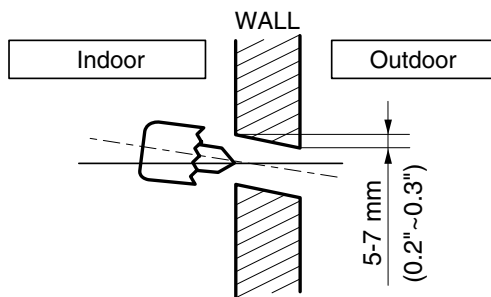

Flaring Work and Connection of Piping

Flaring work

Main cause for gas leakage is due to defect in flaring work. Carry out correct flaring work in the following procedure.

Cut the pipes

1. Use the piping kit accessory or the pipes purchased locally.
2. Measure the distance between the indoor and the outdoor unit.
3. Cut the pipes a little longer than measured distance.
4. Cut the cable 1.5m (5.0ft) longer than the pipe length.

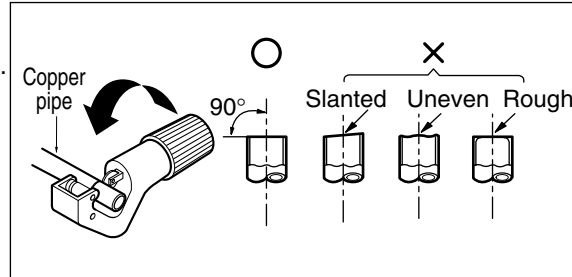

Burrs removal

1. Completely remove all burrs from the cut cross section of pipe/tube.
2. Put the end of the copper tube/pipe in a downward direction as you remove burrs in order to avoid dropping burrs into the tubing.

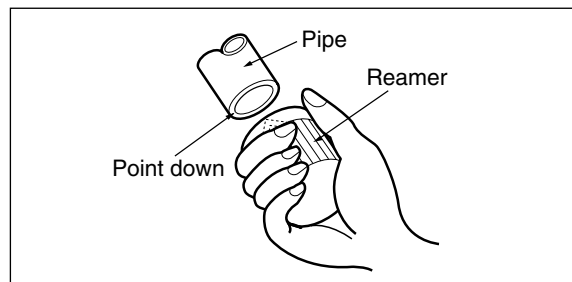

Putting nut on

- Remove flare nuts attached to indoor and outdoor unit, then put them on pipe/tube having completed burr removal. (not possible to put them on after flaring work)

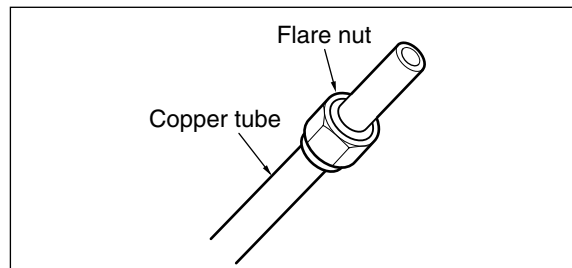

Flaring work

- Carry out flaring work using flaring tool as shown below.
- Firmly hold copper pipe in a Bar in the dimension shown in the table Below.

Outside diameter		A
mm	inch	mm
Ø6.35	1/4	0~0.5
Ø9.52	3/8	0~0.5

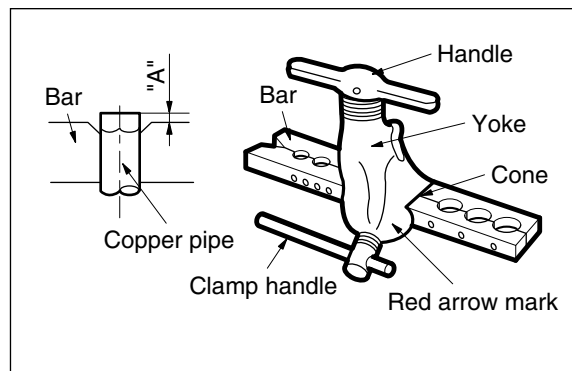

Check

1. Compare the flared work with the figure by.
2. If a flared section is defective, cut it off and do flaring work again.

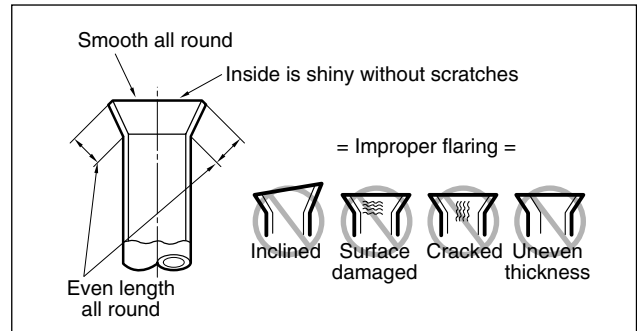

Connecting the Piping

Indoor

1. Prepare the indoor unit's piping and drain hose for installation through the wall.
2. Remove the plastic tubing retainer(see the illustration by) and pull the tubing and drain hose away from chassis.
3. Replace only the plastic tubing holder 1, not the holder 2 in the original position.

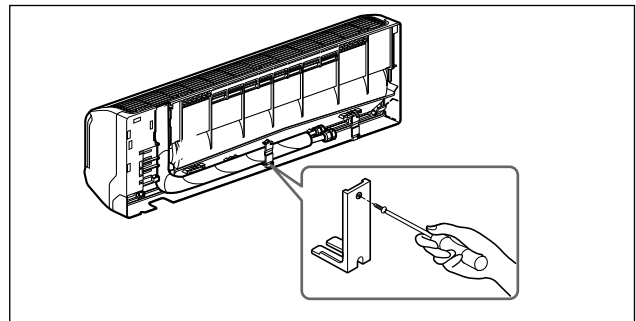

For right rear piping

1. Route the indoor tubing and the drain hose in the direction of rear right.
2. Insert the connecting cable into the indoor unit from the outdoor unit through the piping hole.
 - Do not connect the cable to the indoor unit.
 - Make a small loop with the cable for easy connection later.
3. Tape the tubing, drain hose, and the connecting cable. Be sure that the drain hose is located at the lowest side of the bundle. Locating at the Upper side can cause drain pan to overflow inside the unit.

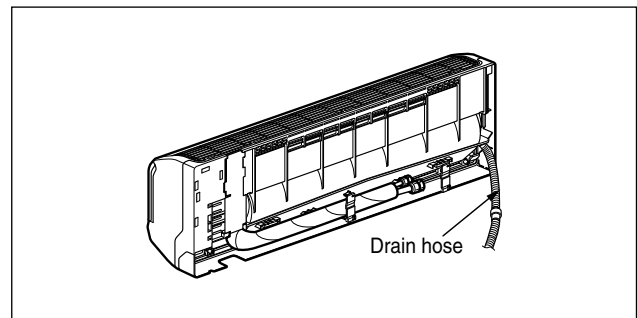

⚠ CAUTION

If the drain hose is routed inside the room, insulate the hose with an insulation material* so that dripping from "sweating"(condensation) will not damage furniture or floors.

*Foamed polyethylene or equivalent is recommended.

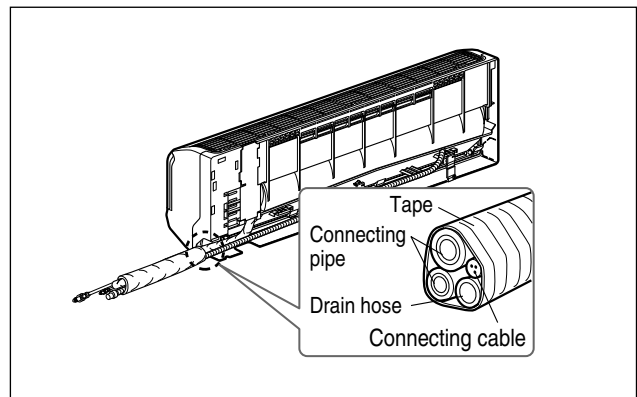

4. Indoor unit installation

Hook the indoor unit onto the upper portion of the installation plate. (Engage the two hooks of the rear top of the indoor unit with the upper edge of the installation plate.) Ensure that the hooks are properly seated on the installation plate by moving it left and right.

Press the lower left and right sides of the unit against the installation plate until the hooks engage into their slots (clicking sound).

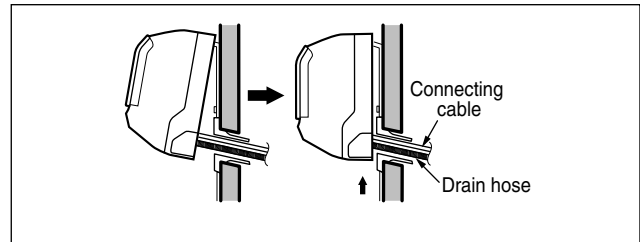

Connecting the piping to the indoor unit and drain hose to drain pipe.

1. Align the center of the pipes and sufficiently tighten the flare nut by hand.
2. Tighten the flare nut with a wrench.

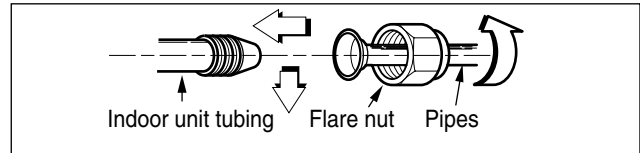

Outside diameter		Torque	
mm	inch	kg·m	lbf.in
Ø6.35	1/4	1.8	156.2
Ø9.52	3/8	4.2	364.5

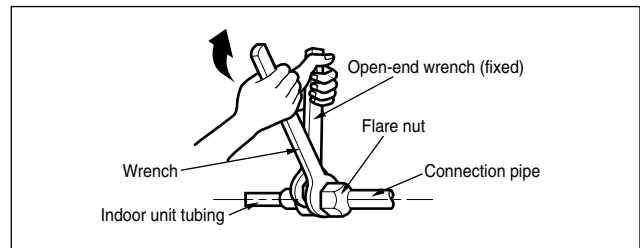

3. When extending the drain hose at the indoor unit, install the drain pipe.

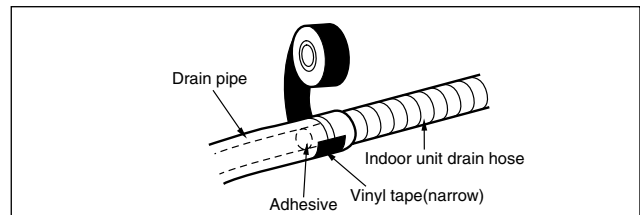

Wrap the insulation material around the connecting portion.

1. Overlap the connection pipe insulation material and the indoor unit pipe insulation material. Bind them together with vinyl tape so that there may be no gap.
2. Wrap the area which accommodates the rear piping housing section with vinyl tape.

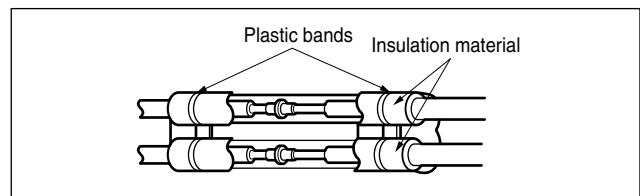

3. Bundle the piping and drain hose together by wrapping them with vinyl tape for enough to cover where they fit into the rear piping housing section.

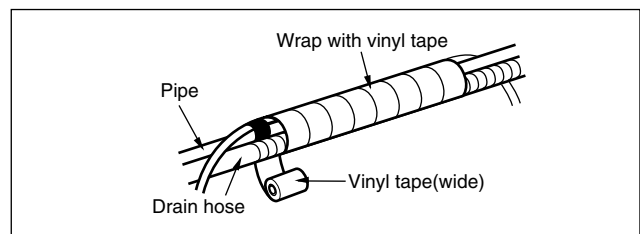
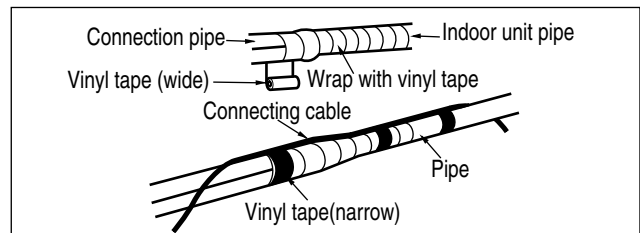

For left rear piping

1. Route the indoor tubing and the drain hose to the required piping hole position.
2. Insert the piping, drain hose, and the connecting cable into the piping hole.
3. Insert the connecting cable into the indoor unit.
 - Don't connect the cable to the indoor unit.
 - Make a small loop with the cable for easy connection later.
4. Tape the drain hose and the connecting cables.

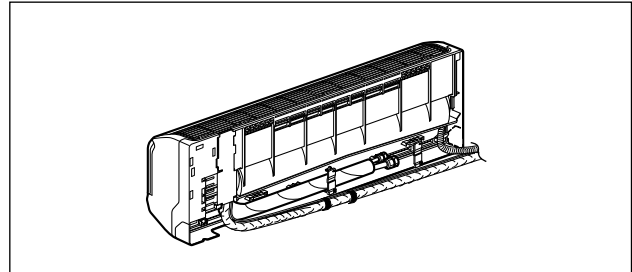
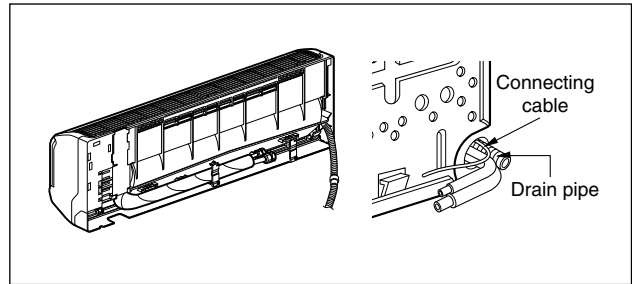

5. Indoor unit installation
 - Hang the indoor unit from the hooks at the top of the installation plate.
 - Insert the spacer etc. between the indoor unit and the installation plate and separate the bottom of the indoor unit from the wall.

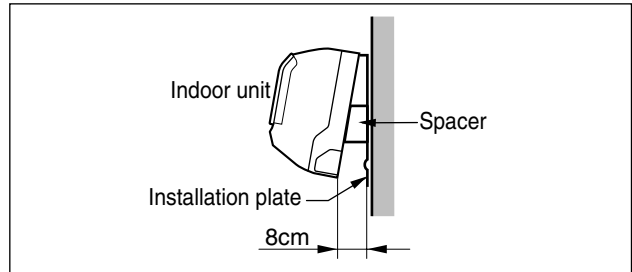

Connecting the piping to the indoor unit and the drain hose to drain pipe.

1. Align the center of the pipes and sufficiently tighten the flare nut by hand.
2. Tighten the flare nut with a wrench.

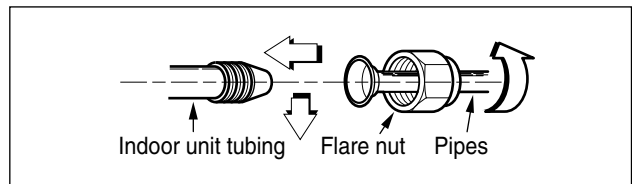

Outside diameter		Torque	
mm	inch	kg·m	lbf.in
Ø6.35	1/4	1.8	156.2
Ø9.52	3/8	4.2	364.5

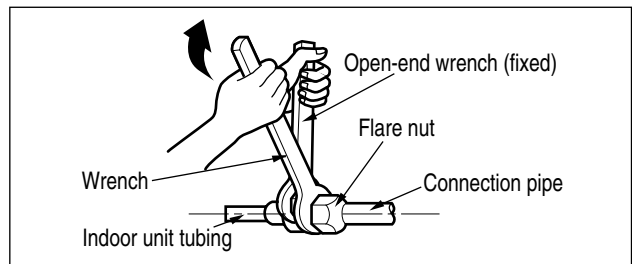

3. When extending the drain hose at the indoor unit, install the drain pipe.

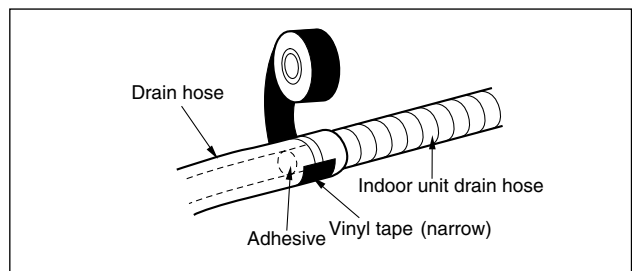

Wrap the insulation material around the connecting portion.

1. Overlap the connection pipe heat insulation and the indoor unit pipe heat insulation material. Bind them together with vinyl tape so that there may be no gap.
2. Wrap the area which accommodates the rear piping housing section with vinyl tape.

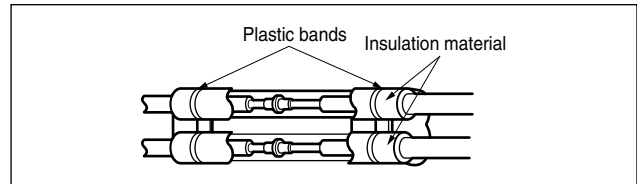

3. Bundle the piping and drain hose together by wrapping them with cloth tape over the range within which they fit into the rear piping housing section.

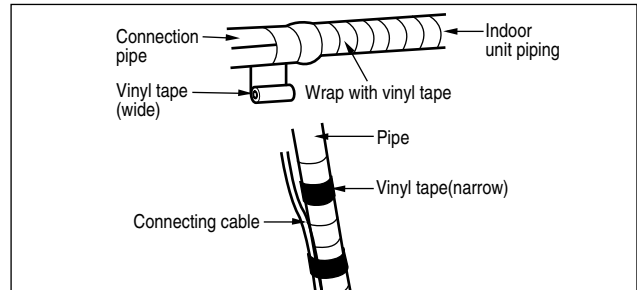

Reroute the pipings and the drain hose across the back of the chassis.

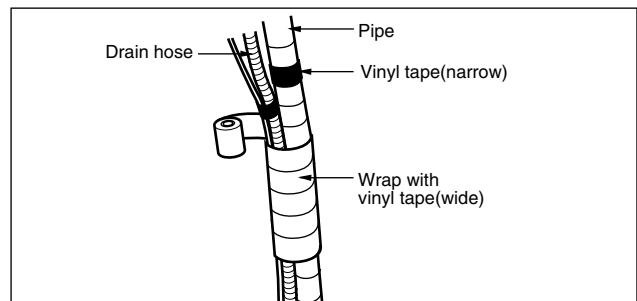

Indoor unit installation

1. Remove the spacer.
2. Ensure that the hooks are properly seated on the installation plate by moving it left and right.
3. Press the lower left and right sides of the unit against the installation plate until the hooks engage into their slots (clicking sound).

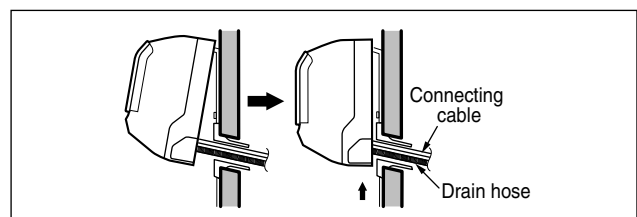
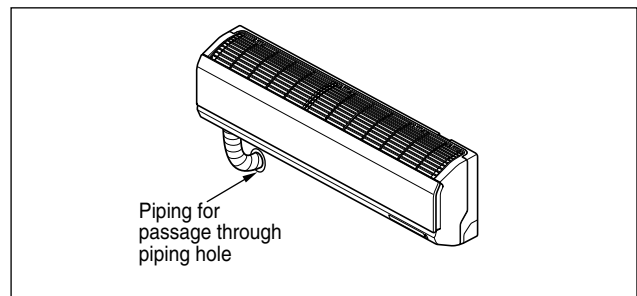

⚠ CAUTION

Installation Information. For left piping. Follow the instruction below.

Good case

- Press on the upper side of clamp and unfold the tubing to downward slowly.

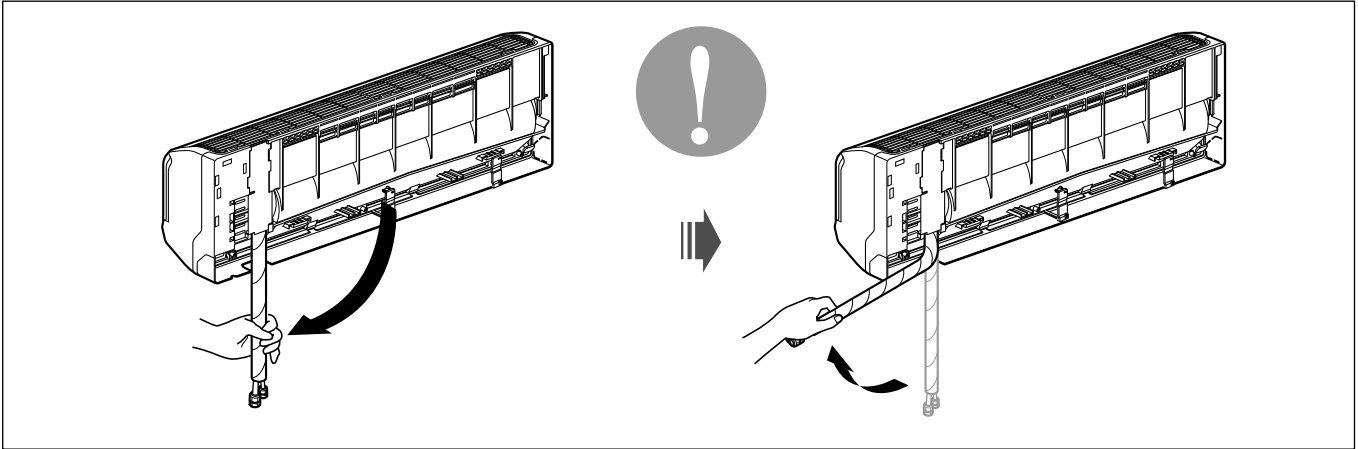

Bad case

- Following bending type from right to left may cause damage to the tubing.

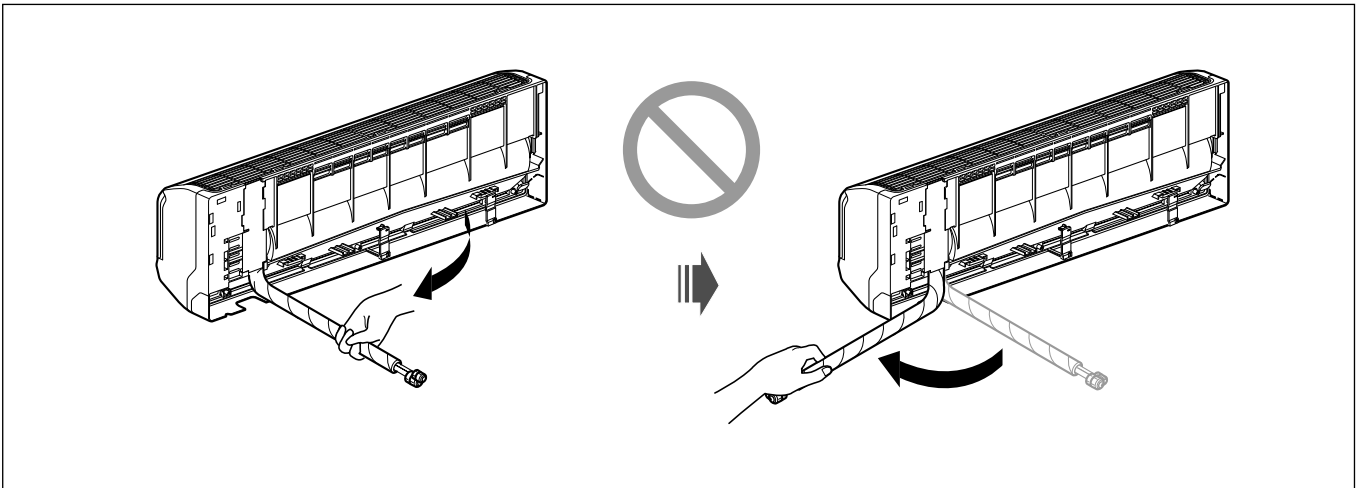

REMOTE CONTROL PREPARATION(OPTIONAL)

HOW TO MOUNT ONTO A WALL

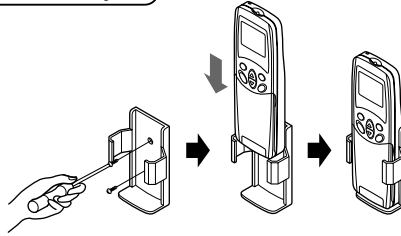

HOW TO INSERT BATTERIES

- 1** Remove the battery cover from the remote controller.
 - Slide the cover according to the arrow direction.
- 2** Insert the two batteries.
 - Be sure that the (+) and (-) directions are correct.
 - Be sure that both batteries are new.
- 3** Re-attach the cover.
 - Slide it back into position.



- Do not use rechargeable batteries, such batteries differ from standard dry cells in shape, dimensions, and performance.
- Remove the batteries from the remote controller if the air conditioner is not going to be used for some long time.

Outdoor

Align the center of the pipings and sufficiently tighten the flare nut by hand.

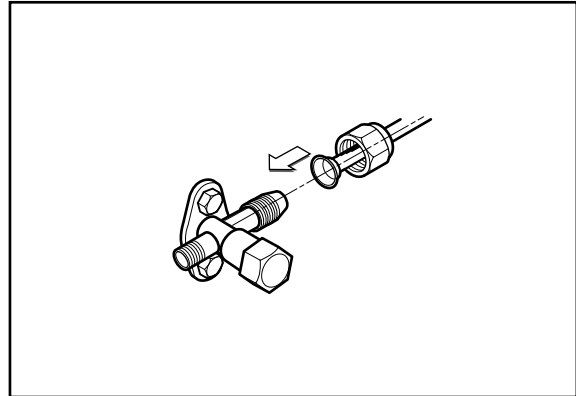

Finally, tighten the flare nut with torque wrench until the wrench clicks.

- When tightening the flare nut with torque wrench, ensure the direction for tightening follows the arrow on the wrench.

Outside diameter		Torque	
mm	inch	kg·m	lbf.in
Ø6.35	1/4	1.8	156.2
Ø9.52	3/8	4.2	364.5

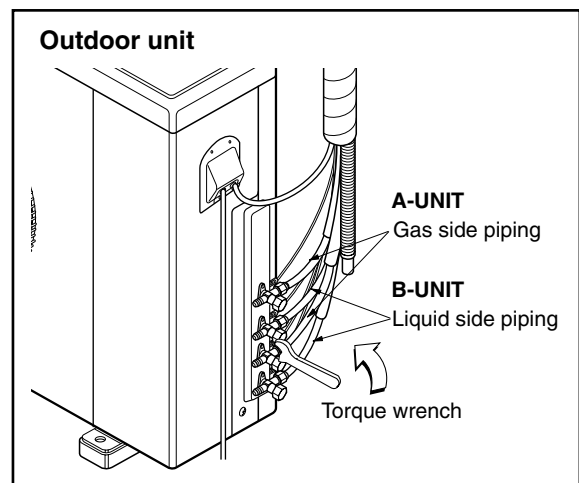

Connecting the Cable between Indoor Unit and Outdoor Unit

Connect the cable to the Indoor unit.

Connect the cable to the indoor unit by connecting the wires to the terminals on the control board individually according to the outdoor unit connection. (Ensure that the color of the wires of the outdoor unit and the terminal No. are the same as those of the indoor unit.)

The earth wire should be longer than the common wires.

The circuit diagram is not subject to change without notice.

When installing, refer to the electrical diagram behind the front panel of Indoor Unit.

The wiring for the outdoor unit can be found on the inside of the Outdoor Unit control cover.



WARNING:

- The circuit diagram is not subject to change without notice.
- Be sure to connect wires according to the wiring diagram.
- Connect the wires firmly, so that not to be pulled out easily.
- Connect the wires according to color codes by referring to the wiring diagram.



WARNING: Provide a circuit breaker between power source and the outdoor unit as shown below.

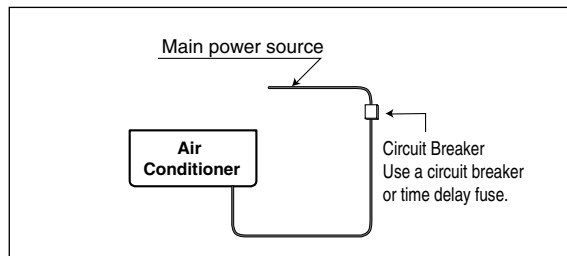

WARNING: The power cord connected to the outdoor unit should be complied with the following specifications (ETL recognized and CSA certified).

18 / 24 kBtu

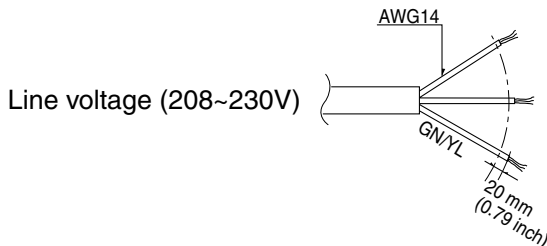

36 kBtu

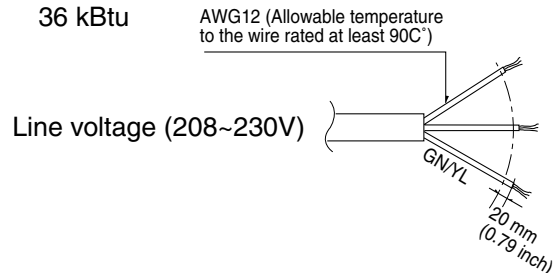

The power connecting cable connected to the indoor and outdoor unit should be complied with the following specifications (ETL recognized and CSA certified).

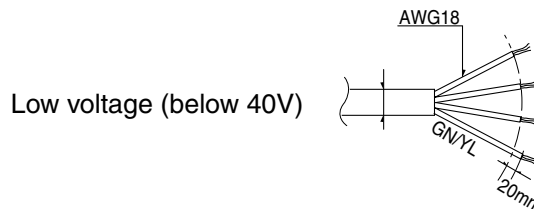

WARNING: When using the separate wire as the power cord, please fix the separate wire into the control box panel by using tie wrap as the fixture.

Connect the cable to the Outdoor unit.

1. Remove the cover control from the unit by loosening the screw.
Connect the wires to the terminals on the control board individually as the following.
2. Secure the cable onto the control board with the holder (clamper).
3. Refix the cover control to the original position with the screw.

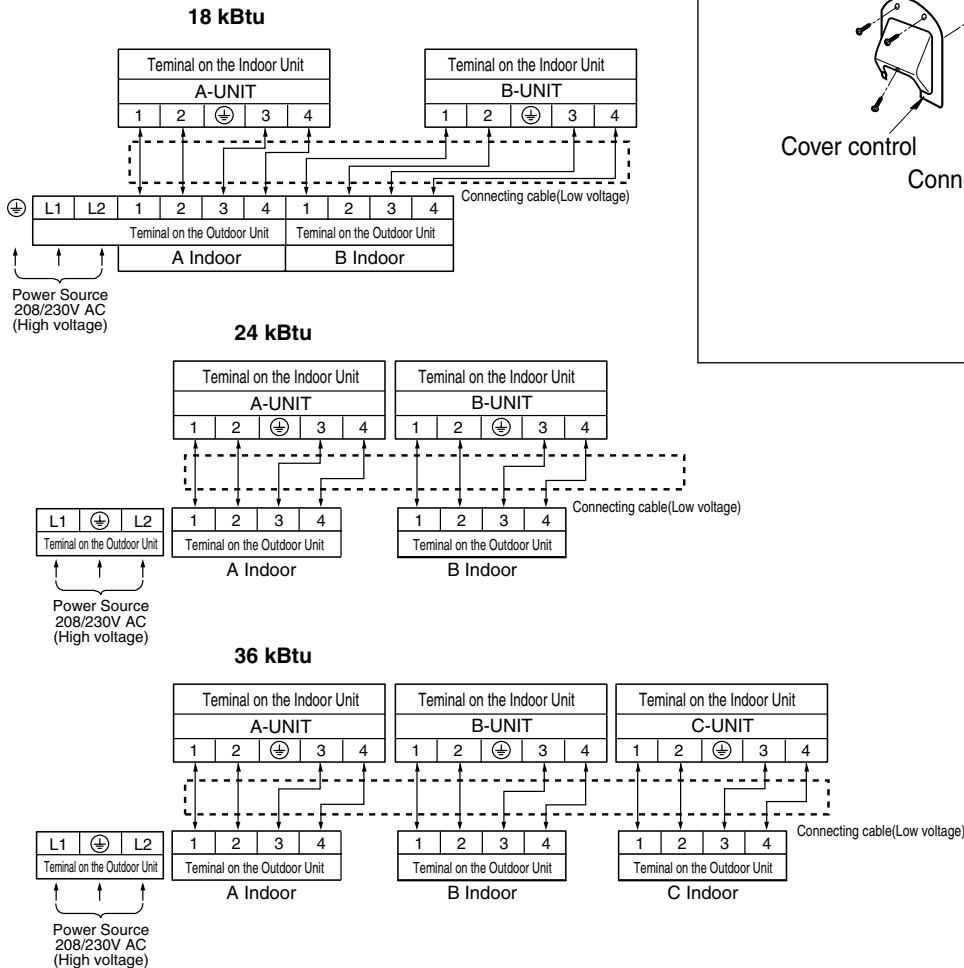
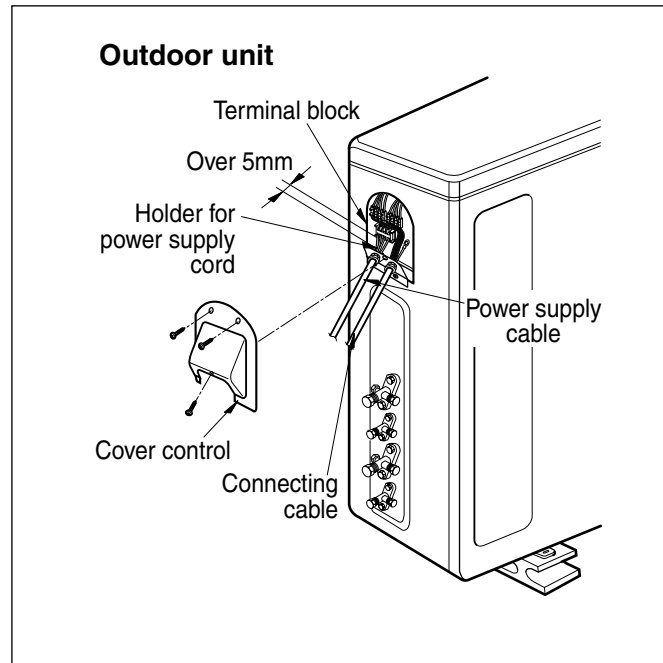

NOTICE :

1. Separately wire the high and low voltage line.
2. Use heat-proof electrical wiring capable of withstanding temperature up to 75°C(167°F).
3. Use outdoor and waterproof connection cable rated more than 300V for the connection between indoor and outdoor unit.
(For example, Type SJOW)



WARNING:

- Be sure to comply with local codes while running the wire from the indoor unit to the outdoor unit (size of wire and wiring method, etc).
- Every wire must be connected firmly.
- No wire should be allowed to touch refrigerant tubing, the compressor or any moving parts.

Connection method of the connecting cable(Example)

- (1) Remove two-caps on the conduit panel.
(for low voltage line)
- (2) Pull out connection cable through conduit.
- (3) After conduit to the panel, fix nut to the opposite side of panel.
- (4) Pass the connection cabel through the hole.
- (5) Properly connect the cable on the terminal block.
- (6) Fix the connection cable with cord clamp provided on the unit not to have strain at the terminal when the connection cable is pulled outside up to a 35 pound weight



WARNING: Loose wiring may cause the terminal to overheat or result in unit malfunction. A fire hazard may also exist. Therefore, be sure all wiring is tightly connected.

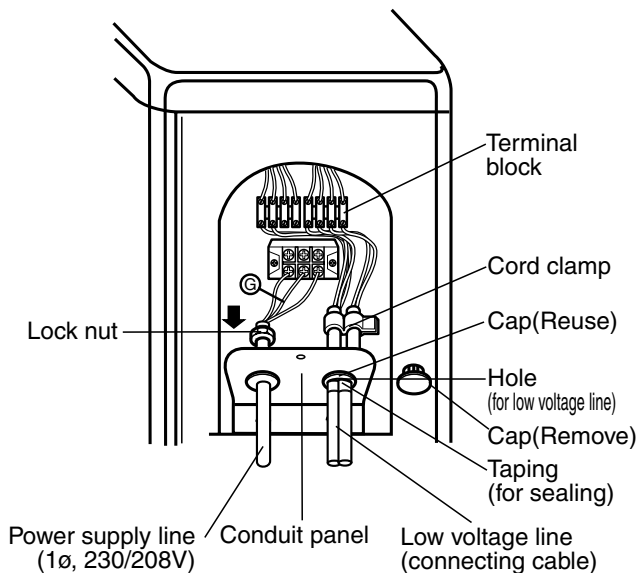

When connecting each power wire to the corresponding terminal, follow instructions "How to connect wiring to the terminals" and fasten the wire tightly with the fixing screw of the terminal plate.

How to connect wiring to the terminals

For strand wiring

- (1) Cut the wire end with a wire cutter or wire-cutting pliers, then strip the insulation to expose the strand wiring about 10mm(3/8").
- (2) Using a screwdriver, remove the terminal screw(s) on the terminal plate.
- (3) Using a round terminal fastener or pliers, securely clamp each stripped wire end with a round terminal.
- (4) Position the round terminal wire, and replace and tighten the terminal screw using a screwdriver.

High voltage

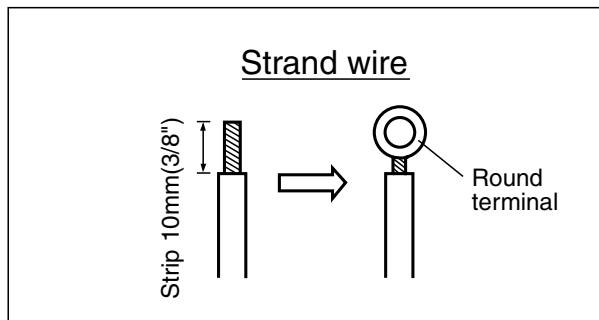

Low voltage

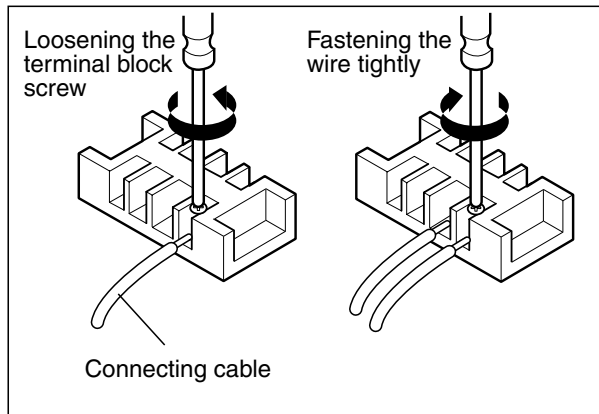

CAUTION: Provide a circuit breaker between power source and the unit as shown below.

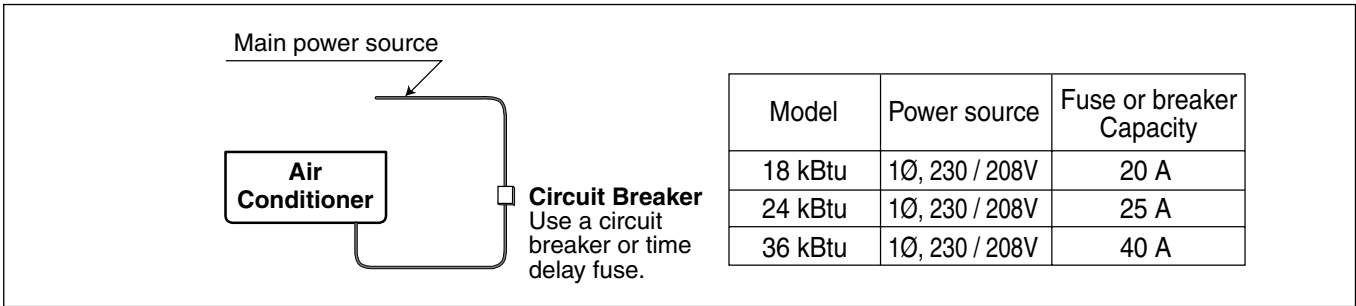

Connect the cable to the indoor unit

1. Connect the wires to the terminals on the control board individually according to the outdoor unit connection.
 - Ensure that the color of the wires of outdoor unit and the terminal No. are the same as those of indoor unit respectively.

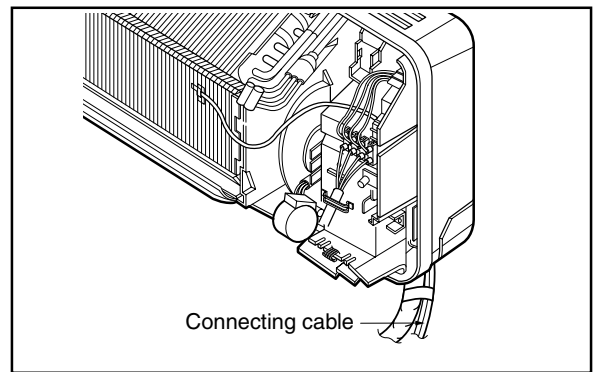

2. Attach the Grille onto the cabinet.
 - Grasp the lower left and right side of the Grille and engage four tabs on the top inside edge of the chassis.
 - Press the Grille toward the chassis until it will be back into place.

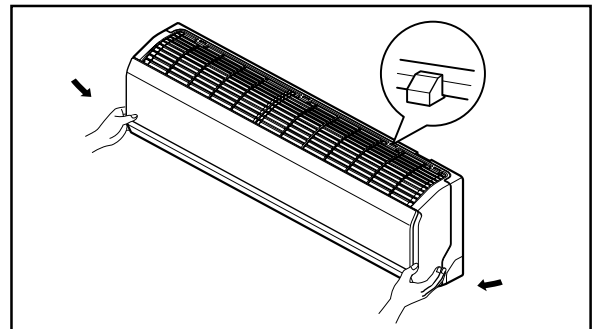

Checking the Drainage, Forming the Pipings and Long Pipe Setting

Checking the drainage

To check the drainage.

1. Pour a glass of water on the evaporator.
2. Ensure the water flows through the drain hose of the indoor unit without any leakage and goes out the drain exit.

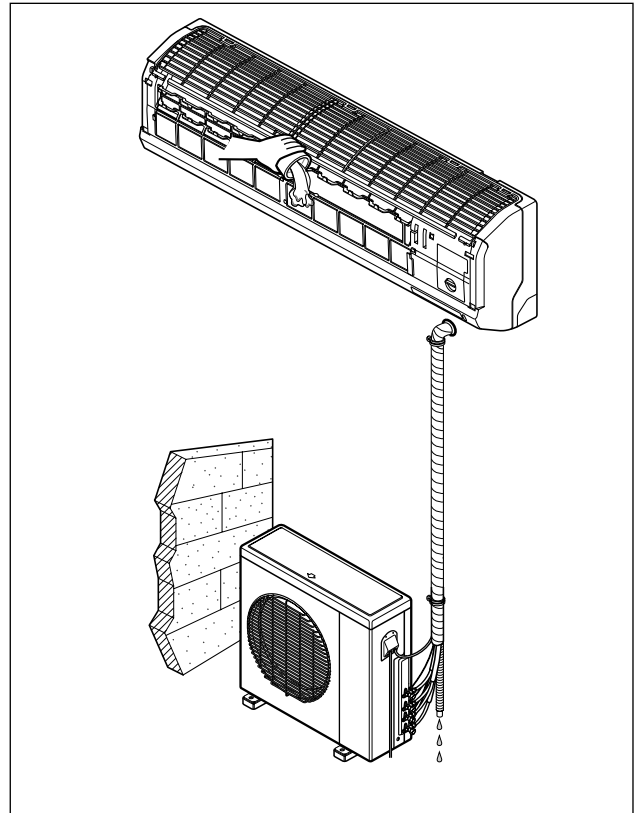

Drain piping

1. The drain hose should point downward for easy drain flow.
2. Do not make drain piping.

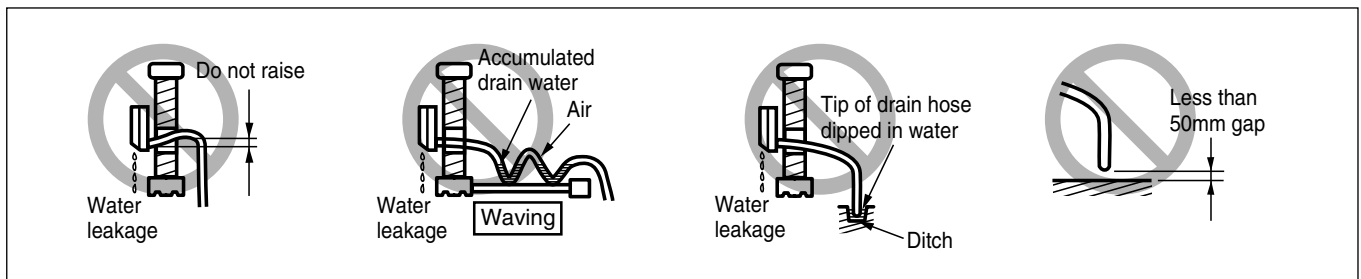
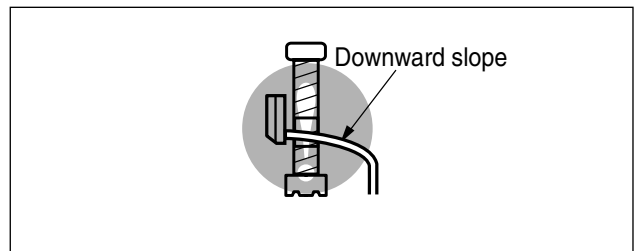

Forming the piping

Form the piping by wrapping the connecting portion of the indoor unit with insulation material and secure it with two kinds of vinyl tape.

- If you want to connect an additional drain hose, the end of the drain outlet should be routed above the ground. Secure the drain hose appropriately.

In cases where the outdoor unit is installed below the indoor unit perform the following.

1. Tape the piping, drain hose and connecting cable from down to up.
2. Secure the tapped piping along the exterior wall using saddle or equivalent.

In cases where the Outdoor unit is installed above the Indoor unit perform the following.

1. Tape the piping and connecting cable from down to up.
2. Secure the taped piping along the exterior wall. Form a trap to prevent water entering the room.
3. Fix the piping onto the wall by saddle or equivalent.

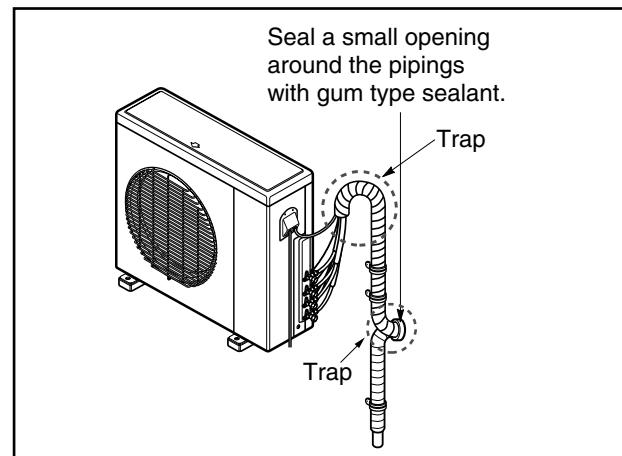
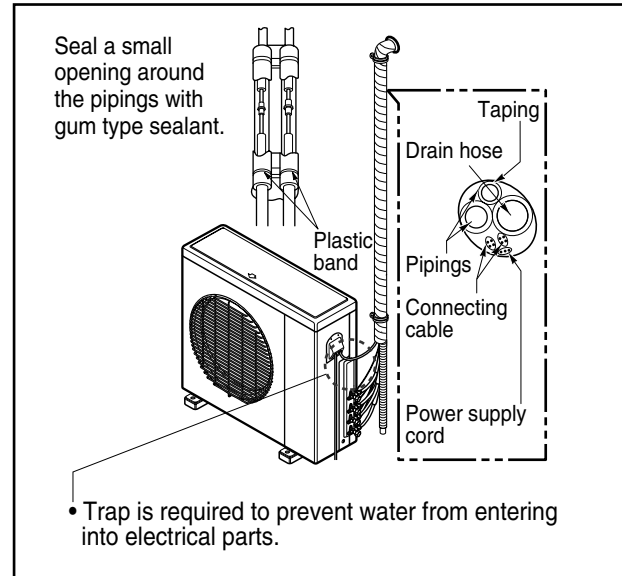

Air Purging and Evacuation

Air and moisture remaining in the refrigerant system have undesirable effects as indicated below.

1. Pressure in the system rises.
2. Operating current rises.
3. Cooling(or heating) efficiency drops.
4. Moisture in the refrigerant circuit may freeze and block capillary tubing.
5. Water may lead to corrosion of parts in the refrigeration system.

Therefore, the indoor/outdoor unit and connecting tube must be checked for leak tight, and vacuumed to remove incondensable gas and moisture in the system.

Checking method

Preparation

- Check that each tube(both liquid and gas side tubes) between the indoor and outdoor units have been properly connected and all wiring for the test run has been completed. Remove the service valve caps from both the gas and the liquid side on the outdoor unit. Check that both the liquid and the gas side service valves on the outdoor unit are kept closed at this stage.

Leakage test

- Connect the manifold valve(with pressure gauges) and dry nitrogen gas cylinder to this service port with charge hoses.

CAUTION: Be sure to use a manifold valve for leak testing.

The high side manifold valve must always be kept closed.

- Pressurize the system to no more than 150 P.S.I.G. with dry nitrogen gas and close the cylinder valve when the gauge reading reached 150 P.S.I.G. Next, test for leaks with liquid soap.

CAUTION: To avoid nitrogen entering the refrigerant system in a liquid state, the top of the cylinder must be higher than its bottom when you pressurize the system. Usually, the cylinder is used in a vertical standing position.

NOTICE : Leakage test should be done for each indoor unit connection set, separately.

1. Do a leakage test of all joints of the tubing(both indoor and outdoor) and both gas and liquid side service valves. Bubbles indicate a leak. Be sure to wipe off the soap with a clean cloth.
2. After the system is found to be free of leaks, relieve the nitrogen pressure by loosening the charge hose connector at the nitrogen cylinder. When the system pressure is reduced to normal, disconnect the hose from the cylinder.

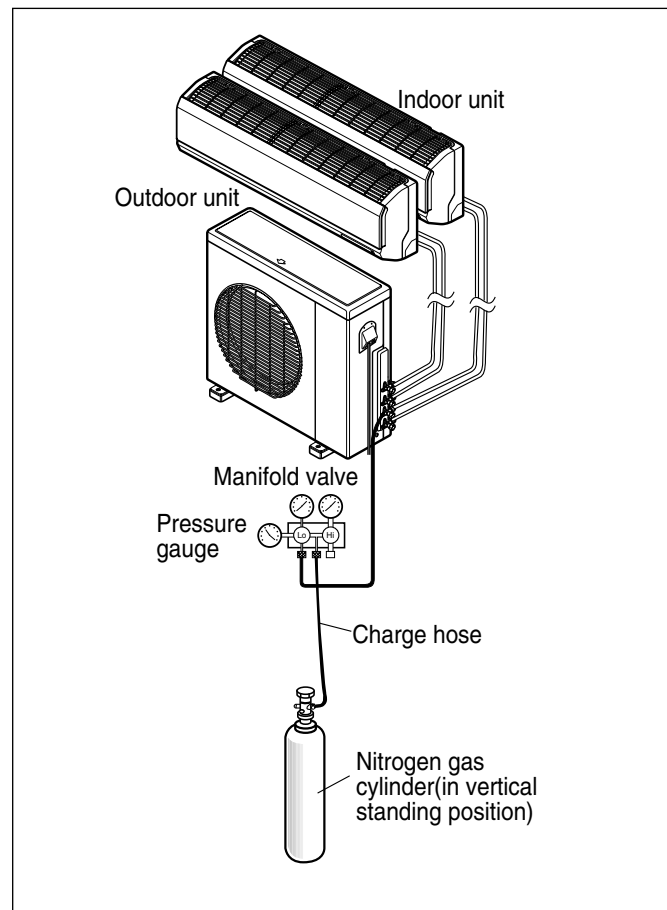

Evacuation

1. Connect the charge hose end described in the preceding steps to the vacuum pump to evacuate the tubing and indoor unit.
Confirm the "Lo" knob of the manifold valve is open. Then, run the vacuum pump.
The operation time for evacuation varies with tubing length and capacity of the pump. The following table shows the time required for evacuation.

Required time for evacuation when 4 CFM vacuum pump is used	
If tubing length is less than 10m (33 ft)	If tubing length is longer than 10m (33 ft)
10 min. or more	15 min. or more

2. When the desired vacuum is reached, close the "Lo" knob of the manifold valve and stop the vacuum pump.

Finishing the job

1. With a service valve wrench, turn the valve stem of liquid side valve counter-clockwise to fully open the valve.
2. Turn the valve stem of gas side valve counter-clockwise to fully open the valve.
3. Loosen the charge hose connected to the gas side service port slightly to release the pressure, then remove the hose.
4. Replace the flare nut and its bonnet on the gas side service port and fasten the flare nut securely with an adjustable wrench. This process is very important to prevent leakage from the system.
5. Replace the valve caps at both gas and liquid side service valves and fasten them tight.

This completes air purging with a vacuum pump.

The air conditioner is now ready for test running.

NOTICE

: Repeat evacuation procedure for each indoor unit.

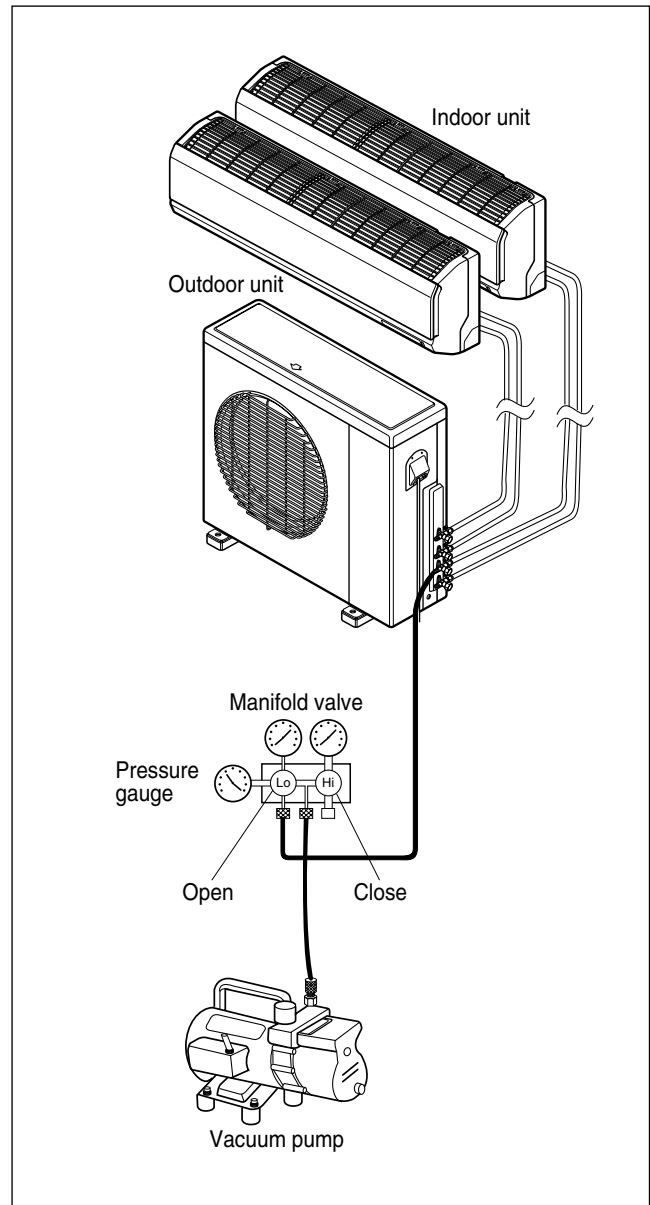

Charging

- Each outdoor unit is factory charged (nameplate charge) for the evaporator as well as a 7.5m(25ft) line set for each indoor line.
Any time total line set is used either shorter or longer than the nominal 22.5m(75ft: for tri-zone) line set length the refrigerant charge has to be adjusted.
- Whether the line set is made shorter or longer you must adjust the charge based on how many ft of tubing are either added or removed based on 20g(0.22oz) of R-410A per meter(foot).

Capacity (Btu/h)	Max total length of all pipes (A+B)	Max length of each pipe (A/B)	Min length of each pipe (A/B)	Max Elevation between each indoor unit and outdoor unit (h1)	Max elevation between indoor units (h2)	Additional Refrigerant
18k	30m(100ft)	15m(50ft)	5m(16ft)	7.5m(25ft)	7.5m(25ft)	20g/m(0.22oz/ft)
24k	30m(100ft)	15m(50ft)	3m(10ft)	7.5m(25ft)	7.5m(25ft)	20g/m(0.22oz/ft)

Capacity (Btu/h)	Max total length of all pipes (A+B+C)	Max length of each pipe (A/B/C)	Min length of each pipe (A/B/C)	Max Elevation between each indoor unit and outdoor unit (h1)	Max elevation between indoor units (h2)	Additional Refrigerant
36k	45m(150ft)	15m(50ft)	3m(10ft)	7.5m(25ft)	7.5m(25ft)	20g/m(0.22oz/ft)

Example: A 80ft line set is used for tril - zone 5 additional ft X 0.22 ounces per foot= add 1.1 ounces of R-410A

Important:

If you are ever uncertain of the unit charge, reclaim, evacuate and weigh in the correct charge using the unit nameplate charge adjusting for line sets longer or shorter than 7.5m(25ft) for each indoor unit. Unit is critically charged.

Test Running

Split Type

1. Check that all tubing and wiring have been properly connected.
2. Check that the gas and liquid side service valves are fully open.

1) Prepare remote controller

- ❶ Remove the battery cover by pulling it according to the arrow direction.
- ❷ Insert new batteries making sure that the (+) and (-) of battery are installed correctly.
- ❸ Reattach the cover by pushing it back into position.

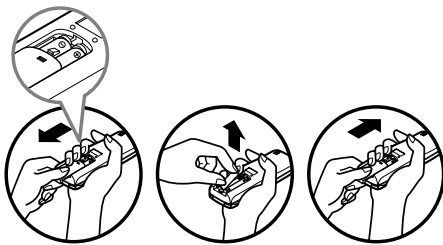

NOTE:

- Use 2 AAA(1.5volt) batteries. Do not use rechargeable batteries.
- Remove the batteries from the remote controller if the system is not going to be used for a long time.

2) Precautions in test run

- The initial power supply must provide at least 90% of the rated voltage. Otherwise, the air conditioner should not be operated.
- For test run, carry out the cooling operation firstly even during heating season. If heating operation is carried out firstly, it leads to the trouble of compressor. Then attention must be paid.
- Carry out the test run more than 5 minutes without fail. (Test run will be cancelled 18 minutes later automatically)
- The test run is started by pressing timer cancel button five times continuously. (Room type)
- To cancel the test run, press any button.

3) Settlement of outdoor unit

- Anchor the outdoor unit with a bolt and nut(ø10mm) tightly and horizontally on a concrete or rigid mount.
- When installing on the wall, roof or rooftop, anchor the mounting base securely with a nail or wire assuming the influence of wind and earthquake.
- In the case when the vibration of the unit is conveyed to the hose, secure the unit with an anti-vibration rubber.

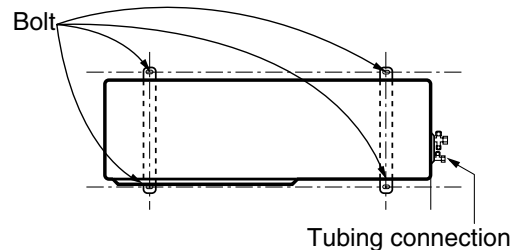

4) Evaluation of the performance

Operate unit for 15~20 minutes, then check the system refrigerant charge:

1. Measure the pressure of the gas side service valve.
2. Measure the temperature of the intake and discharge of air.
3. Ensure the difference between the intake temperature and the discharge is more than 8°C(14.4°F) (Cooling) or reversely (Heating).

Refrigerant	Outside ambient TEMP.	The pressure of the gas side service valve.
R-410A	35°C (95°F)	8.5~9.5kg/cm ² G(120~135 P.S.I.G.)

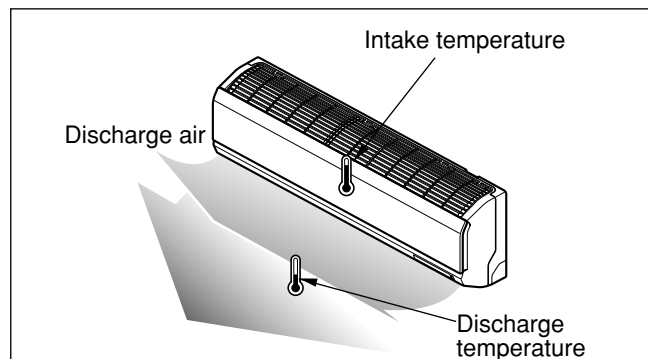

Operation

Function of control

1. MAIN UNIT FUNCTION

• DISPLAY

Operation Indicator

- On while in appliance operation, off while in appliance pause
- Flashing while in disconnection or short in Thermistor (3 sec off / 0.5 sec on)

Sleep Timer Indicator

- On while in sleep timer mode, off when sleep timer cancel or appliance operation pause

Timer Indicator

- On while in timer mode (on/off), off when timer mode is completed or canceled

Defrost Indicator

- Off except when hot start during heating mode operation or while in defrost control

■ Cooling Mode Operation

- When the intake air temperature reaches 0.5°C(0.9°F) below the setting temp, the compressor and the outdoor fan stop.
- When it reaches 0.5°C(0.9°F) above the setting temp, they start to operate again.

Compressor ON Temp	↪ Setting Temp+0.5°C(0.9°F)
Compressor OFF Temp	↪ Setting Temp-0.5°C(0.9°F)
- While in compressor running, operating with the airflow speed set by the remote control. While compressor is off fan operates at low speed regardless of the setting.

■ Soft Dry Operation Mode

- When the dehumidification operation input by the remote control is received, the intake air temperature is detected and the setting temp is automatically set according to the intake air temperature.

26°C(78.8°F) ≤ Intake Air Temp	↪ 25°C(77°F)
24°C(75.2°F) ≤ Intake Intake Air Temp < 26°C(78.8°F)	↪ Intake Air Temp - 1°C(30.2°F)
18°C(64.4°F) ≤ Intake Intake Air Temp < 24°C(75.2°F)	↪ Intake Air Temp - 0.5°C(31.1°F)
Intake Air Temp < 18°C(64.4°F)	↪ 18°C(64.4°F)
- While compressor off, the indoor fan repeats low airflow speed and stop.
- While the intake air temp is between compressor on temp. and compressor off temp., 10-min dehumidification operation and 4-min compressor off repeat.

Compressor ON Temp.	↪ Setting Temp + 0.5°C(0.9°F)
Compressor OFF Temp.	↪ Setting Temp - 0.5°C(0.9°F)
- In 10-min dehumidification operation, the indoor fan operates with the low airflow speed.

■ Heating Mode Operation

- When the intake air temp reaches +3°C(37.4°F)...above the setting temp, the compressor is turned off. When below the setting temp, the compressor is turned on.

Compressor ON Temp.	↪ Setting Temp.
Compressor OFF Temp.	↪ Setting Temp. + 3°C(37.4°F)
- While compressor on, the indoor fan is off when the indoor pipe temp. is below 20°C(68°F), when above 27°C(80.6°F) , it operates with the low or setting speed. When the indoor pipe temp is between 20°C(68°F) and

2) Fuzzy Operation for Dehumidification

- According to the setting temperature selected by Fuzzy rule, when the intake air temp is 0.5°C(0.9°F) or more below the setting temp, the compressor is turned off. When 0.5°C(0.9°F) or more above the setting temp, the compressor is turned on.

Compressor ON Temp	⊃ Setting Temp + 0.5°C(0.9°F)
Compressor OFF Temp	⊃ Setting Temp+0.5°C(0.9°F)
- At the beginning of Fuzzy mode operation, the setting temperature is automatically selected according to the intake air temp at that time.

26°C(78.8°F) ≤ Intake Air Temp	⊃ 25°C(77°F)
24°C(75.2°F) ≤ Intake Air Temp < 26°C(78.8°F)	⊃ Intake Air Temp+1°C(1.8°F)
22°C(71.6°F) ≤ Intake Air Temp < 24°C(75.2°F)	⊃ Intake Air Temp+0.5°C(0.9°F)
18°C(64.4°F) ≤ Intake Air Temp < 22°C(71.6°F)	⊃ Intake Air Temp
Intake Air Temp < 18°C(64.4°F)	⊃ 18°C(64.4°F)
- When the Fuzzy key (Temperature Control key) is input after the initial setting temperature is selected, the Fuzzy key value and the intake air temperature at that time are compared to select the setting temperature automatically according to the Fuzzy rule.
- While in Fuzzy operation, the airflow speed of the indoor fan repeats the low airflow speed or pause as in dehumidification operation.

3) Fuzzy Operation for Heating

- According to the setting temperature selected by Fuzzy rule, when the intake air temp is 3°C(37.4°F) or more above the setting temp, the compressor is turned off. When below the setting temp, the compressor is turned on.

Compressor ON Temp	⊃ Setting Temp
Compressor OFF Temp	⊃ Setting Temp + 3°C(5.4°F)
- At the beginning of Fuzzy mode operation, the setting temperature is automatically selected according to the intake air temp at that time.

20°C(68°F) ≤ Intake Air Temp	⊃ Intake Air Temp + 0.5°C(0.9°F)
Intake Air Temp < 20°C(68°F)	⊃ 20°C(68°F)
- When the Fuzzy key (Temperature Control key) is input after the initial setting temperature is selected, the Fuzzy key value and the intake air temperature at that time are compared to select the setting temperature automatically according to the Fuzzy rule.
- While in Fuzzy operation, the airflow speed of the indoor fan is set to the high or the medium according to the intake air temperature and the setting temperature.

■ Airflow Speed Selection

- The airflow speed of the indoor fan is set to high, medium, low, or power (auto) by the input of the airflow speed selection key on the remote control.

■ On-Timer Operation

- When the set time is reached after the time is input by the remote control, the appliance starts to operate.
 - The timer LED is on when the on-timer is input. It is off when the time set by the timer is reached.
 - If the appliance is operating at the time set by the timer, the operation continues.
- While in Fuzzy operation, the airflow speed of the indoor fan is automatically selected according to the temperature.

■ Off-Timer Operation

- When the set time is reached after the time is input by the remote control, the appliance stops operating.
- The timer LED is on when the off-timer is input. It is off when the time set by the timer is reached.

- If the appliance is on pause at the time set by the timer, the pause continues.

■ Off-Timer <=> On-Timer Operation

- When the set time is reached after the on/off time is input by the remote control, the on/off-timer operation is carried out according to the set time.

■ Sleep Timer Operation

- When the sleep time is reached after <1,2,3,4,5,6,7,0(cancel) hr> is input by the remote control while in appliance operation, the operation of the appliance stops.
- While the appliance is on pause, the sleep timer mode cannot be input.
- While in cooling mode operation, 30 min later since the start of the sleep timer, the setting temperature increases by 1°C(33.8°F). After another 30 min elapse, it increases by 1°C(1.8°F) again.
- When the sleep timer mode is input while in cooling cycle mode, the airflow speed of the indoor fan is set to the low.
- When the sleep timer mode is input while in heating cycle mode, the airflow speed of the indoor fan is set to the medium.

■ Chaos Swing Mode

- By the Chaos Swing key input, the upper/lower vane automatically operates with the Chaos Swing or they are fixed to the desired direction.
- While in Chaos Swing mode, the angles of cooling and heating cycle operations are different.

■ Chaos Natural Wind Mode

- When the Chaos Natural Wind mode is selected and then operated, the high, medium, or low speed of the airflow mode is operated for 2~15 sec. randomly by the Chaos Simulation.

■ Jet Cool Mode Operation

- While in heating mode or Fuzzy operation, the Jet Cool key cannot be input. When it is input while in the other mode operation (cooling, dehumidification, ventilation), the Jet Cool mode is operated.
- In the Jet Cool mode, the indoor fan is operated at super-high speed for 30 min at cooling mode operation.
- In the Jet Cool mode operation, the room temperature is controlled to the setting temperature, 18°C(64.4°F).
- When the sleep timer mode is input while in the Jet Cool mode operation, the Jet Cool mode has the priority.
- When the Jet Cool key is input, the upper/lower vanes are reset to those of the initial cooling mode and then operated in order that the air outflow could reach further.

■ Auto Restarting Operation

- When the power is restored after a sudden power failure while in appliance operation, the mode before the power failure is kept on the memory and the appliance automatically operates in the mode on the memory.

■ Forced Operation

- To operate the appliance by force in case that the remote control is lost, the forced operation selection switch is on the main unit of the appliance to operate the appliance in the standard conditions.
- When the power is supplied while the slide switch is on the forced operation position, or when the slide switch position is switched to the Auto Restarting (or test operation) position or switched from the remote control position to the forced operation position while the power is on, the forced operation is carried out.
- When the slide switch position is switched from the forced operation position to the Auto Restarting position or the remote control position, the forced operation is canceled and the appliance stops operating.
- In the forced operation mode, the indoor fan is operated at low speed for around 15 sec and then the operation condition is set according to the intake air temperature as follows.
 - 24°C(43.2°F) ≤ Intake Air Temp ⇨ Cooling Mode Operation, 22°C(39.6°F), High Speed
 - 21°C(37.8°F) ≤ Intake Air Temp < 24°C(43.2°F) ⇨ Dehumidification Operation, 23°C(41.4°F), High Speed
 - Intake Air Temp < 21°C(37.8°F) ⇨ Heating Mode Operation, 24°C(43.2°F), High Speed

■ Buzzer Sounding Operation

- When the appliance-operation key is input by the remote control, the short "beep-beep-" sounds.
- When the appliance-pause key is input by the remote control, the long "beep—" sounds.

Function of Indoor Unit

Split Type Indoor Unit

Operation ON/OFF by Remote controller

Sensing the Room Temperature

- Room temperature sensor. (THERMISTOR)

Room temperature control

- Maintains the room temperature in accordance with the Setting Temp.

Starting Current Control

- Indoor fan is delayed for 5 seconds at the starting.

Time Delay Safety Control

- Restarting is delayed for approx. 3 minutes.

Indoor Fan Speed Control

- High, Med, Low, Chaos, Jet Cool

Operation indication Lamps (LED)

- Ⓛ **On/Off** : Lights up during the system operation.
- ☆ **Sleep Mode** : Lights up during Sleep Mode Auto operation.
- ⌚ **Timer** : Lights up during Timer operation.
- * **Defrost Mode** : Lights up during Defrost Mode or Hot Start operation (Heat pump model only)
- 🌀 **Outdoor unit operation** : Lights up during outdoor unit operation.(Cooling model only)

- Desire temperature indicator** For cooling,dehumidification,heating modes it display Destired temperature
- | | |
|---|-----------------------|
| • Cooling : 18°C~30°C(64°F~86°F) | • AI : Auto Operation |
| • Dehumidification : 18°C~30°C(64°F~86°F) | • Po : Jet Cool |
| • Heating : 16~30°C(60°F~86°F) | • Lo : Test Mode |

Soft Dry Operation Mode

- Intermittent operation of fan at low speed.

Sleep Mode Auto Control

- The fan is switched to low(Cooling), med(Heating) speed.
- The unit will be stopped after 1, 2, 3, 4, 5, 6, 7 hours.

Natural Air Control by CHAOS Logic

- The fan is switched to intermittent or irregular operation
- The fan speed is automatically switched from high to low speed.

* Airflow Direction Control

- The louver can be set at the desired position or swing up and down automatically.(Model base)

Deice (defrost) control (Heating)

- Both the indoor and outdoor fan stops during deicing.
- Hot start after deice ends.

Hot-start Control (Heating)

- The indoor fan stops until the evaporator piping temperature will be reached at 27°C(80.6°F).

"Wall Mounted Type is standard"

* Functions is dependent on model type.

Function of Outdoor Unit

Outdoor Unit

Operating Step

- Compressor step varies considering condition such as room temp, outdoor temp, operating room number, Temp gap between room temp and set temp and so on.

LEV Control

- LEV pulse is modulated to keep constant superheat or subcooling.

Out door Fan Control

- Outdoor fan operates at High or Off to respond to the load condition.

R/Valve Control(Heating Model Only)

- Convert R/Valve to change cooling to heating, heating to cooling.

Defrost Function

- After 45 min heating operation, check the defrost condition and if outdoor pipe temp is below -5°C(23°F) and released from deice operation in case outdoor pipe temp is over 12°C(53.6°F) or 9 min cooling mode.
- To deice outdoor heat exchanger in low temp condtion, convert operating mode from heating to cooling mode.

Oil Return System

- In single(one) comp operation duration, another comp will operate for 30 seconds every 1 hours.

Comp Overload Protection

- To protect comp from being overload, protector will turn off the comp.

High Pressure Protction

- If cycle pressure is too high(around 36.7 kgf/cm²), it will turn off comp A

Remote Control Operation

The Remote Controller transmits the signals to the system.

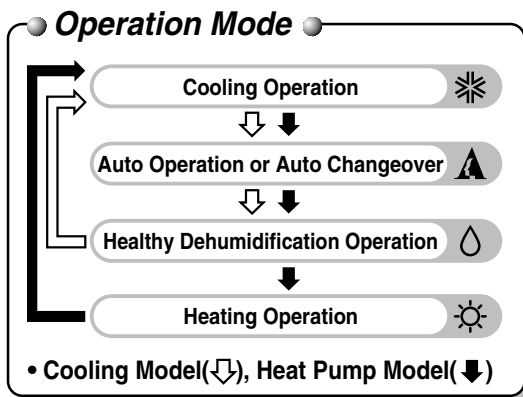
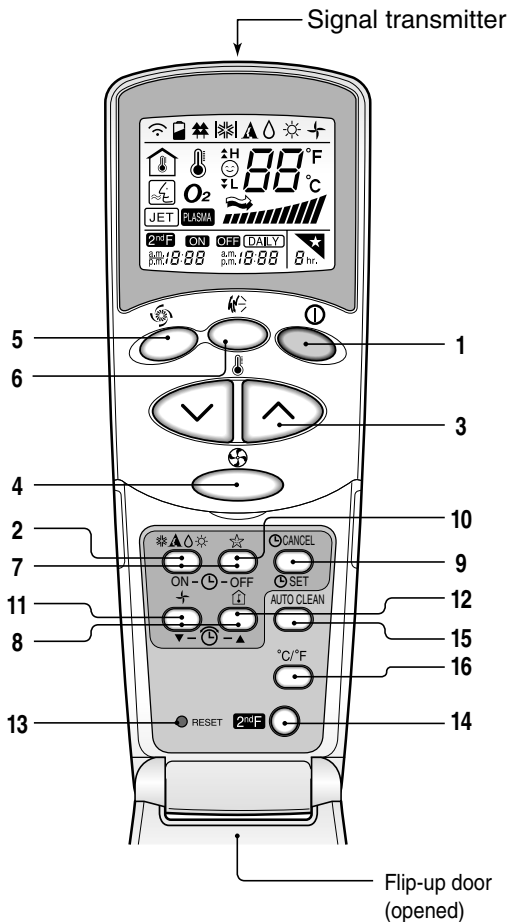

1. START/STOP BUTTON

Operation starts when this button is pressed and stops when the button is pressed again.



2. OPERATION MODE SELECTION BUTTON

Used to select the operation mode.

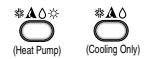

3. ROOM TEMPERATURE SETTING BUTTONS

Used to select the room temperature.



4. INDOOR FAN SPEED SELECTOR

Used to select fan speed in four steps low, medium, high and CHAOS.



5. JET COOL

Used to start or stop the speed cooling/heating. (speed cooling/heating operates super high fan speed.)



6. CHAOS SWING BUTTON

Used to stop or start louver movement and set the desired up/down airflow direction.



7. ON/OFF TIMER BUTTONS

Used to set the time of starting and stopping operation.

8. TIME SETTING BUTTONS

Used to adjust the time.

9. TIMER SET/CANCEL BUTTON

Used to set the timer when the desired time is obtained and to cancel the Timer operation.

10. SLEEP MODE AUTO BUTTON

Used to set Sleep Mode Auto operation.

11. AIR CIRCULATION BUTTON

Used to circulate the room air without cooling or heating.

12. ROOM TEMPERATURE CHECKING BUTTON

Used to check the room temperature.

13. RESET BUTTON

Used prior to resetting time.

14. 2nd F Button

Used prior to using modes printed in blue at the bottom of buttons.

15. AUTO CLEAN

Used to set Auto Clean mode.

16. °C TO °F SWITCHING BUTTON

Used to switch temperature reading from Centigrade to Fahrenheit.

Disassembly

Indoor Unit

Split Type Indoor Unit

▲ WARNING

Disconnect the unit from power supply before making any checks.

Be sure the power switch is set to "OFF".

To remove the Grille from the Chassis.

- Set the up-and-down air discharge louver to open position (horizontally) by finger pressure.
- Remove the securing screws.
- To remove the Grille, pull the lower left and right side of the grille toward you (slightly tilted) and lift it straight upward.

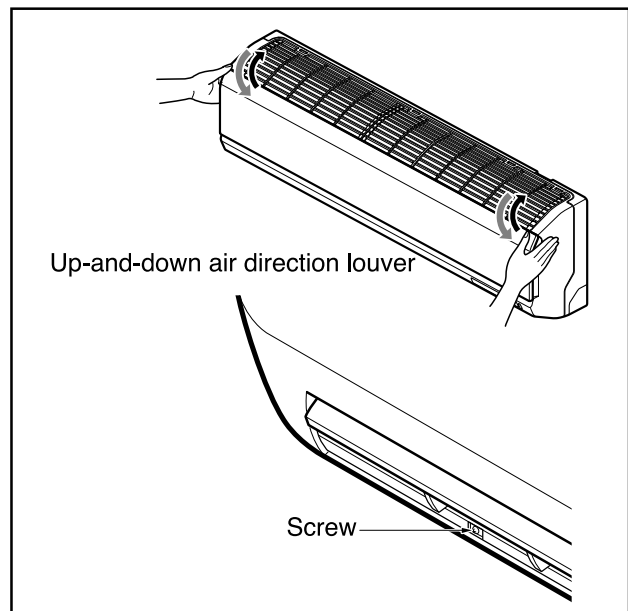

1. Before removing the control box, be sure to take out the wire screwed at the other end.

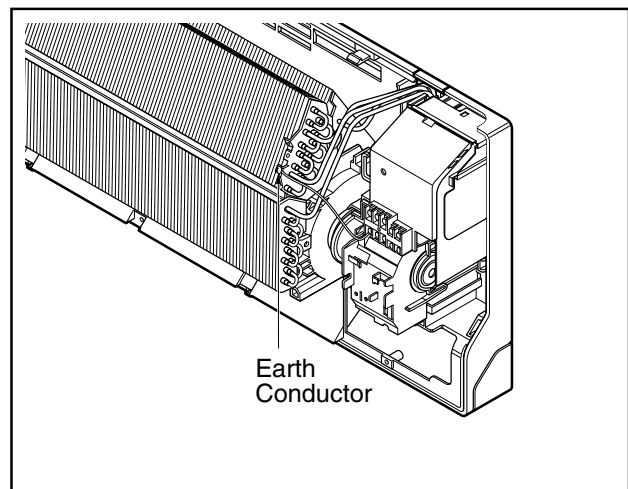

2. To remove the Control Box.

- Remove securing screws.
- Pull the control box out from the chassis carefully.

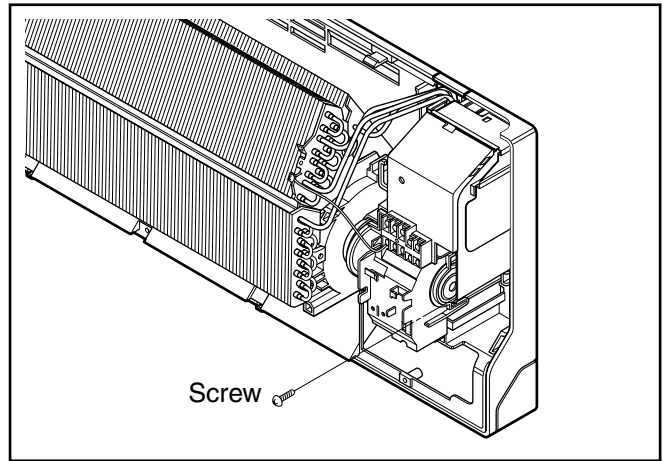

3. To remove the Discharge Grille.

- Unhook the discharge grille and pull the discharge grille out from the chassis carefully.

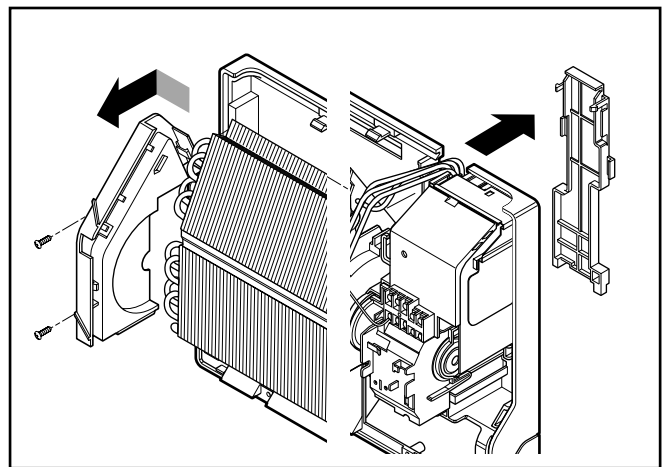

4. To remove the Evaporator.

- Remove 3 screws securing the evaporator(at the left 2EA in the Eva Holder, at the right 1EA).

▲ CAUTION

- When repair, do not damage the Caution label.

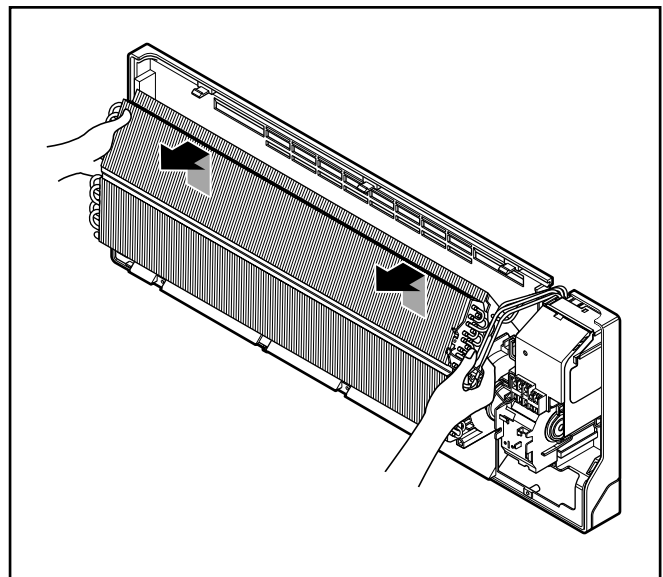

- Unhook the tab on the right inside of the chassis at the same time, slightly pull the evaporator toward you until the tab is clear of the slot.

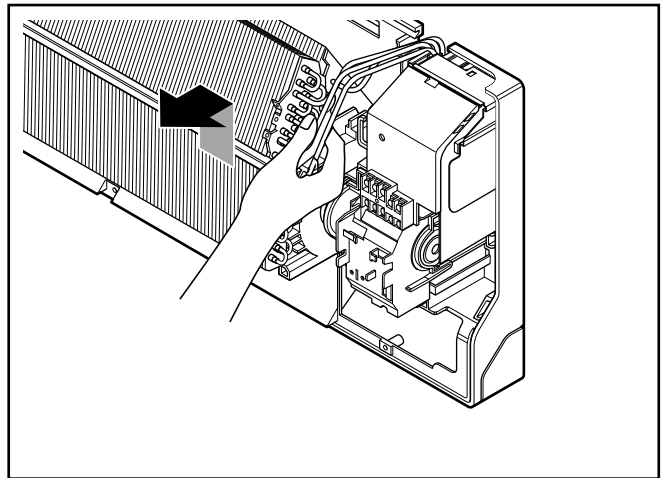

5. To remove the Motor Cover

- Remove 2 securing screw.
- Pull the motor cover out from the chassis carefully.

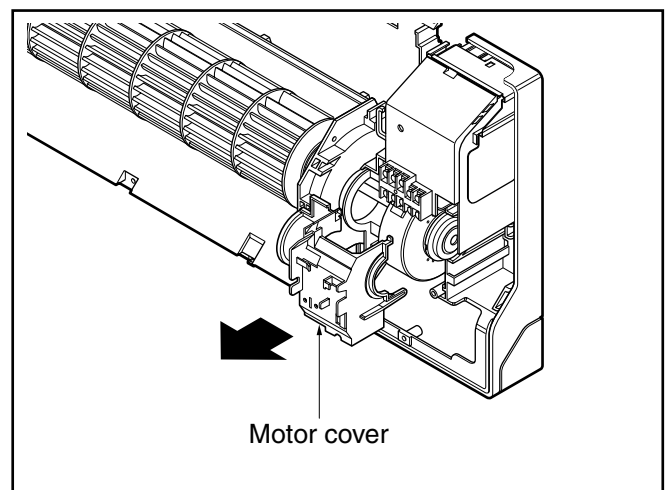

6. To remove the Cross-Flow Fan

- Loosen the screw securing the cross-flow fan to the fan motor (do not remove).
- Lift up the right side of the cross-flow fan and the fan motor, separate the fan motor from the cross-flow fan.

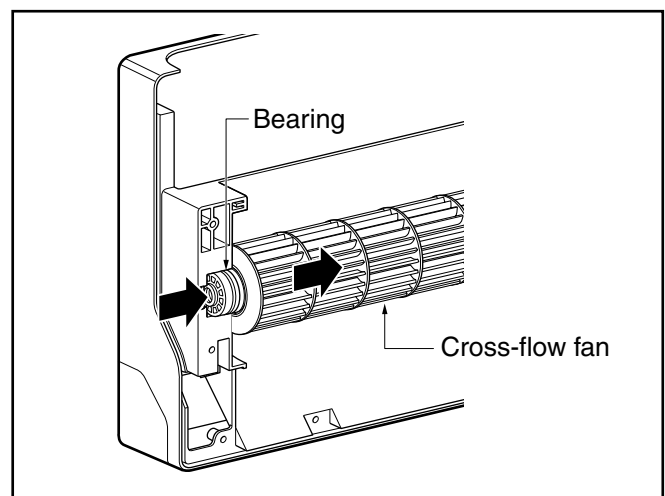

- Remove the left end of the cross-flow fan from the self-aligning bearing.

2. Outdoor Unit

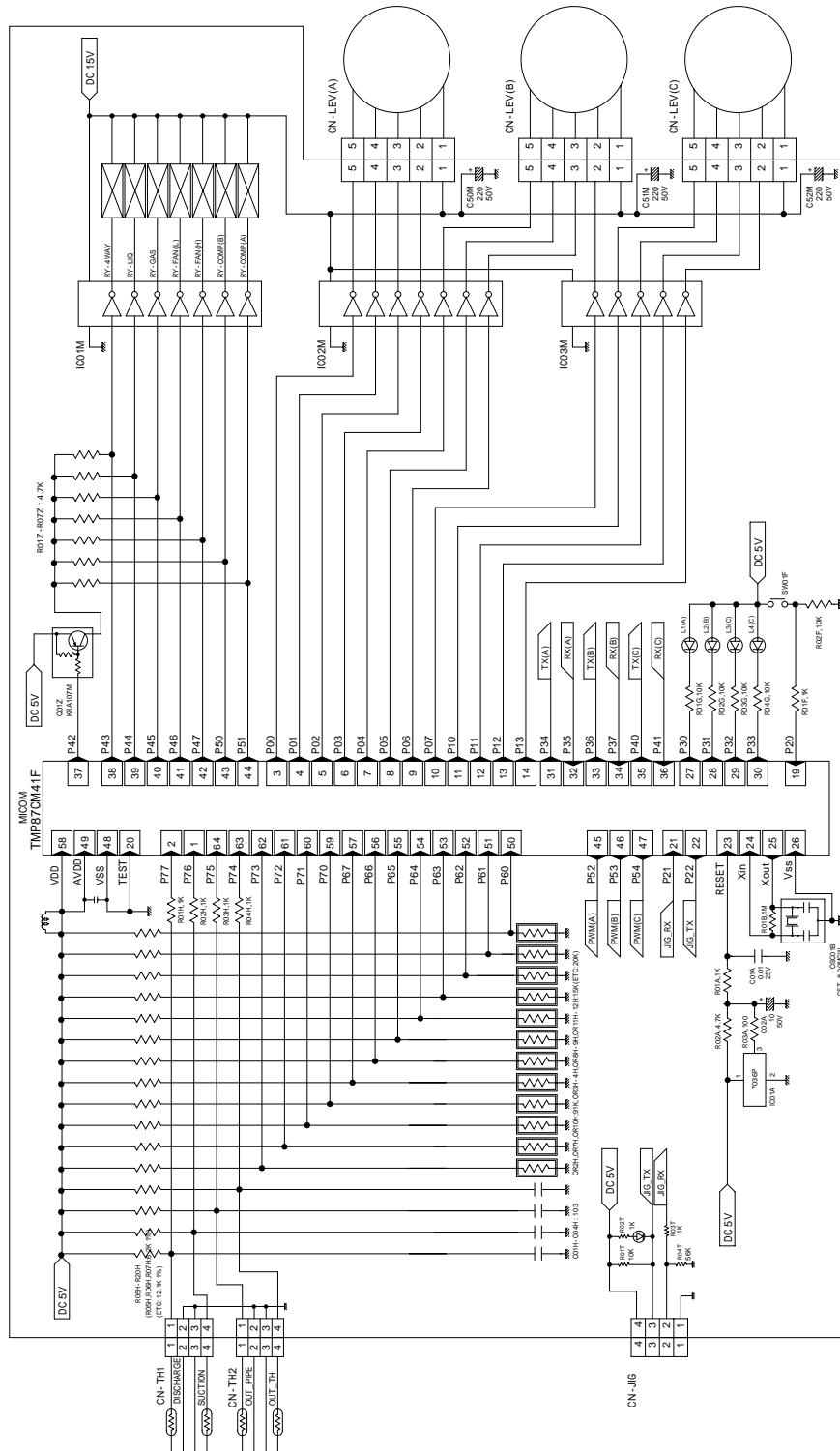

Schematic Diagram

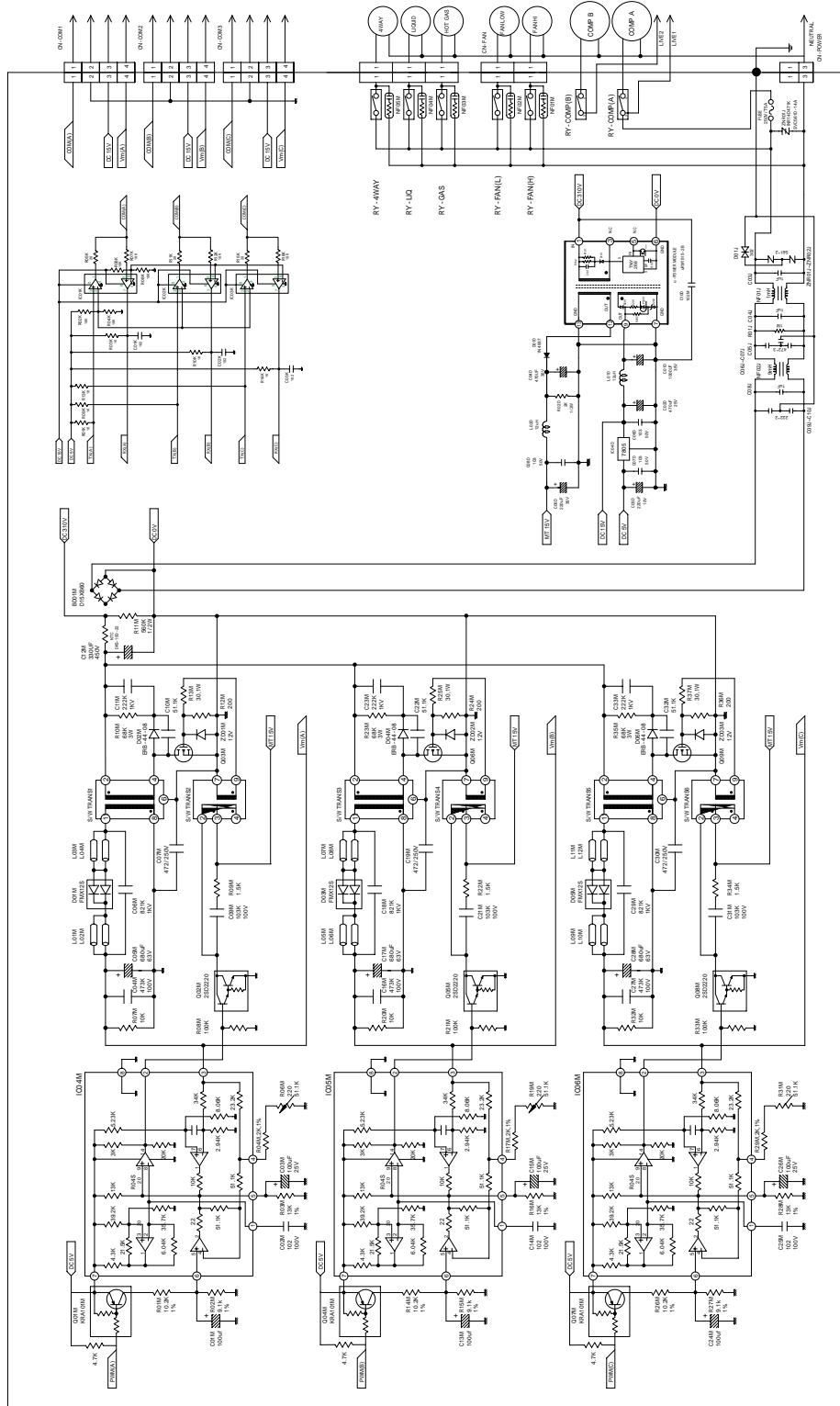

Wiring Diagram

1. Indoor Unit

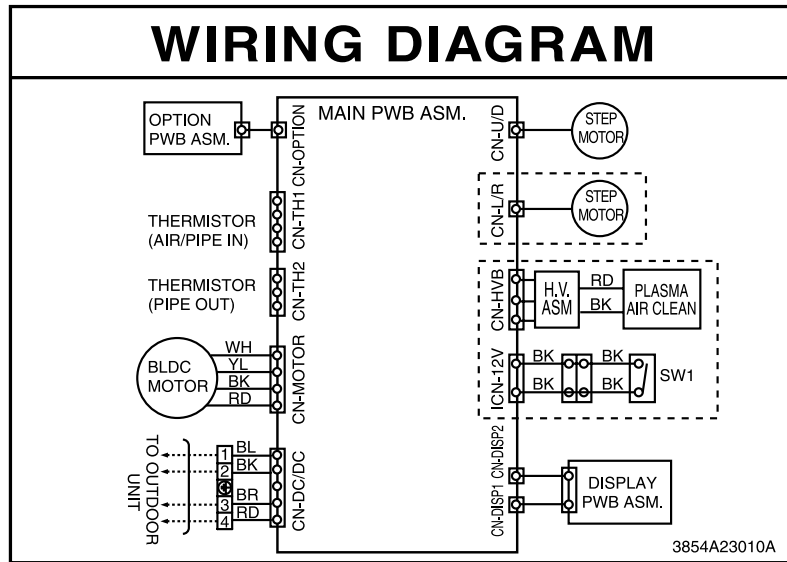

2. Outdoor Unit

1)A-MMH18FA-1

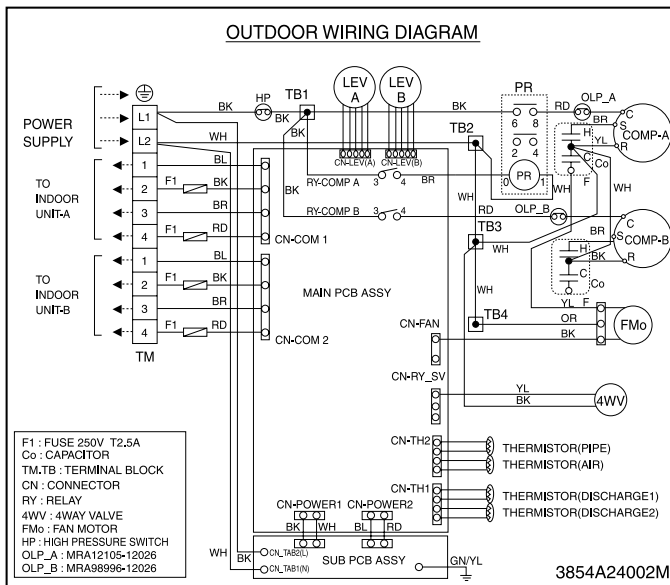

2) A-MMC24FA-1

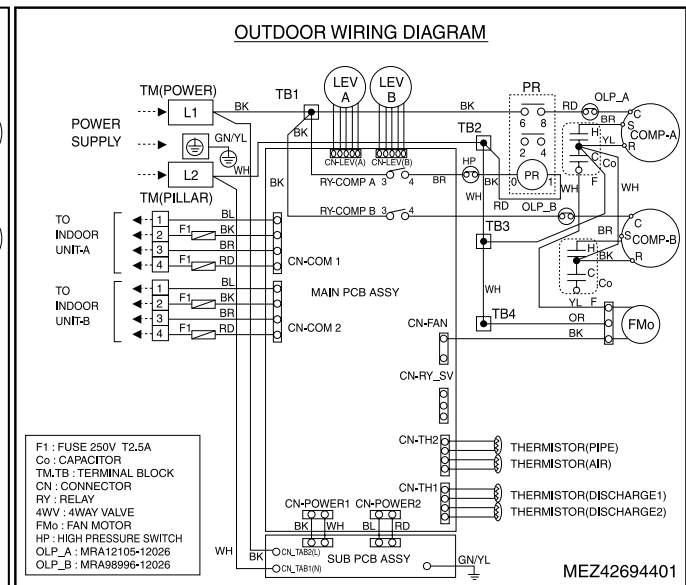

3) A-MMH24FA-1

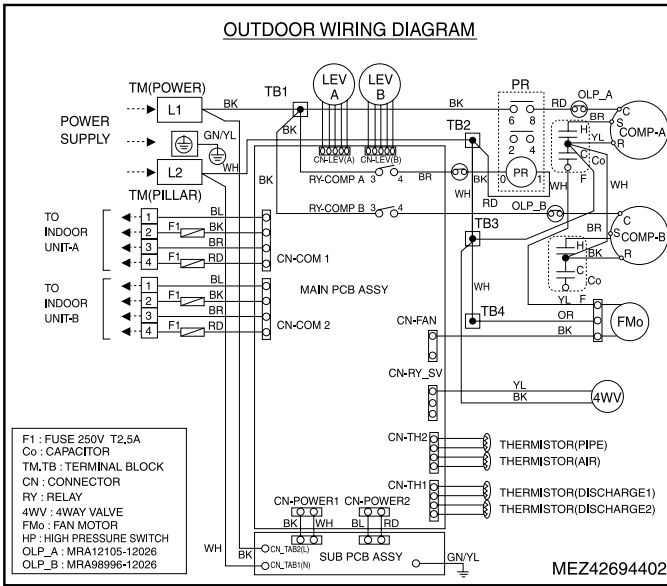

4) A-MMC36FA-1

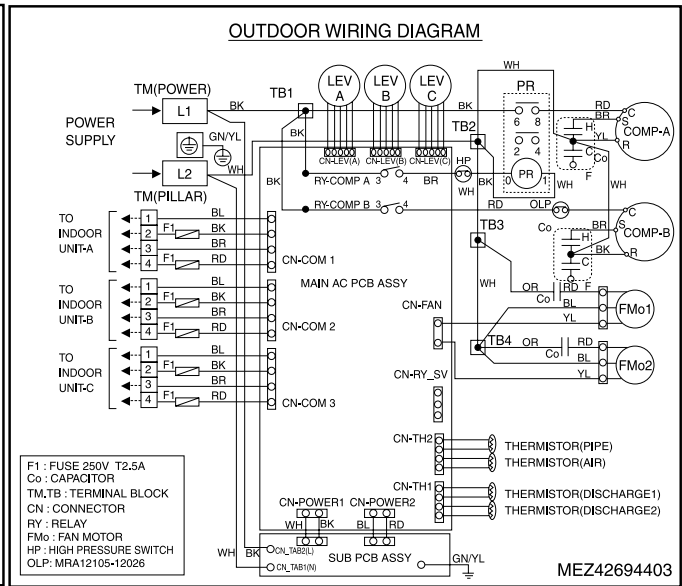

5) A-MMH36FA-1

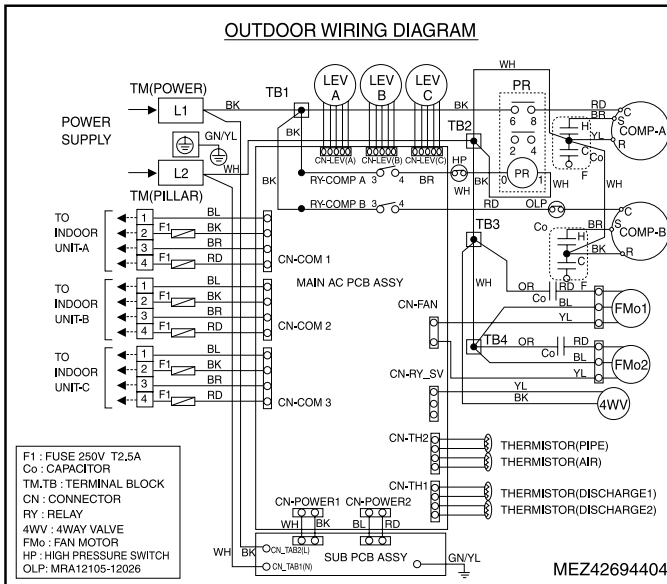

Components Locations

1. Indoor Unit MAIN P.C.B ASM 1) Split Type

• TOP VIEW

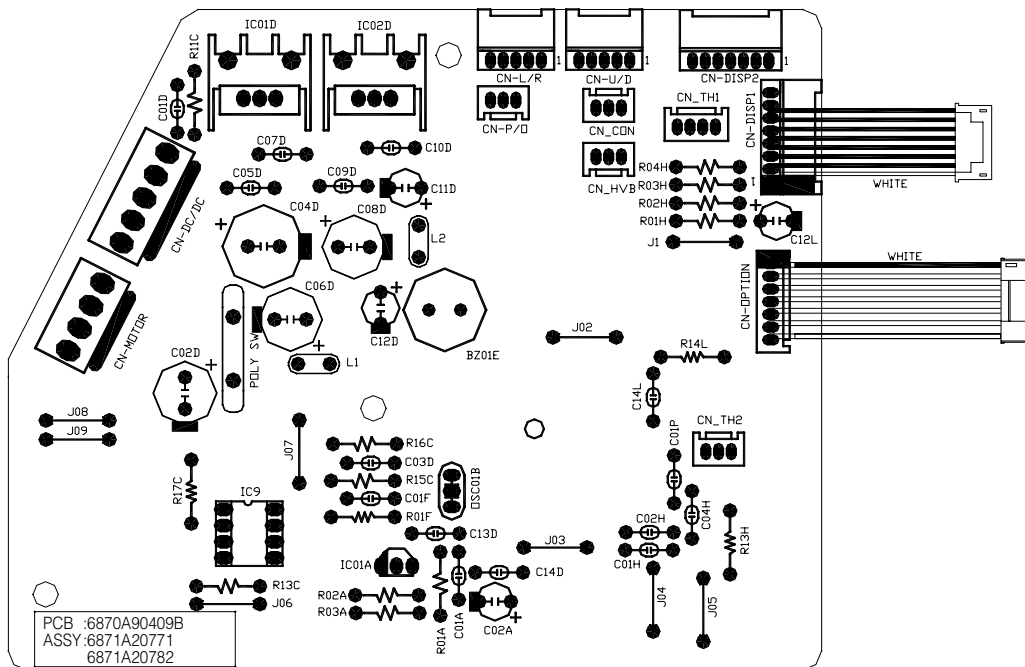

• BOTTOM VIEW

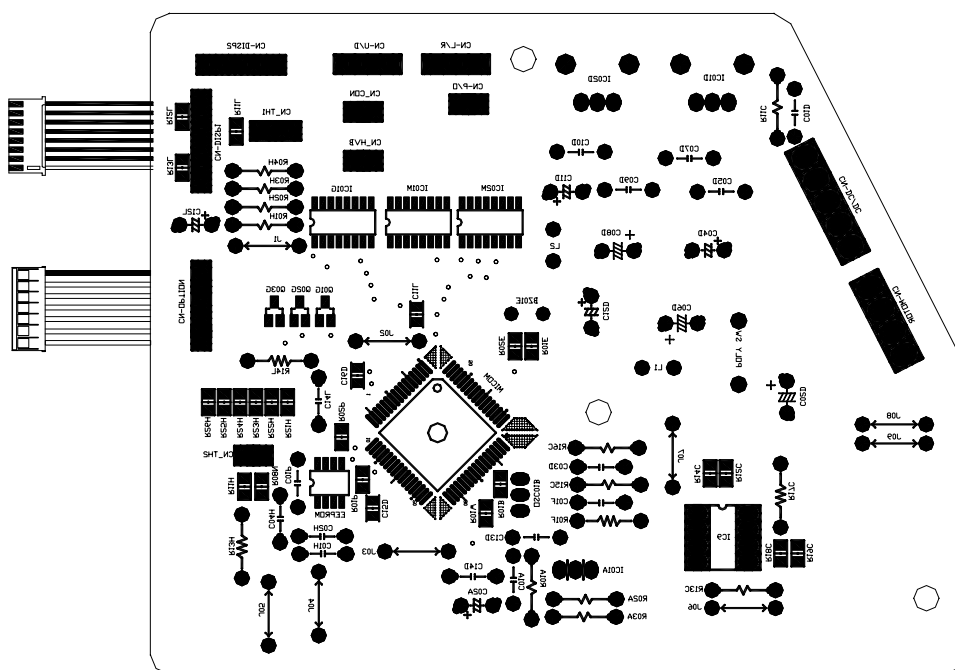

2. Display ASSEMBLY

1) Split Type (6871A20680)

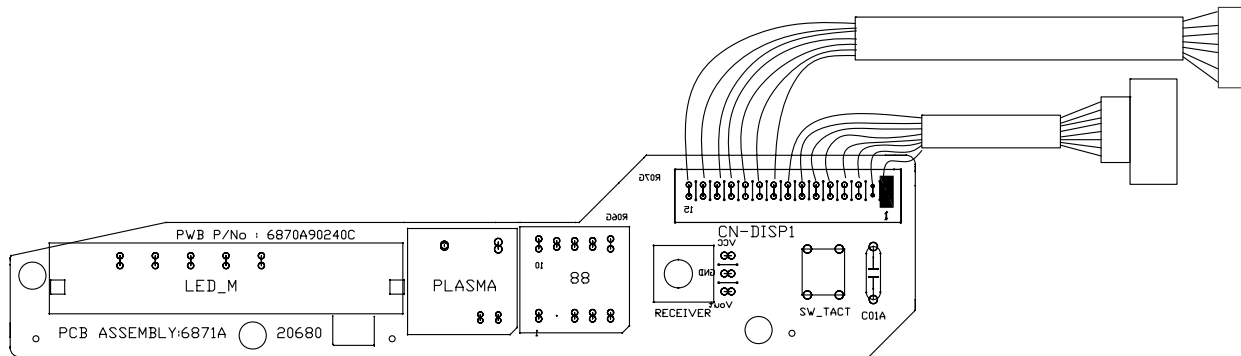

3. Outdoor Unit

1) Component side

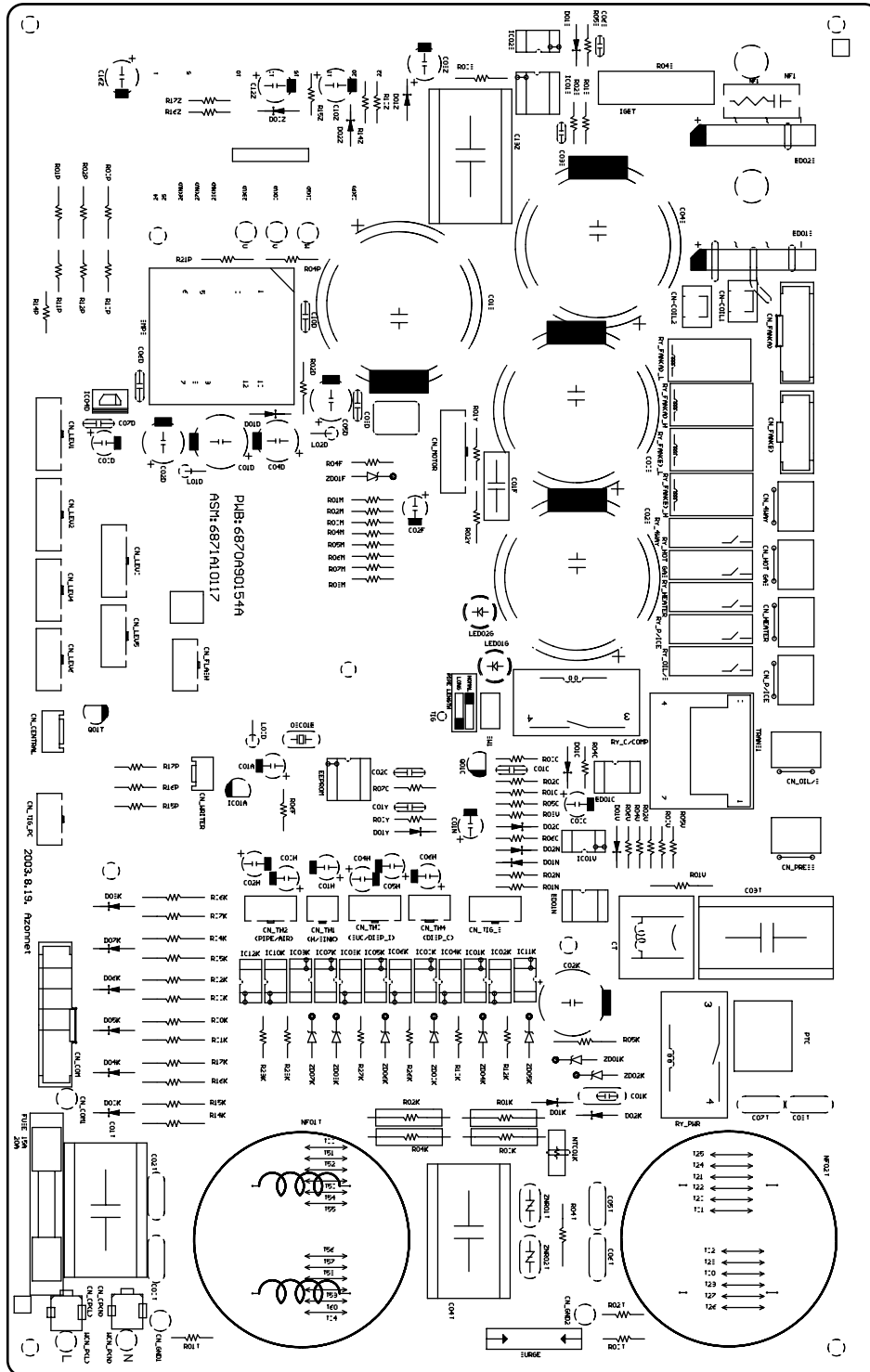

2) Solder side

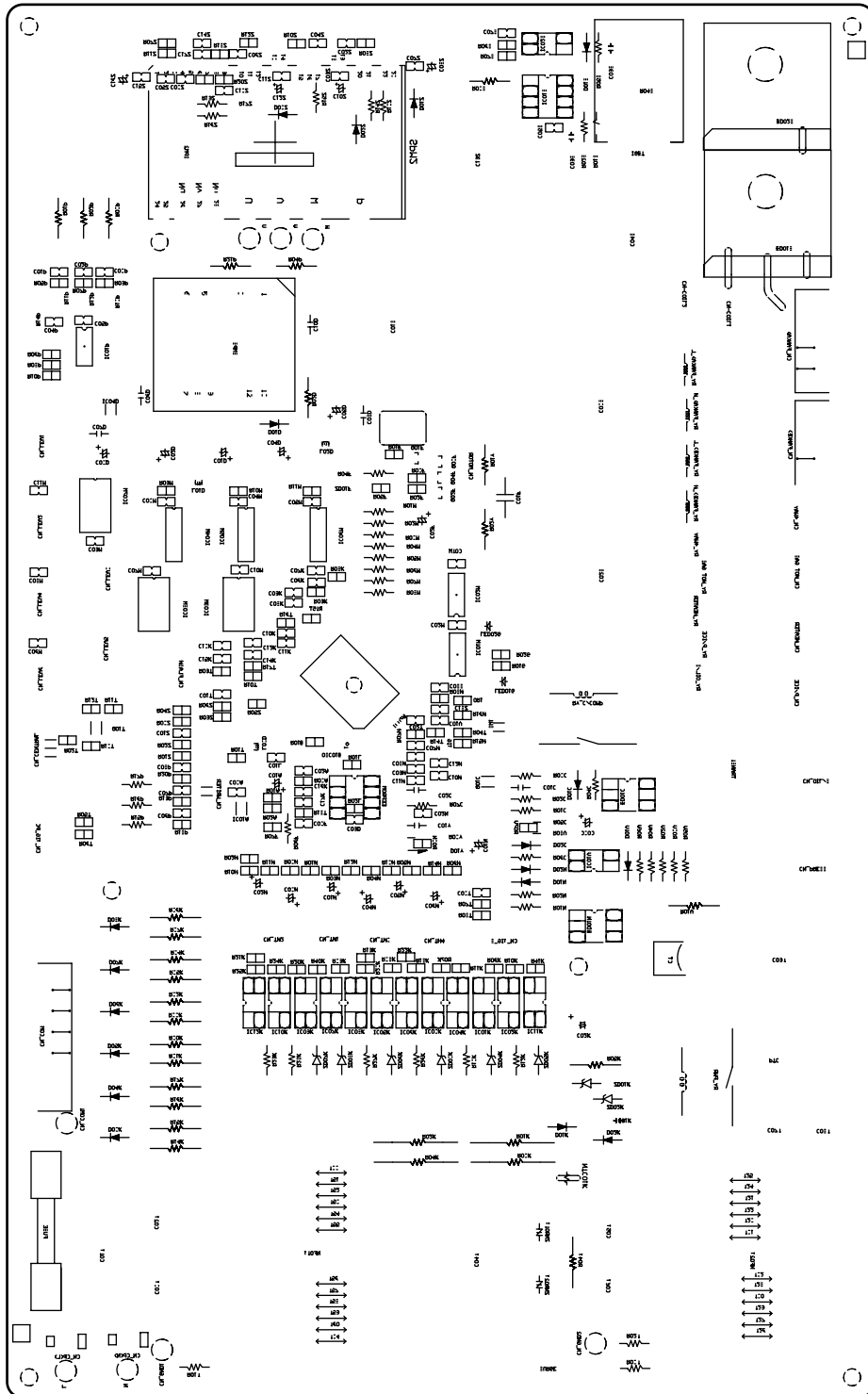

Troubleshooting Guide

Refrigeration Cycle Diagram

1. A-MMH18FA-1

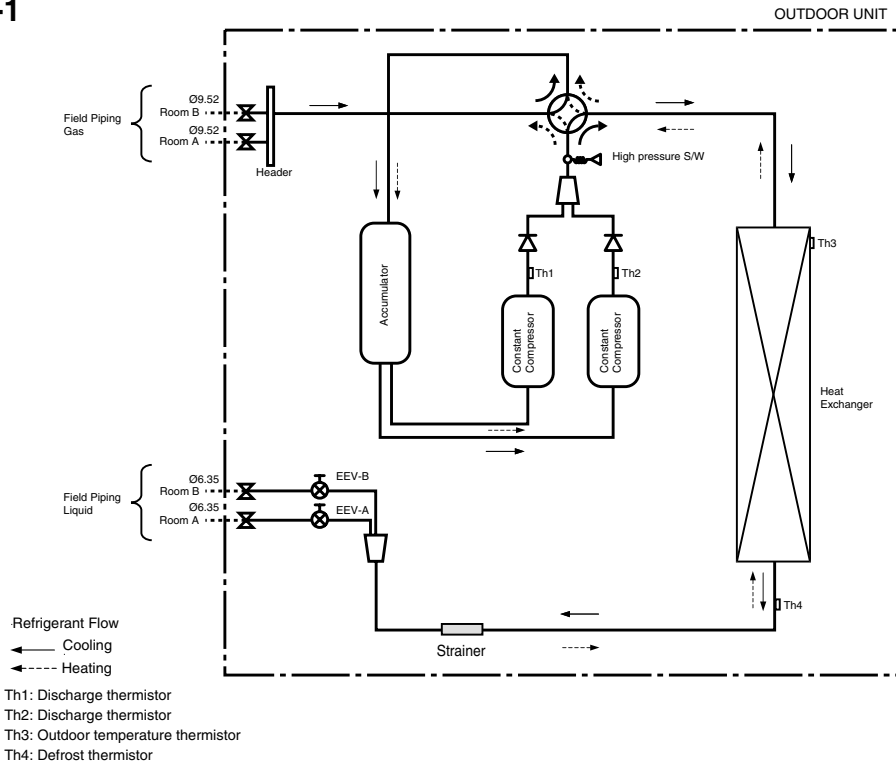

2. A-MMC24FA-1

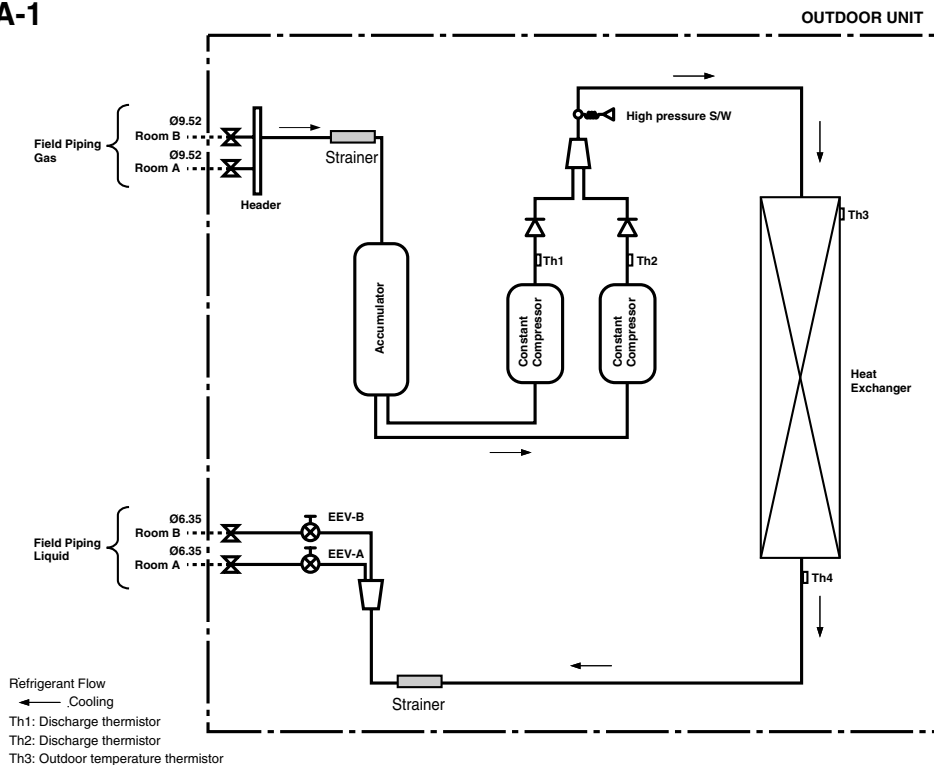

3. A-MMH24FA-1

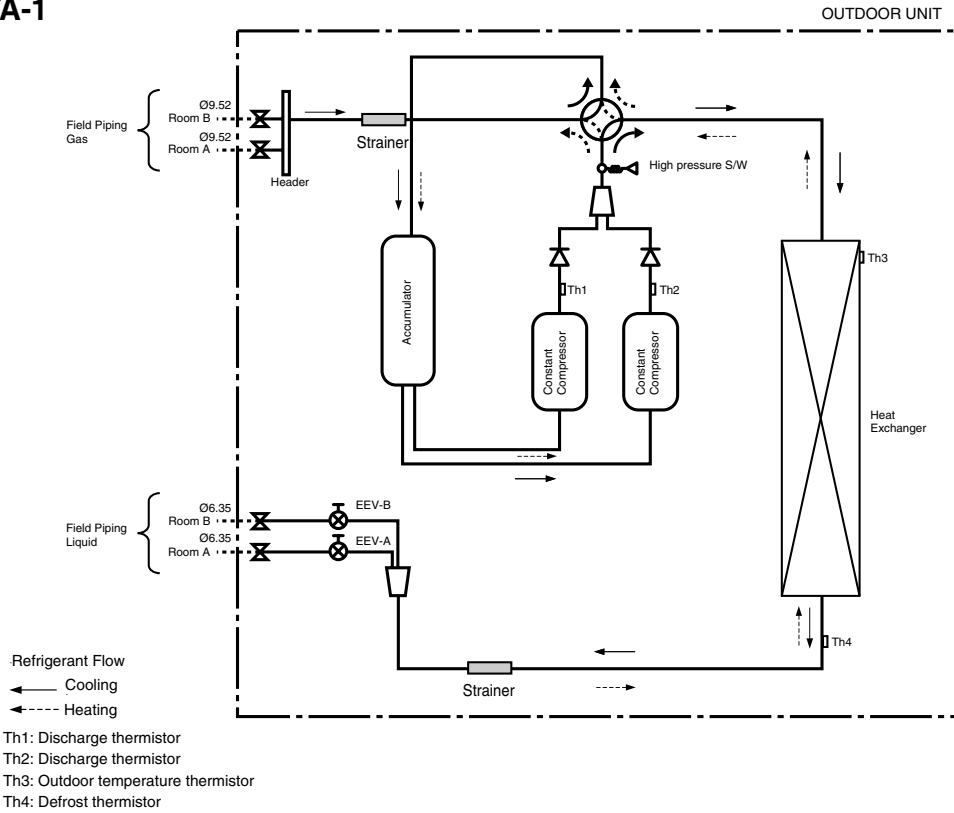

4. A-MMC36FA-1

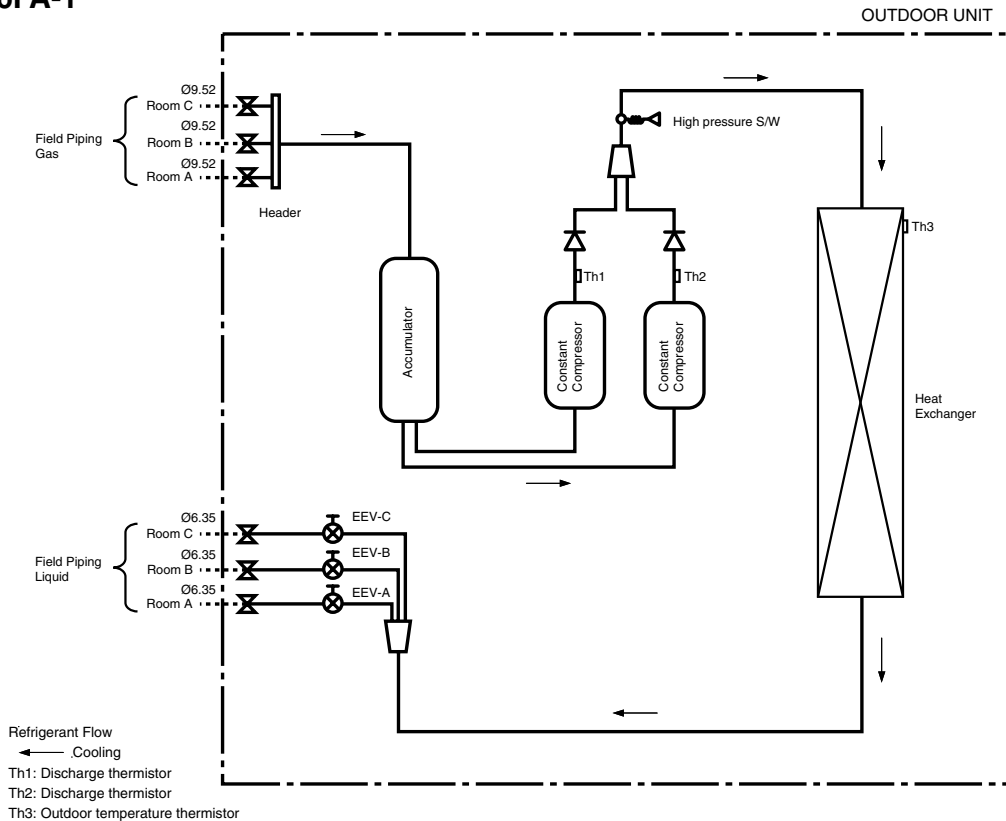

5. A-MMH36FA-1

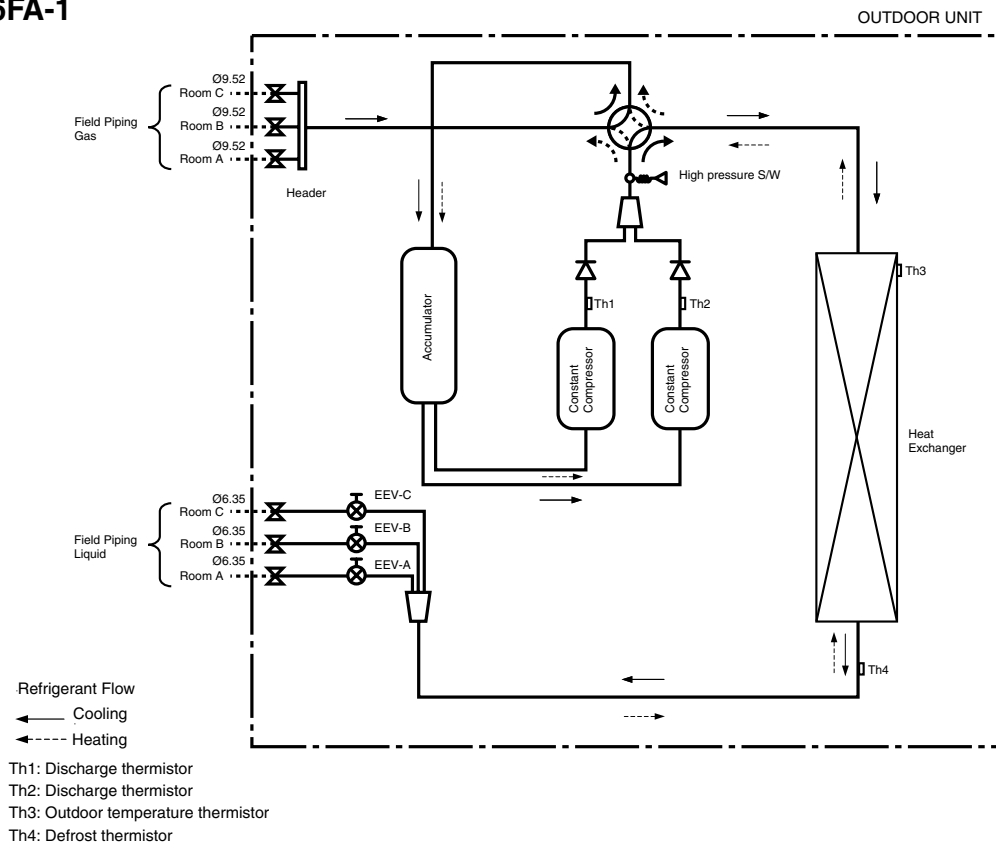

Self-diagnosis Function

■ Error Indicator

- The function is to self-diagnosis airconditioner and express the troubles identifiably if there is any trouble.
- Error mark is ON/OFF for the operation LED of evaporator body in the same manner as the following table.
- If more than two troubles occur simultaneously, primarily the highest trouble fo error code is expressed.
- After error occurrence, if error is released, error LED is also released simultaneously.
- To operate again on the occurrence of error code, be sure to turn off the power and then turn on.
- Having or not of error code is different from Model.

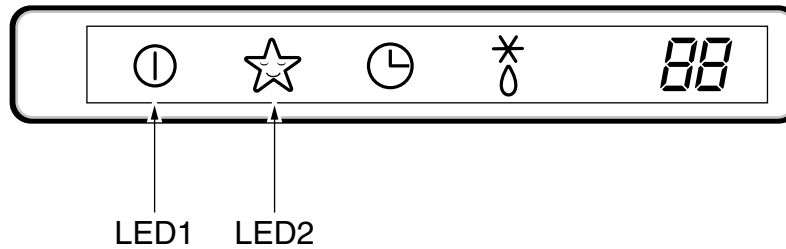

Indoor Error

Error code	Description	MPS Variable	LED1	LED2	Indoor Status
00	No Error	●			ON
01	Indoor Room Thermistor Error	●	1 time ①		OFF
02	Indoor In-Piping Error	●	2 times ①		OFF
05	Communication Error between In and Out	●	5 times ①		OFF
06	Indoor Out-Piping Error	●	6 times ①		OFF
07	Differnt mode operation	●	7 times ①		OFF
10	Indoor fan motor locked error	●		1 times ①	OFF

Outdoor Error

Error code	Description	MPS Variable	LED1(Red)	LED2(Green)	Indoor Status
33	D-Pipe High(Normal)	●	3 times ①	3 times ②	OFF
44	Outdoor Air Thermistor Error(Open/Short)	●	4 times ①	4 times ②	OFF
45	Cond Pipe Thermistor Error(Open/Short)	●	4 times ①	5 times ②	OFF
47	Const. D-Pipe Thermistor Error(Open/Short)	●	4 times ①	7 times ②	OFF
51	Capacity Error(High/Low)	●	5 times ①	1 times ②	OFF

Cycle Troubleshooting Guide

Trouble analysis

1. Check temperature difference between intake and discharge air, and operating current.

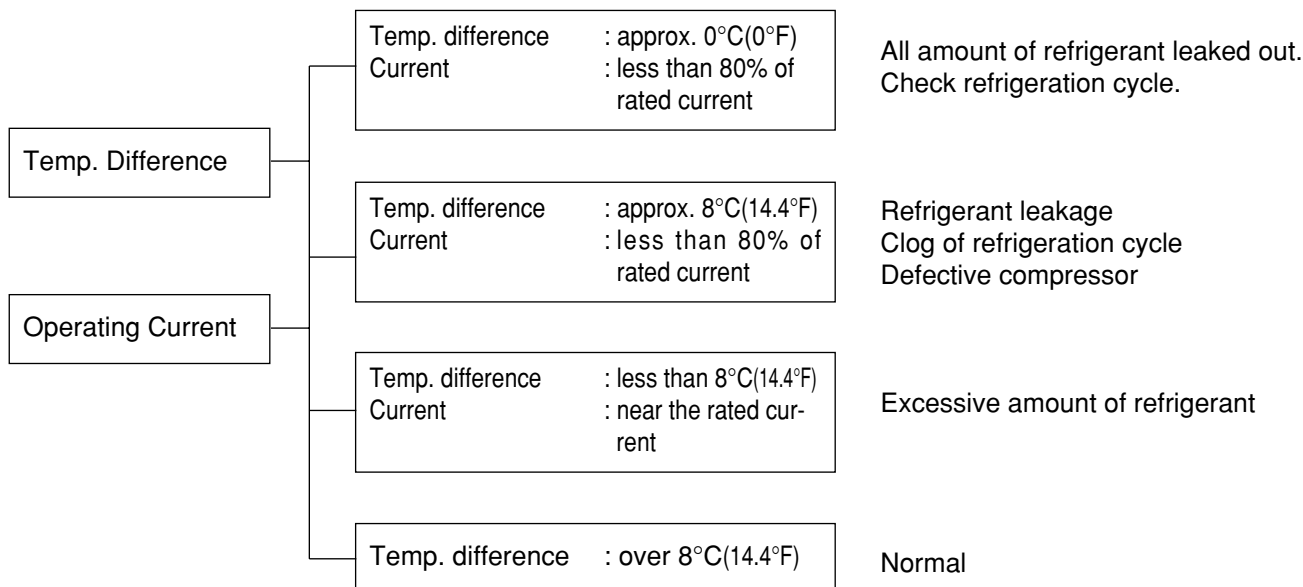

Notice:

Temperature difference between intake and discharge air depends on room air humidity. When the room air humidity is relatively higher, temperature difference is smaller. When the room air humidity is relatively lower temperature difference is larger.

2. Check temperature and pressure of refrigeration cycle.

Suction pressure (Compared with the normal value)	Temperature (Compared with the normal value)	Cause of Trouble	Description
Higher	High	Defective compressor	Current is low.
	Normal	Excessive amount of refrigerant	High pressure does not quickly rise at the beginning of operation.
Lower	Higher	Insufficient amount of refrigerant(Leakage) Clogging	Current is low.

Notice:

1. The suction pressure is usually 4.5~6.0 kg/cm²G at normal condition.
2. The temperature can be measured by attaching the thermometer to the low pressure tubing and wrap it with putty.

Electronic Parts Troubleshooting Guide

* Refer to electronic control device drawing & schematic diagram.

Trouble 1 The Product doesn't operate at all.

Turn off the main power and wait until LED on outdoor PCB is off.



Turn on the main power again.



Does "Beeping" sound is made from the indoor unit?



Check the voltage of power(AC208V/AC230V, 60Hz).

- The voltage of main power.
- The voltage applied to the unit.
- The connecting method of Indoor/Outdoor connecting cable (each color)
- The P.W.B. Ass'y
(Fuse, Noise Filter, Power Transformer, IC01D, IC02D, etc.)



- Primarily, the operating condition of Micom is O.K.



- Check CN-DISP1

The operation check of the P.C.B. Ass'y

Procedure	Specification	Remedy
1) The input voltage of power transformer.	1) AC230V \pm 30V : Check the rated voltage	1) Replace power transformer.
2) The output voltage of power transformer.	2) 15V \pm 1.5V	2) Replace power transformer.
3) IC01D(7812)	3) DC12V	3) Replace IC01D.
4) IC02D(7805)	4) DC5V	4) Replace IC02D.
5) IC01A(KIA7036)	5) The voltage of micom pin 29 : DC4.5V \uparrow	5) Replace IC01A.

Trouble 2 Product doesn't operate with the remote controller.

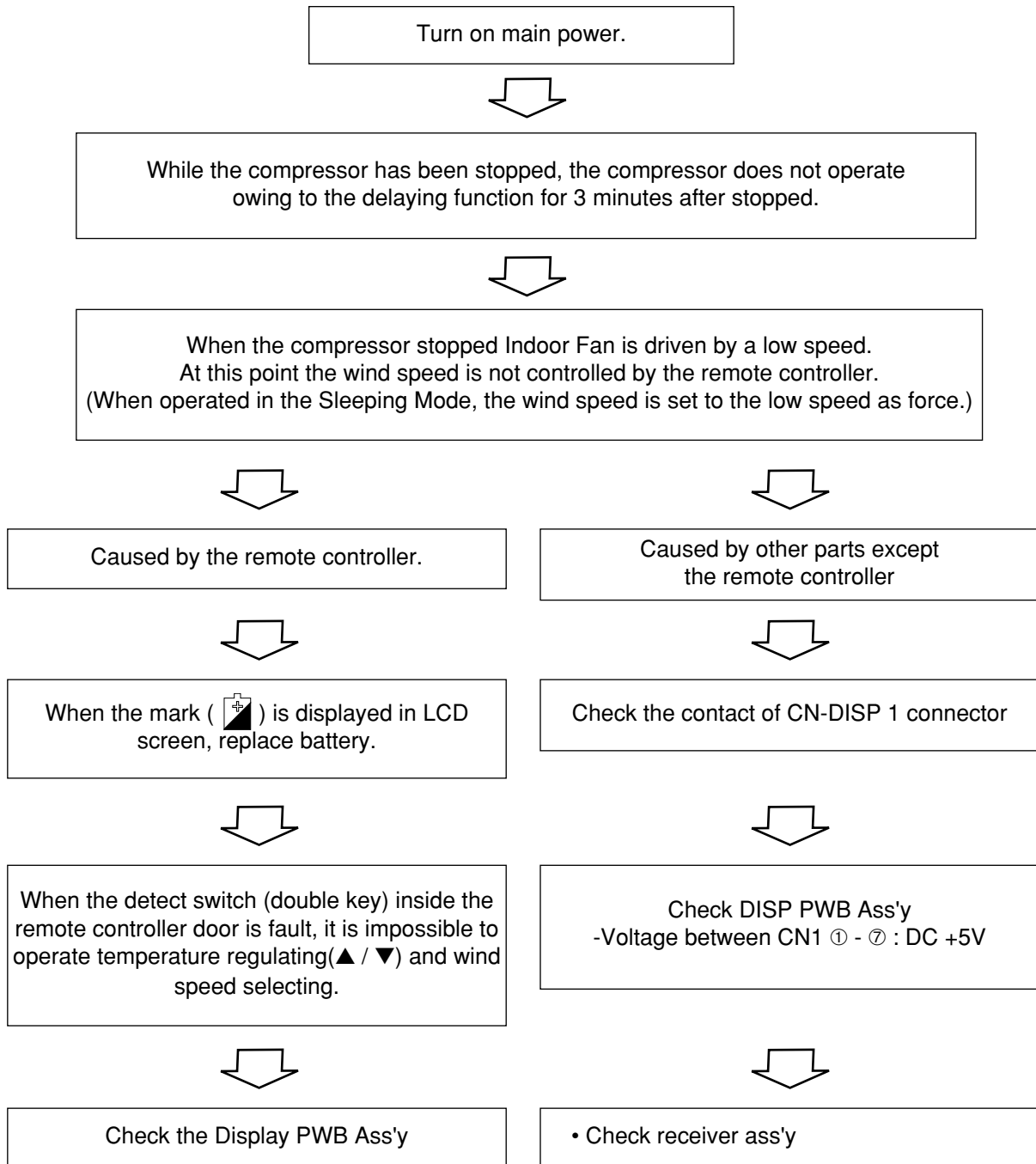

Trouble 3 The Compressor/Outdoor Fan are don't operate

Turn on the main power.



Operate Cooling Mode by setting the disired temperature of the remote controller is less than one of the Indoor temperature by 1°C at least.



When in air circulation mode, compressor/outdoor fan is stopped.



Check the sensor for Indoor temperature is attached as close as to be effected by the temperature of Heat Exchange (EVA.)



When the sensor circuit for Indoor temperature and connector are in bad connection or are not engaged, Compressor/Outdoor fan is stopped.

- Check the related circuit of R01H(1K), R02H(1K), R03H(1K), R04H(1K), Micom(pin No. ⑦④, ⑦⑤, ⑦⑥, ⑦⑦).
- Check the Indoor temperature sensor is disconnected or not (about 10K at 25°C).



Check the Relay(RY-PWR, RY-START) for driving Compressor.

- Check the voltage between brown and blue cable of terminal to connect the Outdoor (About AC208V / 230V).
- Check the related circuit of relay in Outdoor PCB Ass'y.

Check Point	Comp. ON	Comp. OFF
Between Micom(No. 50,51) and GND	DC 5V	DC 0V
Between IC01M(No. 10) and GND	DC 1V↓	DC 12V



Turn off main power.



Check the electrical wiring diagram of Outdoor side.
Check the open or short of connecting wires between Indoor and Outdoor.

Trouble 4 When indoor Fan does not operate.

When indoor Fan does not operate.

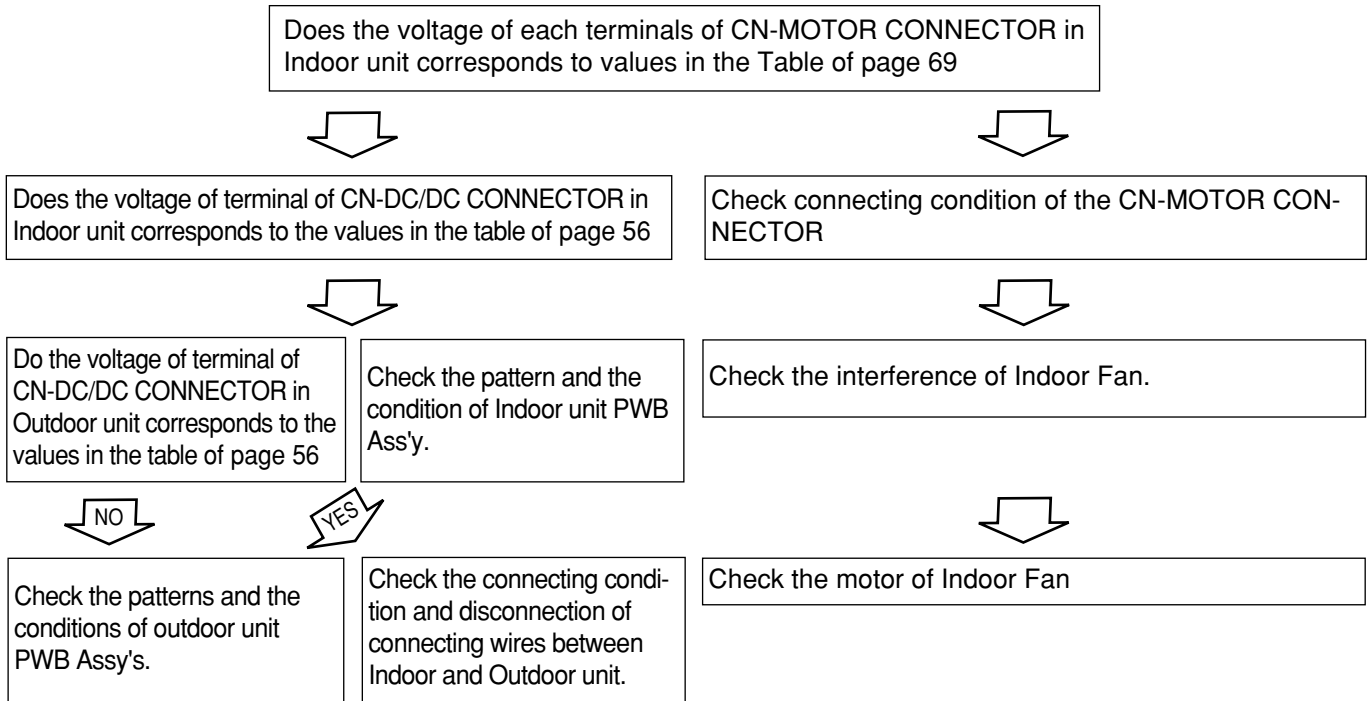

- ※ Indoor Fan may be stopped in the Soft Dry Mode(change to the Cooling Operation Mode).
- ※ Indoor Fan is to be stopped when Indoor pipe(coil) temperature is lower than 79°F.
(At that times, Defrost indicator is turned on)

Trouble 5 When the louver does not operate.

When Vertical Louver does not operate.

- Confirm that the Vertical Louver is normally geared with the shaft of Stepping Motor.
- If the regular torque is detected when rotating the Vertical Louver with hands ⇒ Normal



- Check the connecting condition of CN-UP/DOWN Connector
- Check the soldering condition(on PWB) of CN-UP/DOWN Connector



Check the operating circuit of the Vertical Louver

- Confirm that there is DC +12V between pin②(REDF) of CN-UP/DOWN and GND.
- Confirm that there is a soldering short at following terminals.
 - Between ⑥①, ⑥② and ⑥③ of MICOM
 - Between ②, ③, ④ and ⑤ of IC01M
 - Between ⑫, ⑬, ⑭, ⑮ of IC01M
 - Between ①, ②, ③, ④ and ⑤ of CN-UP/DOWN



If there are no problems after above checks

- Confirm the assembly conditions that are catching and interfering parts in the rotation radial of the Vertical Louver

Error Code

■ Trouble Shooting

Error code	Title	Cause of error	Check point & Normal condition
01	Indoor air sensor	<ul style="list-style-type: none"> • Open / Short • Soldered poorly • Internal circuit error 	Normal resistor : 10K Ω / at 25°C(77°F) (Unplugged) Normal voltage : 2.5Vdc / at 25°C(77°F) (plugged)
02	Indoor inlet pipe sensor	<ul style="list-style-type: none"> • Open / Short • Soldered poorly • Internal circuit error 	Normal resistor : 5K Ω / at 25°C(77°F) (Unplugged) Normal voltage : 2.5Vdc / at 25°C(77°F) (plugged)
06	Indoor outlet pipe sensor	<ul style="list-style-type: none"> • Open / Short • Soldered poorly • Internal circuit error 	Normal resistor : 5K Ω / at 25°C(77°F) (Unplugged) Normal voltage : 2.5Vdc / at 25°C(77°F) (plugged)

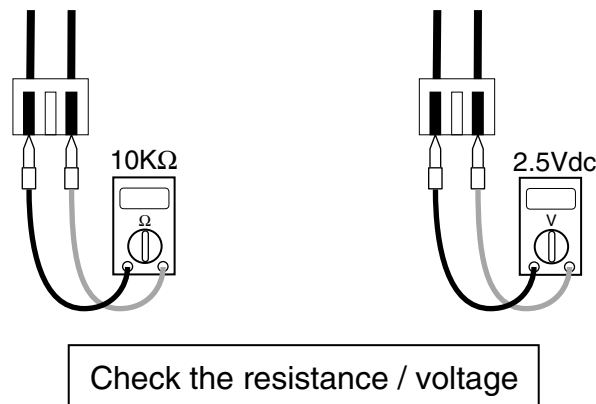

□ Check Point

1. Unplug the sensor on Indoor unit PCB.
2. Estimate the resistance of each sensor
3. If the resistance of the sensor is 10K Ω /5K Ω at 25°C(77°F), then sensor is normal
4. If the resistance of the sensor is 0 K Ω or ∞ , then sensor is abnormal. → Change the sensor.
5. Plug the sensor on Indoor unit PCB and Power ON.
6. Estimate the voltage of each sensor.
7. If the voltage of the sensor is 2.5Vdc / at 25°C(77°F), then sensor is normal.
8. If the resistance of the sensor is 0 or 5Vdc, then sensor is abnormal. → Repair or Change the PCB

Error code	Title	Cause of error	Check point & Normal condition
05 / 53	Communication (Indoor → Outdoor)	<ul style="list-style-type: none"> • Communication poorly 	<ul style="list-style-type: none"> • Power input AC 230V.(Outdoor, Indoor) • The connector for transmission is disconnected. • The connecting wires are misconnected. • The GND 1,2 is not connected at main GND. • The communication line is shorted at GND. • Transmission circuit of outdoor PCB is abnormal. • Transmission circuit of indoor PCB is abnormal.

□ Check Point

1. Check the input power AC 230V.(Outdoor, Indoor)
2. Check the communication wires are correctly connected.
 - Adjust the connection of wire
 - Confirm the wire of "Live", "Neutral".
3. Check the resistance between communication line and GND.(Normal : Over 2MΩ)
4. Check the connector for communication is correctly connected.
5. Check the connection of GND1, GND2, and main GND.
6. If one indoor unit is operated normally, outdoor PCB is no problem.
 - Check the another indoor unit.

* CH05 is displayed at indoor unit, CH53 is displayed at outdoor unit.

Error code	Title	Cause of error	Check point & Normal condition
33	D-Pipe Temp. High	<ul style="list-style-type: none"> Discharge sensor temp. high 	<ul style="list-style-type: none"> Check the discharge pipe sensor. Check the install condition for over load. Check the leakage of refrigerent. Check the SVC V/V open.

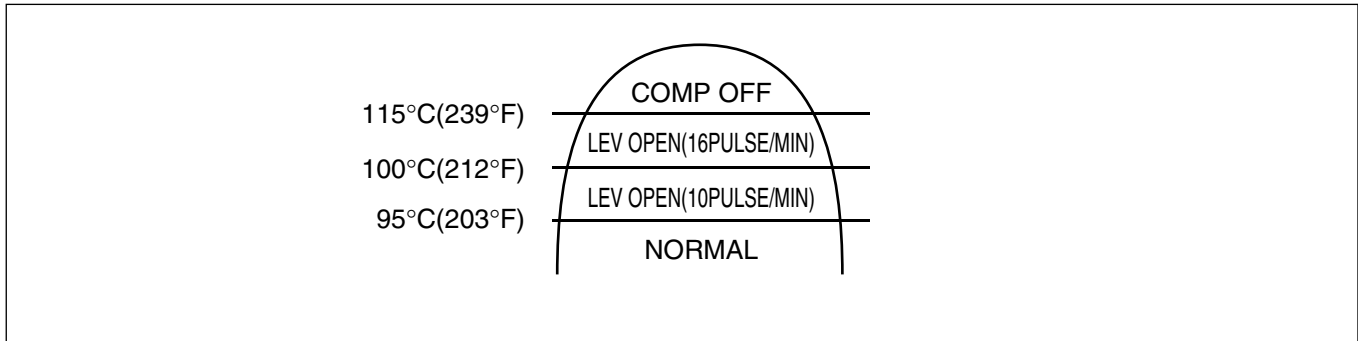

□ Check Point

1. Check the install condition for over load.
2. Check the SVC V/V open.
3. Check the leakage of refrigerent.
4. Check the constant compressor.

Error code	Title	Cause of error	Check point & Normal condition
51	Capacitor error	<ul style="list-style-type: none"> Over Capacitor combination 	<ul style="list-style-type: none"> Check the indoor unit capacity. Check the combination table

□ Check Point

1. Check the indoor unit capacity.
 2. Check the combination table.
- ★ In the tropical model case
 → single cycle has no error for over capacity.

Error code	Title	Cause of error	Check point & Normal condition
44	Outdoor air sensor	<ul style="list-style-type: none"> • Open / Short • Soldered poorly • Internal circuit error 	Normal resistor : 10KΩ / at 25°C(77°F) (Unplugged) Normal voltage : 2.5Vdc / at 25°C(77°F) (plugged)
45	Condensor pipe sensor	<ul style="list-style-type: none"> • Open / Short • Soldered poorly • Internal circuit error 	Normal resistor : 5KΩ / at 25°C(77°F) (Unplugged) Normal voltage : 2.5Vdc / at 25°C(77°F) (plugged)
47	D-Pipe sensor	<ul style="list-style-type: none"> • Open / Short • Soldered poorly • Internal circuit error 	Normal resistor : 200KΩ / at 25°C(77°F) (Unplugged) Normal voltage : 4.5Vdc / at 25°C(77°F) (plugged)

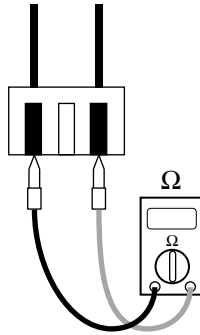

Check the resistance

□ Check Point

1. Estimate the resistance of each sensor.(Unplugged)
2. Estimate the voltage of each sensor.(Plugged)
3. If the resistance is 0V or 5Vdc, then sensor is abnormal

2-way, 3-way Valve

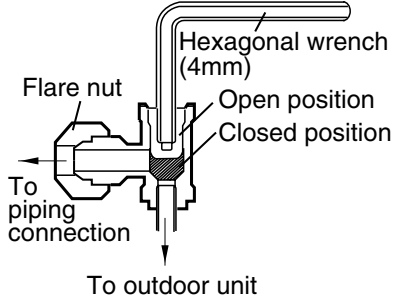
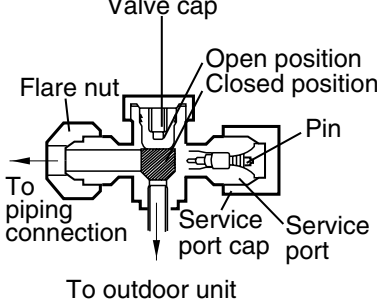
		2-way Valve (Liquid Side)	3-way Valve (Gas Side)	
				
Works		Shaft position	Shaft position	Service port
Shipping		Closed (with valve cap)	Closed (with valve cap)	Closed (with cap)
1.	Air purging (Installation)	Open (counter-clockwise)	Closed (clockwise)	Open (push-pin or with vacuum pump)
Operation		Open (with valve cap)	Open (with valve cap)	Closed (with cap)
2.	Pumping down (Transferring)	Closed (clockwise)	Open (counter-clockwise)	Open (connected manifold gauge)
3.	Evacuation (Servicing)	Open	Open	Open (with charging cylinder)
4.	Gas charging (Servicing)	Open	Open	Open (with charging cylinder)
5.	Pressure check (Servicing)	Open	Open	Open (with charging cylinder)
6.	Gas releasing (Servicing)	Open	Open	Open (with charging cylinder)

(1) Pumping down

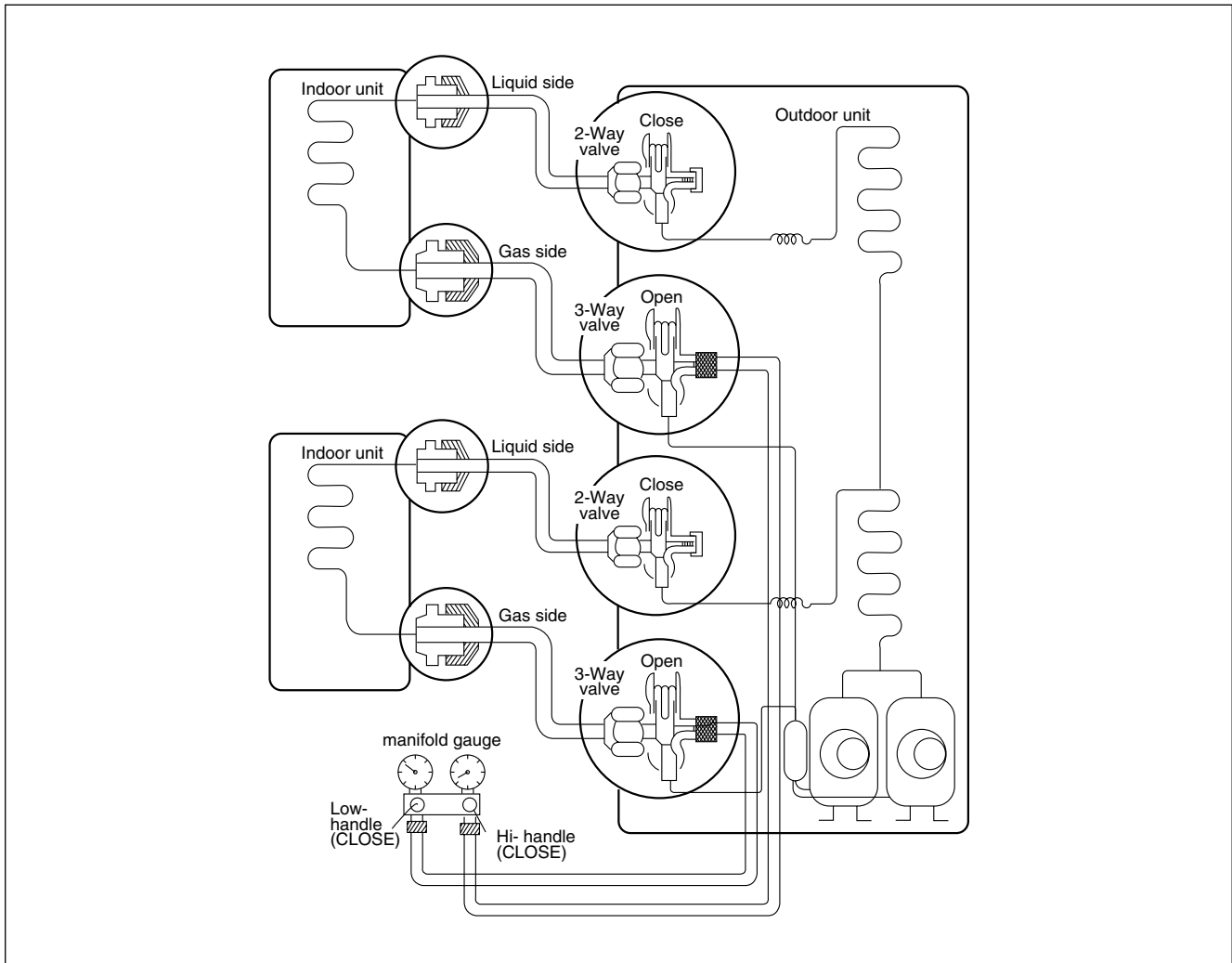

• Procedure

1. **Confirm that both the gas side and liquid side valves are set to the open position.**
 - Remove the valve stem caps and confirm that the valve stems are in the raised position.
 - Be sure to use a hexagonal wrench to operate the valve stems.
 2. **Operate the unit for 10 to 15 minutes.**
 3. **Stop operation and wait for 3 minutes, then connect the manifold gauge to the service port of the gas side valve.**
 - Connect the hose of the gauge with the push pin to the service port.
 4. **Air purging of the charge hose.**
 - Open the Low-handle valve on the gauge slightly to air purge from the hose.
 5. **Set the liquid side valve to the closed position.**
 6. **Operate the air conditioner at the cooling cycle and stop it when the gauge indicates 1kg/cm²g.**
 7. **Immediately set the gas side valve to the closed position.**
 - Do this quickly so that the gauge ends up indicating 1kg/cm²g.
 8. **Disconnect the charge set, and mount the liquid side and gas side valve caps and the service port nut.**
 - Use torque wrench to tighten the service port nut to a torque of 1.8kg.m.(156.2 lbf-in) [4.2kg.m (364.5 lbf-in)/5.5kg.m (477.4 lbf-in)]
 - Be sure to check for gas leakage.
- Be sure to short pressure S/W. otherwise Low pressure S/W detect low pressure skete and stops the compressor.

(2) Evacuation

(All amount of refrigerant leaked)

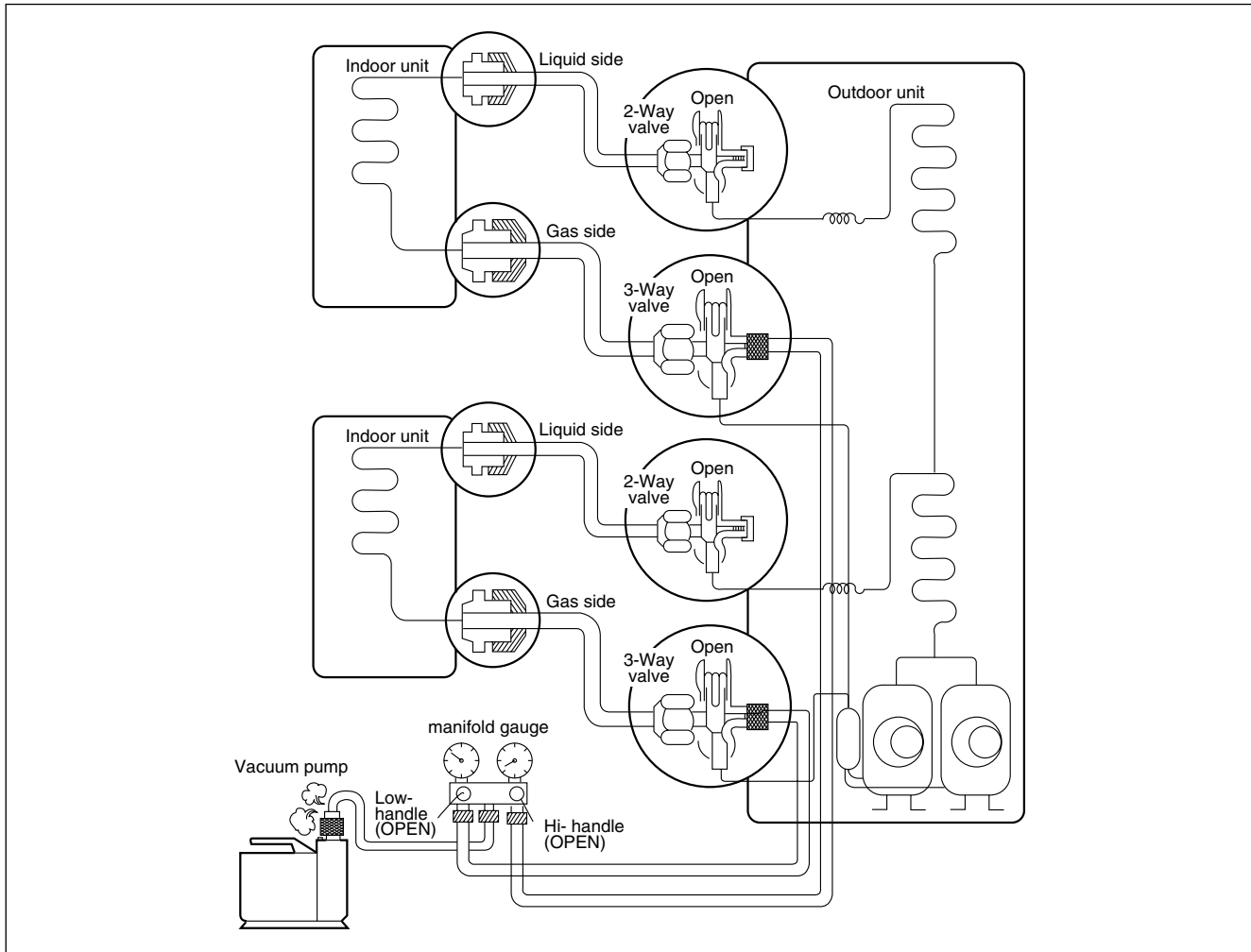

• Procedure

1. Confirm that both the liquid side valve and gas side valve are set to the opened position.
2. Connect the vacuum pump to the center hose of the manifold gauge.
3. Connect the service port of the gas side valve to the low side of the gauge.
4. Evacuation for approximately one hour.
 - Confirm that the gauge needle has moved toward -76 cmHg (vacuum of 4 mmHg or less).
5. Close the Low handle of the gauge turn off the vacuum pump, and confirm that the gauge needle does not move (approximately 5 minutes after turning off the vacuum pump).
6. Disconnect the charge hose from the vacuum pump.
 - Vacuum pump oil.
 - If the vacuum pump oil becomes dirty or depleted, replenish as needed.
7. Mount the valve caps and the service port caps.

(3) Gas Charging

(After Evacuation)

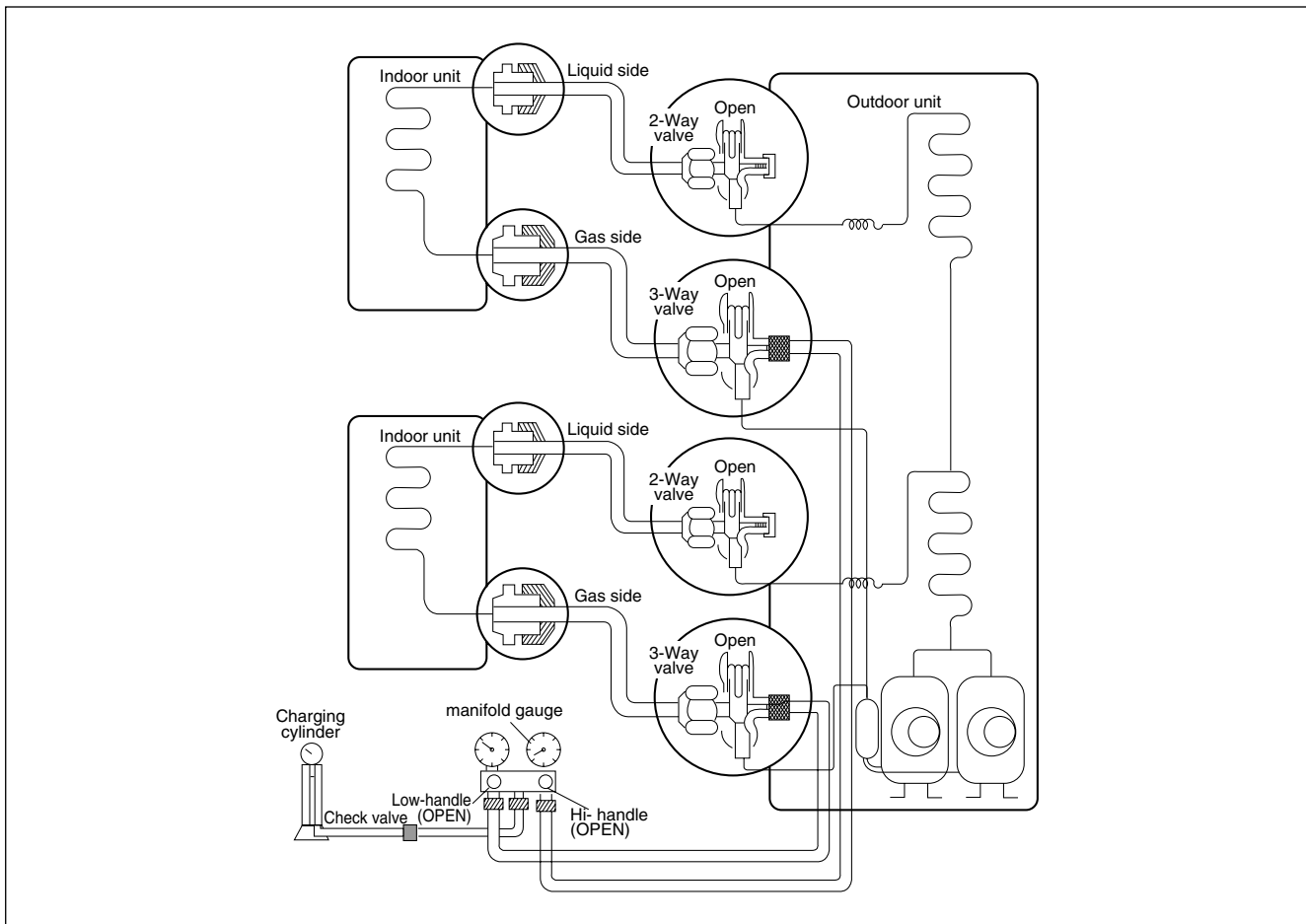

• Procedure

1. Connect the gauge to the charging cylinder.

- Connect the charge hose which you disconnected from the vacuum pump to the valve at the bottom of the cylinder.
- If you are using a gas cylinder, also use a scale and reverse the cylinder so that the system can be charged with liquid.

2. Purge the air from the charge hose.

- Open the valve at the bottom of the cylinder and press the check valve on the charge set to purge the air. (Be careful of the liquid refrigerant). The procedure is the same if using a gas cylinder.

3. Open the low handle on the gauge and charge the system with liquid refrigerant.

- If the system can not be charged with the specified amount of refrigerant, it can be charged with a little at a time (approximately 150g each time) while operating the air conditioner in the cooling cycle; however, one time is not sufficient, wait approximately 1 minute and then repeat the procedure(pumping down-pin).

4. Immediately disconnect the charge hose from the gas side valve's service port.

This is different from previous procedures. Because you are charging with liquid refrigerant from the gas side, absolutely do not attempt to charge with larger amounts of liquid refrigerant while operating the air conditioner.

- Stopping partway will allow the gas to be discharged.
- If the system has been charged with liquid refrigerant while operating the air conditioner turn off the air conditioner before disconnecting the hose.

5. Mount the valve stem nuts and the service port nut.

- Use torque wrench to tighten the service port nut to a torque of 1.8 kg.m.(4.2kg.m/5.5kg.m.)
- Be sure to check for gas leakage.

Exploded View

Indoor Unit

Model : B-MMC09FA-1, B-MMH09FA-1, B-MMC12FA-1, B-MMH12FA-1

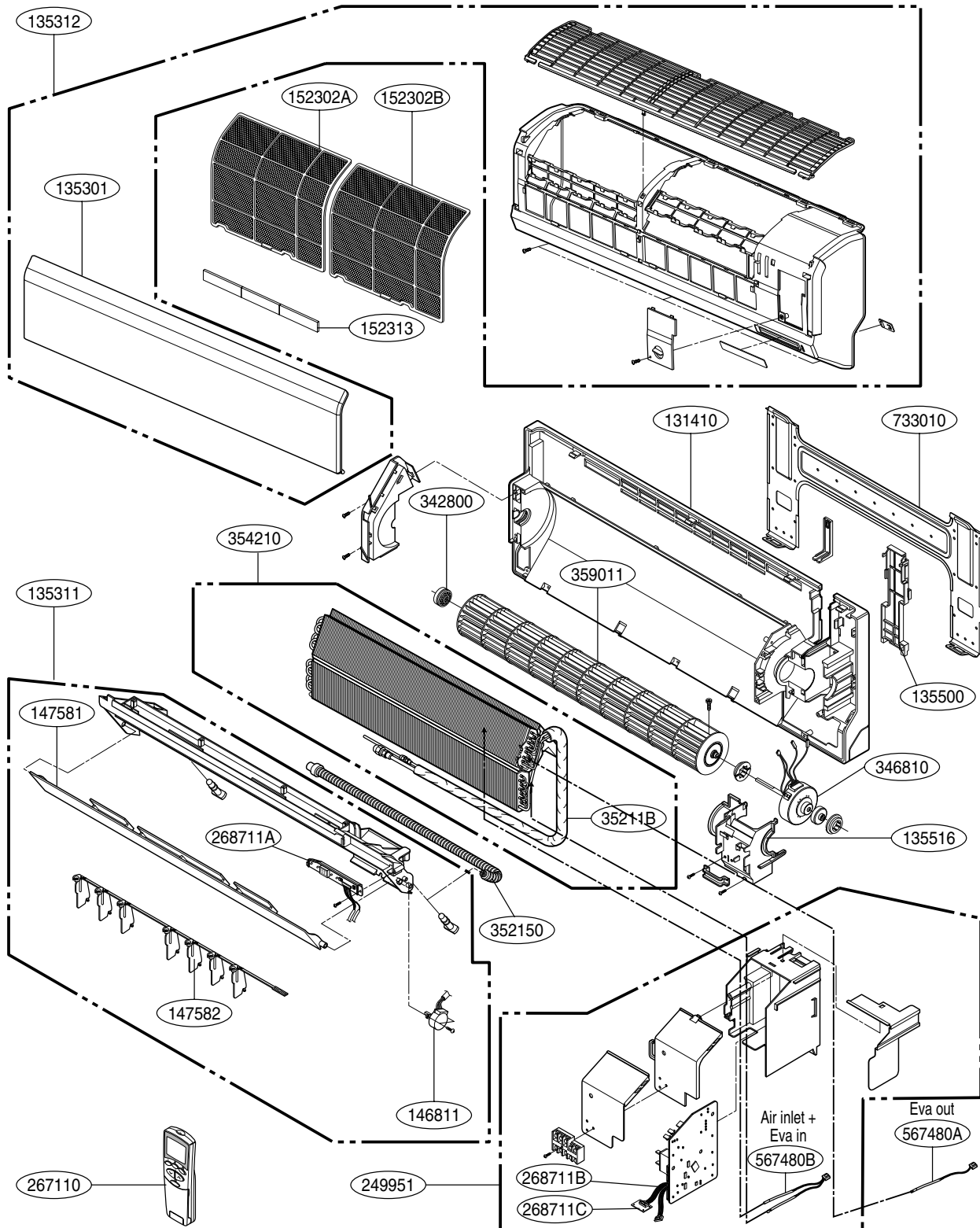

Outdoor Unit

Model : A-MMH18FA-1

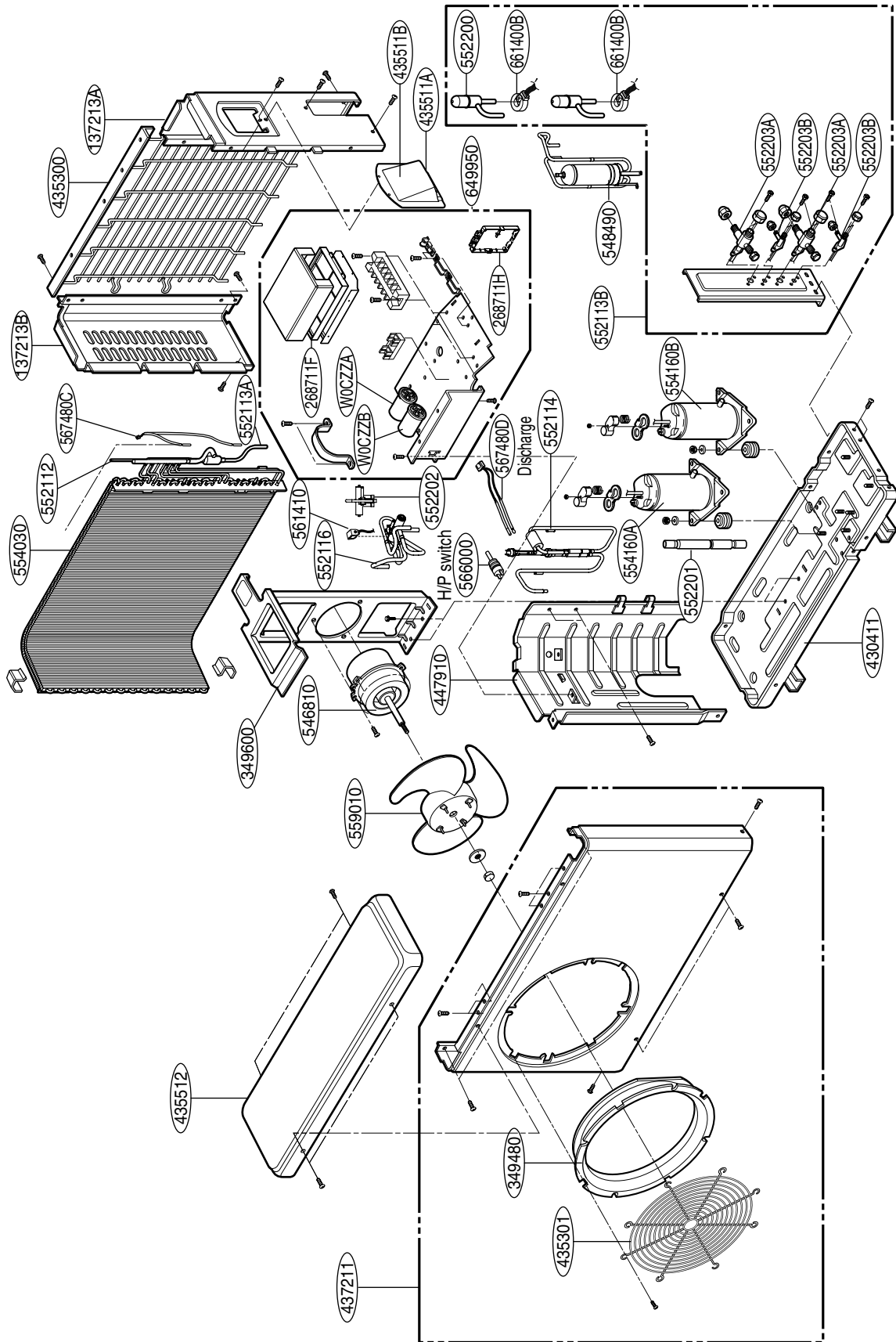

Model : A-MMC24FA-1, A-MMH24FA-1

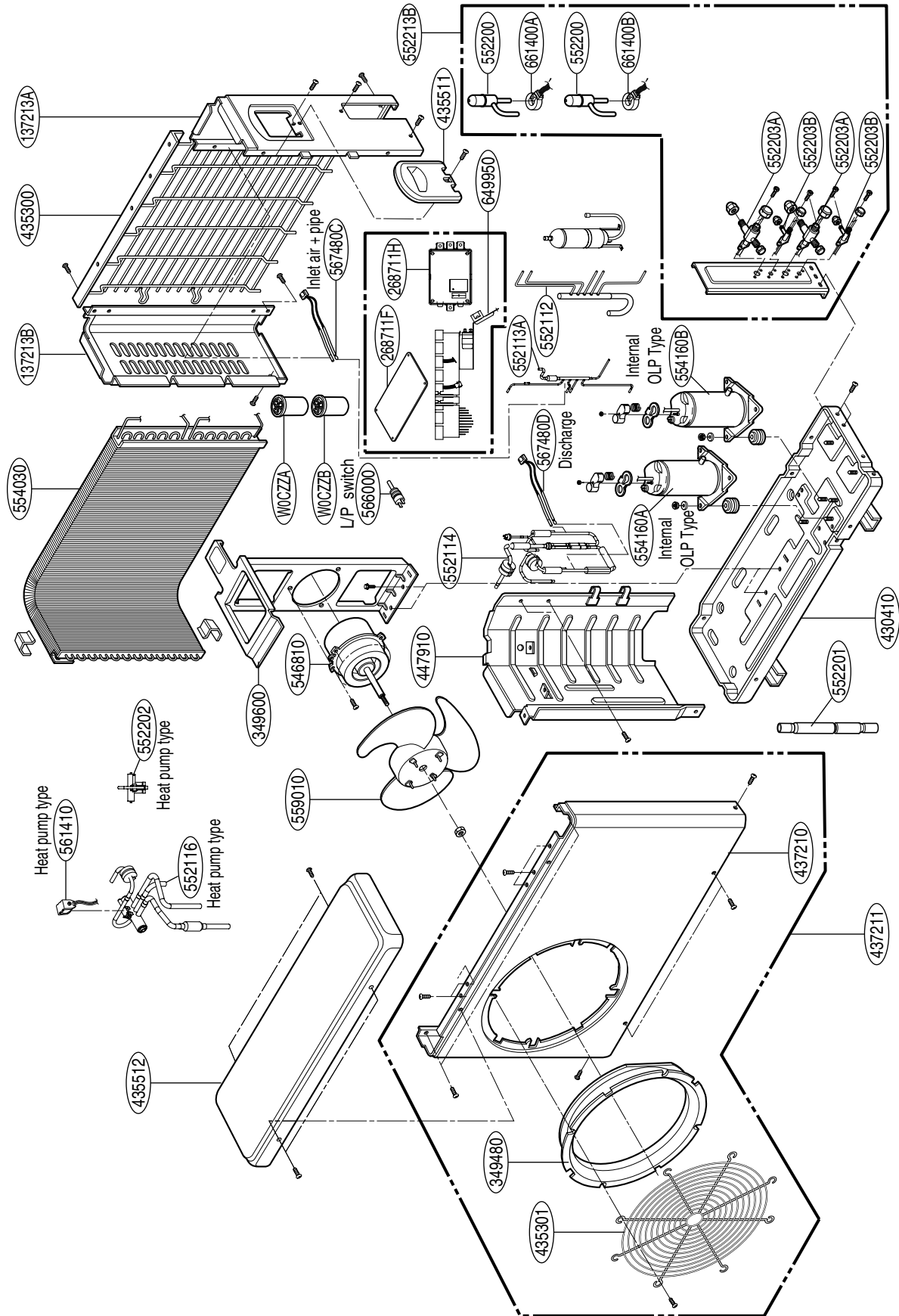

Model : A-MMC36FA-1, A-MMH36FA-1

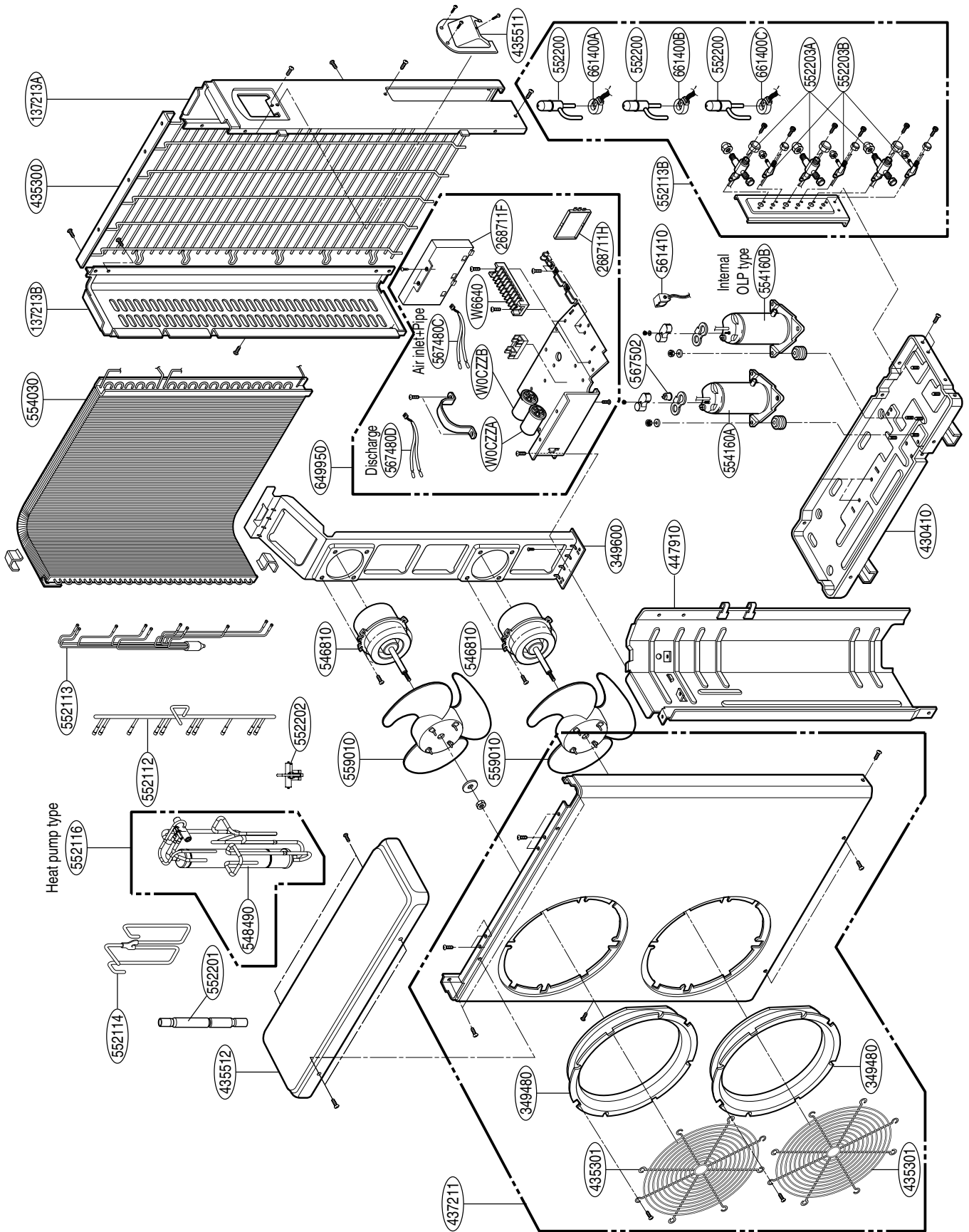

Specifications and performance data subject to change without notice.

HEAT CONTROLLER, INC.

1900 WELLWORTH AVENUE • JACKSON, MICHIGAN 49203

THE QUALITY LEADER IN CONDITIONING AIR

P/No.:3828A20390X