

This Owner's Manual is provided and hosted by [Appliance Factory Parts](#).



LG AG1AC17BKM01 Owner's Manual

[Shop genuine replacement parts for LG
AG1AC17BKM01](#)



[Find Your LG Air Conditioner Parts - Select From 2328 Models](#)

----- Manual continues below -----

Disassembly of the parts (Indoor unit)

Warning:

Disconnect the unit from power supply before making any checks.

Be sure the power switch is set to "OFF".

1. To remove the Grille from the Chassis.

- Set the up-and-down air discharge louver to open position (horizontally) by finger pressure.
- Remove the securing screws at the bottom of grille.
- To remove the Grille, pull the lower left and right side of the grille toward you (Slightly titled) and lift it straight upward.

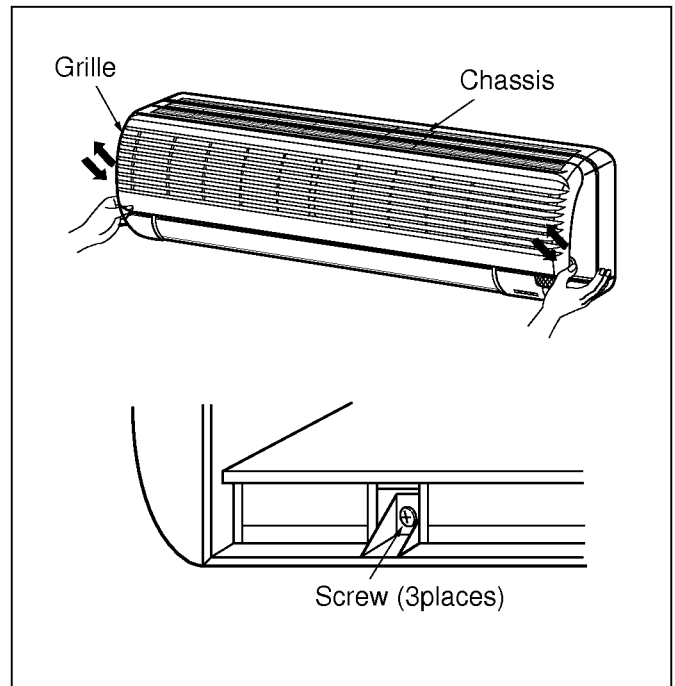

2. To remove the Control Box.

- Remove the thermistors. One from thermister holder on evaporator, the other from pipe holder.
- Remove three step motor connectors, motor connector, Negative-Ion connector from main P. C. B.
- If necessary, disconnect DC power supply cord from pillar terminal, and remove the cord clamp screw. (Be careful not to lose the cord clamp when reassembling)

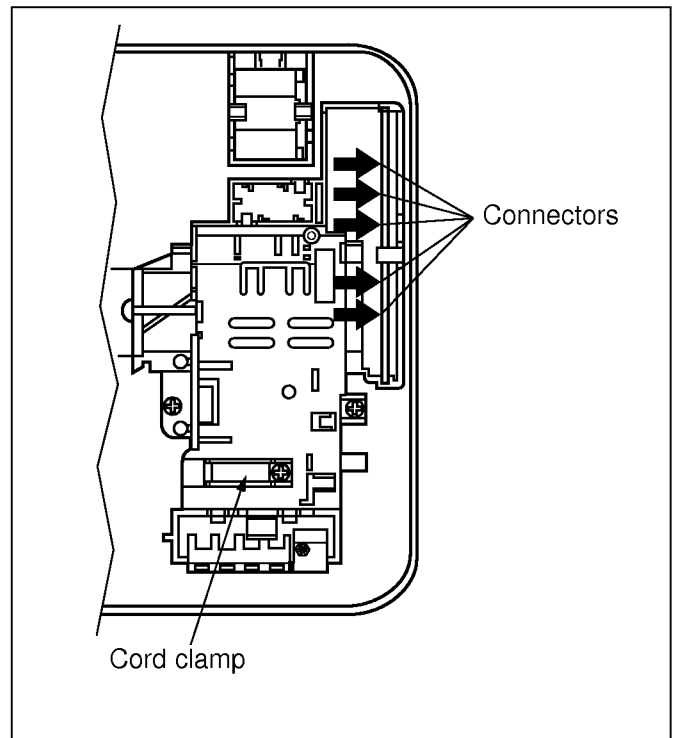
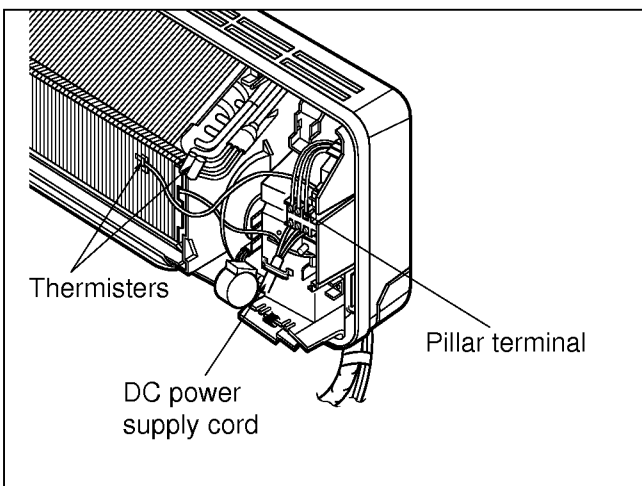

- Remove three screws fixing control box and motor.
- Remove control box assembly holding two hooks fixing upper sides of motor.

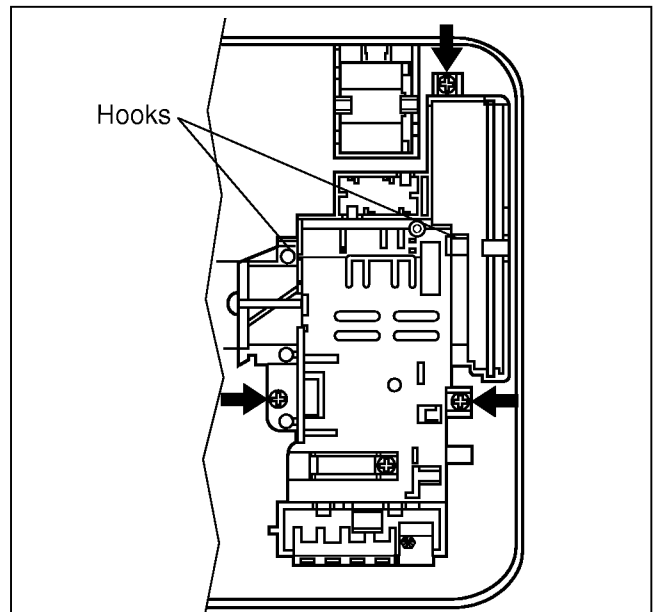

3. To remove the Discharge Grille.

- Remove a screw on the left side of chassis.
- Pull the right side of the discharge grille out from the chassis first and left side carefully.

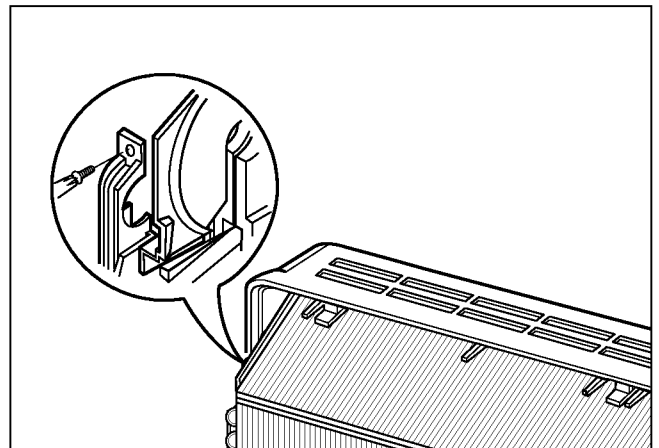

4. To remove the Evaporator.

- Unhook the tab on the left inside edge of the chassis by pressing it outwards.

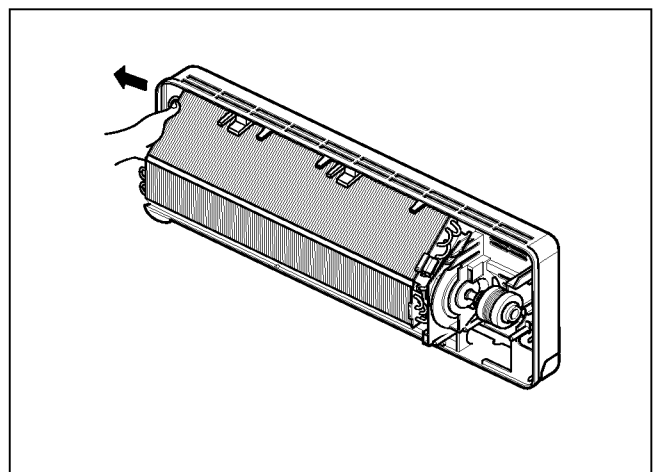

- Slightly pull the evaporator until left tab on end-plate is clear of the chassis.
- Lift the left side of evaporator slightly from the chassis carefully.

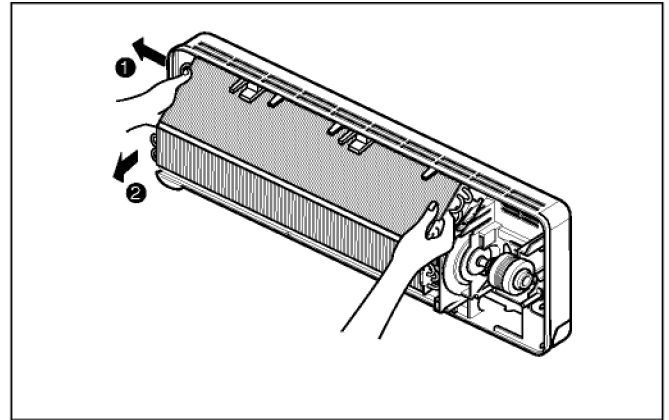

- Push right carefully in order to unhook the tabs on the right inside of the chassis and pull the evaporator toward you.

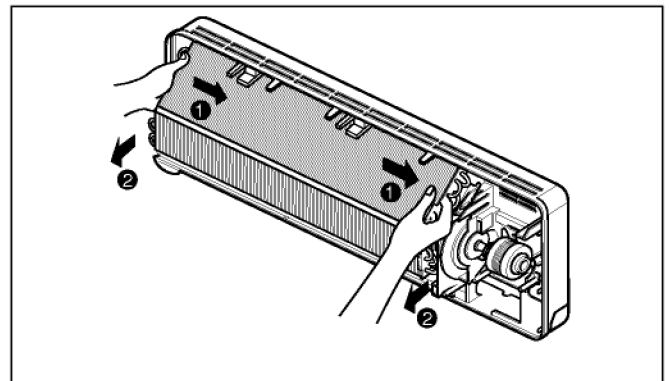

5. To remove the Cross-Flow Fan.

- Loosen the screw securing the cross-flow fan to the fan motor shaft(do not remove).

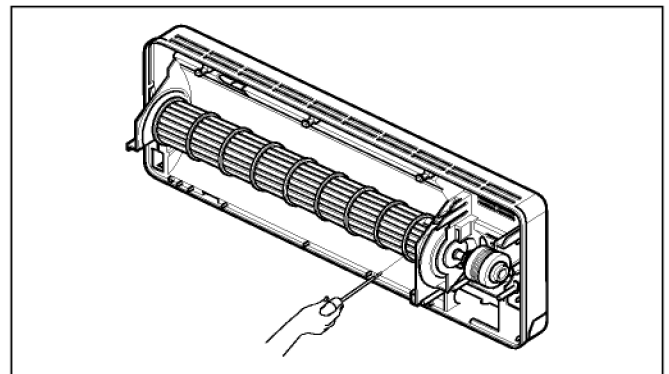

- Pull the left end of the cross-flow fan with the self-aligning bearing out the groove.
- Remove the cross-flow fan by sliding it out from the shaft of fan motor.

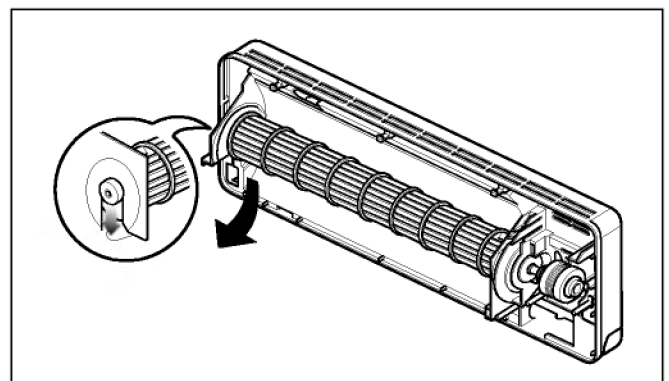

6. To remove the Fan Motor.

- Pick it up from the groove. (Do not remove a black rubber as a spacer).

2-way, 3-way Valve

		2-way Valve (Liquid Side)	3-way Valve (Gas Side or Liquid Side)	
Works		Shaft position	Shaft position	Service port
Shipping		Closed (with valve cap)	Closed (with valve cap)	Closed (with cap)
1.	Air purging (Installation)	Open (counter-clockwise)	Closed (clockwise)	Open (push-pin or with vacuum pump)
Operation		Open (with valve cap)	Open (with valve cap)	Closed (with cap)
2.	Pumping down (Transferring)	Closed (clockwise)	Open (counter-clockwise)	Open (connected manifold gauge)
3.	Evacuation (Servicing)	Open	Open	Open (with vacuum pump)
4.	Gas charging (Servicing)	Open	Open	Open (with charging cylinder)
5.	Pressure check (Servicing)	Open	Open	Open (with charging cylinder)
6.	Gas releasing (Servicing)	Open	Open	Open (with charging cylinder)

1. Air purging

Required tools: Hexagonal wrench, adjustable wrench, torque wrenches, wrench to hold the joints, and gas leak detector.

The additioner gas for air purging has been charged in the outdoor unit.

However, if the flare connections have not been done correctly and there gas leaks, a gas cylinder and the charge set will be needed.

The air in the indoor unit and in the piping must be purged. If air remains in the refrigeration pipes, it will affect the compressor, reduce to cooling capacity, and could lead to a malfunction.

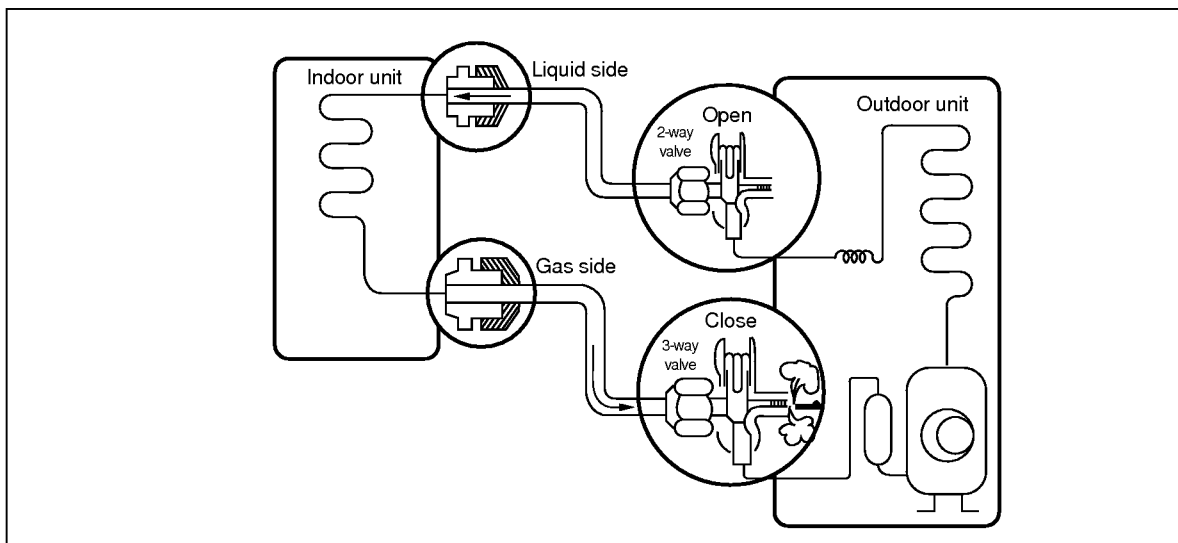

Service port nut.

Be sure, using a torque wrench to tighten the service port nut (after using the service port), so that it prevents the gas leakage from the refrigeration cycle.

CAUTION: Do not leak the gas in the air during Air purging.

• Procedure

(1) Recheck the piping connections.

(2) Open the valve stem of the liquid side valve counterclockwise approximately 90°, wait 10 seconds, and then set it to closed position.

- Be sure to use a hexagonal wrench to operate the valve stem.

(3) Check for gas leakage.

-Check the flare connections for gas leakage.

(4) Purge the air from the system.

- Set the liquid side valve to the open position and remove the cap from the gas side valve's service port.
- Using the hexagonal wrench to press the valve core pin, discharge for three seconds and then wait for one minute. Repeat this three times.

(5) Use torque wrench to tighten the service port nut to a torque of 1.8kg.cm.

(6) Set the gas side valve to the back seat.

(7) Mount the valve stem nuts to the gas side and liquid side valves.

(8) Check for gas leakage.

- At this time, especially check for gas leakage from the stem nuts of both valves and from the service port nut.

Caution

If gas leakage are discovered in step (3) above, take the following measures:

If the gas leaks stop when the piping connections are tightened further, continue working from step (4). If the gas leaks do not stop when the connections are retightened, repair the location of the leak, discharge all of the gas through the service port, and then recharge with the specified amount of gas from a gas cylinder.

2. Pumping down

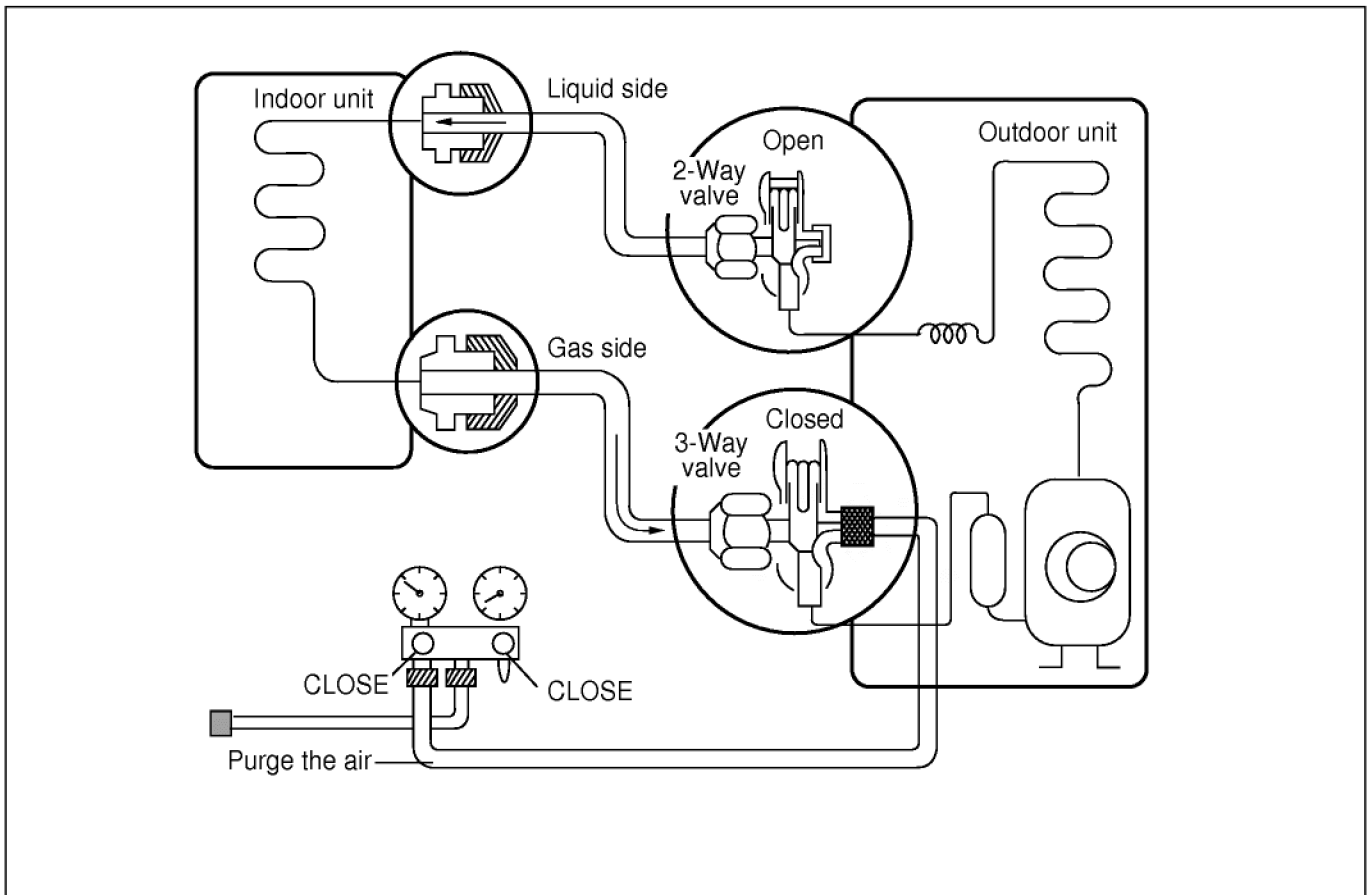

• Procedure

- (1) Confirm that both liquid side and gas side valves are set to the open position.**
 - Remove the valve stem caps and confirm that the valve stems are in the raised position.
 - Be sure to use a hexagonal wrench to operate the valve stems.
- (2) Operate the unit for 10 to 15 minutes.**
- (3) Stop operation and wait for 3 minutes, then connect the charge set to the service port of the 3-way valve.**
 - Connect the charge hose to the service port.
- (4) Air purging of the charge hose.**
 - Open the low-pressure valve on the charge set slightly to air purge from the charge hose.
- (5) Set the liquid side valve to the closed position.**
- (6) Operates the air conditioner in cooling mode and stop it when the gauge indicates 1kg/cm²g.**
- (7) Immediately set the 3-way valve to the closed position.**
 - Do this quickly so that the gauge ends up indicating 3 to 5kg/cm²g.
- (8) Disconnect the charge set, and mount the 2-way and 3-way valve's stem nuts and the service port nut.**
 - Use torque wrench to tighten the service port nut to a torque of 1.8kg.m.
 - Be sure to check for gas leakage.

1) Re-air purging (Re-installation)

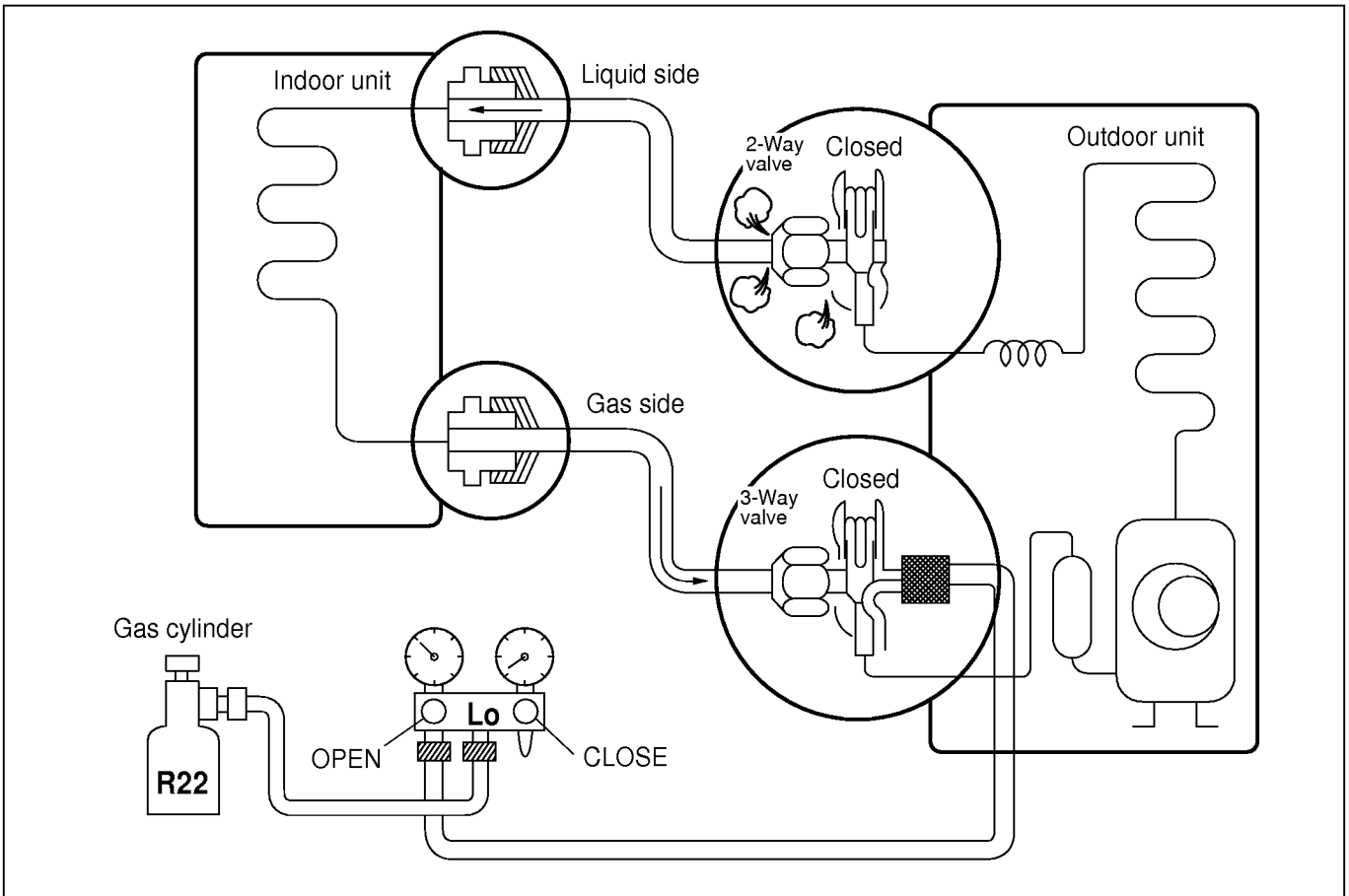

• Procedure

- (1) **Confirm that both the liquid side valve and the gas side valve are set to the closed position.**
- (2) **Connect the charge set and a gas cylinder to the service port of the 3-way valve.**
 - Leave the valve on the gas cylinder closed.
- (3) **Air purging.**
 - Open the valves on the gas cylinder and the charge set. Purge the air by loosening the flare nut on the liquid side valve approximately 45° for 3 seconds then closing it for 1 minute; repeat 3 times.
 - After purging the air, use a torque wrench to tighten the flare nut on liquid side valve.
- (4) **Check for gas leakage.**
 - Check the flare connections for gas leakage.
- (5) **Discharge the refrigerant.**
 - Close the valve on the gas cylinder and discharge the refrigerant until the gauge indicates 3 to 5 kg/cm²g.
- (6) **Disconnect the charge set and the gas cylinder, and set the 2-way and 3-way valves to the open position.**
 - Be sure to use a hexagonal wrench to operate the valve stems.
- (7) **Mount the valve stem nuts and the service port nut.**
 - Use torque wrench to tighten the service port nut to a torque of 1.8 kg.m.
 - Be sure to check for gas leakage.

CAUTION:

Do not leak the gas in the air during Air Purging.

2) Balance refrigerant of the 2-way, 3-way valves (Gas leakage)

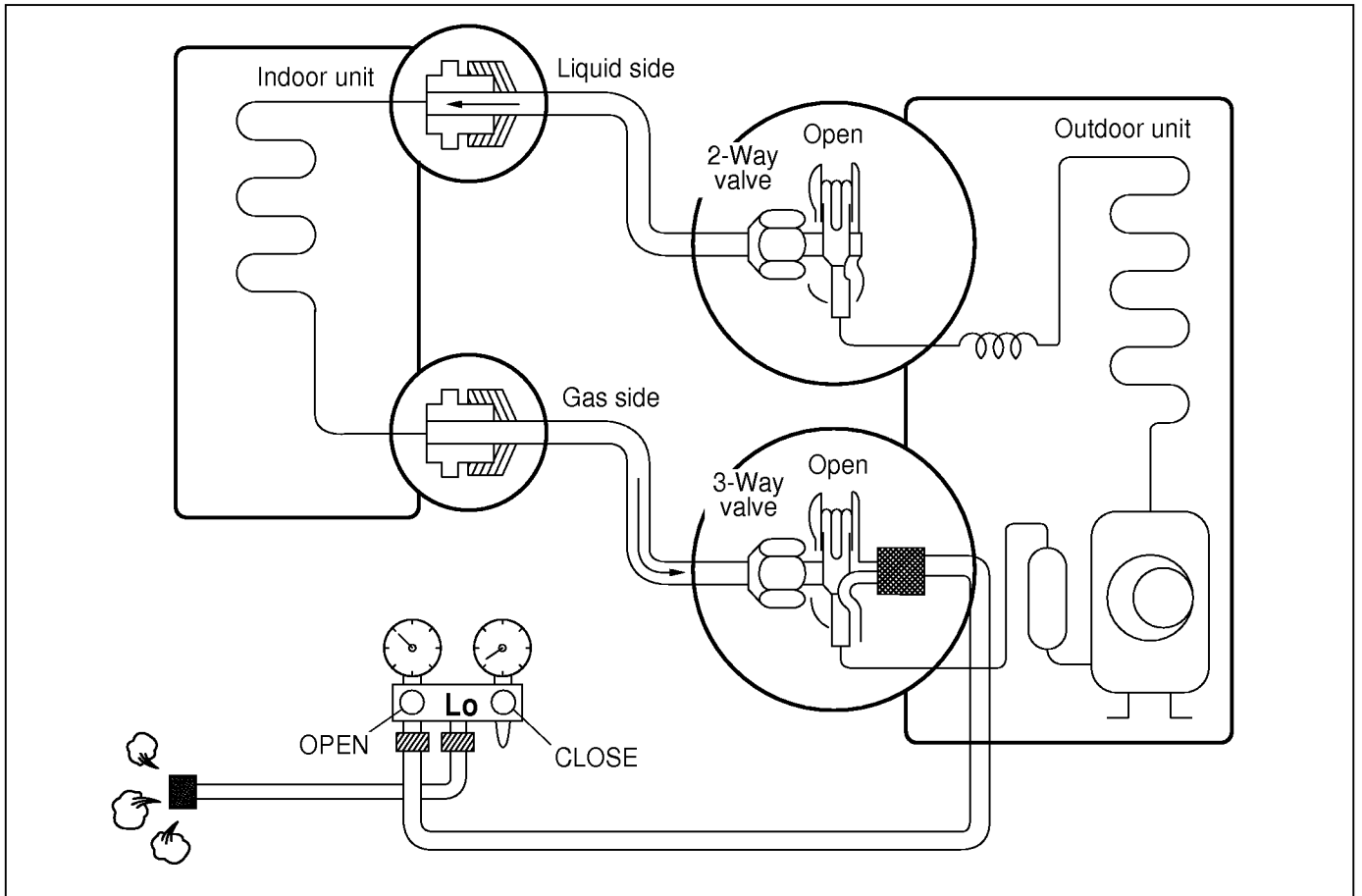

• Procedure

- (1) Confirm that both the liquid side and gas side valves are set to the back seat.
- (2) Connect the charge set to the 3-way valve's port.
 - Leave the valve on the charge set closed.
 - Connect the charge hose to the service port.
- (3) Open the valve (Lo side) on the charge set and discharge the refrigerant until the gauge indicates 0 kg/cm²G.
 - If there is no air in the refrigerant cycle (the pressure when the air conditioner is not running is higher than 1 kg/cm²G), discharge the refrigerant until the gauge indicates 0.5 to 1 kg/cm²G. If this is the case, it will not be necessary to apply an evacuation.
 - Discharge the refrigerant gradually; if it is discharged too suddenly, the refrigeration oil will also be discharged.

3. Evacuation

(All amount of refrigerant leaked)

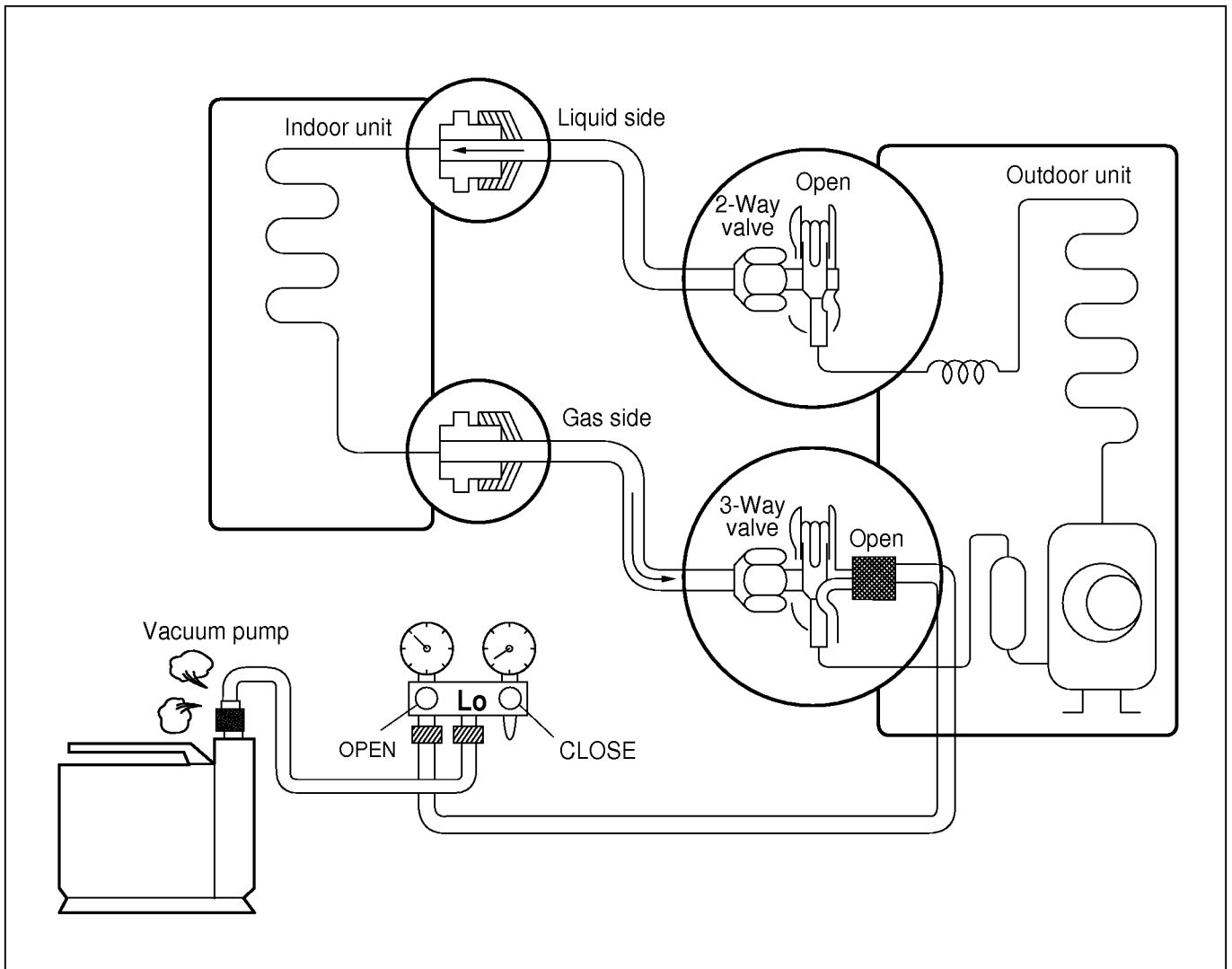

• Procedure

- (1) Connect the vacuum pump to the center hose of charge set center hose
- (2) Evacuation for approximately one hour.
 - Confirm that the gauge needle has moved toward -76cmHg (vacuum of 4 mmHg or less).
- (3) Close the valve (Lo side) on the charge set, turn off the vacuum pump, and confirm that the gauge needle does not move (approximately 5 minutes after turning off the vacuum pump).
- (4) Disconnect the charge hose from the vacuum pump.
 - Vacuum pump oil.
 - If the vacuum pump oil becomes dirty or depleted, replenish as needed.

4. Gas Charging (After Evacuation)

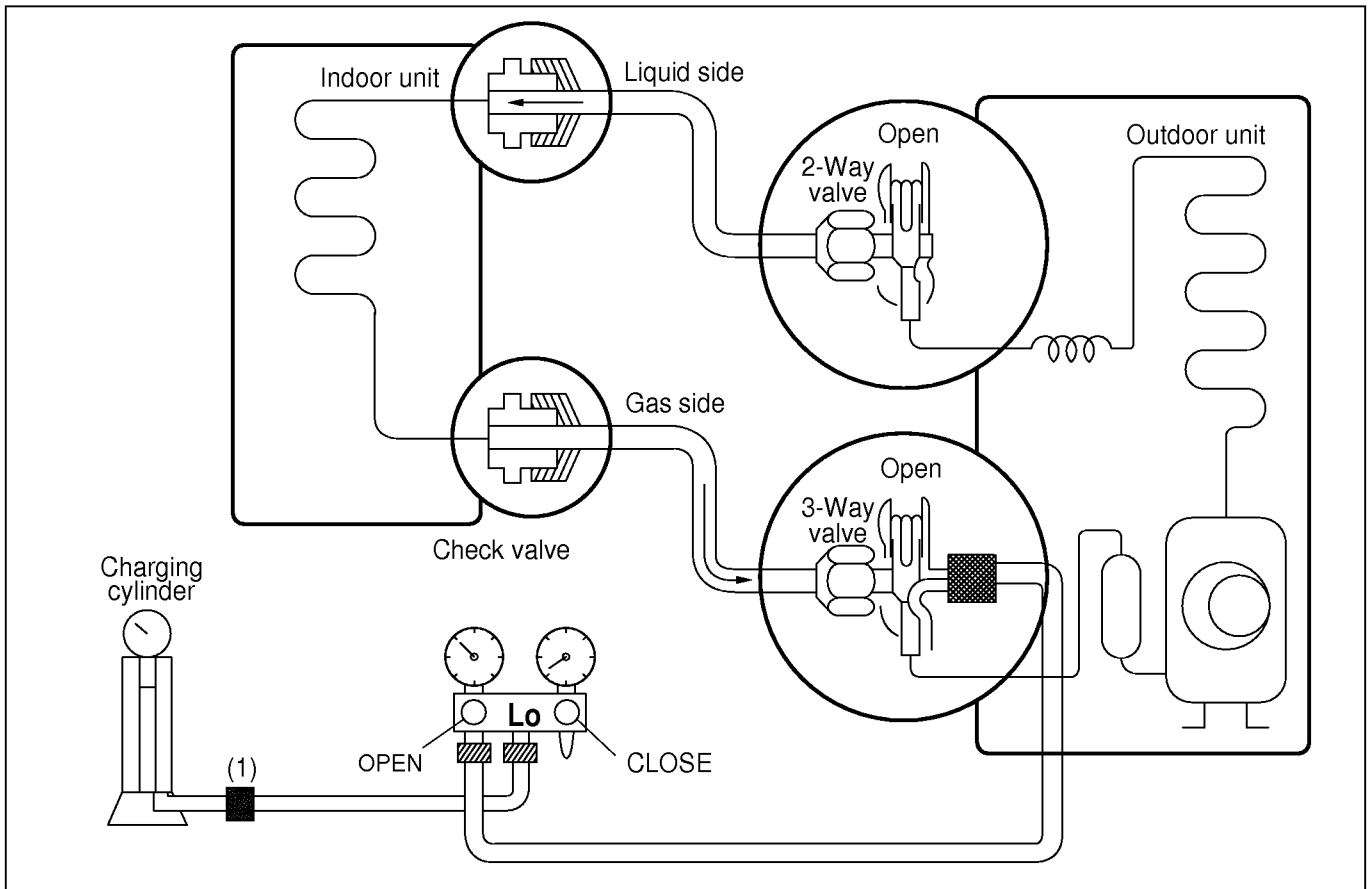

• Procedure

(1) Connect the charge hose to the charging cylinder.

- Connect the charge hose which you disconnected from the vacuum pump to the valve at the bottom of the cylinder.
- If you are using a gas cylinder, also use a scale and reverse the cylinder so that the system can be charged with liquid.

(2) Purge the air from the charge hose.

- Open the valve at the bottom of the cylinder and press the check valve on the charge set to purge the air. (Be careful of the liquid refrigerant). The procedure is the same if using a gas cylinder.

(3) Open the valve (Lo side) on the charge set and charge the system with liquid refrigerant.

- If the system can not be charged with the specified amount of refrigerant, it can be charged with a little at a time (approximately 150g each time) while operating the air conditioner in the cooling cycle; however, one time is not sufficient, wait approximately 1 minute and then repeat the procedure (pumping down-pin).

This is different from previous procedures. Because you are charging with liquid refrigerant from the gas side, absolutely do not attempt to charge with larger amounts of liquid refrigerant while operating the air conditioner.

(4) Immediately disconnect the charge hose from the 3-way valve's service port.

- Stopping partway will allow the gas to be discharged.
- If the system has been charged with liquid refrigerant while operating the air conditioner turn off the air conditioner before disconnecting the hose.

(5) Mount the valve stem nuts and the service port nut.

- Use torque wrench to tighten the service port nut to a torque of 1.8 kg.m.
- Be sure to check for gas leakage.

Cycle Troubleshooting Guide

Trouble analysis

1. Check temperature difference between intake and discharge air and operating current.

Temp. Difference	Temp. difference : approx. 0°C Current : less than 80% of rated current	All amount of refrigerant leaked out. Check refrigeration cycle.
	Temp. difference : approx. 8°C Current : less than 80% of rated current	Refrigerant leakage Clog of refrigeration cycle Defective compressor
Operating Current	Temp. difference : less than 8°C Current : over the rated current	Excessive amount of refrigerant
	Temp. difference : over 8°C	Normal

Notice:

Temperature difference between intake and discharge air depends on room air humidity. When the room air humidity is relatively higher, temperature difference is smaller. When the room air humidity is relatively lower temperature difference is larger.

2. Check temperature and pressure of refrigeration cycle.

Suction pressure (Compared with the normal value)	Temperature (Compared with the normal value)	Cause of Trouble	Description
Higher	High	Defective compressor Defective 4-way reverse valve	Current is low.
	Normal	Excessive amount of refrigerant	High pressure does not quickly rise at the beginning of operation.
Lower	Higher	Insufficient amount of refrigerant(Leakage)	Current is low.
		Clogging	Current is low.

Notice:

1. The suction pressure is usually 4.5~6.0 kg/cm²G at normal condition.
2. The temperature can be measured by attaching the thermometer to the low pressure tubing and wrap it with putty.

Electronic Parts Troubleshooting Guide

WARNING:

1. When servicing the unit, remove the power cord of outdoor unit.
2. The FAN MOTOR of outdoor unit operates intermittently for the reliability of the unit during operation.

Possible Trouble 1 : The unit does not operate.

1) Check Outdoor Unit

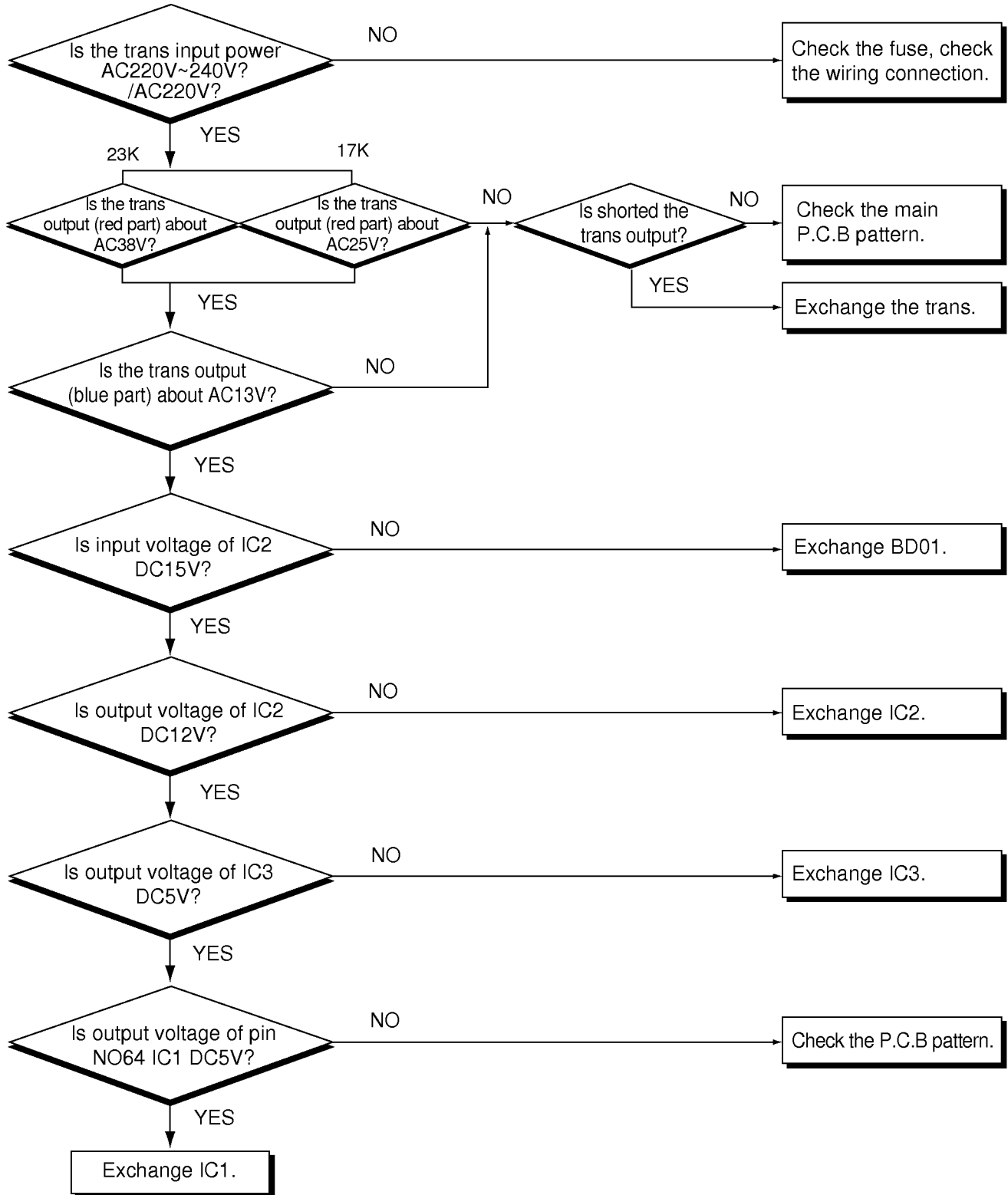

2) Check Indoor Unit

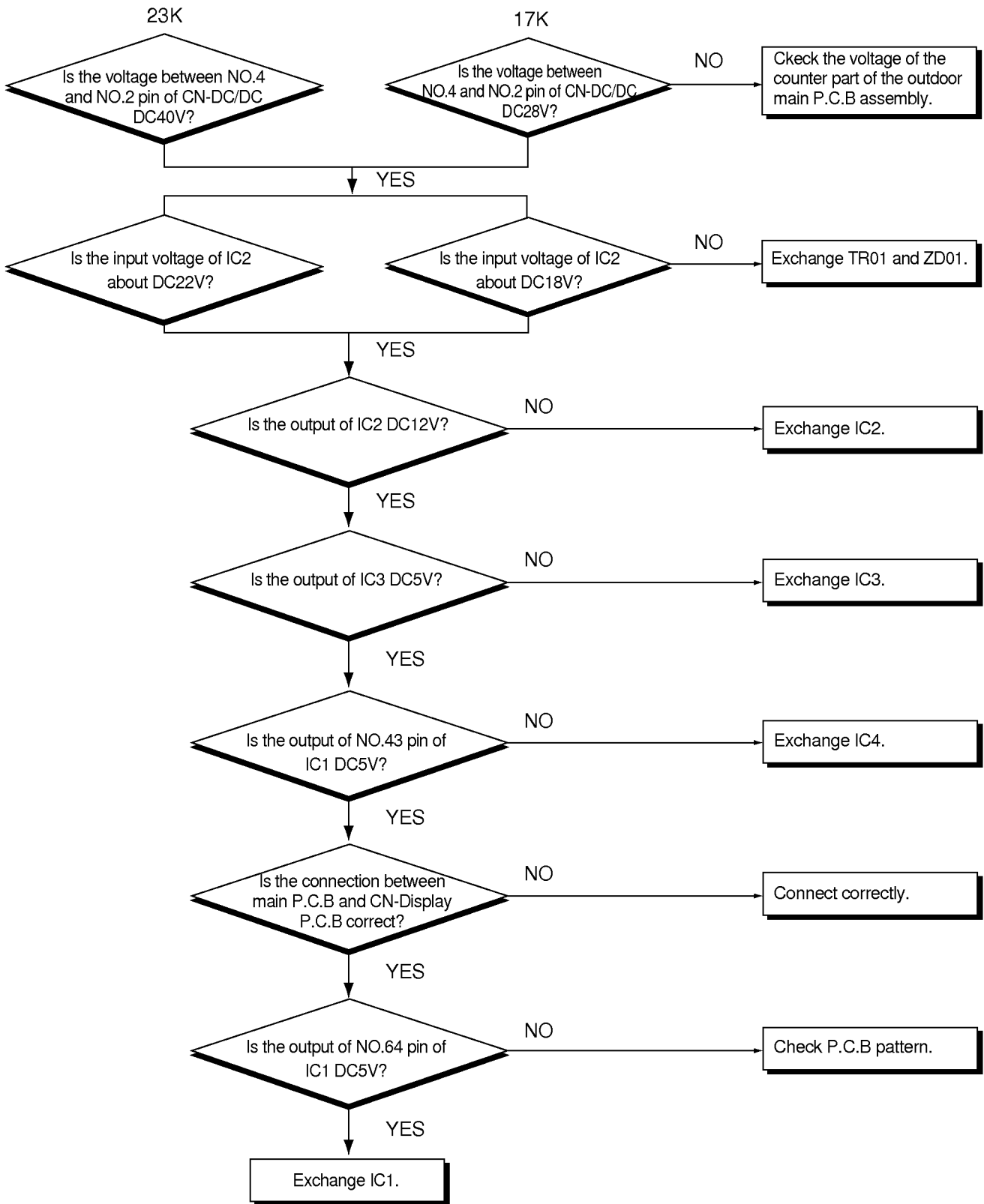

Possible Trouble 2

: Indoor fan does not operate.

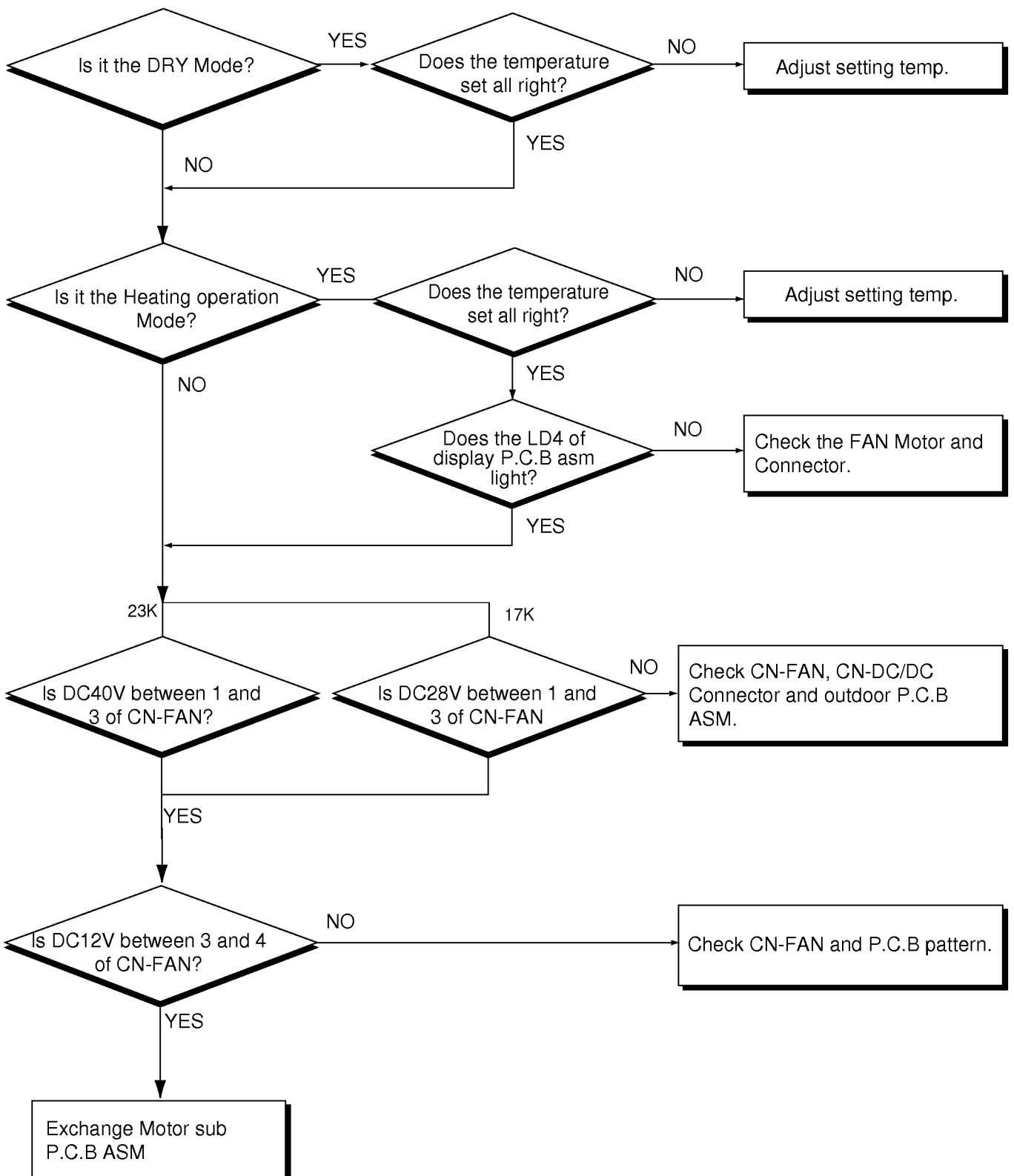

Possible Trouble 3

: Right/Left air direction louver does not operate.

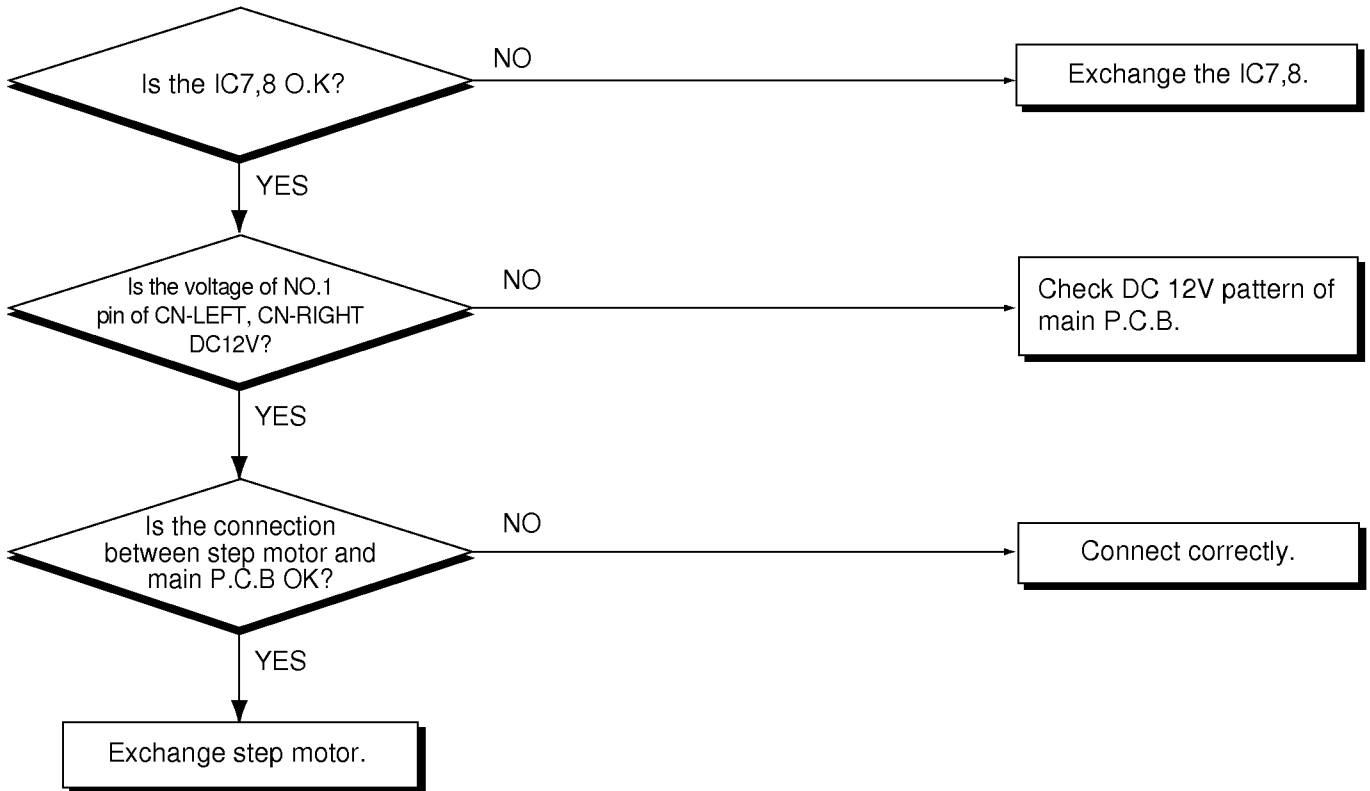

Possible Trouble 4

: Up/Down air direction louver does not operate.

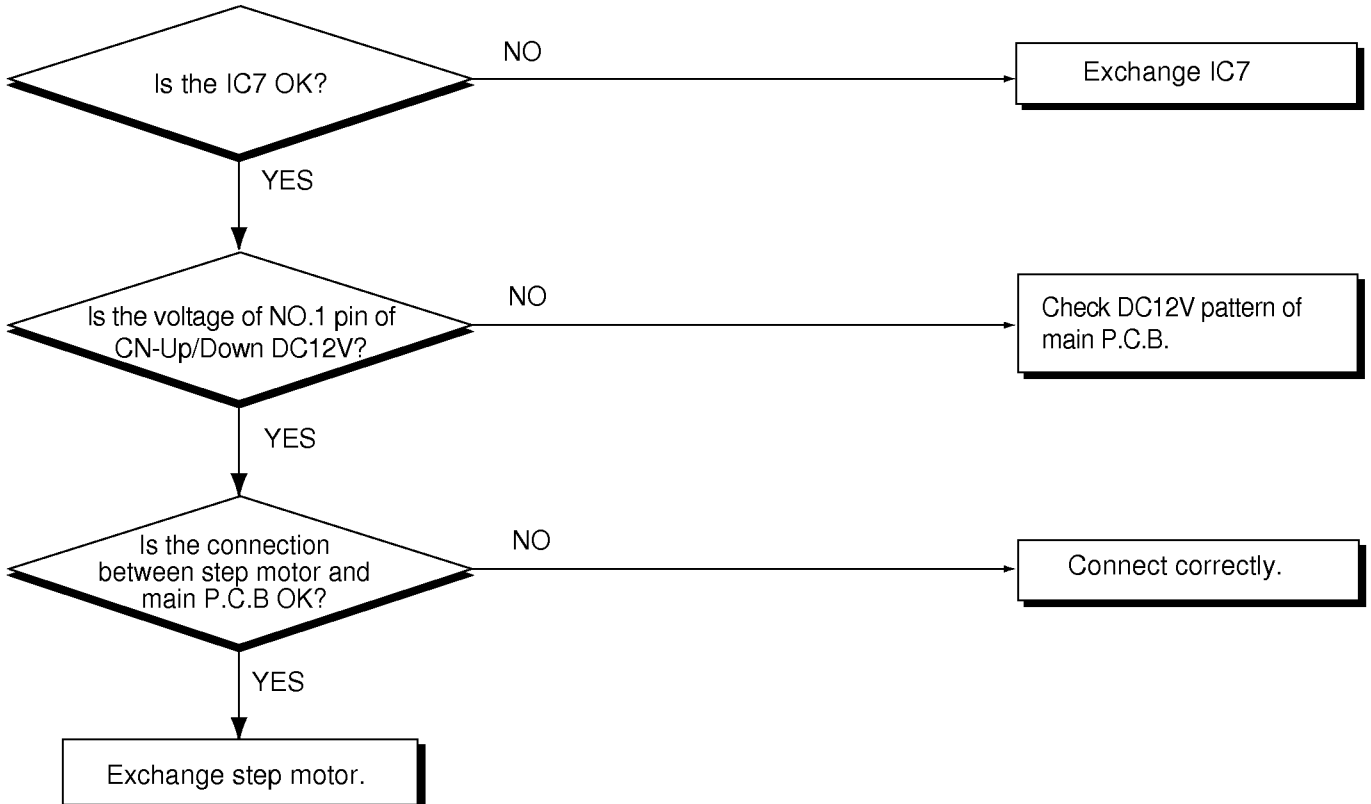

Possible Trouble 5

: Remote controller does not operate.

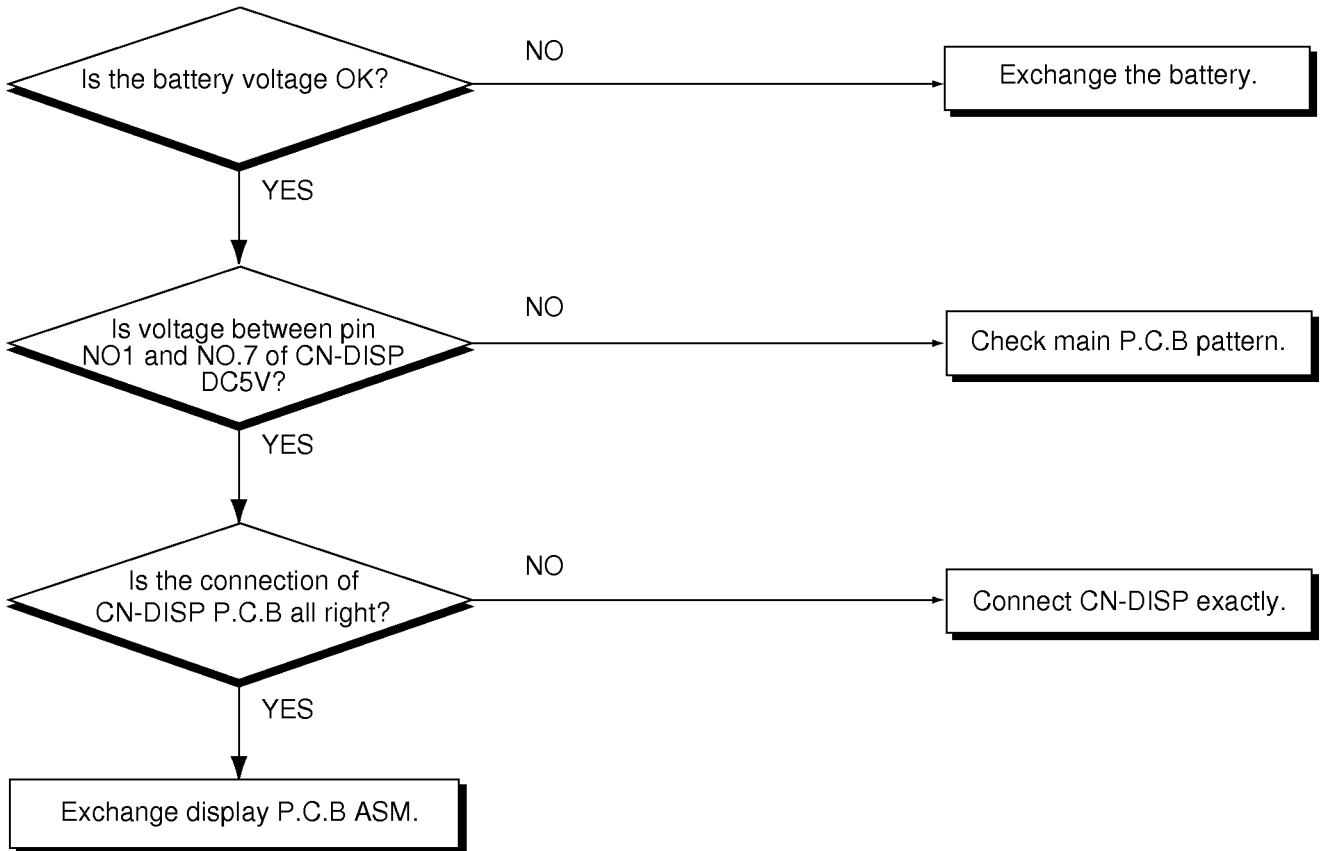

Possible Trouble 6

: Forced operation key does not work.

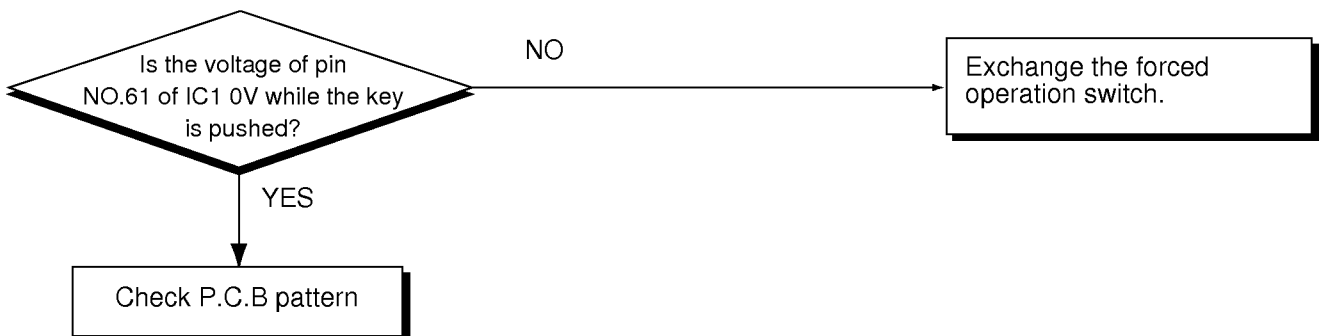

Possible Trouble 7

: Heating operation does not work.

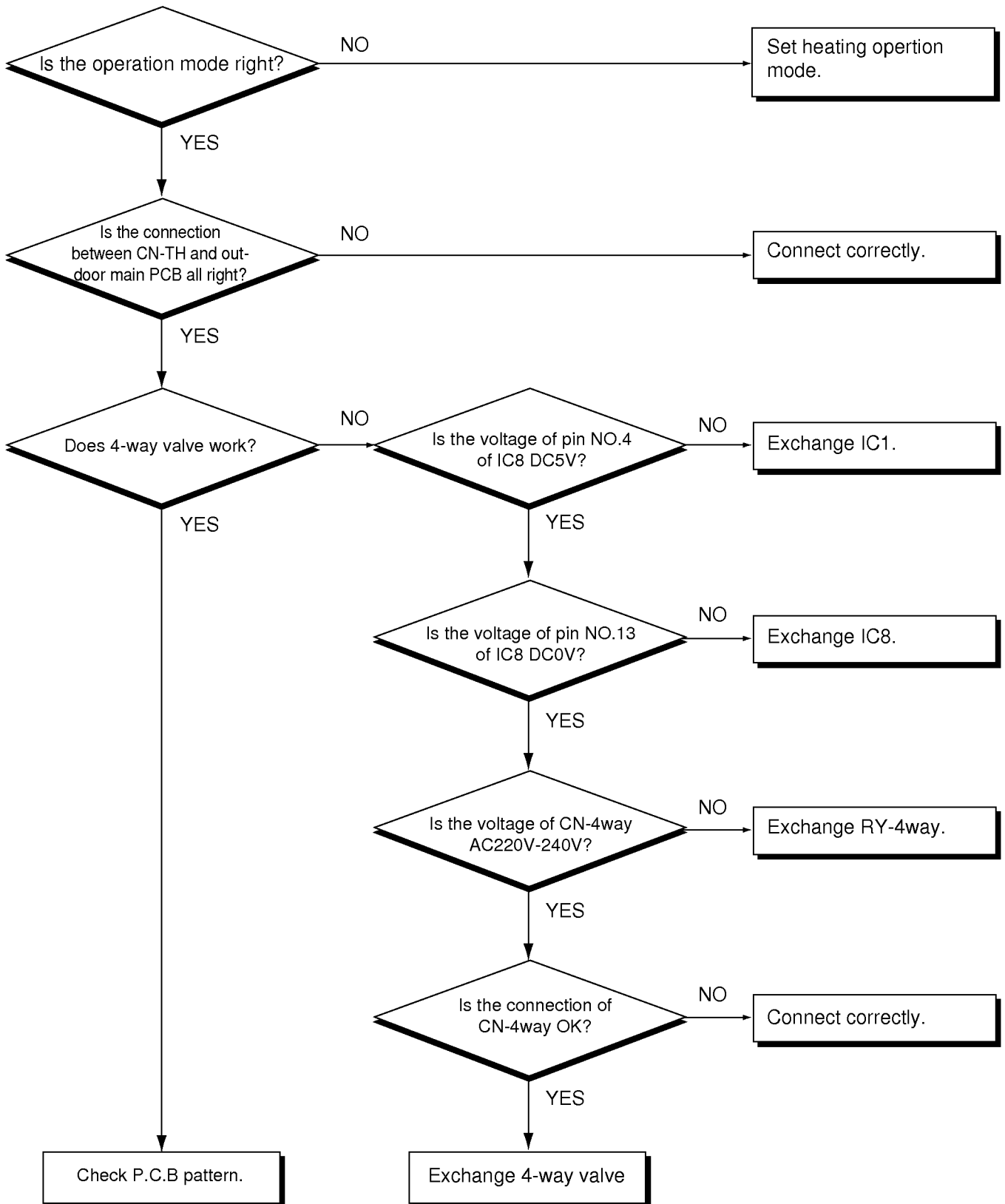

Electronic Control Device

(1) MAIN P.C.B ASM (Indoor Unit)

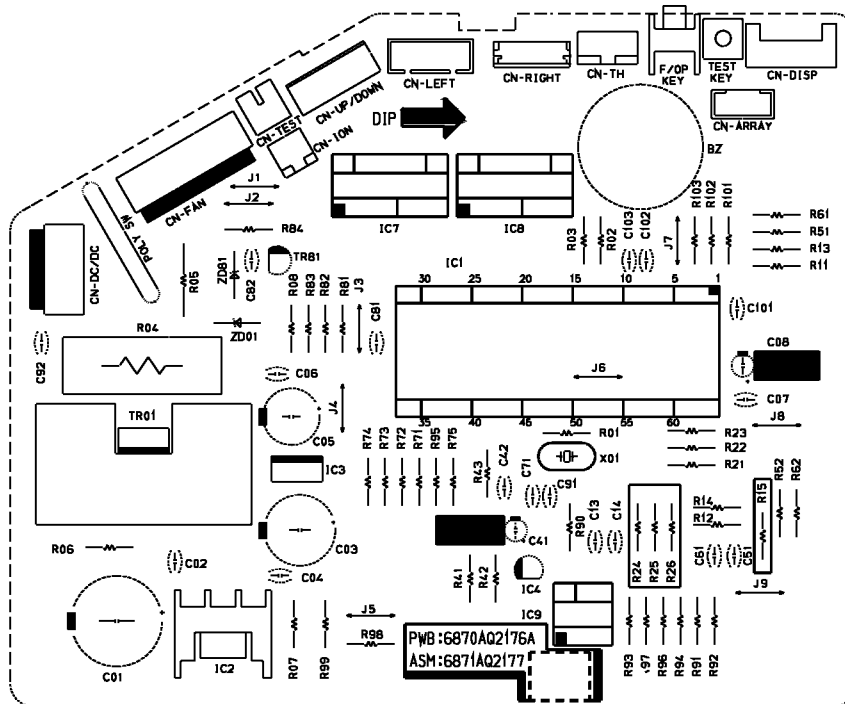

• P.C.B ASM LIST

NO	MODEL	P/No.	OPTIONAL FUNCTION						
			R13	R24	R25	R26	CN-LEFT	CN-RIGHT	CN-ION
1	AG1AC23BKM	6871AQ2177Y	5.3KF	14.3KF	21KF	SHORT	NO	NO	NO
2	AG1AC23BWF/G/I	6871AQ2177P	6.2KF	14.3KF	32.4KF	OPEN	NO	NO	NO
3	AG1AH23BWF/G/I	6871AQ2177R	6.2KF	OPEN	32.4KF	OPEN	NO	NO	NO
4	AG1AH17BWF/G/I	6871AQ2177T	6.2KF	OPEN	4.7KF	SHORT	NO(OPTION)	NO(OPTION)	NO(OPTION)
5	AG1AC17BWF/G/I AG1AC17BKM	6871AQ2177U	6.2KF	14.3KF	4.7KF	SHORT	NO(OPTION)	NO(OPTION)	NO(OPTION)

(3) MOTOR SUB P.C.B ASM (P/No.: 6871AQ3089A)

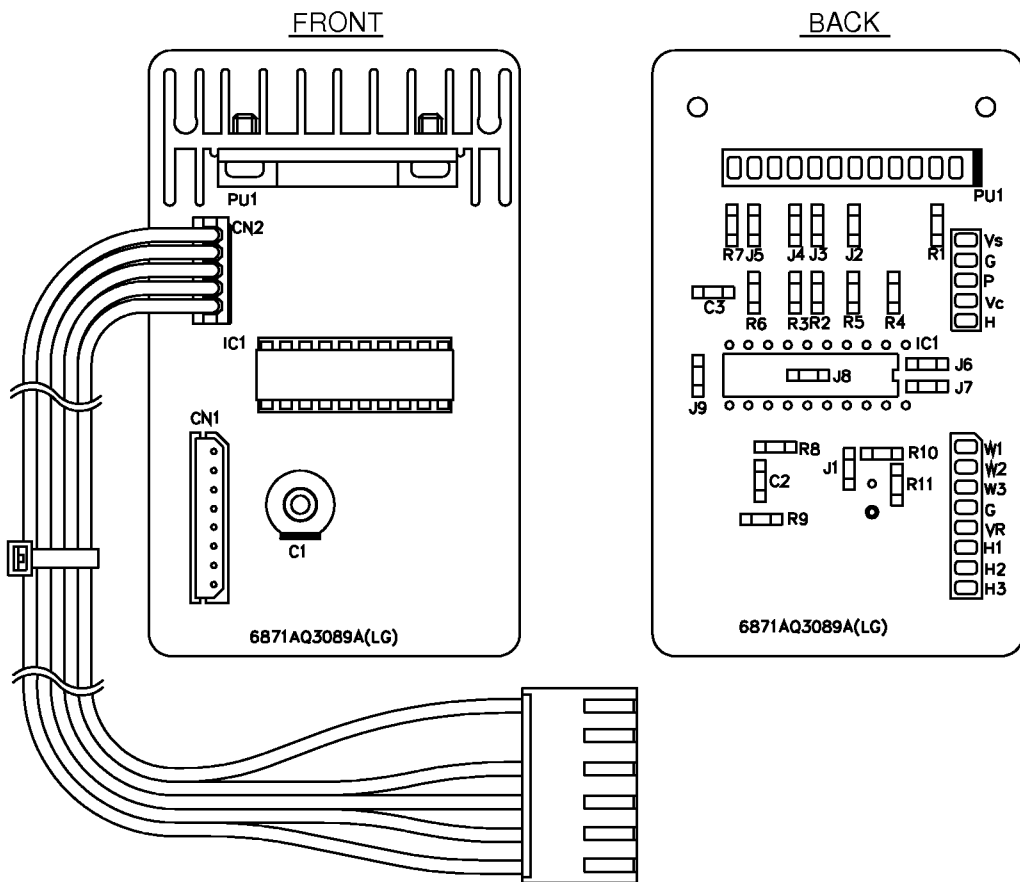

(4) DISPLAY P.C.B ASM (P/No.: 6047AQ3029C)

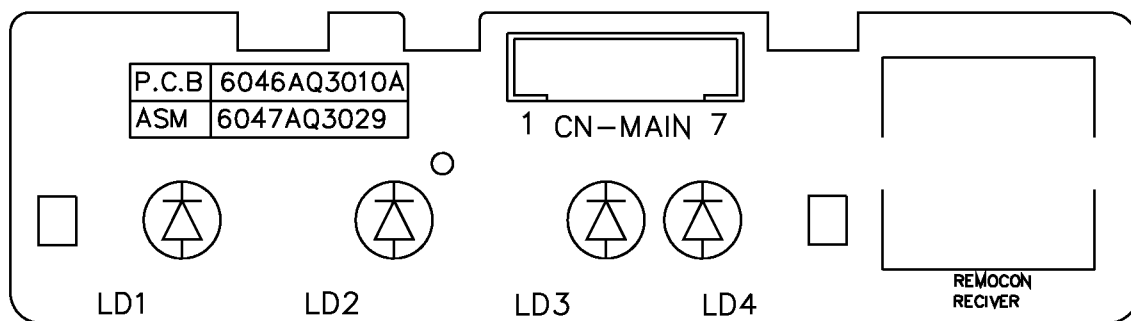

• AG1AH17BWF/G/I, AG1AH23BWF/G/I

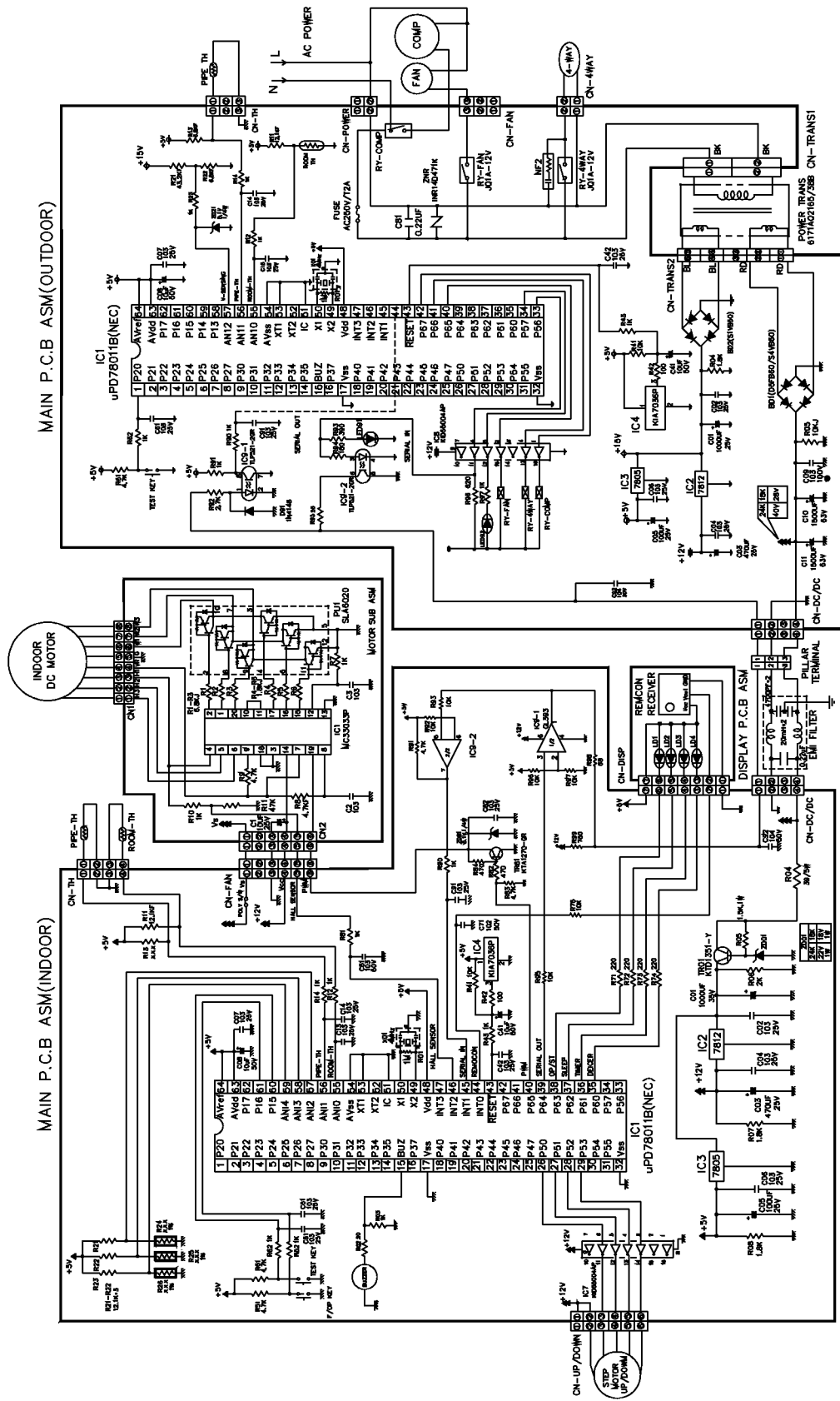

• AG1AC23BKM

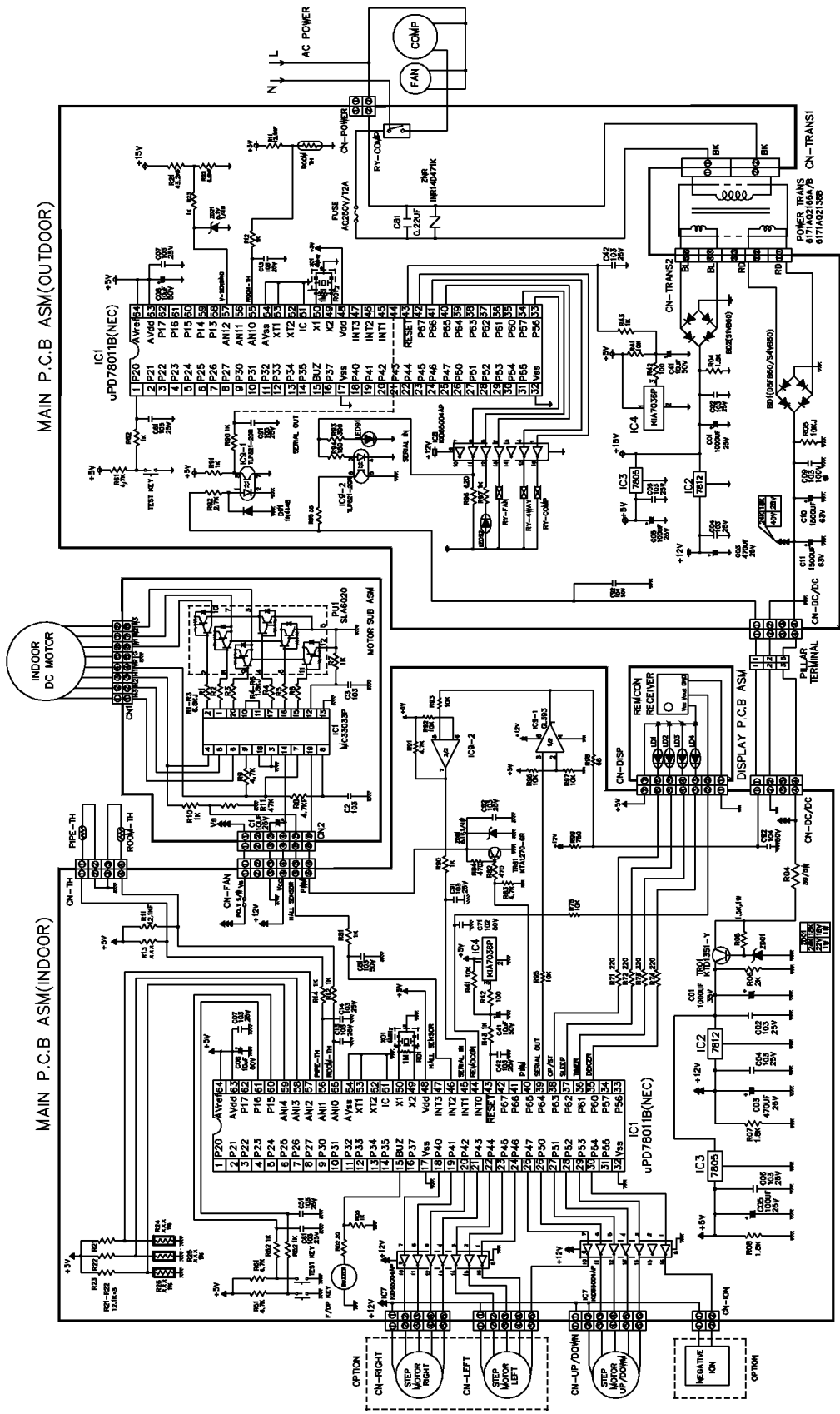

• AG1AC23BWF/G/I

