

Installation

1. Installation of Indoor, Outdoor unit

1) Selection of the best location

1. Indoor unit

- There should not be any heat source or steam near the unit.
- There should not be any obstacles to prevent the air circulation.
- A place where air circulation in the room will be good.
- A place where drainage can be easily obtained.
- A place where noise prevention is taken into consideration.
- Do not install the unit near the door way.
- Ensure the spaces indicated by arrows from the wall, ceiling, fence, or other obstacles.

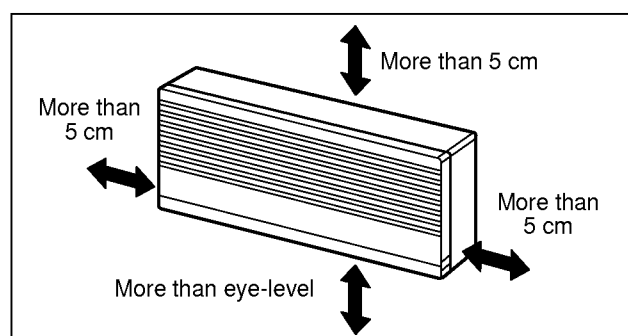
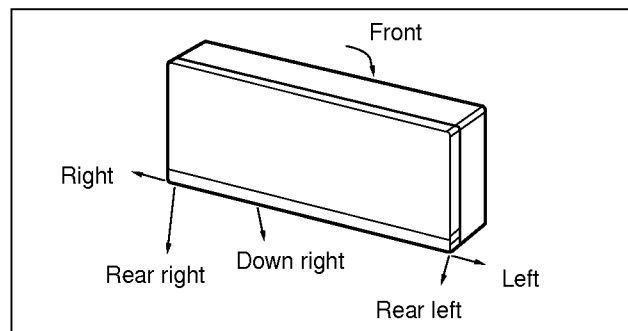

2. Outdoor unit

- If an awning is built over the unit to prevent direct sunlight or rain exposure, be careful that heat radiation from the condenser is not restricted.
- There should not be any animals or plants which could be affected by hot air discharged.
- Ensure the spaces indicated by arrows from the wall, ceiling, fence, or other obstacles.

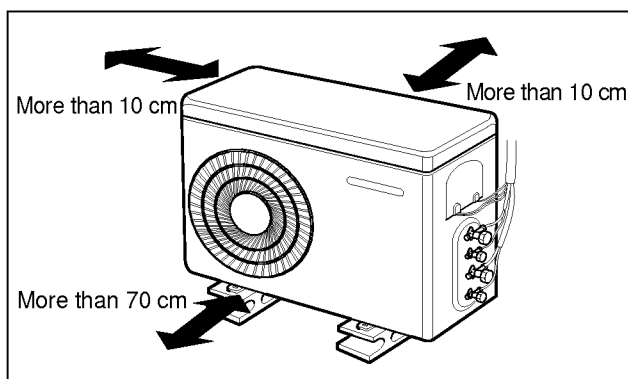

3. Piping length and the elevation

	Pipe Size		Max. piping length A (m)	Max. Elevation B (m)
	GAS	LIQUID		
AG5AC21BWF01 AG5AH21BWF01	3/8", 1/2"	1/4"	7	5

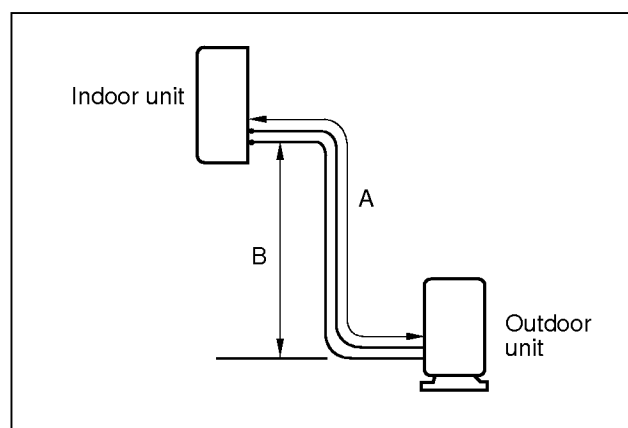

2) Indoor Unit Installation

The mounting wall should be strong and solid enough to prevent it from vibration.

1. Mount the installation plate on the wall with four Type "A" screws.

- Always mount the Installation plate horizontally by aligning the marking-off line with using the thread and a level.

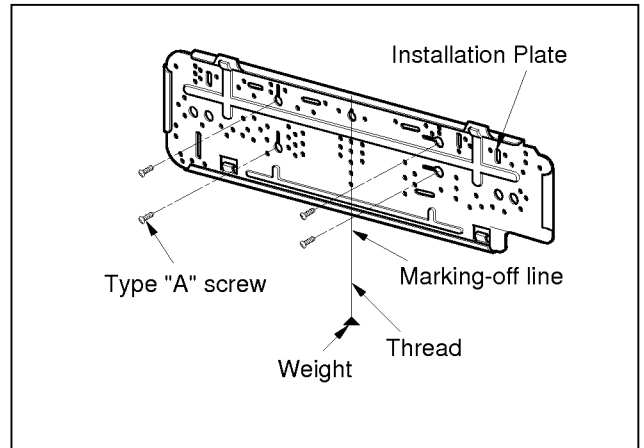

2. Drill the piping hole with 70mm dia. holecore drill.

- Drill the piping hole at either the right or the left and the hole should be slightly slant to the outdoor side.

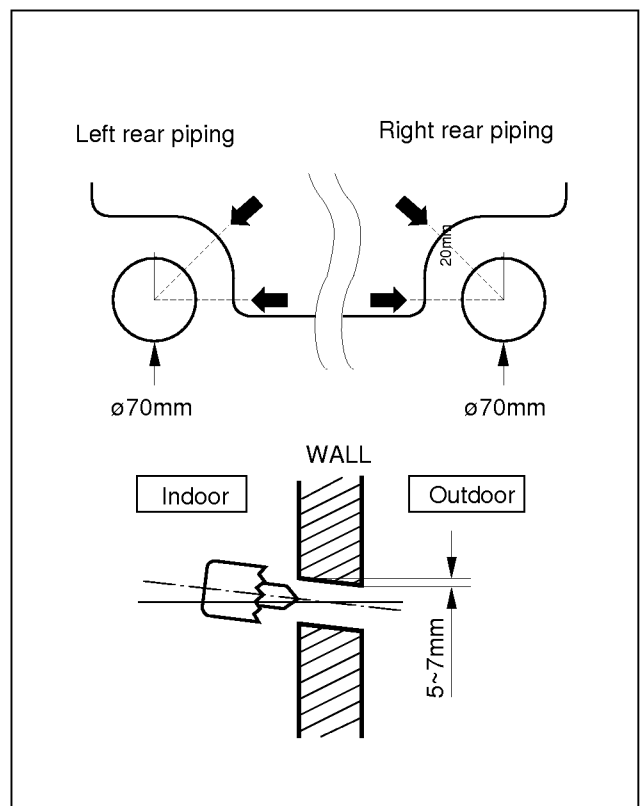

2. Piping and Drainage of Indoor Unit

1) Preparation of pipings

1. Cut the pipes and the cable.

- Use the accessory piping kit or the pipes purchased locally.
- Measure the distance between the indoor and the outdoor unit.
- Cut the pipes a little longer than the measured distance.
- Cut the cable 1.5m longer than the length of the pipe.

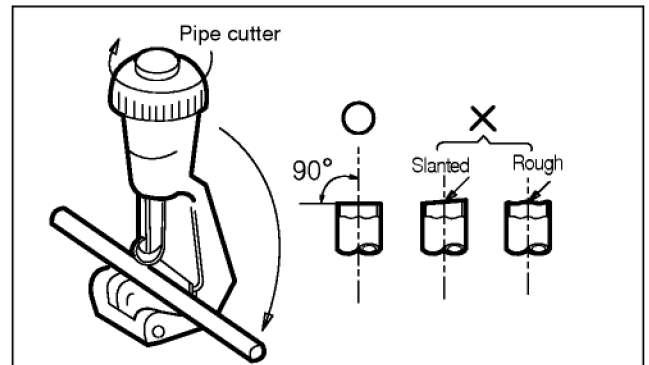

2. Remove burrs.

- Remove burrs from cut edges of pipes.
- Turn the pipe end toward down to avoid the metal powder entering the pipe.

Caution:

If burrs are not removed, they may cause a gas leakage.

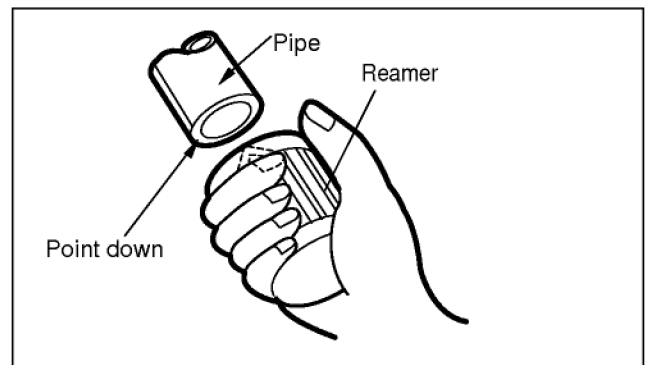

3. Flaring the pipes.

- Insert the flare nuts, mounted on the connection ports of both indoor and outdoor unit, onto the copper pipes. Some refrigerant gas may leak, when the flare nuts are removed from the indoor unit, as some gas is charged to prevent the inside of the pipe from rusting.
- Fit the copper pipe end into the Bar of flare tool about 0.5~1.0mm higher. (See illustration)
- Flare the pipe ends.

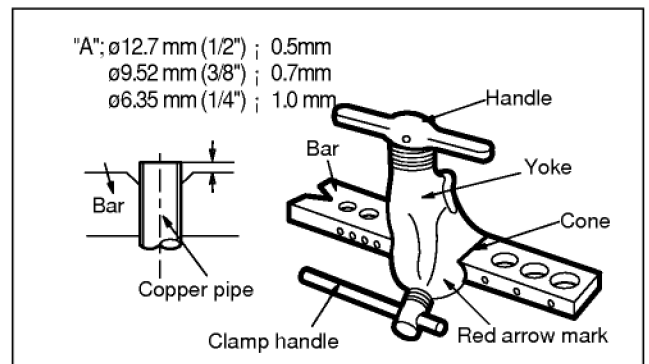

4. Tape the flaring portion to protect it from the dust or damages.

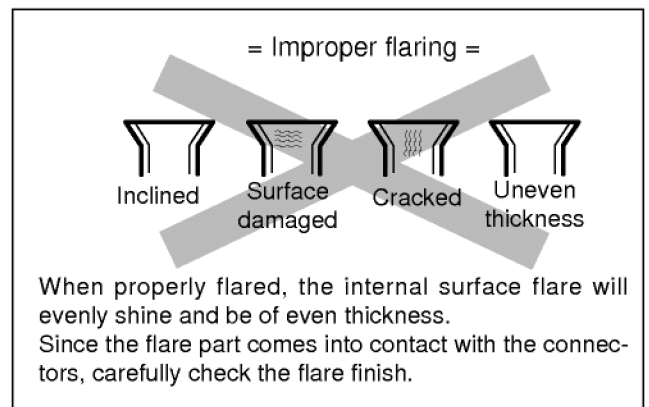

2) Connection of Pipings

1. Remove the indoor tubing with Drain hose to the hole.

- Remove tubing holder and pull the tubing out of the chassis.

2. Refix the tubing holder into original position.

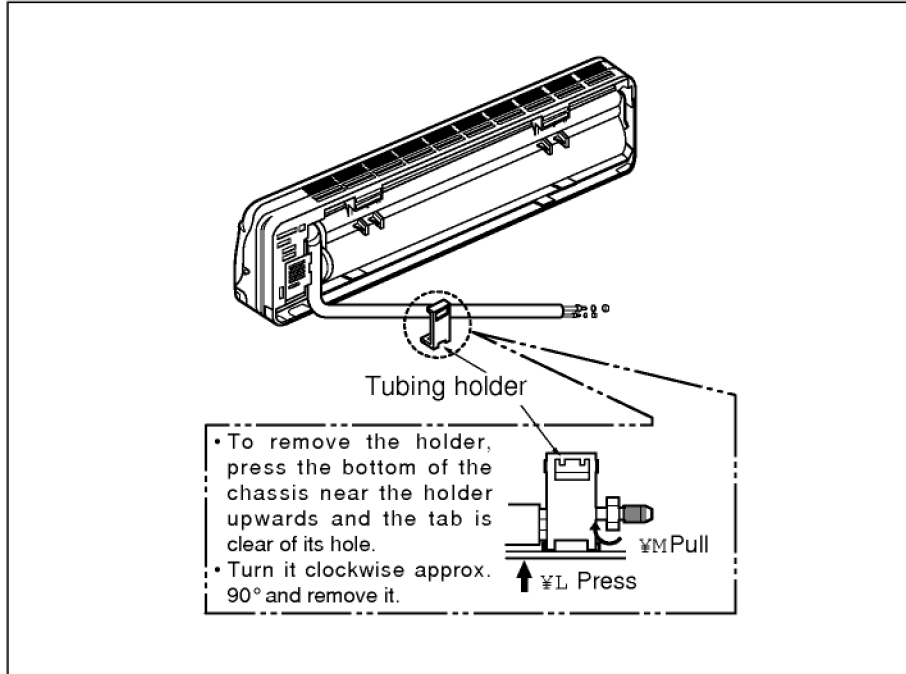

For right rear piping

3. Route the tubing and the drain hose straight backwards(see figure).

4. Insert the connecting cable into the indoor unit through the piping hole.

- Don't connect the cable to the indoor unit.
- Make a small loop with the cable for easy connection later.

5. Tape the tubing, drain hose and the connecting cable.

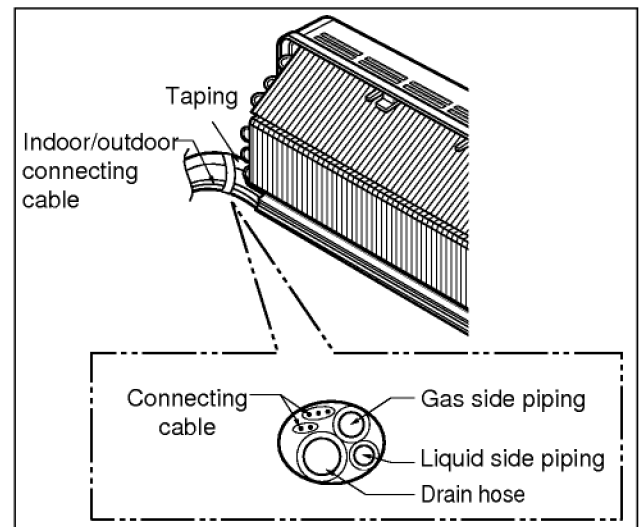
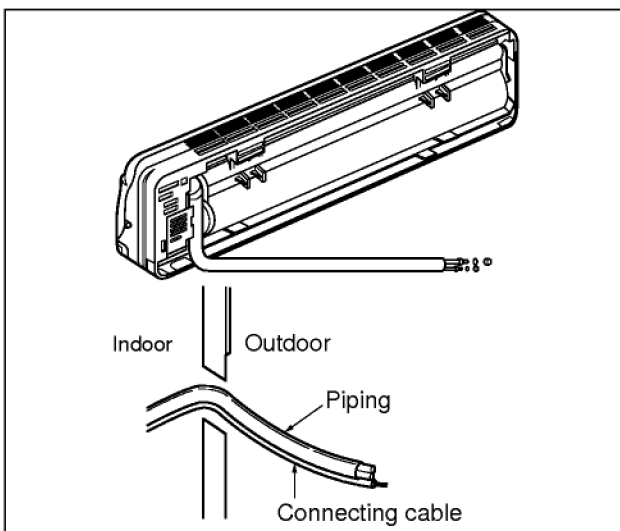

6. Indoor unit installation.

- Hook the indoor unit onto the upper position of the installation plate. (Engage the two hooks of the rear top of the indoor unit with the upper edge of the installation plate.)
Ensure the hooks are properly seated on the installation plate by moving it in left and right.

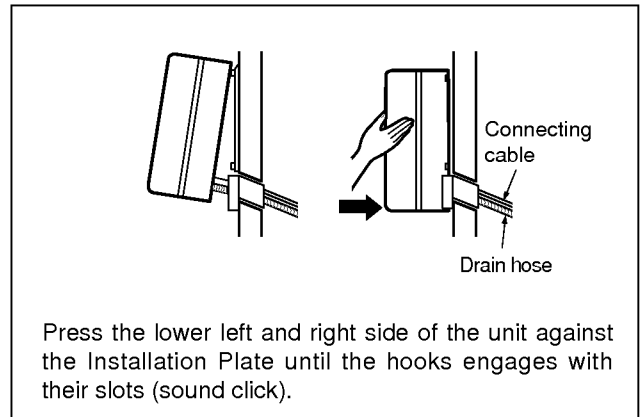

7. Connecting the pipings to the indoor unit.

- Align the center of the pipings and sufficiently tighten the flare nut with fingers.
- Finally, tighten the flare nut with torque wrench until the wrench clicks.
Wrench tightening the flare nut with torque wrench, ensure the direction for tightening follows the arrows on the wrench.

Pipe Size	Torque
Liquid Side (1/4")	1.8kg _i ·m
Gas Side (3/8")	4.2kg _i ·m
Gas Side (1/2")	5.5kg _i ·m

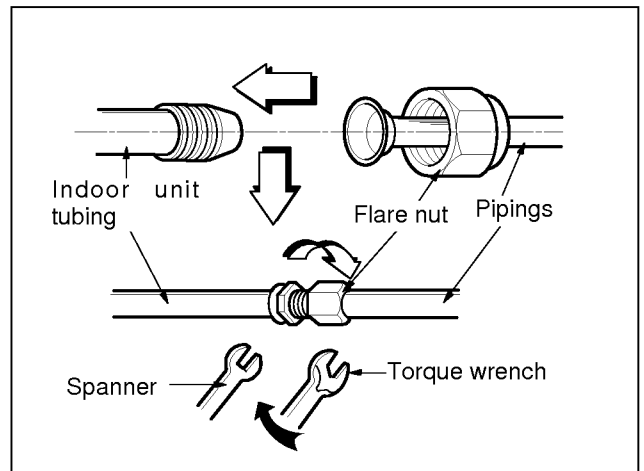

8. Wrap the insulation material around the connecting portion.

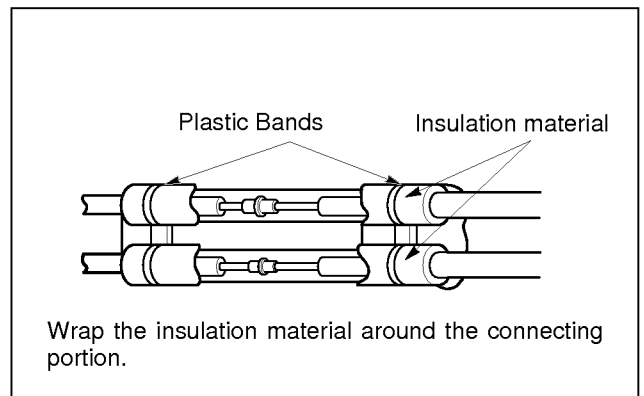

For left rear pipings

3. Route the indoor tubing with the drain hose to the piping hole as desired position.

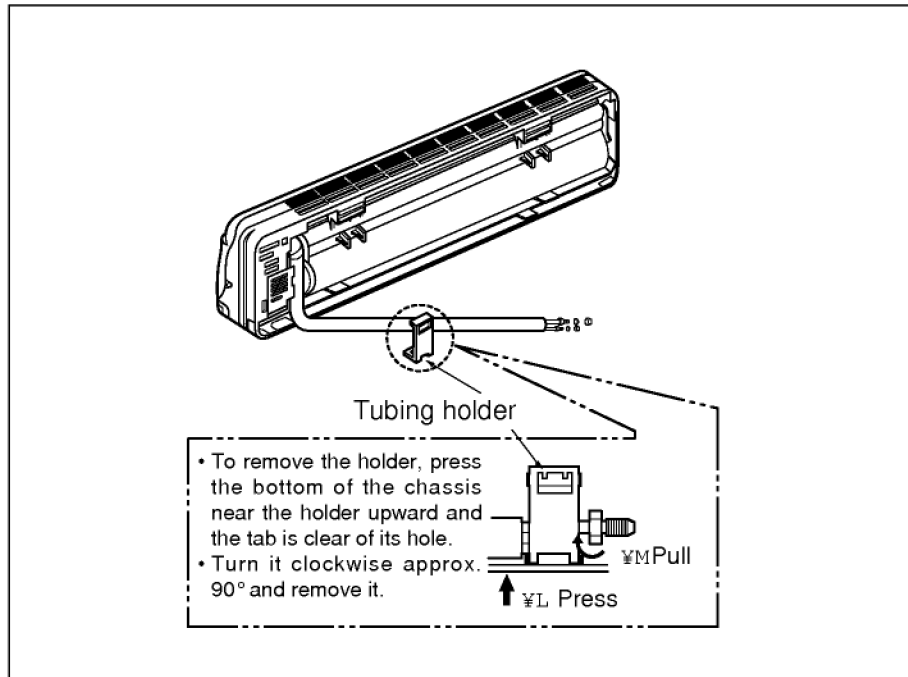

4. Insert the pipings and the connecting cable into the piping hole.

5. Insert the connecting cable into the indoor unit.

- Don't connect the cable to the indoor unit.
- Make a small loop with the cable for easy connection later.

6. Tape the tubing, drain hose and the connecting cable.

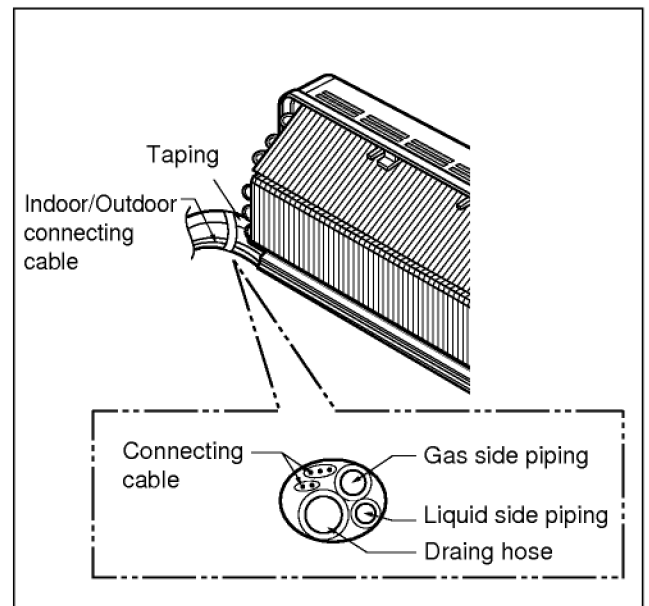
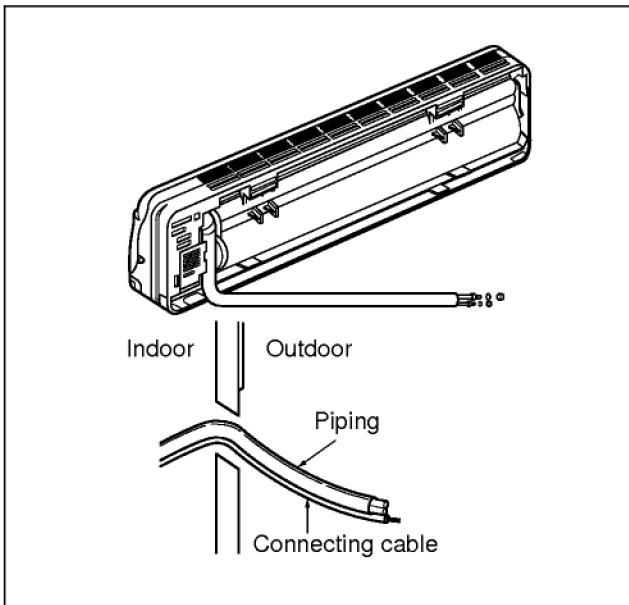

7. Indoor unit installation

- Hook the indoor unit onto the upper position of installation plate. (Engage the two hooks of the rear top of the indoor unit with the upper edge of the installation plate.)
Ensure the hooks are properly seated on the installation plate by moving it in left and right.

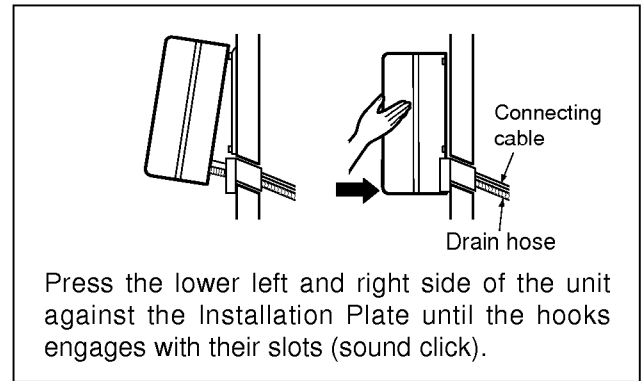

8. Connecting the pipings to the indoor unit

- Align the center of the pipings and sufficiently tighten the flare nut with fingers.
- Finally, tighten the flare nut with torque wrench until the wrench clicks.
Wrench tightening the flare nut with torque wrench, ensure the direction for tightening follows the arrows on the wrench.

Pipe Size	Torque
Liquid Side (1/4")	1.8kg _i ·m
Gas Side (3/8")	4.2kg _i ·m
Gas Side (1/2")	5.5kg _i ·m

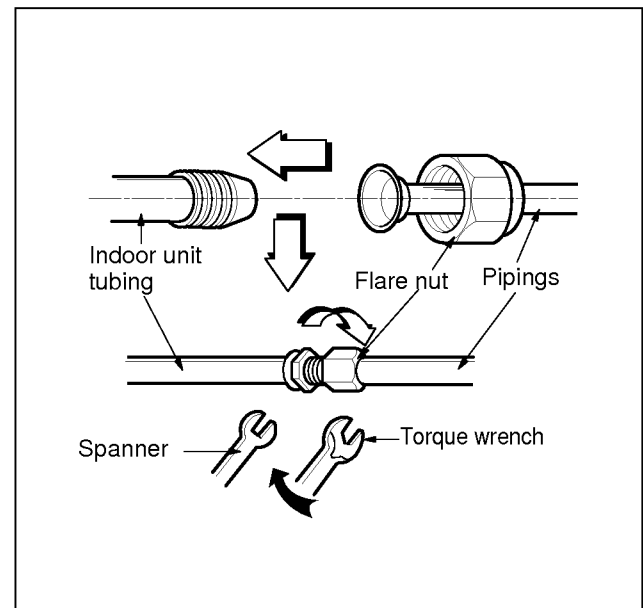

9. Wrap the insulation material around the connecting portion.

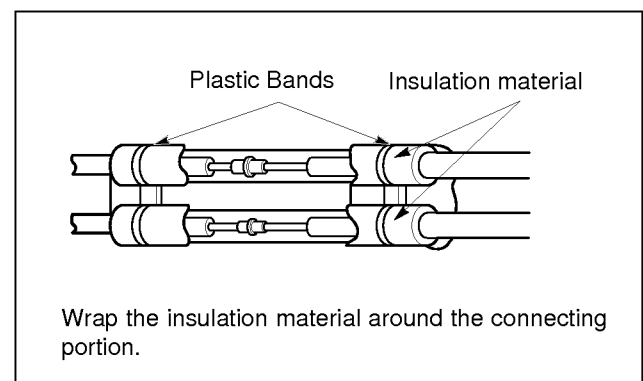

3. Connecting Pipings and the cable to Outdoor unit

1) Connecting the pipings to the Outdoor unit

1. Align the center of the pipings and sufficiently tighten the flare nut with fingers.
2. Finally, tighten the flare nut with torque wrench until the wrench clicks.
 - When tightening the flare nut with torque wrench, ensure the direction for tightening follows the arrow on the wrench.

Pipe Size	Torque
Liquid Side (1/4")	1.8kg _i ·m
Gas Side (3/8")	4.2kg _i ·m
Gas Side (1/2")	5.5kg _i ·m

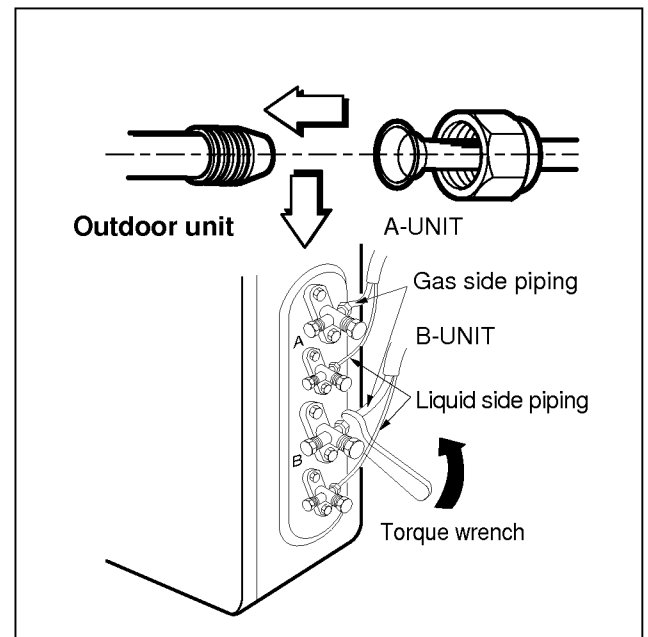

2) Connection of the cable

1. Remove the control board cover from the unit by loosening the screw.
Connect the wires to the terminals on the control board individually.

1) Cooling only type

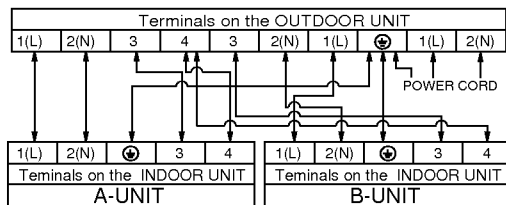

2) Cooling & Heating type

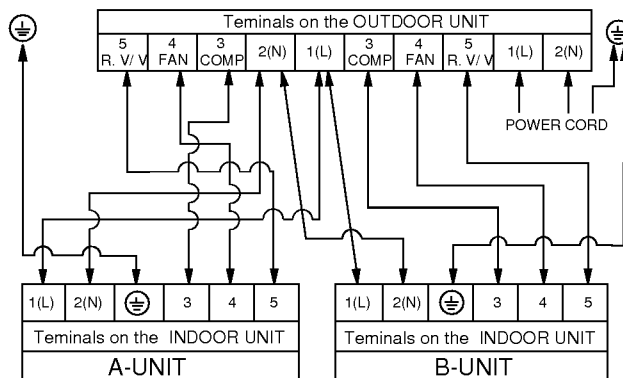

2. Secure the cable onto the control board with the holder (clamer).
3. Attach the control board cover to the original position with the screw.
4. Use a recognized circuit breaker 25A between the power source and the unit. A disconnection device to adequately disconnect all supply lines must be fitted.

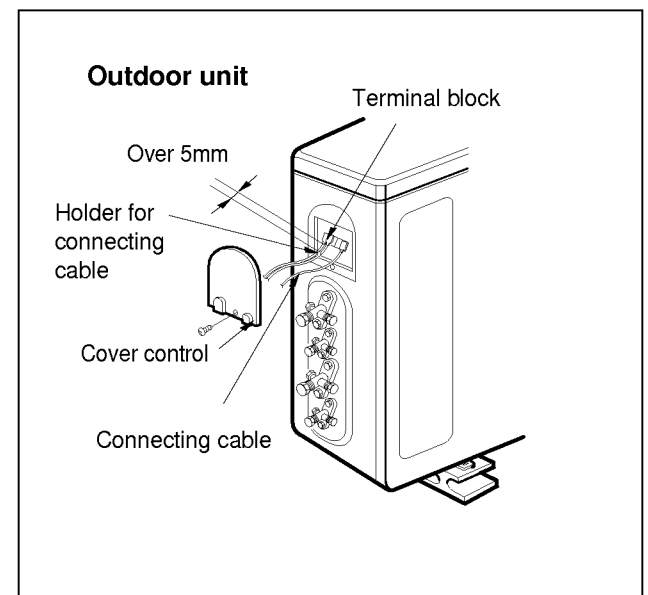

The power cord connected to the outdoor unit should be complied with the following specifications (Rubber insulation, type H05RN-F approved by TUV or VDE)

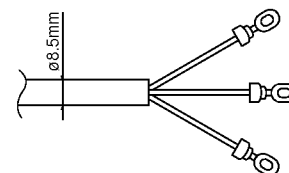

NOMINAL CROSS-SECTIONAL AREA
2.5mm²

4. Checking the Drainage and Pipe forming

1) Checking the Drainage

1. Remove the Grille from the cabinet

- Set the up-and-down air direction louver to open position(horizontally) by finger pressure.
- Remove the securing screws.
- To remove the Grille, pull lower the left and right side of the grille toward you (slightly tilted) and lift it straight upward.

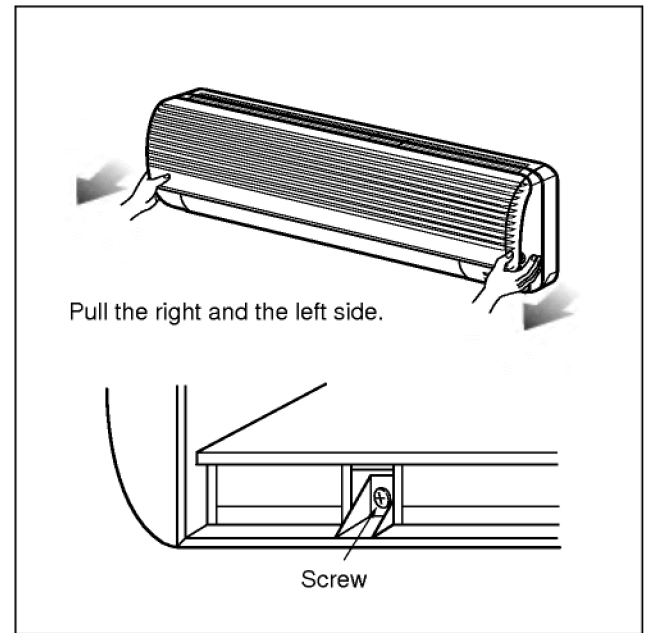

2. Check the drainage

- Pour a glass of water on the evaporator.
- Ensure if water flows drain hose of indoor unit.

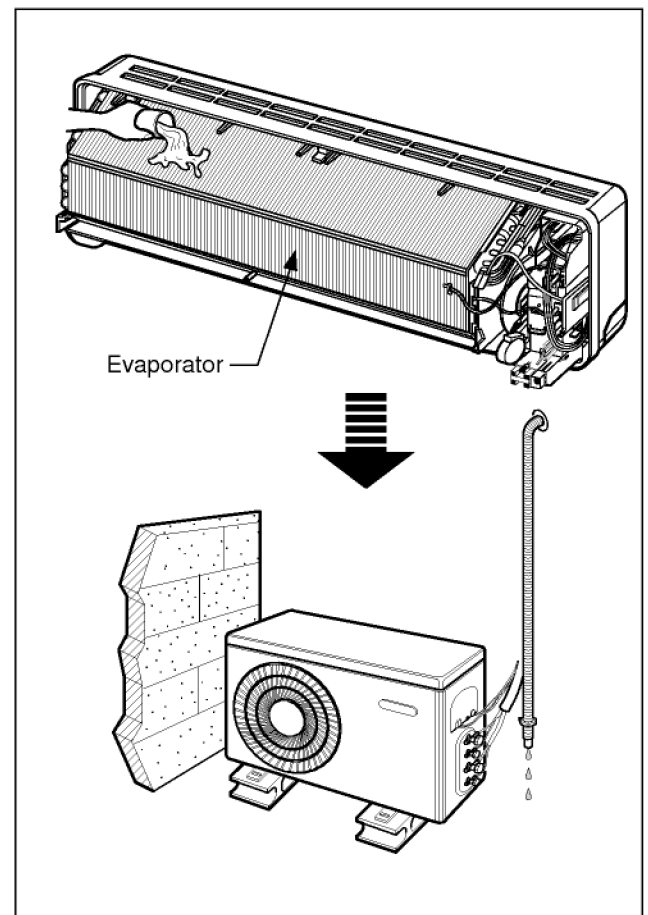

2) Connect the cable to the indoor unit

1. Connect the wires to the terminals on the control board individually according to the outdoor unit connection.

- Ensure the color of wires of outdoor unit and the terminal No.s are the same to the indoor's respectively.

1) Cooling only type

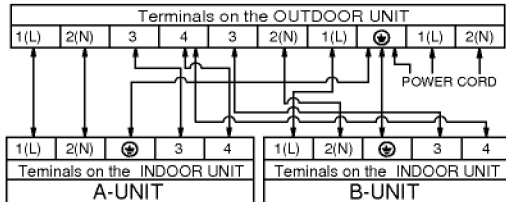

2) Cooling & Heating type

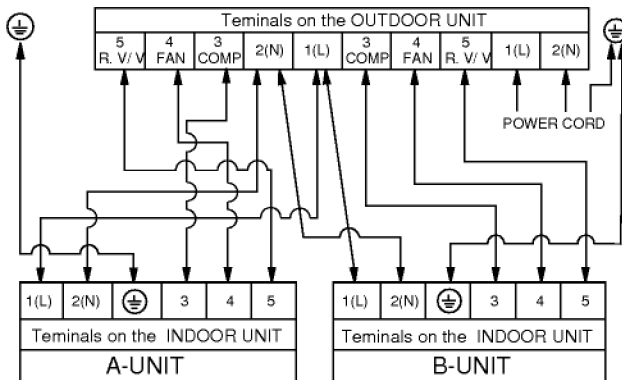

- Secure the cable onto the control board with the holder (clammer).

2. Attach the Grille onto the cabinet.

- Grasp the lower left and right side of the grille and engage two tabs on the top inside edge of the grille with two slots on the cabinet's top front edge.
- Press the Grille toward to the cabinet until it will be back into place.
- Secure the grille to the cabinet with two screws.

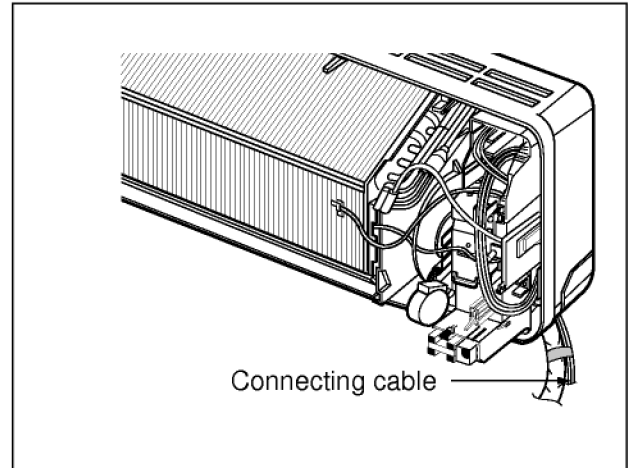

The connecting cable, from the indoor unit to the outdoor unit should be complied with the following specification.(Rubber insulation, type H05RN-F approved by TUV or VDE)

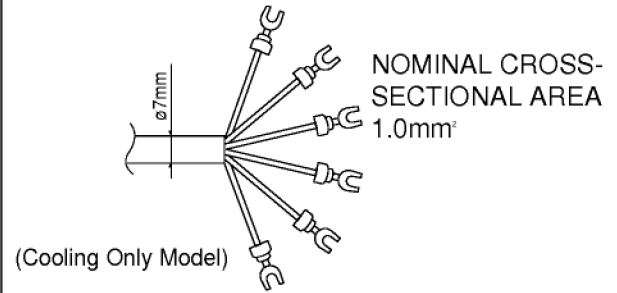

The connecting cable, from the indoor unit to the outdoor unit should be complied with the following specification.(Rubber insulation, type H05RN-F approved by TUV or VDE)

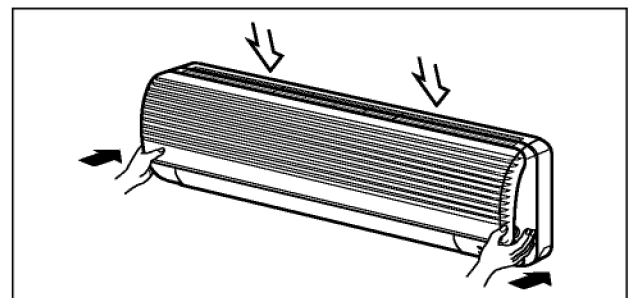
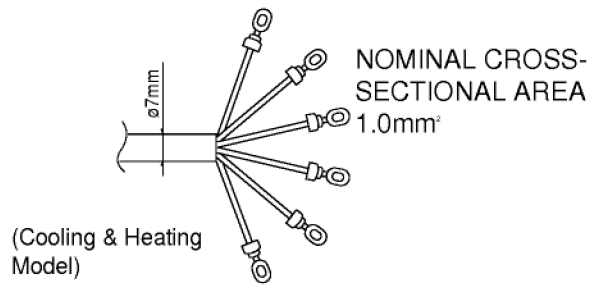

2) Form the pipings

1. Wrap the connecting portion of indoor unit with the Insulation material and secure it with two Plastic Bands(for the right pipings).

- If you want to connect an additional drain hose, the end of the drain-outlet should keep distance from the ground.(Do not dip it into water, and fix it on the wall to avoid swinging in the wind.)

In case of the Outdoor unit is installed bellow position of the Indoor unit.

2. Tape the Pipings, drain hose and Connecting Cable from down to up.

3. Form the pipings gathered by taping along the exterior wall and fix it onto the wall by saddle or equivalent.

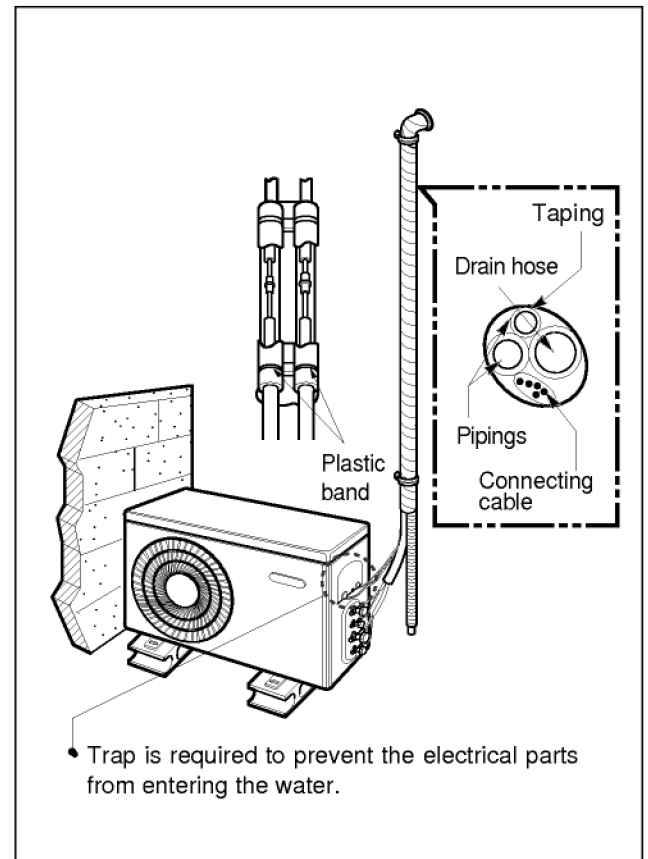

In case of the Outdoor unit is installed upper position of the Indoor unit.

1. Tape the Pipings and Connecting cable from down to up.

2. Form the pipings gathered by taping along the exterior wall and the Trap to be required to prevent the room from entering the water.

3. Fix the pipings onto the wall by saddle or equivalent.

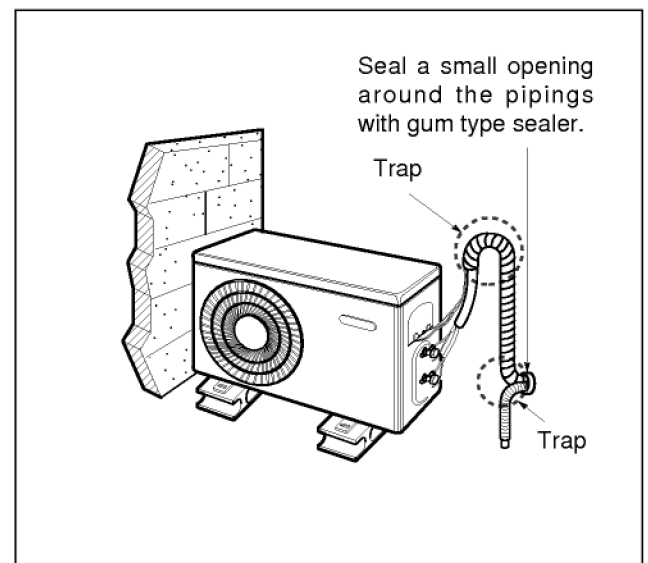

5. Air Purging of the Pipings and indoor unit

1) Air purging

The air which contains moisture remaining in the is refrigeration cycle may cause a malfunction on the compressor.

1. Confirm that both the liquid side valve and the gas side valve are set to the closed position.

2. Connect the charge set and a gas cylinder to the service port of the liquid side valve.

Leave the valve on the gas cylinder closed.

3. Check for gas leakage.

Open the valves on the gas cylinder and the charge set, wait 10 seconds, and then set it to closed position.

Check the flare connections for gas leakage.

4. Air purging

Open the valves on the gas cylinder and the charge set.

Using the Hexagonal wrench to press the gas side valve's core pin, discharge for three seconds and then wait for one minute. Repeat this three times.

5. Discharge the refrigerant.

Close the valve on the gas cylinder and discharge the refrigerant until the gauge indicates 0.5 to 1 kg/cm²-G.

6. Disconnect the charge set and the gas cylinder, and set the liquid side and gas side valves to the open position.

Be sure to use a hexagonal wrench to operate the valve stems.

7. Set the both liquid and gas side valves to open position with the Hexagonal wrench for the unit operation.

Caution

If gas leakage are discovered in step 3 above, take the following measures:

If the gas leaks stop when the piping connections are tightened further, continue working from step 4.

If the gas leaks do not stop when the connections are retightened, repair the location of the leak, discharge all of the gas through the service port, and then recharge with the specified amount of gas from a gas cylinder.

6. Test running

1) Connection of power supply

1. Connect the power supply cord to the independent power supply.

2. Prepare the remote control.

- Insert two batteries provided.
Remove the cover from the back of the remote control.
- Slide the cover according to the arrow direction.
Insert the two batteries.
(Two "R03" or "AAA" dry-cell batteries or equivalent.)
- Be sure that the (+) and (-) directions are correct.
- Be sure that both batteries are new.
Re-attach the cover.
- Slide it back into position.

3. Operate the unit at cooling operation mode for fifteen minutes or more.

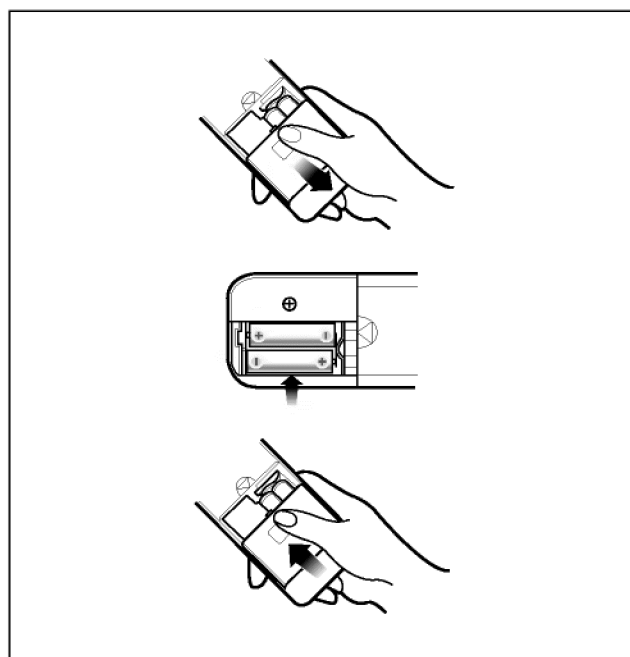

Settlement of Outdoor Unit

- Anchor the outdoor unit with a bolt and nut ($\varnothing 10\text{cm}$) tightly and horizontally on a concrete or rigid mount.
- When installing on the wall, roof or rooftop, anchor the mounting base securely with a nail or wire assuming the influence of wind and earthquake.
- In the case when the vibration of the unit is conveyed to the house, settle the unit with an anti-vibration rubber.

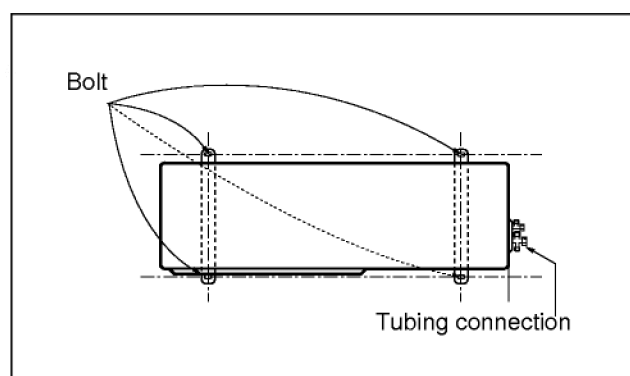

2) Evaluation of the performance

- 1. Measure the temperature of the intake and discharge air.**
- 2. Ensure the difference between the intake temperature and the discharge one is more than 8°C.**

