

This Owner's Manual is provided and hosted by [Appliance Factory Parts](#).

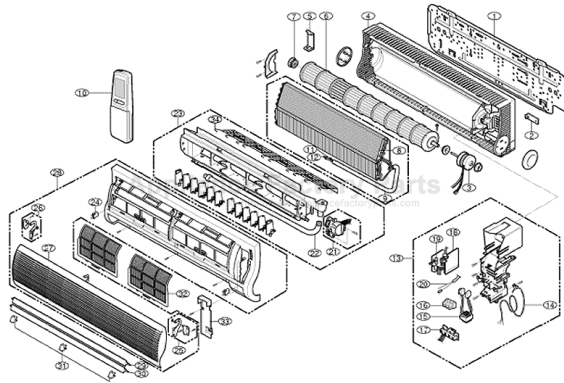

# LG LM-1860CL Owner's Manual

[Shop genuine replacement parts for LG LM-1860CL](#)



[Find Your LG Air Conditioner Parts - Select From 2328 Models](#)

----- Manual continues below -----

# Product Specifications(Cooling)

Item	Model Name	LM-1860CL		
		Unit	INDOOR 1-UNIT	INDOOR 2-UNIT
Cooling Capacity	Btu/h	9,000		9,000 x 2
Moisture Removal	ℓ/h	1.2		2.4
Power Source	∅, V, Hz	1∅, 220-240V~, 50Hz		
Air Circulation	m <sup>3</sup> /min	INDOOR	8.2	8.2 x 2
		OUTDOOR	41	41
Input	W	780		780 x 2
Running Current	A	3.2		3.2 x 2
Motor Output	W	INDOOR	10	10 x 2
		OUTDOOR	48	48
Dimensions(W x H x D)	mm	INDOOR	880 x 302 x 183	
		OUTDOOR	870 x 655 x 320	
Net. Weight	kg	INDOOR	9.5	9.5
		OUTDOOR	55	55
Refrigerant(R-22)	g	780		780 x 2
Airflow Direction Control(Up & Down)		○		○
Remocon Type		L.C.D Wireless		
Service Valve	Liquid	1/4"(6.35)		
	Gas	3/8"(9.52)		
Sleeping Operation		○		○

\* Cooling Capacity Test Temperature : 27°C/19.5°C, 35°C/24°C

# Product Specifications(Cooling & Heating)

Item		Model Name	LM-1860HL		
		Unit	INDOOR 1-UNTI		INDOOR 2-UNTI
Cooling Capacity	BTU/h		9,500		9,500 x 2
Heating Capacity			9,500		9,500 x 2
Moisture Removal	ℓ/h		1.2		2.4
Power Source	ø, V, Hz	1Ø, 220-240V, 50Hz			
Air Circulation	m <sup>3</sup> /min	Indoor	8.2		8.2 x 2
		Outdoor	41		41
Input	Cooling	W	920		920 x 2
	Heating	W	840		840 x 2
Runnig Current	Cooling	A	4.0		4.0 x 2
	Heating	A	3.6		3.6 x 2
E.E.R.	Cooling	BTU/h-w	10.3		10.3
	Heating		11.3		11.3
Motor Output	W	Indoor	10		10 x 2
		Outdoor	48		48
Dimensions(W x H x D)	mm	Indoor	880 x 302 x 183		
		Outdoor	870 x 655 x 320		
Net. Weight	kg	Indoor	9.5		9.5 x 2
		Outdoor	55		55
Refrigerant(R-22)	g	780		780 x 2	
Airflow Direction Control(Up & Down)		O		O	
Remocon Type		L.C.D Wireless			
Service Valve	Liquid	1/4"(6.35)			
	Gas	3/8"(9.52)			
Sleeping Operation		O		O	

\* Cooling Capacity Test Temperature : 27°C/19.5°C, 35°C/24°C

Heating Capacity Test Temperature : 21°C/15.5°C, 7°C/6°C

# Dimensions

## (1) Indoor Unit

### LM-1860CL, LM-1860HL,

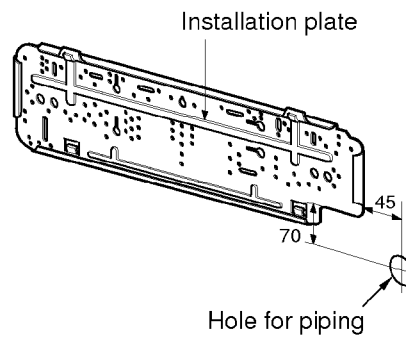
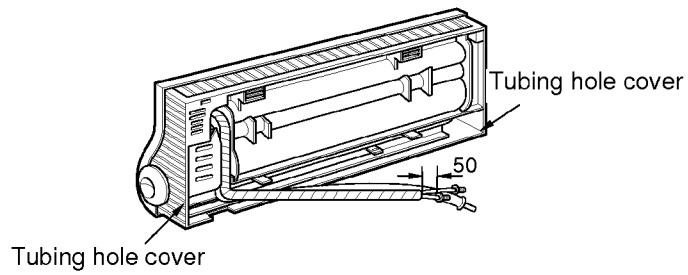
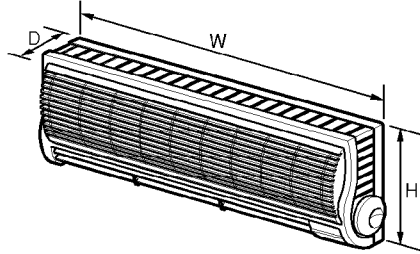

DIM \ MODEL		LM-1860CL, LM-1860HL		
W	mm	880		
H	mm	302		
D	mm	183		

## (2) Outdoor Unit

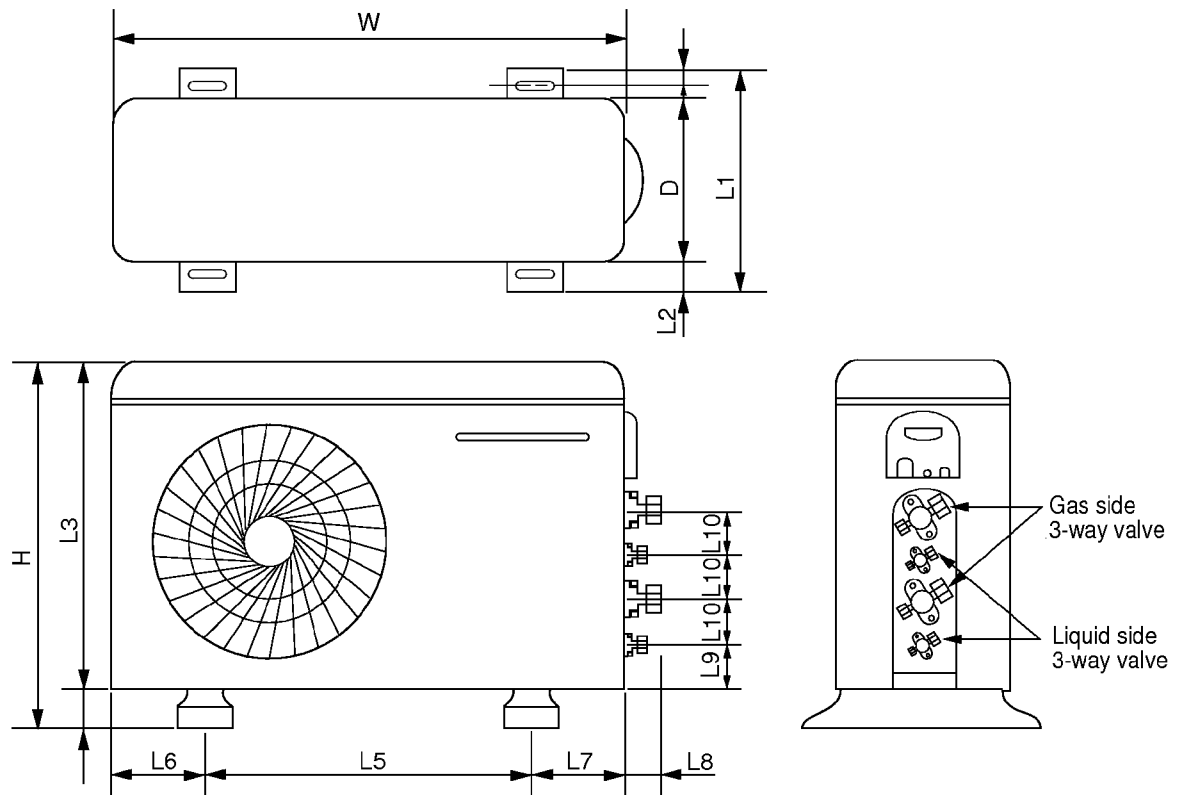

MODEL		LM-1860CL	LM-1860HL		
DIM					
W	mm	870	φB		
H	mm	655	φB		
D	mm	320	φB		
L1	mm	370	φB		
L2	mm	25	φB		
L3	mm	630	φB		
L4	mm	25	φB		
L5	mm	546	φB		
L6	mm	162	φB		
L7	mm	162	φB		
L8	mm	64	φB		
L9	mm	76.5	φB		
L10	mm	50	φB		

# Refrigeration Cycle Diagram

## (1) LM-1860CL

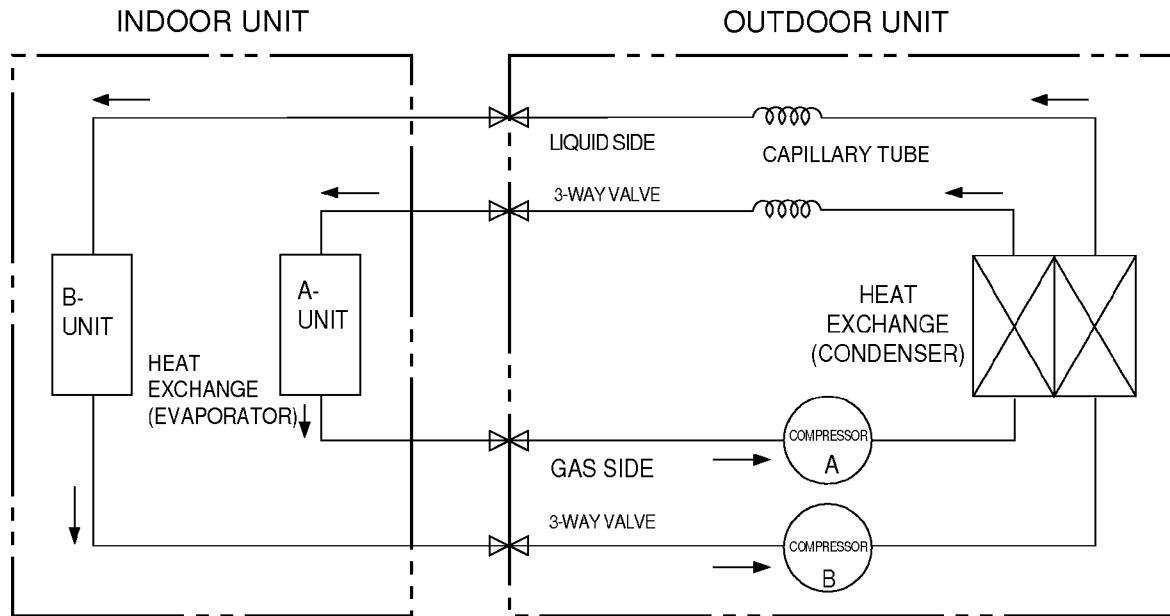

## (2) LM-1860HL

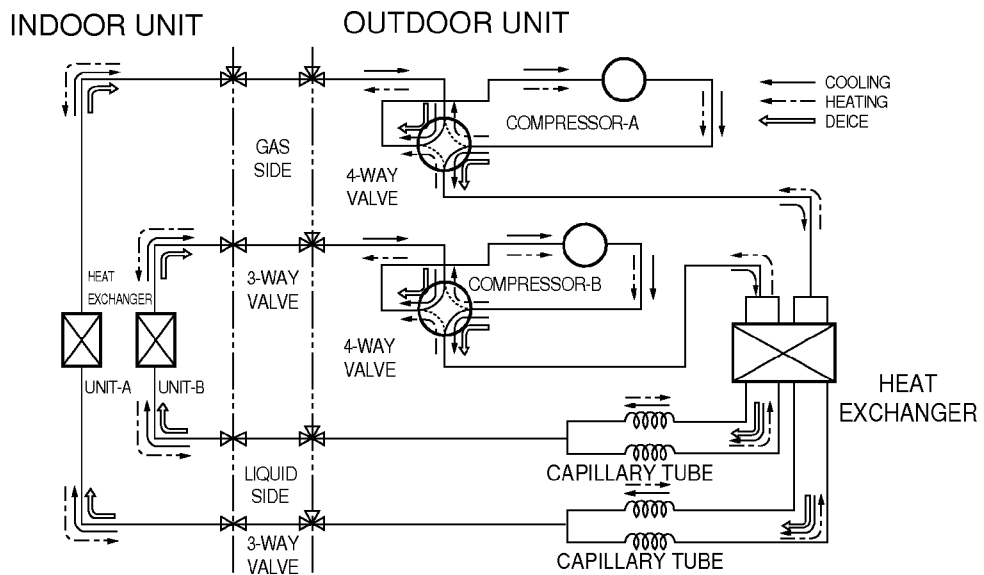

MODEL	Pipe size(Diameter: in)		Max. Piping length A (m)	Max. Elevation B (m)
	Gas	Liquid		
LM-1860CL/ LM-1860HL	3/8"	1/4"	7	5