



website <http://biz.LGservice.com>

e-mail <http://www.LGservice.com/techsup.html>

Room Air Conditioner

SERVICE MANUAL

**MODELS: LWM1860BCG/BCL/QCG/QCL/QAG/BAG
LWN1860BCG/BCL/QCG/QCL
LWN2260BCG/BCL/QCG/QCL
LWM1820BCG/BCL/QCG/QCL
LWM1821BCG/BCL/QCG/QCL
LWN2120BCG/BCL/QCG/QCL
LWN2123BCG
LWM1830BCG/BCL/QCG/QCL
LWN2130BCG/BCL/QCG/QCL,BXN
LWN2131BAG
LWM2130AAG/BAG
LWM1860BCP
LWN2120BHG/BHP/QHG
LWN2123BHG**

CAUTION

- BEFORE SERVICING THE UNIT, READ THE "SAFETY PRECAUTIONS" IN THIS MANUAL.
- ONLY FOR AUTHORIZED SERVICE.

CONTENTS

1. PREFACE

1.1 SAFETY PRECAUTIONS	2
1.2 INSULATION RESISTANCE TEST.....	2
1.3 SPECIFICATIONS	3
1.4 FEATURES	6
1.5 CONTROL LOCATIONS.....	6
1.5.1 COOLING ONLY MODEL	6
1.5.2 HEAT PUMP MODEL	7
1.5.3 COOLING ONLY MODEL WITH REMOTE CONTROL AND TOUCH TYPE.....	8

2. DISASSEMBLY INSTRUCTIONS

2.1 MECHANICAL PARTS.....	10
2.1.1 FRONT GRILLE	10
2.1.2 CABINET.....	10
2.1.3 CONTROL BOX.....	10
2.2 AIR HANDLING PARTS.....	11
2.2.1 COVER (AT THE TOP).....	11
2.2.2 BLOWER.....	11
2.2.3 FAN	11
2.2.4 SHROUD.....	12
2.3 ELECTRICAL PARTS	12
2.3.1 MOTOR.....	12
2.3.2 COMPRESSOR	12
2.3.3 CAPACITOR	13

2.3.4 POWER CORD	13
2.3.5 THERMOSTAT	13
2.3.6 ROTARY SWITCH.....	14
2.3.7 SYNCHRONOUS MOTOR	14
2.4 REFRIGERATION CYCLE.....	15
2.4.1 CONDENSER	15
2.4.2 EVAPORATOR	15
2.4.3 CAPILLARY TUBE.....	15

3. TROUBLESHOOTING GUIDE

3.1 OUTSIDE DIMENSIONS.....	18
3.2 PIPING SYSTEM	18
3.3 TROUBLESHOOTING GUIDE.....	19

4. SCHEMATIC DIAGRAM

4.1 CIRCUIT DIAGRAM.....	29
4.2 ELECTROING CONTROL DEVICE	31
4.3 COMPONENTS LOCATION (OFF MAIN P.C.B ASM).....	32
4.4 COMPONENTS LOCATION (FOR DISPLAY P.C.B ASM).....	33

5. EXPLODED VIEW

6. REPLACEMENT PARTS LIST

1. PREFACE

This SERVICE MANUAL provides various service information, including the mechanical and electrical parts etc. This room air conditioner was manufactured and assembled under a strict quality control system. The refrigerant is charged at the factory. Be sure to read the safety precautions prior to servicing the unit.

1.1 SAFETY PRECAUTIONS

1. When servicing the unit, set the ROTARY SWITCH or POWER SWITCH to OFF and unplug the power cord.
2. Observe the original lead dress.
If a short circuit is found, replace all parts which have been overheated or damaged by the short circuit.
3. After servicing the unit, make an insulation resistance test to protect the customer from being exposed to shock hazards.

1.2 INSULATION RESISTANCE TEST

1. Unplug the power cord and connect a jumper between 2 pins (black and white).
2. The grounding conductor (green or green & yellow) is to be open.
3. Measure the resistance value with an ohm meter between the jumpered lead and each exposed metallic part on the equipment at all the positions (except OFF or O) of the ROTARY SWITCH.
4. The value should be over 1MΩ.

1.3 SPECIFICATIONS

1.3.1 FOR LWM1860BCG(BCL)/LWN1860BCG(BCL)/LWN2260BCG(BCL)/LWM1820BCG(BCL)/LWM1821BCG(BCL) LWN2120BCG(BCL)/LWM1830BCG(BCL)/LWN2130BCG(BCL)/LWN2123BCG/BAG / LWM2130AAG/BAG

MODELS		LWM1860 BCG(BCL) BAG/BCP	LWN1860 BCG (BCL)	LWN2260 BCG (BCL)	LWN1820/1 BCG (BCL)	LWN2120 BCG (BCL)	LWN2123 BCG	LWM2130 AAG/ BAG	LWN1830 BCG (BCL)	LWN2130 BCG(BCL) LWN2131BAG	REMARK
ITEMS											
POWER SUPPLY		1Ø, 220-240V, 50Hz			1Ø, 220V, 60Hz				1Ø, 208-230V, 60Hz		
COOLING CAPACITY		17,500/18,000		21,500/22,000	18,000	21,000	24,000	22,000	18,000	21,000	
INPUT	(W)	2,035/2,100	2,190/2250	2,810/2,890	2,090/2,000	2,440		2,470	2,000	2,470	
RUNNING CURRENT	(A)	9.3/8.6	10.6/10.1	13.5/12.8	9.8/9.0	11.5		10.8	9.0	12	
REFRIGERANT (R-22) CHARGE(g)		690	610	600	630	700		710	740	1,090	
OPERATING TEMPERATURE	INDOOR (°C)	27(DB), 19(WB)							26.55(DB), 19.35(WB)		
	OUTDOOR (°C)	35(DB), 24(WB)							34.85(DB), 23.75(WB)		
EVAPORATOR		2 ROW 15 STACKS			3 ROW 15 STACKS						
CONDENSER		2 ROW 19 STACKS, L-BENDED TYPE								2 ROW 16 STACKS, L-BENDING TYPE	
FAN, INDOOR		BLOWER									
FAN, OUTDOOR		PROPELLER TYPE FAN WITH SLINGER-RING									
FAN SPEEDS, FAN/COOLING		2/3									
FAN MOTOR		6 POLES									
OPERATION CONTROL		ROTARY SWITCH									
ROOM TEMP. CONTROL		THERMOSTAT									
AIR DIRECTION CONTROL		VERTICAL LOUVER(RIGHT & LEFT)									
		HORIZONTAL LOUVER(UP & DOWN)									
CONSTRUCTION		SLIDE IN-OUT CHASSIS									
PROTECTOR	COMPRESSOR	INTERNAL OVERLOAD PROTECTOR									
	FAN MOTOR	INTERNAL THERMAL PROTECTOR									
POWER CORD		1.6m (3 WIRE WITH GROUNDING)									
		CORD-CONNECTED TYPE (ATTACHMENT PLUG: OPTION)									
DRAIN SYSTEM		DRAIN PIPE OR SPLASHED BY FAN SLINGER									
NET WEIGHT	(lbs/kg)	132/60	143/65	148/67	121/55	148/67		121/55	143/65		
OUTSIDE DIMENSION	(inch)	26 x 16 ^{7/32} x 26 ^{9/16}	26 x 16 ^{7/32} x 30 ^{9/16}	26 x 16 ^{7/32} x 26 ^{9/16}	26 x 16 ^{7/32} x 30 ^{9/16}		26 x 16 ^{7/32} x 26 ^{9/16}	26 x 16 ^{7/32} x 30 ^{9/16}			
	(mm)	660 x 428 x 675	660 x 428 x 770	660 x 428 x 675	660 x 428 x 770		660 x 428 x 675	660 x 428 x 770			

**1.3.2 FOR LWM1860QCG(QCL, QAG)/LWN1860QCG(QCL)/LWN2260QCG(QCL)/LWM1820QCG(QCL)
LWM1821QCG(QCL)/LWN2120QCG(QCL)/LWM1830QCG(QCL)/LWN2130QCG(QCL)**

ITEMS		MODELS	LWM1860 QCG (QCL, QAG)	LWN1860 QCG(QCL)	LWN2260 QCG(QCL)	LWM1820/1 QCG(QCL)	LWN2120 QCG(QCL)	LWM1830 QCG(QCL)	LWN2130 QCG(QCL)	REMARK
POWER SUPPLY		1Ø, 220-240V, 50Hz				1Ø, 220V, 60Hz				
COOLING CAPACITY		17,500/18,000		21,500/22,000		18,000	21,000	18,000	21,000	
INPUT (W)		2,035/2,100	2,190/2,250	2,810/2,890	2,090/2,000	2,440	2,000	2,470		
RUNNING CURRENT (A)		9.3/8.6	10.6/10.1	13.5/12.8	9.8/9.0	11.5	9.0	12		
REFRIGERANT (R-22) CHARGE(g)		690	610	600	630	700	740	1,090		
OPERATING TEMPERATURE	INDOOR (°C)	27(DB), 19(WB)					26.55(DB), 19.35(WB)			
	OUTDOOR (°C)	35(DB), 24(WB)					34.85(DB), 23.75(WB)			
EVAPORATOR		2 ROW 15 STACKS			3 ROW 15 STACKS					
CONDENSER		2 ROW 19 STACKS, L-BENDED TYPE							2 ROW 16 STACKS, L-BENDING TYPE	
FAN, INDOOR		BLOWER								
FAN, OUTDOOR		PROPELLER TYPE FAN WITH SLINGER-RING								
FAN SPEEDS, FAN/COOLING		2/2								
FAN MOTOR		6 POLES								
OPERATION CONTROL		WIRELESS REMOCON								
ROOM TEMP. CONTROL		THERMISTOR								
AIR DIRECTION CONTROL		VERTICAL LOUVER(RIGHT & LEFT)								
		HORIZONTAL LOUVER(UP & DOWN)								
CONSTRUCTION		SLIDE IN-OUT CHASSIS								
PROTECTOR	COMPRESSOR	INTERNAL OVERLOAD PROTECTOR								
	FAN MOTOR	INTERNAL THERMAL PROTECTOR								
POWER CORD		1.6m (3 WIRE WITH GROUNDING)								
		CORD-CONNECTED TYPE (ATTACHMENT PLUG: OPTION)								
DRAIN SYSTEM		DRAIN PIPE OR SPLASHED BY FAN SLINGER								
NET WEIGHT (lbs/kg)		132/60	143/65	148/67	121/55	148/67	121/55	143/65		
OUTSIDE DIMENSION (W x H x D)	(inch)	26 x 16 ^{27/32} x 26 ^{9/16}	26 x 16 ^{27/32} x 30 ^{5/16}		26 x 16 ^{27/32} x 26 ^{9/16}	26 x 16 ^{27/32} x 30 ^{5/16}	26 x 16 ^{27/32} x 26 ^{9/16}	26 x 16 ^{27/32} x 30 ^{5/16}		
	(mm)	660 x 428 x 675	660 x 428 x 770		660 x 428 x 675	660 x 428 x 770	660 x 428 x 675	660 x 428 x 770		

1.3.3 FOR LWN2120BHG/BHP/QHG, LWN2123BHG

ITEMS		MODELS		LWN2120BHG/BHP	LWN2120QHG	LWN2123BHG
POWER SUPPLY				1ø, 220V, 60Hz		
COOLING	CAPACITY (BTU/H)		24,000			
	INPUT (W)		2,560			
	RUNNING CURRENT (A)		12.3			
	E.E.R (BTU/W.h)		-			
HEATING	CAPACITY (BTU/h)		24,000			
	INPUT (W)		2,560			
	RUNNING CURRENT (A)		12.3			
	E.E.R (BTU/W.h)		9.4			
OPERATING TEMPERATURE	COOLING	INDOOR (°C)	27 (DB)* 19 (WB)**			
		OUTDOOR (°C)	35 (DB) 24 (WB)			
	HEATING	INDOOR (°C)	20 (DB) 15 (WB)			
		OUTDOOR (°C)	7 (DB) 6 (WB)			
REFRIGERANT (R-22) CHARGE				1200g (42.3 Oz)		
EVAPORATOR				3ROW 15STACKS, LOUVERED-FIN TYPE		
CONDENSER				2ROW 16STACKS, LOUVERED-FIN TYPE		
FAN, INDOOR				TURBO FAN		
FAN, OUTDOOR				PROPELLER TYPE FAN WITH SLINGER-RING		
FAN SPEEDS, FAN/COOLING/HEATING		1/2/2		2/2/2		1/2/2
FAN MOTOR				6 POLES		
OPERATION CONTROL		ROTARY SWITCH		WIRELESS REMOCON		ROTARY SWITCH
ROOM TEMP. CONTROL		THERMOSTAT		THERMISTOR		THERMOSTAT
AIR DIRECTION CONTROL				VERTICAL LOUVER (RIGHT & LEFT)		
				HORIZONTAL LOUVER (UP & DOWN)		
CONSTRUCTION				SLIDE IN-OUT CHASSIS		
PROTECTOR	COMPRESSOR		OVERLOAD PROTECTOR			
	FAN MOTOR		INTERNAL THERMAL PROTECTOR			
POWER CORD				1.8m (7") (3 WIRE WITH GROUDING)		
				ATTACHMENT PLUG (CORD-CONNECTED TYPE)		
DRAIN SYSTEM				DRAIN PAN OR SPLASHED BY FAN SLINGER		
NET WEIGHT (lbs/kg)				147.7(67)		
OUTSIDE DIMENSION (inch)				23 x 16 ²⁷ / ₃₂ x 30 ⁵ / ₁₆		
(W X H X D) (mm)				660 x 428 x 770		

* DB : dry bulb

** WB : wet bulb

1.4 FEATURES

- Designed for cooling only.
- Powerful and quiet cooling.
- Slide-in and slide-out chassis for the simple installation and service.
- Reversible inlet grille.

- Side air-intake, side cooled-air discharge.
- Built in adjustable THERMOSTAT.
- Washable one-touch filter.
- Compact size.

1.5 CONTROL LOCATIONS

1.5.1 COOLING ONLY MODEL

• VENTILATION

The ventilation lever must be in the CLOSE position in order to maintain the best cooling conditions. When a fresh air is necessary in the room, set the ventilation lever to the OPEN position. The damper is opened and room air is exhausted.

NOTE: Before using the ventilation feature, make the lever, as shown. First, pull down part (A) to horizontal line with part (B).

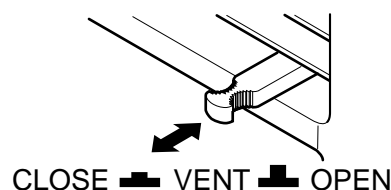
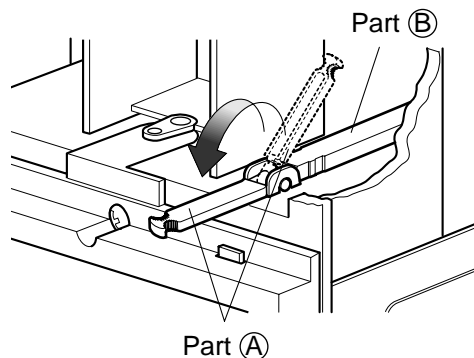

• THERMOSTAT

Thermostat will automatically control the temperature of the room. Select the higher number for the lower temperature of the room. The temperature is selected by positioning the knob to the desired position.

The 5 or 6 position is a normal setting for average conditions.

• OPERATION

- O (0) : Turns the air conditioner off.
- MED FAN (⚙) : Permits the medium fan speed operation without cooling.
- LOW FAN (⚙) : Permits the low fan speed operation without cooling.
- HIGH COOL (✨) : Permits cooling with the high fan speed operation.
- MED COOL (✨) : Permits cooling with the medium fan speed operation.
- LOW COOL (✨) : Permits cooling with the low fan speed operation.

• AUTO SWING

- ON (⚙) : Air swing is operated while OPERATION knob is set to the COOL position.
- OFF (↑) : Stops the operation of air swing.

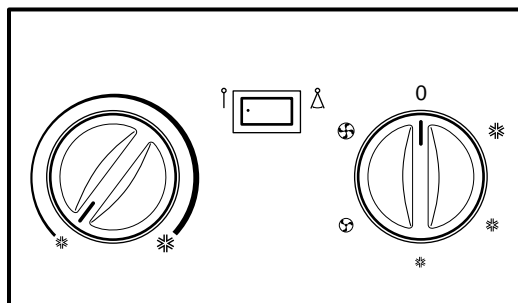
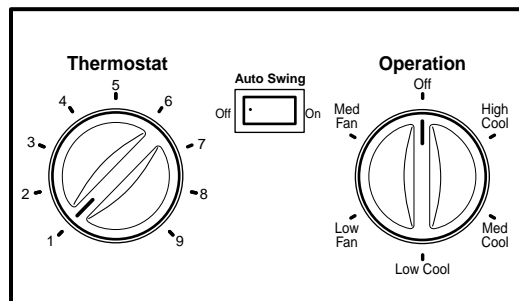

1.5.2 HEAT PUMP MODEL

• CAUTION

When the air conditioner has been performing its cooling operation and is turned off or set to the fan position, wait at least 3 minutes before resetting to the cooling operation again.

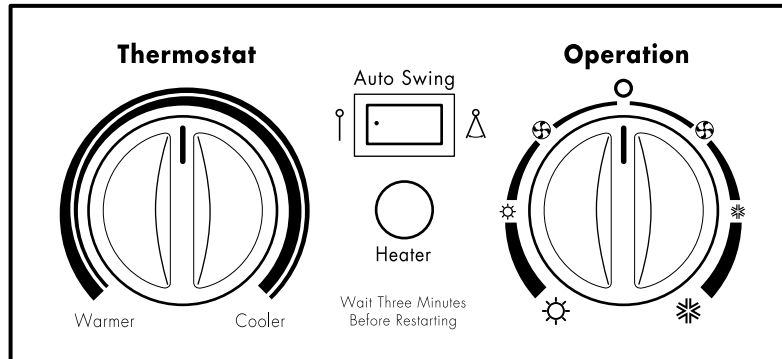

• THERMOSTAT

Turn the thermostat control to the desired setting. The control position is a normal setting for average conditions. You can change this setting, if necessary, in accordance with your temperature preference.

The thermostat automatically controls cooling or heating, but the fan runs continuously whenever the air conditioner is in operation. If the room is too warm, turn the thermostat control clockwise. If the room is too cool, turn the thermostat control counterclockwise.

• HEATER LAMP

When the unit sets heating operation condition, the green lamp is lighted.

When the frost settles on the heat exchanger of the outside, defrosting is made automatically and the green lamp is turned off. The unit may give a hiss and the fan motor stops for 1 to 10 minutes.

This should not be regarded as a problem.

After defrosting, the heating operation begins again.

• OPERATION

- OFF (○) : Turns the air conditioner off.
- LOW FAN (⚙) : Permits the low fan speed operation without cooling (heating).
- LOW COOL (*) : Permits cooling with the low fan speed operation.
- HIGH COOL (*⚙) : Permits cooling with the high fan speed operation.
- LOW HEAT (☀) : Permits heating with the low fan speed operation.
- HIGH HEAT (☀⚙) : Permits heating with the high fan speed operation.

• AUTO SWING

- ON (⚙) : Air swing is operated while OPERATION knob is set to the COOL or HEAT position.
- OFF (↑) : Stops the operation of air swing.

1.5.3 COOLING ONLY MODEL WITH REMOTE CONTROL AND TOUCH TYPE

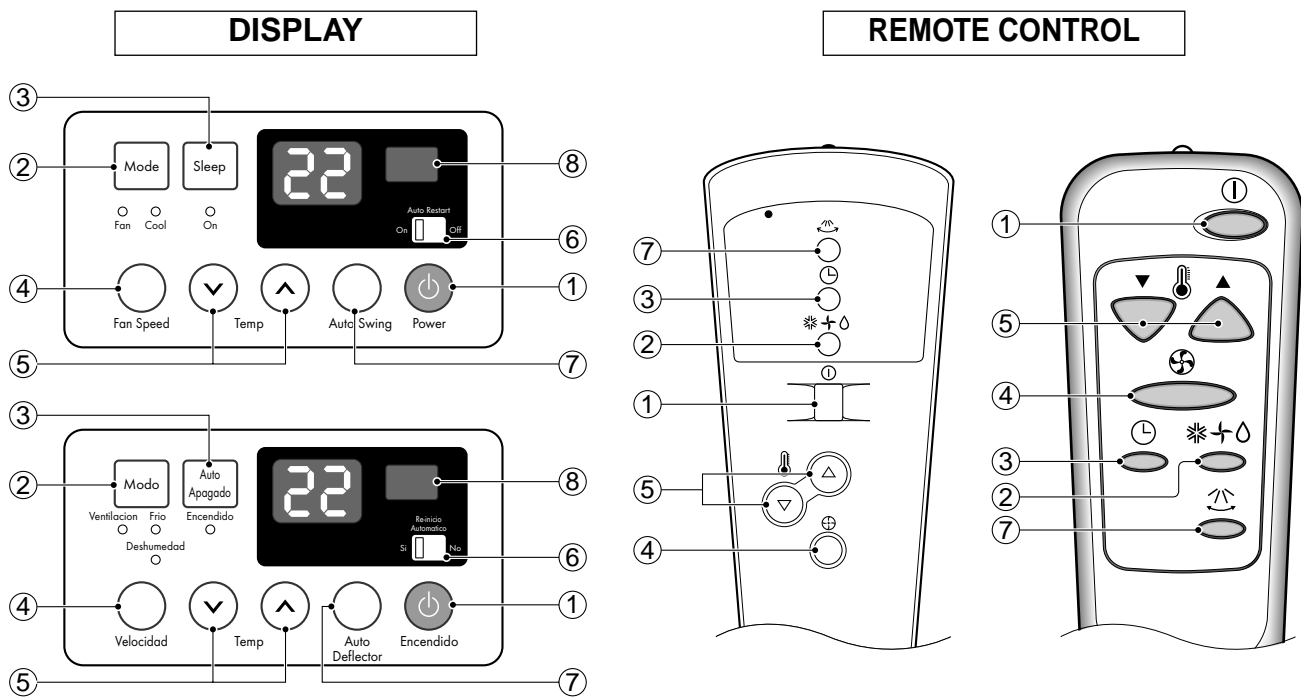

Precaution: The Remote Control unit will not function properly if strong light strikes the sensor window of the air conditioner or if there are obstacles between the Remote Control unit and the air conditioner.

1 POWER BUTTON

Operation starts, when this button is pressed and stops when you press the button again.

2 OPERATION MODE SELECTION BUTTON

Select Cooling, or Fan or Dehumid mode with button. (Dehumid mode is not to all models.)

3 ON/OFF TIMER BUTTON

Set the time of starting and stopping operation. The timer is set by 1 hour.

4 FAN SPEED SELECTOR

Everytime you push this button it is set as follows. [High(F3) → Low(F1) → Med(F2) → High(F3)...].

5 ROOM TEMPERATURE SETTING BUTTON

Control the room temperature within a range of 16°C to 30°C.

6 AUTO RESTART SWITCH (NOT TO ALL MODELS)

In failure of electric power, if the switch is set to "ON", the unit runs as previous setting operation when power returns.

7 AUTO SWING BUTTON

Control the horizontal air direction by air swing system.

8 SIGNAL RECEIVER

DISPLAY

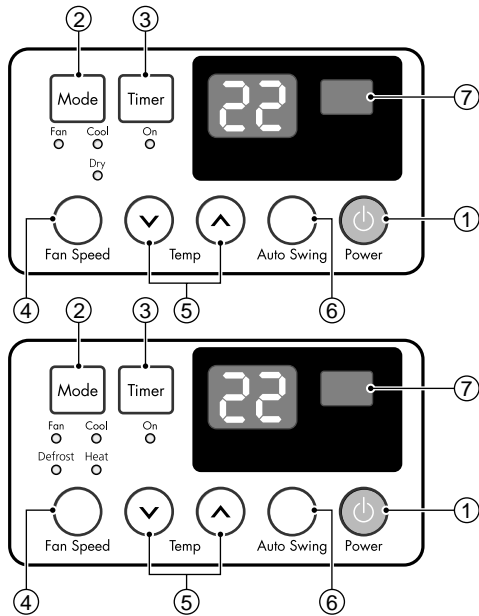

REMOTE CONTROL

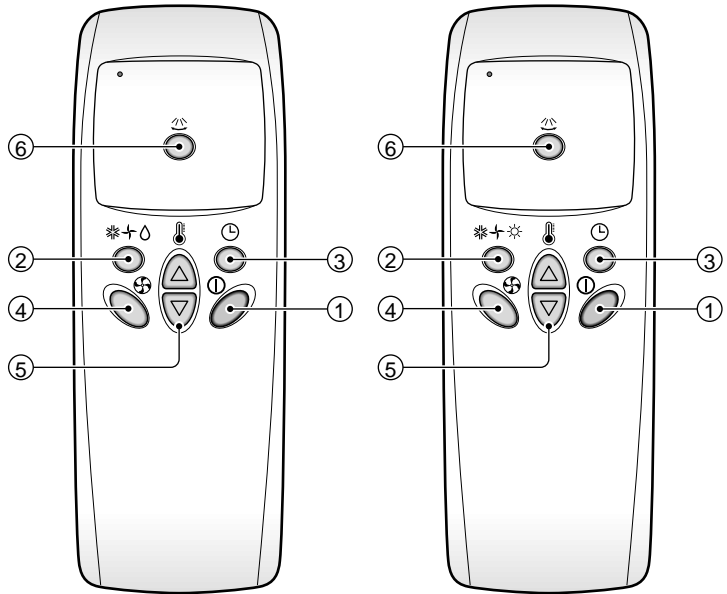

Precaution: The Remote Control unit will not function properly if strong light strikes the sensor window of the air conditioner or if there are obstacles between the Remote Control unit and the air conditioner.

1 POWER BUTTON

Operation starts, when this button is pressed and stops when you press the button again.

2 OPERATION MODE SELECTION BUTTON

Select Cooling, Heating, Fan or Dehumidification(Dry) mode with this button.

3 ON/OFF TIMER BUTTON

Set the time of starting and stopping operation.
The timer is set by 1 hour.

4 FAN SPEED SELECTOR

Select the fan speed

- Cooling Model: High[F3] → Low[F1] → Med[F2] → High[F3]
- Heating Model: High[F2] → Low[F1] → High[F2]

5 ROOM TEMPERATURE SETTING BUTTON

Control the room temperature within a range of 16°C to 30°C.

The unit takes an average of 30 minutes to adjust the room temperature by 1°C (1.8°F).

Temperature increases only by 2°C and no longer increase thereafter.

6 AUTO SWING

The vertical louver swings horizontally by the automatic system and stops when you press the button again.

7 SIGNAL RECEIVER

2. DISASSEMBLY INSTRUCTIONS

— Before the following disassembly, POWER SWITCH is set to OFF and disconnected the power cord.

2.1 MECHANICAL PARTS

2.1.1 FRONT GRILLE

1. Open the inlet grille upward or downward.
2. Remove the screw which fastens the front grille.
3. Pull the front grille from the right side.
4. Remove the front grille. (See Fig. 1)
5. Re-install the component by referring to the removal procedure.

NOTE: Mark "△" of inlet grille means opening direction.

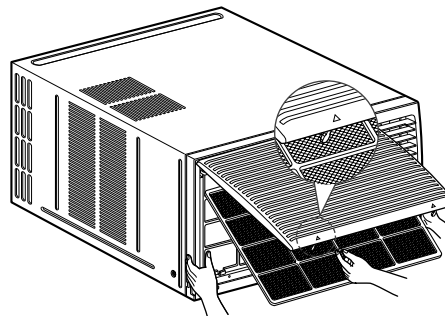

Figure 1

2.1.2 CABINET

1. After disassembling the FRONT GRILLE, remove the screws which fasten the cabinet at both sides.
2. Remove the two screws which fasten the cabinet at back. (See Fig. 2)
3. Pull the base pan forward.

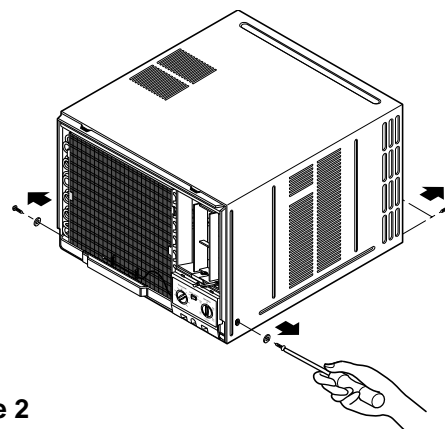

Figure 2

2.1.3 CONTROL BOX

1. Remove the front grille. (Refer to section 2.1.1)
2. Pull the base pan forward so that you can remove the 2 screws which fasten the cover control at the right side. (See Fig. 3)
3. Remove the 3 screws which fasten the control box. (See Fig. 3)
4. Discharge the capacitor by placing a 20,000 ohm resistor across the capacitor terminals.
5. Disconnect two wire housings in the control box.
6. Pull the control box forward completely.
7. Re-install the components by referring to the removal procedure. (See Fig. 3)
(Refer to the circuit diagram found on page 19 in this manual and on the control box.)

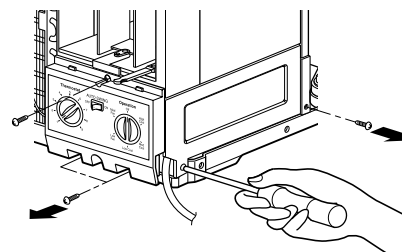

Figure 3

2.2 AIR HANDLING PARTS

2.2.1 COVER (AT THE TOP)

1. Remove the front grille. (Refer to section 2.1.1)
2. Remove the cabinet. (Refer to section 2.1.2)
3. Remove 11 screws which fasten the brace and covers.
4. Remove the covers and the brace. (See Fig. 4)
5. Re-install the components by referring to the removal procedure, above.

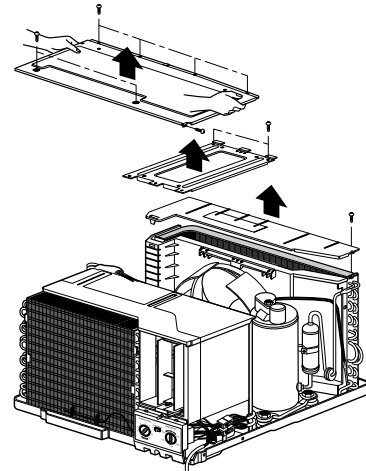

Figure 4

2.2.2 BLOWER

1. Remove the cover. (Refer to section 2.2.1)
2. Remove the 3 screws which fasten the evaporator at the left side and the top side.
3. Move the evaporator sideward carefully.
4. Remove the orifice from the air guide carefully.
5. Remove the clamp which secures the blower with plier. (See Fig. 5)
6. Remove the blower with plier or your hand without touching blades. (See Fig. 6)
7. Re-install the components by referring to the removal procedure, above.

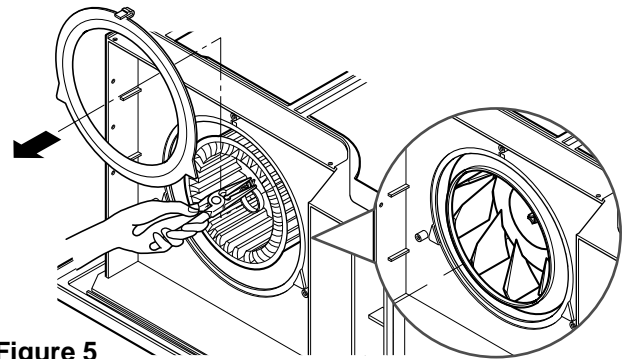

Figure 5

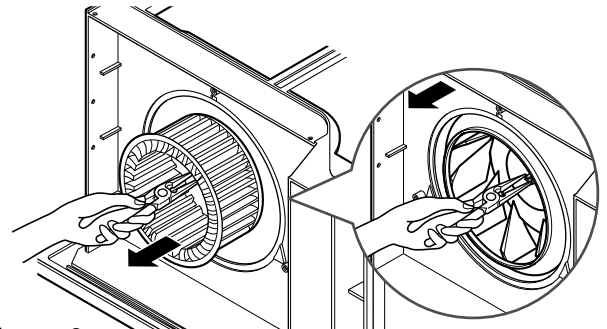

Figure 6

2.2.3 FAN

1. Remove the cabinet. (Refer to section 2.1.2)
2. Remove the brace and shroud cover. (Refer to section 2.2.1)
3. Remove the 5 screws which fasten the condenser.
4. Move the condenser sideways carefully.
5. Remove the clamp which secures the fan.
6. Remove the fan. (See Fig. 7)
7. Re-install the components by referring to the removal procedure, above.

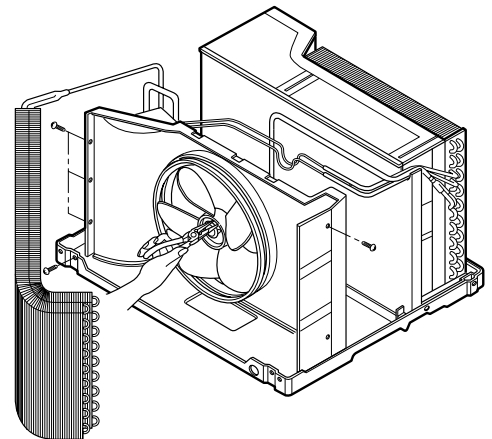

Figure 7

2.2.4 SHROUD

1. Remove the fan. (Refer to section 2.2.3)
2. Remove the 2 screws which fasten the shroud.
3. Remove the shroud. (See Fig. 8)
4. Re-install the component by referring to the removal procedure, above.

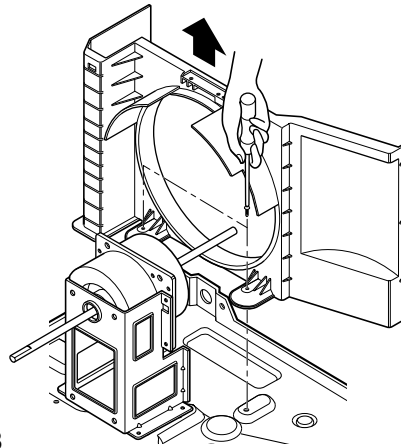

Figure 8

2.3 ELECTRICAL PARTS

2.3.1 MOTOR

1. Remove the cabinet. (Refer to section 2.1.2)
2. Remove the cover control and disconnect a wire housing in control box. (Refer to section 2.1.3)
3. Remove the blower. (Refer to section 2.2.2)
4. Remove the fan. (Refer to section 2.2.3)
5. Remove the 4 screws which fasten the motor. (See Fig. 9)
6. Remove the motor.
7. Re-install the components by referring to the removal procedure, above.

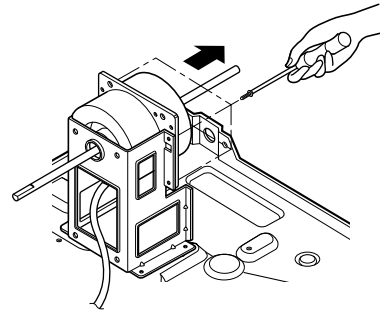

Figure 9

2.3.2 COMPRESSOR

1. Remove the cabinet. (Refer to section 2.1.2)
2. Discharge the refrigerant system using Freon™ Recovery System.
If there is no valve to attach the recovery system, install one (such as a WATCO A-1) before venting the Freon™. Leave the valve in place after servicing the system.
3. Disconnect the 3 leads from the compressor.
4. After purging the unit completely, unbrace the suction and discharge tubes at the compressor connections.
5. Remove the 3 nuts and the 3 washers which fasten the compressor.
6. Remove the compressor. (See Fig. 10)
7. Re-install the components by referring to the removal procedure, above.

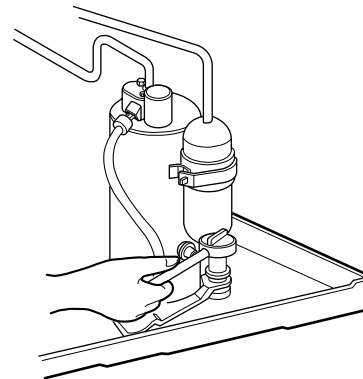

Figure 10

2.3.3 CAPACITOR

1. Remove the control box. (Refer to section 2.1.3)
2. Remove the screw and knobs which fasten the display panel.
3. Disconnect the 2 leads from the rocker switch and remove the panel.
4. Remove a screw and unfold the control box. (See Fig. 11)
5. Remove the screw and the clamp which fastens the capacitor. (See Fig. 11)
6. Disconnect all the leads of capacitor terminals.
7. Re-install the components by referring to the removal procedure, above.

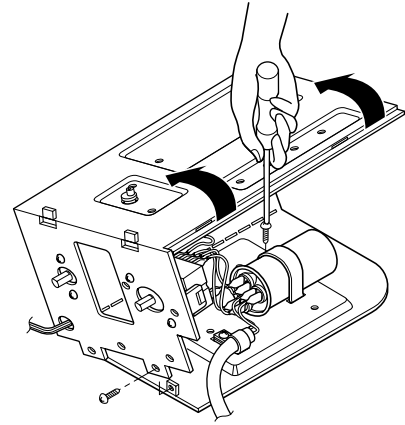

Figure 11

2.3.4 POWER CORD

1. Remove the control box. (Refer to section 2.1.3)
2. Unfold the control box. (Refer to section 2.3.3)
3. Disconnect the grounding screw from the control box.
4. Disconnect 2 receptacles.
5. Remove a screw which fastens the clip cord.
6. Pull the power cord. (See Fig. 12)
7. Re-install the component by referring to the removal procedure, above.
(Use only one ground-marked hole \oplus for ground connection.)
8. If the supply cord of this appliance is damaged, it must be replaced by the special cord.
(The special cord means the cord which has the same specification marked on the supply cord fitted to the unit.)

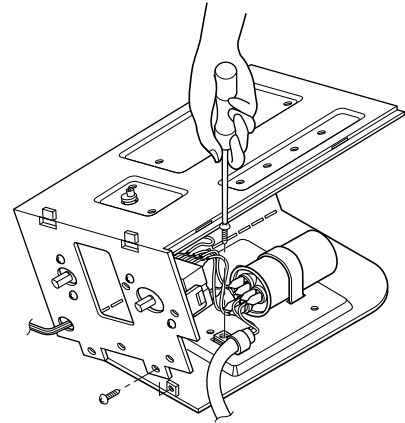

Figure 12

2.3.5 THERMOSTAT

1. Remove the control box. (Refer to section 2.1.3)
2. Unfold the control box. (Refer to section 2.3.3)
3. Remove the 2 screws which fasten the thermostat.
4. Disconnect all the leads of thermostat terminals.
5. Remove the thermostat. (See Fig. 13)
6. Re-install the components by referring to the removal procedure, above.

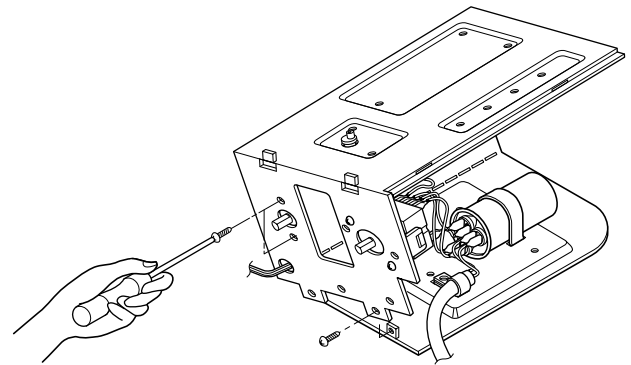

Figure 13

2.3.6 ROTARY SWITCH

1. Remove the control box. (Refer to section 2.1.3)
2. Unfold the control box. (Refer to section 2.3.3)
3. Remove 2 screws which fasten the rotary switch.
4. Disconnect all the leads of the rotary switch terminals.
5. Remove the rotary switch. (See Fig. 14)
6. Re-install the components by referring to the above removal procedure, above.

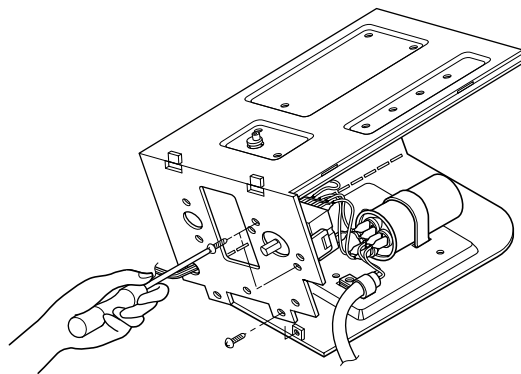

Figure 14

2.3.7 SYNCHRONOUS MOTOR

1. Remove the control box. (Refer to section 2.1.3)
2. Unfold the control box. (Refer to section 2.3.3)
3. Remove the crankshaft.
4. Disconnect all the leads of the synchronous motor.
5. Remove the 2 screws which fasten the synchronous motor. (See Fig. 15)
6. Re-install the components by referring to the removal procedure, above.

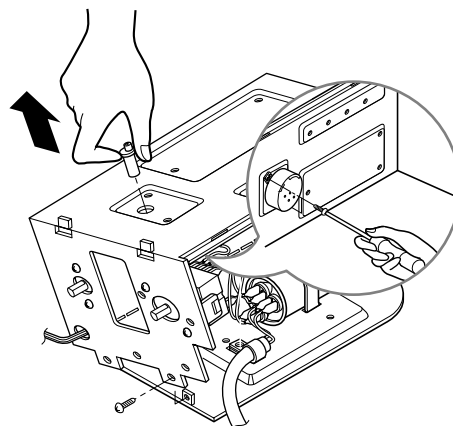

Figure 15

2.4 REFRIGERATION CYCLE

CAUTION

Discharge the refrigerant system using Freon™ Recovery System.

If there is no valve to attach the recovery system, install one (such as a WATCO A-1) before venting the Freon™. Leave the valve in place after servicing the system.

2.4.1 CONDENSER

1. Remove the cabinet. (Refer to section 2.1.2)
2. Remove the brace and the shroud cover. (Refer to section 2.2.1)
3. Remove 6 screws which fasten the condenser.
4. After discharging the refrigerant completely, unbraid the interconnecting tube at the condenser connections.
5. Remove the condenser.
6. Re-install the components by referring to notes. (See Fig. 16)

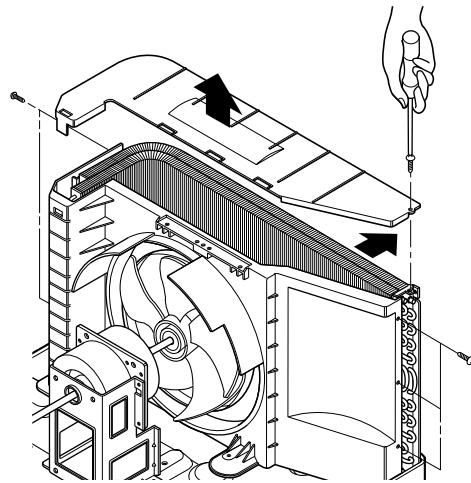

Figure 16

2.4.2 EVAPORATOR

1. Remove the cabinet. (Refer to section 2.1.2)
2. Remove the top cover and the brace. (Refer to section 2.2.1)
3. Discharge the refrigerant completely.
4. Remove the 3 screws which fasten the evaporator at the left side and the top side.
5. Move the evaporator sideward carefully and then unbraid the interconnecting tube at the evaporator connectors.
6. Remove the evaporator.
7. Re-install the components by referring to notes. (See Fig. 17)

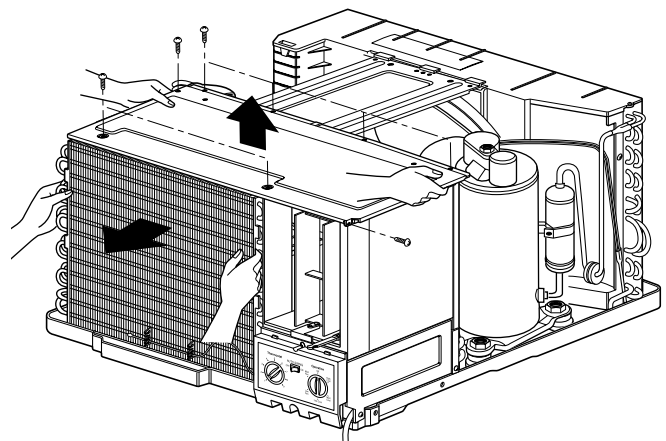

Figure 17

2.4.3 CAPILLARY TUBE

1. Remove the cabinet. (Refer to section 2.1.2)
2. Remove the brace. (Refer to section 2.2.1)
3. After discharging the refrigerant completely, unbraid the interconnecting tube at the capillary tube.
4. Remove the capillary tube.
5. Re-install the components by referring to notes.

NOTES

— Replacement of the refrigeration cycle.

1. When replacing the refrigeration cycle, be sure to discharge the refrigerant system using a Freon™ recovery System.
If there is no valve to attach the recovery system, install one (such as a WATCO A-1) before venting the Freon™. Leave the valve in place after servicing the system.
2. After discharging the unit completely, remove the desired component, and unbrace the pinch-off tubes.
3. Solder service valves into the pinch-off tube ports, leaving the valves open.
4. Solder the pinch-off tubes with Service valves.
5. Evacuate as follows.
 - 1) Connect the vacuum pump, as illustrated Fig. 18A.
 - 2) Start the vacuum pump, slowly open manifold valves A and B with two full turns counterclockwise and leave the valves closed. The vacuum pump is now pulling through valves A and B up to valve C by means of the manifold and entire system.

CAUTION

If high vacuum equipment is used, just crack valves A and B for a few minutes, then open slowly with the two full turns counterclockwise. This will keep oil from foaming and being drawn into the vacuum pump.

- 3) Operate the vacuum pump for 20 to 30 minutes, until 600 microns of vacuum is obtained. Close valves A and B, and observe vacuum gauge for a few minutes. A rise in pressure would indicate a possible leak or moisture remaining in the system. With valves A and B closed, stop the vacuum pump.
- 4) Remove the hose from the vacuum pump and place it on the charging cylinder. See Fig. 19B. Open valve C.
Discharge the line at the manifold connection.
- 5) The system is now ready for final charging.

6. Recharge as follows :

- 1) Refrigeration cycle systems are charged from the High-side. If the total charge cannot be put in the High-side, the balance will be put in the suction line through the access valve which you installed as the system was opened.
- 2) Connect the charging cylinder as shown in Fig. 18B. With valve C open, discharge the hose at the manifold connection.
- 3) Open valve A and allow the proper charge to enter the system. Valve B is still closed.
- 4) If more charge is required, the high-side will not take it. Close valve A.
- 5) With the unit running, open valve B and add the balance of the charge.
 - a. Do not add the liquid refrigerant to the Low-side.
 - b. Watch the Low-side gauge; allow pressure to rise to 30 lbs.
 - c. Turn off valve B and allow pressure to drop.
 - d. Repeat steps B and C until the balance of the charge is in the system.
- 6) When satisfied the unit is operating correctly, use the pinch-off tool with the unit still running and clamp on to the pinch-off tube. Using a tube cutter, cut the pinch-off tube about 2 inches from the pinch-off tool. Use sil-fos solder and solder pinch-off tube closed. Turn off the unit, allow it to set for a while, and then test the leakage of the pinch-off connection.

Equipment needed: Vacuum pump, Charging cylinder, Manifold gauge, Brazing equipment. Pinch-off tool capable of making a vapor-proof seal, Leak detector, Tubing cutter, Hand Tools to remove components, Service valve.

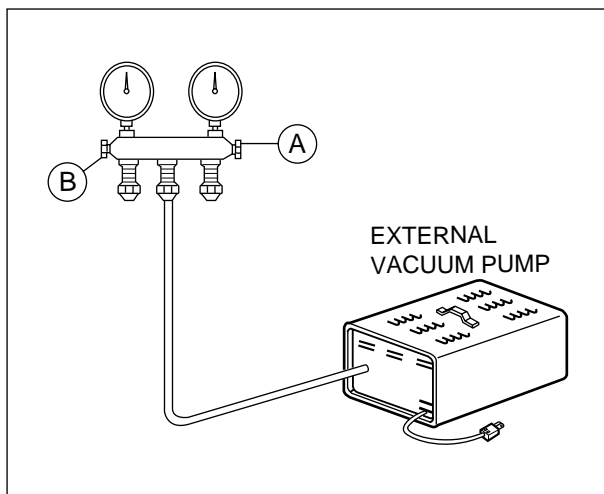
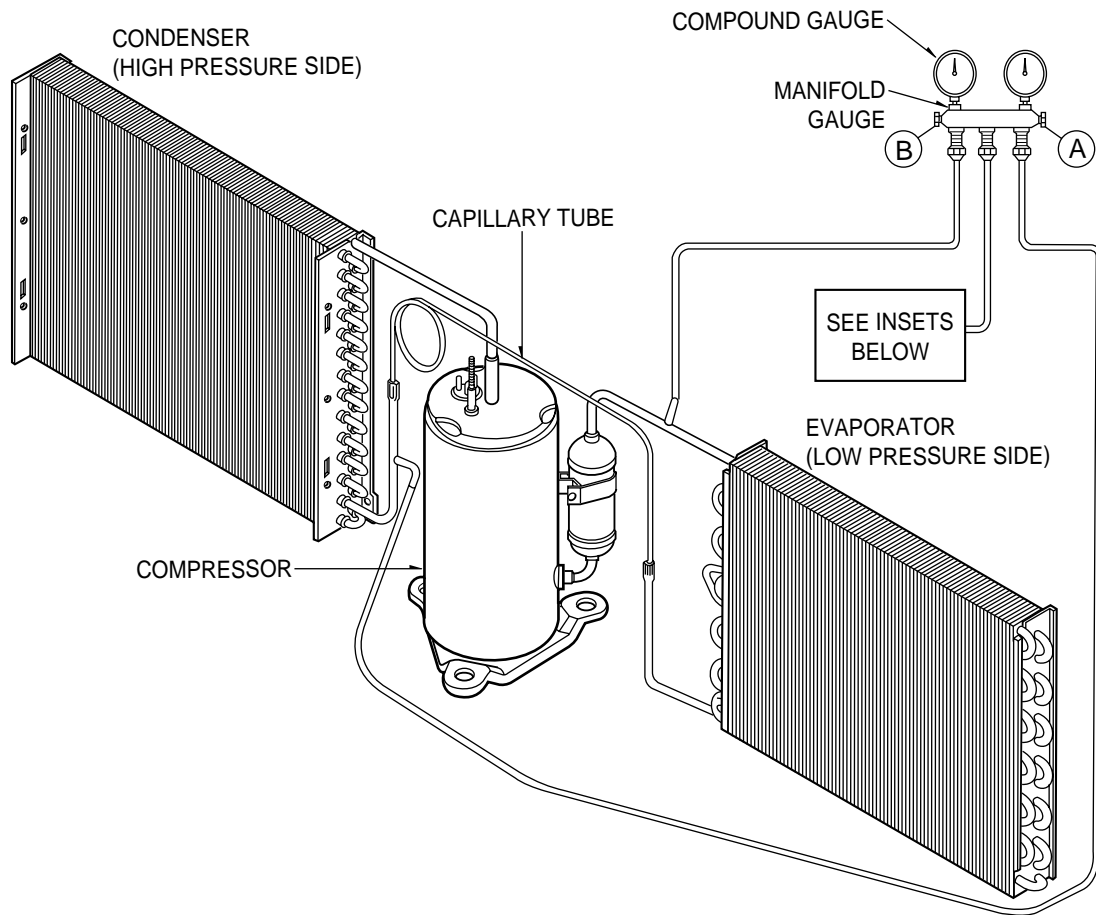

Figure 18A-Pulling Vacuum

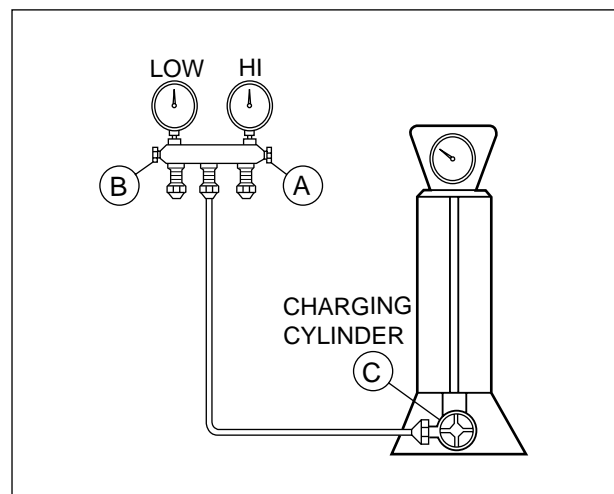
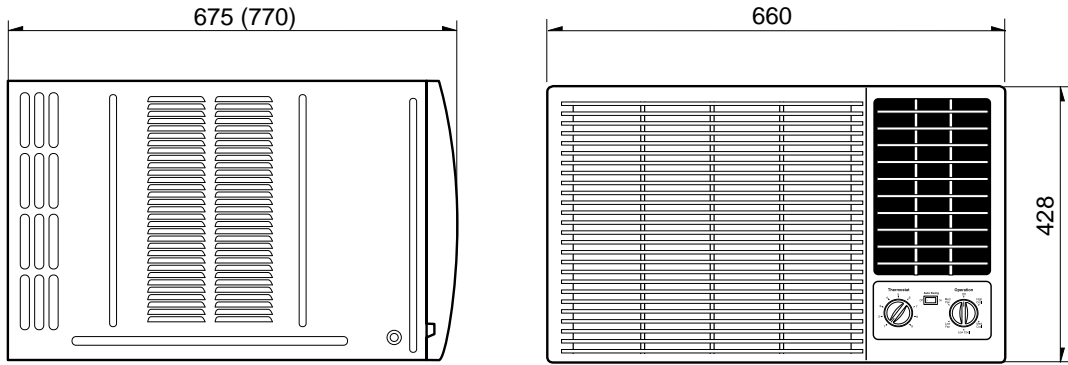

Figure 18B-Charging

3. TROUBLESHOOTING GUIDE

3.1 OUTSIDE DIMENSIONS



3.2 PIPING SYSTEM

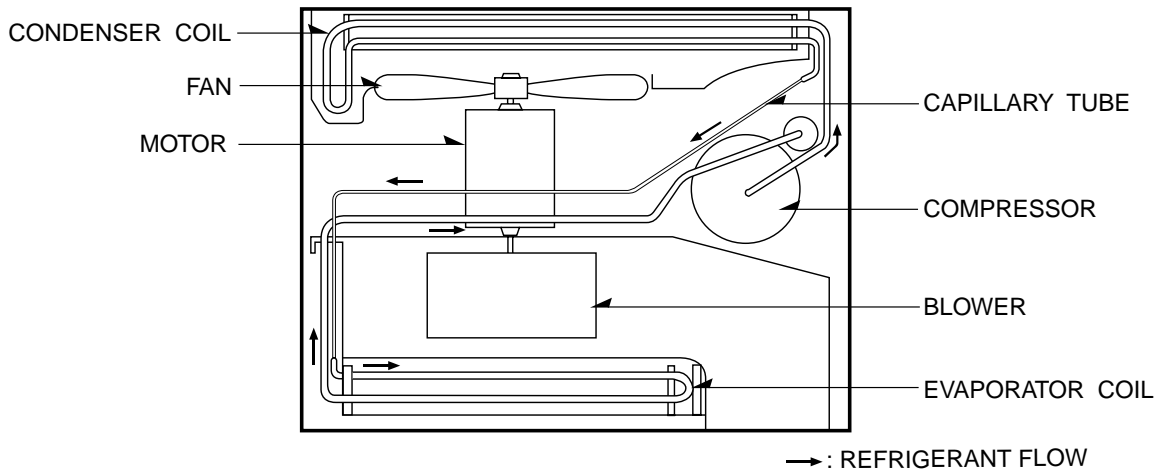

Following is a brief description of the important components and their functions in the refrigeration system. Refer to Fig. 19 to follow the refrigeration cycle and the flow of the refrigerant in the cooling cycle.

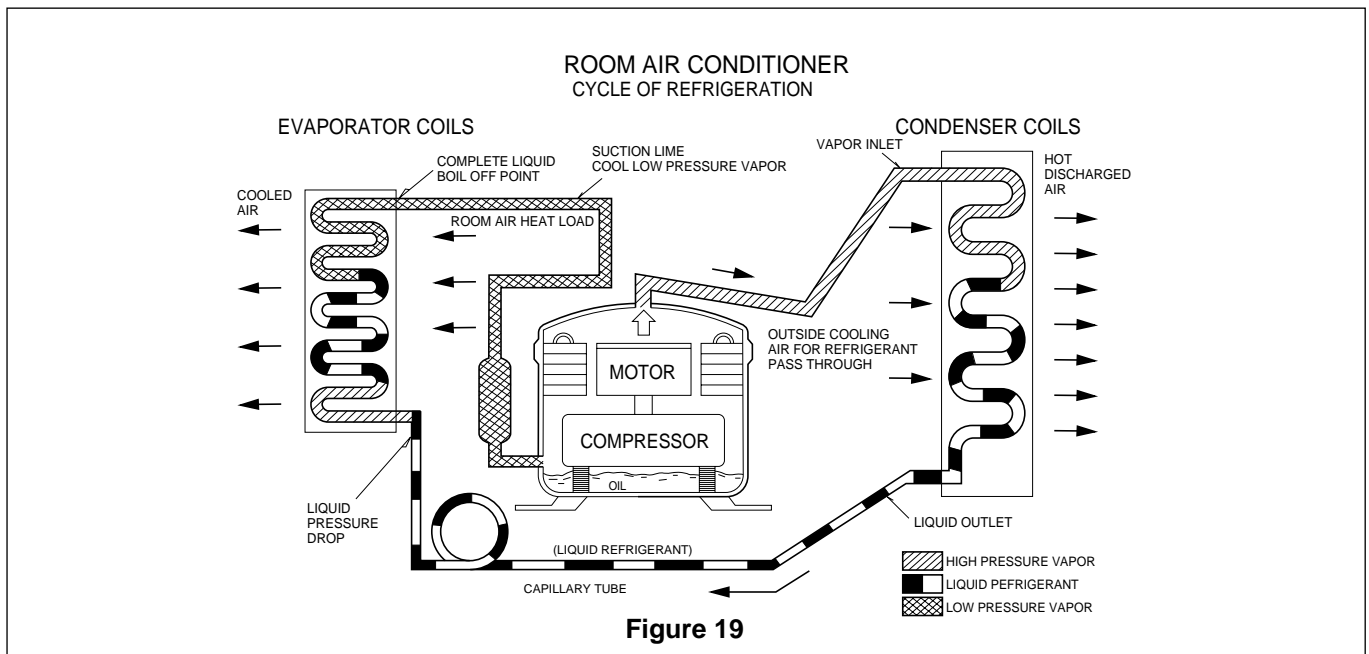

3.3 TROUBLESHOOTING GUIDE

In general, possible trouble is classified in two causes.

The one is called Starting Failure which is caused from an electrical defect, and the other is Ineffective Air Conditioning caused by a defect in the refrigeration circuit and improper application.

Unit runs but poor cooling

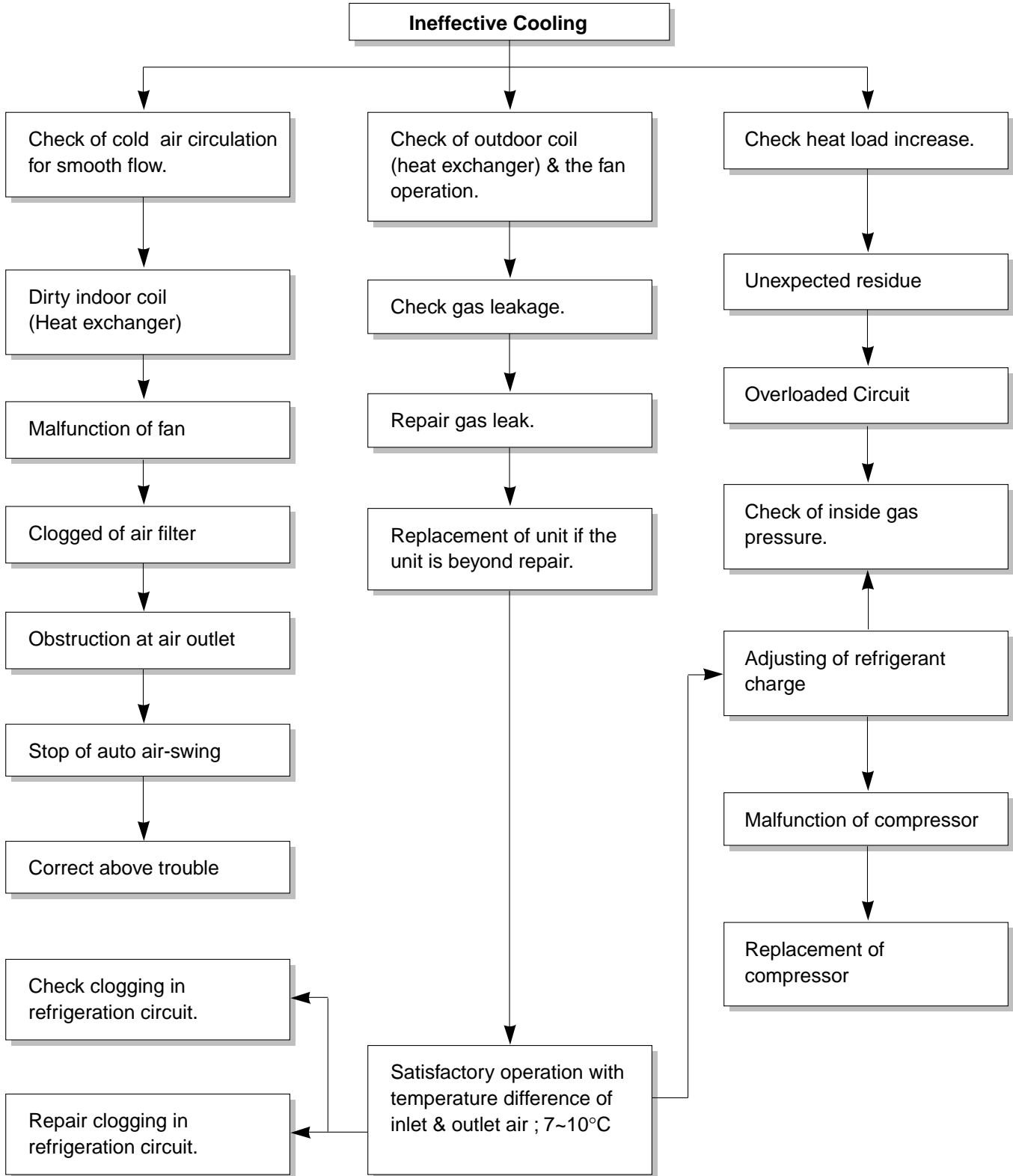

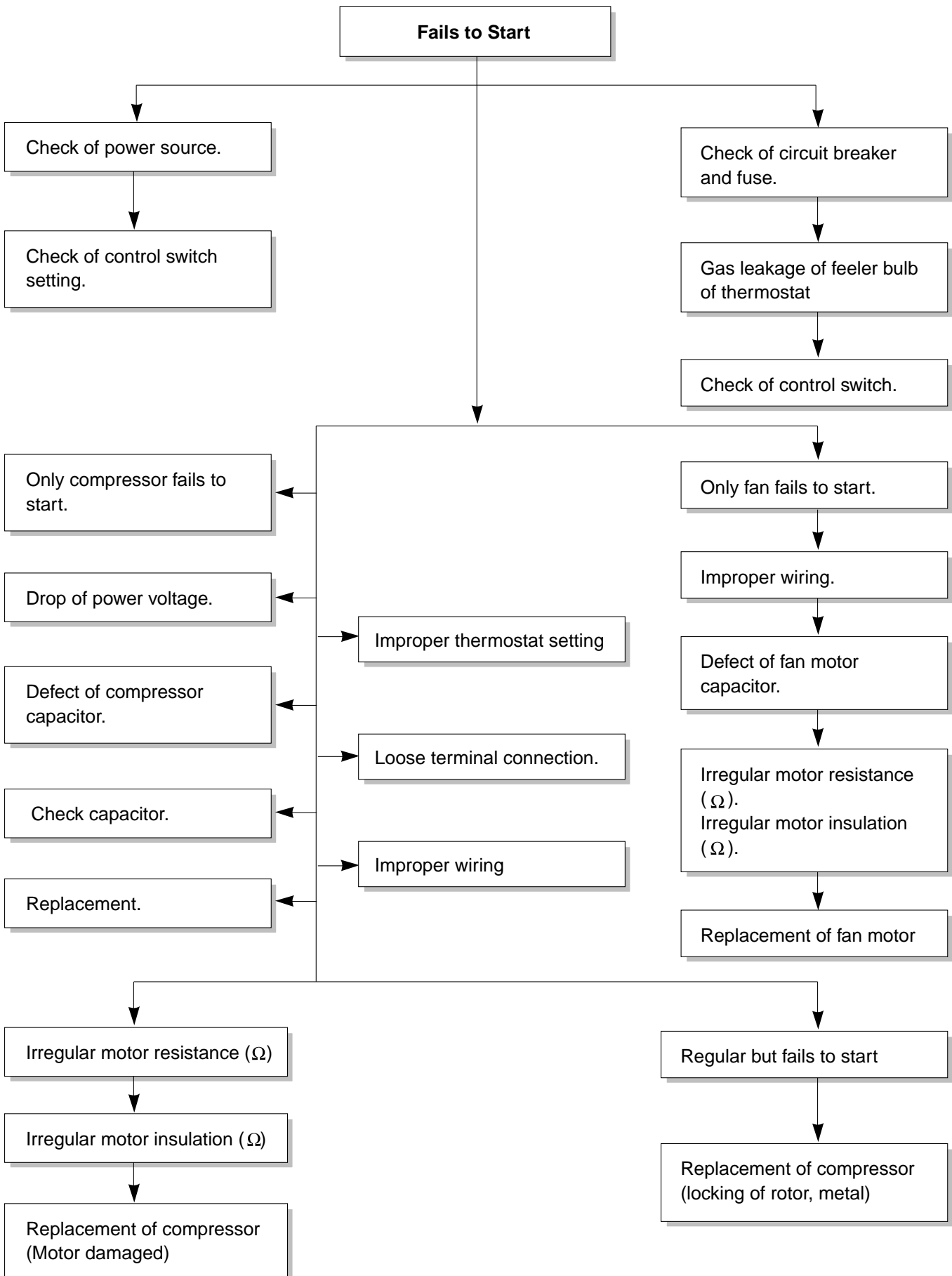

Electrical Parts Troubleshooting Guide : Micom Models

Possible Trouble 1 The unit does not operate.

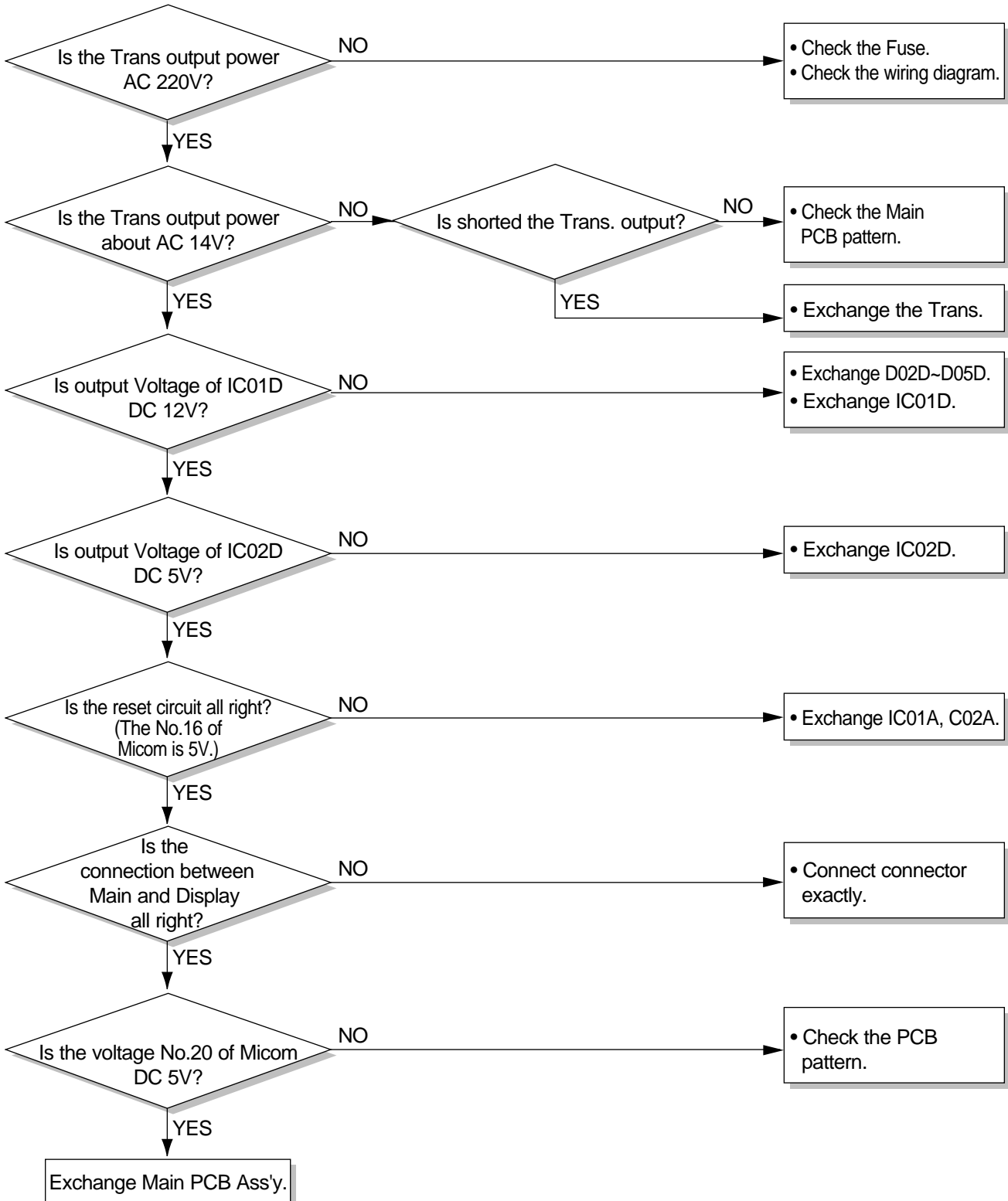

Possible Trouble 2 The compressor does not operate.

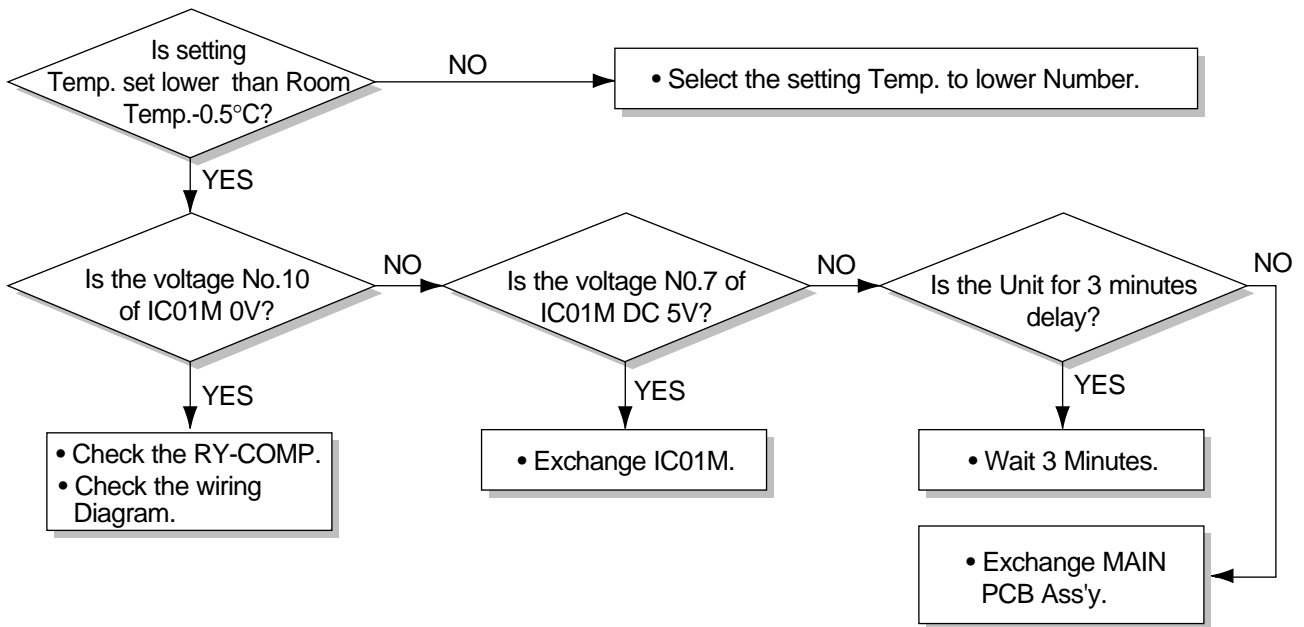

Possible Trouble 3 The compressor always operate.



Possible Trouble 4 FAN does not operate.

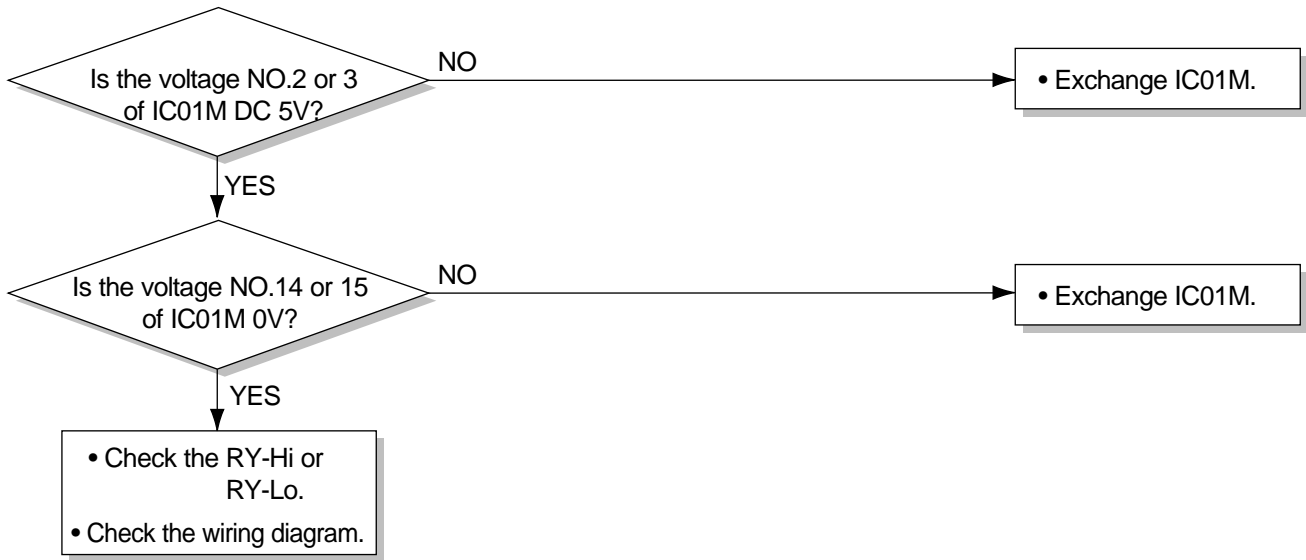

Possible Trouble 5 Auto Swing does not operate.

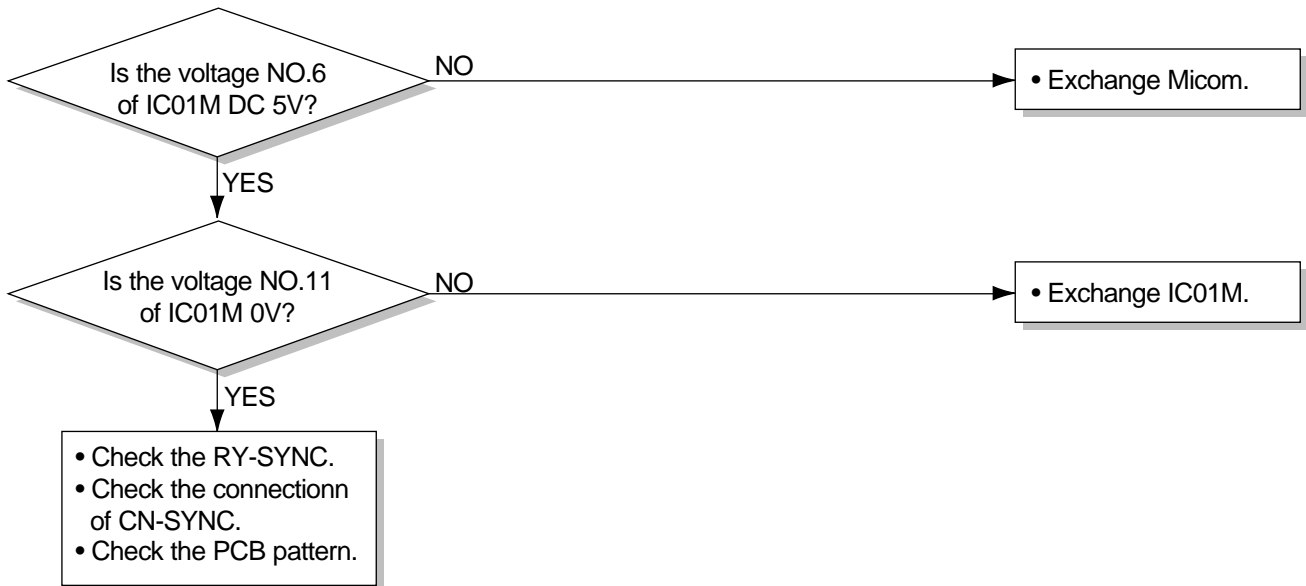

Possible Trouble 6 Remote controller does not operate.

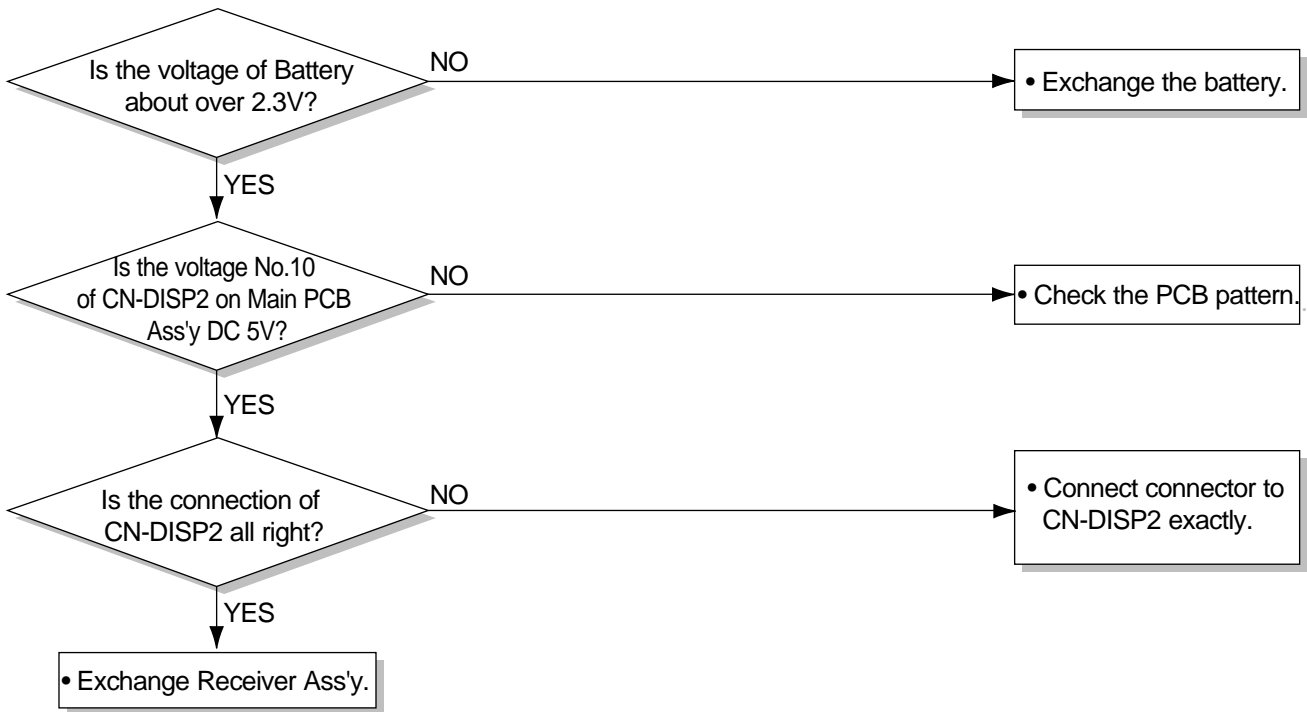

Possible Trouble 7 It displays abnormally on display PCB Ass'y.

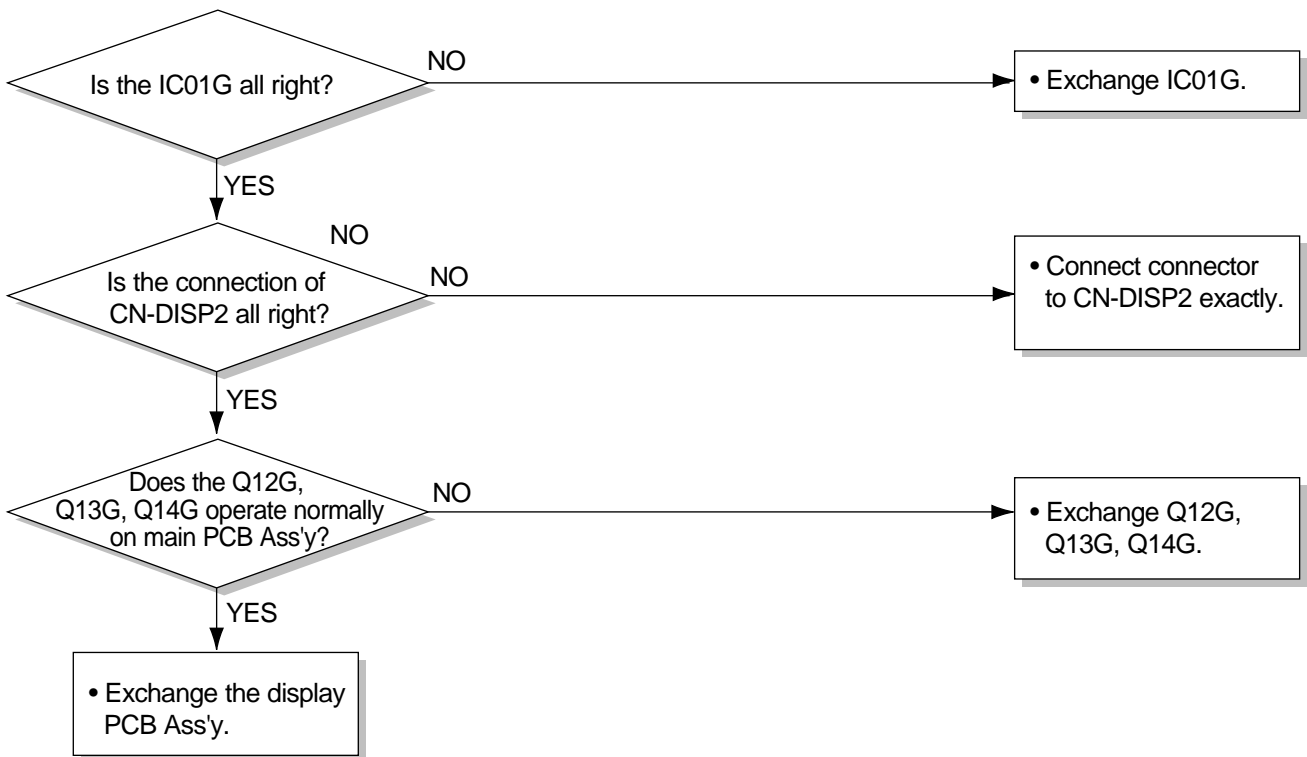

Possible Trouble 8

The function of Auto Restart does not operate.

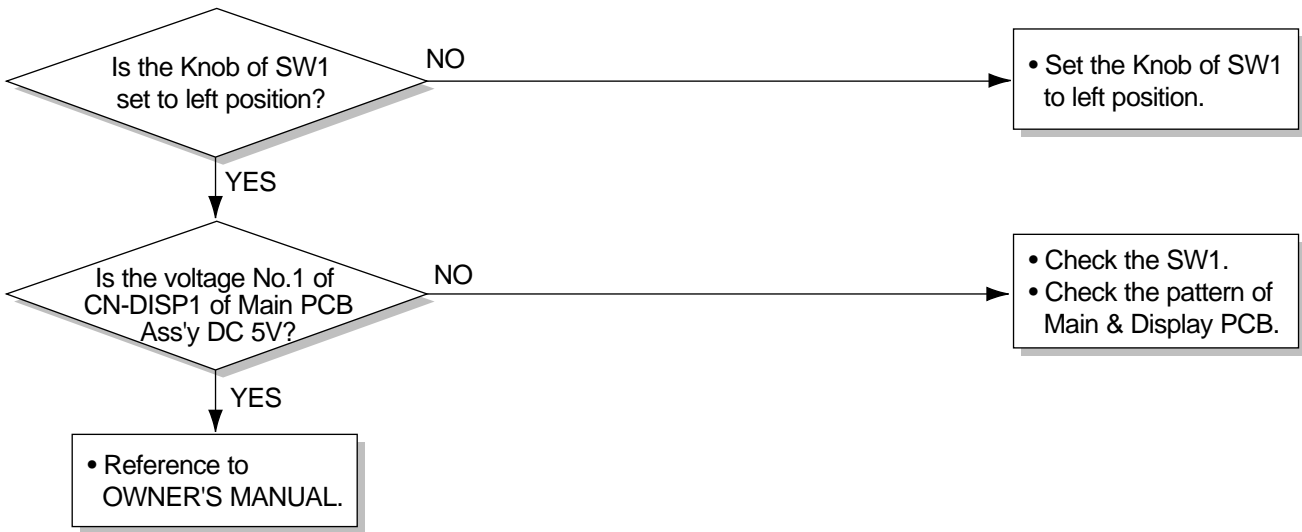

COMPLAINT	CAUSE	REMEDY
Fan motor will not run.	No power	Check voltage at outlet. Correct if none.
	Power supply cord	Check voltage to rotary switch. If none, check power supply cord. Replace cord if circuit is open.
	Rotary switch	Check switch continuity. Refer to wiring diagram for terminal identification. Replace switch if defective.
	Wire disconnected or connection loose	Connect wire. Refer to wiring diagram for terminal identification. Repair or replace loose terminal.
	Capacitor (Discharge capacitor before testing.)	Test capacitor. Replace if not within $\pm 10\%$ of manufacturer's rating. Replace if shorted, open, or damaged.
	Will not rotate	<p>Fan blade hitting shroud or blower wheel hitting scroll. Realign assembly.</p> <p>Units using slinger ring condenser fans must have $\frac{1}{4}$ to $\frac{5}{16}$ inch clearance to the base. If it is hitting the base, shim up the bottom of the fan motor with mounting screw(s).</p> <p>Check fan motor bearings; if motor shaft will not rotate, replace the motor.</p>
Fan motor runs intermittently	Revolves on overload.	<p>Check voltage. See limits on this page. If not within limits, call an electrician.</p> <p>Test capacitor. Check bearings. Does the fan blade rotate freely? If not, replace fan motor.</p> <p>Pay attention to any change from high speed to low speed. If the speed does not change, replace the motor.</p>
Fan motor noise.	Grommets	Check grommets; if worn or missing, replace them.
	Fan	If cracked, out of balance, or partially missing, replace it.
	Blower	If cracked, out of balance, or partially missing, replace it.
	Loose set screw	Tighten it.
	Worn bearings	If knocking sounds continue when running or loose, replace the motor. If the motor hums or noise appears to be internal while running, replace motor.

COMPLAINT	CAUSE	REMEDY
Compressor will not run, but fan motor runs.	Voltage	Check voltage. See the limits on the preceding page. If not within limits, call an electrician.
	Wiring	Check the wire connections, if loose, repair or replace the terminal. If wires are off, refer to wiring diagram for identification, and replace. Check wire locations. If not per wiring diagram, correct.
	Rotary	Check for continuity, refer to the wiring diagram for terminal identification. Replace the switch if circuit is open.
	Thermostat	Check the position of knob. If not at the coldest setting, advance the knob to this setting and restart unit. Check continuity of the thermostat. Replace thermostat if circuit is open.
	Capacitor (Discharge capacitor before servicing.)	Check the capacitor. Replace if not within $\pm 10\%$ of manufacturer's rating. Replace if shorted, open, or damaged.
	Compressor	Check the compressor for open circuit or ground. If open or grounded, replace the compressor.
	Overload	Check the compressor overload, if externally mounted. Replace if open. (If the compressor temperature is high, remove the overload, cool it, and retest.)
Compressor cycles on overload.	Voltage	Check the voltage. See the limits on the preceding page. If not within limits, call an electrician.
	Overload	Check overload, if externally mounted. Replace if open. (If the compressor temperature is high, remove the overload, cool, and retest.)
	Fan motor	If not running, determine the cause. Replace if required.
	Condenser air flow restriction	Remove the cabinet. inspect the interior surface of the condenser; if restricted, clean carefully with a vacuum cleaner (do not damage fins) or brush. Clean the interior base before reassembling.
	Condenser fins (damaged)	If condenser fins are closed over a large area on the coil surface, head pressures will increase, causing the compressor to cycle. Straighten the fins or replace the coil.

COMPLAINT	CAUSE	REMEDY
Compressor cycles on overload.	Capacitor	Test capacitor.
	Wiring	Check the terminals. If loose, repair or replace.
	Refrigerating system	Check the system for a restriction.
Insufficient cooling or heating	Air filter	If restricted, clean or replace.
	Exhaust damper door	Close if open.
	Unit undersized	Determine if the unit is properly sized for the area to be cooled.
Excessive noise.	Blower or fan	Check the set screw or clamp. If loose or missing, correct. If the blower or fan is hitting air guide, rearrange the air handling parts.
	Copper tubing	Remove the cabinet and carefully rearrange tubing not to contact cabinet, compressor, shroud, and barrier.
Auto air-swing fails.	Rotary switch.	Set the knob to HIGH COOL or LOW COOL while rocker switch is ON.
	Wiring	Check terminals. If loose, repair or replace.
	Synchronous motor.	Check the synchronous motor for open circuit.

4. SCHEMATIC DIAGRAM

4.1 CIRCUIT DIAGRAM

- MODEL : LWN1860BCG(BCL, BCP, BAG)/LWN2260BCG(BCL)/LWM1860BCG(BCL)/LWM1820BCG(BCL)
LWM1821BCG(BCL)/LWN2120BCG(BCL)/LWM1830BCG(BCL)/LWN2130BCG(BCL)
LWN2131BAG/LWM2130AAG/BAG

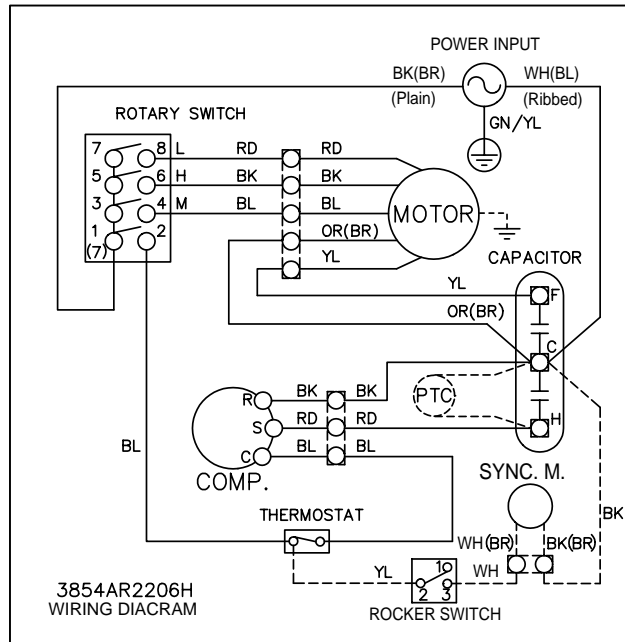

- MODEL : LWN2123BCG

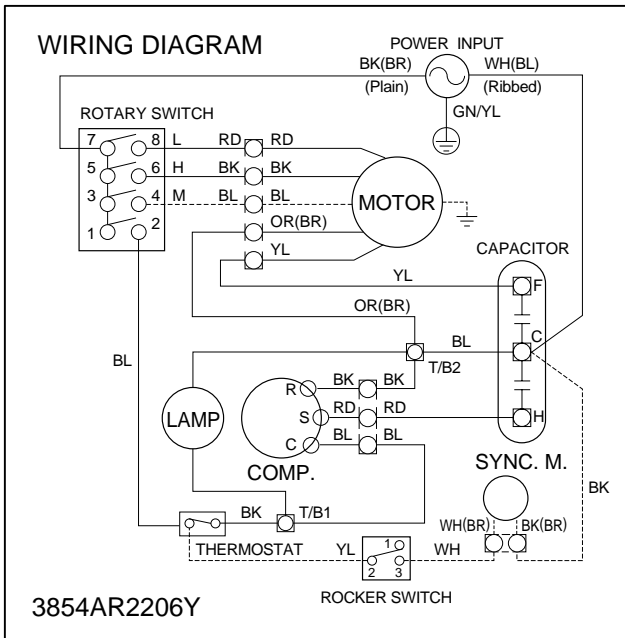

- MODEL : LWN2120BHG/BHP
LWN2123BHG

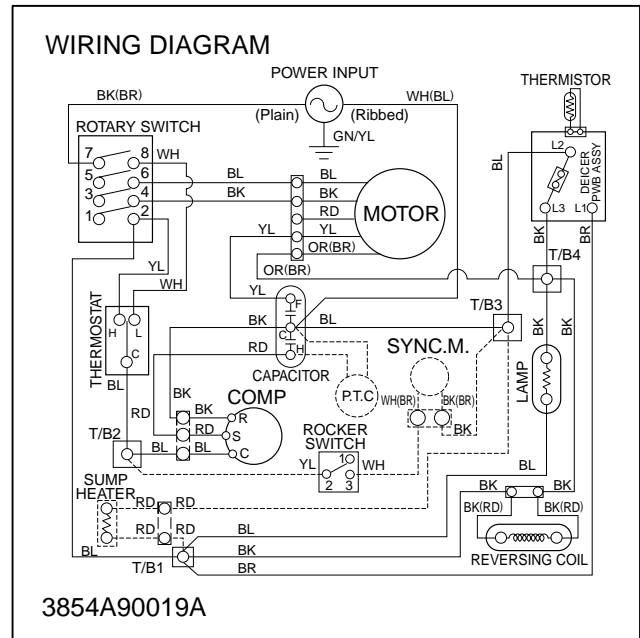

- MODEL : LWM1860QCG(QCL)/LWN1860QCG(QCL)/LWN2260QCG(QCL)/LWM1820QCG(QCL)
LWM1821QCG(QCL)/LWN2120QCG(QCL)/LWM1830QCG(QCL)/LWN2130QCG(QCL)

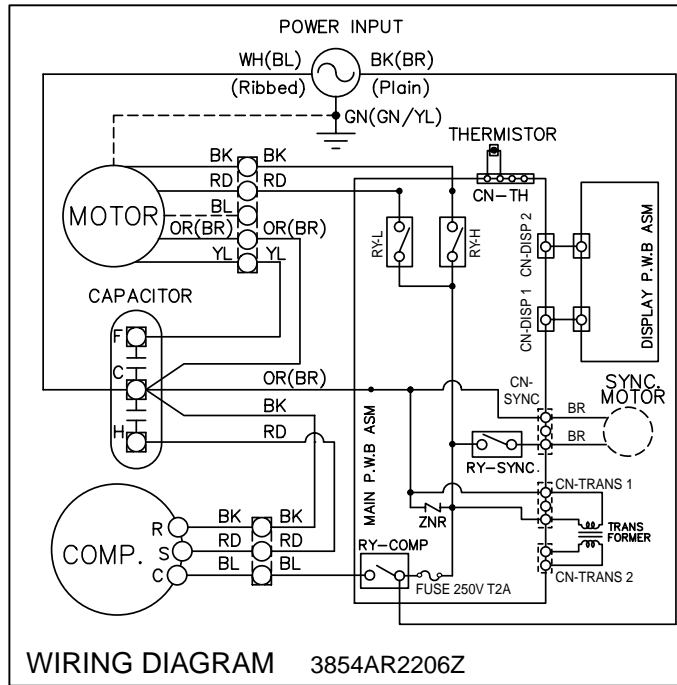

- MODEL : LWM1860QAG

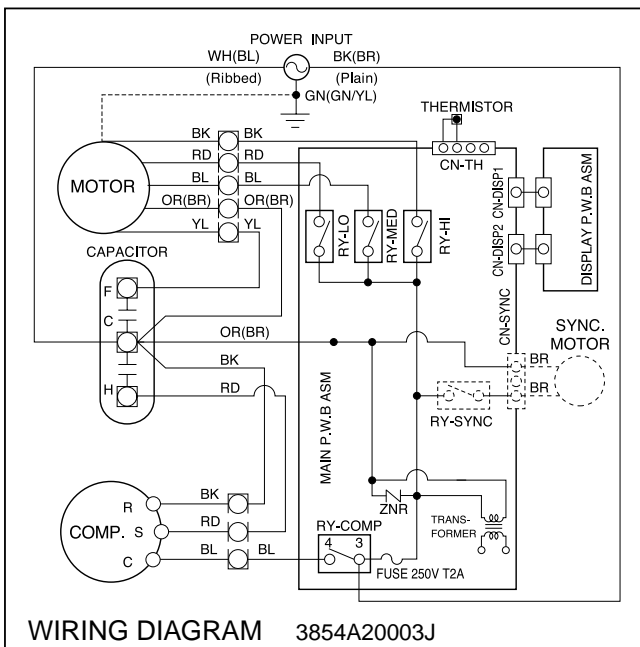

- MODEL : LWN2120QHJ

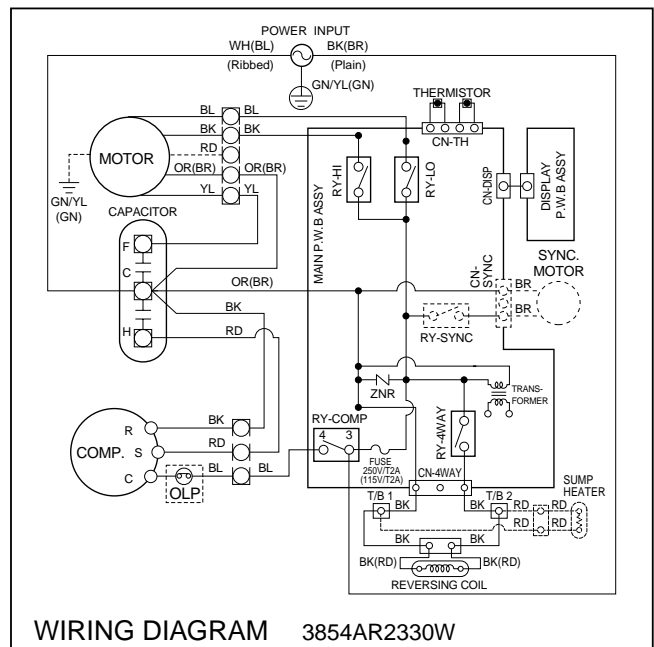

4.2 ELECTROINC CONTROL DEVICE

• MODEL: Micom Models

- NOTES**
1. The unit of undefined resistors is ohm, 1/6W, 5%.
 2. The unit of undefined capacitors is uf.

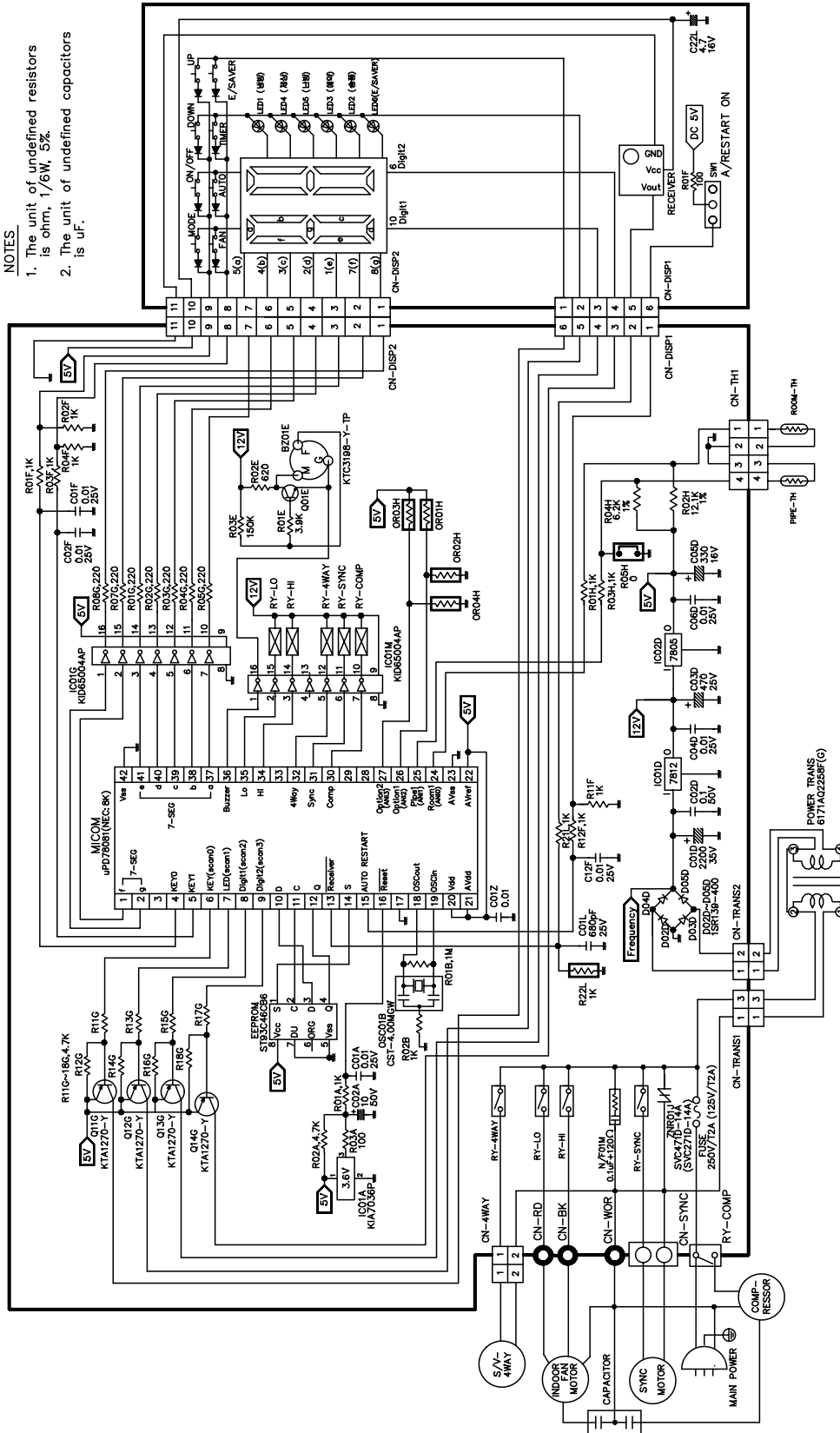

4.3 COMPONENTS LOCATION (OF MAIN P.C.B ASM)

- MODEL: LWM1860QCG/QCL/QAG, LWN1860QCG/QCL, LWN2260QCG/QCL
 LWM1820QCG/QCL, LWM1821QCG/QCL, LWN2120QCG/QCL
 LWM1830QCG/QCL, LWN2130QCG/QCL

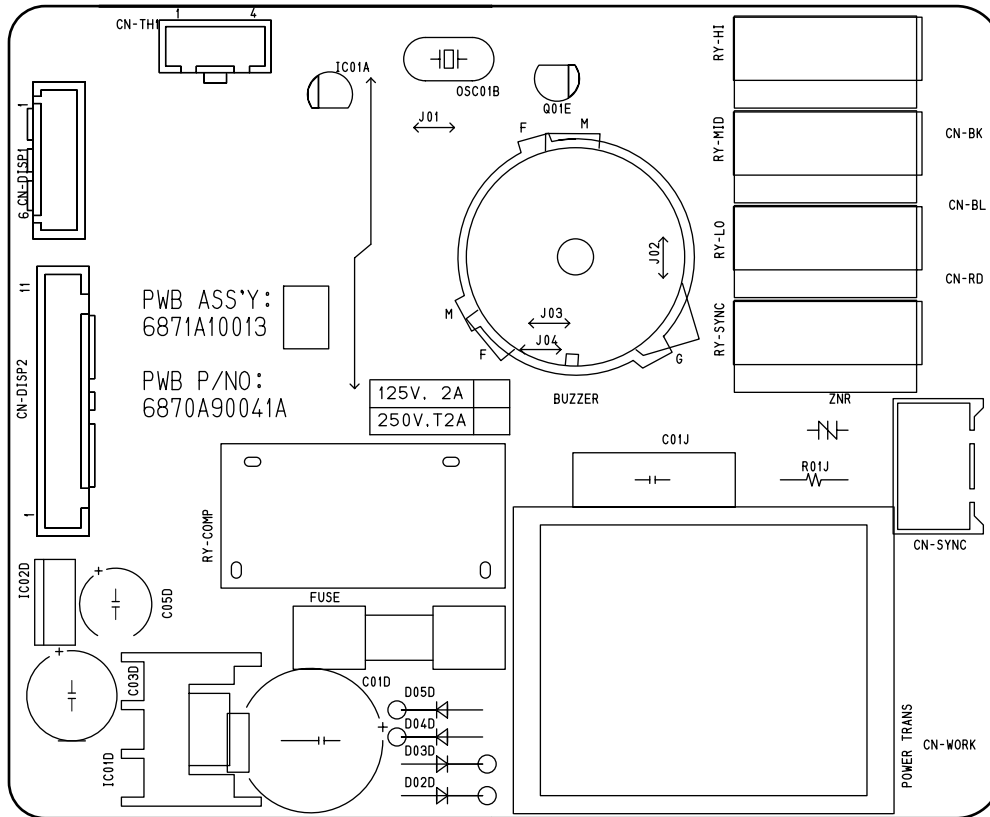

- MODEL: LWN2120BHG/BHP/QHG, LWN2123BHG

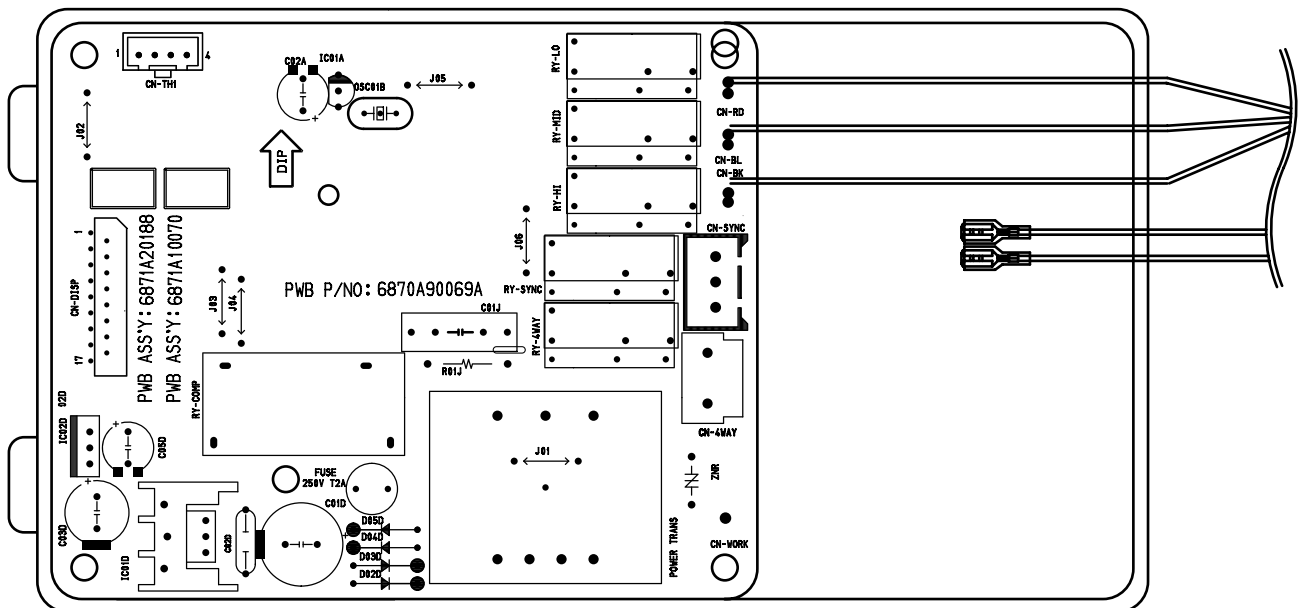

4.4 COMPONENTS LOCATION (FOR DISPLAY P.C.B ASM)

- MODEL: LWM1860QCG/QCL/QAG, LWM1860QCG/QCL, LWN2260QCG/QCL
LWM1820QCG/QCL, LWM1821QCG/QCL, LWN2120QCG/QCL
LWM1830QCG/QCL, LWN2130QCG/QCL

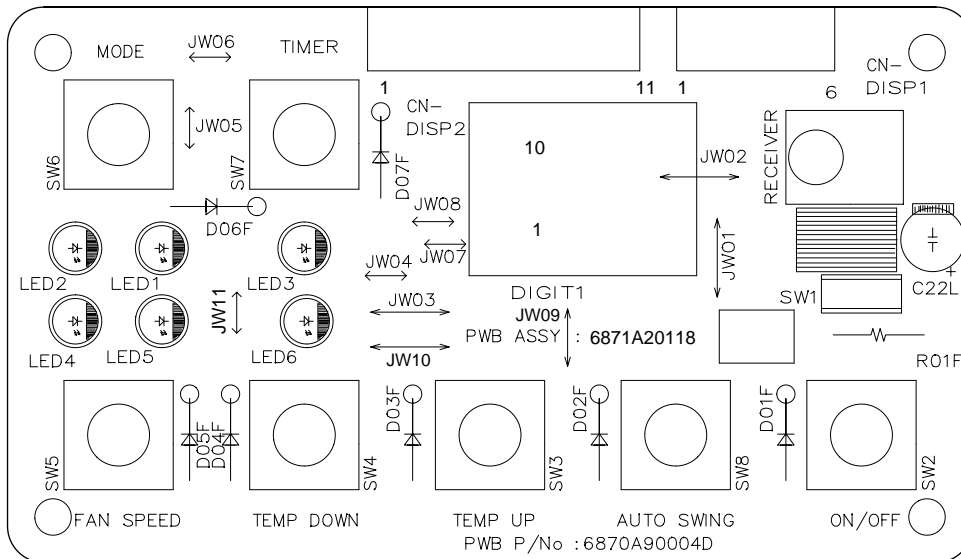

- MODEL: LWN2120BHG/BHP/QHG, LWN2123BHG

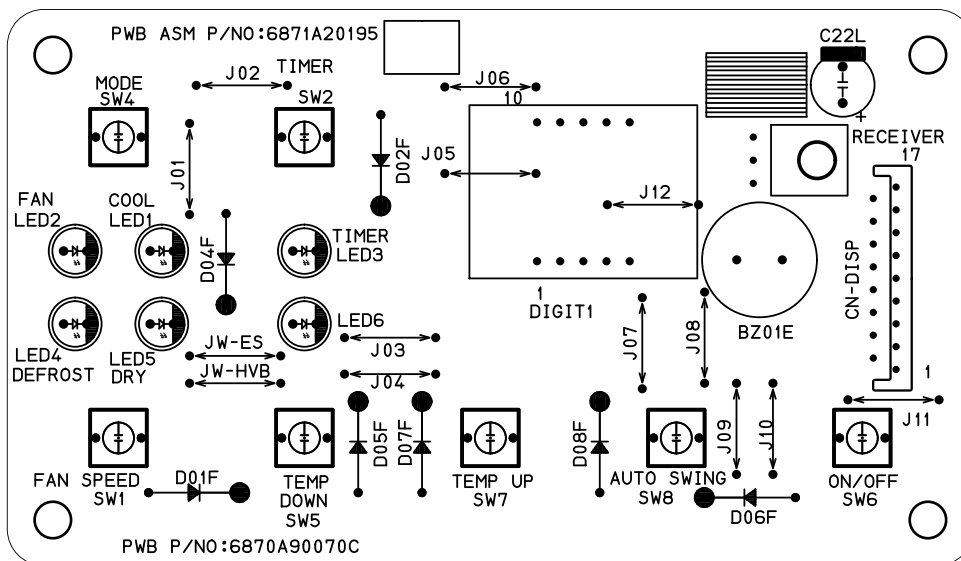

5. EXPLODED VIEW

• COOLING MODEL

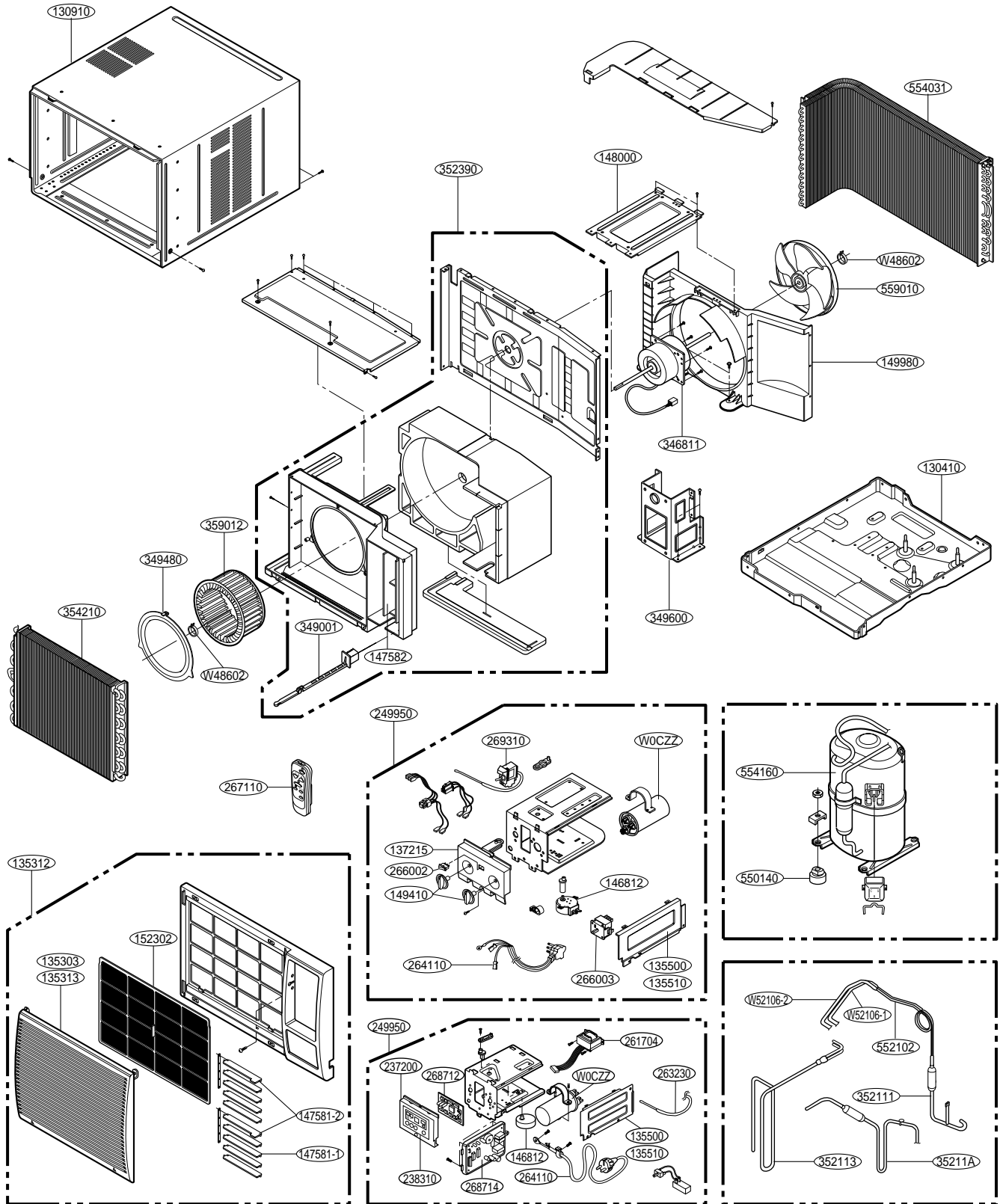

• HEATING MODEL

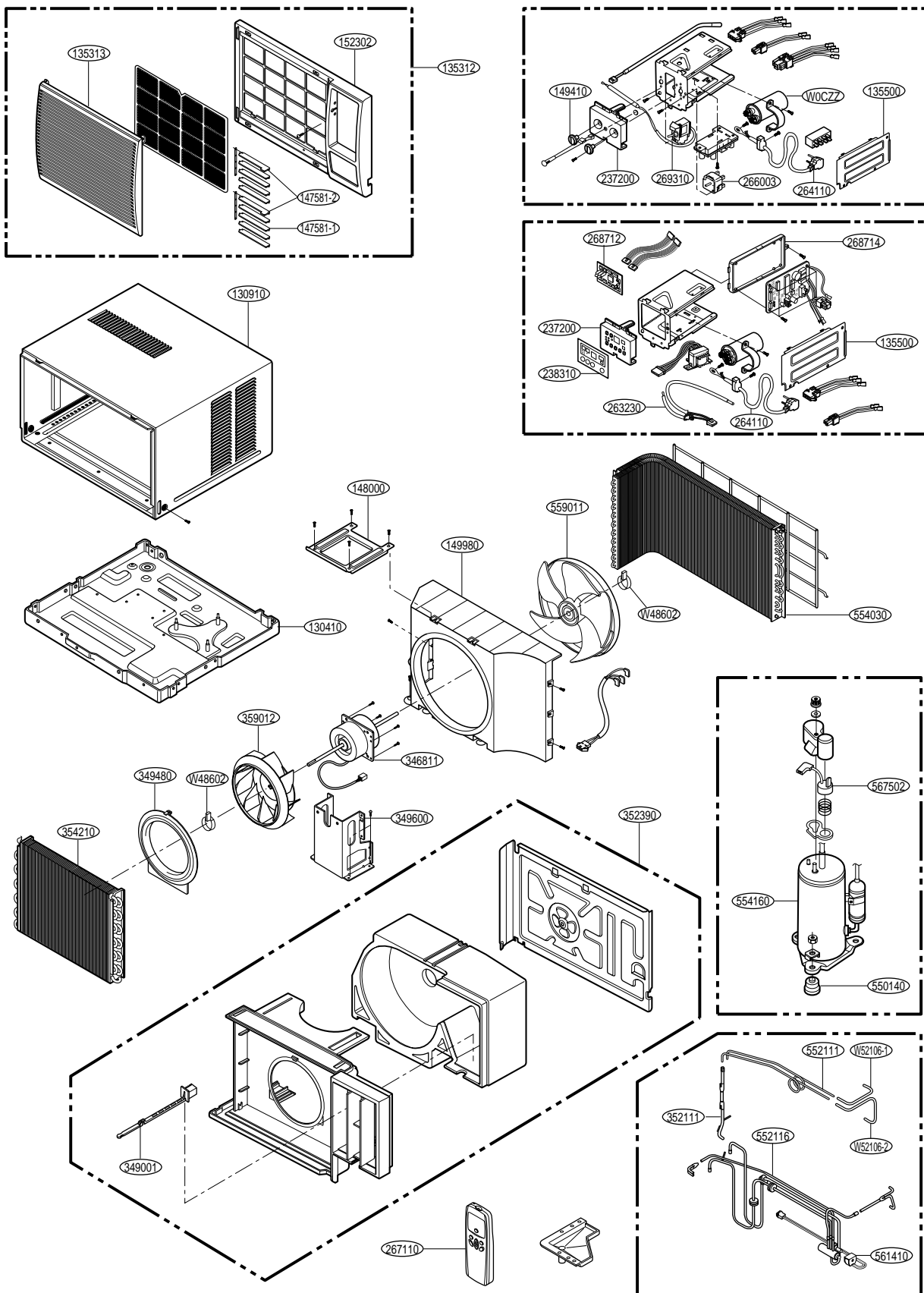

6. REPLACEMENT PARTS LIST

LOCATION NO.	DESCRIPTION	PART NO.						REMARK
		LWN1860 BCG(BCL)	LWM1860 BCG(BCL)	LWM1860 BCP	LWM1830 BCG(BCL)	LWM1860 BAG	LWN2123 BCG	
130410	BASE ASSEMBLY, SINGLE	3041A30001B	3041A30002F	3041A30002F	3041A30002B	3041A30002F	3041A30001K	R
130910	CABINET ASSEMBLY	3061AR6056B	3091AR6057B	3091AR6057B	3091AR6057B	3091AR6057B	3091AR6056B	R
135303	GRILLE, INLET	3530AR1604A(5236AR1329A)	3530AR1604A(5236AR1329A)	-	3530AR1604A(5236AR1329A)	3530AR1604A	3530AR1604D	R
135312	GRILLE ASSEMBLY, FRONT(SINGLE)	3531A20005A(3531AR2632D)	3531A20005A(3531AR2632D)	3531A20005K	3531A20005A(3531AR2632D)	3531A20005L	3531A20005V	R
135313	GRILLE INLET	-	-	3531A20005A	-	-	-	
135500	COVER, CONTROL BOX	3550AR7245A	3550AR7245A	-	3550AR7245A	-	-	R
135510	COVER ASSEMBLY, CONTROL	-	-	3551A30015A	-	-	3551A30015A	R
137215	PANEL ASSEMBLY, CONTROL	3721A20002A	3721A20002A	3721A20002A	3721A20002B	3721A20002A	3721A20035G	R
146812	MOTOR ASSEMBLY, SYNC	2H01102A	2H01102A	2H01102A	2H01102A	2H01102A	2H01102A	R
147581-1	LOUVER, HORIZONTAL	4758A7264A(-)	4758A7264A(-)	4758A7264A	4758A7264A(-)	4758A7264A(-)	4758AR7264F	R
147581-2	LOUVER, HORIZONTAL	4758AR7278A(-)	4758AR7278A(-)	4758AR7278A	4758AR7278A(-)	4758AR7278A(-)	4758AR7278F	R
147582	LOUVER, VERTICAL	4758AR6157A	4758AR6157A	4758AR6157A	4758AR6157A	4758AR6157A	4758AR6157A	R
148000	BRACE	4800AR7271A	4800AR7272A	4800AR7272A	4800AR7271A	4800AR7272A	4800AR7271A	R
149410	KNOB ASSEMBLY	4941A30001A(4941A30001B)	-	4941A30001A	4941A30001A(4941A30001B)	4941A30001A	4941A30001K	R
149980	SHROUD	4998AR1597A	4998AR1597A	4998AR1597A	4998AR1597A	4998AR1597A	4998AR1597A	R
152302	FILTER ASSEMBLY, A/C	5231AR6159A(5230AR1327A)	5231AR6159A(5230AR1327A)	5231AR6159A	5231AR6159A(5230AR1327A)	5231AR6159A(5230AR1327A)	5231AR6159D	R
249950	CONTROL BOX ASSEMBLY, SINGLE	4995A20005D	4995A20005V/Y	4995A20057Q	4995A20005P	4995A20057Q	4995A20088G	R
264110	POWER CORD ASSEMBLY	3H01307C	3H03555B	3H01307D	2H00677Q	3H01307D	3H01307C	R
266002	SWITCH, ROCKER	2H01316C	2H01316C	2H01316C	2H01316C	2H01316C	-	R
266003	SWITCH, ROTARY	2H00598E	2H00598E	2H00598E	2H00598E	2H00598E	2H00598E	R
269310	THERMOSTAT ASSEMBLY	2H01109L	2H01109M	2H01109M	2H01109L	2H01109M	2H01109M	R
346811	MOTOR ASSEMBLY, SINGLE	4681AR6033A	4681AR6033H	4681AR6033H	4681AR6033B	4681AR6033H	4681AR6033F	R
349001	DAMPER, VENTILATION	4900AR7256A	4900AR7256A	4900AR7256A	4900AR7256A	4900AR7256A	4900AR7265A	R
349480	ORIFICE	4948AR7241A	4948AR7241A	4948AR7241A	4948AR7241A	4948AR7241A	4948AR7241A	R
349600	MOTOR MOUNT	4960AR1596A	4960AR1596A	4960AR1596A	4960AR1596A	4960AR1596A	4960AR1596A	R
352111	TUBE ASSEMBLY, CONNECTION	5211AR7059C	5211AR7059A	5211AR7059W	5211AR7059E	5211AR7059A	5211AR7059C	R
352113	TUBE ASSEMBLY, DISCHARGE	5211A30003A	5211A30066B	5211A30066B	5211A30066A	5211A30066B	5211A30131A	R
35211A	TUBE ASSEMBLY, SUCTION	5211A30002A	5211A30154A	5211A30154A	5211A30065A	5211A30154A	5211A30130A	R
352390	AIR GUIDE ASSEMBLY	5239A20001A	5239A20001A	5239A20001A	5239A20001D	5239A20001A	5239A20001A	R
354210	EVAPORATOR ASSEMBLY	5421A20009A	5421A20009A	5421A20009A	5421A20017B	5421A20009A	5421A20017A	R
359012	FAN ASSEMBLY, BLOWER	5834AR1599A	5834AR1599A	5834AR1599A	5834AR1599A	5834AR1599A	5834AR1599B	R
550140	ISOLATOR, COMP	-	-	4022U-L005A	-	4022U-L005A	4H01765A	R
552101	TUBE CAPILLARY	5425AR3147A	3H03750L	-	3H03750S	-	5425AR3147X	R
552102	TUBE, CAPILLARY BEND	-	-	5211A20020C	-	5211A20020C	-	R
554031	CONDENSER ASSEMBLY, BENT	5403A20004B	5403A20004F	5403A20004F	5403A20004F	5403A20004K	5403A20004M	R
554160	COMPRESSOR	5416AR1411D	5416AR1581C	5416AR1581C	5417AR2256E	5416AR1581C	1H00404D	R
559010	FAN ASSEMBLY, AXIAL	5900AR1598A	5900AR1330A	5900AR1330A	5900AR1330A	5900AR1330A	5900AR1330A	R
W0CZZ	CAPACITOR	6120AR2194F	6120AR2194F	6120AR2194F	6120AR2194D	6120AR2194F	6120AR2194F	R
W48602	CLAMP SPRING	3H02932C	3H02932C	3H02932C	3H02932C	3H02932C	3H02932C	
W52106-1	TUBE, EVAPORATOR	5210A30009B	5210A30009G	5210A30009G	5210A30009D	5210A30009G	5210A30144A	R
W52106-2	TUBE, EVAPORATOR	5210A30009A	5210A30009H	5210A30009H	5210A30009C	5210A30009H	5210A30144B	R

LOCATION NO.	DESCRIPTION	PART NO.					REMARK
		LWN2260 BCG(BCL)	LWM1820/1 BCG(BCL)	LWN2120 BCG(BCL)	LWN2130 BCG(BCL)	LWN2131 BAG	
130410	BASE ASSEMBLY, SINGLE	3041A30002D	3041A30002B	3041A30001K	3041A30001H	3041A30001H	R
130910	CABINET ASSEMBLY	3061AR6056B	3091AR6057B	3091AR6057B	3091AR6057B	3091AR6056B	R
135303	GRILLE, INLET	3530AR1604A(5236AR1329A)	3530AR1604A(5236AR1329A)	3530AR1604A(5236AR1329A)	3530AR1604A(5236AR1329A)	3530AR1604A	R
135312	GRILLE ASSEMBLY, FRONT	3531A20005A(3531AR2632D)	3531A20005A(3531AR2632D)	3531A20005A(3531AR2632D)	3531A20005A(3531AR2632D)	3531A20005L	R
135500	COVER, CONTROL BOX	3550AR7245A	3550AR7245A	3550AR7245A	3550AR7245A	3550AR7245A	R
135510	COVER ASSEMBLY, CONTROL	-	-	-	-	3551A30015A	R
137215	PANEL ASSEMBLY, CONTROL	3721A20002A		3721A20002E	3721A20002B	3721A20002A	R
146812	MOTOR ASSEMBLY, SYNC	2H01102A	2H01102A	2H01102A	2H01102A	2H01102A	R
147581-1	LOUVER, HORIZONTAL	4758A7264A(-)	4758A7264A(-)	4758A7264A(-)	4758A7264A(-)	4758A7264A(-)	R
147581-2	LOUVER, HORIZONTAL	4758AR7278A(-)	4758AR7278A(-)	4758AR7278A(-)	4758AR7278A(-)	4758AR7278A(-)	R
147582	LOUVER, VERTICAL	4758AR6157A	4758AR6157A	4758AR6157A	4758AR6157A	4758AR6157A	R
148000	BRACE	4800AR7271A	4800AR7272A		4800AR7272A	4800AR7271A	R
149410	KNOB ASSEMBLY	4941A30001A(4941A30001B)	4941A30001A(4941A30001B)	4941A30001A(4941A30001B)	4941A30001A(4941A30001B)	4941A30001A	R
149980	SHROUD	4998AR1597A	4998AR1597A	4998AR1597A	4998AR1597A	4998AR1597A	R
152302	FILTER ASSEMBLY, A/C	5231AR6159A(5230AR1327A)	5231AR6159A(5230AR1327A)	5231AR6159A(5230AR1327A)	5231AR6159A(5230AR1327A)	5231AR6159A	R
249950	CONTROL BOX ASSEMBLY, SINGLE	4995A20005B/C	4995A20005G	4995A20005S	4995A20005P	4995A20065J	R
264110	POWER CORD ASSEMBLY	3H01307C	3H01307C	3H01307C	2H00677Q	2H00677Q	R
266002	SWITCH, ROCKER	2H01316C	2H01316C	2H01316C	2H01316C	2H01316C	R
266003	SWITCH, ROTARY	2H00598E	2H00598E	2H00598E	2H00598E	2H00598E	R
269310	THERMOSTAT ASSEMBLY	2H01109L	2H01109L	2H01109M	2H01109L	2H01109L	R
346811	MOTOR ASSEMBLY, SINGLE	4681A20011A	4681AR6033C	4681AR6033F	4681AR6033G	4681AR6033M	R
349001	DAMPER, VENTILATION	4900AR7256A	4900AR7256A	4900AR7256A	4900AR7256A	4900AR7256A	R
349480	ORIFICE	4948AR7241A	4948AR7241A	4948AR7241A	4948AR7241A	4948AR7241A	R
349600	MOTOR MOUNT	4960AR2895A	4960AR1596A	4960AR1596A	4960AR1596A	4960AR1596A	R
352111	TUBE ASSEMBLY, CONNECTION	5211AR7059C	5211AR7059C	5211AR7059C	5211AR7059E	5211AR7059H	R
352113	TUBE ASSEMBLY, DISCHARGE	5211A30003A	5211A30066A	5211A30131A	5211A30137A	5211A30293A	R
35211A	TUBE ASSEMBLY, SUCTION	5211A30064A	5211A30088B	5211A30130A	5211A30136A	5211A30292A	R
352390	AIR GUIDE ASSEMBLY	5239A20001A	5239A20001A	5239A20001A	5239A20001A	5239A20001A	R
354210	EVAPORATOR ASSEMBLY	5421A20017A	5421A20017A	5421A20017A	5421A20017B	-	R
359012	FAN ASSEMBLY, BLOWER	5834AR1599A	5834AR1599A	5834AR1599A	5834AR1599A	5834AR1599A	R
550140	ISOLATOR, COMP	-	-	-	-	-	R
552101	TUBE CAPILLARY	5424AR3448L	5425AR3147T	5425AR3147X	5424AR3411P	-	R
552102	TUBE, CAPILLARY BEND	-	-	-	-	5211A30296A	R
554031	CONDENSER ASSEMBLY, BENT	5403A20004B	5403A20004F	5403A20004B	5403A20013D	5403A20004T	R
554160	COMPRESSOR	5416AR1411E	5417AR2256S	5416AR1422A	2H01564J	5416A20013E	R
559010	FAN ASSEMBLY, AXIAL	5900AR1598A	5900AR1330A	5900AR1330A	5900AR1508A	5900AR1330A	R
W0CZZ	CAPACITOR	6120AR2194L	6120AR2194P	6120AR2194F	6120AR2194D	6120AR2194K	R
W48602	CLAMP SPRING	3H02932C	3H02932C	3H02932C	3H02932C	3H02932C	R
W52106-1	TUBE, EVAPORATOR	5210A30144B	5210A30009J	5210A30144B	5210A30009D	5210A30144B	R
W52106-2	TUBE, EVAPORATOR	5210A30144A	5210A30009K	5210A30144A	5210A30009C	5210A30144A	R

LOCATION NO.	DESCRIPTION	PART NO.							REMARK	
		LWN1860 QCG(QCL)	LWN2260 QCG(QCL)	LWM1860 QCG(QCL)	LWM1820/1 QCG(QCL)	LWN2120 QCG(QCL)	LWM1830 QCG(QCL)	LWN2130 QCG(QCL)		
135312	FRONT GRILLE ASS'Y	3531A20005A (3531AR2632D)							R	
135313	INLET GRILLE	3530AR1604A (5236AR1329A)							R	
152302	AIR FILTER ASS'Y	5231AR6159A (5230AR1327A)							R	
147581-1	LOUVER HORIZONTAL	4758AR7264A(-)							R	
147581-2	LOUVER HORIZONTAL	4758AR7278A(-)							R	
554160	COMPRESSOR ASS'Y	5417AR2767F	5417AR2767G	5417AR6146E	5417AR2652B	2H01277W	5417AR2652A	2H02564H	R	
130910	CABINET ASS'Y	3091AR6056B		3091AR6057B			3091AR6056B		R	
147582	LOUVER VERTICAL	4758AR6157A							R	
349001	DAMPER	4900AR7265A							R	
349600	MOTOR MOUNT	4960AR1596A	4960AR2895A	4960AR4596A					R	
346811	MOTOR ASS'Y	4681AR6033A	4681A20011A	4681AR6033H	4681AR6033C	4681AR6033F	4681AR6033B	4681AR6033G	R	
359012	BLOWER	5834AR1599A							R	
352390	AIR GUIDE ASS'Y	5239A20001A				5239A20001D		5239A20001A		R
W48602	CLAMP	3H02932C							R	
349480	ORIFICE	4948AR7241A							R	
354210	EVAPORATOR ASS'Y	5421A20009A	5421A20017A	5421A20009A	5421A20017A		5421A20017B		R	
149980	SHROUD	4998AR1597A							R	
559011	FAN	5900AR1598A		5900AR1330A			5900AR1508A	5900AR1330A	R	
554031	CONDENSER ASS'Y	5403A20004B		5403A20004F		5403A20004B	5403A20004F	5403A20013D	R	
148000	BRACE	4800AR7271A		4800AR7272A		4800AR7271A	4800AR7272A	4800AR7271A	R	
249950	CONTROL BOX ASS'Y	4995A20045A	4995A20045B	4995A20045L			4995A20045C		R	
268712	DISPLAY PWB ASM	6871A30005A							R	
268714	MAIN PWB ASM	6871A20037H				6871A20037K				R
W0CZZ	CAPACITOR	6120AR2194F	6120AR2194D	6120AR2194F	6120AR2194F	6120AR2194F	6120AR2194D		R	
264110	POWER CORD ASS'Y	3H01307C		3H03555B	3H01307C		2H00677Q		R	
263230	THERMISTOR ASS'Y	6323AQ2333K							R	
237200	CONTROL PANEL	3720AR6163A							R	
238310	ESCUTCHEON	3841A10002A				3831A10002B				R
146812	SYNCHRONOUS MOTOR	2H01102A							R	
135500	COVER CONTROL BOX	3550AR7245A							R	
261704	TRANSFORMER ASS'Y	6171AQ2258F							R	
35211A	TUBE SUCTION ASS'Y	5211A30002A	5211A30064A	5211A30154A	5211A30088B	521130130A	5211A30065A	5211A30136A	R	
352113	TUBE DISCHARGE ASS'Y	5211A30003A		5211A30066B	5211A30066A	5211A30131A	5211A30066A	5211A30137A	R	
352111	TUBE CONNECTION ASS'Y	5211AR7059C		5211AR7059A	5211AR7059C			5211AR7059E	R	
552101	TUBE CAPILLARY	5425AR3147A	5424AR3448L	3H03750L	5425AR3147T	5425AR3147X	3H03750S	5424AR3411P	R	
267110	REMOTE CONTROLLER ASSEMBLY	6711AR2700B		6711A20018M (6711AR2700B)	6711A20018M		6711AR2700L		R	
130410	BASE ASSEMBLY, SINGLE	3041A30001B	3041A30001D	3041A30002F	3041A30002B	3041A30001K	3041A30002B	3041A30001H	R	

LOCATION NO.	DESCRIPTION	PART NO.			REMARK
		LWM1860QAG	LWM2130AAG	LWM2130BAG	
130410	BASE ASSEMBLY, SINGLE	3041A30002F	3041A30002B	3041A30002B	R
130910	CABINET ASSEMBLY, SINGLE	3091AR6057B	3091AR6057B	3091AR6057B	R
135312	GRILLE ASSEMBLY, FRONT(SINGLE)	3531A20005L	3531A20005L	3531A20005L	R
135313	GRILLE, INLET	3530AR1604A	3530AR1604A	3530AR1604A	R
135500	COVER	-	3550A30048C	3550A30048C	R
135510	COVER ASSEMBLY, CONTROL(SINGLE)	3551A30015A	3551A30015A	3551A30015A	R
137215	PANEL ASSEMBLY, CONTROL	-	3721A20035Y	3721A20002A	R
146812	MOTOR ASSEMBLY, SYNC.	2H01102A	-	2H01102A	R
147581-1	LOUVER, HORIZONTAL	4758AR7264A	4758AR7264A	4758AR7264A	R
147581-2	LOUVER, HORIZONTAL	4758AR7278A	4758AR7278A	4758AR7278A	R
147582	LOUVER, VERTICAL	4758AR6157A	-	4758AR6157A	R
148000	BRACE	4800AR7272A	4800AR7272A	4800AR7272A	R
149410	KNOB ASSEMBLY	4940AR7022A	4941A30001A	4941A30001A	R
149980	SHROUD	4998AR1597A	4998AR1597A	4998AR1597A	R
152302	FILTER ASSEMBLY, A/C	5231AR6159A	5231AR6159A	5231AR6159A	R
237200	PANEL, CONTROL	3720AR6163A	-	-	R
238310	ESCUTCHEON	3831A10002H	-	-	R
249950	CONTROL BOX ASSEMBLY, SINGLE	4995A20100A	4995A20088K	4995A20088M	R
261704	TRANSFORMER, POWER	6170A20006A	-	-	R
263230	THERMISTOR ASSEMBLY	6323A20003D	-	-	R
264110	POWER CORD ASSEMBLY	3H01307C	2H00677Q	2H00677Q	R
266002	SWITCH, ROCKER	-	-	2H01316C	R
266003	SWITCH, ROTARY	-	2H00598E	2H00598E	R
267110	REMOTE CONTROLLER ASSEMBLY	6711A20034N	-	-	R
268712	PWB(PCB) ASSEMBLY, DISPLAY	6871A20118C	-	-	R
268714	PWB(PCB) ASSEMBLY, MAIN	6871A10013A	-	-	R
269310	THERMOSTAT ASSEMBLY	-	2H01109L	2H01109L	R
346811	MOTOR ASSEMBLY, SINGLE	4681AR6033H	4681AR6033U	4681AR6033U	R
349001	DAMPER, VENTILATION	4900AR7265A	4900AR7265A	4900AR7265A	R
349480	ORIFICE	4948AR7241A	4948AR7241A	4948AR7241A	R
349600	MOUNT, MOTOR	4960AR1596A	4960AR1596A	4960AR1596A	R
352111	TUBE ASSEMBLY, CONNECTOR	5211AR7059A	5211AR7059C	5211AR7059C	R
352113	TUBE ASSEMBLY, DISCHARGE SINGLE	5211A30066B	5211A30066L	5211A30066L	R
W52106-1	TUBE, EVAPORATOR	5210A30009G	5210A30144J	5210A30144J	R
W52106-2	TUBE, EVAPORATOR	5210A30009H	5210A30144K	5210A30144K	R
35211A	TUBE ASSEMBLY, SUCTION SINGLE	5211A30154A	5211A30292D	5211A30292D	R
352390	AIR GUIDE ASSEMBLY	5239A20001A	5239A20001C	5239A20001J	R
354210	EVAPORATOR ASSEMBLY, FIRST	5421A20009A	5421A20017G	5421A20017G	R
359012	FAN ASSEMBLY, BLOWER	5834AR1599A	5834AR1599B	5834AR1599B	R
550140	ISOLATOR, COMP	-	5040A30017A	5040A30017A	R
552102	TUBE, CAPILARY BEND	5211A20020C	5211A20020T	5211A20020T	R
554030	CONDENSER ASSEMBLY, FIRST	-	5403A20004Y	5403A20004Y	R
554031	CONDENSER ASSEMBLY, BENT	5403A20004K	-	-	R
554160	COMPRESSOR	5416AR1581C	5416A20013E	5416A20013E	R
559010	FAN ASSEMBLY, AXIAL	5900AR1330A	5900AR1330A	5900AR1330A	R
W0CZZ	CAPACITOR, DRAWING	6120AR2194F	6120AR2194K	-	R
W48602	CLAMP, SPRING	3H02932C	3H02932C	3H02932C	R

LOCATION NO.	DESCRIPTION	PART NO.				REMARK
		LWN2120BHG	LWN2120BHP	LWN2120QHG	LWN2123BHG	
130410	BASE ASSEMBLY,SINGLE	3041A30001K	3041A30001K	3041A30001K	3041A30001K	R
130910	CABINET ASSEMBLY,SINGLE	3091AR6056B	3091AR6056B	3091AR6056B	3091AR6056B	R
135312	GRILLE ASSEMBLY,FRONT(SINGLE)	3531A20005X	3531A20005U	3531A20005F	3531A20005V	R
135313	GRILLE,INLET	3530AR1604A	3530A10005B	3530AR1604A	3530AR1604D	R
135510	COVER ASSEMBLY,CONTROL(SINGLE)	3551A30015A	3551A30015A	3551A30015A	3551A30015A	R
137215	PANEL ASSEMBLY,CONTROL	3721A20002D	3721A20035H	-	3721A20035H	R
146812	MOTOR ASSEMBLY,SYNC.	2H01102A	2H01102A	2H01102A	2H01102A	R
147581-1	LOUVER,HORIZONTAL	4758AR7264A	4758AR7264F	4758AR7264A	4758AR7264F	R
147581-2	LOUVER,HORIZONTAL	4758AR7278A	4758AR7278F	4758AR7278A	4758AR7278F	R
147582	LOUVER,VERTICAL	4758AR6157A	4758AR6157A	4758AR6157A	4758AR6157A	R
148000	BRACE	4800AR7271A	4800AR7271A	4800AR7271A	4800AR7271A	R
149410	KNOB ASSEMBLY	4941A30001A	4941A30001L	-	4941A30001K	R
149980	SHROUD	4998AR1597A	4998AR1597A	4998AR1597A	4998AR1597A	R
152302	FILTER ASSY,A/C	5231AR6159A	5231AR6159D	5231AR6159A	5231AR6159D	R
237200	PANEL,CONTROL	-	-	3720AR6163A	-	R
238310	ESCUTCHEON	-	-	3831A20032C	-	R
249950	CONTROL BOX ASSEMBLY,SINGLE	4995A20032D	4995A20032R	4995A20101A	4995A20032Q	R
261704	TRANSFORMER,POWER	-	-	6170A20006A	-	R
263230	THERMISTOR ASSEMBLY	3Q35015N	3Q35015N	6323A20003E	3Q35015N	R
264110	POWER CORD ASSEMBLY	3H01307C	3H01307C	3H01307D	3H01307C	R
266002	SWITCH,ROCKER	2H01316C	2H01316C	-	2H01316C	R
266003	SWITCH,ROTARY	2H00598F	2H00598F	-	2H00598F	R
267110	REMOTE CONTROLLER ASSEMBLY	-	-	6711A20018B	-	R
268712	PWB(PCB) ASSEMBLY,DISPLAY	-	-	6871A20195G	-	R
268714	PWB(PCB) ASSEMBLY,MAIN	-	-	6871A20188W	-	R
269310	THERMOSTAT ASSEMBLY	2H01127D	2H01127D	-	2H01127D	R
346811	MOTOR ASSEMBLY,SINGLE	4681AR6033F	4681AR6033F	4681AR6033F	4681AR6033F	R
349001	DAMPER,VENTILATION	4900AR7265A	4900AR7265A	4900AR7265A	4900AR7265A	R
349480	ORIFICE	4948AR7241B	4948AR7241B	4948AR7241B	4948AR7241B	R
349600	MOUNT,MOTOR	4960AR1596A	4960AR1596A	4960AR1596A	4960AR1596A	R
W52106-1	TUBE,EVAPORATOR	5210A30144E	5210A30144E	5210A30144E	5210A30144E	R
W52106-2	TUBE,EVAPORATOR	5210A30144F	5210A30144F	5210A30144F	5210A30144F	R
352390	AIR GUIDE ASSEMBLY	5239A20001B	5239A20001B	5239A20001B	5239A20001B	R
354210	EVAPORATOR ASSEMBLY,FIRST	5421A20017E	5421A20017E	5421A20017E	5421A20017E	R
359012	FAN ASSEMBLY,BLOWER	5834AR1599B	5834AR1599B	5834AR1599B	5834AR1599B	R
550140	ISOLATOR,COMP	4H01765A	4H01765A	4H01765A	4H01765A	R
552101	TUBE,CAPILLARY	3H03750H	3H03750H	3H03750H	3H03750H	R
554031	CONDENSER ASSEMBLY,BENT	5403A20013H	5403A20013H	5403A20013H	5403A20013R	R
554160	COMPRESSOR ASSEMBLY	1H00404D	1H00404D	1H00404D	1H00404D	R
559010	FAN ASSEMBLY,AXIAL	5900AR1330A	5900AR1330A	5900AR1330A	5900AR1330A	R
W0CZZ	CAPACITOR,DRAWING	6120AR2194F	6120AR2194F	6120AR2194F	6120AR2194F	R
W48602	CLAMP,SPRING	3H02932C	3H02932C	3H02932C	3H02932C	R
552116	TUBE ASSY,REVERSING	5211A30180A	5211A30180A	5211A30180A	5211A30180A	R
552202	VALVE,REVERSING	3A02027A	3A02027A	3A02027A	3A02027A	R
553000	HEATER,SUMP	2A00093L	2A00093L	2A00093L	2A00093L	R
561410	COIL ASSEMBLY,REVERSING VALVE	3A02028Z	3A02028Z	3A02028Z	3A02028Z	R

MEMO

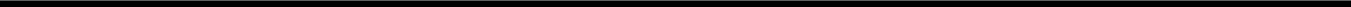

A series of horizontal dotted lines spaced evenly down the page, serving as a template for writing.

