

This Owner's Manual is provided and hosted by [Appliance Factory Parts](http://www.ApplianceFactoryParts.com).

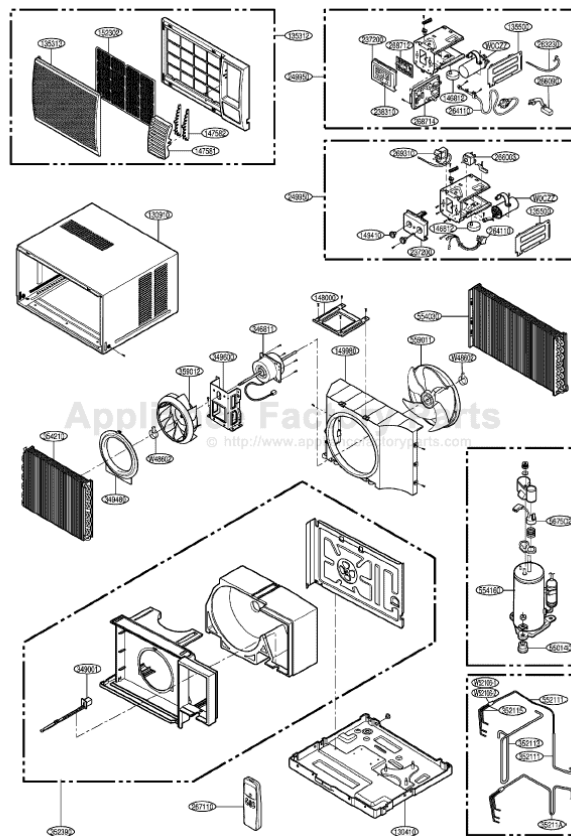

# LG TWC126CEAB0 Owner's Manual

[Shop genuine replacement parts for LG TWC126CEAB0](#)



[Find Your LG Air Conditioner Parts - Select From 2328 Models](#)

----- Manual continues below -----



website <http://www.lgservice.com>

LG

# LG

## Room Air Conditioner

### ***SERVICE MANUAL***

**MODEL: TWC123CBAD0**

**TWC123CBMM0**

**TWC126CBAB0/CBAB1/CEAB0/CNAB1/CSAB0**

**TWC126CBMM0/CBMM1/CEMM0/CSMM0**

#### CAUTION

- BEFORE SERVICING THE UNIT, READ THE SAFETY PRECAUTIONS IN THIS MANUAL.
- ONLY FOR AUTHORIZED SERVICE PERSONNEL.

# TABLE OF CONTENTS

<b>Safety Precautions</b> .....	3
<b>Dimensions</b> .....	5
Outside Dimensions .....	5
<b>Installation</b> .....	6
Select the Best Location .....	6
Installation Check .....	6
How to Secure the Drain Pipe .....	6
How to Install(Models without Installation Kit) .....	7
How to Install(Models with Installation Kit) .....	8
Suggested Tool Requirements .....	9
<b>Operation</b> .....	12
Features .....	12
Control Locations Function of Controls .....	12
<b>Disassembly</b> .....	15
Mechanical Parts.....	15
Air Handling Parts .....	16
Electrical Parts .....	17
Refrigerating Cycle.....	19
<b>Troubleshooting Guide</b> .....	22
Piping System .....	22
Troubleshooting Guide .....	23
Electrical Parts Troubleshooting Guide .....	25
Room Air Conditioner Voltage Limits.....	33
<b>Schematic Diagram</b> .....	36
Electronic Control Device .....	36
Wiring Diagram.....	37
Decier P.C.B ASM .....	44
Components Location (For Main P.C.B ASM) .....	45
Components Location (For Display P.C.B ASM) .....	45
<b>Product Specifications</b> .....	44
<b>Exploded View</b> .....	48
<b>Replacement Parts List</b> .....	50

# Safety Precautions



To prevent injury to the user or other people and property damage, the following instructions must be followed.

■ Incorrect operation due to ignoring instruction will cause harm or damage. The seriousness is classified by the following indications.

**⚠ WARNING** This symbol indicates the possibility of death or serious injury.

**⚠ CAUTION** This symbol indicates the possibility of injury or damage to property only.

■ Meanings of symbols used in this manual are as shown below.

	<b>Be sure not to do.</b>
	<b>Be sure to follow the instruction.</b>

## ⚠ WARNING

### ■ Installation

**Do not use damaged power cord plugs, or a loose socket.**

• There is risk of fire or electric shock.

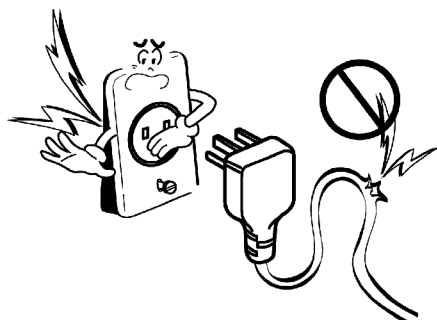

**Always use the power plug and socket with the ground terminal.**

• There is risk of electric shock.

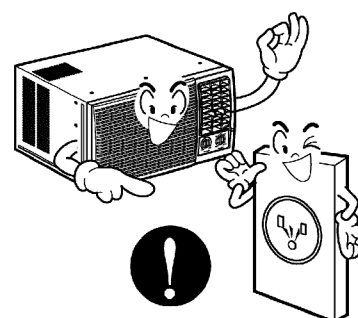

## Safety Precautions

---

### Do not modify or extend the power cord.

- There is risk of fire or electric shock.

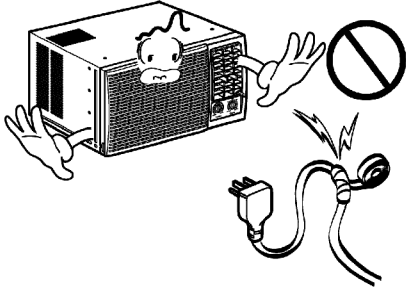

### Do not install, remove, or re-install the unit by yourself(customer).

- There is risk of fire, electric shock, explosion, or injury.

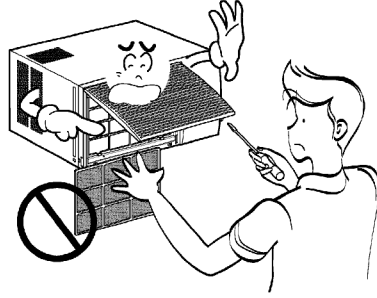

### Be cautious when unpacking and installing the product.

- Sharp edges could cause injury. Be especially careful of the case edges and the fins on the condenser and evaporator.

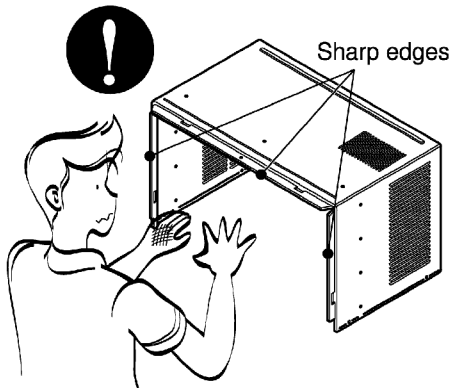

### Do not store or use flammable gas or combustibles near the air conditioner.

- There is risk of fire or failure of product.

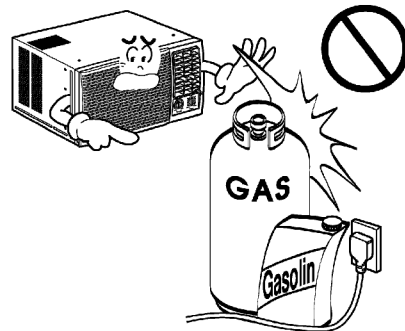

### Be sure the installation area does not deteriorate with age.

- If the base collapses, the air conditioner could fall with it, causing property damage, product failure, and personal injury.

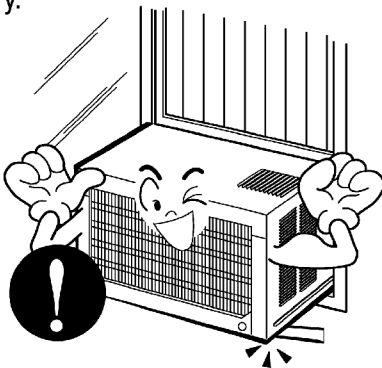

# Dimensions

## Symbols Used in this Manual



This symbol alerts you to the risk of electric shock.



This symbol alerts you to hazards that could cause harm to the air conditioner.

**NOTICE**

This symbol indicates special notes.

## Outside Dimensions

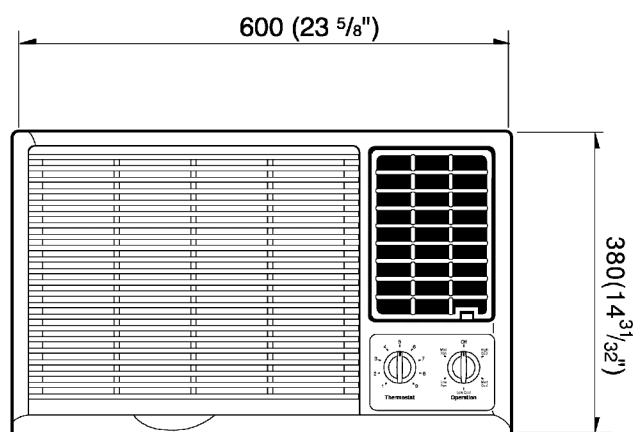
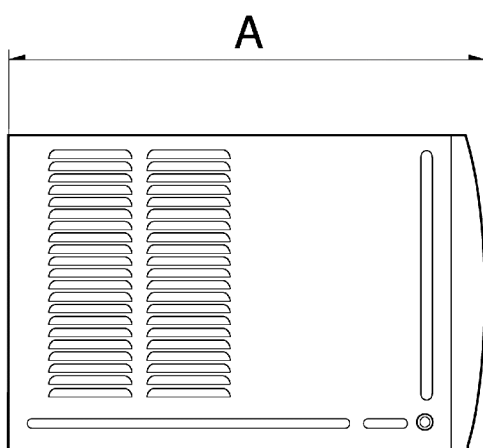

Look	A
G/P/B	567(22 5/16")
E/N	555(21 6/7")

# Installation

## Select the Best Location

1. To prevent vibration and noise, make sure the unit is installed securely and firmly.
2. Install the unit where the sunlight does not shine directly on the unit.
3. The outside of the cabinet must extend outward for at least 12" and there should be no obstacles, such as a fence or wall, within 20" from the back of the cabinet because it will prevent heat radiation of the condenser. Restriction of outside air will greatly reduce the cooling efficiency of the air conditioner.



**CAUTION: All side louvers of the cabinet must remain exposed to the outside of the structure.**

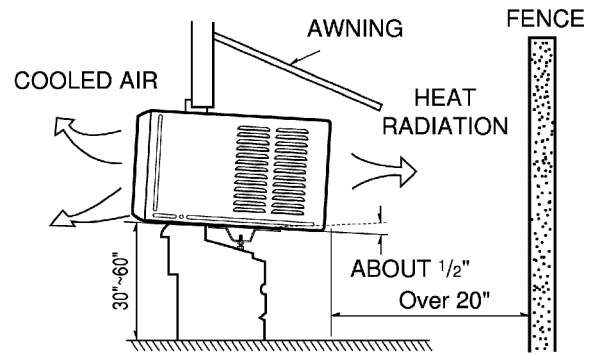

Figure 1

4. Install the unit a little slanted so the back is slightly lower than the front (about 1/2"). This will help force condensed water to the outside.
5. Install the unit from the bottom about 30"~60" above the floor level.

## Installation Check

The setting conditions must be checked prior to initial starting.

The following items are especially important checking points when the installation is finished.

1. Grounding wire (Green or Green and Yellow) is provided in the power cord. The green wire must be grounded.
2. Connect to a single-outlet 15A circuit.  
(or 20A circuit for Electric Heater Model)
3. To avoid vibration or noise, make sure the air conditioner is installed securely.
4. Avoid placing furniture or draperies in front of the air inlet and outlet.

## How to Secure the Drain Pipe(When using drain pipe)

In humid weather, excess water may cause the BASE PAN to overflow. To drain the water, remove the DRAIN CAP and secure the DRAIN PIPE to the rear hole of the BASE PAN. Press the drain pipe into the hole by pushing down and away from the fins to avoid injury.

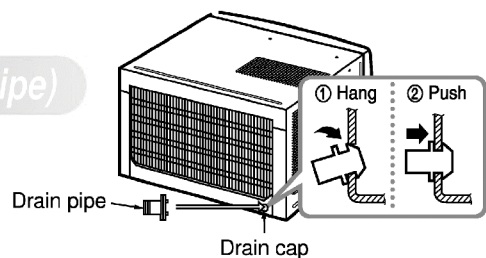

## Optional

1. Install the drain pan over the corner of the cabinet where you removed the plug with 4 (or 2) screws.
2. Connect the drain hose to the outlet located at the bottom of the drain pan. You can purchase the drain hose or tubing locally to satisfy your particular needs. (Drain hose is not supplied).
3. Select the most appropriate connection from among the following figures (by considering the hole of the unit) to fit drain pan to your own unit.

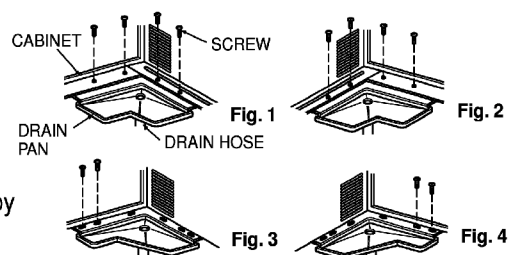

## How to Install (Models without Installation Kit)

1. Remove the screws that fasten the cabinet at both sides and at the back.

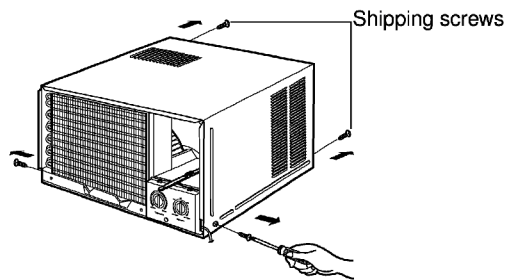

2. Slide the unit from the cabinet by gripping the base pan handle and pulling forward while bracing the cabinet.

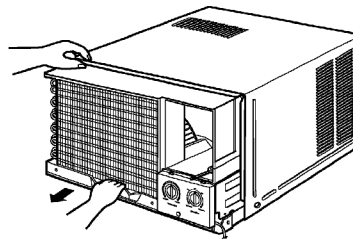

3. Remove EPS Material.

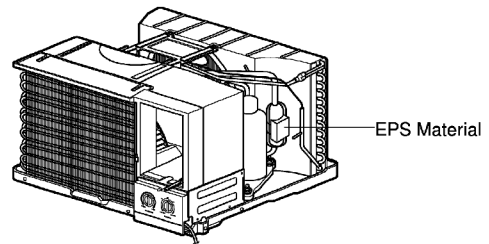

4. Slide the unit into the cabinet.



**CAUTION:** For security purpose, reinstall screw at cabinet's sides.

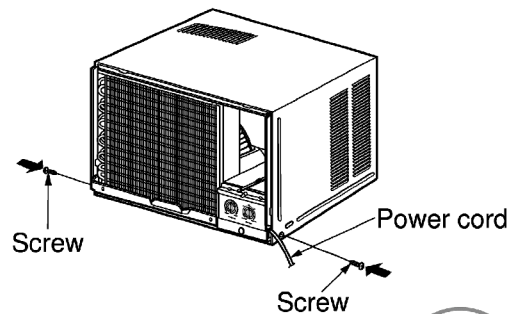

5. Attach the front grille to the cabinet by inserting the tabs on the grille into the tabs on the front of the cabinet. Push the grille in until it snaps into place.

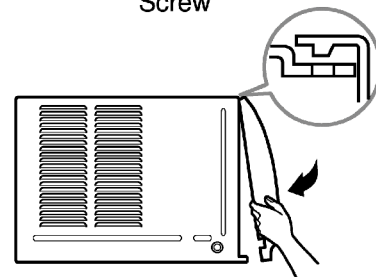

6. Lift the inlet grille and secure it with a screw through the front grille.

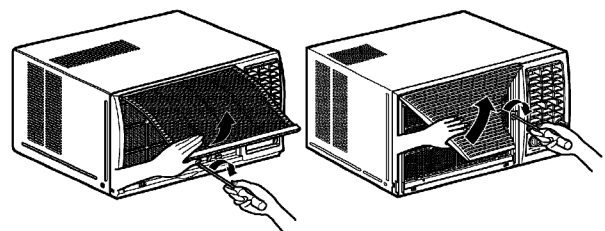

**How to Install(Models with Installaion Kit : 8~11page)**

**When Using Gasket**

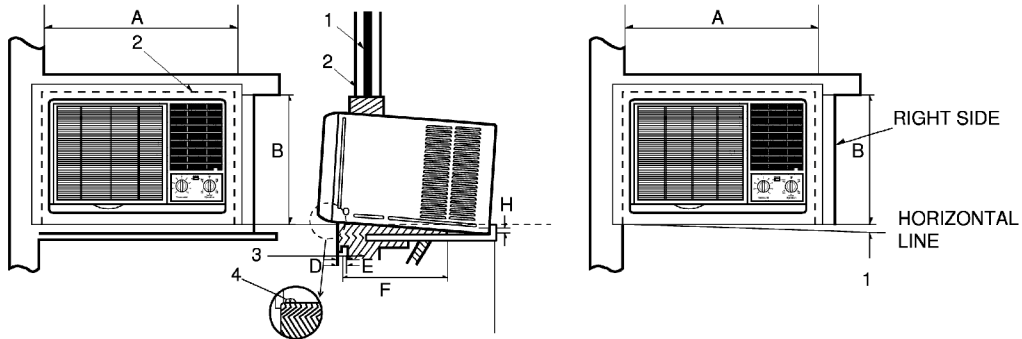

- 1. WINDOW (WIDTH-A, HEIGHT-B)
- 2. GASKET
- 3. WALL

- 4. DETAILS 5.1 x 30 ROUND HEAD WOOD SCREWS

A	B	C	D	E	F	H	I
625mm (24 <sup>5</sup> / <sub>8</sub> "	392mm (15 <sup>7</sup> / <sub>16</sub> "	280mm (11 <sup>1</sup> / <sub>32</sub> "	30mm (1 <sup>1</sup> / <sub>16</sub> "	0~25mm (0~1")	OVER 420mm (OVER 16 <sup>17</sup> / <sub>32</sub> "	5~10mm (3/16"~3/8")	-5~5mm (-3/16"~3/16")

**When Using Installation Kits**

**1. Window Requirements**

This unit is designed for installation in standard double hung windows with actual opening widths from 27" to 39".  
The top and bottom window sash must open sufficiently to allow a clear vertical opening of 16" from the bottom of the upper sash to the window stool.

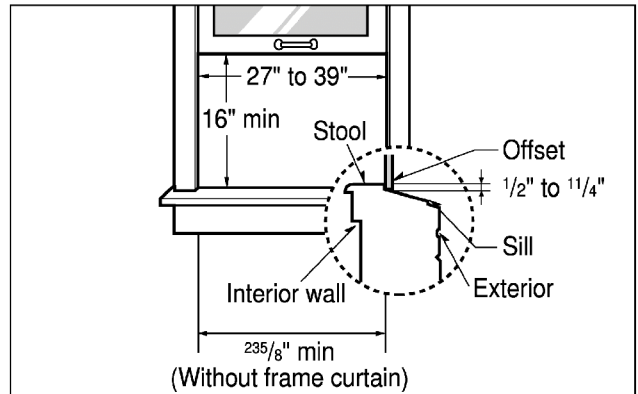

**2. Installation Kits Contents**

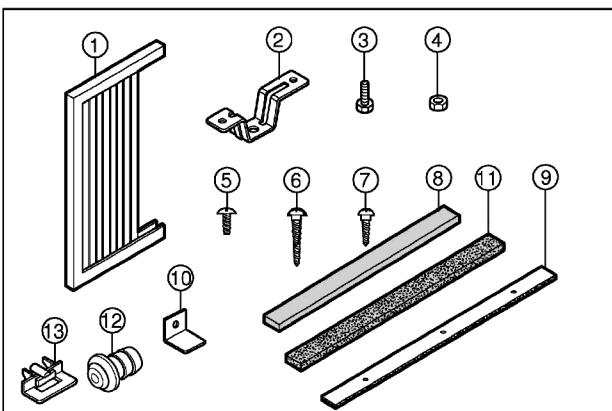

NO.	NAME OF PARTS	Q'TY
1	FRAME CURTAIN	2
2	SILL SUPPORT	2
3	BOLT	2
4	NUT	2
5	SCREW(TYPE A) (10mm(2/5"))	16
6	SCREW(TYPE B) D5.1mm(0.2")/16mm(0.63")	3
7	SCREW(TYPE C) D4.1mm(0.17")/16mm(0.63")	5
8	FOAM-STRIP	1
9	FOAM-PE (600mm x 25mm x 2mm)	1
10	WINDOW LOCKING BRACKET	1
11	FOAM-PE (920mm x 30mm x 2mm)	1
12	DRAIN PIPE	1
13	FRAME GUIDE	2

■ Top retainer bar is in the product package.

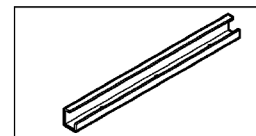

## Suggested Tool Requirements

**SCREWDRIVER (+, -), RULER, KNIFE, HAMMER, PENCIL, LEVEL**

### Preparation of Chassis

1. Remove the screws that fasten the cabinet at both sides and at the back.
2. Slide the unit out from the cabinet by gripping the base pan handle and pulling forward while bracing the cabinet.
3. Remove EPS Material.
4. Cut the window sash seal to the proper length. Peel off the backing and attach the foam-pe ⑨ to the underside of the window sash.
5. Remove the backing from the top upper guide Foam PE ⑪ and attach it to the bottom of the upper guide ⑩.
6. Attach the upper guide onto the top of the cabinet with 3 type A screws.
7. Insert the frame guides ⑫ into the bottom of the cabinet.
8. Insert the Frame Curtain ① into the upper guide ⑩ and frame guides ⑫.
9. Fasten the curtains to the unit with 4 Type A screws at the both sides.

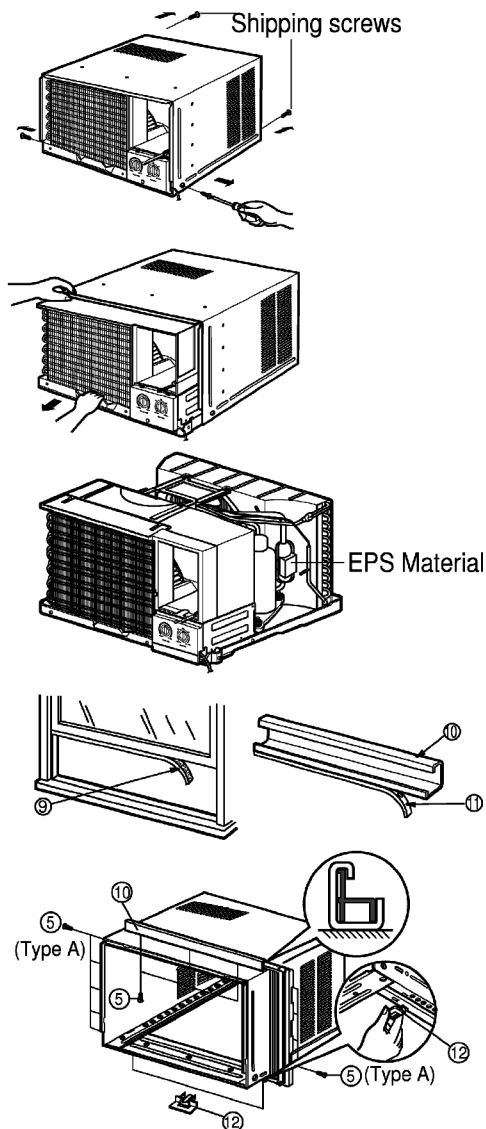

### Cabinet Installation

1. Open the window. Mark a line on center of the window stool (or desired air conditioner location). Carefully place the cabinet on the window stool and align the center mark on the bottom front with the center line marked in the window stool.
2. Pull the bottom window sash down behind the upper guide until it meets.

**NOTICE** Do not pull the window sash down so tightly that the movement of Frame Curtain is restricted.

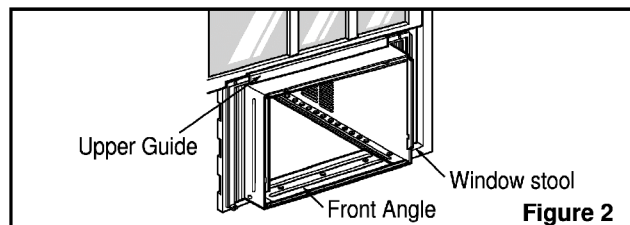

Figure 2

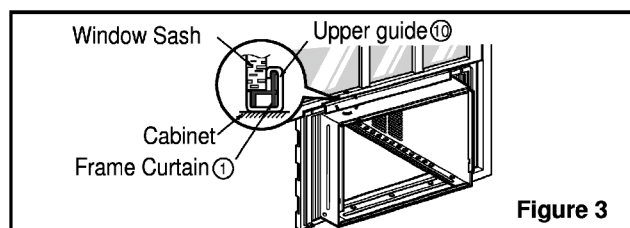
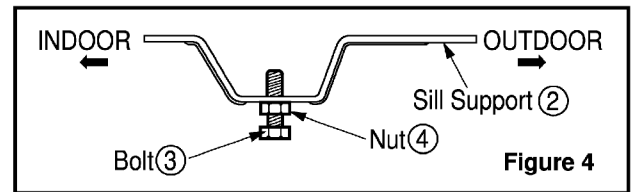

Figure 3

## Installation

3. Loosely assemble the sill support using the parts in Figure 4.



4. Select the position that will place the sill support near the outer most point on sill (See Figure 4)

**NOTICE** Be careful when you install the cabinet (Frame Guides 12 are broken easily).

5. Attach the sill support to the cabinet track hole in relation to the selected position using 2 Type A screws in each support (See Figure 5).

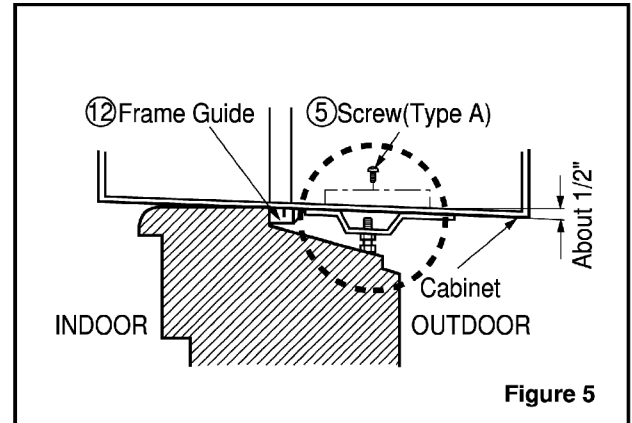

6. The cabinet should be installed with a very **slight tilt (about 1/2") downward** toward the outside (See Figure 6).  
Adjust the bolt and the nut of Sill Support for balancing the cabinet.

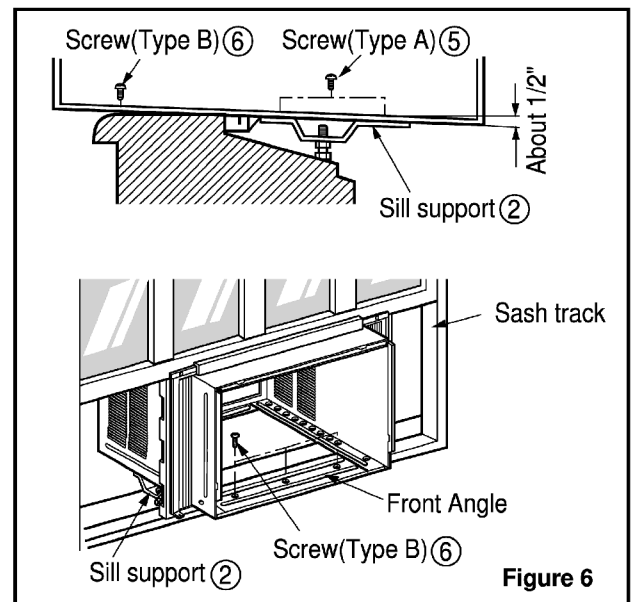

7. Attach the cabinet to the window stool by driving the screws ⑥ (Type B) through the front angle into window stool (5/8").
8. Pull each Frame Curtain properly to each window sash track, and repeat step 2.
9. Attach each Frame Curtain to the window sash by using screws ⑦ (Type C). (See Figure 7)

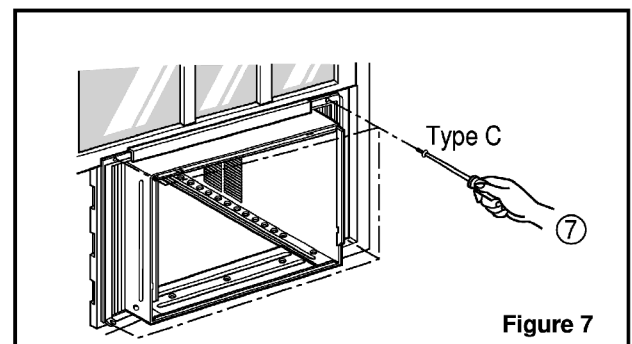

10. Slide the unit into the cabinet.(See Fig. 8)

**⚠ CAUTION: For security purpose, reinstall screws (Type A) at the cabinet's sides.**

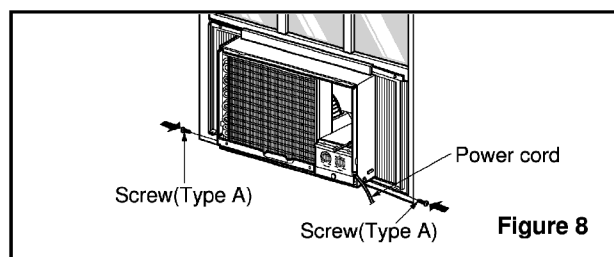

Figure 8

11. Cut the Foam-Strip ⑧ to the proper length and insert between the upper and lower window sash. (See Fig. 9)

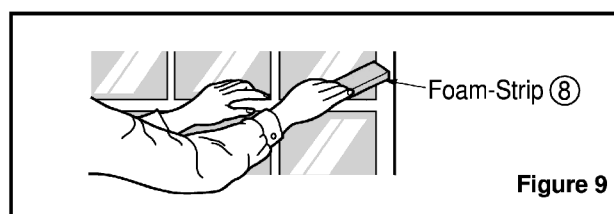

Figure 9

12. Attach the window Locking Bracket ⑬ with a type C screw. (See Fig. 10)

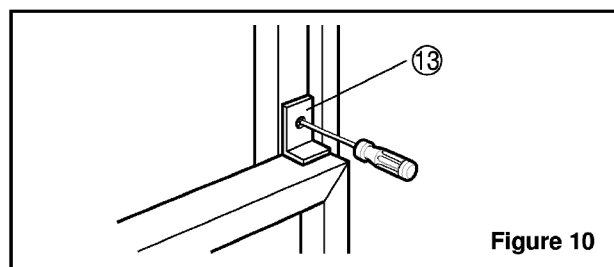

Figure 10

13. Attach the front grille to the cabinet by inserting the tabs on the grille into the tabs on the front of the cabinet. Push the grille in until it snaps into place. (See Fig. 11)

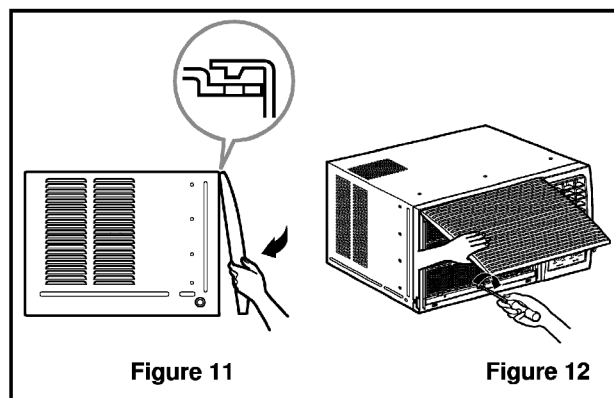

Figure 11

Figure 12

14. Lift the inlet grille and secure it with a type A screw through the front grille.(See Fig. 12)

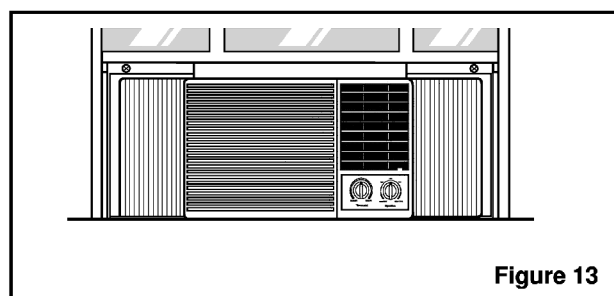

Figure 13

# Operation

## Features

- Designed for COOLING ONLY.
- Powerful and whispering cooling.
- Slide-in and slide-out chassis for the simple installation and service.
- Side air-intake, side cooled-air discharge.
- Built-in adjustable THERMOSTAT
- Washable one-touch filter
- Compact size
- Reliable and efficient rotary compressor

## Control Locations Function of Controls

### 1. Cooling Only Model

#### • VENTILATION

The ventilation lever must be in the CLOSE position in order to maintain the best cooling conditions.

When a fresh air is necessary in the room, set the ventilation lever OPEN position. The damper is opened and room air is exhausted.

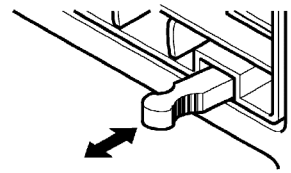

**CLOSE** **VENT** **OPEN**

#### • THERMOSTAT

Thermostat will automatically control the temperature of the room. Select a higher number for a cooler temperature in the room. The temperature is selected by positioning the knob to the desired position.

The 5 or 6 position is a normal setting for average conditions.

#### • OPERATION

- Off ( 0 ) : Turns the air conditioner off.
- MED FAN ( ⊕ ) : Permits the medium fan speed operation without cooling.
- LOW FAN ( ⊙ ) : Permits the low fan speed operation without cooling.
- HIGH COOL ( ✱ ) : Permits cooling with the high fan speed operation.
- MED COOL ( ✱ ) : Permits cooling with the medium fan speed operation.
- LOW COOL ( ✱ ) : Permits cooling with the low fan speed operation.

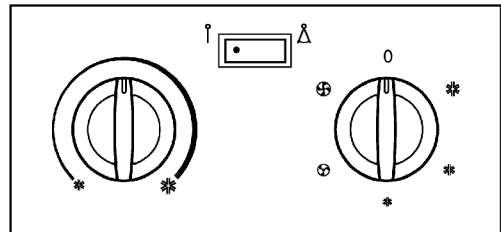
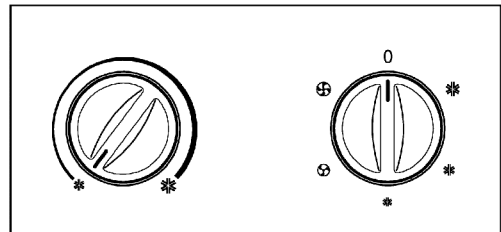
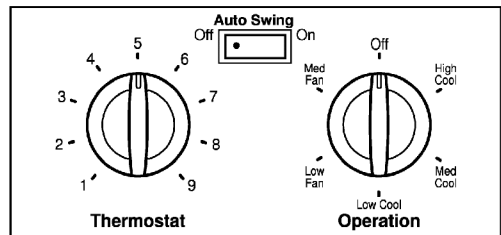
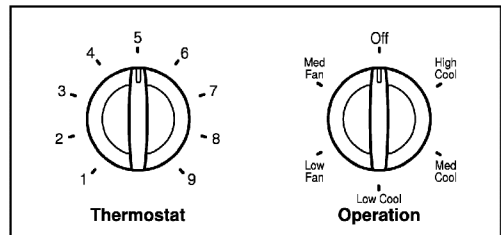

**CAUTION:** A slight heat odor may come from the unit when first switching to HEAT after the cooling season is over. This odor, caused by fine dust particles on the heater, will disappear quickly.

### 3. Cooling and Heating Model with Remote Control and Touch Type

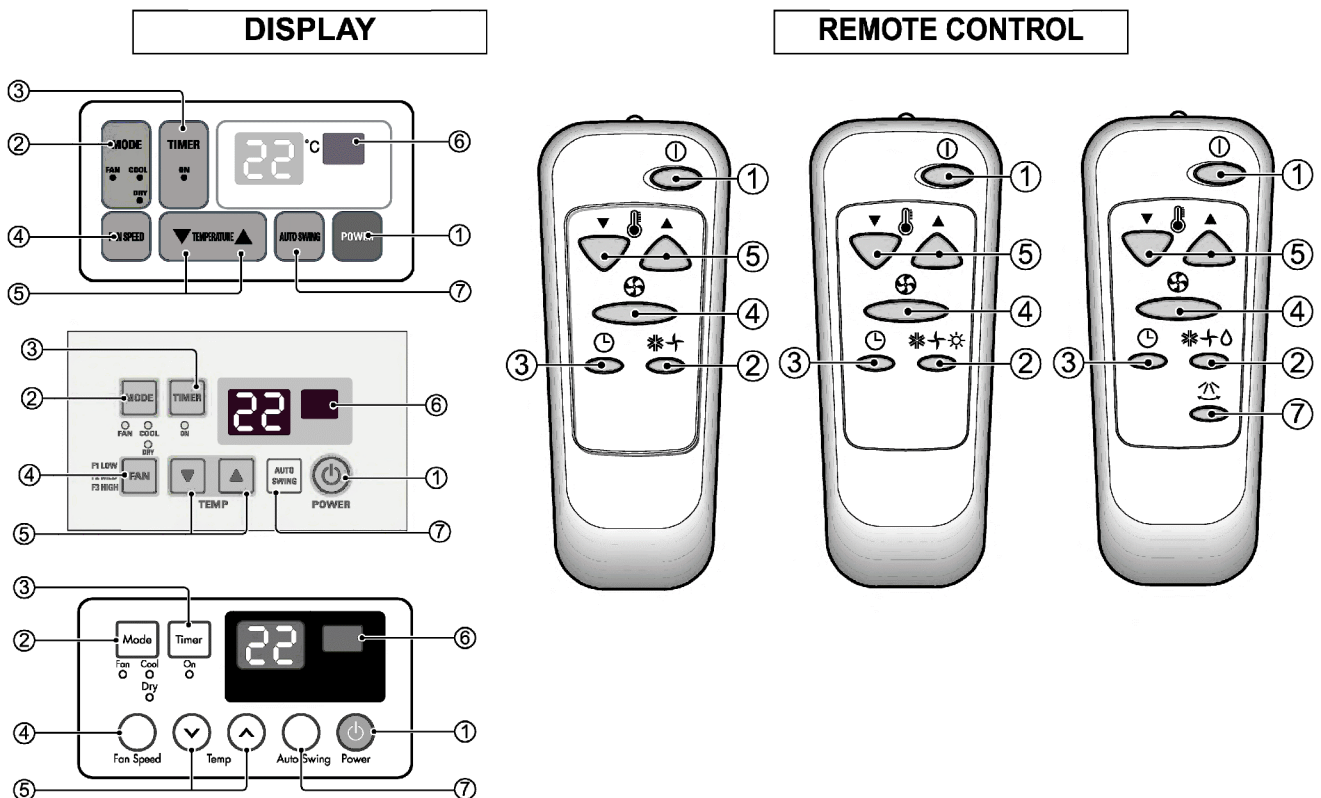

#### 1 POWER BUTTON

Operation starts, when this button is pressed and stops when you press the button again.

#### 2 OPERATION MODE SELECTION BUTTON

Select Cooling, Heating, or Fan mode with this button.

#### 3 ON/OFF TIMER BUTTON

Set the time of starting and stopping operation. The timer is set by 1 hour.

#### 4 FAN SPEED SELECTOR

Select the fan speed. Cooling Model: 3 steps {High[F3] → Low[F1] → Med[F2] → High[F3]... }  
 Heating Model: 2 steps {High [F2] → Low[F1] → High[F2]... }

#### 5 ROOM TEMPERATURE SETTING BUTTON

Control the room temperature within a range of 16°C to 30°C. The room temperature will be adjusted by 1°C 30min., and by 2°C 1 hour later.

#### 6 SIGNAL RECEIVER

#### 7 AUTO SWING

The vertical louver swings horizontally by the automatic system and stops when you press the button again.

# Disassembly

— Before the following disassembly, **CONTROL BOX** set to OFF and disconnect the power cord.

## Mechanical Parts

### 1. Front Grille

1. Open the Inlet grille upward .
2. Remove the screw that fastens the front grille.
3. Pull the front grille from the right side.
4. Remove the front grille.
5. Re-install the component by referring to the removal procedure, above.(See Figure 14)

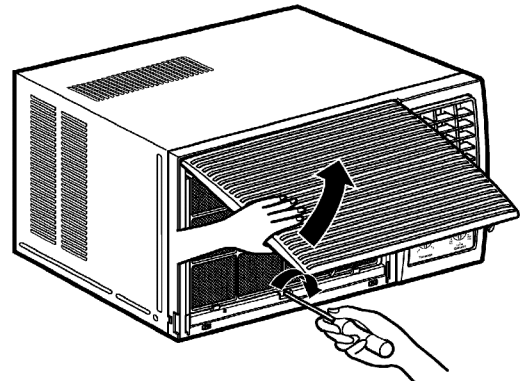

Figure 14

### 2. Cabinet

1. After disassembling the FRONT GRILLE, remove the 2 screws that fasten the cabinet at both sides.
2. Remove the 2 screws that fasten the cabinet at back.
3. Pull the base pan forward. (See Figure 15)
4. Remove the cabinet.
5. Re-install the component by referring to the removal procedure, above.

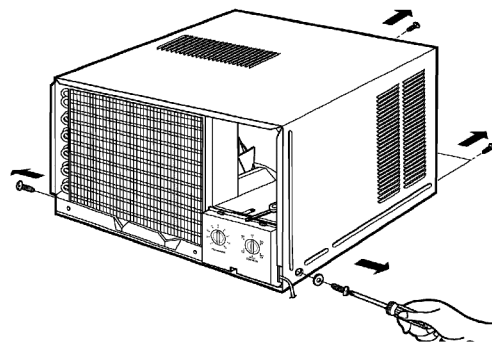

Figure 15

### 3. Control Box

1. Remove the front grille. (Refer to section 1)
2. Remove the cabinet. (Refer to section 2)
3. Remove the 2 screws that fasten the control box cover.
4. Remove two housings that connect compressor wire and motor wire in the control box.
5. Discharge the capacitor by placing a 20,000 ohm resistor across the capacitor terminals.
6. Remove the 2 screws that fasten the control box.
7. Pull the control box forward completely.
8. Re-install the components by referring to the removal procedure, above. (See Figure 16)  
(Refer to the circuit diagram found on page 23 in this manual and on the control box.)

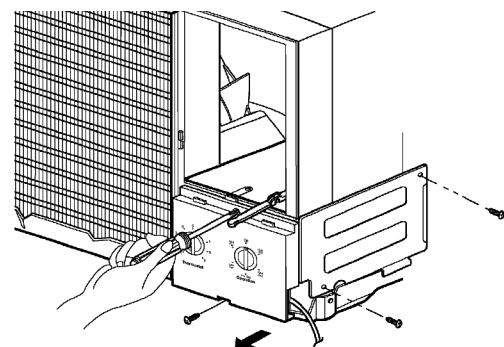

Figure 16

## Air Handling Parts

### 4. Air Guide and Turbo Fan

1. Remove the front grille. (Refer to section 1)
2. Remove the cabinet. (Refer to section 2)
3. Remove the control box. (Refer to section 3)
4. Remove the 4 screws that fasten the brace.
5. Remove the brace.
6. Remove the 2 screws that fasten the evaporator.
7. Move the evaporator forward and pulling it upward slightly. (See Figure 17)
8. Move the evaporator to the left carefully.
9. Pull out the hook of orifice by pushing the tabs and remove it. (See Figure 19)
10. Remove the clamp with a hand plier that secures the blower.
11. Remove the blower.
12. Remove the 4 screws that fasten the air guide from the barrier.
13. Move the air guide backward, pulling out from the base pan.
14. Re-install the components by referring to the removal procedure, above.

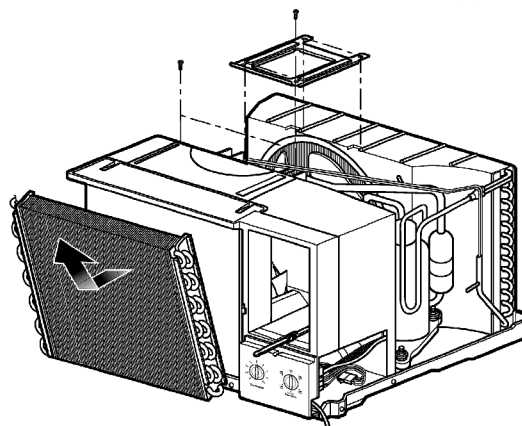

Figure 17

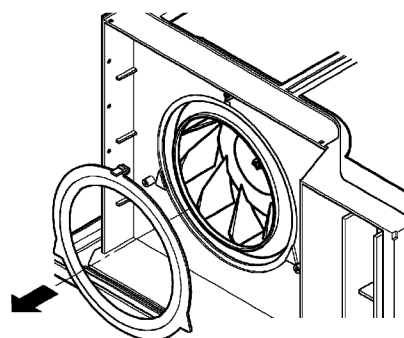

Figure 18

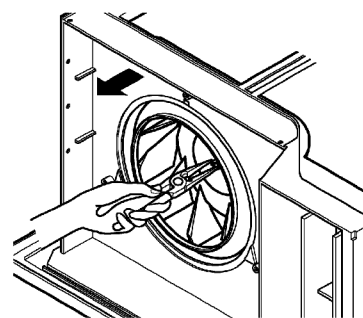

Figure 19

### 5. FAN

1. Remove the cabinet. (Refer to section 2)
2. Remove the brace (Refer to section 4)
3. Remove the 4 screws that fasten the condenser.
4. Move the condenser to the left carefully.
5. Remove the clamp that secures the fan.
6. Remove the fan. (See Figure 20)
7. Re-install by referring to the removal procedure.

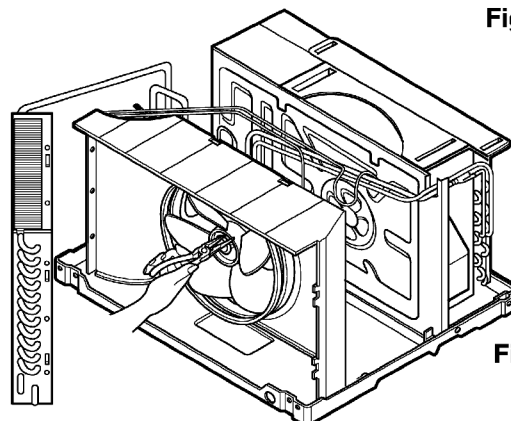

Figure 20

## 6. Shroud

1. Remove the fan. (Refer to section 5)
2. Remove the screw that fastens the shroud.
3. Remove the shroud. (See Figure 21)
4. Re-install the component by referring to the removal procedure, above.

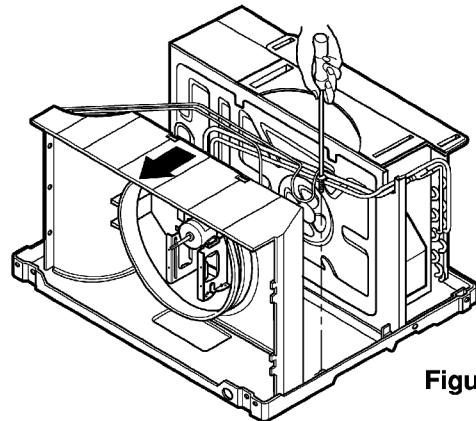

Figure 21

## Electrical Parts

### 7. Overload Protector

1. Remove the cabinet. (Refer to section 2)
2. Remove the nut that fastens the terminal cover.
3. Remove the terminal cover. (See Figure 22)
4. Remove all the leads from the overload protector.
5. Remove the overload protector.
6. Re-install the component by referring to the removal procedure, above.

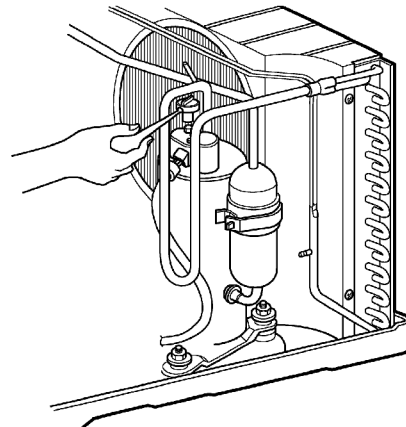

Figure 22

### 8. Compressor

1. Remove the cabinet. (Refer to section 2)
2. Discharge the refrigerant system using a Freon™ Recovery System. If there is no valve to attach the recovery system, install one (such as a Watco A-1) before venting the Freon™. Leave the valve in place after servicing the system.
3. Remove the overload protector. (Refer to section 7)
4. After purging the unit completely, unbrazed the suction and discharge tubes at the compressor connections.
5. Remove the 3 nuts and the 3 washers that fasten the compressor.
6. Remove the compressor. (See Figure 23)
7. Re-install the components by referring to the removal procedure, above.

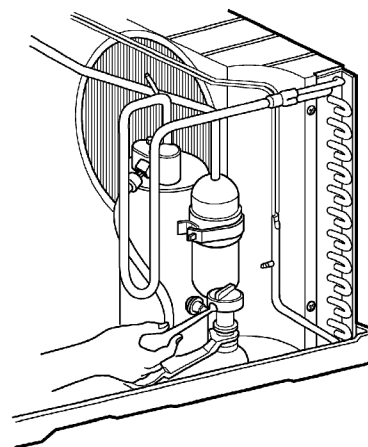

Figure 23

## 9. Capacitor

1. Remove the control box. (Refer to section 3)
2. Remove the knobs and the screw that fasten control panel from control box.
3. Remove the screw that located in the front.
4. Open the bottom side of control box.
5. Remove the screw and the clamp that fastens the capacitor.
6. Disconnect all the leads of capacitor terminals.
7. Re-install the components by referring to the removal procedure, above. (See Figure 24)

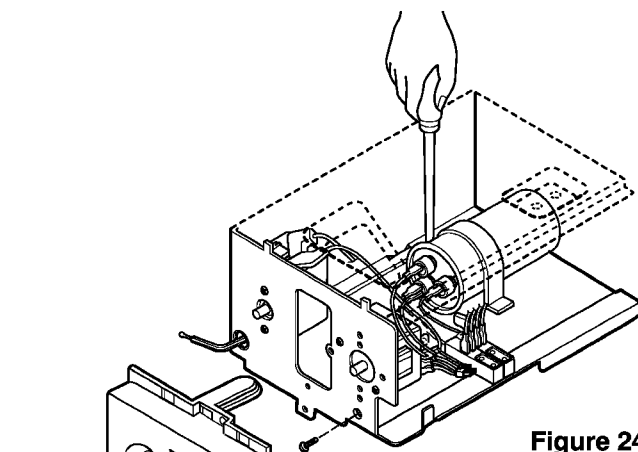

Figure 24

## 10. Power Cord

1. Remove the control box. (Refer to section 3)
2. Open the control box. (Refer to section 9)
3. Disconnect the grounding screw from the control box.
4. Disconnect the 2 receptacles.
5. Remove a screw which fastens the clip cord. (See Figure 25)
6. Remove the power cord.
7. Re-install the component by referring to the above removal procedure, above. (Use only one ground-marked hole  $\oplus$  for ground connection.)
8. If the supply cord of this appliance is damaged, it must be replaced by the special cord. (The special cord means the cord that has the same specification marked on the supply cord attached at the unit.)

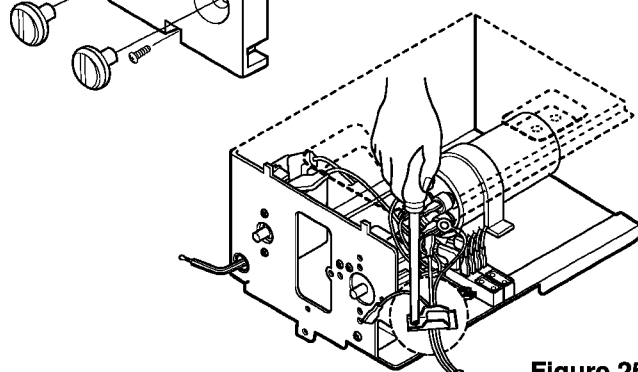

Figure 25

## 11. Thermostat

1. Remove the control box. (Refer to section 3)
2. Open the control box. (Refer to section 9)
3. Remove the 2 screws that fasten the thermostat.
4. Disconnect 2 leads of thermostat terminals.
5. Remove the thermostat.
6. Re-install the components by referring to the above removal procedure. (See Figure 26)

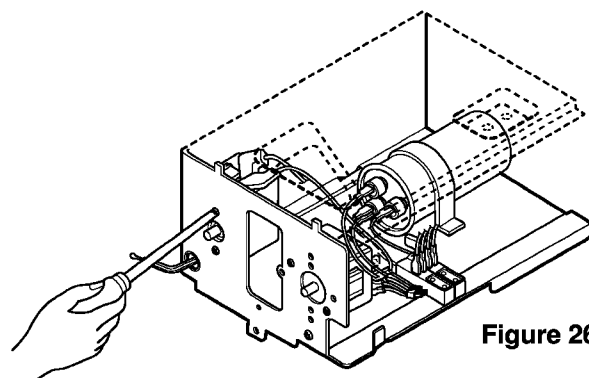

Figure 26

## 12. Rotary Switch

1. Remove the control box. (Refer to section 3)
2. Open the control box. (Refer to section 9)
3. Remove the 2 screws that fasten the rotary switch.
4. Disconnect all the leads of the rotary switch terminals.
5. Remove the rotary switch.
6. Re-install the components by referring to the above removal procedure. (See Figure 27)

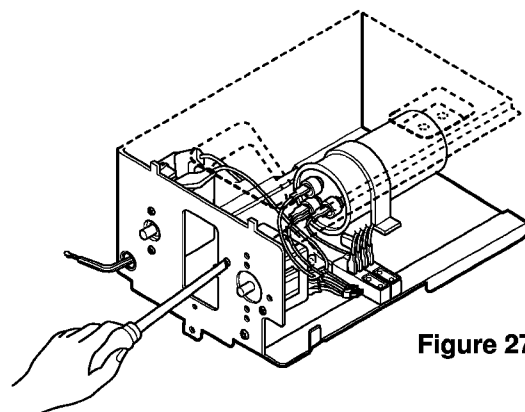

Figure 27

### 13. Motor

1. Remove the cabinet. (Refer to section 2)
2. Remove the evaporator. (Refer to section 4)
3. Remove the orifice. (Refer to section 4)
4. Remove the blower. (Refer to section 4)
5. Remove the fan. (Refer to section 5)
6. Remove the control box cover and disconnect 5 or 4 wires of motor housing. (Refer to section 3)
7. Remove the 2 or 4 screws that fasten the motor from the mount motor. (See Figure 28)
8. Remove the motor.
9. Re-install the components by referring to the removal procedure, above.(See Figure 28)

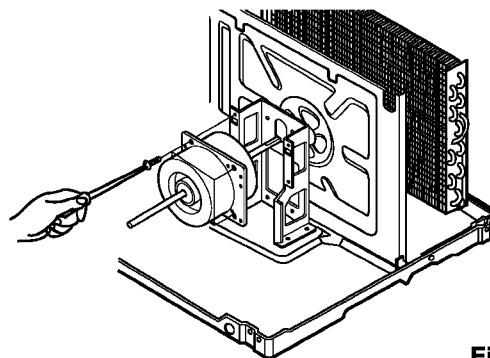

Figure 28

### 14. Reversing Valve Assy(heating Model)

1. Remove the cabinet. (Refer to section 2)
2. Remove the reversing coil from the reversing valve assembly by loosening the screw.
3. Discharge the refrigerant system using a Freon™ recovery system.  
If there is no valve to attach the recovery system, install one (such as a WATCO A-1) before venting the Freon™.  
Leave the valve in place after servicing.
4. After discharging the refrigerant completely, unbraid the interconnecting tube at the reversing valve assembly connections.
5. Re-install the components by referring to the removal procedure, above.

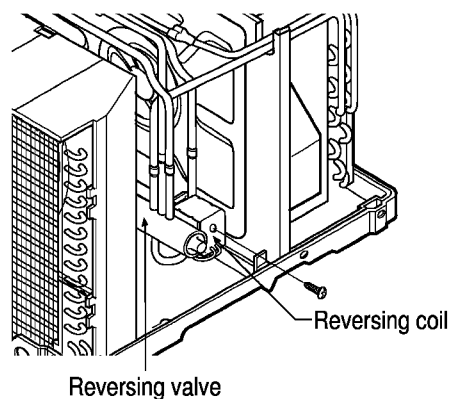

Figure 29

#### **NOTICE**

When connect the reversing valve assembly, braze the reversing valve and inter-connecting tube immersing in water not to make the temperature of surface exceed more than 120°C(248°F)

## Refrigerating Cycle

**⚠ CAUTION: Discharge the refrigerant system using a Freon™ Recovery System. If there is no valve to attach the recovery system, install one (such as a WATCO A-1) before venting the Freon™. Leave the valve in place after servicing the system.**

### 15. Condenser

1. Remove the cabinet. (Refer to section 2)
2. Remove the 4 screws that fasten the brace. (Refer to section 4)
3. Remove the 5 screws that fasten the condenser and shroud.
4. After discharging the refrigerant completely, unbraid the interconnecting tube at the condenser connections.
5. Remove the condenser.
6. Re-install the component by referring to notes. (See Figure 30)

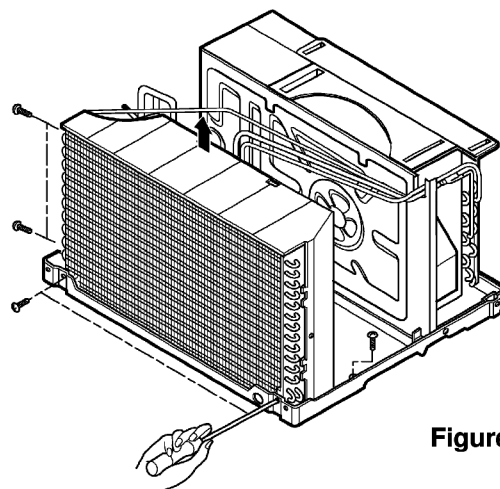

Figure 30

### 16. evaporator

1. Remove the cabinet. (Refer to section 2)
2. Remove the 2 screws that fasten the evaporator.
3. Move the evaporator sideways carefully. (Refer to section 4)
4. After discharging the refrigerant completely, unbraid the interconnecting tube at the evaporator connections.
5. Remove the evaporator.
6. Re-install the component by referring to notes. (See Figure 31)

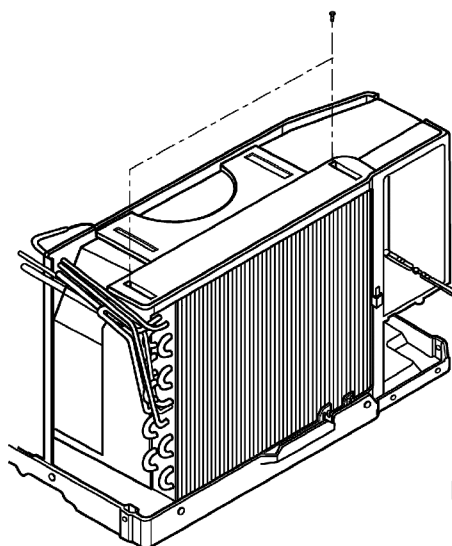

Figure 31

## 17. Capillary Tube

1. Remove the cabinet. (Refer to section 2)
2. After discharging the refrigerant completely, unbraid the interconnecting tube at the capillary tube. (See caution above)

### NOTICE

— Replacement of the refrigeration cycle.

1. When replacing the refrigeration cycle, be sure to discharge the refrigerant system using a Freon™ recovery System.  
If there is no valve to attach the recovery system, install one (such as a WATCO A-1) before venting the Freon™. Leave the valve in place after servicing the system.
2. After discharging the unit completely, remove the desired component, and unbraid the pinch-off tubes.
3. Solder service valves into the pinch-off tube ports, leaving the valves open.
4. Solder the pinch-off tubes with Service valves.
5. Evacuate as follows.
  - 1) Connect the vacuum pump, as illustrated figure 32A.
  - 2) Start the vacuum pump, slowly open manifold valves A and B with two full turns counterclockwise and leave the valves open.  
The vacuum pump is now pulling through valves A and B up to valve C by means of the manifold and entire system.

 **CAUTION: If high vacuum equipment is used, just crack valves A and B for a few minutes, then open slowly with the two full turns counterclockwise. This will keep oil from foaming and being drawn into the vacuum pump.**

- 3) Operate the vacuum pump vacuum for 20 to 30 minutes, until 600 microns of vacuum is obtained. Close valves A and B, and observe vacuum gauge for a few minutes. A rise in pressure would indicate a possible leak or moisture remaining in the system. With valves A and B closed, stop the vacuum pump.
- 4) Remove the hose from the vacuum pump and place it on the charging cylinder. See figure 32B. Open valve C.  
Discharge the line at the manifold connection.
- 5) The system is now ready for final charging.

3. Remove the capillary tube.
4. Re-install the component by referring to notes.

6. Recharge as follows :
  - 1) Refrigeration cycle systems are charged from the High-side. If the total charge cannot be put in the High-side, the balance will be put in the suction line through the access valve which you installed as the system was opened.
  - 2) Connect the charging cylinder as shown in figure 32B.  
With valve C open, discharge the hose at the manifold connection.
  - 3) Open valve A and allow the proper charge to enter the system. Valve B is still closed.
  - 4) If more charge is required, the high-side will not take it. Close valve A.
  - 5) With the unit running, open valve B and add the balance of the charge.
    - a. Do not add the liquid refrigerant to the Low-side.
    - b. Watch the Low-side gauge; allow pressure to rise to 30 lbs.
    - c. Turn off valve B and allow pressure to drop.
    - d. Repeat steps b. and c. until the balance of the charge is in the system.
  - 6) When satisfied the unit is operating correctly, use the pinch-off tool with the unit still running and clamp on to the pinch-off tube. Using a tube cutter, cut the pinch-off tube about 2 inches from the pinch-off tool. Use sil-fos braze and braze pinch-off tube closed. Turn off the unit, allow it to set for a while, and then test the leakage of the pinch-off connection.

**Equipment needed:** Vacuum pump, Charging cylinder, Manifold gauge, Brazing equipment. Pin-off tool capable of making a leak-proof seal, Leak detector, Tubing cutter, Hand Tools to remove components, Service valve.

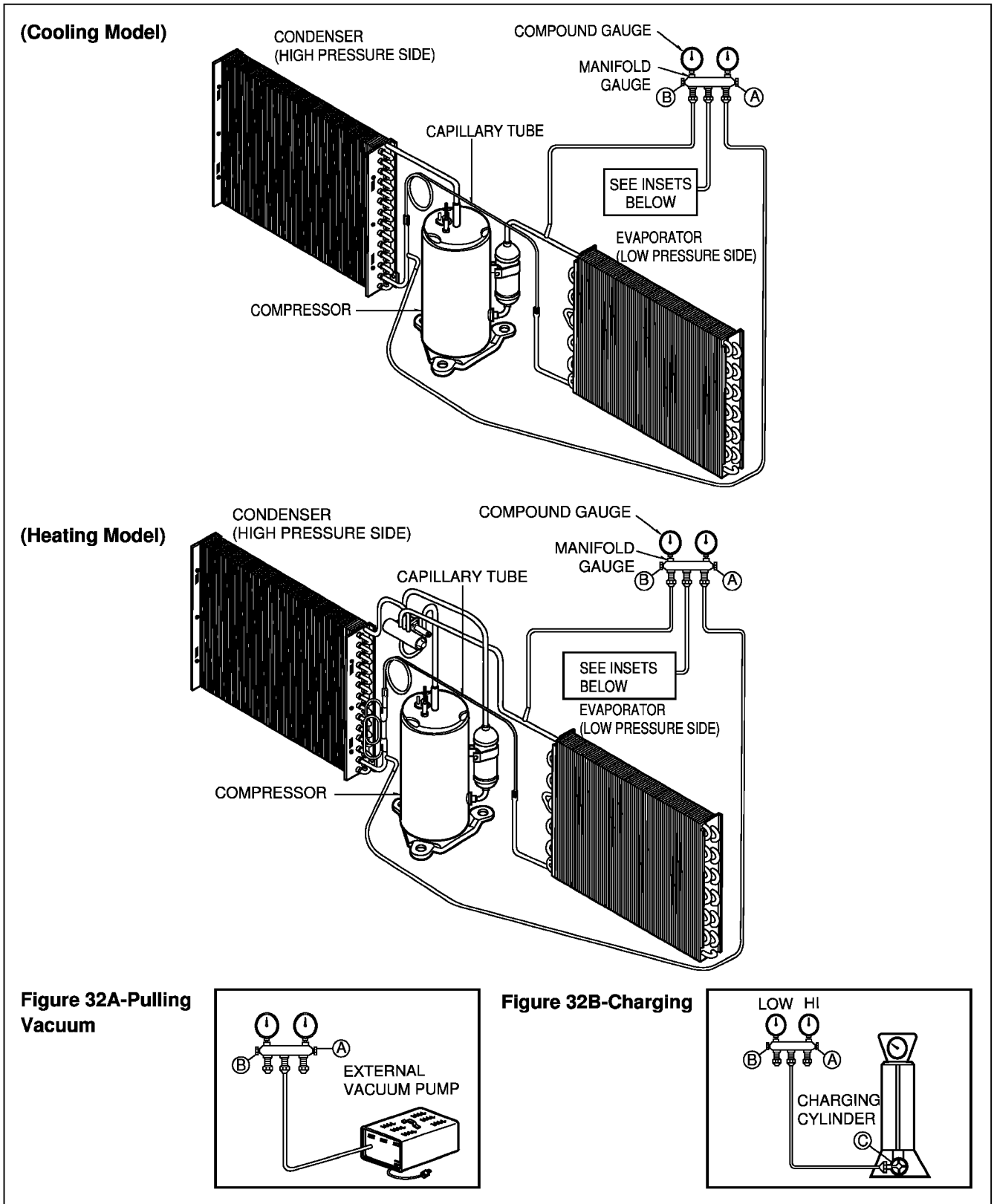

# Troubleshooting Guide

## Piping System

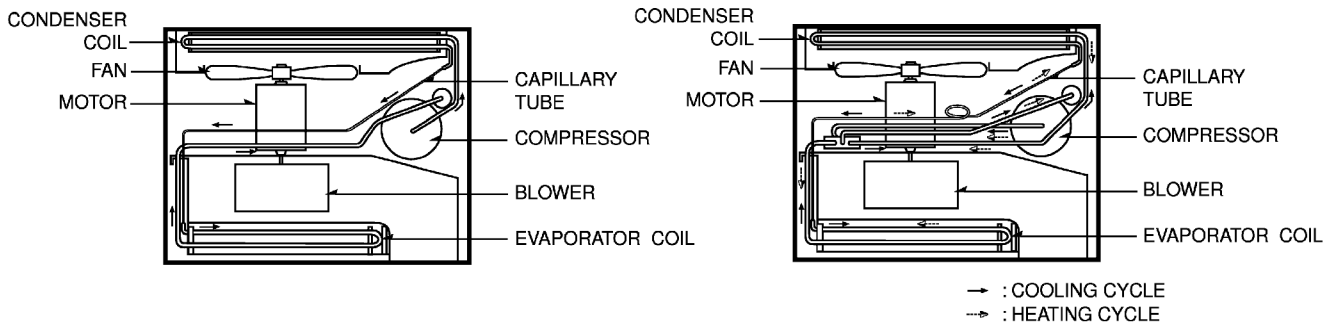
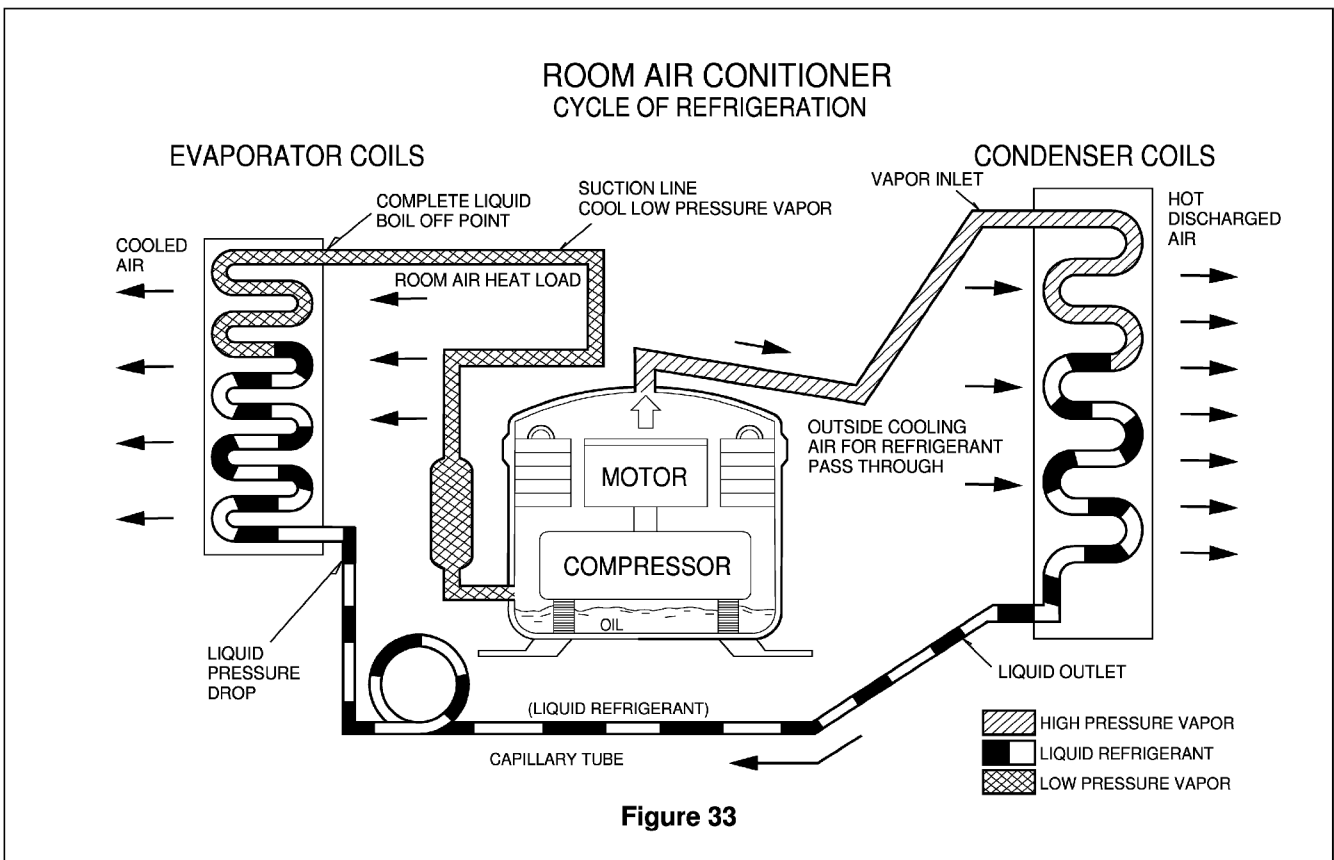

Figure 32 is a brief description of the important components and their function in what is called the refrigeration system. This will help you to understand the refrigeration cycle and the flow of the refrigerant in the cooling cycle.



## Troubleshooting Guide

In general, possible trouble is classified in two kinds.

The one is called Starting Failure which is caused from an electrical defect, and the other is ineffective Air Conditioning caused by a defect in the refrigeration circuit and improper application.

### Unit runs but poor cooling.

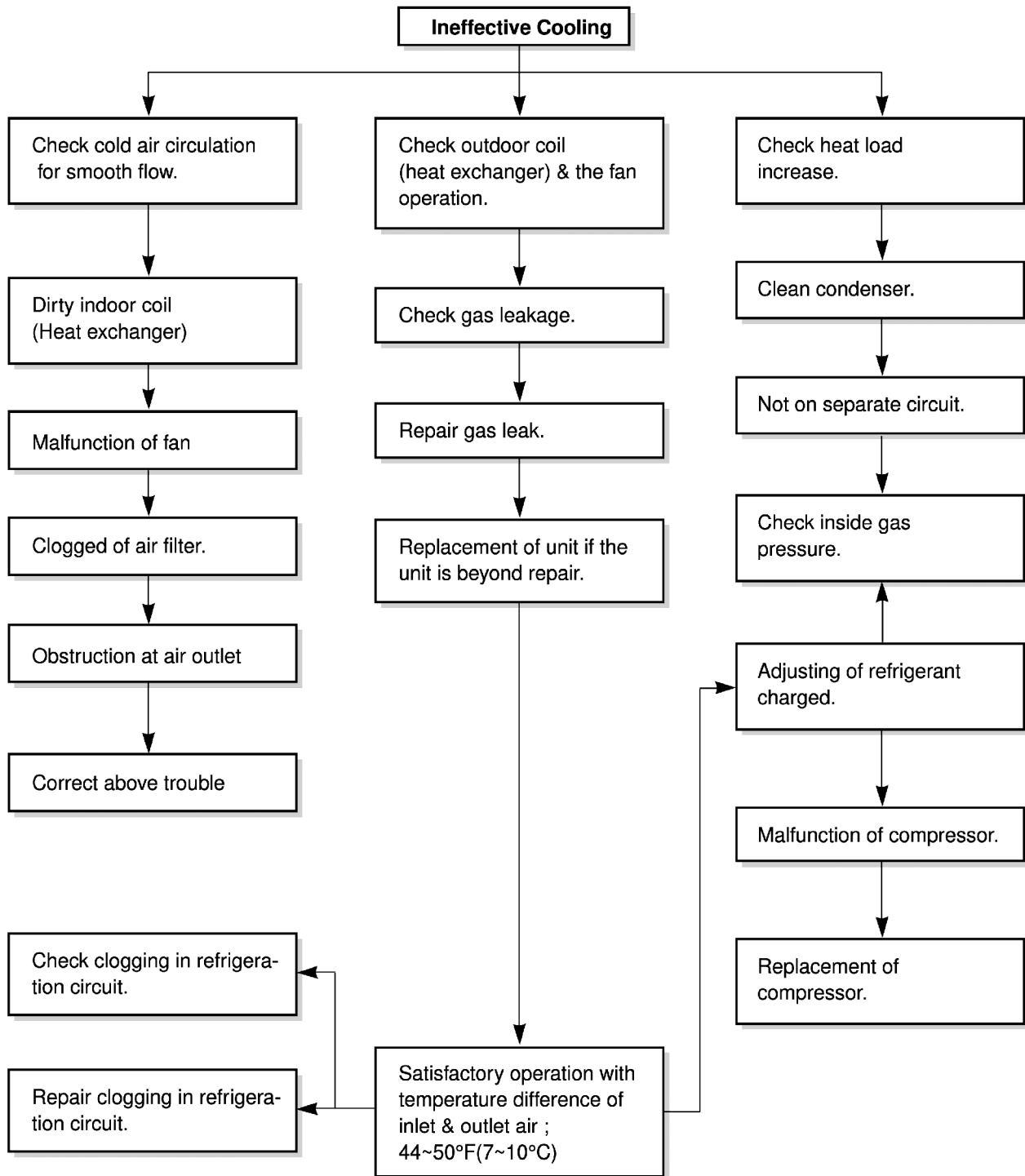

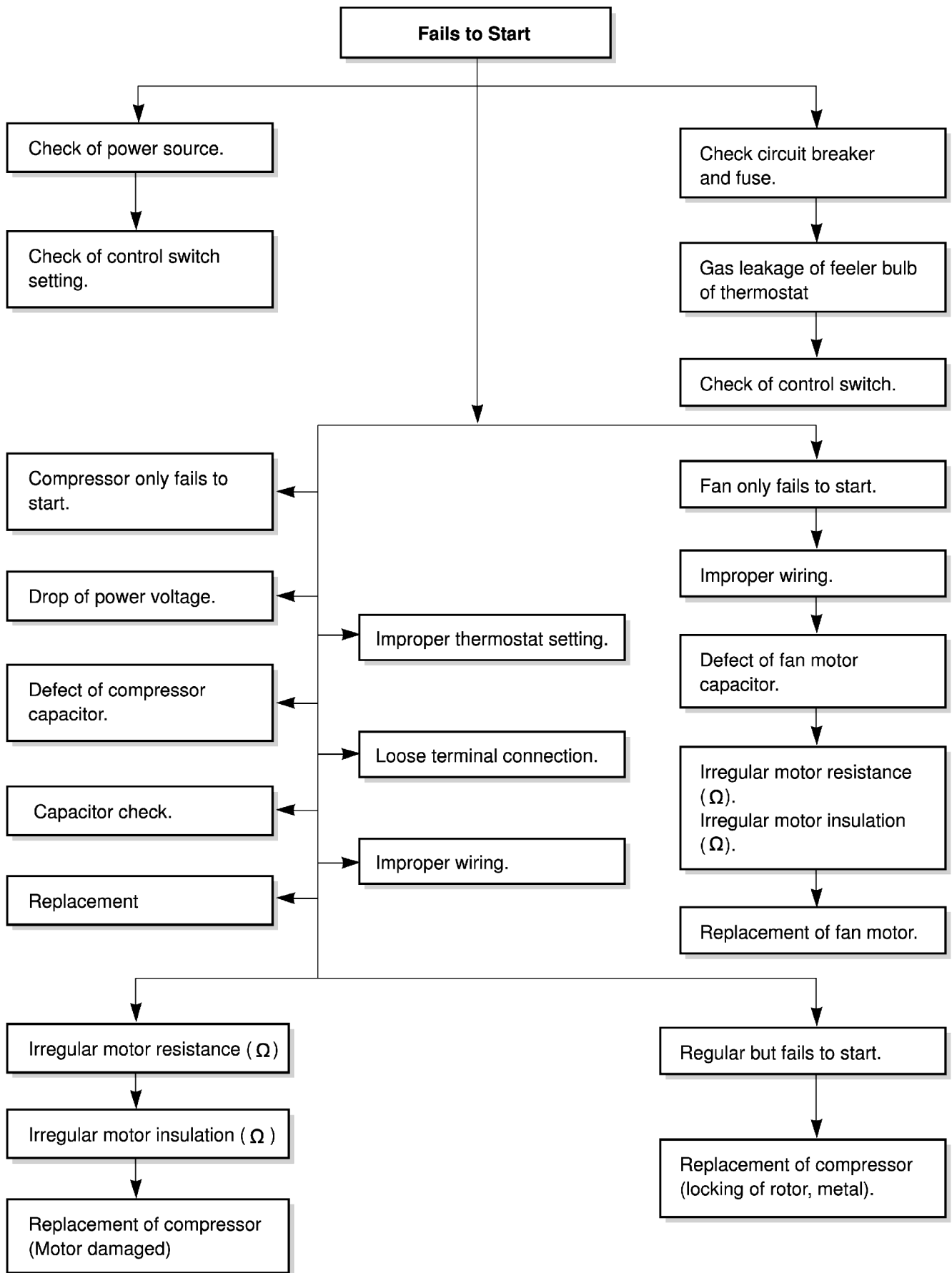

**Electrical Parts Troubleshooting Guide**

**TWC123CBMM0, TWC126CBMM0/CBMM1/CEMM0/CSMM0**

**Possible Trouble 1**

The unit does not operate.

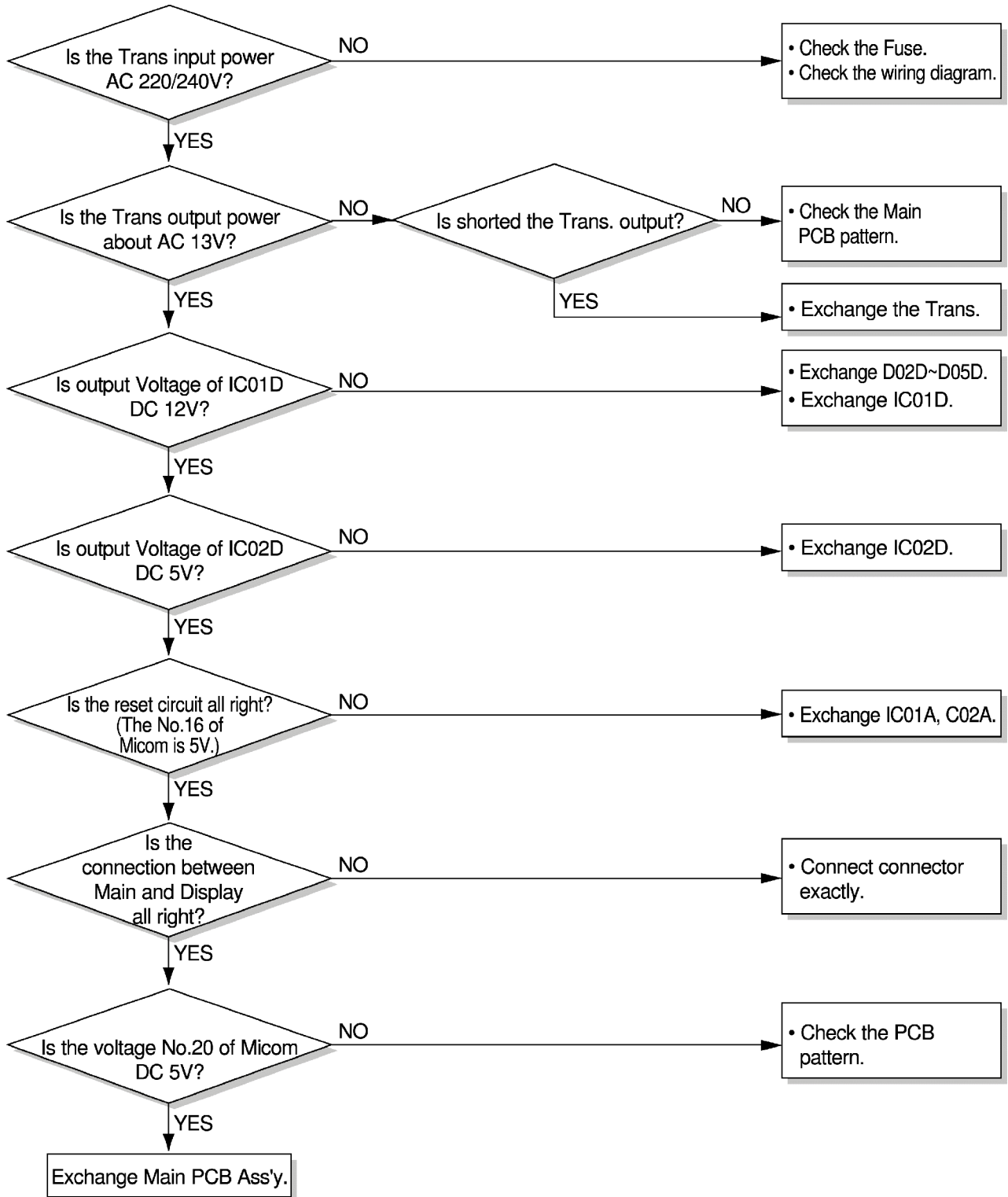

**Possible Trouble 2**

The compressor does not operate.

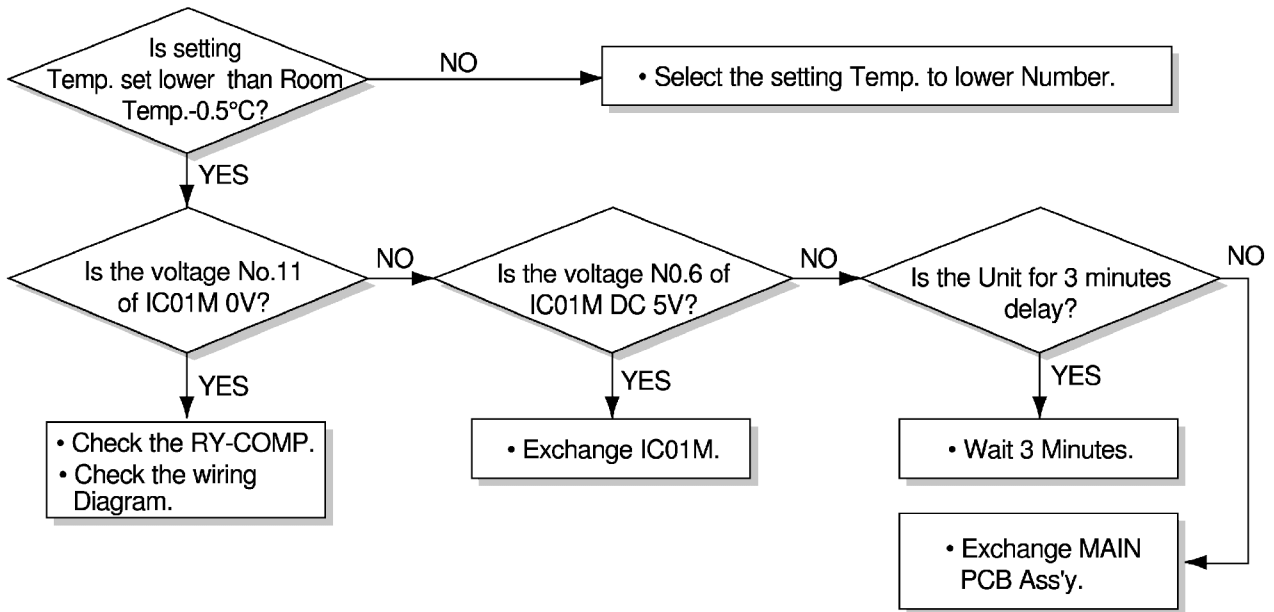

**Possible Trouble 3**

The compressor always operate.

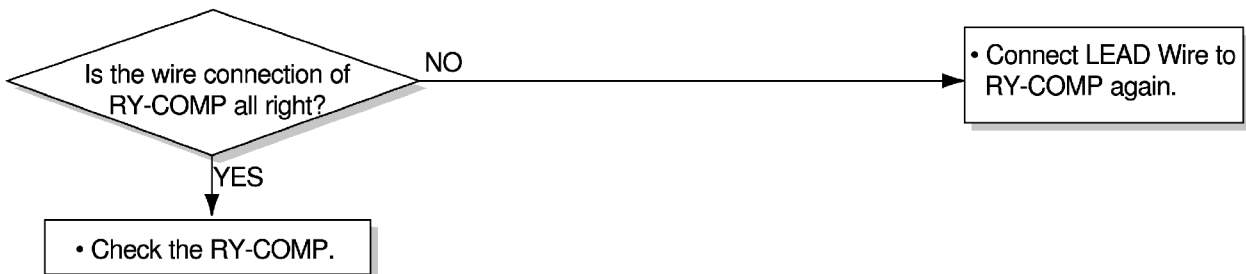

**Possible Trouble 4**

FAN does not operate.

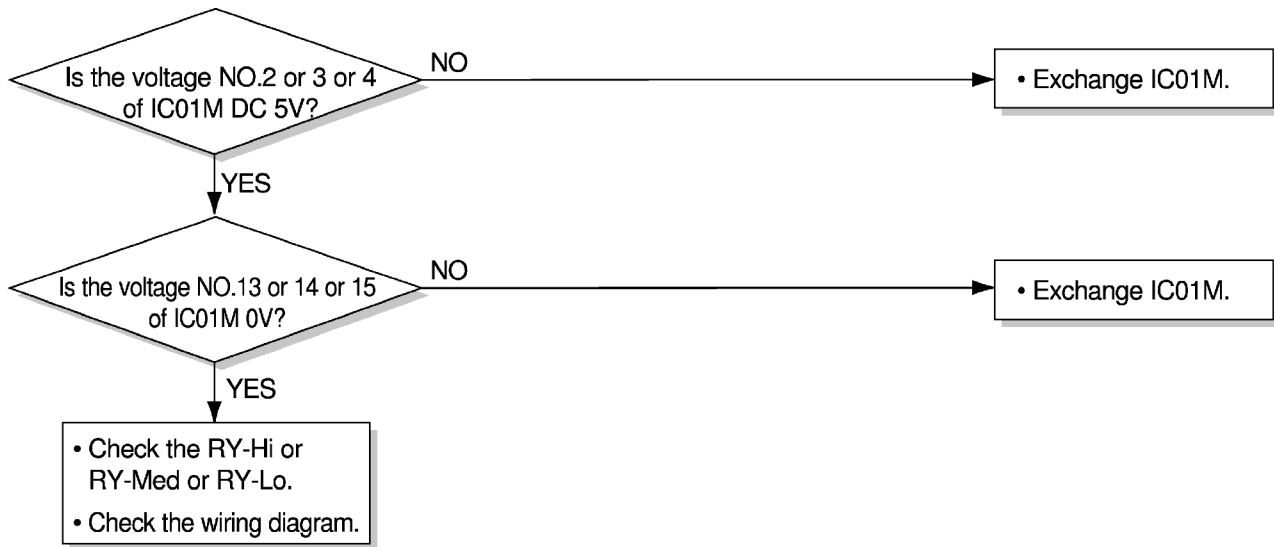

**Possible Trouble 5**

The function of Energy Saver does not operate.

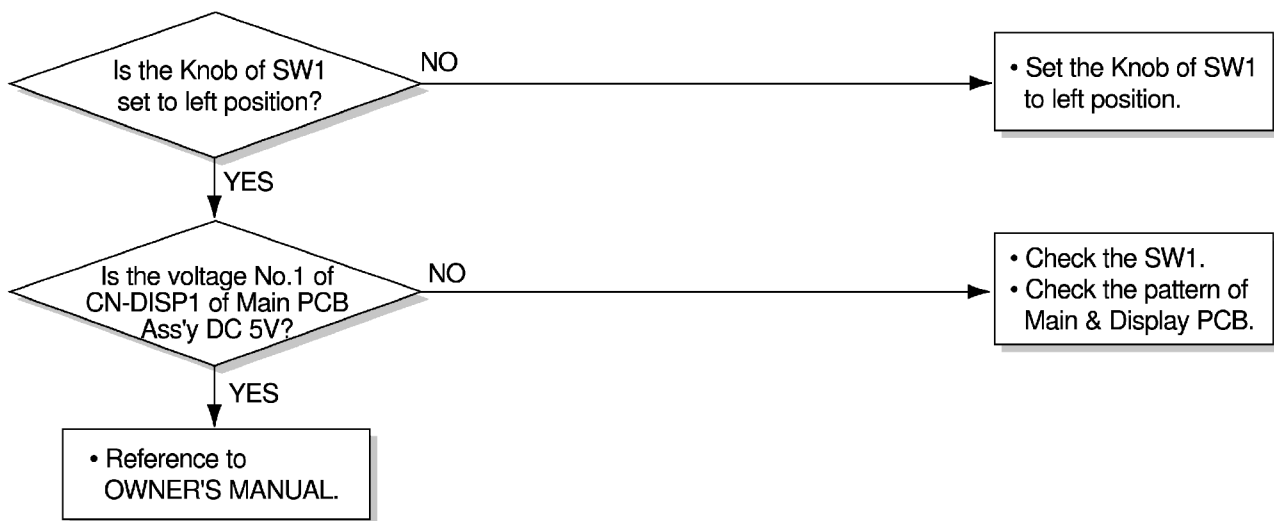

**Possible Trouble 6**

Remote controller does not operate.

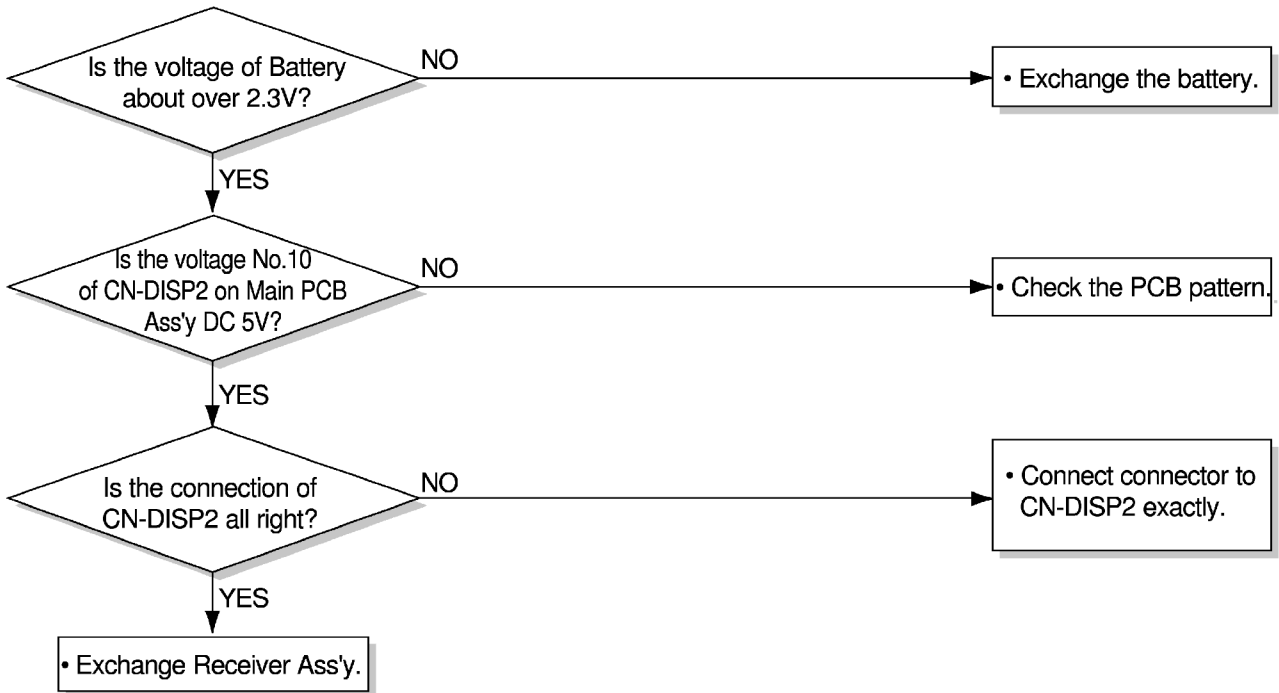

**Possible Trouble 7**

It displays abnormally on display PCB Ass'y.

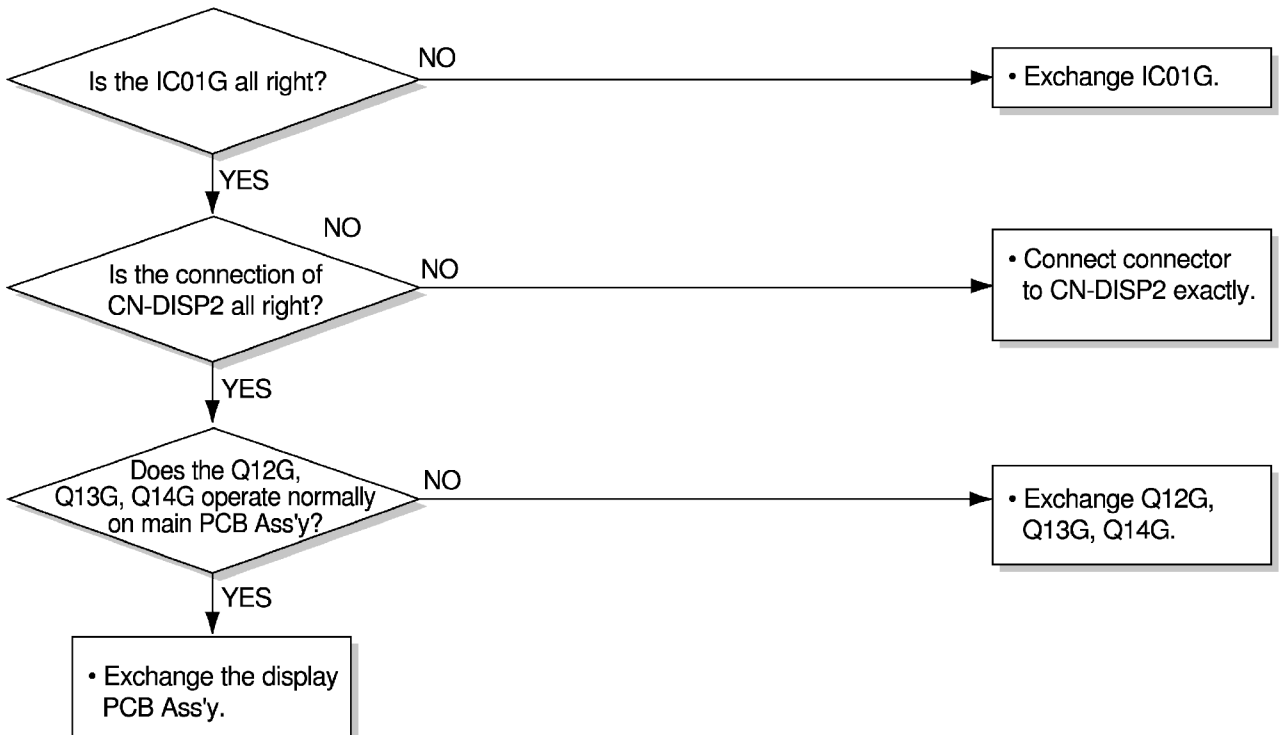

## Room Air Conditioner Voltage Limits

NAME PLATE RATING	MINIMUM	MAXIMUM
220~240±10%	198V	264V

COMPLAINT	CAUSE	REMEDY
Fan motor will not run.	No power	Check voltage at outlet. Correct if necessary.
	Power supply cord	Check voltage to rotary switch. If none, check power supply cord. Replace cord if circuit is open.
	Rotary switch	Check switch continuity. Refer to wiring diagram for terminal identification. Replace switch if defective.
	Wire disconnected or connection loose	Connect wire. Refer to wiring diagram for terminal identification. Repair or replace loose terminal.
	Capacitor (Discharge capacitor before testing.)	Test capacitor. Replace if not within ±10% of manufacturer's rating. Replace if shorted, open, or damaged.
	Will not rotate	Fan blade hitting shroud or blower wheel hitting scroll. Realign assembly.  Units using slinger ring for condenser fan must have $\frac{1}{4}$ to $\frac{5}{16}$ inch clearance to the base. If it hits the base, shim up the bottom of the fan motor with mounting screw(s).  Check fan motor bearings; if motor shaft will not rotate, replace the motor.
Fan motor runs intermittently	Revolves on overload.	Check voltage. If not within limits, call an electrician.  Test capacitor. Check bearings. Does the fan blade rotate freely? If not, replace fan motor.  Pay attention to any change from high speed to low speed. If the speed does not change, replace the motor.
Fan motor noise.	Fan	If cracked, out of balance, or partially missing, replace it.
	Turbo	If cracked, out of balance, or partially missing, replace it.
	Loose clamper	Tighten it.
	Worn bearings	If knocking sounds continue when running or loose, replace the motor. If the motor hums or noise appears to be internal while running, replace motor.
Compressor will not run, but fan motor runs.	Voltage	Check voltage. If not within limits, call an electrician.
	Wiring	Check the wire connections, if loose, repair or replace the terminal. If wires are off, refer to wiring diagram for identification, and replace. Check wire locations. If not per wiring diagram, correct.
	Rotary	Check for continuity, refer to the wiring diagram for terminal identification. Replace the switch if circuit is open.

COMPLAINT	CAUSE	REMEDY
Compressor will not run, but fan motor runs.	Thermostat	Check the position of knob. If not at the coldest setting, advance the knob to this setting and restart unit. Check continuity of the thermostat. Replace thermostat if circuit is open.
	Thermistor	Check the TEMP control. If not at the lowest number, set TEMP control to this setting and restart the unit. Check the continuity of the thermistor. Replace the thermistor if the circuit is open.
	Capacitor (Discharge capacitor before servicing.)	Check the capacitor. Replace if not within $\pm 10\%$ of manufacturer's rating. Replace if shorted, open, or damaged.
	Compressor	Check the compressor for open circuit or ground. If open or grounded, replace the compressor.
	Overload	Check the compressor overload, if externally mounted. Replace if open. (If the compressor temperature is high, remove the overload, cool it, and retest.)
Compressor cycles on overload.	Voltage	Check the voltage. If not within limits, call an electrician.
	Overload	Check overload, if externally mounted. Replace if open. (If the compressor temperature is high, remove the overload, cool, and retest.)
Compressor cycles on overload.	Fan motor	If not running, determine the cause. Replace if required.
	Condenser air flow restriction	Remove the cabinet. Inspect the interior surface of the condenser; if restricted, clean carefully with a vacuum cleaner (do not damage fins) or brush. Clean the interior base before reassembling.
	Condenser fins (damaged)	If condenser fins are closed over a large area on the coil surface, head pressures will increase, causing the compressor to overload. Straighten the fins or replace the coil.
Compressor cycles on overload.	Capacitor	Test capacitor.
	Wiring	Check the terminals. If loose, repair or replace.
	Refrigerating system	Check the system for a restriction.
Insufficient cooling or heating	Air filter	If restricted, clean or replace.
	Exhaust damper door	Close if open.
	Unit undersized	Determine if the unit is properly sized for the area to be cooled.
Excessive noise	Turbo or fan	Check the set screw or clamp. If loose or missing, correct. If the turbo or fan is hitting air guide, rearrange the air handling parts.
	Copper tubing	Remove the cabinet carefully and rearrange tubing not to contact cabinet, compressor, shroud, and barrier.

# Schematic Diagram

## Electronic Control Device

- MODEL : TWC123CBMM0 , TWC126CBMM0/CBMM1/CEMM0/CSMM0

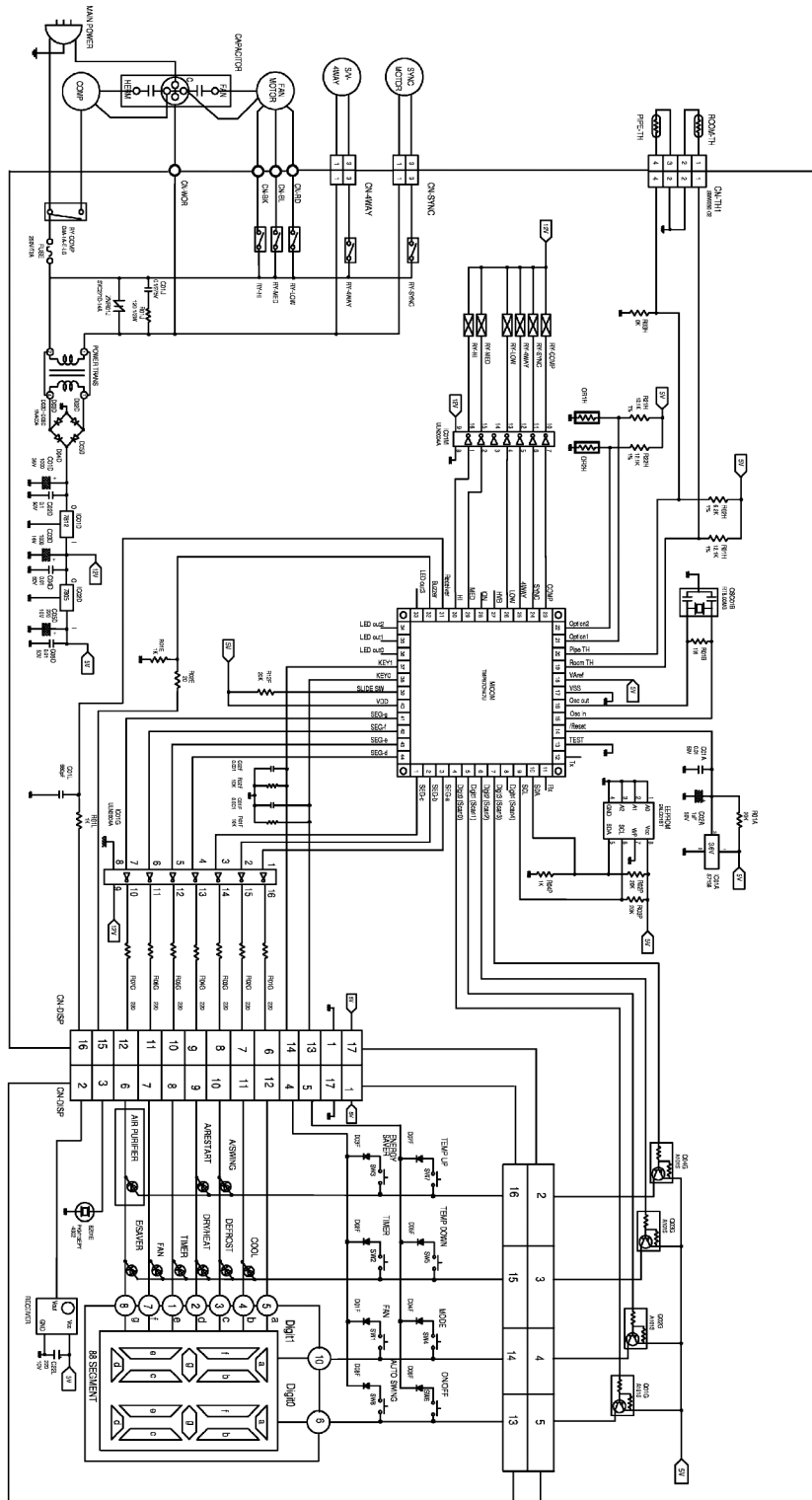

Schematic Diagram

• MODEL : TWC123CBAD0

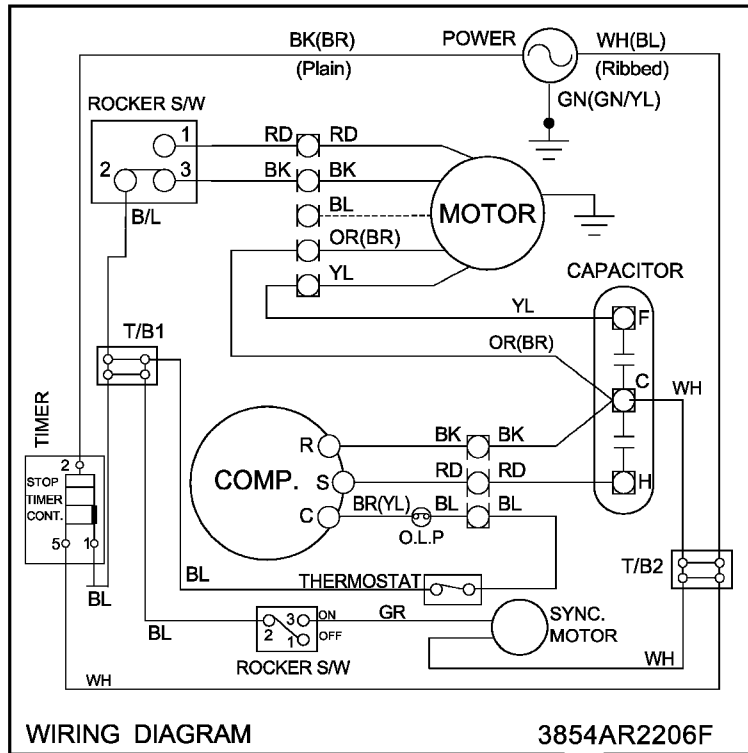

NO.	DESCRIPTION	PART NO.	QTY PER SET
		TWC123CBAD0	
1	POWER CORD	2H00677G	1
2	ROTARY SWITCH	2H00598F	1
3	FAN MOTOR	4681A20073D	1
4	CAPACITOR	6120AR2194C	1
5	THERMOSTAT	2H01109L	1
6	OVERLOAD PROTECTOR	6750U-L058A	1
7	COMPRESSOR	2520UCBK016	1
8	SYNC. MOTOR	2H01102J	1
9	ROCKER SWITCH	2H01316C	1

• MODEL :TWC126CBAB0\CBAB1\CEAB0\CNAB1\CSAB0

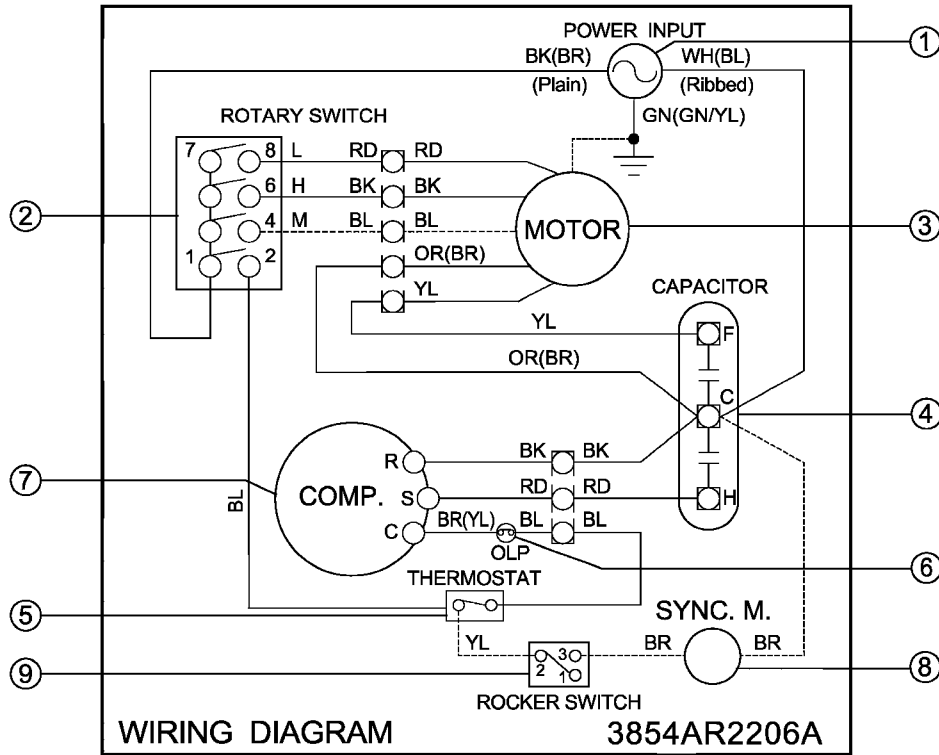

NO.	DESCRIPTION	PART NO.			Q'TY PER SET
		TWC126CBAB0	TWC126CBAB1	TWC126CNAB1/CEAB0/CSAB0	
1	POWER CORD	3H03555A	3H01652N		1
2	CAPACITOR	6120AR2194C	6120AR2194A	6120AR2194C	1
3	FAN MOTOR	4681A20174A			1
4	ROTARY SWITCH	2H00598F			1
5	THERMOSTAT	2H01109L			1
6	OVERLOAD PROTECTOR	6750U-L058A			1
7	COMPRESSOR	2520UCBJ003			1
8	SYNC. MOTOR	2H01102J			1
9	ROCKER SWITCH	2H01316C			1

## Schematic Diagram

• MODEL : TWC123CBMM0 , TWC126CBMM0/CBMM1/TWC126CSMM0/TWC126CEMM0

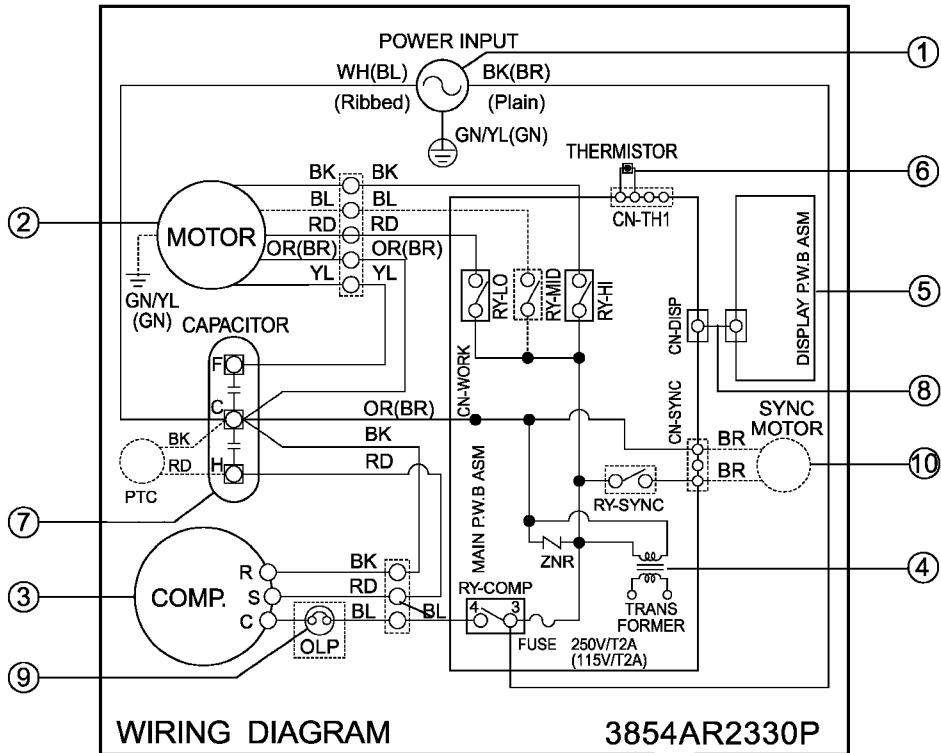

NO.	DESCRIPTION	PART NO.			QTY PER SET
		TWC123CBMM0	TWC126CBMM0	TWC126CBMM1/CSMM0/CEMM0	
1	POWER CORD ASSY	2H00677G	2H01580M	3H01652N	1
2	MOTOR ASSY	4681A20073D	4681A20174A		1
3	COMPRESSOR	2520UCBK016	2520UCBJ003		1
4	MAIN P.W.B ASSY	6871A10193A			1
5	DISPLAY P.W.B ASSY	6871A20611C			1
6	THERMISTOR	6323A20003S			1
7	CAPACITOR	6120AR2194C			1
8	CONNECTOR ASSY	6631AR3809F			1
9	OVERLOAD PROTECTOR	6750U-L058A			1
10	SYNC. MOTOR	2H01102J			1



# Product Specifications

**Table-1**

ITEMS		MODELS	TWC126CEAB0/CSAB0/CBAB0	TWC126CEMM0/CSMM0/CBMM0	TWC126CBMM0
POWER SUPPLY		1ø, 220V-240V~, 50Hz			
COOLING CAPACITY (Btu/h)		12,000			
INPUT (W)		1,260			
RUNNING CURRENT (A)		5.3			5.6
E.E.R (BTU/W.h)		9.5			
OPERATING CONDITION	INDOOR (°C)	27(DB)*		19(WB)**	
	OUTDOOR (°C)	35(DB)*		24(WB)**	
REFRIGERANT (R-22) CHARGE		400g(14.1 Oz)			
EVAPORATOR		2 ROW 16 STACKS, LOUVERED-FIN TYPE			
CONDENSER		2 ROW 17 STACKS, LOUVERED-FIN TYPE			
FAN, INDOOR		TURBO FAN			
FAN, OUTDOOR		PROPELLER TYPE FAN WITH SLINGER-RING			
FAN SPEEDS, FAN/COOLING		2/3			
FAN MOTOR		6 POLES			
OPERATION CONTROL		ROTARY SWITCH OR ROCKER SWITCH	REMOTE CONTROLLER		
ROOM TEMP. CONTROL		THERMOSTAT	THERMISTOR	THERMOSTAT	
AIR DIRECTION CONTROL		VERTICAL LOUVER (RIGHT & LEFT)			
		HORIZONTAL LOUVER (UP & DOWN)			
CONSTRUCTION		SLIDE IN-OUT CHASSIS			
PROTECTOR	COMPRESSOR	OVERLOAD PROTECTOR			
	FAN MOTOR	INTERNAL THERMAL PROTECTOR			
POWER CORD		1.8m(7") (3 WIRE WITH GROUDING)			
		ATTACHMENT PLUG (CORD-CONNECTED TYPE)			
DRAIN SYSTEM		DRAIN PIPE OR SPLASHED BY FAN SLINGER			
NET WEIGHT (lbs/kg)		90/41			
OUTSIDE DIMENSION (W x H x D)	(inch)	23 <sup>5</sup> / <sub>8</sub> x 14 <sup>31</sup> / <sub>32</sub> x 21 <sup>7</sup> / <sub>8</sub>			
	(mm)	600 x 380 x 555			

\* DB: Dry Bulb

\*\* WB: Wet Bulb

Table-2

ITEMS		MODELS			
		TWC123CBAD0	TWC123CBMM0	TWC126CBAB1/ CNAB1	TWC126CBMM1
POWER SUPPLY		1 $\phi$ , 220V~, 60Hz		1 $\phi$ , 220V-240V~, 50Hz	
COOLING CAPACITY (Btu/h)		12,000		11,500	
INPUT (W)		1,220		1,200	
RUNNING CURRENT (A)		5.5		5.3	
E.E.R (BTU/W.h)		9.8		9.8	
OPERATING CONDITION	INDOOR (°C)	27(DB)*	19(WB)**	27(DB)*	19(WB)**
	OUTDOOR (°C)	35(DB)*	27(WB)**	35(DB)*	24(WB)**
REFRIGERANT (R-22) CHARGE		400g(14.1 Oz)			
EVAPORATOR		2 ROW 13 STACKS, LOUVERED-FIN TYPE		2 ROW 16 STACKS, LOUVERED-FIN TYPE	
CONDENSER		2 ROW 18 STACKS, LOUVERED-FIN TYPE			
FAN, INDOOR		TURBO FAN			
FAN, OUTDOOR		PROPELLER TYPE FAN WITH SLINGER-RING			
FAN SPEEDS, FAN/COOLING		3/3		2/3	
FAN MOTOR		6 POLES			
OPERATION CONTROL		ROTARY SWITCH OR ROCKER SWITCH	REMOTE CONTROLLER	ROTARY SWITCH OR ROCKER SWITCH	REMOTE CONTROLLER
ROOM TEMP. CONTROL		THERMOSTAT	THERMISTOR	THERMOSTAT	THERMISTOR
AIR DIRECTION CONTROL		VERTICAL LOUVER (RIGHT & LEFT)			
		HORIZONTAL LOUVER (UP & DOWN)			
CONSTRUCTION		SLIDE IN-OUT CHASSIS			
PROTECTOR	COMPRESSOR	OVERLOAD PROTECTOR			
	FAN MOTOR	INTERNAL THERMAL PROTECTOR			
POWER CORD		1.8m(7") (3 WIRE WITH GROUING)			
		ATTACHMENT PLUG (CORD-CONNECTED TYPE)			
DRAIN SYSTEM		DRAIN PIPE OR SPLASHED BY FAN SLINGER			
NET WEIGHT (lbs/kg)		90/41			
OUTSIDE DIMENSION (W x H x D)	(inch)	23 <sup>5</sup> / <sub>8</sub> x 14 <sup>31</sup> / <sub>32</sub> x 21 <sup>7</sup> / <sub>8</sub>			
	(mm)	600 x 380 x 555			

\* DB:Dry Bulb

\*\*WB:Wet Bulb

# Exploded View

## COOLING MODEL

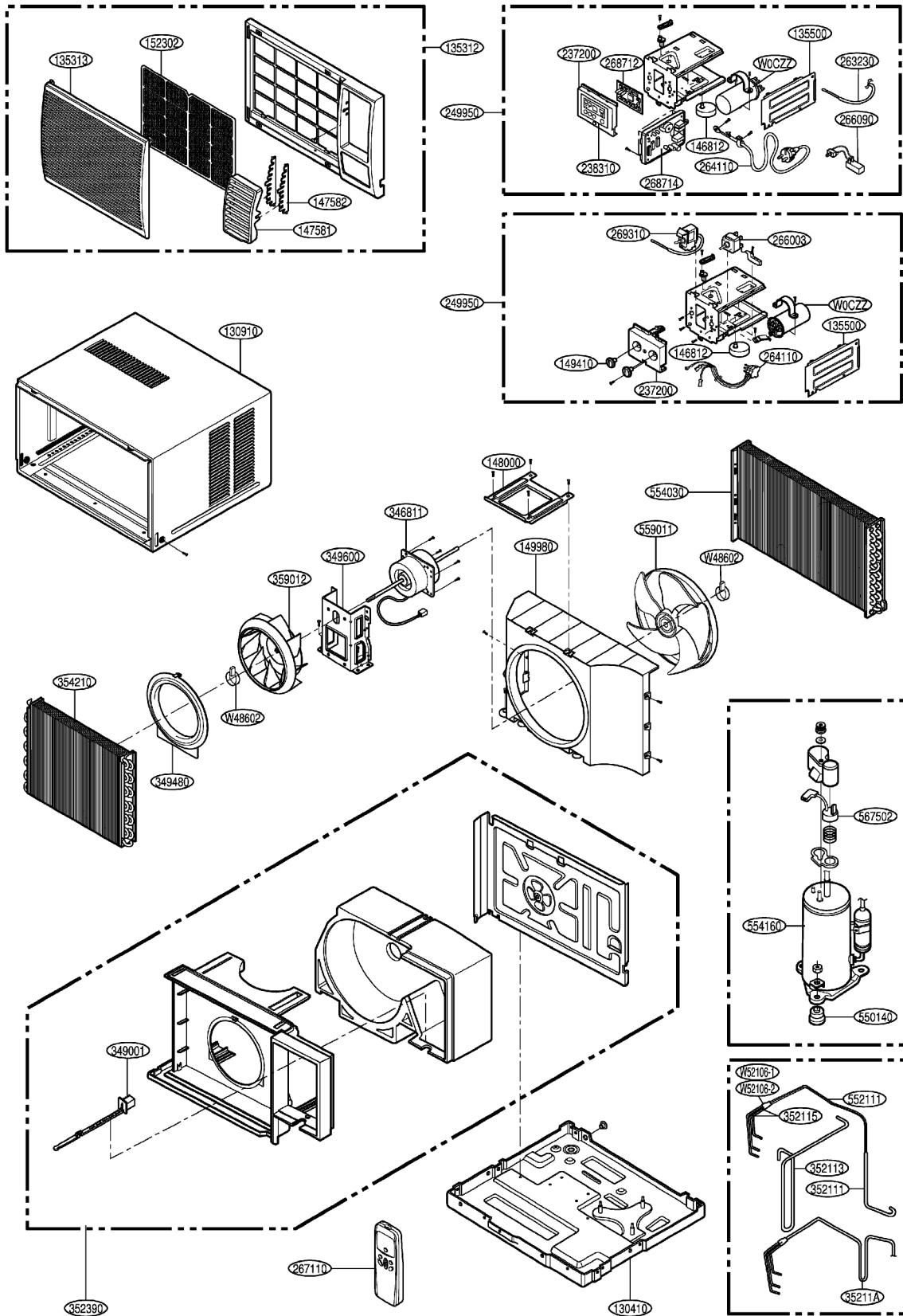

HEATING MODEL

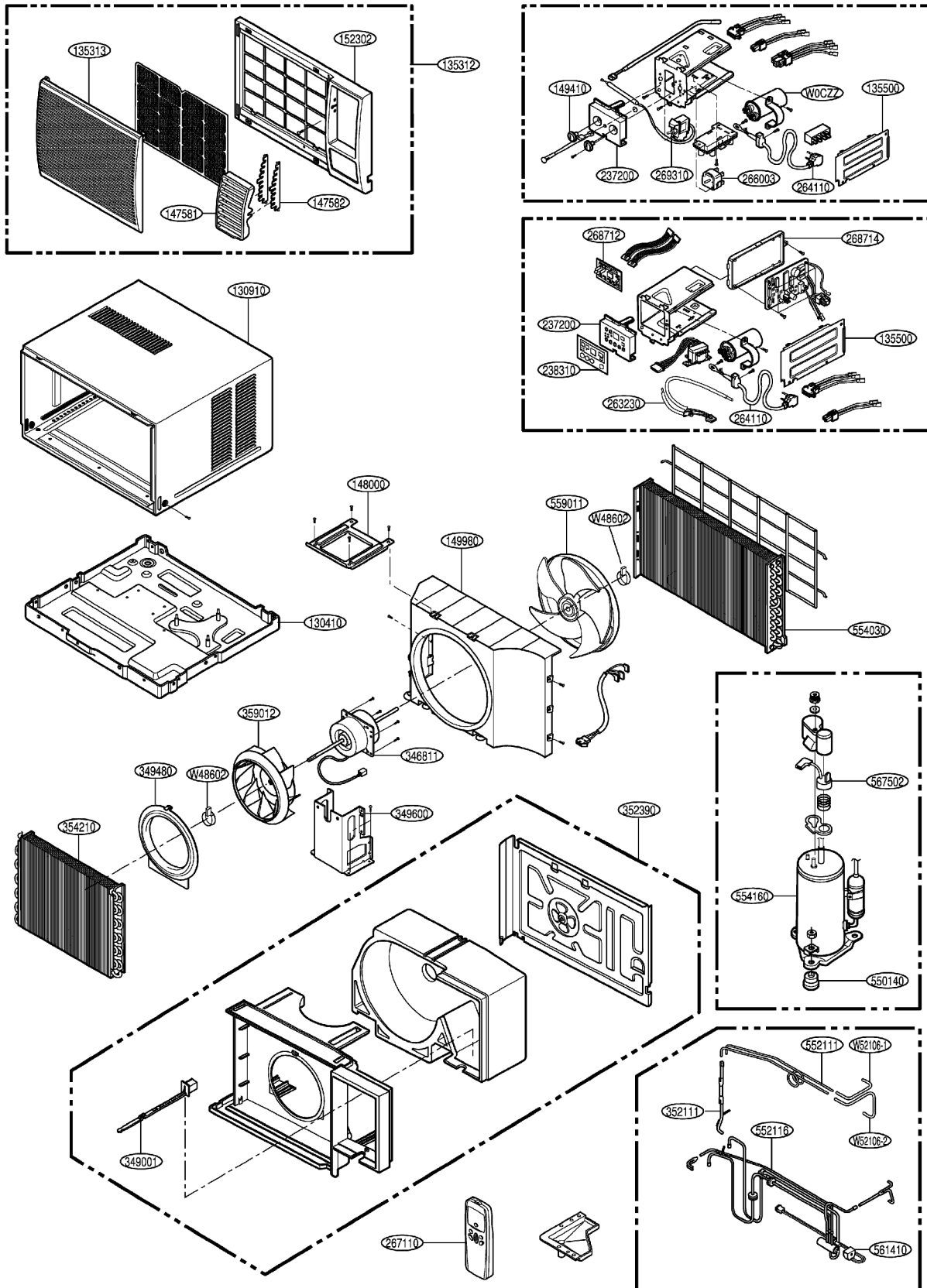

# Replacement Parts List

R:Service Parts

LOCATION NO.	DESCRIPTION	PART NO.					REMARK
		TWC123CBAD0	TWC126CBAB0/CBAB1	TWC126CNAB1	TWC126CEAB0	TWC126CSAB0	
130410	GRILLE ASSY, FRONT(SINGLE)	3041A20012R	3041A20012S			3041A20012E	R
130910	CABINET ASSEMBLY,SINGLE	3091A20029D					R
135312	GRILLE ASSEMBLY,FRONT(SINGLE)	3531A21008C		3531A20129D	3531A20043V	3531A20009T	R
135313	GRILLE, INLET	3530A10182A		3530AR1396A	3530A10034C	3530A10069A	R
135500	COVER ASSY, CONTROL(SINGLE)	3550AR7032A					R
137215	PANEL ASSEMBLY,CONTROL	3721A30009K	3721A30009J/3721A30009N	3721A10015F	3721A10015L	3721A30007B	R
146812	MOTOR ASSEMBLY,SYNC.	2H01102J					R
147581	LOUVER, HORIZONTAL	4758A20051A		4758AR2196A	4758AR2196C	5990AR6191A	R
147582	LOUVER VERTICAL	4758AR2888B					R
148000	BRACE	4800A10001A					R
149410	KNOB ASSEMBLY	4941AR3705G			4941A30010A	4941A30005B	R
149980	SHROUD	4998A10020A					R
152302	FILTER(MECH),A/C	5231AR1152A			5231AR1152C	5231AR1152A	R
249950	CONTROL BOX ASSEMBLY,SINGLE	4995A20510A	4995A21001G/4995A23004H	4995A23004J	4995A23004K	4995A23004L	R
264110	POWER CORD ASSEMBLY	2H00677G	3H03555A/3H01652N	3H01652N			R
266003	SWITCH,ROTARY	2H00598F					R
269310	THERMOSTAT ASSY	2H01109L					R
346811	MOTOR ASSY, SINGLE	4681A20073D	4681A20174A				R
349001	DAMPER, VENTILATION	4900AR7024B					R
349480	ORIFICE	4948A10005B	4948A10005C				R
349600	MOUNT, MOTOR	4960A20005A					R
352111	TUBE ASSY, CONNECTOR	5211A10067E					R
352113	TUBE ASSEMBLY,DISCHARGE	4995A10023N	5211AR2930S				R
35211A	TUBE ASSEMBLY,SUCTION	5211AR2926H	5211A20228H				R
352390	AIR GUIDE ASSEMBLY	5239AR1523J	5239A20027A				R
354210	EVAPORATOR ASSEMBLY,FIRST	5421AR2912E	5421AR2910H				R
359012	FAN,TURBO	5900A20030A					R
550140	ISOLATOR,COMP	4830AR4335A					R
552101	TUBE, CAPILLARY	5211A21448A	5211A21448C				R
554030	CONDENSER ASSEMBLY,FIRST	5403A20083E		5403A20083D	5403A20083E	5403A20083D	R
554160	COMPRESSOR SET	2520UCBK016	2520UCBJ003				R
559011	FAN,AXIAL	5900A10009B					R
567502	O.L.P	6750U-L058A					R
W0CZZ	CAPACITOR,DRAWING	6120AR2194C	6120AR2194C/6120AR2194A	6120AR2194C			R
W48602	CLAMP, SPRING	3H02932B					R
W52106-1	TUBE,EVAPORATOR(FORMED)	5210AR4352A	5210A20351E				R
W52106-2	TUBE,EVAPORATOR(FORMED)	5210AR4353A	5210A20352E				R

Replacement Parts List

R:Service Parts

LOCATION NO.	DESCRIPTION	PART NO.					REMARK
		TWC123CBMM0	TWC126CBMM0	TWC126CBMM1	TWC126CSMM0	TWC126CEMM0	
130410	BASE ASSEMBLY,SINGLE	3041A20012R	3041A20012D	3041A20012S			R
130910	CABINET ASSEMBLY,SINGLE	3091A20029D					R
135312	GRILLE ASSEMBLY,FRONT(SINGLE)	3531A21008C			3531A20009T	3531A20043V	R
135313	GRILLE, INLET	3530A10182A			3530A10069A	3530A10034C	R
135500	COVER ASSY, CONTROL(SINGLE)	3550AR7032A					R
146812	SYNC. MOTOR	2H01102J					R
147581	LOUVER, HORIZONTAL	4758A20051A			5990AR6191A	4758AR2196C	R
147582	LOUVER VERTICAL	4758AR2888B					R
148000	BRACE	4800A10001A					R
149980	SHROUD	4998A10020A					R
152302	FILTER ASSY, A/C	5231AR1152A			5231AR1152C		R
237200	PANEL, CONTROL	3720A10003B					R
238310	ESCUTCHEON	3831A20034H		3831A20034S	3831A20034M	3831A20034H	R
249950	CONTROL BOX ASSY, SINGLE	4995A20481H	4995A20481F	4995A20481K	4995A20481G	4995A20481J	R
263230	THERMISTOR	6323A20003S					R
264110	POWER CORD ASSY	2H00677G	2H01580M	3H01652N			R
267110	REMOTE CONTROLLER ASSY	6711A20034F		6711A20034N	6711A20035P	6711A20034N	R
268712	PWB(PCB) ASSY, DISPLY	6871A20611C					R
268714	PWB(PCB) ASSY, MAIN	6871A10193A					R
346811	MOTOR ASSY, SINGLE	4681A20073D	4681A20174A				R
349001	DAMPER, VENTILATION	4900AR7024B					R
349480	ORIFICE	4948A10005B	4948A10005C				R
349600	MOUNT, MOTOR	4960A20005A					R
352111	TUBE ASSY, CONNECTOR	5211A10067E					R
352113	TUBE ASSY, DISCHARGE	5211A20644A	5211AR2930S				R
35211A	TUBE ASSY, SUCTION	5211AR2926H	5211A20228H				R
352390	AIR GUIDE ASSY	5239AR1523J	5239A20027A		5239AR1523J	5239A20027A	R
354210	EVAPORATOR ASSY	5421AR2912E	5421AR2910H				R
359012	FAN, SIDE	5900A20030A					R
552101	TUBE, CAPILLARY	5211A21448A	5211A21448C				R
554030	CONDENSER ASSY	5403A20083E					R
554160	COMPRESSOR	2520UCBK016	2520UCBJ003				R
559011	FAN ASSY, AXIAL	5900A10009B					R
567502	OVERLOAD PROTECTOR	6750U-L058A					R
W0CZZ	CAPACITOR	6120AR2194C					R
W48602	CLAMP, SPRING	3H02932B					R
W52106-1	TUBE FORMED	5210AR7090B	5210A20351E				R
W52106-2	TUBE FORMED	—	5210A20352E				R