

SERVICING PRECAUTIONS

AIR RECHARGING IN COMPRESSOR

Test the refrigeration system connecting it electrically before refilling operation. It is necessary to ascertain the function of the motor-compressor and identify the defects immediately. If defects have been found, empty the old system of possible R-12(R134a) residue by breaking off the end of the extension piece at its narrow point. (Figure 1)

Replace the filter and any damaged components. Unsolder and pull off the piece remaining inside the service tube and then attach an complete extension with male Hansen and at last, solder it to the same tube again. (Figure 2)

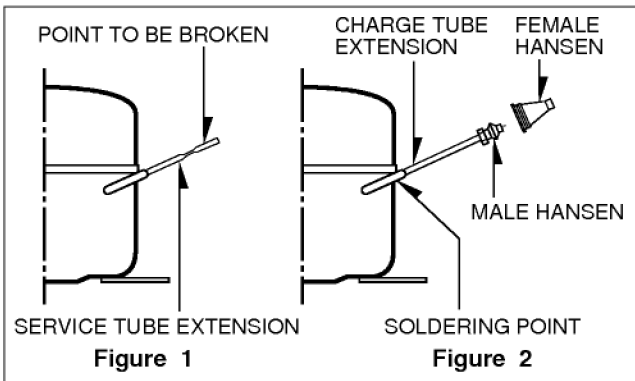

It is necessary to execute the soldering operation with valve open so that the fumes caused by oil residue can come out freely without blowholes between two tubes during the heating the of the point to be soldered. The extension fitted with the male Hansen is connected to the female fitting of the vacuum pump tube. (Figure 3)

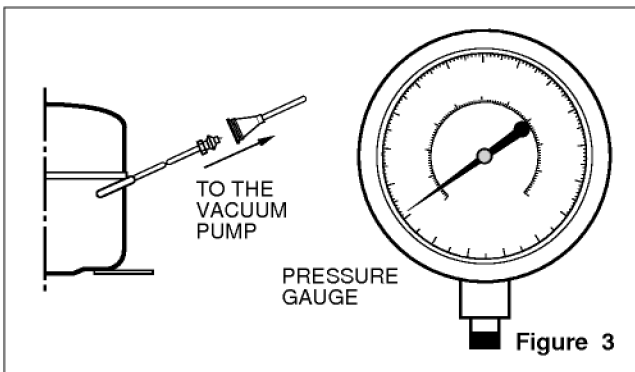

Air evacuating from the system begins as soon as the pump starts. The refrigeration system must be kept under vacuum until the reading on the low-pressure gauge indicates vacuum (0 absolute, -1 atm., -760 mm hg) in any case it is advisable to keep the pump running for about 30 minutes. (Figure 3)

In case that a considerable leakage occurs it will be necessary to stop the vacuum pump and to add a small quantity of Freon to the system, if vacuum should not be obtained (pressure gauge can't fall to 1 atmosphere), start the refrigeration unit and find the leakage with the special leak-finder. When the defective soldering point is visible, re-do it after opening the extension tube valve and reestablishing the normal outside pressure inside the group.

Because the melted alloy is sucked into the tubes and block them, the pressure must be rebalanced when vacuum is in the system in soldering. As soon as the

vacuum operation is over, add the quantity in grams of R-12(R134a) to the refrigeration system. Remember that every system has an exact quantity of R-12(R134a) with a tolerance of ± 5 grams that can be added. (Figure 4)

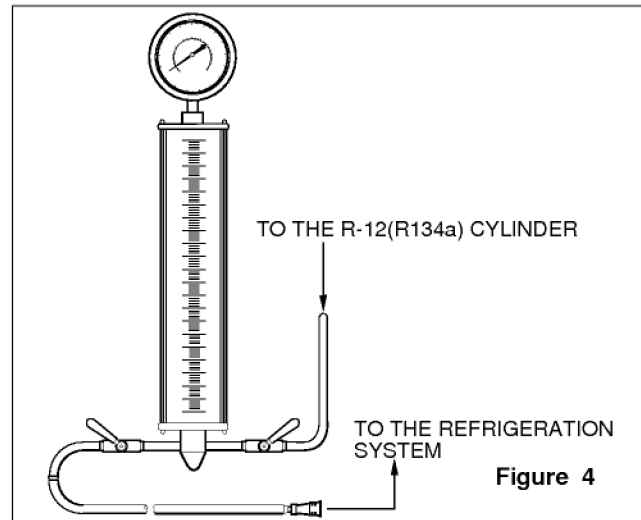

Before performing this operation (if the vacuum pump and refilling cylinder are connected), make sure that the valve placed between the vacuum pump and the refilling tube are closed in order to keep the Freon for addition to the system. (Figure 5)

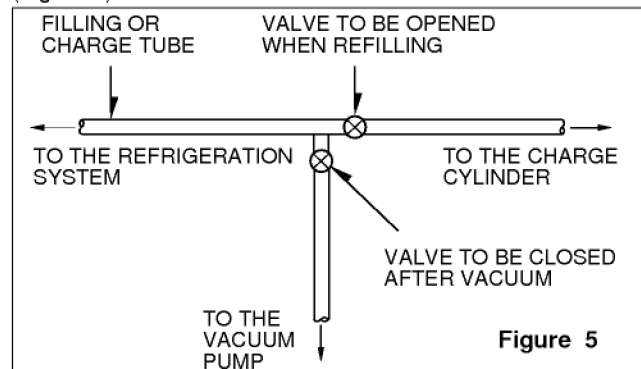

In addition, check the graduated scale on the cylinder for the quantity of R-12(R134a) to be added, for example, if we have 750 grams of Freon in the cylinder and must add 140 grams to the group, this amount will be reached when R-12(R134a) has dropped to 610 grams, remembering that the indicator shows a lower limit of meniscus. Do this after choosing the scale corresponding to the gas pressure different scales reported as the same gas pressure indicated by the pressure gauge on the top of the column. To make R-12(R134a) flow into the system, open the valve placed at the base of the cylinder and connected to the filling tube. The amount of Freon cannot be added to the system all at once because it may cause a blocking of motor-compressor. Therefore, proceed by adding the original quantity of about 20-30 grams and close the valve immediately.

The pressure rises and the motor compressor must start sucking the gas and lowering the pressure again. Regulate the valve again, maintaining the same manner until reaching to the quantity of R-12(R134a) established for the system being charged. When the system is running, the suction pressure must be stabilized between 0.30 to 0.6(0.10 to 0.4) atmosphere.

1. SPECIFICATIONS

1-1. Ref. No.: GR-T622DE

ITEMS	SPECIFICATIONS
DOOR DESIGN	Side Rounded
DIMENSIONS (mm)	750x723x1732(WxDxH)
NET WEIGHT (kg)	90
COOLING SYSTEM	Fan Cooling
TEMPERATURE CONTROL	Knob Dial
DEFROSTING SYSTEM	Full Automatic Heater Defrost With a Timer
DOOR FINISH	Embossed Metal
HANDLE TYPE	Bar
INNER CASE	ABS Resin
INSULATION	Polyurethane Foam

ITEMS	SPECIFICATIONS
VEGETABLE TRAY	Transparent Drawer Type
COMPRESSOR	PTC Starting Type
EVAPORATOR	Fin Tube Type
CONDENSER	Wire Condenser
REFRIGERANT	R-134a (140 g)
LUBRICATING OIL	Freol @ 15G (320 cc)
DEFROSTING DEVICE	SHEATH HEATER
LAMP	FREEZER REFRIGERATOR
	15 W* 40 W

* Freezer lamp is optional part.

1-2. Ref. No.: GR-T722DE

ITEMS	SPECIFICATIONS
DOOR DESIGN	Side Round
DIMENSIONS (mm)	750x776x1732(WxDxH)
NET WEIGHT (kg)	93
COOLING SYSTEM	Fan Cooling
TEMPERATURE CONTROL	Knob Dial
DEFROSTING SYSTEM	Full Automatic Heater Defrost With a Timer
DOOR FINISH	Pre Coated Metal
INNER CASE	ABS Resin
INSULATION	Polyurethane Foam

ITEMS	SPECIFICATIONS
VEGETABLE TRAY	Transparent Drawer Type
COMPRESSOR	PTC Starting Type
EVAPORATOR	Fin Tube Type
CONDENSER	Wire Condenser
REFRIGERANT	R-134a (140 g)
LUBRICATING OIL	Freol @ 15G (320 cc)
DEFROSTING DEVICE	SHEATH HEATER
LAMP	FREEZER REFRIGERATOR
	15 W* 40 W

* Freezer lamp is optional part.

2. PARTS IDENTIFICATION

FREEZER COMPARTMENT

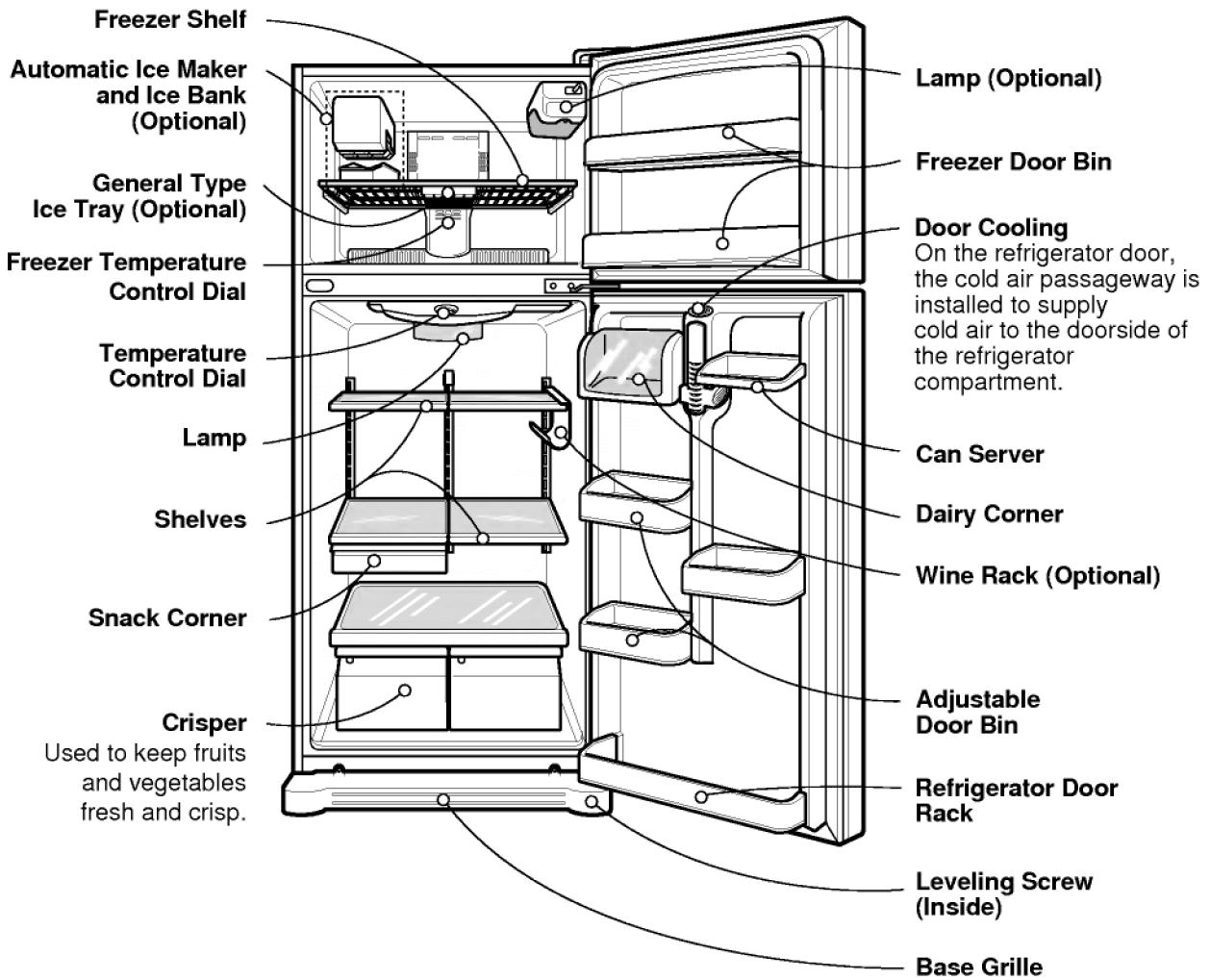

3. DISASSEMBLY

3-1 DOOR

● Freezer Door

1. Remove the hinge cover by pulling it upwards.
2. Loosen hexagonal bolts fixing the upper hinge to the body and lift the freezer door.

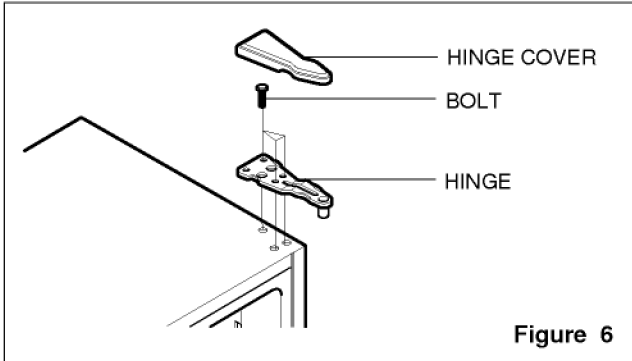

3. Pull out the door gasket to remove from the door foam Ass'y.

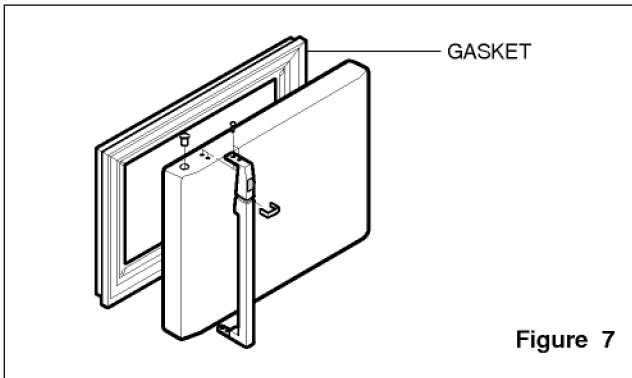

● Refrigerator Door

1. Loosen hexagonal bolts fixing the lower hinge to the body to remove the refrigerator door only.

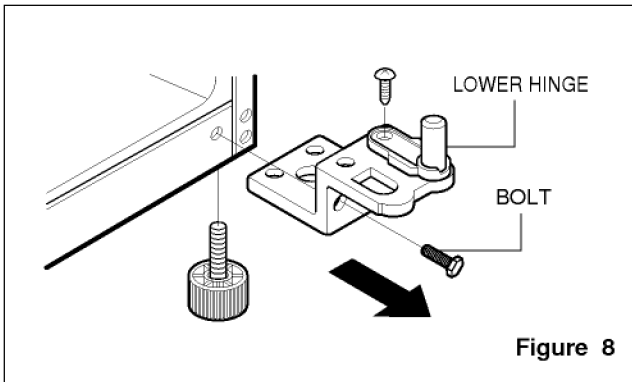

2. Pull out the door gasket to remove from the door foam Ass'y.

3-2 DOOR SWITCH

1. To remove the door switch, pull out it with a '-' type driver as shown in (figure 9).
2. Disconnect the lead wire from the switch.

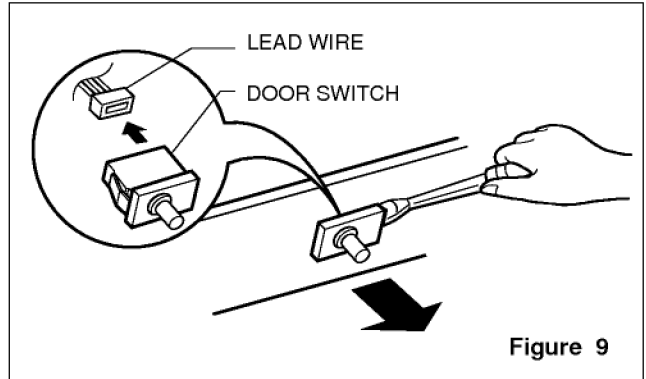

3-3 THERMOSTAT

1. Remove Control Box-R by loosening 2 screw fixed to ceiling of Refrigerator compartment (Figure 10)
2. Separate the thermostat and dial knob F.
3. Remove the thermostat by disconnecting the lead wire.

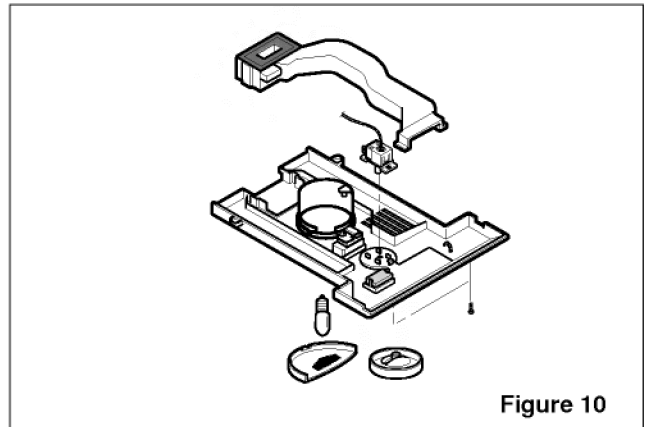

3.4 FAN AND FAN MOTOR

1. Remove the freezer shelf. (If your refrigerator have an Ice Maker, disassemble the Ice maker first)
2. Remove the Grille by pulling it out and by loosening a screw.
3. Remove the Fan Motor Assy by loosening 4 screws and disassemble the shroud.
4. Pull out the fan and, separate the Fan Motor, Bracket.

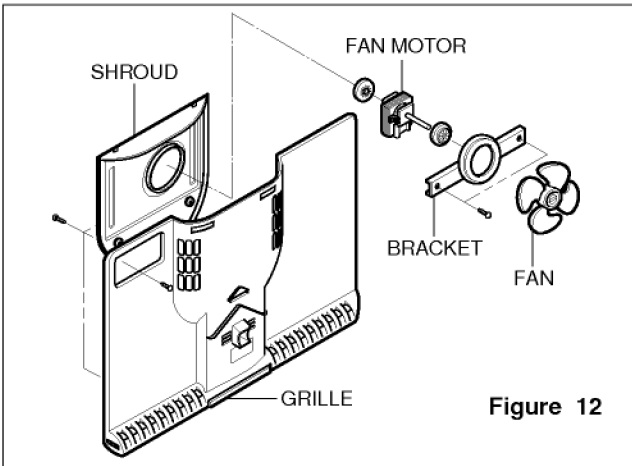

Figure 12

3-5 DEF' CONTROL ASSY

Def control Assy consists of Defrost Thermostat and FUSE-M. Defrost Thermostat functions to defrost automatically and it is attached to metal side of the Evaporator and senses Temp.

Fuse-M is a kind of safety device for preventing over-heating of the Heater when defrosting.

At the temperature of 77°C, it stops the emission of heat from the Heater.

1. Pull out the Grille Ass'y.
2. Separate the connector connected with the Def Control Assy and replace the Def Control Assy after cutting the Tie Wrap. (Figure 14)

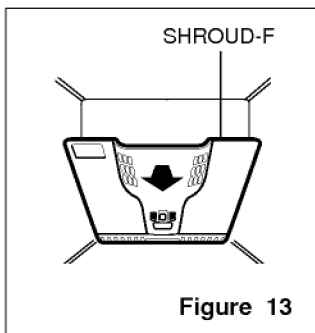

Figure 13

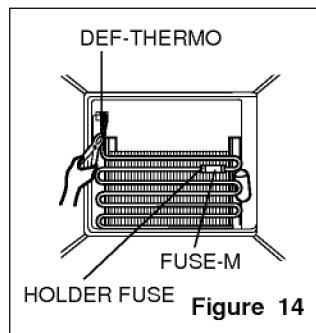

Figure 14

3-6 LAMP

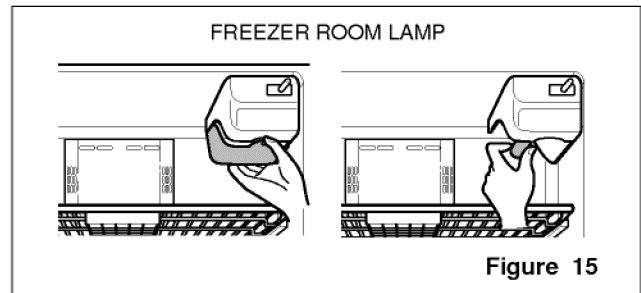

Figure 15

3-6-1 Freezer room lamp

1. Unplug the power cord from the outlet.
2. Remove the room lamp lid by taking down while pushing it backward with your hand after grabbing the hook of lamp lid as shown in the figure at right.
3. Remove the lamp by turning it clockwise and replace new one.
4. Assemble in reverse order of disassembly. Replacement bulb must be the same specification as original. (Max 15W)

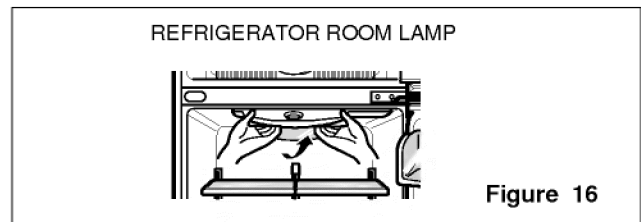

Figure 16

3-6-2 Refrigerator room lamp

1. Unplug the power cord from the outlet.
2. Remove refrigerator shelves.
3. Upper Refrigerator Lamp. Release the hooks on both ends of the lamp shield and pull the shield downward to remove it.
4. Turn the lamp counterclockwise.
5. Assemble in reverse order of disassembly. Replacement bulb must be the same specification as original. (Max 40 W)

3-7 CONTROL BOX-R

1. First, remove all shelves in the refrigerator and Control Box-R by loosening 2 screw.

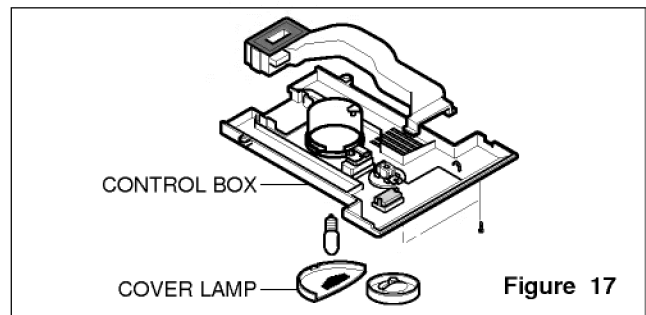

Figure 17

2. Remove the Control Box-R by pulling it downward.
3. Disconnect the L/wire on the right position and separate timer, thermostat, Lamp socket, etc.

4. ADJUSTMENT

4-1 COMPRESSOR

4-1-1 Role

The compressor intakes low temperature and low pressure gas evaporated from Evaporator of the Refrigerator, and condenses this gas to high temperature and high pressure gas, and then plays delivering role to Condenser.

4-1-2 Composition

The Compressor is Composed of Compressor Apparatus compressing gas, Compressor Motor moving Compressor Apparatus and Case protecting Compressor Apparatus and Motor. There are PTC-Starter, and Over Load Protector (OLP) in the Compressor outside. On the other hand, because the Compressor consists of 1/1000mm processing precision components and is sealed after production in absence of dust or humidity, deal and repair with care.

4-1-3 Note for Usage

- (1) Be careful not to allow over-voltage and over-current.
- (2) No Strike
If applying forcible power or strike (dropping or careless dealing), poor operation and noise may occur.
- (3) Use proper electric components appropriate to the Compressor.
- (4) Note to Keep Compressor.
If Compressor gets wet in the rain and rust in the pin of Hermetic Terminal, the result may be poor operation and poor contact may cause.
- (5) Be careful that dust, humidity, and flux welding don't inflow in the Compressor inside in replacing the Compressor. Dust, humidity, and flux due to welding which inflows to Cylinder may cause lockage and noise.

4-2 PTC-STARTER

4-2-1 Composition of PTC-Starter

- (1) PTC (Positive Temperature Coefficient) is a no-contact semiconductor starting device which uses ceramic material and this material consists of BaTiO₃.
- (2) The higher the temperature is, the higher becomes the resistance value. These features are used as starting device for the Motor.

4-2-2 Role of PTC-Starter

- (1) PTC is attached to Hermetic Compressor used for Refrigerator, Show Case and starts Motor.
- (2) Compressor for household refrigerator applies to single-phase induction Motor.
For normal operation of the single-phase induction motor, in the starting operation flows in both main coil and sub-coil. After the starting is over, the current in subcoil is cut off. The proper features of PTC play all the above roles. So, PTC is used as a motor starting device.

4-2-3 PTC-Applied Circuit Diagram

● According to Starting Method for the Motor

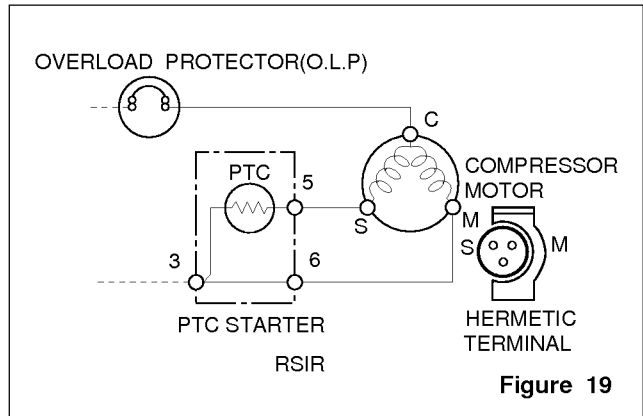

Figure 19

4-2-4 Motor Restarting and PTC Cooling

- (1) For restarting after power off during normal Compressor Motor operation, plug the power cord after 5 min. for pressure balance of Refrigerating Cycle and PTC cooling.
- (2) During normal operation of the Compressor Motor, PTC elements generate heat continuously. Therefore, if PTC isn't cooled for a while after the power has been shut off, Motor can't operate again.

4-2-5 Relation of PTC-Starter and OLP

- (1) If the power is off during operation of Compressor and the power is on before the PTC is cooled, (instant shut-off within 2 min. or reconnect a power plug due to misconnecting), the PTC isn't cooled and a resistance value grows. As a result, current can't flow to the sub-coil and the Motor can't operate and the OLP operates by flowing over current in only in the main-coil.
- (2) While the OLP repeats on and off operation about 3-5 times, PTC is cooled and Compressor Motor performs normal operation.
If OLP doesn't operate when PTC is not cooled, Compressor Motor is worn away and causes circuit-short and fire. Therefore, use a properly fixed OLP without fail.

4-2-6 Note to Use PTC-Starter

- (1) Be careful not to allow over-voltage and over-current.
- (2) No Strike
Don't apply a forcible power or strike.
- (3) Keep apart from any liquid.
If liquid such as oil or water away enter the PTC, PTC materials it may break due to insulation breakdown of the material itself.
- (4) Don't change PTC at your convenience.
Don't disassemble PTC and mold. If the exterior to the PTC-starter is damaged, resistance value is altered and it may cause poor starting of the compressor motor may cause.
- (5) Use a properly fixed PTC.

4-3 OLP (OVERLOAD PROTECTOR)

4-3-1 Definition of OLP

- (1) OLP (OVERLOAD PROTECTOR) is attached to the Compressor and protects the Motor by cutting the current to the Motor if the temperature rises and activates the bimetal spring in the OLP.
- (2) When over-voltage flows to Compressor motor, the Bimetal works by heating the heater inside the OLP, and the OLP protects Motor by cutting off current which flows to the Compressor Motor.

4-3-2 Role of the OLP

- (1) The OLP is attached to the Hermetic Compressor used for the Refrigerator and Show Case and prevents the Motor Coil from being started in the Compressor.
- (2) Do not turn the Adjust Screw of the OLP in any way for normal operation of the OLP.
(Composition and connection Diagram of OLP)

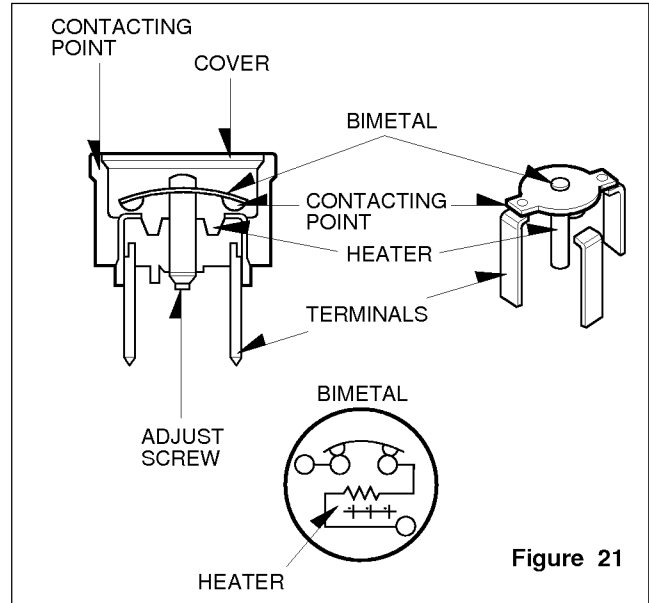
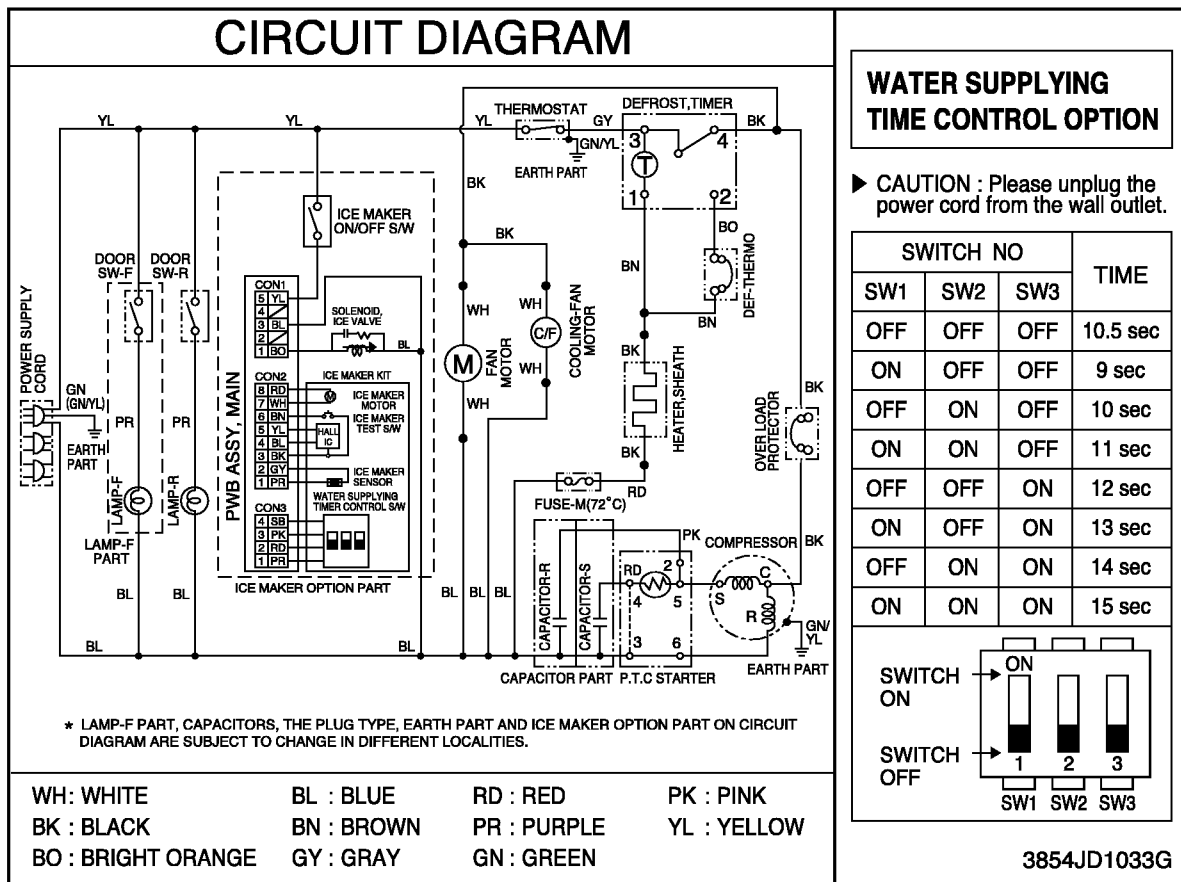

Figure 21

5. CIRCUIT DIAGRAM



NOTE : 1. This is a basic diagram and specifications vary in different localities.

4-3 OLP (OVERLOAD PROTECTOR)

4-3-1 Definition of OLP

- (1) OLP (OVERLOAD PROTECTOR) is attached to the Compressor and protects the Motor by cutting the current to the Motor if the temperature rises and activates the bimetal spring in the OLP.
- (2) When over-voltage flows to Compressor motor, the Bimetal works by heating the heater inside the OLP, and the OLP protects Motor by cutting off current which flows to the Compressor Motor.

4-3-2 Role of the OLP

- (1) The OLP is attached to the Hermetic Compressor used for the Refrigerator and Show Case and prevents the Motor Coil from being started in the Compressor.
- (2) Do not turn the Adjust Screw of the OLP in any way for normal operation of the OLP.
(Composition and connection Diagram of OLP)

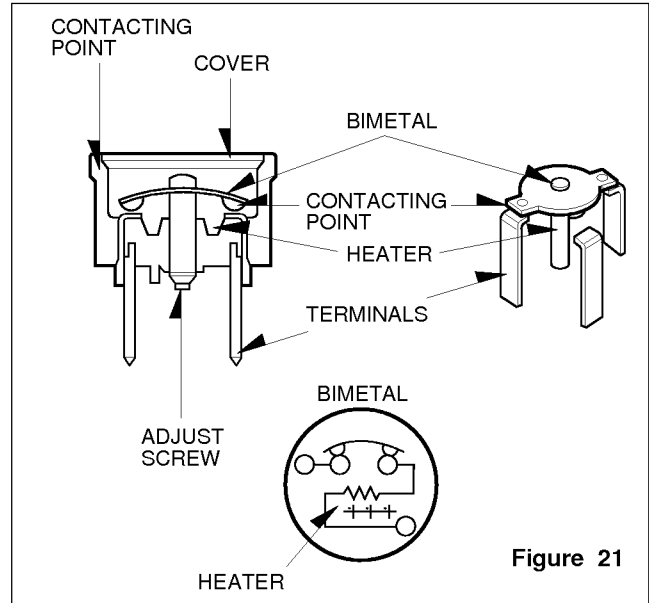
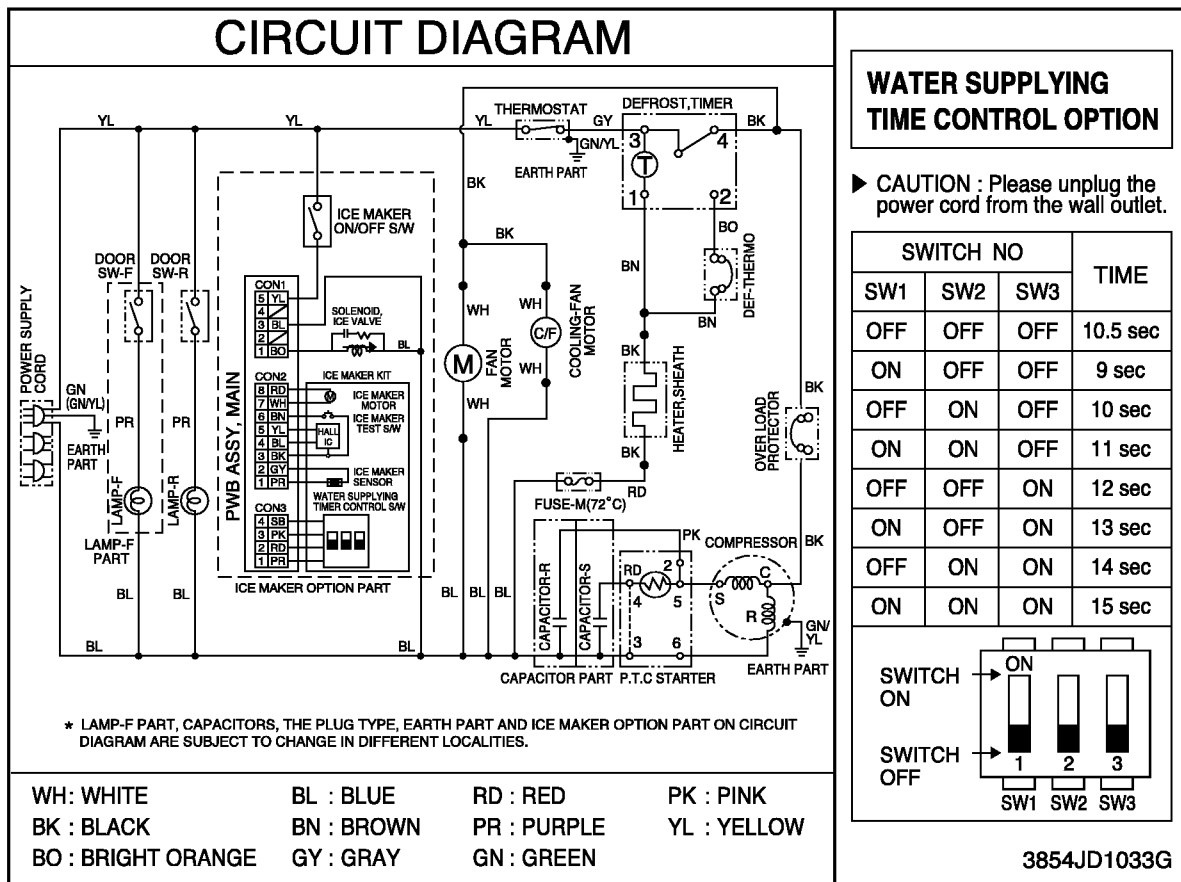

Figure 21

5. CIRCUIT DIAGRAM



NOTE : 1. This is a basic diagram and specifications vary in different localities.

6. TROUBLESHOOTING

6-1 COMPRESSOR AND ELECTRIC COMPONENTS

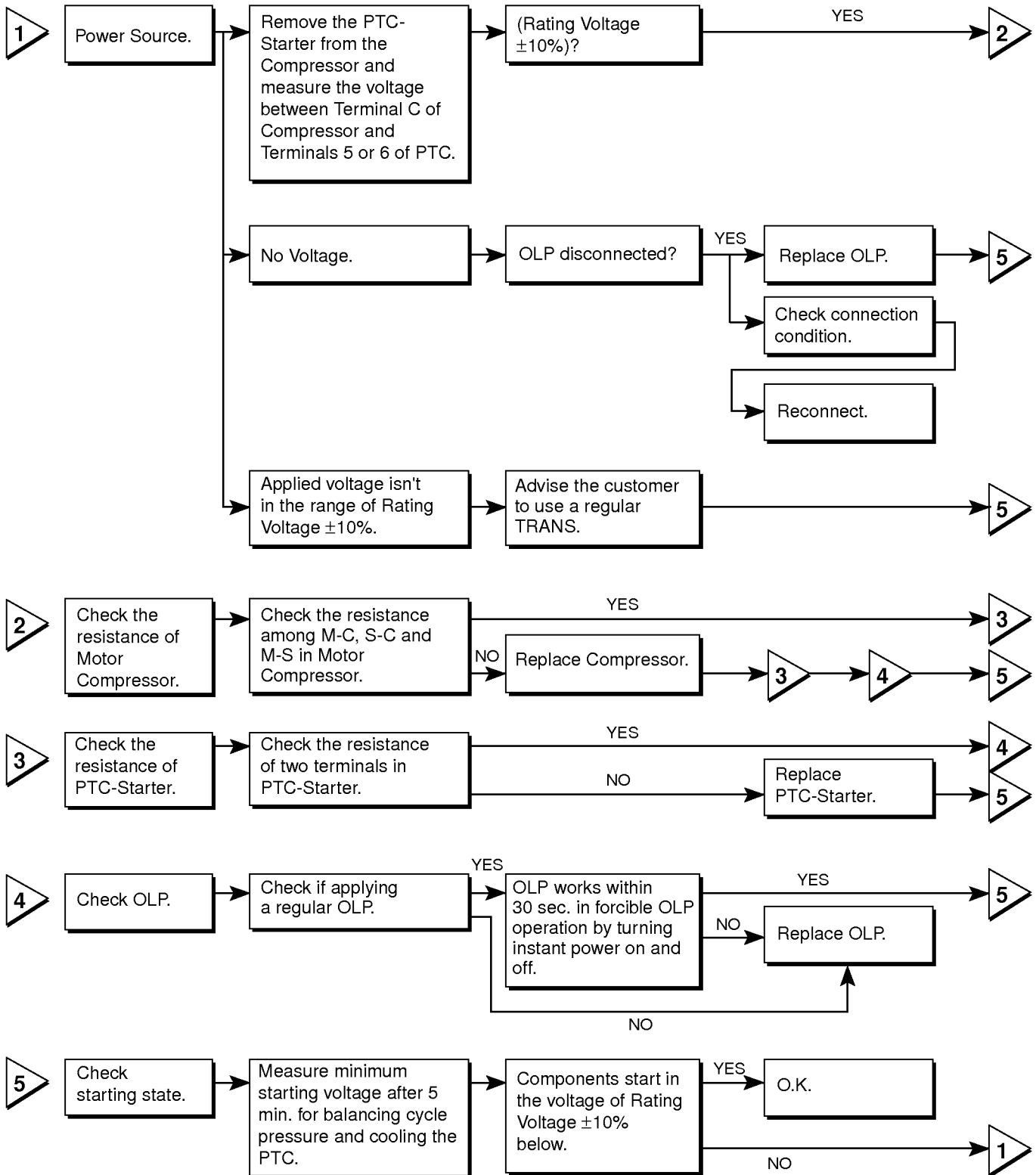

6-2 PTC AND OLP

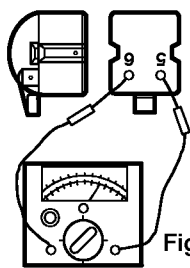
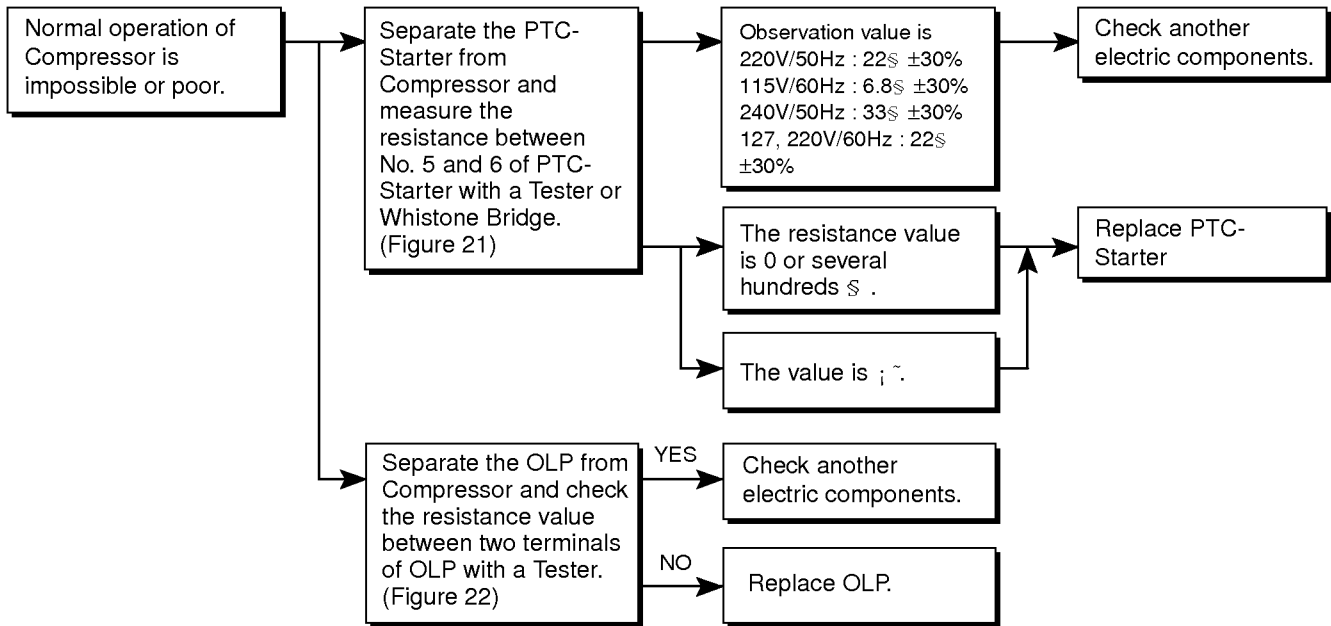

Figure 21

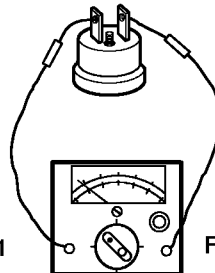

Figure 22

6-3 DEFROST TIMER

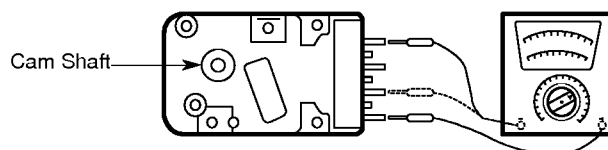
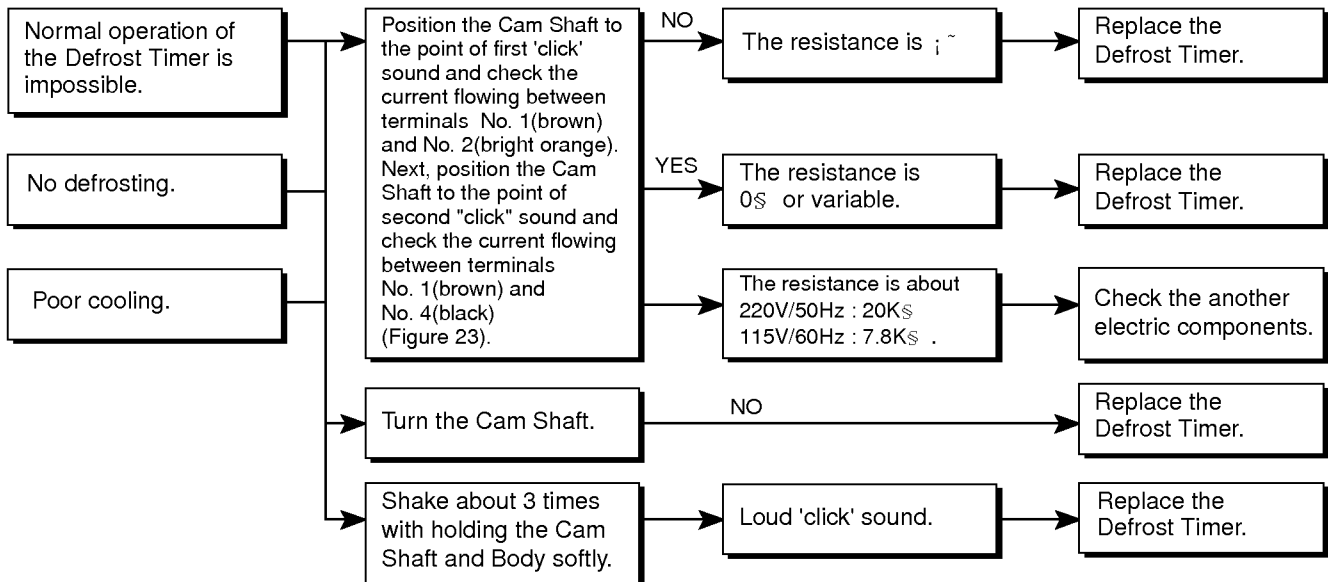
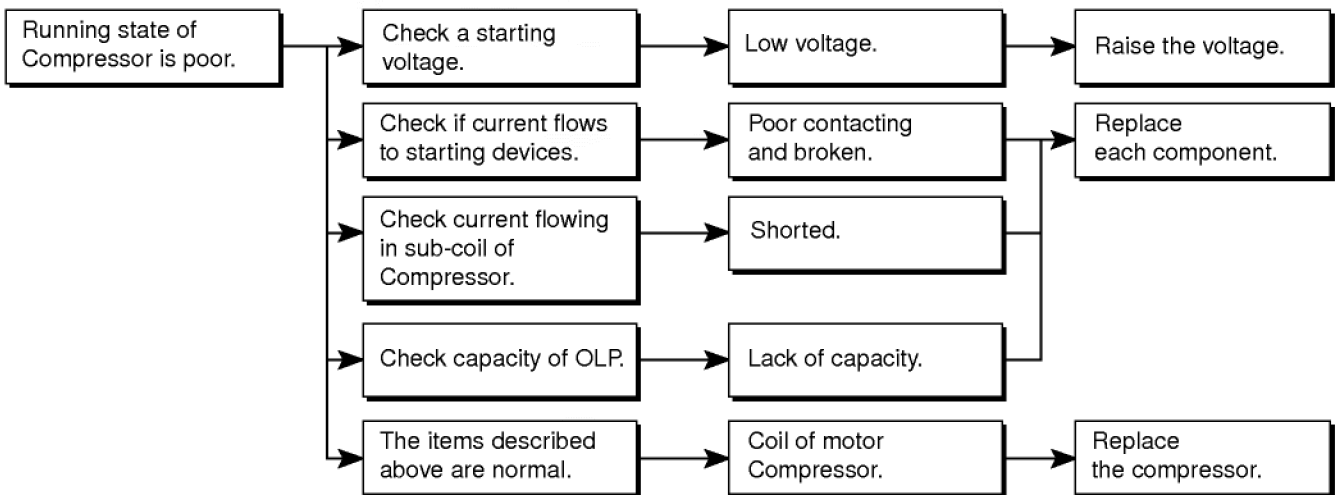
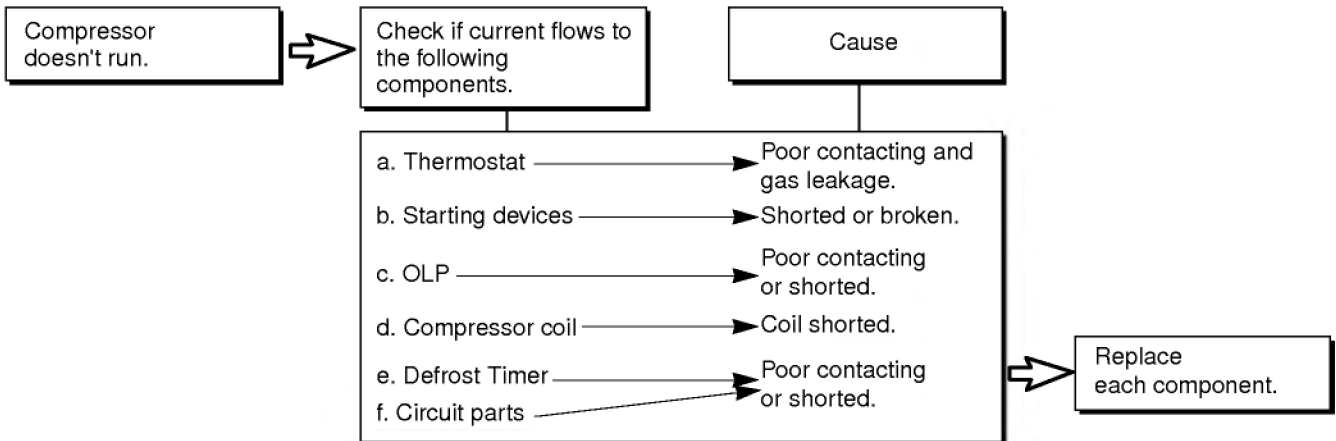

Figure 23

6-4 ANOTHER ELECTRIC COMPONENTS

▼ Cooling is impossible



▼ Cooling ability is poor

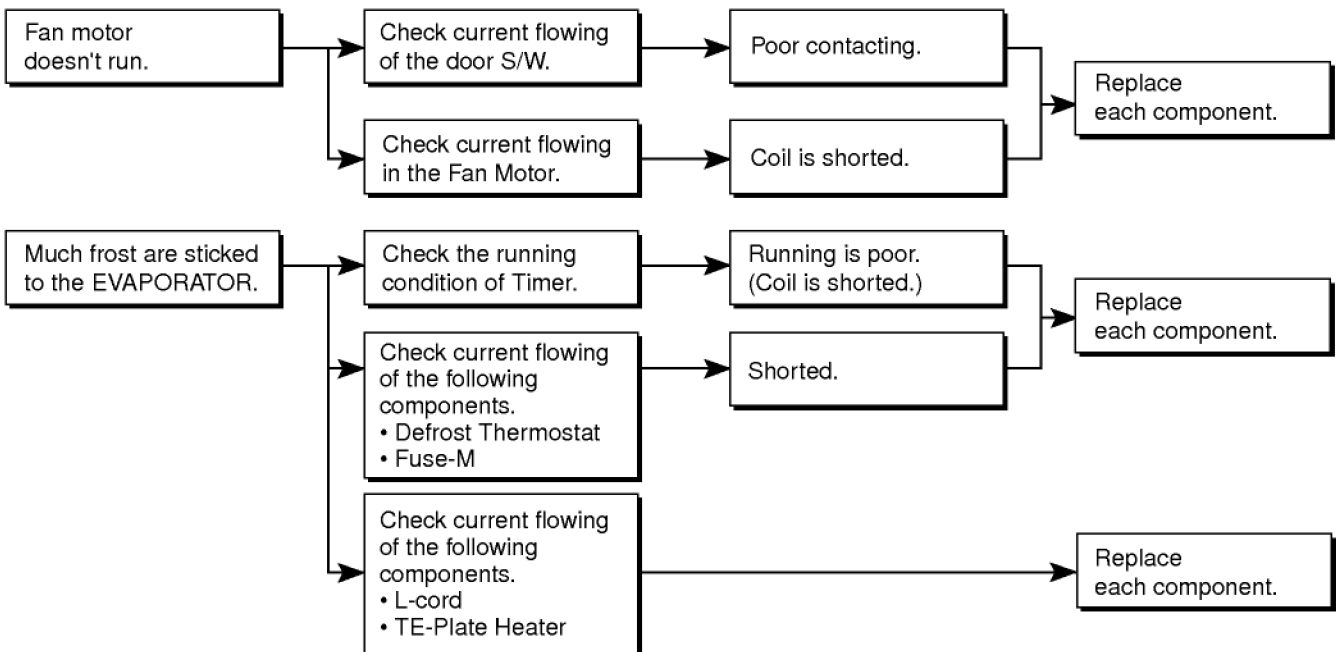

6-4 SERVICE DIAGNOSIS CHART

COMPLAINT	POINTS TO BE CHECKED	REMEDY
Cooling is impossible.	<ul style="list-style-type: none"> • Is the power cord unplugged from the outlet? • Check if the power S/W is set to OFF. • Check if the fuse of power S/W is shorted. • Measure the voltage of power outlet. 	<ul style="list-style-type: none"> • Plug to the outlet. • Set the switch to ON. • Replace a regular fuse. • If voltage is low, wire newly.
Cooling ability is poor.	<ul style="list-style-type: none"> • Check if the set is placed close to wall. • Check if the set is placed close to stove, gas cooker and direct rays. • Is the ambient temperature high or the room door closed? • Check if put in is hot. • Did you open the door of the set too often or check if the door is closed up? • Check if the Control is set to "COLD (1)". 	<ul style="list-style-type: none"> • Place the set with the space of about 10cm. • Place the set apart from these heat appliances. • Make the ambient temperature below. • Put in foods after cooled down. • Don't open the door too often and close it firmly. • Set the control to mid-position.
Foods in the Refrigerator are frozen.	<ul style="list-style-type: none"> • Is foods placed in cooling air outlet? • Check if the Dial is set to "COLD (8)". • Is the ambient temperature below 5°C? 	<ul style="list-style-type: none"> • Place foods in high temperature section. (Front Part) • Set the dial to "MID (5)". • Set the dial to "WARM (1)".
Dew or ice forms in the chamber of the set.	<ul style="list-style-type: none"> • Is liquid food stored? • Check if put in is hot. • Did you open the door of the set too often or check if the door is closed up. 	<ul style="list-style-type: none"> • Seal up liquid foods with wrap. • Put in foods after cooled down. • Don't open the door too often and close it firmly.
Dew forms in the Exterior Case.	<ul style="list-style-type: none"> • Check if ambient temperature and humidity of surrounding air are high. • Is there gap in the door packed? 	<ul style="list-style-type: none"> • Wipe dew with a dry cloth. This occurrence is solved naturally in low temperature and humidity. • Fill up the gap.
Abnormal noise generates.	<ul style="list-style-type: none"> • Are the set positioned in a firm and even place? • Are any unnecessary objects set in the back side of the set? • Check if the Drip Tray is not firmly fixed. • Check if the cover of mechanical room in below and front side is taken out. 	<ul style="list-style-type: none"> • Adjust the Adjust Screw, and position in the firm place. • Remove the objects. • Fix it firmly on the original position. • Place the cover at the original position.
To close the door is not handy.	<ul style="list-style-type: none"> • Check if the door packing is dirty with filth such as juice. • Is the set positioned in a firm and even place? • Is too much food putted in the set? 	<ul style="list-style-type: none"> • Clean the door packing. • Position in the firm place and adjust the Adjust Screw. • Keep foods not to reach the door.
Ice and foods smell unpleasant.	<ul style="list-style-type: none"> • Check if the inside of the set is dirty. • Did you keep smelly foods without wrapping? • It smells of plastic. 	<ul style="list-style-type: none"> • Clean the inside of the set. • Wrap smelly foods. • The new products smells of plastic, but it is eliminated after 1-2 weeks.

● In addition to the items described left, refer to the followings to solve the complaint.

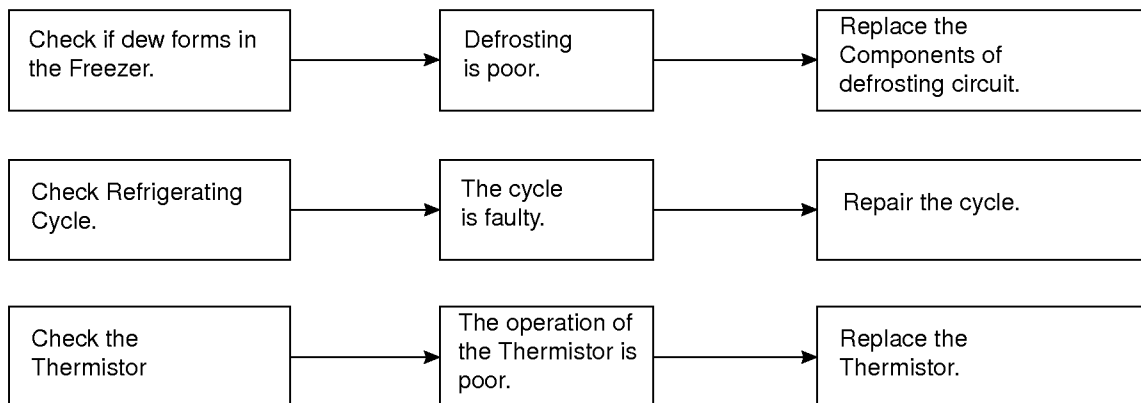

6-5 REFRIGERATING CYCLE

▼ Troubleshooting Chart

CAUSE		STATE OF THE SET	STATE OF THE EVAPORATOR	TEMPERATURE OF THE COMPRESSOR	REMARKS
LEAKAGE	PARTIAL LEAKAGE	Freezer room and Refrigerator don't cool normally.	Low flowing sound of Refrigerant is heard and frost forms in inlet only	A little high more than ambient temperature.	<ul style="list-style-type: none"> • A little Refrigerant discharges. • Normal cooling is possible when injecting of Refrigerant the regular amount.
	WHOLE LEAKAGE	Freezer room and Refrigerator don't cool normally.	Flowing sound of Refrigerant is not heard and frost isn't formed.	Equal to ambient temperature.	<ul style="list-style-type: none"> • No discharging of Refrigerant. • Normal cooling is possible when injecting of Refrigerant the regular amount.
CLOGGED BY DUST	PARTIAL CLOG	Freeze room and Refrigerator don't cool normally.	Flowing sound of Refrigerant is heard and frost forms in inlet only.	A little high more than ambient temperature.	<ul style="list-style-type: none"> • Normal discharging of refrigerant. • The capillary tube is faulty.
	WHOLE CLOG	Freezer room and Refrigerator don't cool.	Flowing sound of Refrigerant is not heard and frost isn't formed.	Equal to ambient temperature.	• Normal discharging of Refrigerant.
MOISTURE CLOG		Cooling operation stops periodically.	Flowing sound of Refrigerant is not heard and frost melts.	Low than ambient temperature	• Cooling operation restarts when heating the inlet of capillary tube.
DEFECTIVE COMPRESSION	COMP-RESSION	Freezer and Refrigerator don't cool.	Low flowing sound of Refrigerant is heard and frost forms in inlet only.	A little high than ambient temperature.	• The pressure of high pressure part in compressor is low.
	NO COMP-RESSION	No compressing operation.	Flowing sound of Refrigerant is not heard and no frost.	Equal to ambient temperature.	• No pressure of high pressure part in the compressor.

▼ Leakage Detection

- Observe discharging point of refrigerant which may be in the oil discharging part in the compressor and hole of evaporator.

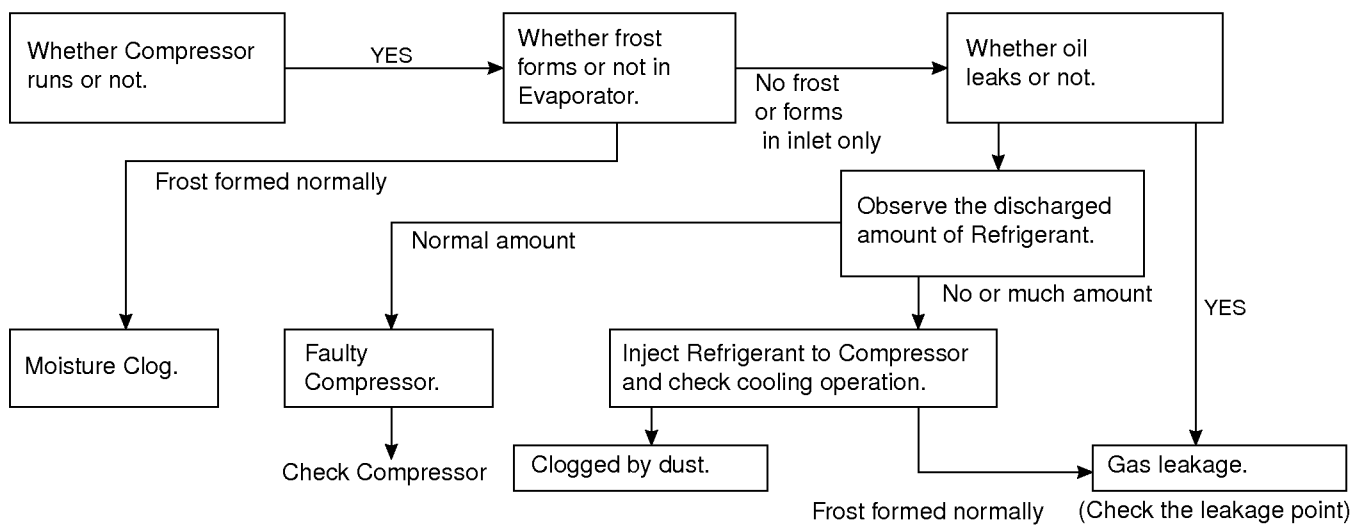

▼ General Control of Refrigerating Cycle

NO.	ITEMS	CONTENTS AND SPECIFICATIONS	REMARKS
1	WELDING ROD	(1) H 30 • Chemical Ingredients Ag: 30%, Cu: 27%, Zn: 23%, Cd: 20% • Brazing Temperature: 710~840°C (2) Bcup-2 • Chemical Ingredients Cu: About 93% P: 6.8~7.5% The rest: within 0.2% • Brazing Temperature: 735~840°C	<ul style="list-style-type: none"> • Recommend H34 containing 34% Ag in the Service Center.
2	FLUX	<ul style="list-style-type: none"> • Ingredients and how to make Borax 30% Borax 35% Fluoridation kalium: 35% Water: 4% Mix the above ingredients and boil until they are transformed into liquid. 	<ul style="list-style-type: none"> • Make amount for only day. Holding period: 1 day • Close the cover of container to prevent dust putting in the FLUX. • Keep it in a stainless steel container.
3	DRIER ASM	(1) Assemble the drier within 30min. after unpacking. (2) Keep the unpacked drier at the temperature of 80~100°C.	<ul style="list-style-type: none"> • Don't keep the drier in a outdoors because humidity damages to it.
4	VACUUM	(1) When measuring with pirant Vacuum gauge the charging M/C, vacuum degree is within 1 Torr. (2) If the vacuum degree of the cycle inside is 10 Torr. below for low pressure and 20 Torr. for high pressure, it says no vacuum leakage state. (3) Vacuum degree of vacuum pump must be 0.05 Torr. below after 5 min. (4) Vacuum degree must be same to the value described item (2) above for more than 20 min.	<ul style="list-style-type: none"> • Apply M/C Vacuum Gauge without fail. • Perform vacuum operation until a proper vacuum degree is built up. • If a proper vacuum degree isn't built up, check the leakage from the Cycle Pipe line part and Quick Coupler Connecting part.
5	DRY AND AIR NITROGEN GAS	(1) The pressure of dry air must be more than 12~16kg/cm ² (2) Temperature must be more than -20~ -70°C. (3) Keep the pressure at 12~6kg/cm ² also when substituting dry air for Nitrogen Gas.	
6	NIPPLE AND COUPLER	(1) Check if gas leaks with soapy water. (2) Replace Quick Coupler in case of leakage.	<ul style="list-style-type: none"> • Check if gas leaks from joint of the Coupler.
7	PIPE	<ul style="list-style-type: none"> • Put all Joint Pipes in a clean box and cover tightly with the lid so that dust or humidity is not inserted. 	

8. EXPLODED VIEW & REPLACEMENT PARTS LIST

- ▼ The parts of refrigerator and the shape of each part are subject to change in different localities.
- ▼ Capacitors and fuse are optional parts.

