

SERVICING PRECAUTIONS

AIR RECHARGING IN COMPRESSOR

Test the refrigeration system connecting it electrically before refilling operation. It is necessary to ascertain the function of the motor-compressor and identify the defects immediately. If defects have been found, empty the old system of possible R-134a residue by breaking off the end of the extension piece at its narrow point. (Figure 1) Replace the filter and any damaged components. Unsolder and pull off the piece remaining inside the service tube and then attach an complete extension with male Hansen and at last, solder it to the same tube again. (Figure 2)

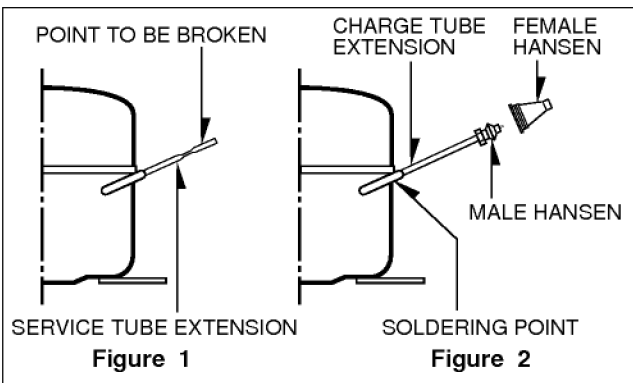

It is necessary to execute the soldering operation with valve open so that the fumes caused by oil residue can come out freely without blowholes between two tubes during the heating the of the point to be soldered. The extension fitted with the male Hansen is connected to the female fitting of the vacuum pump tube. (Figure 3)

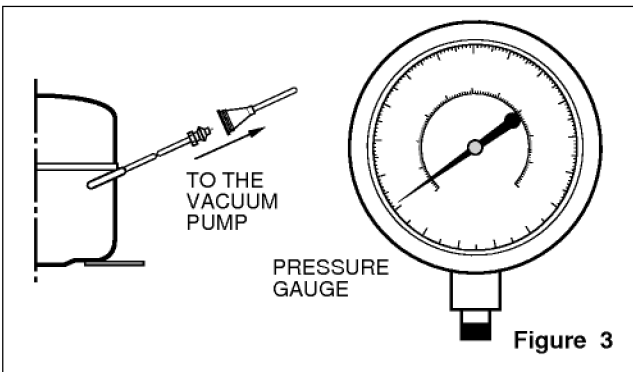

Air evacuating from the system begins as soon as the pump starts. The refrigeration system must be kept under vacuum until the reading on the low-pressure gauge indicates vacuum (0 absolute, -1 atm., -760 mm hg). In any case it is advisable to keep the pump running for about 30 minutes. (Figure 3)

If considerable leakage occurs, it will be necessary to stop the vacuum pump and to add a small quantity of Freon to the system. If vacuum should not be obtained (pressure gauge can't fall to 1 atmosphere), start the refrigeration unit and find the leakage with special leak-finder. When the defective soldering point is visible, repair it after opening the extension tube valve and reestablishing the normal outside pressure inside the group.

Because the melted alloy is sucked into the tubes and blocks them, the pressure must be rebalanced when vacuum is in the system when soldering. As soon as the

vacuum operation is over, add the quantity in grams of R-134a to the refrigeration system. Remember that every system has an exact quantity of R-134a that can be added with a tolerance of ± 5 grams. (Figure 4)

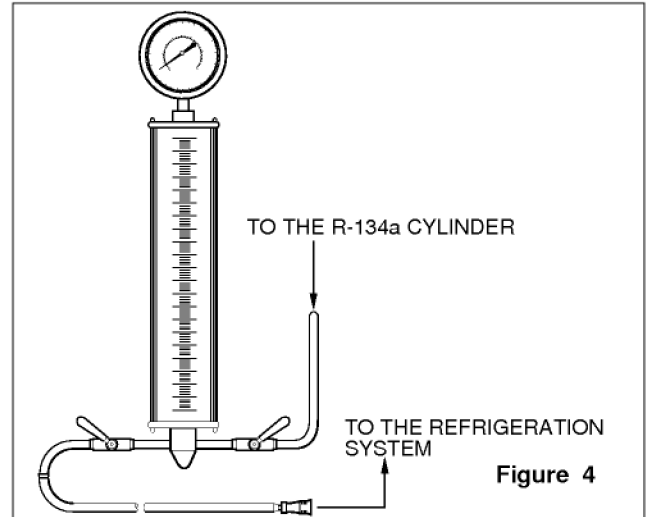

Before performing this operation (if the vacuum pump and refilling cylinder are connected), make sure that the valve placed between the vacuum pump and the refilling tube is closed in order to keep the Freon for addition to the system. (Figure 5)

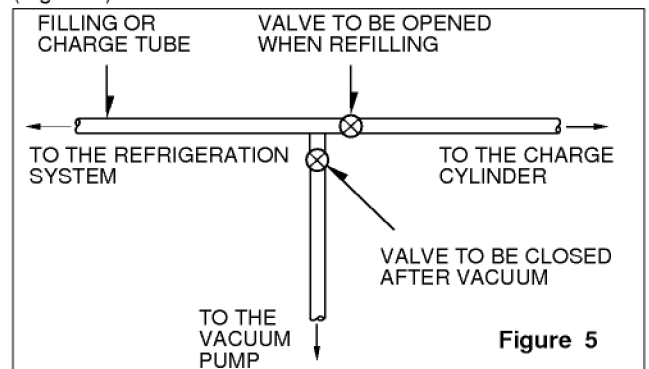

In addition, check the graduated scale on the cylinder for the quantity of R-134a to be added, for example, if we have 750 grams of Freon in the cylinder and must add 140 grams to the group, this amount will be reached when R-134a has dropped to 610 grams, remembering that the indicator shows a lower limit of meniscus. Do this after choosing the scale corresponding to the gas pressure different scales reported as the same gas pressure indicated by the pressure gauge on the top of the column. To make R-134a flow into the system, open the valve placed at the base of the cylinder connected to the filling tube. The amount of Freon cannot be added to the system all at once because it may cause a blocking of motor-compressor. Therefore, proceed by adding the original quantity of about 20-30 grams and close the valve immediately.

The pressure rises and the motor compressor must start sucking the gas and lowering the pressure again. Open the valve again, maintaining the same manner until reaching to the quantity of R-134a established for the system being charged. When the system is running, the suction pressure must be stabilized between 0.30 to 0.6 (0.10 to 0.4) atmosphere.

2. PARTS IDENTIFICATION

FREEZER COMPARTMENT

Freezer Shelf

Automatic Ice Maker

Ice Cube Box

Freezer Temperature Control Dial

REFRIGERATOR COMPARTMENT

Temperature Control Dial

Lamp

Shelves

Egg Box

Snack Corner

Crisper

Used to keep fruits and vegetables fresh and crisp.

Base Grille

Push the grille toward the refrigerator until it snaps into place.

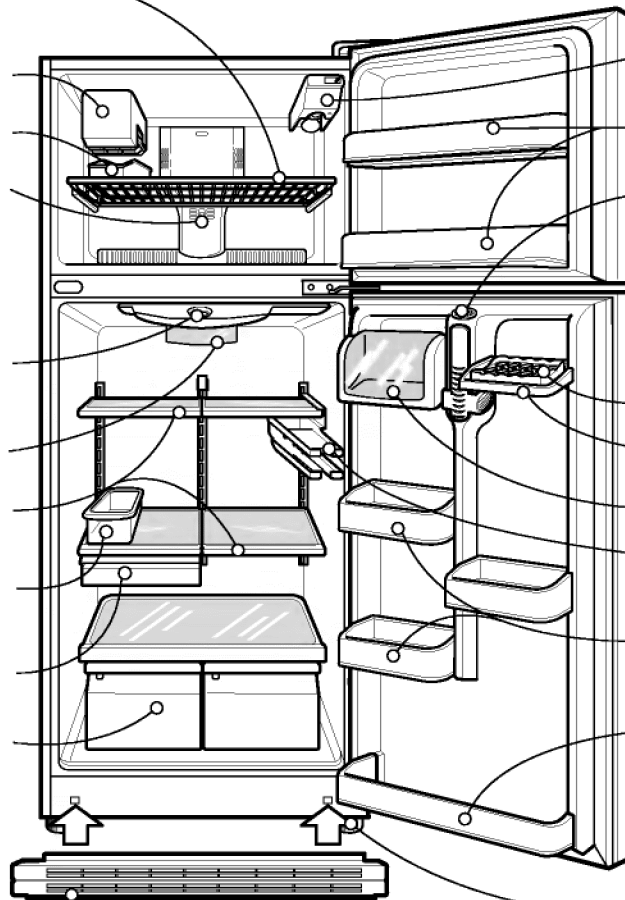

Lamp

Freezer Door Bin

Door Cooling

On the refrigerator door, the cold air passageway is installed to supply cold air to the doorside of the refrigerator compartment.

Egg Tray

Can Server

Dairy Corner

Can Storage

Adjustable Door Bin

Refrigerator Door Rack

Leveling Screw (Inside)

3. DISASSEMBLY

3-1 DOOR

● Freezer Door

1. Remove the hinge cover by pulling it upwards.
2. Loosen hexagonal bolts fixing the upper hinge to the body and lift the freezer door.

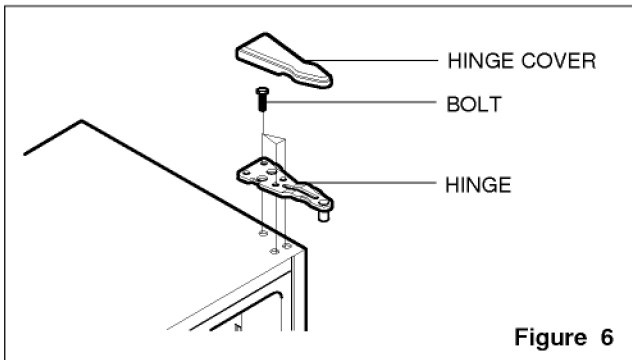

3. Pull out the door gasket to remove from the door foam assembly.

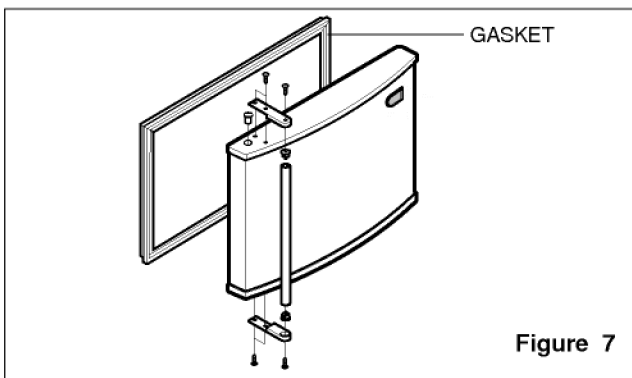

● Refrigerator Door

1. Loosen hexagonal bolts attaching the lower hinge to the body to remove the refrigerator door only.

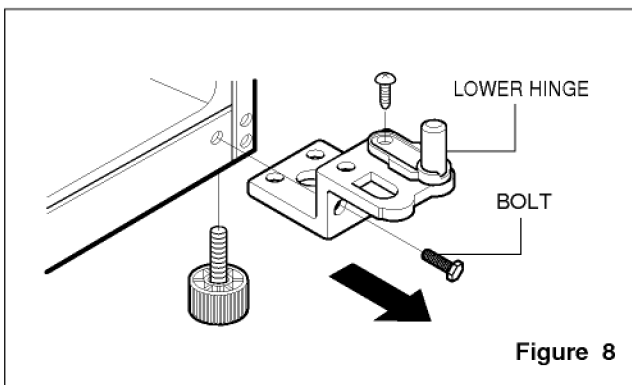

2. Pull out the door gasket to remove from the door foam assembly.

3-2 DOOR SWITCH

1. To remove the door switch, pull out it with a slotted type driver as shown in (figure 9).
2. Disconnect the lead wire from the switch.

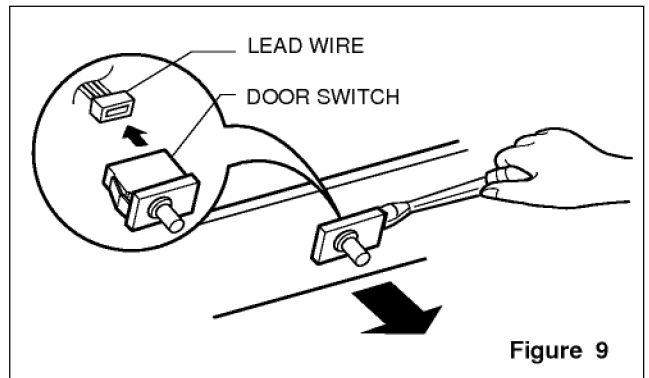

3-3 THERMOSTAT

1. Remove Control Box-R by loosening 2 screws attached to ceiling of Refrigerator compartment (Figure 10)
2. Separate the thermostat and dial knob F.
3. Remove the thermostat by disconnecting the lead wire.

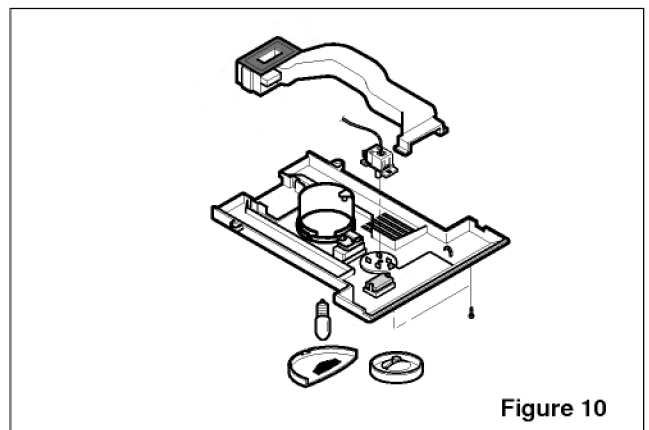

3-4 FAN AND FAN MOTOR

1. Remove the freezer shelf. (If your refrigerator have an Ice Maker, disassemble the Ice maker first)
2. Remove the grille by pulling it out and by loosening a screw.
3. Remove the Fan Motor assembly by loosening 4 screws and disassemble the shroud.
4. Pull out the fan and separate the Fan Motor and Bracket.

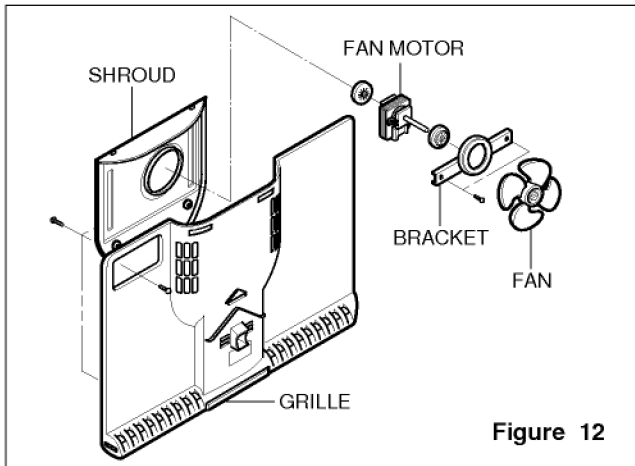

Figure 12

3-5 DEFROST CONTROL ASSEMBLY

Defrost control assembly consists of Defrost Thermostat and FUSE-M.

Defrost Thermostat functions to defrost automatically and it is attached to metal side of the Evaporator and senses Temp.

Fuse-M is a safety device for preventing over-heating of the Heater when defrosting.

At the temperature of 77°C, it stops the emission of heat from the Heater.

1. Pull out the grille assembly.
2. Separate the connector connected with the Defrost Control assembly and replace the Defrost Control assembly after cutting the Tie Wrap. (Figure 14)

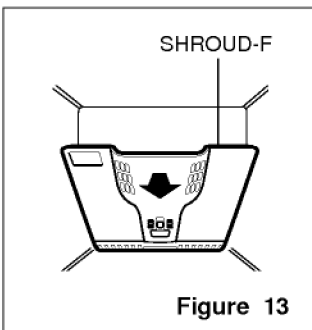

Figure 13

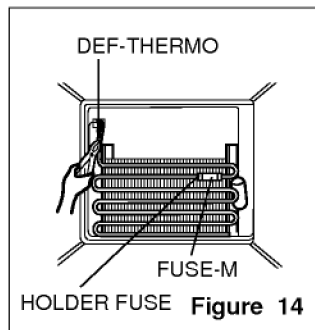

Figure 14

3-6 LAMP

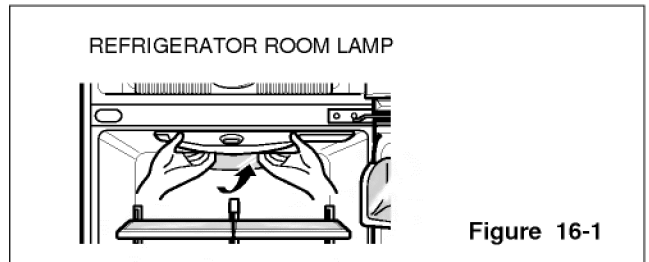

Figure 16-1

3-6-1 Refrigerator room lamp

1. Unplug the power cord from the outlet.
2. Remove refrigerator shelves.
3. Release the hooks on both ends of the lamp shield and pull the shield downward to remove it.
4. Turn the lamp counterclockwise.
5. Assemble in reverse order of disassembly. Replacement bulb must be the same specification as original. (Max 40 W)

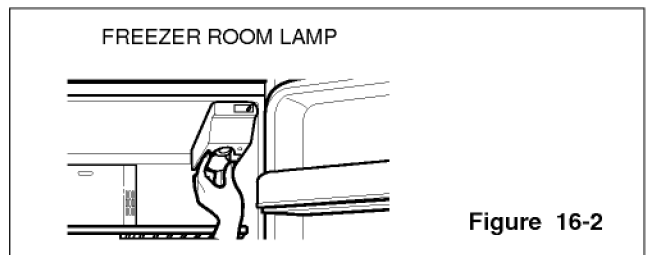

Figure 16-2

3-6-2 Freezer room lamp

1. Unplug refrigerator or disconnect power.
2. Reach behind light shield to remove bulb.
3. Replace bulb with a 25-watt appliance bulb.
4. Plug in refrigerator or reconnect power.

3-7 CONTROL BOX-R

1. First, remove all shelves in the refrigerator and Control Box-R by loosening 2 screws.

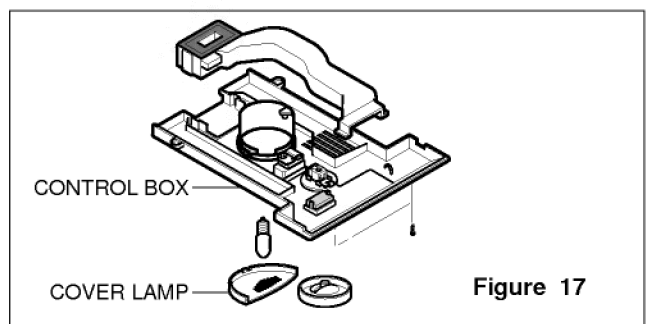

Figure 17

2. Remove the Control Box-R by pulling it downward.
3. Disconnect the lead wire on the right position and separate timer, thermostat, Lamp socket, etc.

4. ADJUSTMENT

4-1 COMPRESSOR

4-1-1 Role

The compressor intakes low temperature and low pressure gas evaporated from evaporator of the refrigerator, and condenses this gas to high temperature and high pressure gas, and then plays delivering role to condenser.

4-1-2 Composition

The compressor includes overload protection. The PTC starter and OLP (overload protector) are outside the compressor. Since the compressor is manufactured to tolerances of 1 micron, and is sealed in a dust - and moisture - free environment, use extreme caution when repairing it.

4-1-3 Note for Usage

- (1) Be careful not to allow over-voltage and over-current.
- (2) No Strike

If applying forcible power or strike (dropping or careless handling), poor operation and noise may occur.

- (3) Use proper electric components appropriate to the Compressor.

- (4) Note to Keep Compressor.

If Compressor gets wet in the rain and rust in the pin of Hermetic Terminal, the result may be poor operation and poor contact may cause.

- (5) Be careful that dust, humidity, and welding flux don't contaminate the compressor inside when replacing the Compressor. Dust, humidity, and flux due to welding which contaminates the cylinder may cause lockage and noise.

4-2 PTC-STARTER

4-2-1 Composition of PTC-Starter

- (1) PTC (Positive Temperature Coefficient) is a no-contact semiconductor starting device which uses ceramic material consisting of BaTiO₃.
- (2) The higher the temperature is, the higher the resistance value. These features are used as starting device for the Motor.

4-2-2 Role of PTC-Starter

- (1) PTC is attached to Hermetic Compressor used for Refrigerator, Show Case, and starting Motor.
- (2) Compressor for household refrigerator applies to single-phase induction Motor.
For normal operation of the single-phase induction motor, in the starting operation flows in both main coil and sub-coil. After the starting is over, the current in subcoil is cut off. The proper features of PTC play all the above roles. So, PTC is used as a motor starting device.

4-2-3 PTC-Applied Circuit Diagram

● According to Starting Method for the Motor

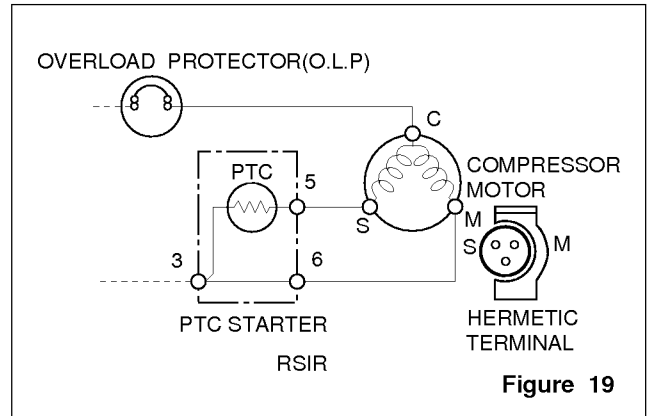

Figure 19

4-2-4 Motor Restarting and PTC Cooling

- (1) For restarting after power off during normal Compressor Motor operation, plug the power cord after 5 min. for pressure balance of Refrigerating Cycle and PTC cooling.
- (2) During normal operation of the Compressor Motor, PTC elements generate heat continuously. Therefore, if PTC isn't cooled for a while after the power has been shut off, the motor will not restart.

4-2-5 Relation of PTC-Starter and OLP

- (1) If the power is off during operation of Compressor and the power is on before the PTC is cooled, (instant shut-off within 2 min. or unplugging and reconnecting), the PTC isn't cooled and a resistance value grows. As a result, current can't flow to the sub-coil, the Motor can't operate, and the OLP operates by flowing over current in only in the main-coil.
- (2) While the OLP repeats on and off operation about 3-5 times, PTC is cooled and Compressor Motor performs normal operation.
If OLP doesn't operate when PTC is not cooled, Compressor Motor is worn away and causes circuit-short and fire. Therefore, always use a properly attached OLP.

4-2-6 Note to Use PTC-Starter

- (1) Be careful not to allow over-voltage and over-current.
- (2) Do not strike
Don't apply a forcible power or strike.
- (3) Keep apart from any liquid.
If liquid, such as oil or water away enters the PTC, PTC materials may fail due to insulation breakdown of the material itself.
- (4) Don't change PTC at your convenience.
Don't disassemble PTC and case. If the exterior to the PTC-starter is damaged, resistance value is altered and it may cause poor starting of the compressor motor may cause.
- (5) Use a properly attached PTC.

4-3 OLP (OVERLOAD PROTECTOR)

4-3-1 Definition of OLP

- (1) OLP (OVERLOAD PROTECTOR) is attached to the Compressor and protects the Motor by cutting the current to the Motor if the temperature rises and activates the bimetal spring in the OLP.
- (2) When over-voltage flows to Compressor motor, the Bimetal works by heating the heater inside the OLP, and the OLP protects Motor by cutting off current which flows to the Compressor Motor.

4-3-2 Role of the OLP

- (1) The OLP is attached to the Hermetic Compressor used for the Refrigerator and prevents the Motor Coil from being started in the Compressor.
- (2) Do not turn the Adjust Screw of the OLP in any way for normal operation of the OLP.
(Composition and connection diagram of OLP)

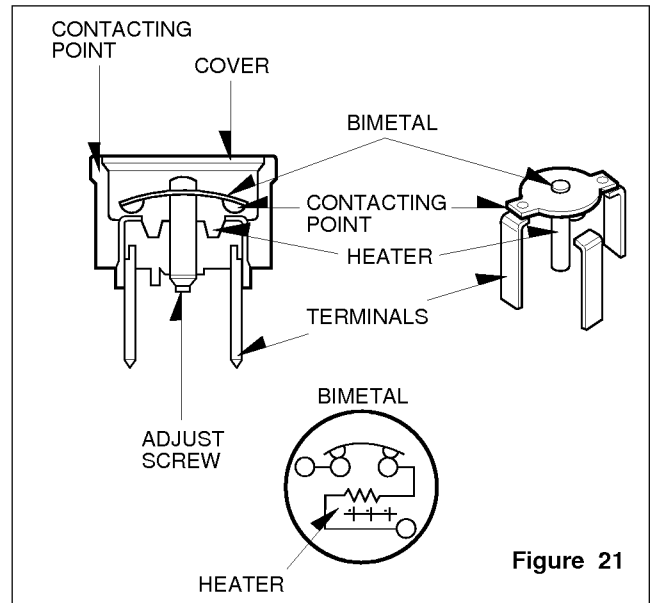
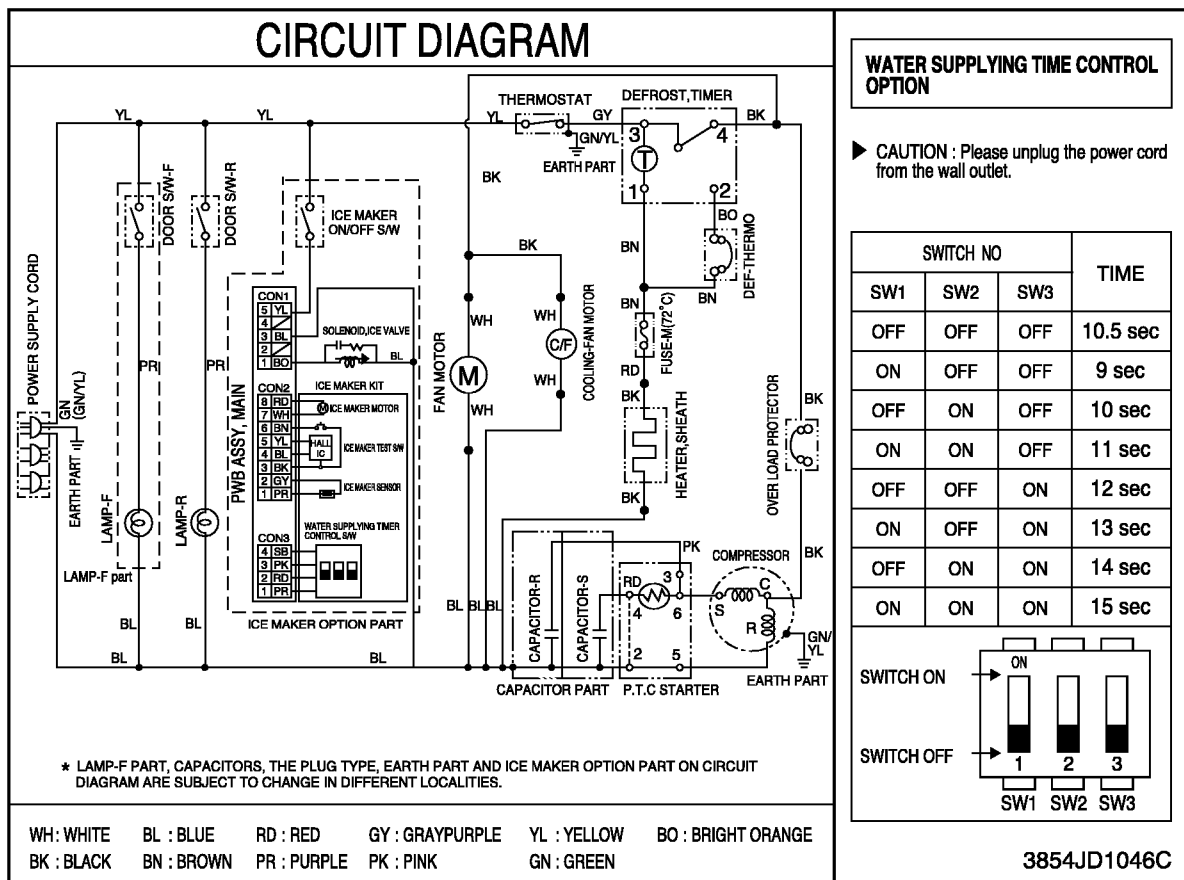

Figure 21

5. CIRCUIT DIAGRAM



6. TROUBLESHOOTING

6-1 COMPRESSOR AND ELECTRIC COMPONENTS

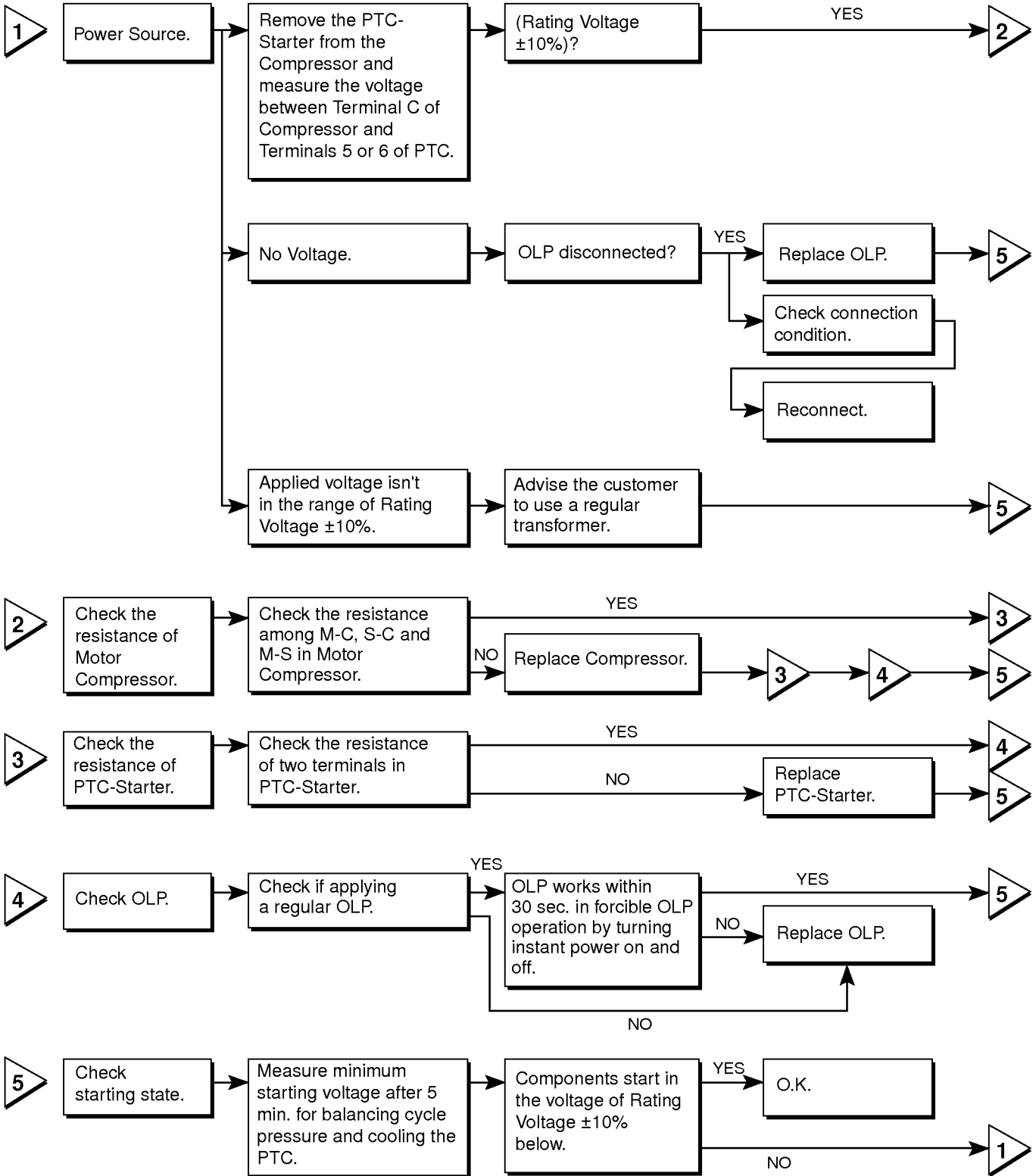

6-2 PTC AND OLP

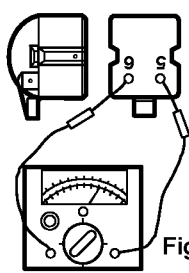
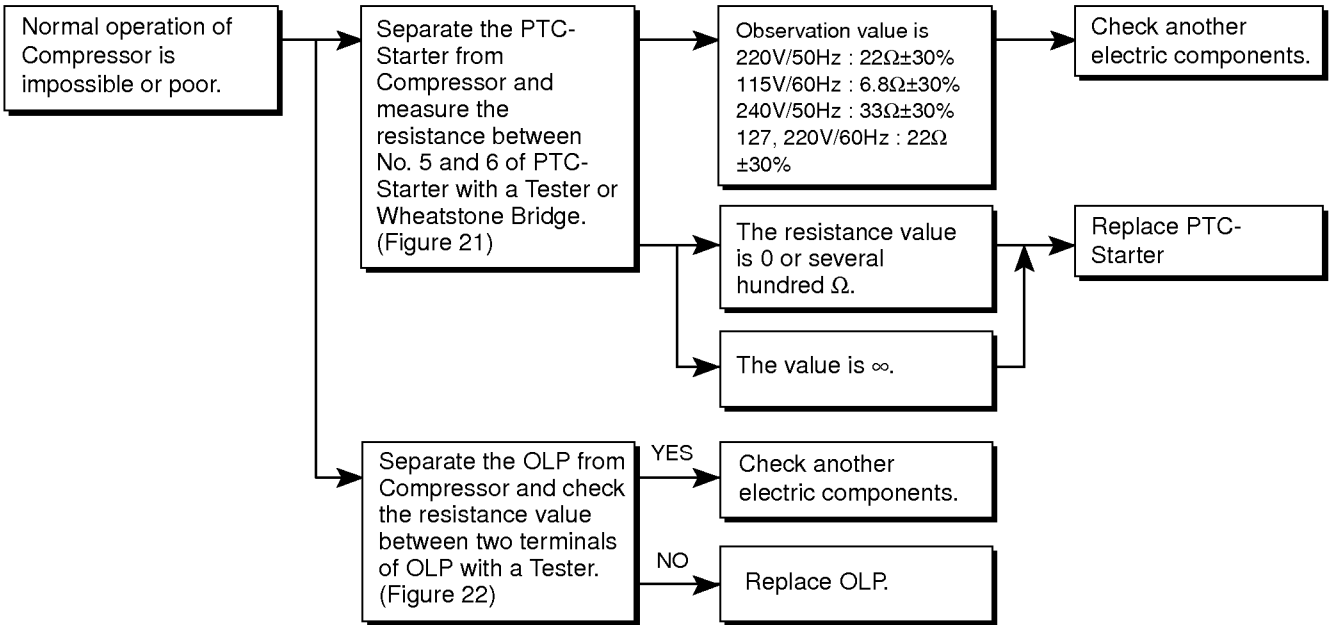

Figure 21

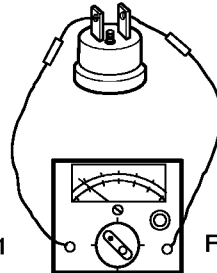

Figure 22

6-3 DEFROST TIMER

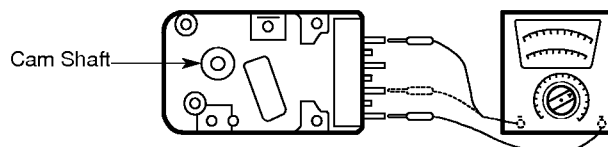
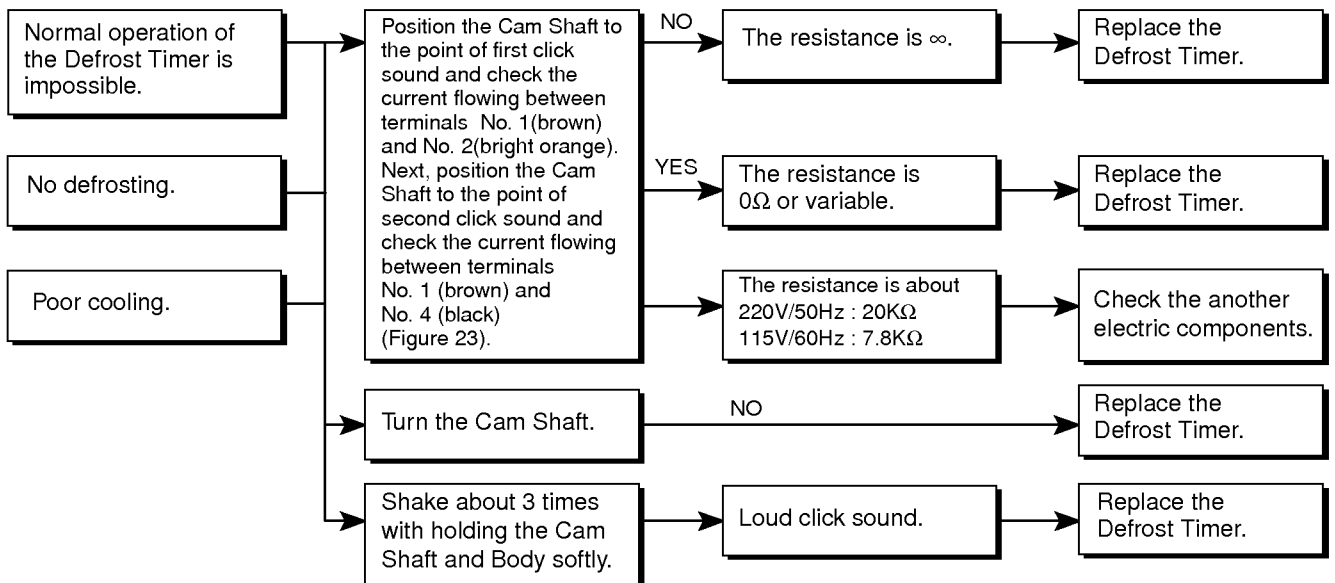
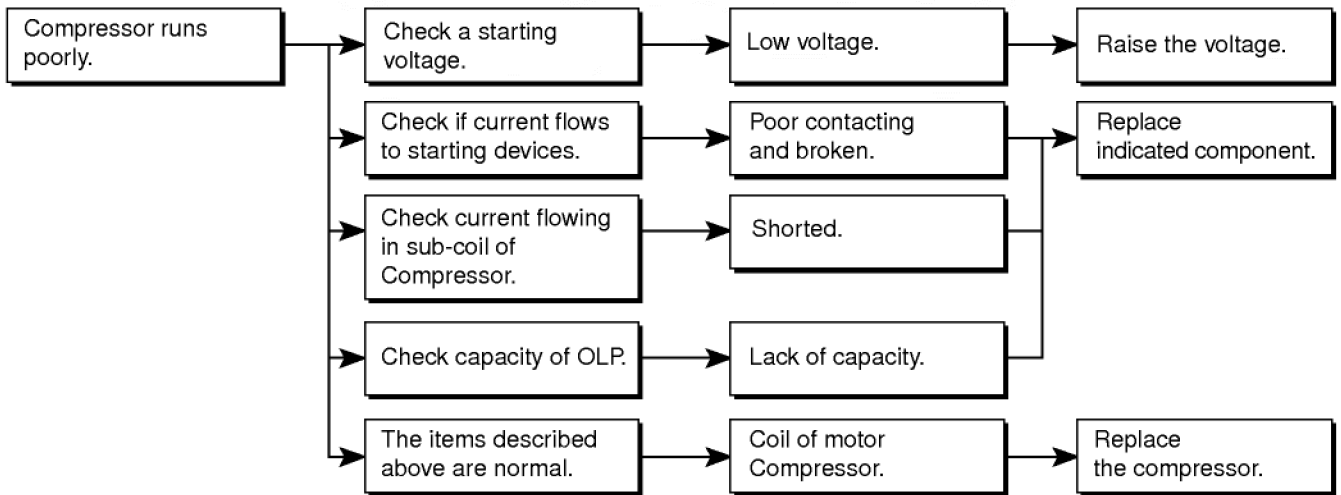
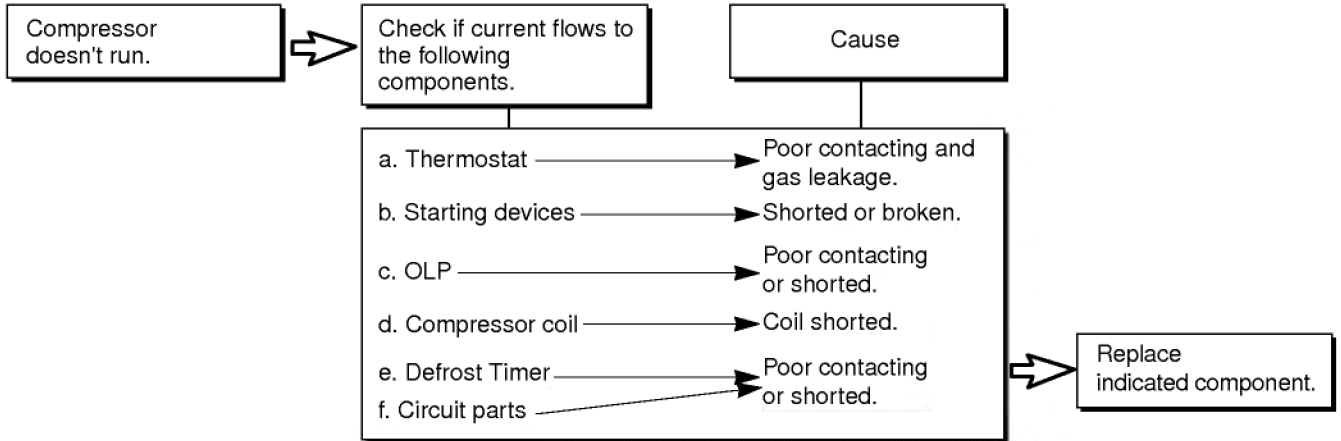

Figure 23

6-4 OTHER ELECTRIC COMPONENTS

▼ Cooling is impossible



▼ Cooling ability is poor

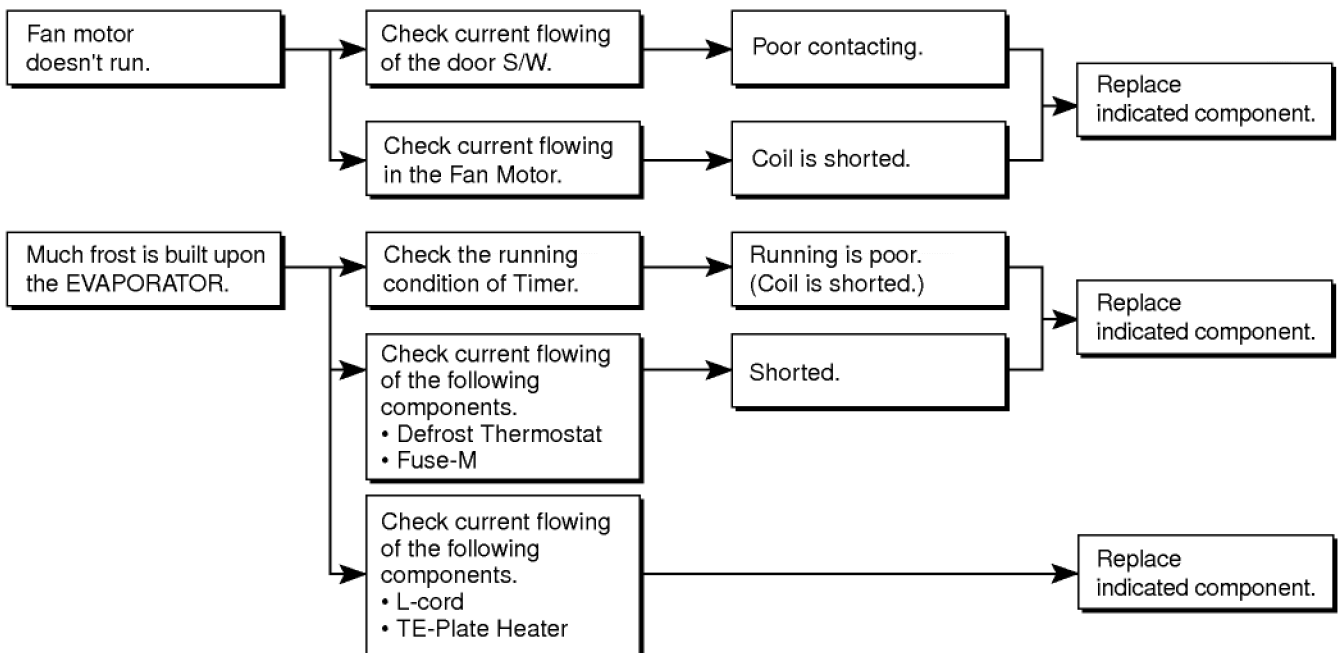

6-4 SERVICE DIAGNOSIS CHART

COMPLAINT	POINTS TO BE CHECKED	REMEDY
Cooling is impossible.	<ul style="list-style-type: none"> Is the power cord unplugged from the outlet? Check if the power S/W is set to OFF. Check if the fuse of power S/W is shorted. Measure the voltage of power outlet. 	<ul style="list-style-type: none"> Plug to the outlet. Set the switch to ON. Replace fuse. If voltage is low, correct wiring.
Cooling ability is poor.	<ul style="list-style-type: none"> Check if the set is placed close to wall. Check if the set is placed close to stove, gas cooker and direct rays. Is the ambient temperature high or the room door closed? Check if put in is hot. Did you open the door of the set too often or check if the door is closed up? Check if the Control is set to WARM. 	<ul style="list-style-type: none"> Place the set with the space of about 10 cm (4 inches). Place the set apart from these heat appliances. Make the ambient temperature below. Put in foods after cooled down. Don't open the door too often and close it firmly. Set the control to mid-position.
Foods in the Refrigerator are frozen.	<ul style="list-style-type: none"> Is food placed in cooling air outlet? Check if the Dial is set to COLD. Is the ambient temperature below 5°C? 	<ul style="list-style-type: none"> Place foods in high temperature section. (Front Part) Set the dial to MID. Set the dial to WARM.
Dew or ice forms inside the set.	<ul style="list-style-type: none"> Is liquid food stored? Check if put in hot. Did you open the door of the set too often or check if the door is closed. 	<ul style="list-style-type: none"> Seal up liquid foods with wrap. Put in foods after cooled down. Don't open the door too often and close it firmly.
Dew forms in the Exterior Case.	<ul style="list-style-type: none"> Check if ambient temperature and humidity of surrounding air are high. Is there gap in the door gasket? 	<ul style="list-style-type: none"> Wipe dew with a dry cloth. This occurrence is solved naturally in low temperature and humidity. Fill up the gap.
Abnormal noise.	<ul style="list-style-type: none"> Is the set positioned in a firm and even place? Are any unnecessary objects set in the back side of the set? Check if the Drip Tray is not firmly fixed. Check if the cover of mechanical room in below and front side is taken out. 	<ul style="list-style-type: none"> Adjust the Adjust Screw, and position in the firm place. Remove the objects. Fix it firmly on the original position. Place the cover at the original position.
Door does not close well.	<ul style="list-style-type: none"> Check if the door packing is dirty with filth such as juice. Is the set positioned in a firm and even place? Is too much food putted in the set? 	<ul style="list-style-type: none"> Clean the door packing. Position in the firm place and level the Adjust Screw. Keep foods not to reach the door.
Ice and foods smell unpleasant.	<ul style="list-style-type: none"> Check if the inside of the set is dirty. Did you keep fragrant foods without wrapping? It smells of plastic. 	<ul style="list-style-type: none"> Clean the inside of the set. Wrap fragrant foods. The new products smells of plastic, but it will go away after 1-2 weeks.

- In addition to the items described left, refer to the followings to solve the complaint.

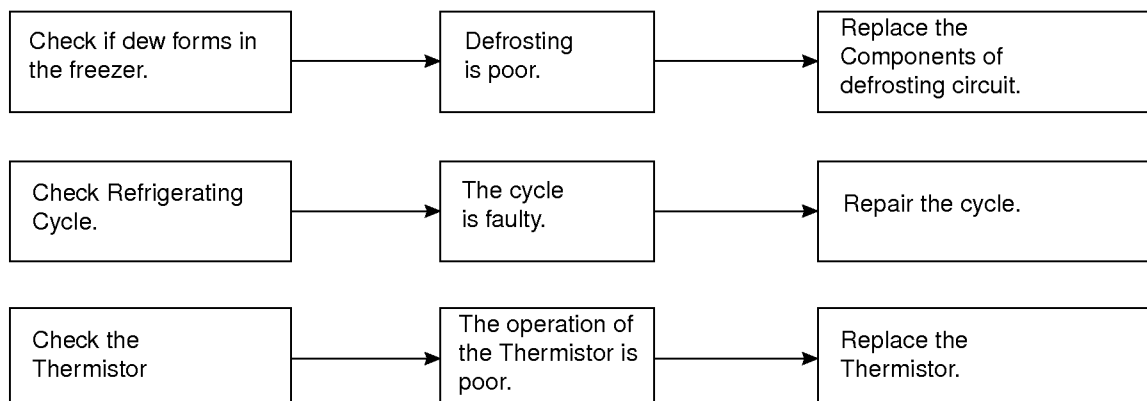

6-5 REFRIGERATING CYCLE

▼ Troubleshooting Chart

CAUSE		STATE OF THE SET	STATE OF THE EVAPORATOR	TEMPERATURE OF THE COMPRESSOR	REMARKS
LEAKAGE	PARTIAL LEAKAGE	Freezer compartment and Refrigerator don't cool normally.	Low flowing sound of Refrigerant is heard and frost forms in inlet only	A little higher than ambient temperature.	<ul style="list-style-type: none"> Refrigerant level is low due to a leak. Normal cooling is possible when injecting of Refrigerant the regular amount.
	WHOLE LEAKAGE	Freezer compartment and Refrigerator don't cool normally.	Flowing sound of refrigerant is not heard and frost isn't formed.	Equal to ambient temperature.	<ul style="list-style-type: none"> No discharging of Refrigerant. Normal cooling is possible when injecting of Refrigerant the regular amount.
CLOGGED BY DUST	PARTIAL CLOG	Freeze compartment and Refrigerator don't cool normally.	Flowing sound of refrigerant is heard and frost forms in inlet only.	A little higher than ambient temperature.	<ul style="list-style-type: none"> Normal discharging of refrigerant. The capillary tube is faulty.
	WHOLE CLOG	Freezer compartment and Refrigerator don't cool.	Flowing sound of refrigerant is not heard and frost isn't formed.	Equal to ambient temperature.	<ul style="list-style-type: none"> Normal discharging of Refrigerant.
MOISTURE CLOG		Cooling operation stops periodically.	Flowing sound of refrigerant is not heard and frost melts.	Lower than ambient temperature	<ul style="list-style-type: none"> Cooling operation restarts when heating the inlet of capillary tube.
DEFECTIVE COMPRESSION	COMP-RESSION	Freezer and Refrigerator don't cool.	Low flowing sound of refrigerant is heard and frost forms in inlet only.	A little higher ambient temperature.	<ul style="list-style-type: none"> Low pressure at high side of compressor due to low refrigerant level.
	NO COMP-RESSION	No compressing operation.	Flowing sound of refrigerant is not heard and no frost.	Equal to ambient temperature.	<ul style="list-style-type: none"> No pressure of high pressure part in the compressor.

▼ Leakage Detection

- Observe discharging point of refrigerant which may be in the oil discharging part in the compressor and hole of evaporator.

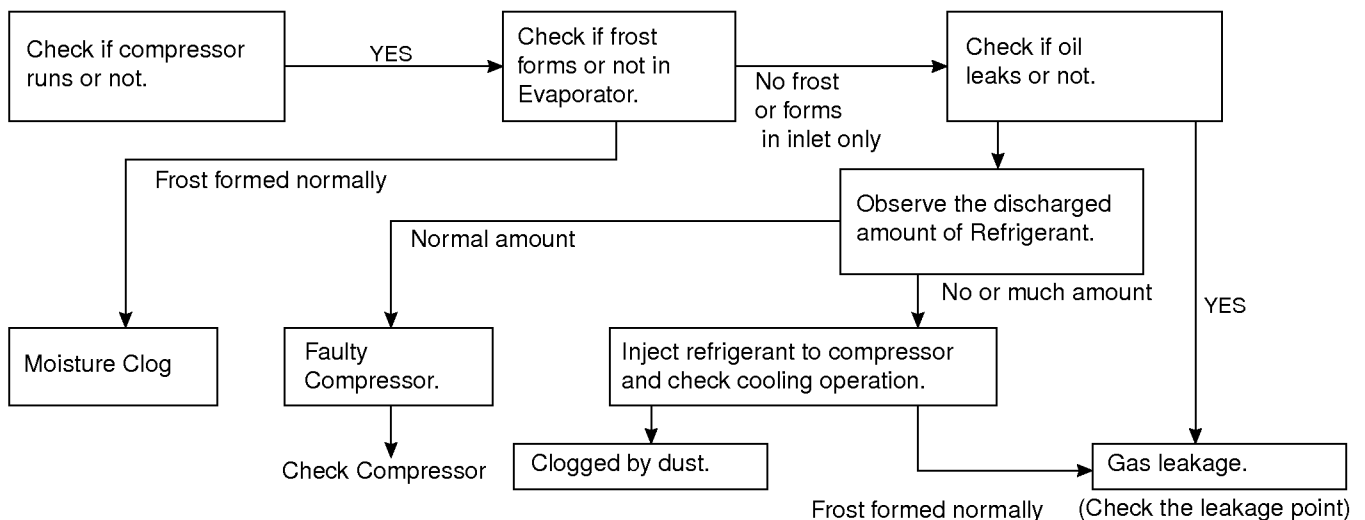

▼ General Control of Refrigerating Cycle

NO.	ITEMS	UNIT	STANDARDS	PURPOSES	REMARKS	
1	Pipe and piping system opening time	Min.	Pipe: within 1 hour. Comp: within 10 minutes. Drier: within 20 minutes.	To protect moisture penetration.	The opening time should be reduced to a half of the standards during rain and rainy seasons (the penetration of water into the pipe is dangerous).	
2	Welding	Nitrogen pressure	Weld under Nitrogen atmosphere. (N ₂ pressure: 0.1~0.2 kg/cm ²)	To protect oxide scale formation.	- Refer to repair note in each part. - R-134a refrigerant is more susceptible to leaks than R-12 and requires more care during welding. - Do not apply force to pipes before and after welding to protect pipe from cracking.	
3	N ₂ sealed parts	Confirm N ₂ leak	Confirm air leaking sounds when removing rubber cap. Sound: usable No sound: not usable	To protect moisture penetration.	- In case of evaporator parts, if it doesn't make sound when removing rubber cap, blow dry air or N ₂ gas for more than 1 min and use the parts.	
4	Refrigeration Cycle	Evacuation time	Min.	More than 40 minutes	To remove moisture.	
		Vacuum degree	Torr	Below 0.03 (ref)		Note: Only applicable to the model equipped with reverse flow protect plate.
		Vacuum	EA	High and low pressure sides are evacuated at the same time for models above 200 l.		Vacuum efficiency can be improved by operating compressor during evacuation.
		Vacuum piping	EA	Use R-134a exclusive manifold.	To protect mixing of mineral and ester oils.	The rubber pipes for R-12 refrigerant shall be melted when they are used for R-134a refrigerant (causes of leak.)
		Pipe coupler	EA	Use R-134a exclusive.	To protect R-12 refrigerant mixing.	
		Outlet (Socket)		R-134a exclusive.	"	
		Plug		R-134a exclusive.	"	
5	Refrigerant weighing	EA	Use R-134a exclusively. Weighing allowance: ±5g Note: Winter: -5g Summer: +5g	Do not mix with R-12 refrigerant.	- Do not weigh the refrigerant at too hot or too cold an area. (77°F[25°C] is adequate.) - Make Copper bombe (Device filling refrigerant) Socket: 2SV Plug: 2PV R-134a Note: Do not burn O-ring (bushing) during welding.	
6	Drier replacement		- Use R-134a exclusively for R-134a refrigerator. - Use R-12 exclusively for R-12 refrigerator. - Replace drier whenever repairing refrigerator cycle piping.	To remove the moisture from pipe inside.		
7	Leak check		- Do not use soapy water for check. It may be sucked into the pipe by vacuum.	Defect refrigerant leak area.	- Check oil leak at refrigerant leak area. Use electronic leak detector if oil leak is not found. - The electronic leak detector is very sensitive to halogen gas in the air. It also can detect R-141b in urethane. Practice many times before using this type of detector.	

7. OPERATION PRINCIPLE AND REPAIR METHOD OF ICE MAKER

This manual describes function of models adhering Ice Maker.

7-1 OPERATION PRINCIPLE

7-1-1 Operation principle of Ice Maker

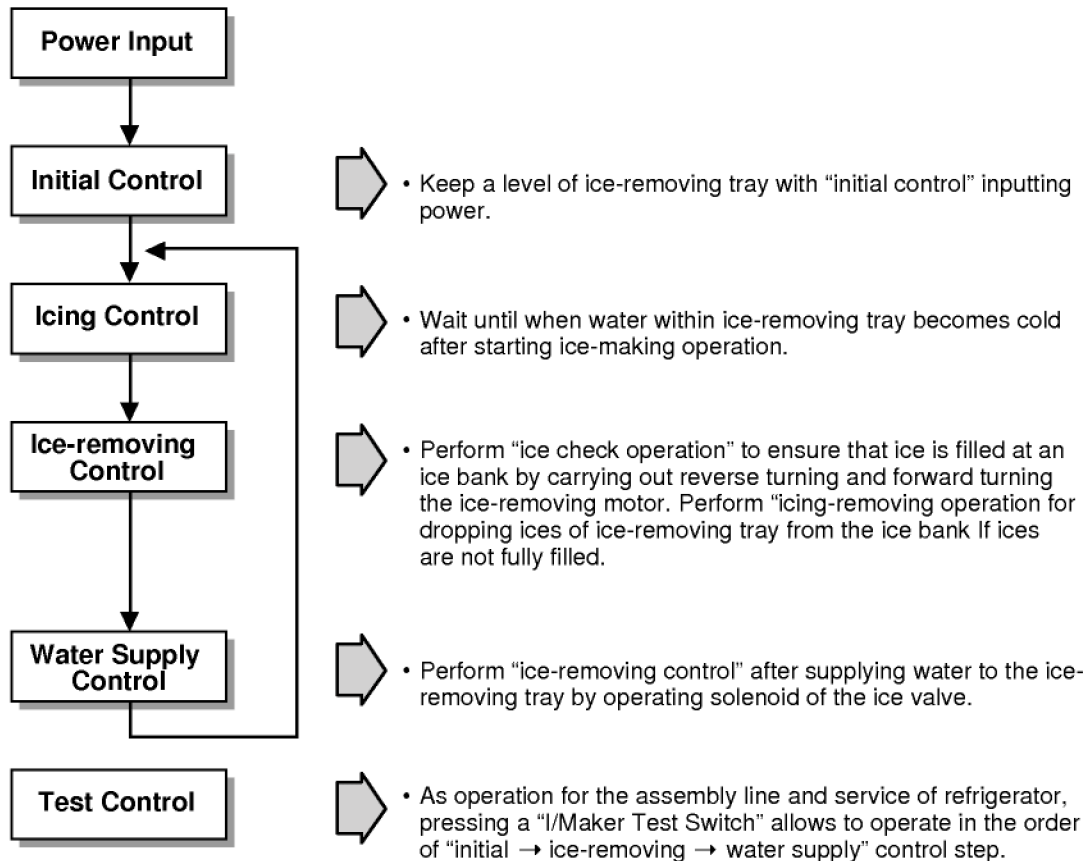

1. Turning the ice-making stop switch off stops ice-making function of the ice-maker and thus no ice is made .
2. Ice-making function stops at the time of selecting ice-making function and release of the ice-making function allows to perform the initial control function again.

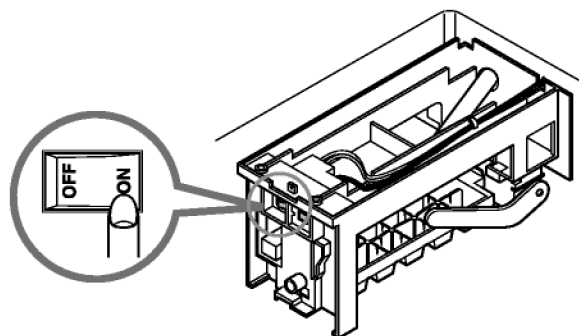

* Make sure the switch on the ice maker assy is turned "on".

7-2 Function of Ice maker

7-2-1 Initial control function

1. The level of the ice-removing tray (ice-removing container) after completing the MICOM initialization in the initial POWER ON, returning to electricity failure and turning-off of ice-making stop switches. Namely, detection lever operates up and down.
2. The level of ice-removing container is detected with high / low output signal of hall sensor.
In another words, operation is performed in order to keep a level by operating ice-removing motor so that high or low voltage could be applied in the MICOM PIN.
3. No signal change of hall sensors until a minute after operating the ice-removing motor should be considered as failure. In this case, stop the automatic ice-remover and then reset the ice-maker initialization if considered as normal after performing continuous check in a cycle of an hour.
4. Keeping of the ice-removing tray (ice-removing container) should be considered initial control is completed.

7-2-2 Water supply control function

1. Supply water into the ice-removing tray by operating the ice solenoid placed at the machine room of refrigerator using the time check function if considered as the level is kept after performing a horizontal operation of the ice-making tray after the ice-removing control (normal ice-removing control, ice-removing control of test function) is completed.
2. The quantity of water supply is determined by supplying water for a constant using the dip switch.

<Water Supply Quantity Table>

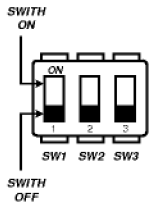
				SWITCH NO	TIME	Remarks
				SW1	SW2	
	OFF	OFF	OFF	10.5 sec	The quantity of water supply may differ depending on the setting status of the dip switch or on water pressure as water supply method is of a pattern of direct connection to water cock.	
	ON	OFF	OFF	9 sec		
	OFF	ON	OFF	10 sec		
	ON	ON	OFF	11 sec		
	OFF	OFF	ON	12 sec		
	ON	OFF	ON	13 sec		
	OFF	ON	ON	14 sec		
	ON	ON	ON	15 sec		

3. The change of the quantity of water supply setting may be done according to the changed time even after changing it without powering off. In the change of dip switch during water supply, it is done according to the water supply time previously established and then done according to the additionally changed time from the next water supply.

Water supply control switch

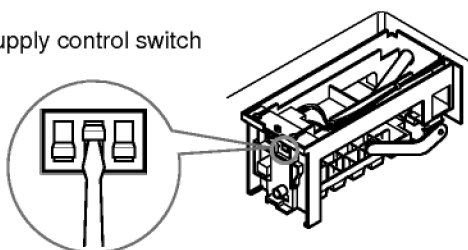

* Adjust the water supply control switch to adjust the amount of water being supplied.

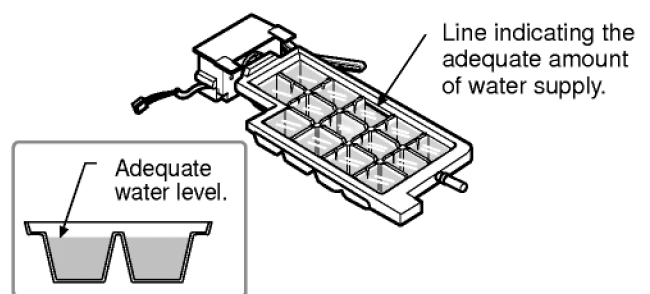

* Make sure it is adjusted to meet the line indicating the adequate amount of water supply.

7-2-3 Ice-making control function

1. Ice-making control is related with when considered as water within ice-making tray (ice container) turns into ice completely after completing water supply operation and performs ice-making completion operation by detecting temperature of ice-making tray. (ice-making sensor is mounted on the bottom of the ice-making tray).
2. Ice-making control begins after completing water supply control or initial control.
3. It is considered that ice-making is completed if temperature of ice-making sensor arrives at -6°C after 60 minutes pass from the time water is supplied to the ice-making tray.
4. It is considered that ice-making is completed if temperature of ice-making sensor arrives at below -7°C after 10 minutes pass at the above status.

7-2-4 Ice-removing control function

- Ice-removing control means operation to separate ice within ice-making tray (ice-making container) after ice-making is completed.
- Step to check ices stored at the ice bank (container for storing ice) are fully filled. It is considered as they are fully filled if signals of the hall sensor are at the On status ("high") before 3.6seconds after rotating positively the ice-making motor. In this case, the ice-making motor remains at the waiting status without performing ice-removing function. Perform ice-detecting operation after rotating positively the ice-making motor in the cycle of an hour if the full ice status is detected. Perform water supply control function after completing ice-removing function in the short of ices stored. Reversely rotating the ice-removing motor in the storage of full ices and then let the motor stop at the position of the ice-making or waiting status.
- Ice-removing control performs ice-removing operation immediately if ices stored at the ice bank (container for storing ice) are not fully filled (the hall sensor are at the Off status ("low") within 3.6seconds after rotating positively the ice-making motor). In this case, it positively rotates (CW) the ice-removing motor and keeps the ice-making tray at the maximum distortion status and makes ices be separated from the ice-making tray. In this case, ice-detecting lever automatically operates lifting operation with ice-removing operation.
- Ice-removing control positively rotates (CW) the ice-removing motor and stops it for a second as it considers as maximum distortion point (ice-detecting axle = 160°) if the sensor signal changes from the Off status ("low") to the On status ("high") after 3.6 seconds pass.
- Ice-removing control positively rotates (CW) the ice-removing motor at the cycle of an hour if problems in ice-making motor or hall sensor are found and performs initial operation or operates initialization of product if normal.
- Ice-removing control stops for a second at the maximum distortion status of the ice-removing tray (container for storing ice).
- Step that the ice-removing tray stops for a second and then returns to the level. It returns to the level status returns to the ice-removing tray by reversely rotating the ice-making motor.
- The cycle of "water supply → ice-making → ice-removing → returning to the level" if becoming the level status.

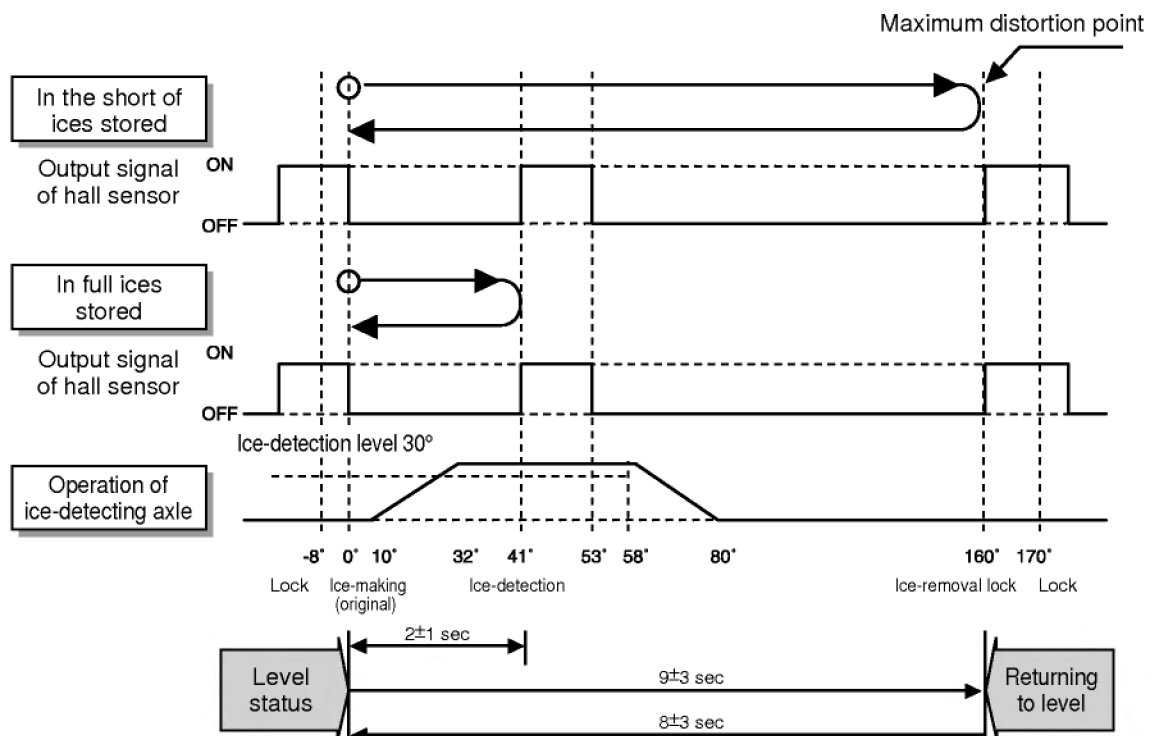

<Timing chart for ice-removal>

7-2-5 Test Function

1. Function used compulsory operation for the purpose of performing operation test, service and cleaning. This test function is performed if pressing the test switch mounted on the automatic ice-maker itself for 0.5 second or more.
2. The test button operates when the test function is not input but at the level status. It does not perform ice-removal control and water supply control if ices are full during operation of test function
3. Pressing the test button for more than 0.5 seconds at the level the status immediately performs ice-removing operation irrespective of the ice generation conditions of the ice-making tray.
Caution shall be exercised as water may overflow if operating the test function at the water status that ice-making is not done. A cycle of water supply is performed at the level adjusting operation after ice-removing operation.
Therefore, the test button allows to check problems in ice-removing operation, level operation and water supply.
4. The test function operates in the normal cycle of ice-making → ice-removal → returning to the level → water supply if water supply is completed.

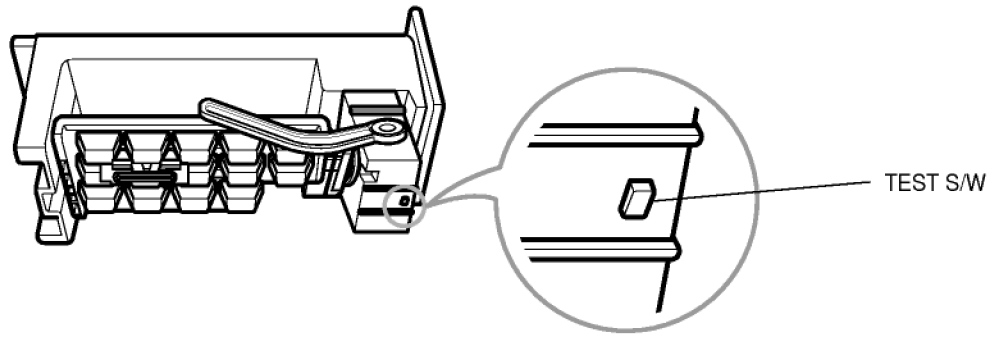

* To check on the amount of water being supplied, press the Test button. (Hold for 0.5 seconds)

7-3 Failure diagnosis method of ice maker

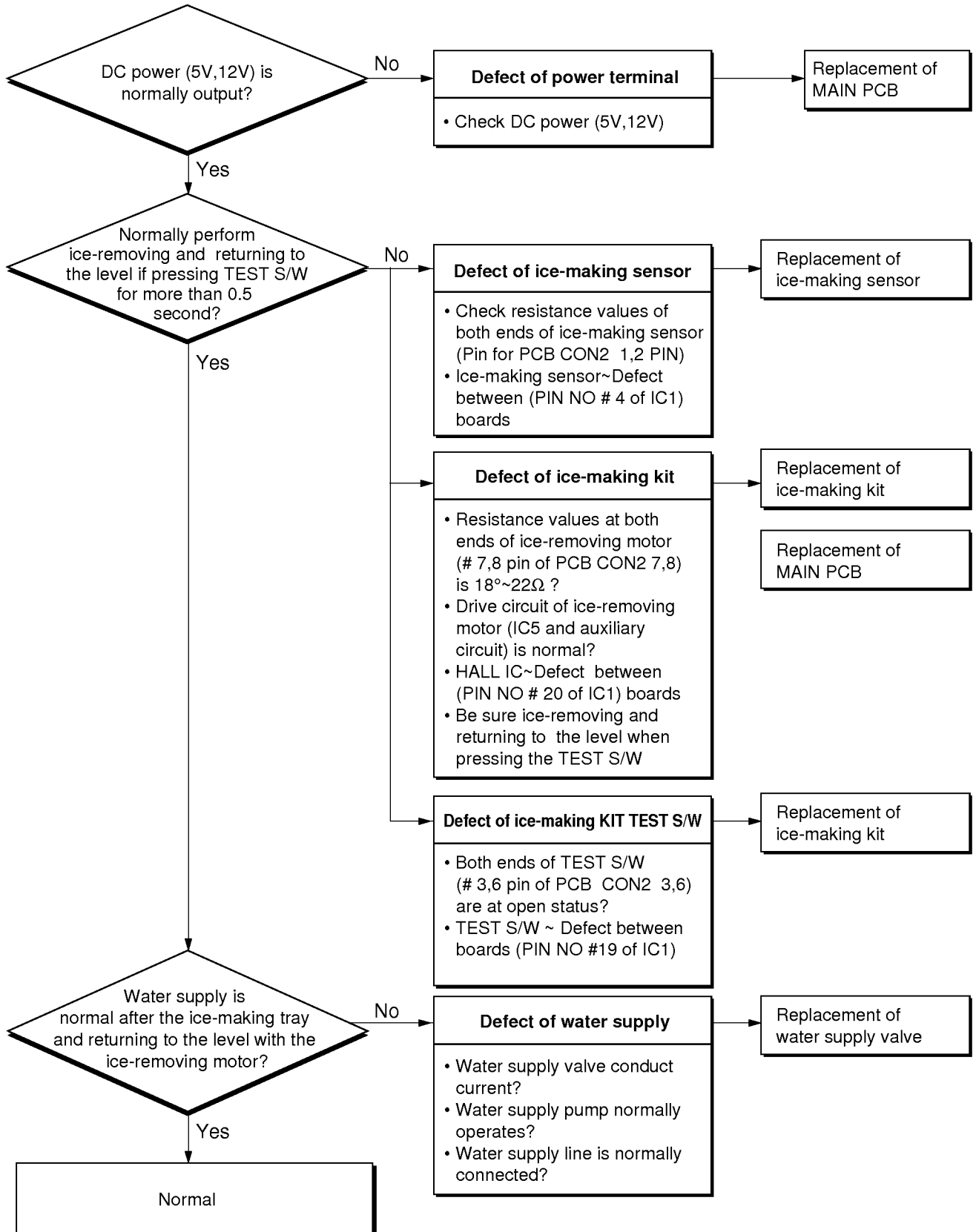

7-4 Explanation of ice maker circuits

7-4-1 Power circuit

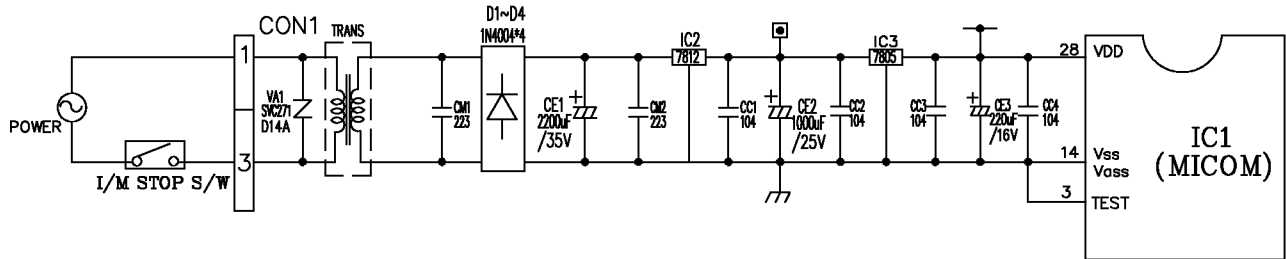

The secondary party of transformer consists of power (12Vdc) for driving display and relay and power (5Vdc) supplying power to MICOM and IC.

In this case, voltage at each part is as follows:

Part	Both ends of VA1	Both ends of CE2	Both ends of CE3
Voltage	115Vac	12Vdc	5Vdc

VA1 is parts for preventing over-voltage and noise and plays a role of protecting elements of the secondary part of transformer as the inside of element becomes short and is broken and power fuse is cut off when power of more than 175V is applied.

7-4-2 Vibration circuit

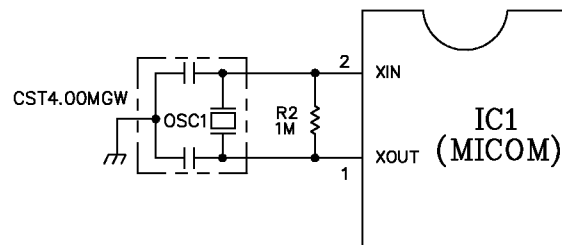

Circuit used for synchronous clock generation for transmitting/receiving information of the inside logic elements of IC and basic time generation for calculating time. Rated parts must be used as counting time is changed at the IC1 or the OSC1 does not operate if SPEC would be changed.

7-4-3 Reset circuit

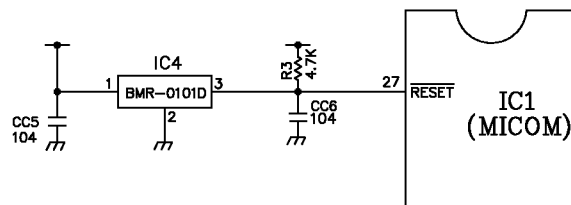

The reset circuit is a circuit that initializes various parts such as RAM, etc inside of the MICOM (IC1) and starts the whole of function from the initial status and 'low' voltage is applied for a constant time (10ms) at the reset terminal of the MICOM at the start of power input.

The reset terminal is at 5V during general operation (the MICOM does not operate in the defect of the reset IC).

7-4-4 Load drive circuit

1. Load drive status check

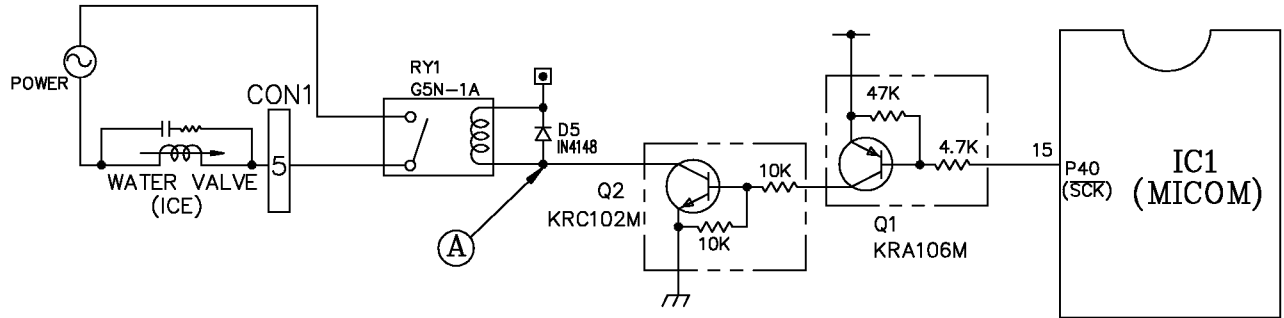

Load Type		Water Valve
Measurement Location		(A)
Condition	ON	1V below
	OFF	12V

7-5 Main PWB Assembly and Parts List

7-5-1 MAIN PWB

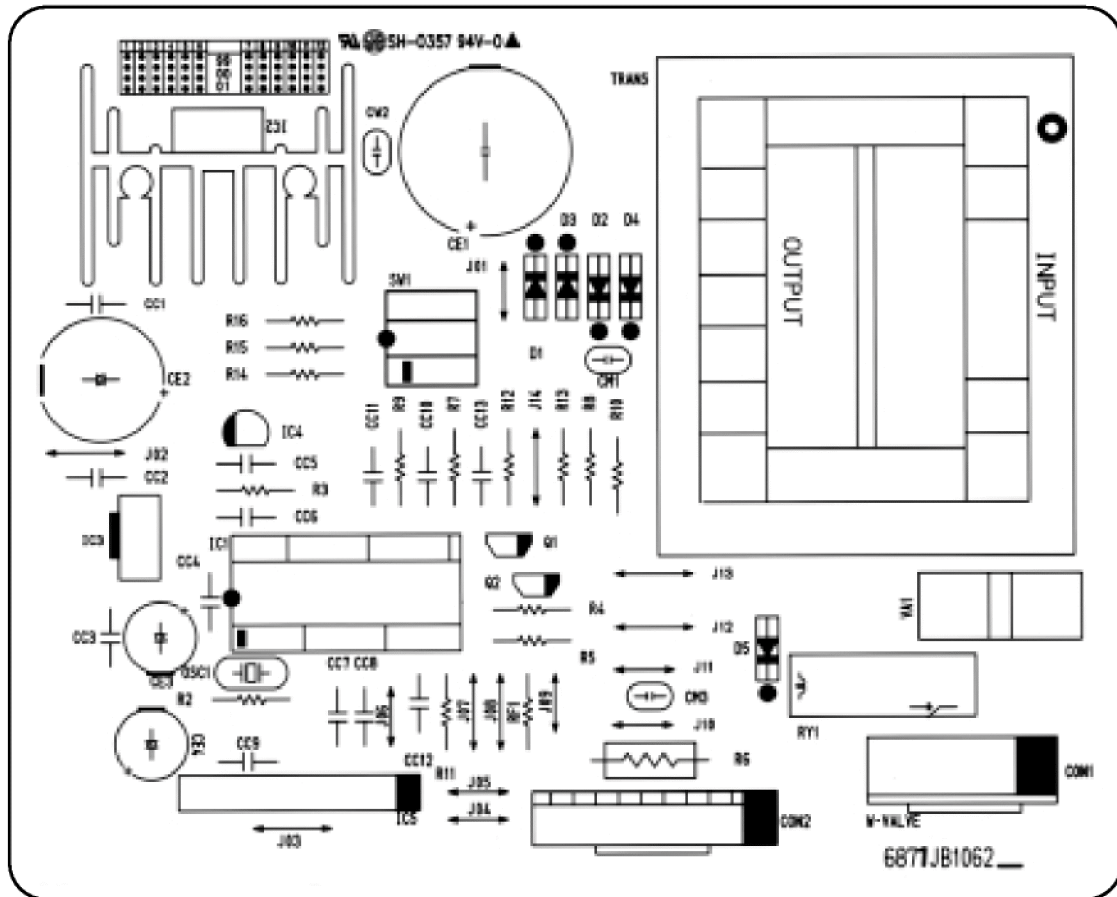

7-5-2 Replacement Part List

NO.	DWG. NO.	DESCRIPTION	SPEC	MAKER	REMARK
1	6870JB2039	PWB,MAIN	FR-1(DS-1107A)	DOO SAN	t=1.6
2	6170JB2002	TRANS PCB	I:117V,O:15V	TAE SUNG	TRANS
3	6630JB8001B	WAFER	Æ202-1T-03(5P-24)	JAE EUN	CON1
4	6630JB8004G		SMW250-0B		CON2
5	6630JB8004D		SMW250-04	YEON HO	CON3
6	6630JB8004D				
7	01ZZJB2004A	MICOM CHIP	TMP87C409N	TOSHIBA	IC1(=01ZZJB2004B)
8	01RH178050B	REGULATOR	(1)BA17805T	ROHM	IC3
	01KE780500A		(2)KIA78S05P	KEC	
9	01RH178120A	REGULATOR	(1)BA17812T	ROHM	IC2
	01NE781200B		uPC7812AHF	NEC	
10	01KE704200A	RESET IC	K1A7042P	K.E.C	IC4
	01KD010100A		BMR-0101D	KODENSHI	
11	6920JB2003A	RELAY	G5N-1	OMRON	RY1
12	J570-00012A	RESONATOR	CST4.00MGW	MURATA	OSC1 (=6212A08002B)
	J570-00012B		CST4.00MGW-TF01		
13	J572-00001C (=6102A09075A)	VARISTOR	(1)INR14D471	L JIN	VA1
14	6102JB8001B		(2)SVC471D-14A	SAMHWA	
15	6102JB8001A		(1)INR14D621	L JIN	
16	J572-00001D		(2)SVC621D-14A	SAMHWA	
	6102JB8003A		(1)SVC271D-14A	SAMHWA	
			(2)INR14D271	IL JIN	
17	00D414809BB	SWITCHING DIODE	1N4148	(1)P C (2)ROHM	D5
18	00D400409CC	DIODE,RECTIFIER	1N4004	(1)P C (2)ROHM	D1~D4
19	6800JB8003A	DIP S/W	3P,DIP	OTAX	SW1
20	01RH622200A	DRIVE IC	BA6222	ROHM	IC5
21	0CE2286J618	ELF CAPACITOR	2200uF/35V		CE1
22	0CE1081H618		1000uF/25V		CE2
23	0CE1071H638		100uF/25V	(1)SAM HWA	CE4
24	0CE4771H618		470uF/25V	(2)SAM YOUNG	
25	0CE2271F638		220uF/16V		CE3
26	0CE4761H638		47uF/25V		
27	0CQ2231N409		MYL' CAPACITOR	223/100V	SEIL
28	0CK1020H908	CER' CAPACITOR	102/25V		
29	0CK2230H908		223/25V	TAE YANG	
30	0CK1040H908		104/50V		CC1~12
31					
32	0RD0682H609	R,CARBON FILM	68J 1/2W		R6
33	0RD2001G608		2KJ 1/4W	(1)JO YANG	R7,R9~11
	0RD4701G609		4.7K 1/4W	(2)K-OHM (3)DONG HO (4)SUNG YO	R3~5,8 R14~16
35	0RD1004G608		1M.J 1/4W		R2
36	0RV1612G408		R,METAL FILM	16.2KF 1/4W	
37					
38					
39	0TR106009AC	TRANSISTOR	KRA106M(KRA2206)	K.E.C	Q1
40	0TR102009AB	TRANSISTOR	KRC102M(KRC1202)	K.E.C	Q2
41	43607015	JUMP WIRE	0.6*5mm		J01,J04~J06 J09~J11,CC13 J02,J03,J07, J08,J12~J14
			0.6*8mm		
			0.6*10mm		
			0.6*12.5mm		
			0.6*15mm		
42	4920JB3003A	HEAT SINK(12V)	(=J572-00004A)		(IC2)
43	4920JB3001A	HEAT SINK(5V)	(=J572-00002A)		
44	1SBF0302418	SCREW	ASSEMBLE WITH H/SINK		
45	49111001	SOLDER	ALMIT KR-19RMA	HEE SUNG SOLD'	
46	49111004	SOLDER LEAD BAR	H63A		
47	59333105	FLUX AUTO	JS71	KOKI	
48					

