

EXPLODED VIEW

INTRODUCTION

JES1451

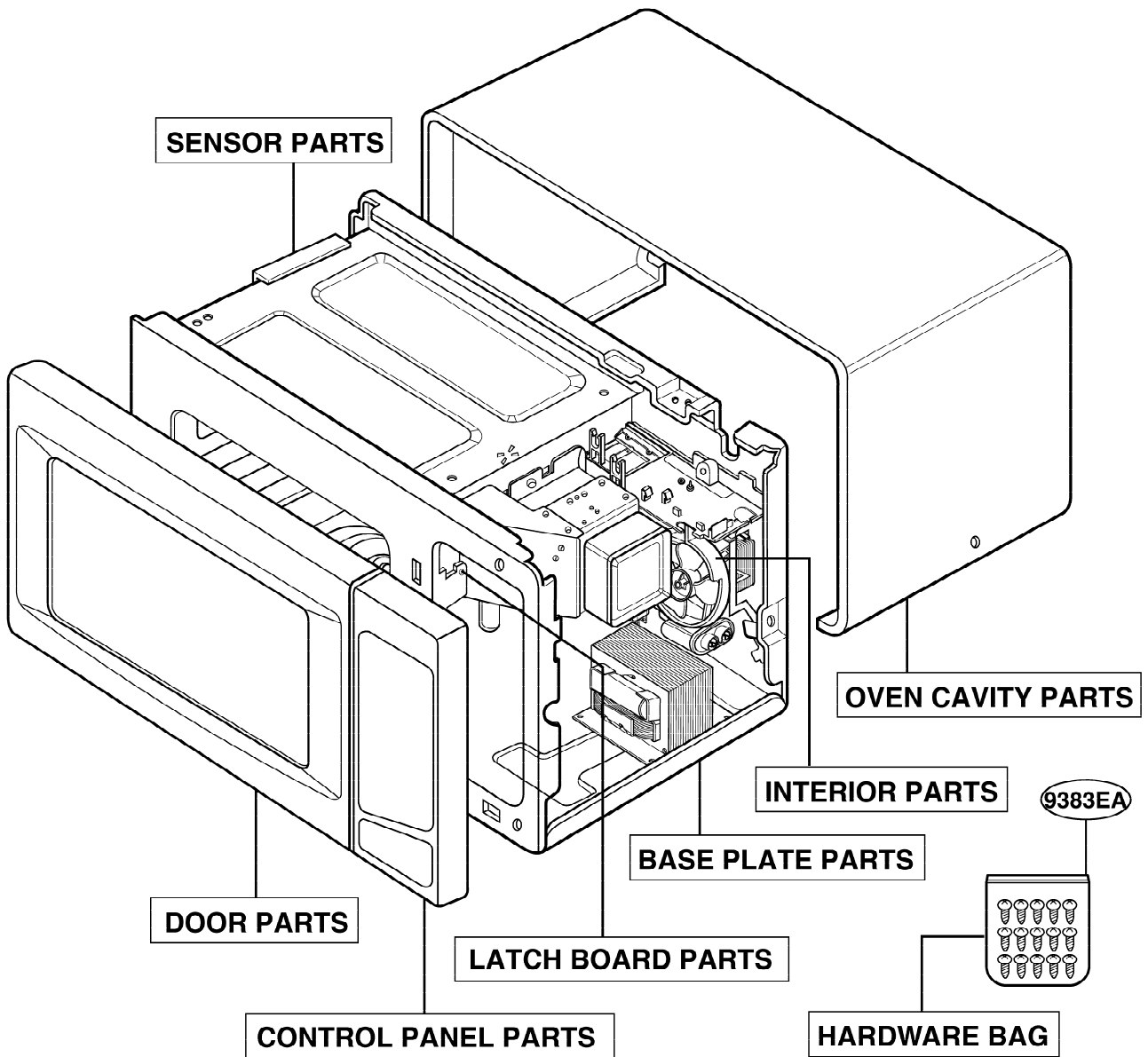

P/NO: 3828W5S4092

DOOR PARTS

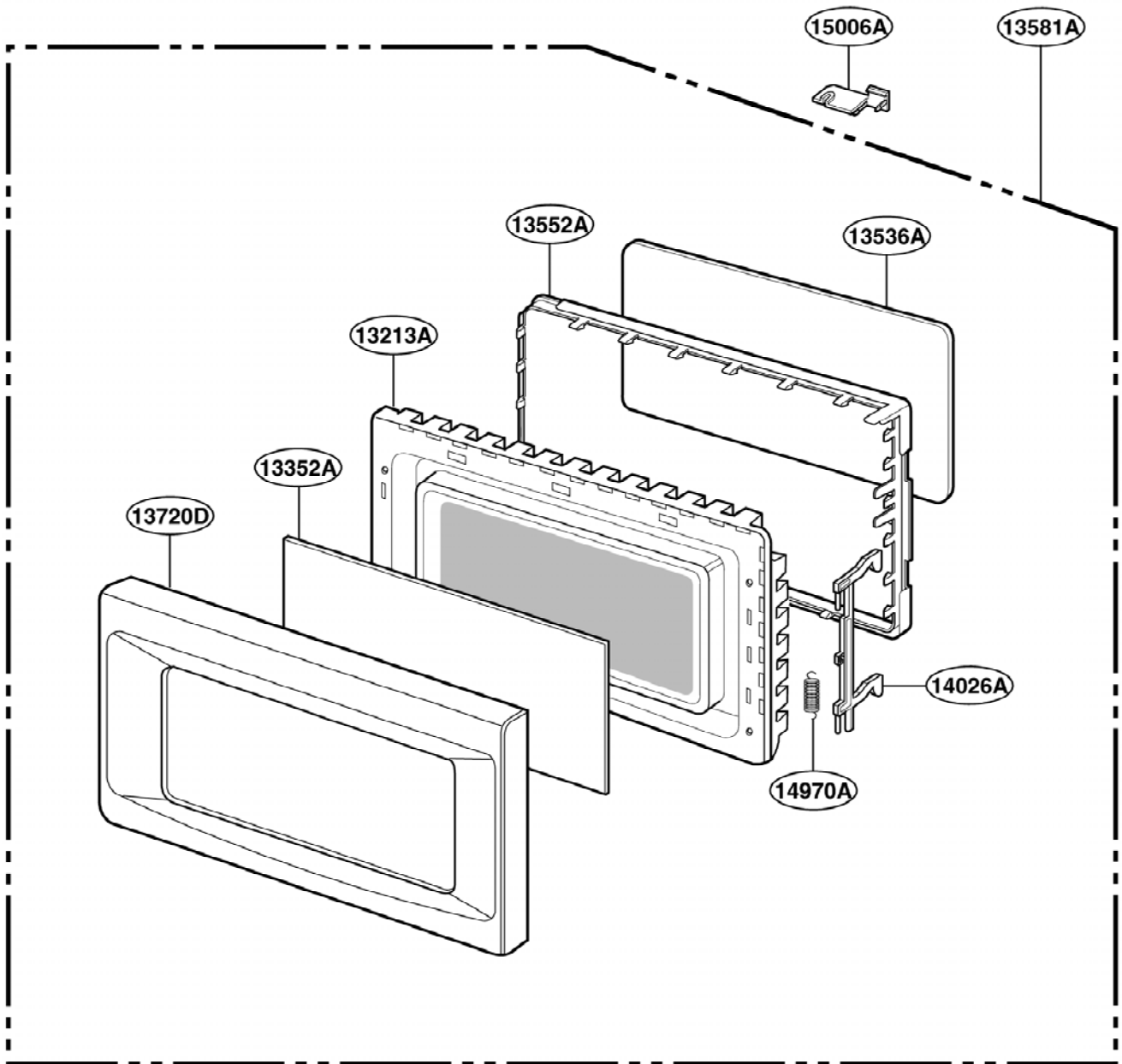

CONTROL PANEL PARTS

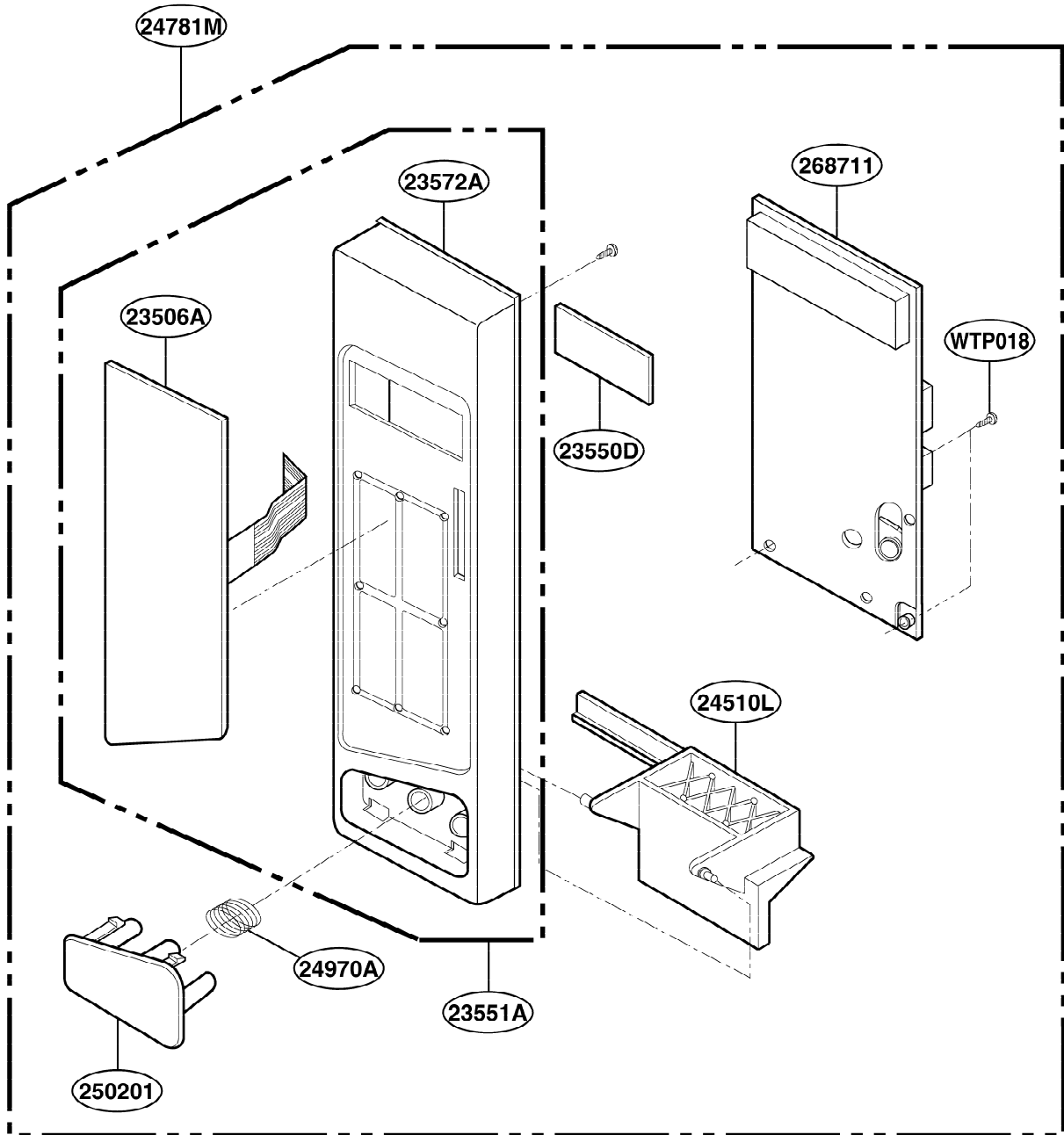

OVEN CAVITY PARTS

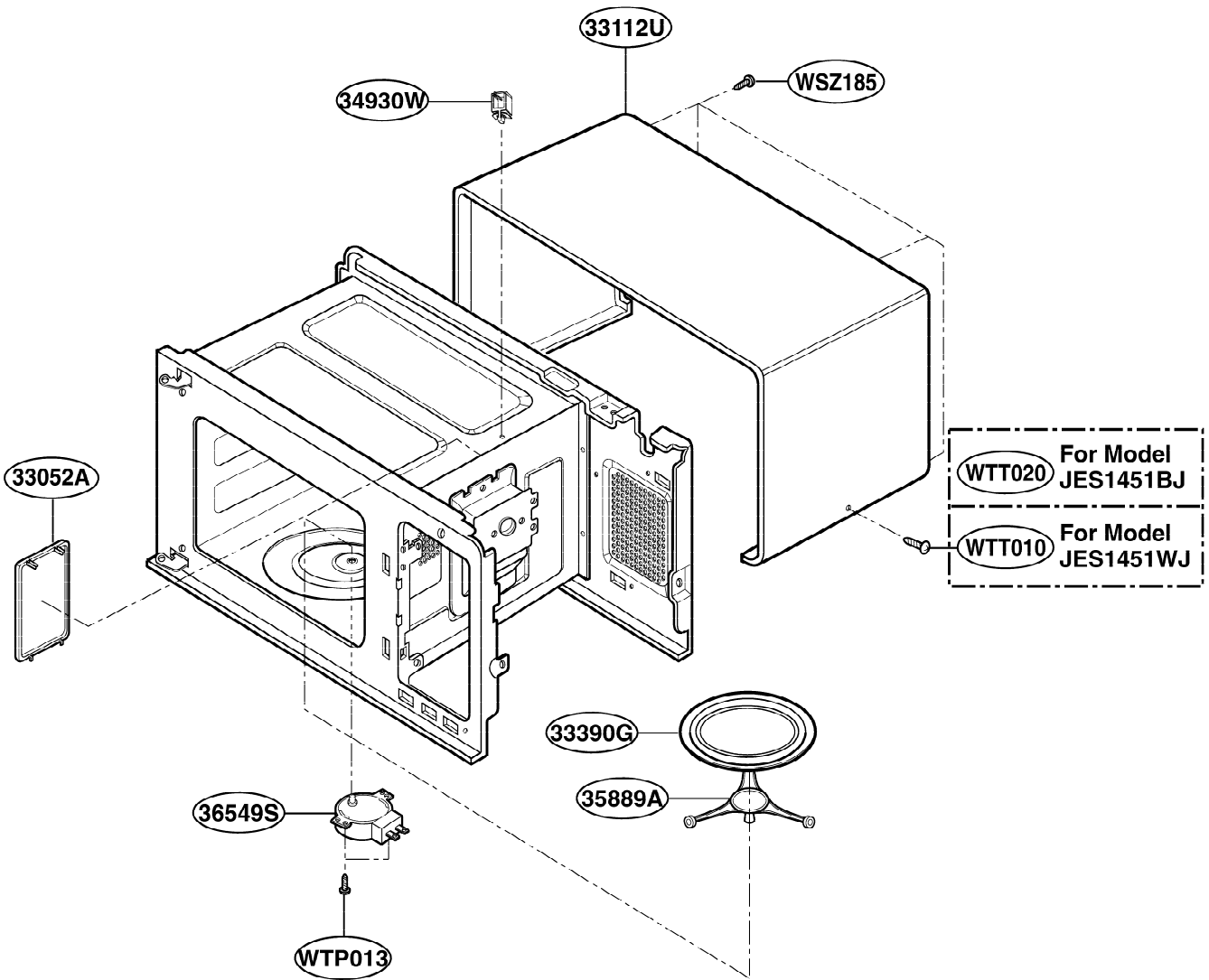

LATCH BOARD PARTS

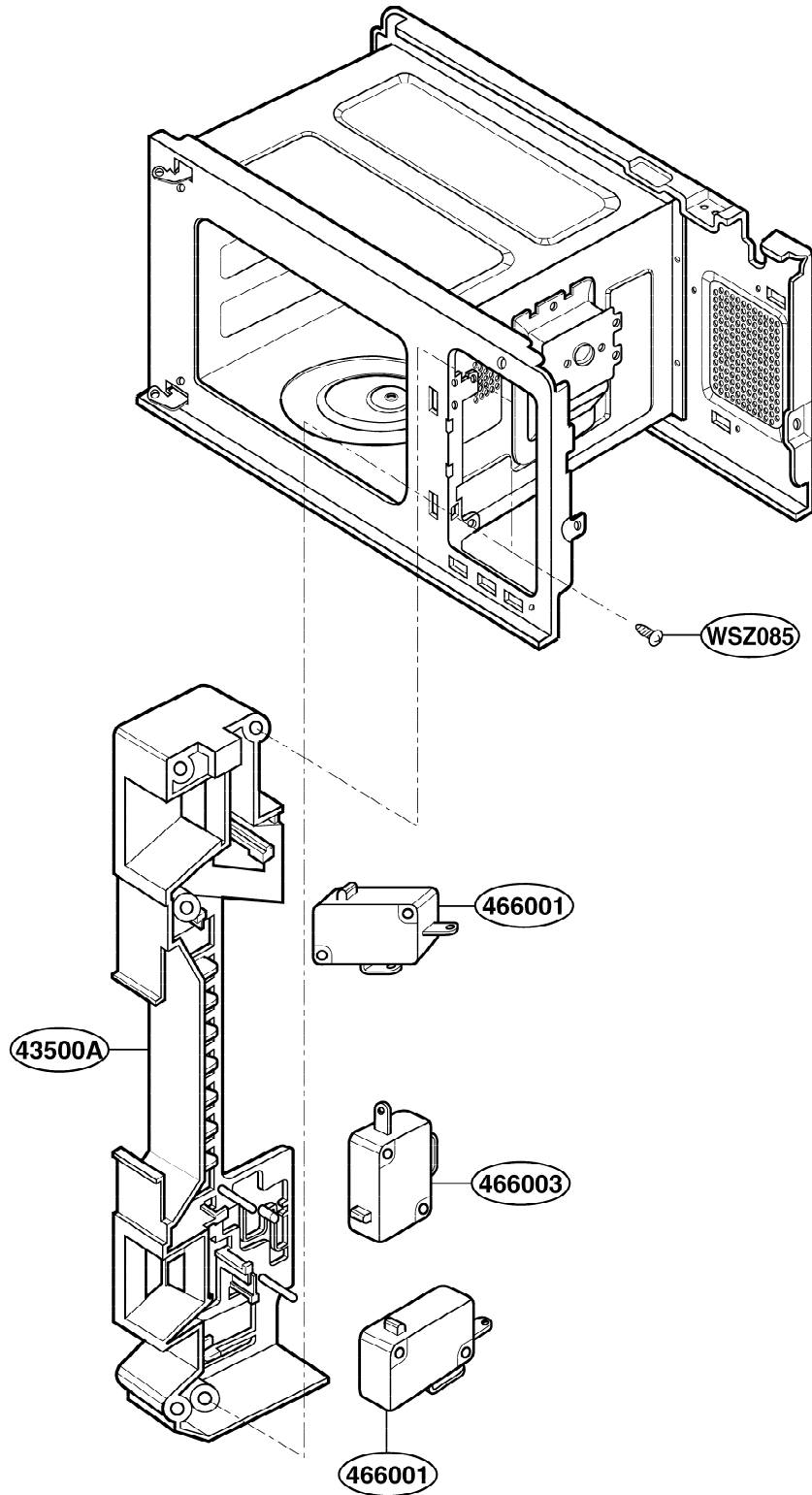

INTERIOR PARTS (I)

Model: JES1451WJ 01
JES1451BJ 01

Check the rating label of **Model** and order SVC parts according to the **Model No.**

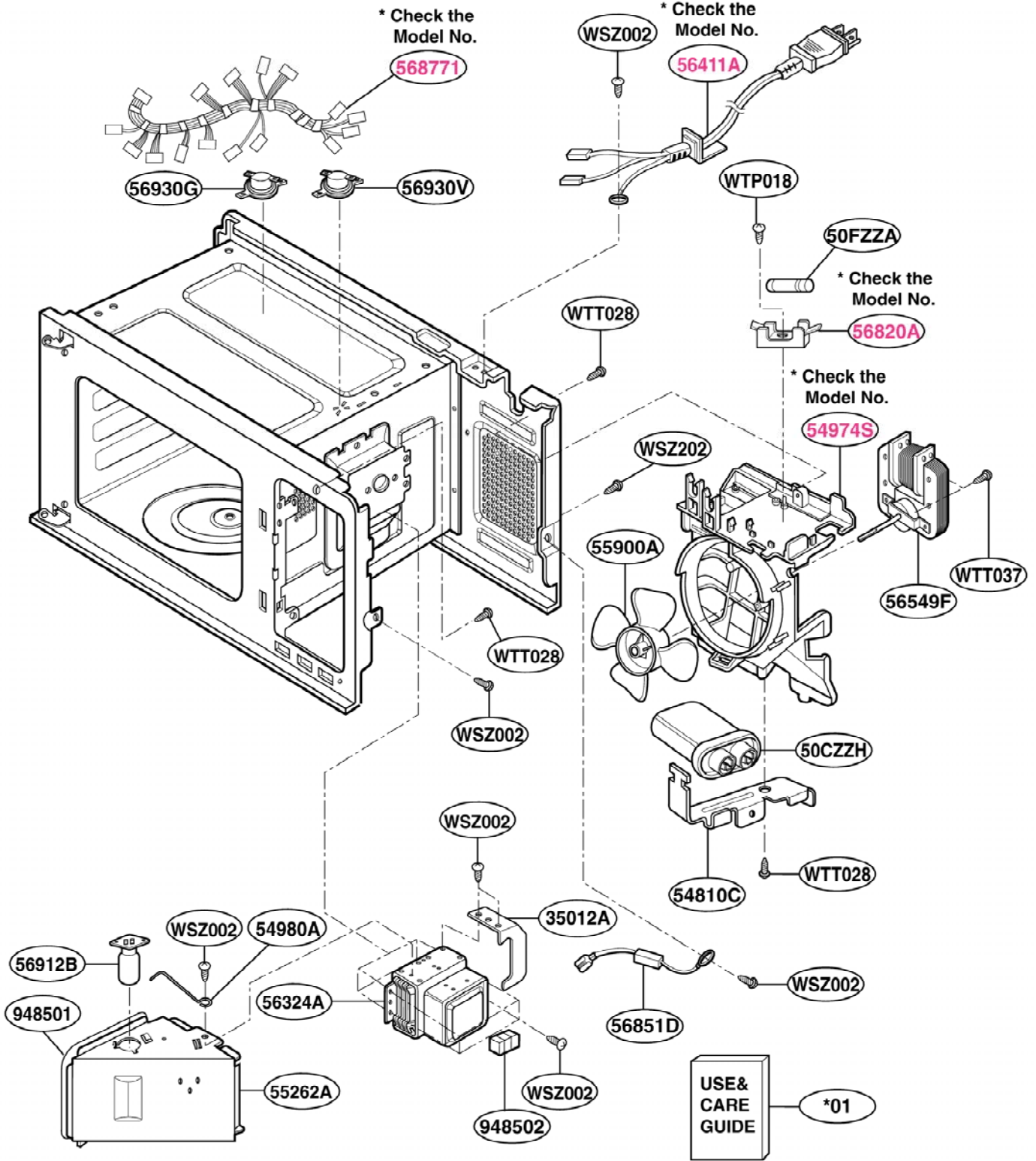

INTERIOR PARTS (II)

Model: JES1451WJ 02
JES1451BJ 02

Check the rating label of **Model** and order SVC parts according to the **Model No.**

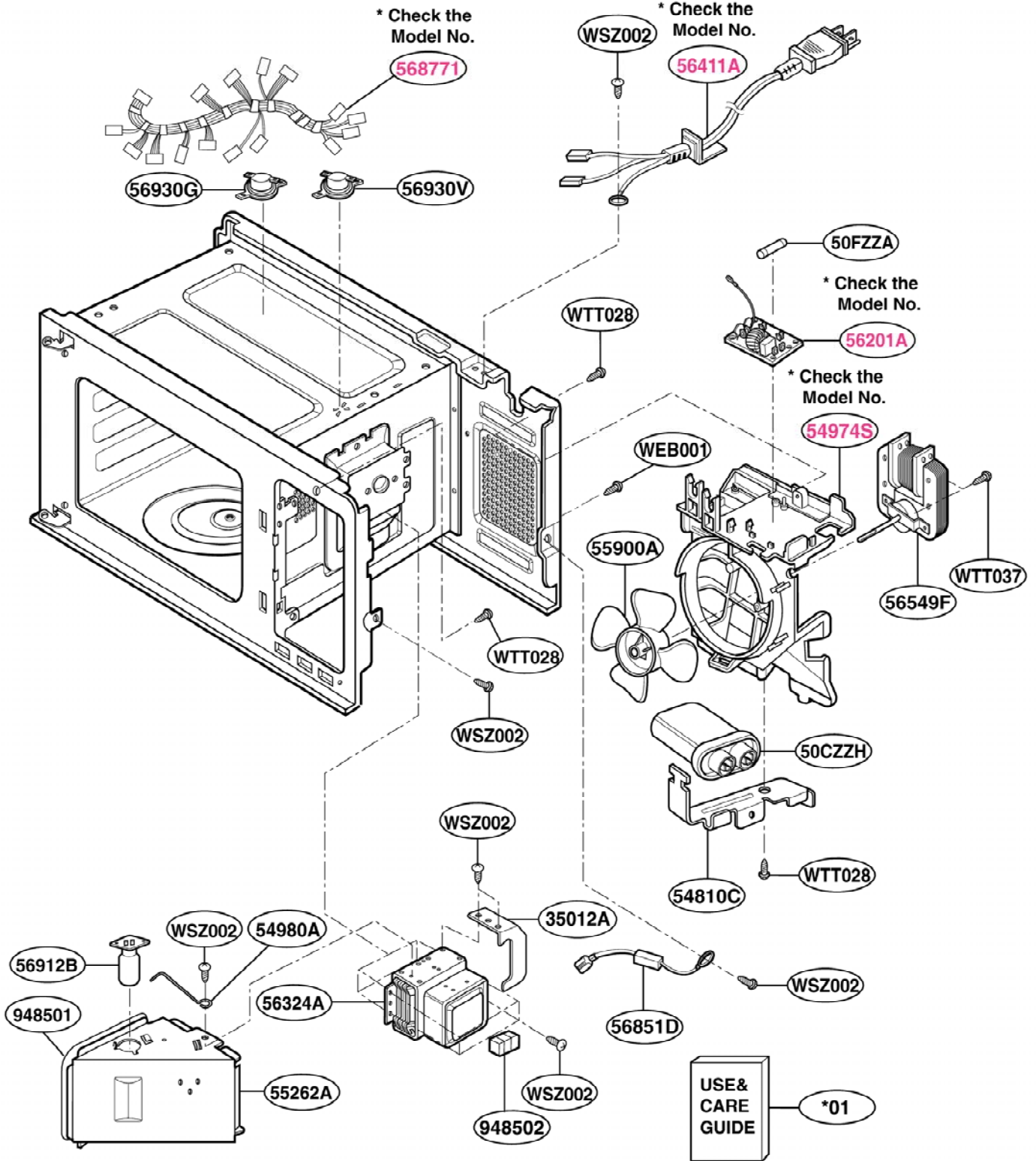

BASE PLATE PARTS

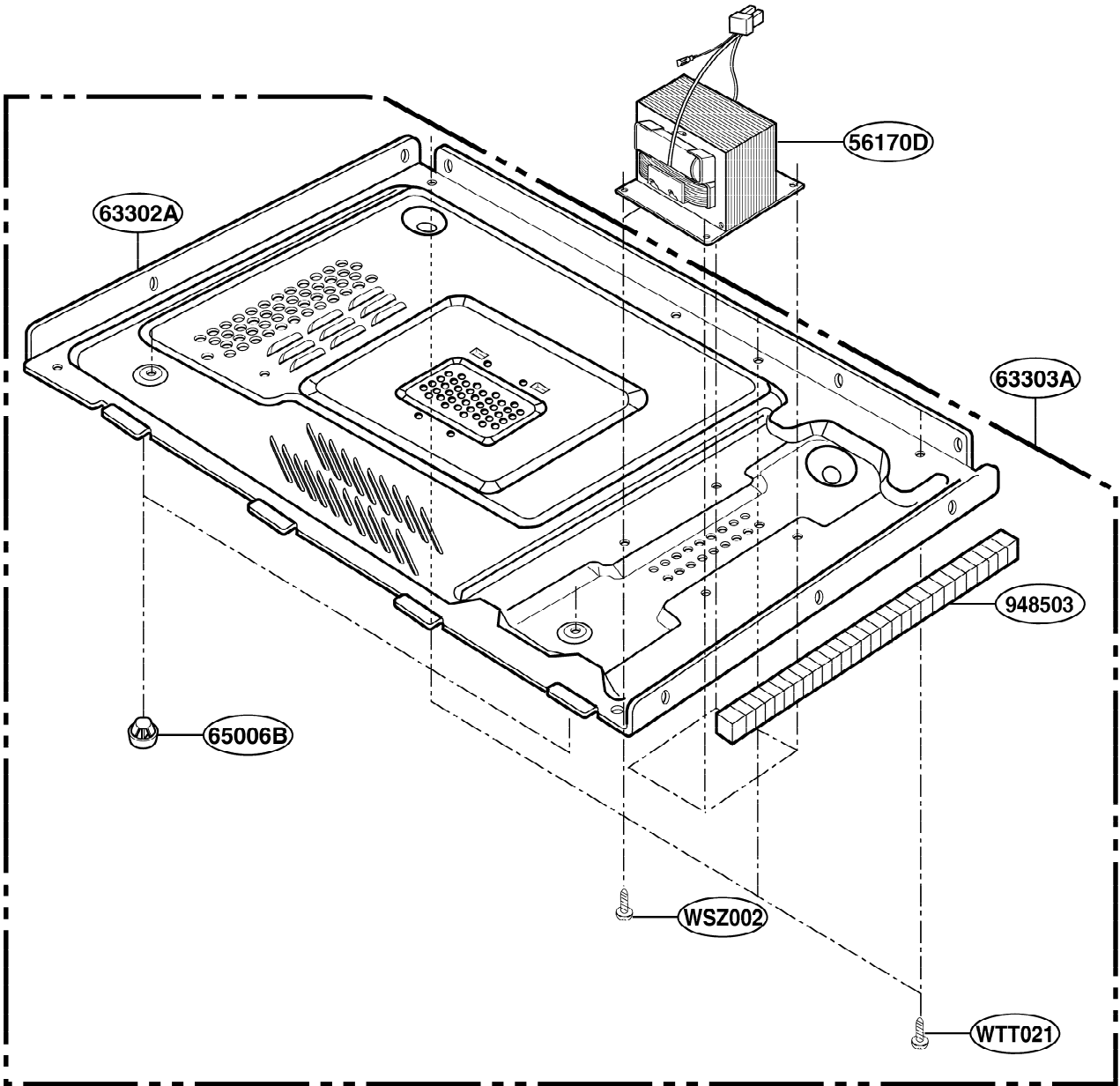

SENSOR PARTS

