

ASSEMBLY & OPERATING INSTRUCTIONS

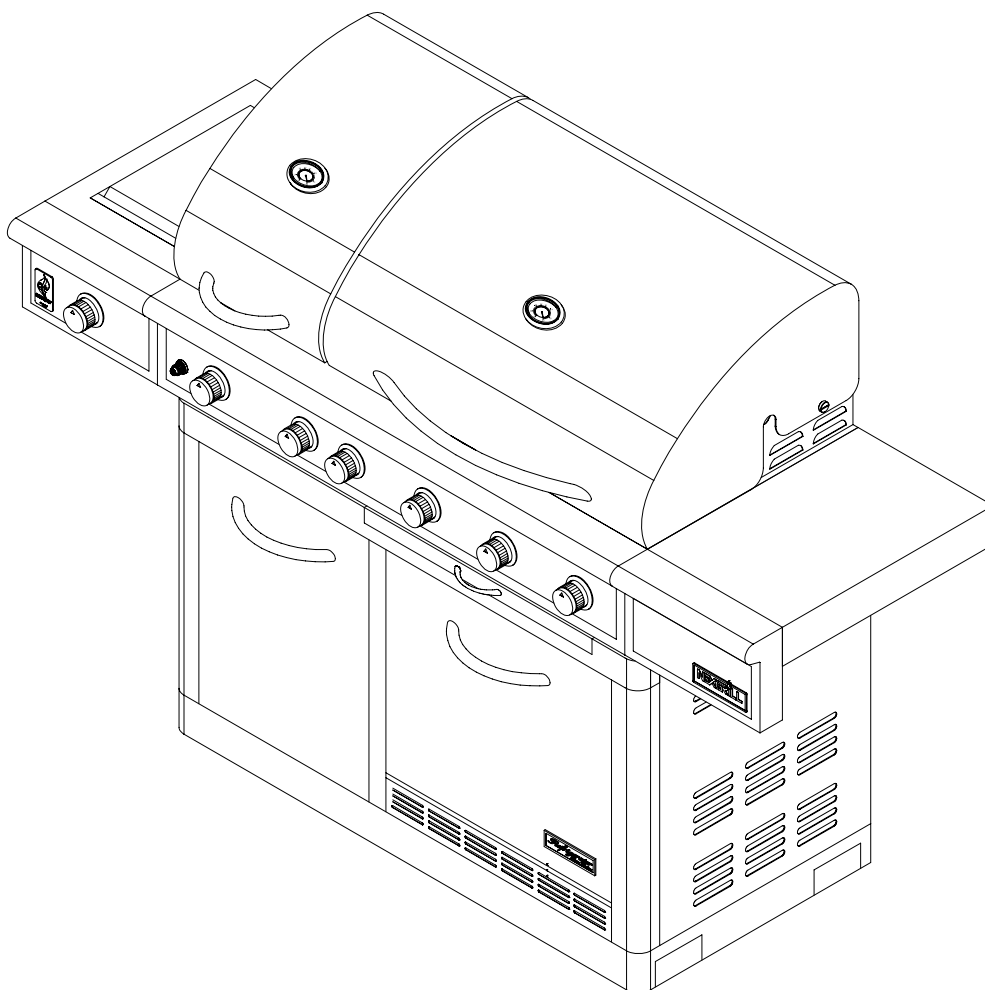

Model: 720-0617



FOR PROPANE GAS USE ONLY

FOR OUTDOOR USE ONLY

This instructions manual contains important information necessary for the proper assembly and safe use of the appliance.

Read and follow all warnings and instructions before assembling and using the appliance



Follow all warnings and instructions when using the appliance



Keep this manual for future reference

Table of Contents

Safety Instruction	2-7	Refrigerator Installation Instruction.	31
Assembly Instruction	8-13	Refrigerator Technical Data	32
Gas Hook –Up	14-15	Care and Maintenance	33-36
Installer Final Check List	15	Troubleshooting	36-39
Leak Testing	16-17	Exploded View	40
Operating Instruction	18	Part List	41-42
Lighting Instruction	19-20	Ordering Parts	43
Lighting Illustration	21	Grill Hints	43
Match Lighting Instruction	22	Grill Cooking Chart	44-45
Gas Conversion From LP to NG	23-28	Grill Recipe Suggestion	46-48
Motor Instruction	29	Limited Warranty	49
Refrigerator Safe Guide	30		

Safety Instruction

 DANGER	 WARNING
<p>If you smell gas:</p> <ol style="list-style-type: none"> 1. Shut off gas to the appliance. 2. Extinguish any open flame. 3. Open lid 4. If odor continues, keep away from the appliance and immediately call you gas supplier or your fire department. 	<ol style="list-style-type: none"> 1. Do not store or use gasoline or other flammable liquids or vapors in the vicinity of this or any other appliance. 2. An LP cylinder not connected for use shall not be stored in the vicinity of this or any other appliance.

-  Failure to comply with these instructions could result in a fire or explosion that could cause serious bodily injury, death, or property damage.
-  Combustion by products produced when using this product contain chemicals known to the States of California to cause cancer, birth defects, or other reproductive harm
-  Your grill will be very hot. Never lean over the cooking area while using your grill. Do not touch cooking surfaces, grill housing, lid or any other grill parts while the grill is in operation, or until the gas grill has cooled down after use.

IMPORTANT: READ THE FOLLOWING PRIOR TO CONNECTING POWER AND USE

To reduce the risk of fire, electrical shock or injury when using this unit, follow basic precaution, including the following.

Remove all packages before using this unit.



WARNING

ELECTRICAL GROUNDING INSTRUCTIONS This appliance (rotisserie motor) is equipped with a plug and should be plugged directly into a properly grounded receptacle. When installed, must be electrically grounded in accordance with local codes or in the absence of local codes, with the National Electrical Code, ANSI/NFPA 70 or the Canadian Electrical Code, CSA C22.1 DO NOT cut or remove the grounding prong from this plug.

1. To protect against electric shock, do not immerse cord or plugs in water or other liquid.
2. Unplug from the outlet when not in use and before cleaning. Allow to cool before putting on or taking off parts.
3. Do not operate any outdoor cooking gas appliance with a damaged cord, plug, or after the appliance malfunctions or has been damaged in any manner. Contact the manufacturer for repair.
4. Do not let the cord hang over the edge of a table or touch hot surface.
5. Do not use an outdoor cooking gas appliance for purposes other than intended.
6. When connecting, first connect plug to the outdoor cooking gas appliance then plug appliance into the outlet.
7. Use only a Ground Fault Interrupt (GFI) protected circuit with this outdoor cooking gas appliance.
8. Never remove the grounding plug or use with an adapter of 2 prongs.
9. Use only extension cords with a 3 prong grounding plug, rated for the power of the equipments, and approved for outdoor use with a W-A marking.



DANGER

1. Plug into a grounded 3-prong outlet, do not remove grounding prong, do not use an adapter, and do not use an extension cord.
2. It is recommended that a separate circuit, serving only your refrigerator be provided. Use receptacles that cannot be turned off by a switch or pull chain.
3. Never clean refrigerator parts with flammable fluids. These fumes can create a fire hazard or explosion. And do not store or use gasoline or other flammable vapors and liquids in the vicinity of this or any other appliance. The fumes can create a fire hazard or explosion.
4. Before proceeding with cleaning and maintenance operations, make sure the power line of the unit is disconnected.
5. Do not connect or disconnect the electric plug when your hands are wet.
6. Unplug the refrigerator or disconnect power before cleaning or servicing. Failure to do so can result in electrical shock or death.
7. Do not attempt to repair or replace any part of your refrigerator unless it is specifically recommended in this manual. All other servicing should be referred to a qualified technician.



WARNING

Do not try lighting this appliance without reading the "LIGHTING INSTRUCTIONS" section of this manual.

TESTED IN ACCORDANCE WITH ANSI Z21.58 CSA 1.6-2007 STANDARD FOR OUTDOOR COOKING GAS APPLIANCE. THIS GRILL IS FOR OUTDOOR USE ONLY.

Grill Installation Codes

Check your local building codes for the proper method of installation. In the absence of local codes, this unit should be installed in accordance with the National Fuel Gas Code, ANSI Z223.1/NFPA 54, Storage and Handling of Liquefied Petroleum Gases, ANSI/NFPA B149.2 or Natural Gas and Propane Installation Code, CSA B149.1 and the National Electrical Code, ANSI/NFPA 70.

Correct LP Gas Tank Use

LP gas grill models are designed for use with a standard 20 lb. Liquid Propane Gas tank, not included with grill.

Never connect your gas grill to an LP gas tank that exceeds this capacity.

If an external electrical source is utilized: The outdoor cooking gas appliance, when installed, must be electrically grounded in accordance with local codes or, in the absence of local codes, with the National Electrical Code, ANSI/NFPA 70, or the Canadian Electrical Code, CSA C22.1.

WARNING

Keep any electrical supply cord and the fuel supply hose away from any heated surfaces.

NOTE: The normal flow of gas through the regulator and hose assembly can create a humming noise. A low volume of noise is perfectly normal and will not interfere with operation of the grill. If humming noise is loud and excessive you may need to purge air from the gas line or reset the regulator excess gas flow device. This purging procedure should be done every time a new LP gas tank is connected to your grill.

CAUTION: Beware of Flashback

CAUTION: Spiders and small insects occasionally spin webs or make nest in the grill burner tubes during transit and warehousing. These webs can lead to gas flow obstruction, which could result in a fire in and around burner tubes. This type of fire is known as "FLASH-BACK" and can cause serious damage to your grill and create an unsafe operating condition for the user.

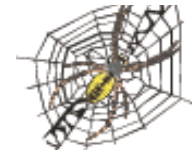

Although an obstructed burner tube is not the only cause of "FLASH-BACK", it is the most common cause.

To reduce the chance of "FLASH-BACK", you must clean the burner tubes before assembling your grill, and at least once a month in late summer or early fall when spiders are most active. Also perform this burner tube cleaning procedure if your grill has not been used for an extended period of time. A clogged tube can lead to a fire beneath the grill.

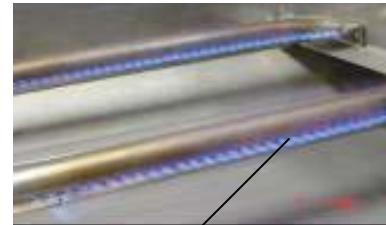

Visually check the burner flames prior to each use. The flames should look like this picture. If they do not, refer to the burner maintenance part of this manual.



LP-Gas Supply System



- If the information is not followed exactly, a fire resulting in death or serious injury could occur.
- A 20lb tank of approximately 12 inches in diameter by 18-1/4 inches high is the maximum size LP gas tank to use.
- This safety feature prevents the tank from being overfilled, which can cause malfunction of the LP gas tank, regulator and/or grill.
- The LP gas supply cylinder to be used must be constructed and marked in accordance with the specifications for LP –Gas cylinder of the U.S. Department of Transportation (DOT) or the National Standard of Canada ,CAN/CSA –B339, Cylinders, Spheres and Tubes for Transportation of Dangerous Goods and Commission .
- The LP gas tank must have a shutoff valve terminating in an LP valve outlet that is compatible with a Type 1. LP gas supply cylinder must have a shut off valve terminating in a valve outlet specified for connection type QCC1 in the standard for compressed gas cylinder valve outlet and inlet connection ANSI/CGA-V-1 as applicable. LP gas supply cylinder must be fitted with an Overfill Protection Device (O.P.D) The LP gas tank must also have a safety relief device that has a direct connection with the vapor space of the tank.
- The tank supply system must be arranged for vapor withdrawal.
- The LP gas tank used must have a collar to protect the tank valve
- Place dust cap on cylinder valve outlet whenever the cylinder is not in use. Only install the type of dust cap on the cylinder valve outlet that is provided with the cylinder valve. Other types of cap or plugs may result in leakage of propane
- **Never** connect an unregulated LP gas tank to your gas grill.
- This outdoor cooking gas appliance is equipped with a high capacity hose/regulator assembly for connection to a standard 20lb. Liquid propane cylinder.
- Have your LP gas tank filled by a reputable propane gas dealer and visually inspected and re-qualified at each filling.
- Do not store a spare LP gas cylinder under or near this appliance.
- Never fill the cylinder beyond 80 percent full .
- Always keep LP gas tanks in an upright position.
- Do not store or use gasoline or other flammable vapors and liquids in the vicinity of this or any other appliance.
- Storage of an outdoor cooking gas appliance indoors is permissible only if the cylinder is disconnected and removed from the outdoor cooking gas appliance..
- When your gas grill is not in use the gas must be turned off at LP gas tank.
- The gas must be turned off at the supply cylinder when the outdoor cooking gas appliance is not in use.
- LP gas tank must be stored outdoors in a well-ventilated area and out of reach of children. Disconnected LP gas tanks must not be stored in a building, garage or any other enclosed area.

PROPER PLACEMENT AND CLEARANCE OF GRILL

- Never use your gas grill in a garage, porch, shed, breezeway or any other enclosed area. Your gas grill is to be used outdoors only.
- Do Not install this unit into combustible enclosures.
- Minimum clearance from sides and back of unit to combustible construction, 24 inches (61cm) from sides and 24 inches (61cm) from back.
- **DO NOT** use this appliance under overhead combustible surfaces. This outdoors cooking gas appliance is not intend to be installed in or on recreational vehicles and/or boats.
- Do Not obstruct the flow of ventilation air around the gas grill housing. Only use the regulator and the hose assembly supplied with your gas grill. Replacement regulators and hose assemblies must be those specified in this manual.
- The regulator and hose assembly must be inspected before each use of the grill. If there is excessive abrasion or wear or if the hose is cut, it must be replaced prior to the grill being put into operation. The replacement hose assembly shall be that specified by the manufacturer.
- Pressure regulator and hose assembly supplied with the outdoor cooking gas appliance must be used. Never substitute other types of regulator. Contact customer service for manufacturer specified replacement parts.
- This outdoor cooking gas appliance is equipped with a pressure regulator comply with the standard for Pressure Regulating Valves for LP Gas ANSI/ UL 144.
- Do not use briquettes of any kind in the grill.
- The grill is designed for optimum performance without the use of briquettes. Do not place briquettes on the radiant as this will block off the area for the grill burners to vent. Adding briquettes can damage ignition components and knobs, and void the warranty.
- Keep the back and side cart free and clear from debris. Keep any electrical supply cord, or the rotisserie motor cord away from the heated areas of the grill.
- Never use the grill in extremely windy conditions. If located in a consistently windy area (oceanfront, mountaintop, etc.) a windbreak will be required. Always adhere to the specified clearance.
- Never use a dented or rusty propane tank.
- Keep any electrical supply cord and the fuel supply hose away from any heated surface
- While lighting, keep your face and hands as far away from the grill as possible.
- Burner adjustment should only be performed after the burner have cooled.

 WARNING
<p>Your grill will get very hot. Never lean over the cooking area while using your grill. Do not touch cooking surfaces, grill housing, lid or any other grill hot surface while the grill is in operation, or until the gas grill has cooled down after use.</p> <p>Failure to comply with these instructions may result in serious bodily injury.</p>
<p>ROTISSERIE DRIVE MOTOR USE ONLY FOR OUTDOORS, DO NOT EXPOSE TO RAIN.</p> <p>CAUTION: TO ENSURE CONTINUED PROTECTION AGAINST RISK OF ELECTRIC SHOCK, CONNECT TO PROPERLY GROUNDED OUTLETS ONLY. TO REDUCE THE RISK OF ELECTRIC SHOCK, KEEP EXTENSION CORD CONNECTION DRY AND OFF THE GROUND.</p>
<p style="text-align: center;">INSECT WARNING:</p> <p>Spiders and insects can nest in the burners of this and any other grill, and cause the gas to flow improperly. This is a very dangerous condition, which can cause a fire to occur behind and beneath the valve panel, thereby damaging the grill and making it unsafe to operate. Inspect the grill at least twice a year.</p>
 WARNING
<p>Keep a spray bottle of soapy water near the gas supply valve and check the connections before each use.</p>
<p>DO NOT USE ALUMINUM FOIL TO LINE THE GRILL RACKS OR GRILL BOTTOM.</p> <p>This can severely upset combustion airflow or trap excessive heat in the control area.</p>
<p>DO NOT LEAVE THE GRILL UNATTENDED WHILE COOKING.</p>

SAFETY PRACTICES TO AVOID PERSONAL

INJURY

When properly cared for, your grill will provide safe, reliable service for many years. However, extreme care must be used as the grill produces intense heat that can increase accident potential. When using this appliance basic safety practices must be followed, including the following:

Do not repair or replace any part of the grill unless specifically recommended in this manual. All other service should be referred to a qualified technician.

This grill is not intended to be installed in or on recreational vehicles or boats

Children should not be left alone or unattended in an area where the grill is being used. Do not allow them to sit, stand or play in or around the grill at any time.

Do not store items of interest to children around or below the grill.

Do not permit clothing, pot holders or other flammable materials to come in contact with or too close to any grate, burner or hot surface until it has cooled. The fabric could ignite and cause personal injury.

For personal safety, wear proper apparel. Loose fitting garments or sleeves should never be worn while using this appliance. Some synthetic fabrics are highly flammable and should not be worn while cooking.

Only certain types of glass, heat-proof glass ceramic, earthenware, or other glazed utensils are suitable for grill use. These materials may break with sudden temperature changes. Use only on low or medium heat settings in accordance with the manufacturer's guidelines.

Do not heat unopened food containers. A build-up of pressure may cause the containers to burst.

Use a covered hand when opening the grill lid.

Never lean over an open grill.

When lighting a burner, pay close attention to what you are doing. Make certain you are aware of which burner you are lighting, so your body and clothing remain clear of open flames.

When using the grill, do not touch the grill rack, burner grate or immediate surroundings as these areas become extremely hot and could cause burns. Use only dry potholders. Moist or damp potholders on hot surfaces may cause steam burns. Do not use a towel or bulky cloth in place of potholders. Do not allow potholders to touch hot portions of the grill rack.

Grease is flammable. Let hot grease cool before attempting to handle it. Do not allow grease deposits to collect in the grease tray at the bottom of the grill's firebox. Clean the grease tray often.

Do not use aluminum foil to line the grill racks or grill bottom. This can severely upset combustion air flow or trap excessive heat in the control area.

For proper lighting and performance of the burners keep the burner ports clean. It is necessary to clean them periodically for optimum performance. The burners will only operate in one position and must be mounted correctly for safe operation.

Clean the grill with caution. To avoid steam burns, do not use a wet sponge or cloth to clean the grill while it is hot. Some cleaners produce toxic fumes or can ignite if applied to a hot surface.

Turn off grill controls and make certain the grill is cool before using any type of aerosol cleaner on or around the grill. The chemical that produces the spraying action could, in the presence of heat, ignite or cause metal parts to corrode.

Do not use the grill to cook excessively fatty meats or other products which promote flare – ups.

Do not operate the grill under unprotected combustible constructions. Use only in well ventilated areas. Do not use in buildings, garages, sheds, breezeways or other such enclosed areas.

Keep the area surrounding the grill free from combustible materials including fluids, trash, and vapors such as gasoline or charcoal lighter fluid. Do not obstruct the flow of combustion and air ventilation.



WARNING

This outdoor cooking gas appliance is not intended to be installed in or on boats. For other than RV grills, a statement that this appliance is not intended to be installed in or on recreational vehicles.

PLEASE READ THE INSTRUCTIONS CAREFULLY AND FOLLOW STEP BY STEP.

TOOLS REQUIRED:

(1)PHILIPS HEAD SCREWDRIVER-NOT PROVIDED

STEP 1:

Assemble the panel of the side burner with four screws, as shown below.

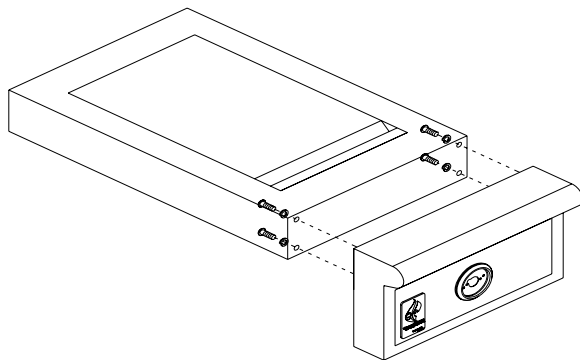

Screw size: 1/4 x 10mm

Washer size: 1/4



STEP 2:

Assemble the side shelf with four screws, as shown below.

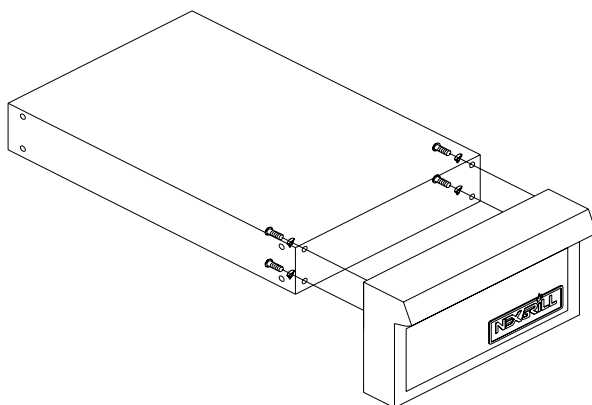

STEP 3:

- A. The screws used to attach the side burner module are already screwed into the left panel (see the figure below). Remove the screws from the left panel, align with the holes on the side burner module, and then re-screw into the holes on the left panel of the grill.
- B. The screws used to attach the side shelf are already screwed into the right panel (see the figure below). Remove the screws from the right panel, align with the holes on the side shelf, and then re-screw into the holes on the right panel of the grill.

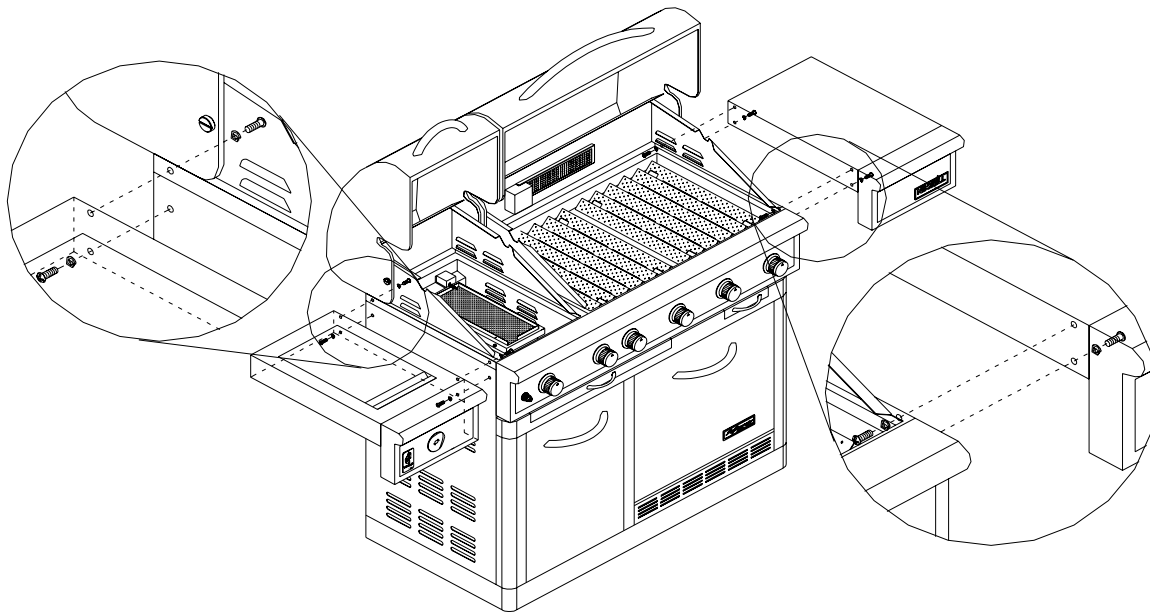

STEP 4:

Insert valve stem assembly into control panel, align and tighten knob bezel and valve stem with two screws and two washers. Then connect the ignition wire to the valve.

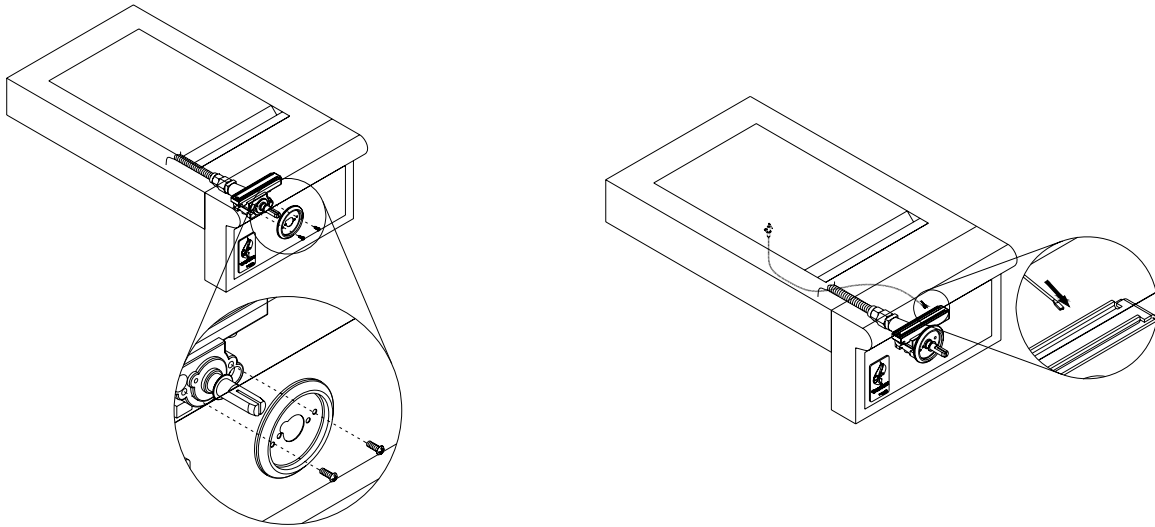

STEP 5:

Place knob on valve stem and secure with wrench.

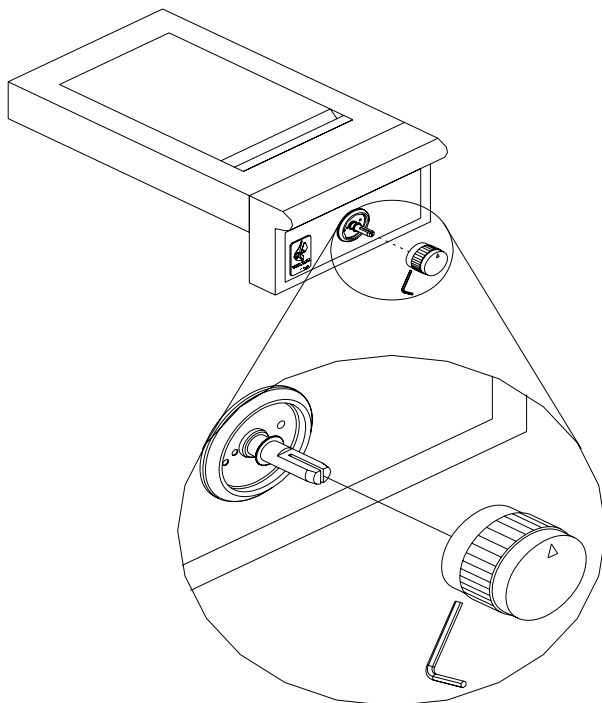

STEP 6:

Insert side burner hose quick connector to the side burner gas valve.

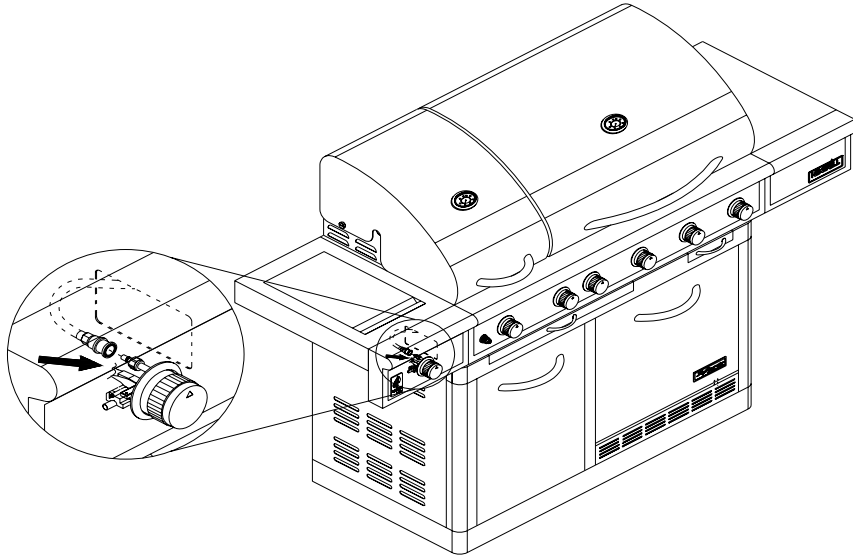

STEP 7:

Battery is inserted for the rotisserie burner . To install the battery, turn counterclockwise to remove the ignition button cap. Restore the ignition button cap after the battery is installed.

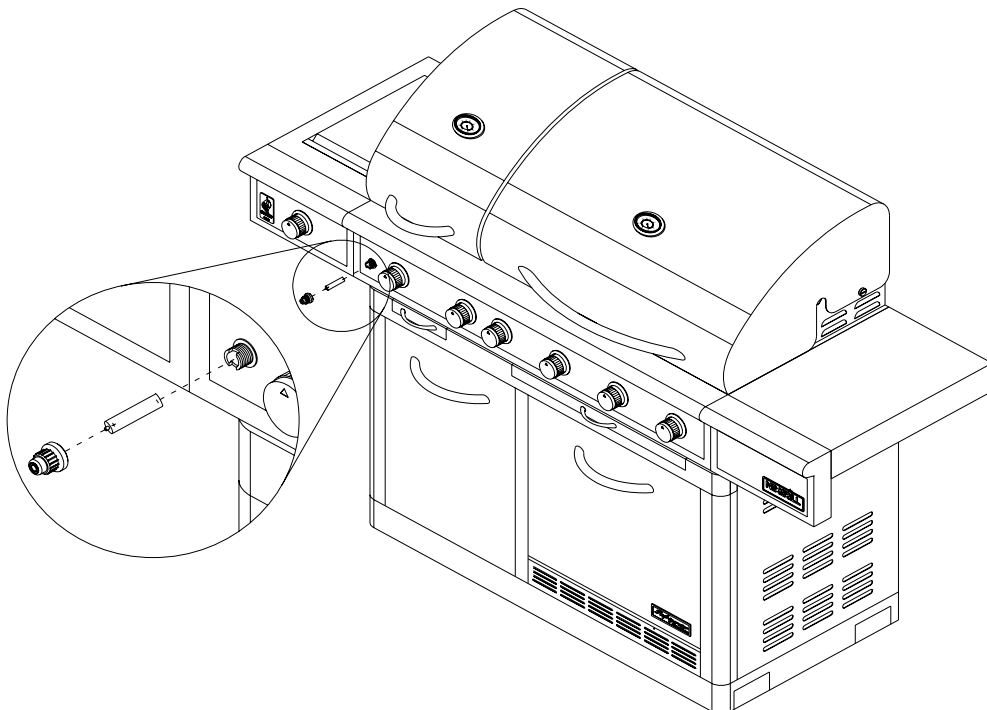

STEP 8:

Attach propane gas tank to regulator by turning the regulator coupling clockwise as shown in figure below. LP gas cylinder must be fitted with a listed overfill prevention device (OPD). Secure liquid propane gas cylinder in the slide-out tray using the gas cylinder retention screw.

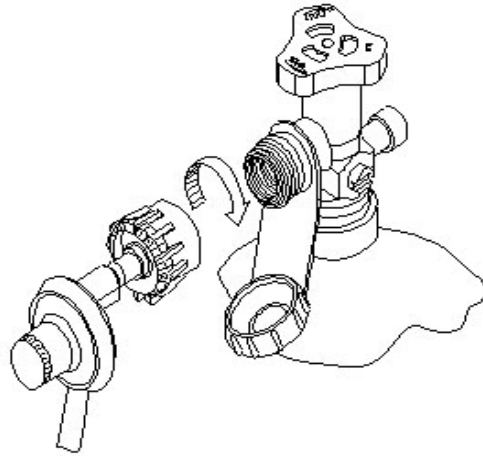

CYLINDER TANK FIXED

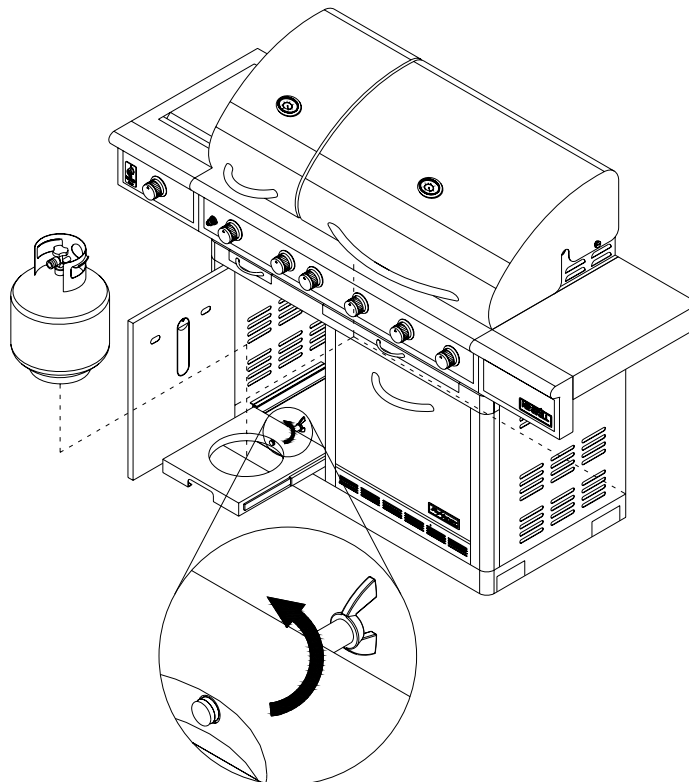

STEP 9:

The screws for rotisserie motor bracket are screwed into the right side of the grill housing. Remove the screws and install the rotisserie motor bracket as shown in the figure below. Assemble the rotisserie skewer as shown in the figure below.

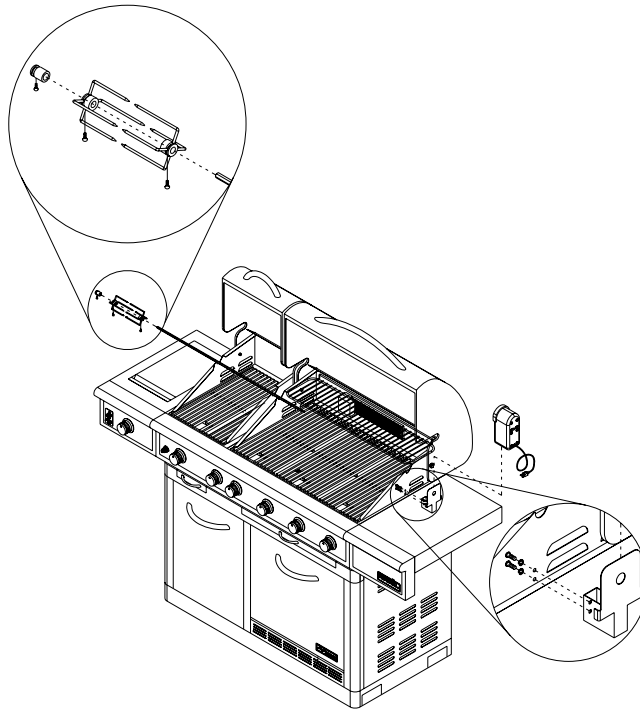

Gas tank opener use instruction:

- a. When you keep the opener part level as below, the tank tray won't be pulled out.
- b. When you keep the opener part vertical as below, the tank tray can be pulled out.



NEVER CONNECT AN UNREGULATED GAS SUPPLY LINE TO THE APPLIANCE. USE THE REGULATOR/HOSE ASSEMBLY SUPPLIED.

This is a liquid propane configured grill. Do not attempt to use a natural gas supply unless the grill has been reconfigured for natural gas use.

Total gas consumption (per hour) of this stainless steel gas grill with all burners on "HI":

Main burner	4 @ 11,000 BTU/HR
Side burner	1 @ 12,000 BTU/HR
Rear burner	1 @ 10,000 BTU/HR
<u>Sear burner</u>	<u>1 @ 18,000 BTU/HR</u>
Total	84,000 Btu/hr.

L.P. TANK REQUIREMENT

A dented or rusty L.P. tank may be hazardous and should be checked by your L.P. supplier. Never use a cylinder with a damaged valve. The L.P. gas cylinder must be constructed and marked in accordance with the specifications for L.P. gas cylinders of the U.S. Department of Transportation (DOT) or the National Standard of Canada, CAN/CSA-B339, Cylinders, Spheres and Tubes for Transportation of Dangerous Goods; and Commission, as applicable. Overfilling prevention device (OPD) shall be provided on cylinder & QCC1 connection on the cylinder valve, ANSI/CGA-V-1. The cylinder supply system must be arranged for vapor withdrawal. The cylinder must include a collar to protect the cylinder valve. The cylinder must be provided with a shut off valve terminating in an L.P. gas supply cylinder valve outlet specified, as applicable, for connection type

QCC1 in the standard for compressed gas cylinder valve outlet and inlet connection ANSI/CGA-V-1.

Manifold pressure: 11"(27.94cm) water column (W.C.).

L.P. GAS HOOK-UP

Ensure that the black plastic grommets on the LP cylinder valve are in place and that the hose does not come into contact with the grease tray or the grill head.

CONNECTION

Your stainless steel grill is equipped with gas supply orifices for use only with liquid propane gas. It is also equipped with a high capacity hose/regulator assembly for connection to a standard 20lb. L.P. cylinder (18-1/4" (46.35cm) high, 12-1/4"(31cm) diameter). To connect the L.P. gas supply cylinder, please follow the steps below:

1. Make sure tank valve is fully in off position (turn clockwise to stop)
2. Check tank valve to assure it has proper external male threads (type 1 connection per ANSIZ21.81)



3. Make sure all burner valves are in the off position.
4. Inspect valve connections, port, and regulator assembly. Look for any damage or debris. Remove any debris. Inspect hose for damage. Never attempt to use damaged or obstructed equipment. See your local L.P. gas dealer for repair.

- When connecting regulator assembly to the valve, hand tighten the quick coupling nut clockwise to a complete stop. Do not use a wrench to tighten. Use of a wrench may damage the quick coupling nut and result in a hazardous condition.
- Open the tank valve fully (counterclockwise). Apply the soap solution with a clean brush to all gas connections. See below. If growing bubbles appear in the solution the connections are not properly sealed. Check each fitting and tighten or repair as necessary.
- If you have a gas connection leak you cannot repair, turn gas OFF at supply tank, disconnect fuel line from your grill and call 1-866-984-7455 or your gas supplier for repair assistance.
- Also apply soapy solution to the tank seams. See below. If growing bubbles appear, shut tank OFF and do not use or move it! Contact an LP gas supplier or your fire department for assistance.

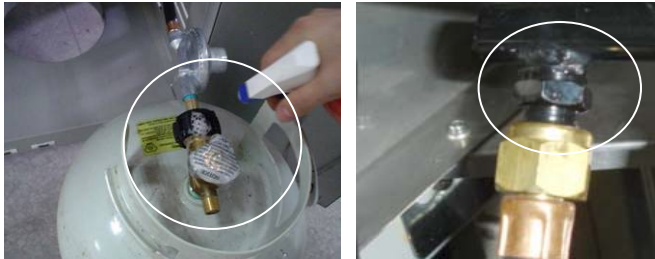
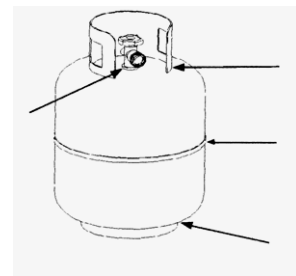

To disconnect L.P. gas cylinder:

- Turn the burner valves off.
- Turn the tank valve off fully (turn clockwise to stop).
- Detach the regulator assembly from the tank valve by turning the quick coupling nut counterclockwise.

Installer Final Check List

- ✓ Specified clearance maintained 24”(61cm) from combustibles.
- ✓ All internal packaging removed.
- ✓ Knobs turn freely.
- ✓ Burners are tight and sitting properly on orifices.
- ✓ Pressure regulator connected and set. Gas connections to grill using hose & regulator assembly provided (pre-set for 11.0” water column).
- ✓ Unit tested and free of leaks.
- ✓ User informed of gas supply shut off valve location

USER, PLEASE RETAIN THIS MANUAL FOR FUTURE REFERENCE.

PROPANE CYLINDER CAUTIONS

- Do Not store a spare LP-gas cylinder under or near this appliance.
- NEVER fill the cylinder beyond 80 percent full.
- If the information in “a” and “b” is not followed exactly, a fire or explosion causing death or serious injury may occur.

GENERAL

Although all gas connections on the grill are leak tested at the factory prior to shipment, a complete gas tightness check must be performed at the installation site due to possible mishandling in shipment, or excessive pressure unknowingly being applied to the unit. Periodically check the whole system for leaks following the procedures listed below. If the smell of gas is detected at anytime you should immediately check the entire system for leaks.

BEFORE TESTING

Make sure that all packing material is removed from the grill including tie-down straps.

DO NOT SMOKE WHILE LEAK TESTING.

NEVER PERFORM LEAK TEST WITH AN OPEN FLAME.

Make a soap solution of one part liquid detergent and one part water. You will need a spray bottle, brush, or rag to apply the solution to the fittings. For the initial leak test, make sure the L.P. cylinder is 80% full.

TO TEST

1. Make sure the control valves are in the "OFF" position, and turn on the gas supply.
2. Check all connections from the LP gas regulator and supply valve up to and including the connection to the manifold pipe assembly (the pipe that goes to the burners). Soap bubbles will appear where a leak is present.
3. If a leak is present, immediately turn off the gas supply and tighten the leaky fittings.
4. Turn the gas back on and recheck.
5. Should the gas continue to leak from any of the fittings, turn off the gas supply and contact customer service at 1-866-984-7455.



Only those parts recommended by the manufacturer should be used on the grill.

Substitution will void the warranty. Do not use the grill until all connections have been checked and do not leak.

GAS FLOW CHECK

Each grill burner is tested and adjusted at the factory prior to shipment; however, variations in the local gas supply may make it necessary to adjust the burners. The flames of the burners should be visually checked.

Flames should be blue and stable with no yellow tips, excessive noise or lifting. If any of these conditions exist, check to see if the air shutter or burner ports are blocked by dirt, debris, spider webs, etc. If you have any questions regarding flame stability, please call customer service

1-866-984-7455 .

ALWAYS CHECK FOR LEAKS AFTER EVERY L.P. TANK CHANGE

Check all gas supply fittings for leaks before each use. It is handy to keep a spray bottle of soapy water near the shut-off valve of the gas supply line. Spray all the fittings. Bubbles indicate leaks.

CAUTIONS

Place dust cap on cylinder valve outlet when the cylinder is not in use. Only install the type of dust cap on the cylinder valve outlet that is provided with the cylinder valve. Other types of caps or plugs may result in leakage of propane.

The gas must be turned off at the supply cylinder when the unit is not in use.

If the appliance is stored indoors the cylinder must be disconnected and removed from the appliance. Cylinders must be stored outdoors in a well-ventilated area out of the reach of children.



Your grill is ready to use!

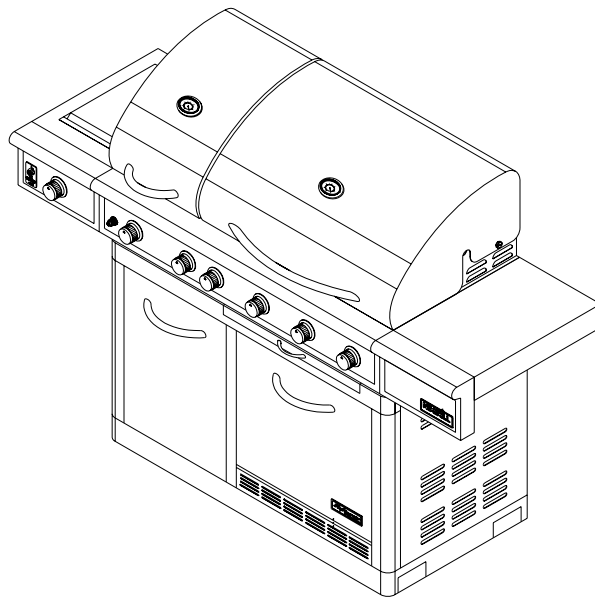

GENERAL USE OF THE GRILL AND ROTISSERIE

Each main burner is rated at 14,000 Btu/hr. The main grill burners encompass the entire cooking area and are side ported to minimize blockage from falling grease and debris. The igniter knobs are located on the lower center portion of the valve panel. Each rotary igniter is labeled on the control panel.

USING THE GRILL

Grilling requires high heat for searing and proper browning. Most foods are cooked at the "HI" heat setting for the entire cooking time. However, when grilling large pieces of meat or poultry, it may be necessary to turn the heat to the lower setting after the initial browning. This cooks the food through without burning the outside. Foods cooked for a long time or foods basted with a sugary marinade may need the lower heat setting near the end of the cooking time.

NOTE: This grill is designed to grill efficiently without the use of lava rocks or briquettes of any kind. Heat is radiated by the flame tamers positioned above each burner.

NOTE: The hot grill sears the food, sealing in the juices. The more thoroughly the grill is preheated, the faster the meat browns and the darker the grill marks.

DO NOT LEAVE THE GRILL UNATTENDED WHILE COOKING.

WARNING: IMPORTANT!

USING THE SIDE BURNER:

Inspect the gas supply hose prior to turning the gas "ON". If there is evidence of cuts, wear or abrasion, it must be replaced prior to use. Do not use the side burner if the odor of gas is present.

USING ROTISSERIE BURNER

Your grill is capable of performing back burner rotisserie cooking. Light the rear burner as described in the lighting illustration. See page 26. Once lit, the rotisserie burner will reach cooking temperatures in about 1 minute.

CAUTION: PLEASE TAKE OFF THE WARMING RACK WHEN USING THE ROTISSERIE BURNER. THE HIGH HEAT COMING FROM THE ROTIS BURNER MAY CAUSE THE WARMING RACK TO WARP.

WARNING: IMPORTANT!

BEFORE LIGHTING...

Inspect the gas supply hose prior to turning the gas "ON". If there is evidence of cuts, wear, or abrasion, it must be replaced prior to use. Do not use the grill if the odor of gas is present. Only the pressure regulator and hose assembly supplied with the unit should be used.

TO LIGHT THE GRILL BURNER:

Make sure all knobs are "OFF" then turn on the gas supply from the LP tank. Always keep your face and body as far from the grill as possible when lighting.

Your grill has an exclusive patented built-in ignition. The igniter is built in to the valve. To ignite each burner simply push and turn the control knobs to the HI setting, you will hear the valve click as it sends a spark to the pilot flame. If the burner does not light wait 5 minutes for any excess gas to dissipate and then retry.

WARNING: Always keep your face and body as far away from the burner as possible when lighting.

TO LIGHT THE SIDE BURNER

To light the side burner, remove any cooking utensils from the burner grate. Push and turn the control knob counter - clockwise to the "IGNITE/HI" position. If the burner does not light, turn the control knob to "OFF". If the smell of gas is detected and the igniter is not functioning, immediately turn the control knob "OFF". Allow 5 minutes for any accumulated gas to dissipate. If the side burner igniter is not functioning, see the following section for match lighting.

TO MATCH LIGHT THE GRILL

If the burner will not light after several attempts then the burner can be match lit. Match light extension rod is located on the inside panel of the door.

TO LIGHT THE MAIN BURNER:

Never substitute regulators and hose assembly for those supplied with the grill. If a replacement is necessary, contact the **manufacturer** for proper replacement. The replacement must be that specified in the manual.

Screw the regulator (type QCC1) onto the tank. Leak check the hose and regulator connections with a soap and water solution before operating the grill.

If you've just attempted to light the burner with the igniter, allow 5 minutes for any accumulated gas to dissipate. Keep your face and hands as far away from the grill as possible.

- 1) Insert a lit match attached to the lighting rod through the cooking grids to the burner (see next page)
- 2) Press the control knob and rotate left to the HI/Light setting, continue to press the knob until the burner ignites. Burner should light immediately.
- 3) If the burner does not light in 4 seconds turn the knob off, wait 5 minutes and try again.

TO MATCH LIGHT THE SIDE BURNER

Hold a lit extended match near the side burner ports, turn the control knob counterclockwise to "IGNITE/HI". Move your hand immediately once the burner is lit. Rotate the control knob to the desired setting.

Keep a spray bottle of soapy water near the gas supply valve and check the connections before each use.

Do not attempt to light the grill if odor of gas is present. Call for service

1-866-984-7455

FLAME CHARACTERISTICS

Check for proper burner flame characteristics.

Burner flames should be blue and stable with no yellow tips, excessive noise, or lifting. If any of these conditions exist call our customer service line. If the flame is yellow, it indicates insufficient air. If the flame is noisy and tends to lift away from the burner, it indicates too much air



Each burner is adjusted prior to shipment; however, variations in the local gas supply may take minor adjustments necessary.

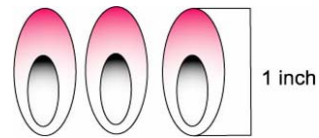

Visually check the burner flames prior to each use. The flames should look like this picture. If they do not, refer to the burner maintenance part of this manual.

Main & Side Burner Lighting Illustration:

Step 1.
Make sure the lid is open



Step 2.
Push and turn main burner or side burner knobs to "IGNITE/HI" position. For main burner, the pilot torch will light; hold for 3-4 seconds until the burner is lit by the pilot torch. For side burner, the burner will be lit immediately.



Step 3.
You may need to try 3 or 4 times to light the burner. After the burner is lit, adjust the knob as desired.



Rear Burner and Searing Main Burner lighting illustration:

Step to Light the Rear Burner:

Push and turn rear burner knob to "IGNITE/ON" and keep pushing for 3-4 seconds. While pushing the knob, simultaneously press electronic igniter for 3 to 4 seconds to light the burner. Once it is lit, release electronic igniter and keep pushing the knob for another 15 seconds to ensure the burner stays lit. If ignition does not occur in 5 seconds, turn the burner knob to OFF, wait 5 minutes and then repeat the lighting procedure above or light by match.



Step to light the Searing Main Burner:

Push and turn searing main burner knob to "IGNITE/ON" and keep pushing for 3-4 seconds. While pushing the knob, simultaneously press electronic igniter for 3 to 4 seconds to light the burner. Once it is lit, release electronic igniter and keep pushing the knob for another 15 seconds to ensure the burner stays lit. If ignition does not occur in 5 seconds, turn the burner knob to OFF, wait 5 minutes and then repeat the lighting procedure above or light by match.



Match Lighting Instruction

1. If the burner will not light after several attempts then the burner can be match lit.
2. If you have attempted to light the main burners with the igniter, allow 5 minutes for any accumulated gas to dissipate.
3. Insert a match into the lighting rod. Ignite the match and insert through the cooking grid to the burner. (As shown below)
4. Press the control knob and rotate it to the "Ignite/HI" setting. The burner should light immediately.
5. If the burner does not light within seconds turn the knob to the "OFF" position, wait 5 minutes and try again.

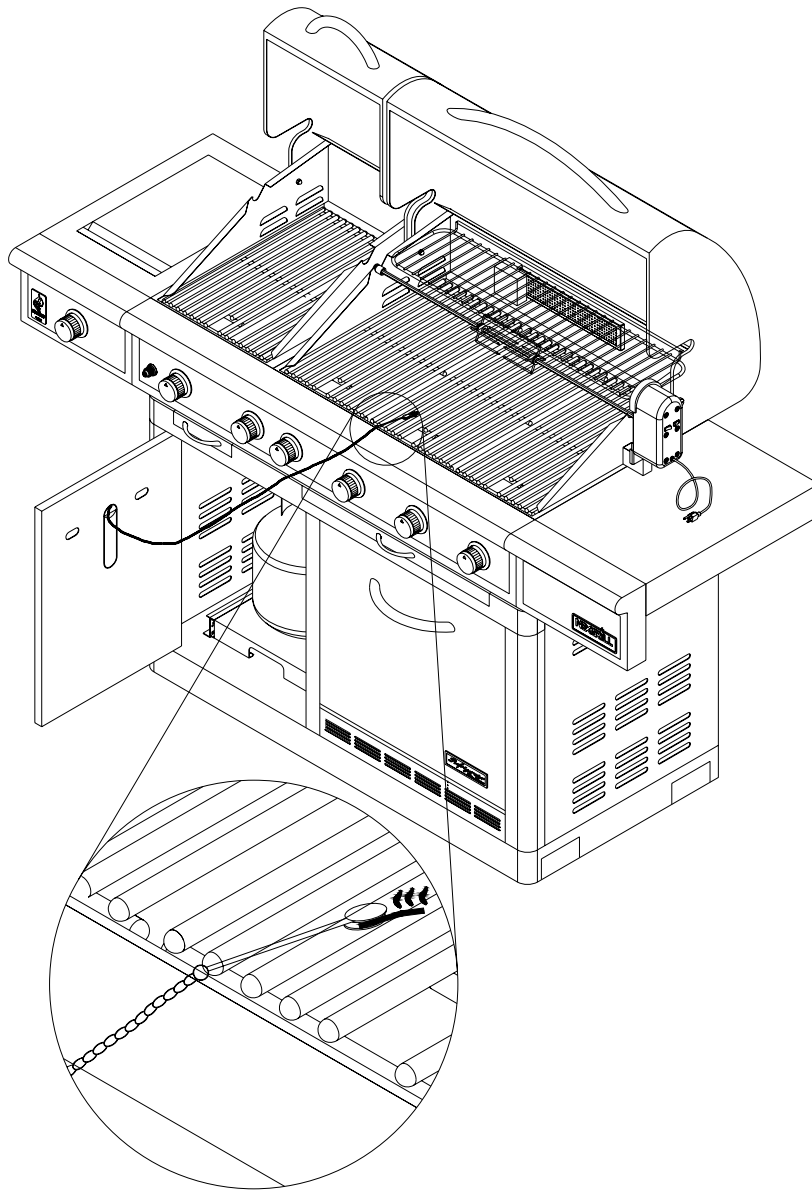

NOTICE

Dear customers:

Thank you for choosing our barbeque grill and hope that you enjoy our product.

Our gas valves and components are preset at the factory to operate on Liquid Propane (LP). If you wish to convert your grill from LP to Natural Gas (NG), we strongly recommend that you hire a professionally trained technician to convert the unit. Please understand that we will not be responsible for any liability, personal injury, or property damage resulting from an improperly converted grill.

We will provide warranty parts for this product after it is converted, however, we will not honor any warranty claims for parts damaged during the conversion of the original LP valves and orifices to NG configuration if the conversion is done improperly.



WARNING – for grill using natural gas (NG)

1. The outdoor cooking gas appliance and its individual shutoff valve must be disconnected from the gas supply piping system during any pressure testing of that system at test pressures in excess of 0.5 psi (3.5kPa).
2. The outdoor cooking gas appliance must be isolated from the gas supply piping system by closing its individual manual shutoff valve during any pressure testing of the gas supply piping system at test pressures equal to or less than ½ psi (3.5 kPa).

TOOLS NEEDED: A- 6mm & 7mm LONG SOCKET & DRIVER
B-CROSSHEAD SCREWDRIVER
C-FLAT-HEAD SCREWDRIVER
D-ADJUSTABLE WRENCH
E-10mm OPEN END WRENCH
F-VICE GRIPS

NG Conversion Kit: NG regulator
NG hose w/quick connector
NG brass connector
NG regulator hose
NG regulator clamp

* Not provided, NG Conversion Kit sold separately.

NG Orifices:

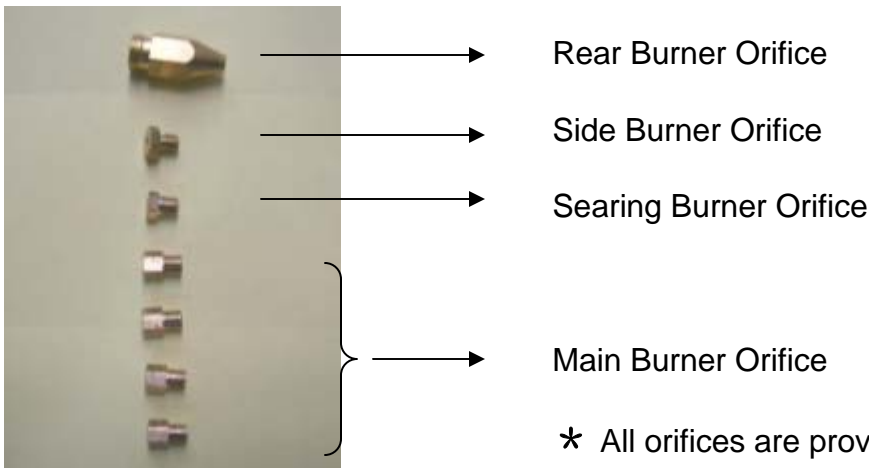

* All orifices are provided in NG Orifices Pack.

Step 1: Replace Main Burner Orifice

- a. Remove cooking-grids and flame tamers.
- b. Remove the main burner from the firebox by loosening the screw near the back wall of the firebox.
- c. Locate LP-Orifice at access hole in front wall of fire box. Replace LP orifice with NG orifice (1.62 mm) in the NG orifices pack.
- d. Use a 6mm socket with driver to remove LP orifice & replace with NG orifice.

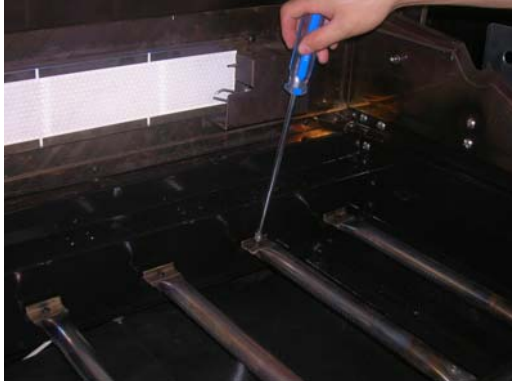

Step 2: Replace Side Burner Orifice

- a. Remove side burner cooking grate and burner.
- b. Locate & replace side burner orifice using a 7mm socket (refer to below illustration).
- c. Restore side burner and cooking grate.



Step 3: Replace Rear Burner Orifice

- a. Remove rear baffle from bowl Assembly.
- b. Grasp brass elbow with vice grip.
- c. With 10 mm wrench, remove LP orifice and replace with NG orifice (1.55mm).
- d. Restore rear baffle.



Step 4: Replace Searing Burner Orifice

- a. Remove front 2 Phillips screws,
- b. Remove 3 Phillips screws and push the igniter towards the left and take off the sear burner brace.
Remove the Searing Burner by lifting it towards rear and upward.
- c. Locate and remove the LP orifice on the valve inside the control panel with a hex socket bit driver.
- d. Replace with NG (2.1mm) orifice and reverse the above steps for reinstallation.
IMPORTANT: ensure all parts & screws are secured tightly and in its original position/location.

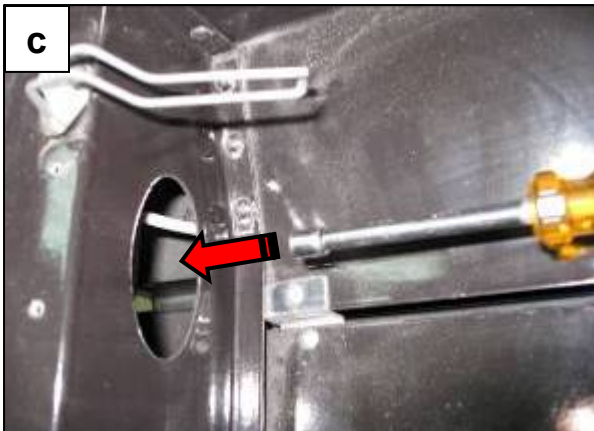
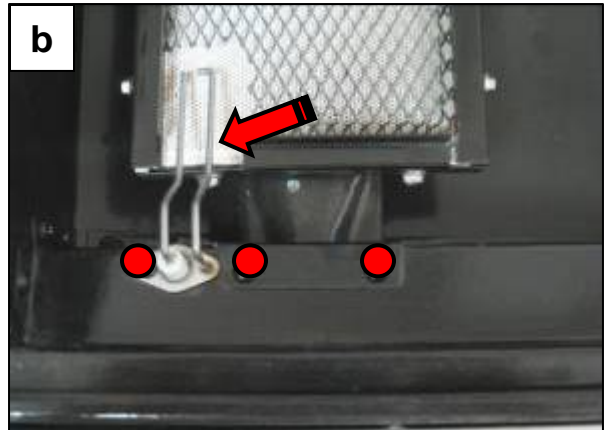
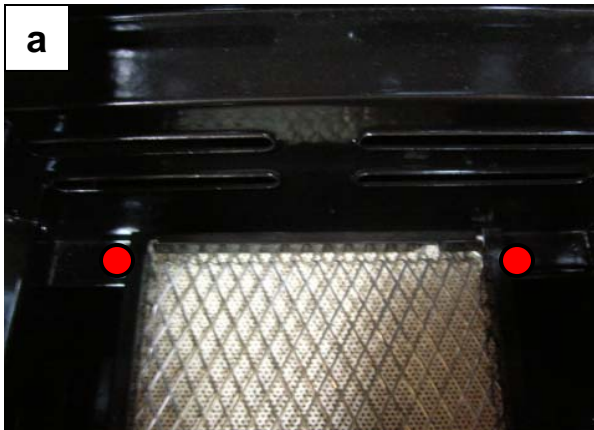

Step 5: Remove Regulator

- a. Use adjustable wrench to remove existing LP gas regulator and hose assembly.
- b. If you are replacing an existing natural gas grill, the supply hose that supplied natural gas to the old grill will work with your new grill.
- c. Replace the LP gas regulator and hose assembly with a natural gas supply hose and regulator (not supplied with the grill). Follow installation instructions as supplied by the manufacturer. The regulator might not be necessary. You should contact the local natural gas company to determine if the gas pressure to the property is regulated (has a regulator in the system). If so, then another regulator is not necessary.
- d. A new hose is not supplied with this grill so as not to overcharge the consumer for unnecessary parts.

Step 6: Check for Gas leak

Make sure you conduct a leak test before operating the grill after conversion. Please refer to Page 16 on the manual on how to test for gas leak.

Step 7: Adjustment of Control Valves for Main Burner and Side Burner

- a. Remove all control-knobs with 5/32" Allen wrench (provided).
- b. Adjust gas valve through access hole at knob-bezel by inserting a flat-head screw driver. Turn the screw driver clockwise (to tighten) until it stops. (Not: it may already be fully turned so it will not turn further). Then turn it counterclockwise (to loosen) for one full revolution (360 deg, per revolution).
- c. Adjust gas valve on the side burner.
- d. Restore & secure knobs.



- **TO USE MOTOR SAFELY, PLEASE READ WARNING PRIOR TO USE**

ROTISSERIE DRIVE MOTOR

USE ONLY FOR OUTDOORS. DO NOT EXPOSE TO RAIN.

 **CAUTION:** TO ENSURE CONTINUED PROTECTION AGAINST RISK OF ELECTRIC SHOCK, CONNECT TO PROPERLY GROUNDED OUTLETS ONLY, TO REDUCE THE RISK OF ELECTRIC SHOCK, KEEP EXTENSION CORD CONNECTION DRY AND OFF THE GROUND.

WARNING

ELECTRICAL GROUNDING INSTRUCTIONS This appliance (rotisserie motor) is equipped with a plug and should be plugged directly into a properly grounded receptacle. **DO NOT** cut or remove the grounding prong from this plug.

Keep the rotisserie motor electric cord away from the heated surfaces of the grill. When not in use remove and store the motor in a dry location.

This motor is set for 120V AC & 60Hz, 4W, 40mA, If voltage is exceeded, motor will be burn out.

Rotisserie Operating illustrations:

1. Place rotisserie motor onto the motor bracket, plug into a properly grounded outlet. Ensure that the rotisserie spit rod is inserted into the motor prior to turning on the motor.



Insert rotisserie spit rod



120V AC 60Hz, 4W, 40mA



2. When finished using rotisserie motor, switch to "off" position and unplug.



IMPORTANT: READ THE FOLLOWING PRIOR TO CONNECTING POWER AND USE

To reduce the risk of fire, electrical shock or injury when using this unit, follow basic precaution, including the following.

Remove all packages before using this unit.



Before the refrigerator is used, it must be PROPERLY POSITIONED, LEVEL and installed as described in this manual. READ THIS MANUAL CAREFULLY.



PRODUCT CERTIFIED UNDER UL471



WARNING

1. Use two or more people to move and install this unit. Failure to do so can result in back or other injury.
2. To ensure proper ventilation for your refrigerator, the front of the unit must be completely unobstructed. Choose a well-ventilated area with temperatures above 40°F (5°C) and below 105°F (40°C). This unit must be installed in an area protect from the element.
3. The refrigerator must be installed with all electrical connections in accordance with state and local codes. A standard electrical supply (**115V AC only , 60 Hz**), properly grounded in accordance with the National Electrical Code and local codes and ordinances is required.
4. Do not kink or pinch the power supply cord of refrigerator.
5. The fuse (or circuit breaker) size should be 15 amperes.
6. It is **important for the refrigerator to be level in order to work properly**. You may need to make several adjustments to level it.
7. Never allow children to operate, play with or crawl inside the refrigerator.
8. Do not use solvent-based cleaning agents or abrasives on the interior. These cleaners my damage or discolor the interior.
9. Do not use this apparatus for other than its intended purpose.

Refrigerator Installation Instruction

INSTALLATION INSTRUCTIONS

➤ Before Using Your Unit

- Remove the exterior and interior packing.
- Before connecting the unit to the power source, let it stand upright for approximately 2 hours. This will reduce the possibility of a malfunction in the cooling system from handling during transportation.
- Clean the interior surface with lukewarm water using a soft cloth.

➤ Setting the Temperature Control

- Your unit has only one control for regulating the temperature in the compartment. The temperature control is located on the upper side of the compartment.
- The first time you turn the unit on, set the temperature control to "5".
- The range of the temperature control is from position "OFF" to "5". **"1" is the warmest and "5" is the coolest.** After 24 to 48 hours, adjust the temperature control to the setting that best suits your needs. The setting of "3" should be appropriate for normal use.
- To turn the appliance off, turn the temperature control to "OFF".

➤ Electrical Connection

- Turning the temperature control to "OFF" position stops the cooling cycle but does not shut off the power to the unit.
- If the unit is unplugged, has lost power, or is turned off, you must wait 3 to 5 minutes before restarting the unit. If you attempt to restart before this time delay, the unit will not start.

➤ Food Storage

- Use plastic wrap to keep food and place evenly on wire rack or drawer.
- Keep hot food cool down before put into this refrigerator for energy saving.
- Do not open door or drawer frequently.
- Keep gap between foods inside refrigerator.
- Keep food dry before storage.

➤ Installing Your Unit

- Remove food from refrigerator when power is out.
- Place your unit on a floor that is strong enough to support the unit when it is fully loaded. To level your unit, adjust the leveling legs at the bottom of the unit.
- Locate the unit away from direct sunlight. Direct sunlight may affect the acrylic coating, and heat sources may increase electrical consumption. Extremely cold ambient temperature may also cause the unit not to perform properly.
- Plug the unit into an exclusive, properly installed-grounded wall outlet. Do not cut or remove the third (ground) prong from the power cord under any circumstances. Any questions concerning power and/or grounding should be directed toward a certified electrician or an authorized products service center.
- After plugging the appliance into a wall outlet, allow the unit to cool down for 2-3 hours before placing food in the refrigerator compartment.

Refrigerator Technical Data

ITEM	DATA
Voltage (V)	110
Frequency (Hz)	60
Current (A)	1.45
Input Wattage (W)	80
Consumptions (KW.h/24h)	0.9
Volume (cu.ft.)	2.1
Dimension (mm)	520*508*520
Refrigerant	R134a
Refrigerant Weight (g)	29
High Pressure (psig)	218
Low Pressure (psig)	88
Net Weight (kg)	30.5
Insulation	PU

STAINLESS STEEL

There are many different stainless steel cleaners available. Always use the mildest cleaning procedure first, scrubbing in the direction of the grain. Specks of grease can gather on the surfaces of the stainless steel and bake on to the surface and give the appearance of rust. For removal use a mild abrasive pad in conjunction with a stainless steel cleaner.

GRILL GRATE

The easiest way to clean the grill is immediately after cooking is completed and after turning off the flame. Wear a barbeque mitt to protect your hand from the heat and steam. Dip a brass bristle barbeque brush in water and scrub the hot grill. Dip the brush frequently in the bowl of water. Steam, created as water contacts the hot grill, assists the cleaning process by softening any food particles. If the grill is allowed to cool before cleaning, cleaning will be more difficult.

ENSURE THAT THE GAS SUPPLY AND THE KNOBS ARE IN THE "OFF" POSITION. MAKE SURE BURNER ARE COOL BEFORE REMOVAL.

GRILL BURNERS

Extreme care should be taken when moving a burner as it must be correctly centered on the orifice before any attempt is made to relight the grill. Frequency of cleaning will depend on how often you use the grill.

MAIN GRILL BURNER CLEANING

Ensure the gas supply is off and the knobs are in the "OFF" position. Make sure the grill is cool. Clean the exterior of the burner with a wire brush. Clear stubborn scale with a metal scraper. Clear any clogged ports with a straightened paper clip. Never use a wooden toothpick as it may break off and clog the port. Please note if insects or other obstructions are blocking the flow of gas through the burner, and if so you will need to call our customer service line 1-866-984-7455.

GREASE TRAY CLEANING:

The grease tray should be emptied and wiped down periodically and washed with a mild detergent and warm water solution. A small amount of sand may be placed in bottom of grease tray to absorb the grease. Check the grease tray frequently, do not allow excess grease to accumulate and overflow out of the grease tray.

BURNER CLEANING:

1. Turn off the gas supply, and make sure all the knobs are in the "OFF" position.
2. Wait for the grill to cool.
3. Clean the exterior of the burner with a wire brush. Use a metal scraper to stubborn stains.
4. Clear clogged port with a straightened paper clip. Never use a wooden toothpick as it may break off and clog the port
5. If inserts or other obstructions are blocking the flow of gas through the burner, call customer service at 1-866-984-7455

HOW TO REPLACE MAIN BURNER

Step 1. Insert the burner into the orifice. Make sure the orifice spud is inside the burner venturi .



Step 2. Secure the main burner on the back wall of fire box with 1 screw.



STAINLESS STEEL :

There are many different stainless steel cleaners available. Always use the mildest cleaning procedure first, scrubbing in the direction of the grain. Do not use steel wool as it will scratch the surface. To touch up noticeable scratches in the stainless steel, sand very lightly with dry 100 grit emery paper in the direction of the grain.

CAUTION:

1. Keep outdoor cooking gas appliance area clear and free from combustible materials, gasoline and other flammable vapors and liquids.
2. Do not obstruct the flow of combustible and ventilation air.
3. Keep the ventilation openings of the cylinder enclosure free and clear from debris.

REFRIGERATOR

➤ Operating Your Unit

- Your unit has only one control for regulating the temperature in the compartment. The temperature control is located on top side of the compartment.
- The first time you turn the unit on, set the temperature control to “5”.
- The range of the temperature control is from position “OFF” to “5”. After 24 to 48 hours, adjust the temperature control to the setting that best suits your needs. The setting of “3” should be appropriate for normal use.
- To turn the appliance off, turn the temperature control to “OFF”.

NOTE:

- Turning the temperature control to “OFF” position stops the cooling cycle but does not shut off the power to the unit.
- If the unit is unplugged, has lost power, or is turned off, you must wait 3 to 5 minutes before restarting the unit. If you attempt to restart before this time delay, the unit will not start.

CAUTION:

- Do not use boiling water because it may damage the plastic parts. In addition, never use a sharp or metallic instrument to remove frost as it may damage the cooling system and will void the warranty. We recommend using a plastic scraper.

➤ Cleaning Your Unit

- Turn the temperature control to “OFF”, unplug the unit, and remove the food, shelf, and tray.
- Wash the inside surfaces with a warm water and baking soda solution. The solution should be about 2 tablespoons of baking soda to a quart of water.
- Wash the shelf and tray with a mild detergent solution.

- The outside of the unit should be cleaned with mild detergent and warm water.
- Wring excess water out of the sponge or cloth before cleaning the area of the controls, or any electrical parts.
- Wash the outside cabinet with warm water and mild liquid detergent. Rinse well and wipe dry with a clean soft cloth.

CAUTION:

- Failure to unplug the unit could result in electrical shock or personal injury.

➤ Power Failure

- Most power failures are corrected within a few hours and should not affect the temperature of your unit if you minimize the number of times the door is opened. If the power is going to be off for a longer period of time, you need to take the proper steps to protect your food.

➤ Vacation Time

- **Short Vacations:** Leave the unit operating during vacations of less than three weeks.
- **Long Vacations:** If the appliance will not be used for several months, remove all food and unplug the power cord. Clean and dry the interior thoroughly. To prevent odor and mold growth, leave the door open slightly: blocking it open if necessary.

➤ Moving Your Unit

- Remove all the food.
- Securely tape down all loose items inside your unit.
- Turn the leveling legs up to the base to avoid damage.
- Tape the door shut.
- Be sure the unit stays secure in the upright position during transportation. Also protect the outside of unit with a blanket, or similar item.

➤ **Energy Saving Tips**

- Let hot foods cool to room temperature before placing in the unit. Overloading the unit forces the compressor to run longer.
- Be sure to wrap foods properly, and wipe containers dry before placing them in the unit. This cuts down on frost build-up inside the unit.
- Unit storage bin should not be lined with aluminum foil, wax paper, or paper toweling. Liners interfere with cold air circulation, making the unit less efficient.
- Organize and label food to reduce door openings and extended searches. Remove as many items as needed at one time, and close the door as soon as possible.

Troubleshooting

SPIDER AND INSECT WARNING

Checking and cleaning burner/ venturi tubes for insects and insect nests. A clogged tube can lead to a fire beneath the grill.

Spiders and small insects occasionally spin webs or make nests in the grill burner tubes during transit and warehousing. These webs can lead to gas flow obstruction which could result in a fire in and around burner tubes. This type of fire is known as "FLASH-BACK" and can cause serious damage to your grill and create an unsafe operating condition for the user.

Although an obstructed burner tube is not the only cause of "FLASH-BACK", it is the most common cause.

To reduce the chance of "FLASH-BACK", you must clean the burner tubes before assembling your grill, and at least once a month in late summer or early fall when spiders are most active. Also perform this burner tube cleaning procedure if your grill has not been used for an extended period of time.

WHEN TO LOOK FOR SPIDERS

You should inspect the burners at least once a year or immediately after any of the following conditions occur:

1. The smell of gas in conjunction with the burner flames appearing yellow.
2. The grill does not reach temperature.
3. The grill heats unevenly.
4. The burners make popping noises.

BEFORE CALLING FOR SERVICE

If the grill does not function properly, use the following check list before contacting your dealer for service. You may save the cost of a service call.

PREHEATING: The grill lid should be in a closed position during the preheat time period. It is necessary to preheat the grill before cooking certain foods, depending on the type of food and the cooking temperature. Food that requires a high cooking temperature needs a pre-heat period of five minutes; food that requires a lower cooking temperature needs only a period of two to three minutes.

COOKING TEMPERATURES

High setting-Use this setting for fast warm-up, for searing steaks and chops, and grilling.

Low setting-Use this setting for all roasting, baking, and when cooking very lean cuts such as fish.

These temperatures vary with the outside temperature and the amount of wind.

Cooking with in-direct Heat: You can cook poultry and large cuts of meat slowly to perfection on one side of the grill by indirect heat from the burner on the other side. Heat from the lighted burner circulates gently throughout the grill, cooking the meat or poultry without any direct flame touching it. This method greatly reduces flare-ups when cooking extra fatty cuts, because there is no direct flame to light the fats and juices that drip down during cooking.

CAUTION: If burners go out during operation, close gas supply at source, and turn all gas valves off. Open lid and wait five minutes before attempting to re-light (this allows accumulated gas fumes to clear).

CAUTION: Should a grease fire occur, close gas supply at source, turn off all burners and leave lid closed until fire is out.

CAUTION: DO NOT attempt to disconnect any gas fitting while your grill is in operation. As with all appliances, proper care and maintenance will keep them in top operating condition and prolong their life. Your gas grill is no exception.

You can solve many common problems easily, saving you the cost of a possible service call. Try the suggestions below to see if you can solve the problem before calling the service.

PROBLEM (Grill)	SOLUTION
When attempting to light my grill, it will not light immediately.	<ul style="list-style-type: none"> • Make sure you have a spark while you are trying to light the burner. • Make sure that the wire is connected to the electrode assembly. • Clean wire (s) and / or electrode with rubbing alcohol and a clean swab. Wipe with a clean cloth. • Check to see if the other burners operate. If so. Check the gas orifice on the malfunctioning burner for an obstruction.
Rotisserie burner will not light.	<ul style="list-style-type: none"> • Check to see if debris is blocking the electrode. • Check to see if there is a spark that jumps to the burner from the electrode. If no spark is seen, check the battery located inside the igniter box. • Does the infrared back burner light when attempting to light with a match ? If not, check to ensure the gas is on.
Regulator makes noise.	<ul style="list-style-type: none"> • Vent hose on the regulator may be plugged or regulator may be faulty. • Ensure the vent hole on the regulator is not obstructed. Clear the hole, close the gas control valves. Wait ten minutes and re-start. • Check your flames for proper performance. If the flames are not correct, replace regulator.
Full size cover does not fit the grill.	<ul style="list-style-type: none"> • Cover may be incorrect for your grill. It may be a tight fit. Ensure the cover is the correct length for your grill. Measure it left to right. Compare to the grill's measurement. • Compare the location and size of the hood portion of the cover to your grill. • Spread the cover and allow it to relax, preferably in warm sunlight or in a warm room. • For grill with a side shelf bunch the cover like a sock, put on left to right.
Rotisserie motor will not turn.	<ul style="list-style-type: none"> • Ensure the motor is connected to a properly grounded power supply. • Ensure the on/off switch is in the on position. • Ensure that the spit is fully inserted into the rotisserie motor. • Ensure that the load does not exceed the 40 pound operational capacity. • Ensure that there is no encumbrance or drag.
Grill takes a long time to preheat.	<ul style="list-style-type: none"> • Normal preheat 500-600degrees, takes about 10-15 min. • Cold weather and wind may affect preheat time. • If you are using volcanic rock or briquettes, they would increase the preheat time and maximum temperature.

<p>Grill only heats to 200-300 degrees.</p>	<ul style="list-style-type: none"> • Check to see if the fuel hose is bent or kinked. • Make sure the grill area is clear of dust. • Make sure the burner and orifices are clean. • Check for spiders and insects. • The regulator has a safety device that restricts the flow of gas in the event of a leak. This safety device can be triggered without a gas leak. • To reset the safety device, turn off all burners and close the LP tank valve. To Disconnect the regulator from the LP tank and wait one minute. Reconnect the regulator to the LP tank and slowly open the LP tank valve until the valve is fully open. Light all burners and observe the temperature.
<p>Burner flames are not light blue.</p>	<ul style="list-style-type: none"> • Too much or not enough air for the flame. • Elevation is the principal cause, however cold weather can affect the mixture. Burner adjustment may be required. • Grill is in a windy location.
<p>PROBLEM (Refrigerator)</p>	<p>SOLUTION</p>
<p>Unit does not operate.</p>	<ul style="list-style-type: none"> • Not plugged in. • The circuit breaker tripped or a blown fuse. • The unit temperature control is set at "OFF" position.
<p>Turns on and off frequently.</p>	<ul style="list-style-type: none"> • The ambient temperature is hotter than normal. • A large amount of food has been added to the unit. • The door is opened too often. • The door is not closed completely. • The temperature control is not set correctly. • The door gasket does not seal properly.
<p>The unit is vibrating.</p>	<ul style="list-style-type: none"> • Check to assure that the unit is level.
<p>The unit seems to make too much noise.</p>	<ul style="list-style-type: none"> • The rattling noise may come from the flow of the refrigerant, which is normal. • As each cycle ends, you may hear gurgling sounds caused by the flow of refrigerant in your unit. • Contraction and expansion of the inside walls may cause popping and crackling noises. • The unit is not level.

Exploded View

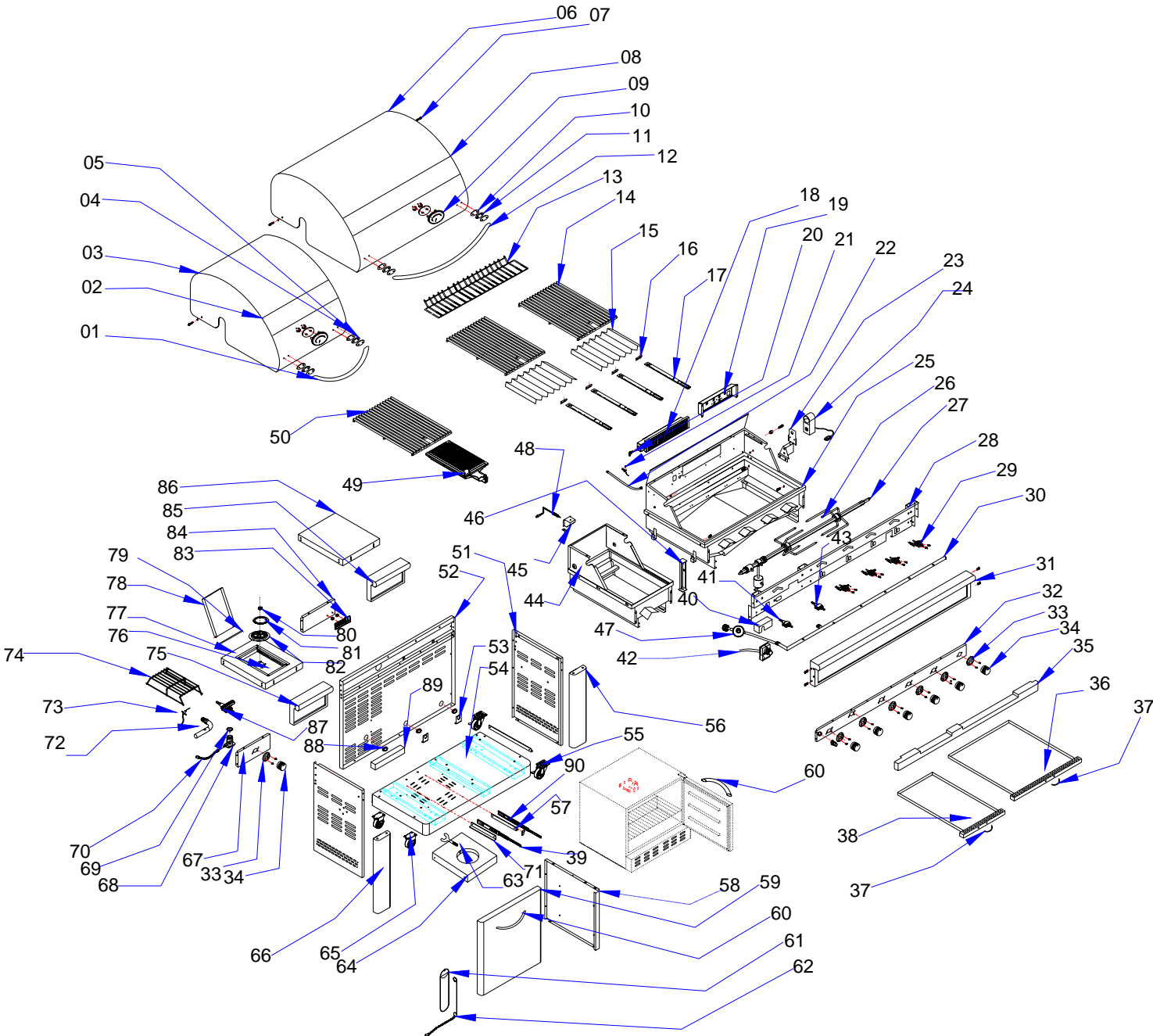

Part List

No.	Part (Description)	QTY	No.	Part (Description)	QTY
1	Small main lid handle tube	1	32	Main control panel trim piece	1
2	Small main lid trim piece	1	33	Bezel	7
3	Small main lid	1	34	Control knob	7
4	Small main lid handle heat insulating spacer	4	35	Cart frame, front	1
5	Small main lid handle seat	2	36	Grease tray	1
6	Main lid	1	37	Grease tray handle	2
7	Main lid screw	2	38	Small main burner grease tray	1
8	Main lid trim piece	1	39	Tank tray slide, left	1
9	Temperature gauge	2	40	Pulse igniter module cover	1
10	Main lid handle heat insulating spacer	4	41	Searing burner gas valve	1
11	Main lid handle seat	2	42	Pulse igniter module	1
12	Main lid handle tube	1	43	Rotisserie gas valve	1
13	Warming rack	1	44	Searing burner bowl assembly	1
14	Main burners cooking grid	2	45	Sear burner thermocouple heat shield	1
15	Flame tamer	2	46	Supporting	1
16	Main burner bracket	4	47	Regulator, LP	1
17	Main burner	4	48	Sear burner igniter wire	1
18	Rotisserie burner	1	49	Sear burner	1
19	Rotisserie burner rear baffle	1	50	Sear burner cooking grid	1
20	Rotisserie orifice w/brass elbow	1	51	Side panel, right	1
21	Rotisserie Burner Igniter Wire	1	52	Back panel	1
22	Rotisserie Burner Flex Gas line	1	53	Refrigerator bracket	1
23	Rotisserie motor bracket	1	54	Bottom panel, LP	1
24	Rotisserie motor	1	55	Swivel caster with brake	2
25	Main burner bowl assembly	1	56	Front trim panel, right	1
26	Spit fork	2	57	Tank tray slide bracket, right	1
27	Spit rod	1	58	Center panel	1
28	Front baffle	1	59	Tank enclosure door	1
29	Main gas valve	4	60	Door handle	2
30	Main manifold	1	61	Lighting rod cover	1
31	Main control panel	1	62	Lighting rod	1

No.	Part (Description)	QTY	No.	Part (Description)	QTY
63	Tank bolt	1			
64	Tank tray	1			
65	Caster	2			
66	Front trim panel, left	1			
67	Side burner control panel trim piece	1			
68	Side burner orifice base	1			
69	Side burner orifice washer	1			
70	Side burner flex gas line	1			
71	Tank tray slide bracket, left	1			
72	Side manifold	1			
73	Side burner igniter wire	1			
74	Side burner cooking grid	1			
75	Side burner control panel	1			
76	Side burner bowl assembly (fire box)	1			
77	Side burner bowl assembly (frame)	1			
78	Side burner lid	1			
79	Side burner lid hinge rod	1			
80	Side burner head	1			
81	Side Burner ring	1			
82	Side burner body	1			
83	Logo	1			
84	Side shelf front trim piece	1			
85	Right side shelf front panel	1			
86	Right side shelf	1			
87	Side gas valve	1			
88	Rubber Grommet	3			
89	Weighted base	1			
90	Tank tray slide, right	1			
91	NG orifices pack	1			
		1			
		1			

HOW TO ORDER REPLACEMENT PARTS

To make sure you obtain the correct replacement part(s) for your gas grill, please refer to the parts list on page 37-38. The following information is required to assure getting the correct part.

- Gas grills model number (see data sticker on grill).
- Part number of replacement part needed.
- Description of replacement part needed.
- Quantity of parts needed.

To obtain replacement parts, contact the dealer from which products was purchased. If dealer service is not available, contact: Nexgrill Industries, Inc. customer service

1-866-984-7455

IMPORTANT

Use only factory authorized parts. The use of any part that is not factory authorized can be dangerous. This will also void your warranty.

Keep this assembly and operating instruction manual for convenient referral, and for replacement parts ordering.

CAUTION

Gas valves are present at the factory (valve assembly will be marked accordingly). If you wish to convert at some later date, be sure to contact your gas supplier or grill dealer before making the conversion.

Different orifices must be installed when converting from one type of gas to another. You will also need a data plate indicating what type of gas is used by the grill.

Grill Hints

The doneness of meat, whether rare, medium, or well done, is affected to a large degree by the thickness of the cut. Expert chefs say it is impossible to have a rare doneness with a thin cut of meat.

The cooking time is affected by the kind of meat, the size and shape of the cut, the temperature of the meat when cooking begins, and the degree of doneness desired.

When defrosting meats it is recommended that it be done overnight in the refrigerator as opposed to a microwave. This in general yields a juicier cut of meat.

Use a spatula instead of tongs or a fork to

turn the meat, as a spatula will not puncture the meat and let the juices run out.

To get the juiciest meats, add seasoning or salt after the cooking is finished on each side and turn the meat only once (juices are lost when the meat is turned several times). Turn the meat just after the juices begin to bubble to the surface.

Trim any excess fat from the meat before cooking. To prevent steaks or chops from curling during cooking, slit the fat around the edges at 2-inch intervals.

DO NOT LEAVE THE GRILL UNATTENDED WHILE COOKING.

Grill Cooking Chart

FOOD	WEIGHT OR THICKNESS	HEAT SETTING	APPROXIMATE TIME	SPECIAL INSTRUCTIONS AND TIPS
VEGETABLES				Slice. Dot with butter or margarine. Wrap in heavy -duty foil. Grill, turning occasionally
Fresh Beets Carrots Turnips		Medium	12 to 20 minutes	Grill, turning once. Brush occasionally with melted butter or margarine.
Onion	1/2 inch slices	Medium	8 to 20 minutes	Season with Italian dressing, butter, or margarine.
Potatoes Sweet White	Whole 6 to 8 ounces	Medium High	40 to 60 minutes 45 to 60 minutes	Wrap individually in heavy - duty foil. Grill, rotating occasionally.
Frozen Asparagus Peas Green beans Sprouts		Medium	15 to 30 minutes	Dot with butter or margarine. Wrap in heavy -duty foil. Grill, turning occasionally.
French fries		Medium	15 to 30 minutes	Place in aluminum foil pan. Grill, stirring occasionally
MEATS BEEF Hamburgers	1/2 to 3/4 inch	Medium	10 to 18 minutes	Grill, turning once when juices rise to the surfaces. Do not leave hamburgers unattended since a flare-up could occur quickly. Cook to internal temperature of 160 degrees
Tenderloin		High	8 to 15 minutes	
Rare	1 inch	High	8 to 14 minutes	Trim edges. Grill, turning once.
Medium	1-1/2 inch 1 inch 1-1/2 inch	High Medium to High	11 to 18 minutes 12 to 22 minutes 16 to 27 minutes	
Well - done	1 inch 1-1/2 inches	Medium Medium	18 to 30 minutes 16 to 35 minutes	
LAMB Chop & Steaks				Trim edges. Grill, turning once.
Rare	1 inch 1-1/2 inch	Medium to High	10 to 15 minutes 14 to 18 minutes	
Medium	1 inch 1-1/2 inch	Medium to High	13 to 20 minutes 18 to 25 minutes	

Grill Cooking Chart *continued*

FOOD	WEIGHT OR THICKNESS	HEAT SETTING	APPROXIMATE TIME	SPECIAL INSTRUCTIONS AND TIPS
PORK Chops	1 inch	Medium	20 to 30 minutes	Trim edges. Grill, turning once. Cook to desired doneness.
Well -done	1 -1/2 inches	Medium	30 to 40 minutes	
Ribs		Medium	30 to 40 minutes	Grill, turning occasionally. During last few minutes brush with barbecue sauce. Turn several times.
Ham steaks (precooked)	1 inch slices	High	4 to 8 minutes	Trim edges. Grill, turning once.
Hot dogs		Low	5 to 10 minutes	Slit skin. Grill, turning once.
POULTRY	2 to 3 pounds	Low or Medium	Up to 1 hour	Place skin side up. Grill, turning and brushing frequently with melted butter, margarine, oil or marinade.
Breasts well -done		Medium	30 to 45 minutes	Marinate as desired.
FISH AND SEAFOOD Halibut Salmon Swordfish	3/4 to 1 inch	Medium to High	8 to 15 minutes	Grill, turning once. Brush with melted butter, margarine or oil to keep moist.
Whole Catfish Rainbow trout	4 to 8 ounce	Medium to High	12 to 20 minutes	Grill, turning once. Brush with melted butter, margarine or oil. Brush with melted butter and lemon juice.

BBQ SALMON

2 large salmon steaks
2 tbs. Oil
Salt & pepper
2 oz. thin bacon slices
2 tbs. Butter
1 tbs. Lemon juice
Spring of parsley
Lemon wedges

Preheat the BBQ.

Brush the steaks with oil and season with salt and pepper. Place on BBQ grill and cook for 10 minutes, turning steaks over halfway cooking time.

Meanwhile fry the bacon in a pan on the side burner. Drain on paper towels. Meld the butter in a small saucepan taking care not to discolor it. Arrange the fish and bacon on serving plates. Pour the butter over and sprinkle with lemon juice. Garnish with parsley springs and lemon wedges. Serve with boiled potatoes tossed in butter and sprinkled with chopped parsley and a crisp lettuce salad.

Note: Substitute catfish, halibut or cod for salmon.

BAKED CHILI CORN

6 medium ears corn, husked
3 tbs. Butter or margarine, melted
Dash ground cumin
Dash ground coriander

About ½ hour before cooking, turn the butter on for grill. Place each corn on a heavy-duty foil. In a bowl, combine remaining ingredients. Mix well. Brush 1-1/2 tsp. Butter mixture over each ear. Close foil and fold up ends to seal. Place on grill. Cook, turning packets occasionally 10 to 12 minutes or until cooked through.

TANGY SEAFOOD KABOBS

1 lb. Large shrimp, shelled & deveined
¾ lbs. sea scallops
2/3 c. chili sauce
¼ c. cider vinegar

butter and sprinkled with chopped parsley and a crisp lettuce salad.

In medium bowl, combine shrimp and scallops. In small bowl combine chili sauce and next six ingredients. Pour over seafood. Toss to coat. Cover, refrigerate 2 hours.

3 tbs. chopped parsley
1 tbs. vegetable oil
1 tbs. Worcestershire sauce
½ tsp. prepared horseradish
1 cove garlic, minced
1 20 oz. Can pineapple chunks in juice, drained half hour before cooking, turn the burner to the grill on full. Drain seafood reserving marinade. On each of twelve 10" skewers, thread 2 shrimps and 2 scallops, alternating with pineapple chunks. Place skewers on grill. Cook 7-10 minutes, often basting and turning.

PORK CHOPS

4 Pork chops
Marinade
1 large onion
2 tbs. lemon juice or vinegar
2 tbs. oil
½ tsp. powdered mustard
2 tsp. Worcestershire sauce
½ tsp. freshly ground black pepper
1 tsp. sugar
½ tsp. paprika
1 clove garlic

Peel, grate onion, and add rest of the ingredients except the pork chops. Mix well. Pour over chops and marinate one hour in a cool place. Turn the BBQ grill on full. Heat 10 minutes.

BBQ the chops brushing with the marinade occasionally. Serve with mixed salad, dressed with vinaigrette flavored with fresh dill.

BARBECUED LONDON BROIL

4 to 6 servings
¾ c. Italian dressing
1 tsp. Worcestershire sauce
1 tsp. dry mustard
¼ tsp. thyme, crushed
1 medium onion, sliced
1 pound flank steak, scored
2 tbs. butter, melted

Combine first 4 ingredients, add onion and marinade flank steak with it. Refrigerate at least 4 hours or overnight. Remove steak and grill on your preheated BBQ grill. Grill 5 to 7 minutes on each side basting frequently with the marinade. In the meantime sauté onions from the marinade in butter in a skillet on your side burner for 3 minutes. To serve, slice steak diagonally into thin slices, sprinkle onions over top. Garnish with vegetable kabobs.

BARBECUED POTATOES and CHEESE

1-1/2 cups shredded cheddar cheese
1 can (10-3/4 oz.) condensed cream of mushroom soup
1/3 cup milk
2 tbs. barbecue sauce
¼ tsp. oregano
¼ tsp. salt
1/8 tsp. pepper
4 cups thinly sliced potatoes (4 medium-sized potatoes)

Preheat grill. Combine cheese, condensed soup, milk, BBQ sauce, oregano, salt and pepper in a large mixing bowl. Stir in potatoes until well coated. Turn into well buttered 1-1/2 quart rectangular baking dish. Cover dish with aluminum foil. Bake covered 25 minutes on medium with the lid of your BBQ grill closed. Remove foil and continue baking 15 minutes longer or until potatoes are tender. Let stand 5 minutes before serving.

VEGETABLE KABOBS

- 3 medium-sized zucchini
- 12 cherry tomatoes
- 12 fresh mushrooms
- Grated Parmesan cheese

Parboil whole zucchini 5 minutes on your side burner or until just tender. Drain and cut into 1/2 inch slices. Thread zucchini, tomatoes and mushrooms alternately on each of six skewers. Brush with marinade made of Italian dressing, Worcestershire sauce, mustard and thyme. Grill 5 to 7 minutes turning and basting occasionally. Sprinkle liberally with Parmesan cheese.

FAJITAS

- 1-1/2 lb. flank steak or boned chicken breasts
- 2 tbs. oil
- 1/2 cup lime juice
- 1/2 tsp. salt
- 1/2 tsp. celery salt
- 1/4 tsp. garlic powder
- 1/2 tsp. pepper
- 1/4 tsp. oregano
- 1/4 tsp. cumin
- Flour tortillas lemon

Pound flank steak to 1/4 inch thickness or flatten chicken breasts. Mix oil, lime juice and seasonings in a zip lock bag. Add meat and shake bag to coat the meat. Refrigerate overnight or at least 6 to 8 hours. Wrap tortillas in foil. Remove meat from marinade. Cook on a pre-heated gas grill for 5 to 8 minutes on each side. While meat is cooking, heat tortillas on grill. Slice meat across grain in thin slices. Place on hot platter. Squeeze lemon juice over. Wrap meat and any of the following toppings in tortillas: chopped tomatoes, guacamole, sour cream, taco sauce.

BEEF AND LAMB KABOBS

- Serve 4
- 1/2 lb. boneless sirloin or beef cut into 1" cubes
- 1/2 lb. boneless loin of lamb cut into 1" cubes
- 2/3 c. water, divided
- 1/4 c. chopped onion
- 2 tbs. soy sauce
- 1/4 c. vegetable oil, divided
- 1 tbs. dark brown sugar
- 1 tbs. fresh lemon juice
- 2 cloves garlic, minced
- 1/4 tsp. ground cumin
- 1/4 tsp. ground coriander
- 1/4 tsp. ground turmeric
- 1/8 tsp. ground red pepper
- 1/8 tsp. ground ginger
- 1 red pepper cut into chunks
- 1 large banana, cut into chunks
- 8 small mushrooms
- 1/3 c. smooth peanut butter

In blender, process 1/3 c. water, onion, soy sauce, 2 tsp. oil and the next 8 ingredients until smooth. Pour over meat cubes and marinate about 4 hours, turning occasionally. Drain and reserve marinade. Onto to four 12" skewers alternately thread meat, pepper, banana and mushrooms. Preheat grill. Brush the kabobs with oil. Grill 7-8 minutes each side.

Bring marinade to boil on the side burner in a saucepan. Add remaining 1/3 c. water and peanut butter. Stir to blend. Heat through. If sauce gets too thick, add 1 tbs. water. Serve sauce with kabobs.

EGGPLANT CAVIAR

- 1 large eggplant
 - 2 tbs. olive oil
 - 2 tbs. wine vinegar
 - 2 tbs. finely chopped onion
 - 1/2 clove garlic, minced
 - 1 medium tomato, chopped salt and pepper
- Roast eggplant on gas grill over medium flame, turning occasionally until thoroughly cooked. This may take 30 minutes. Remove from grill and cool for handling. Strip off the skin and chop eggplant finely. Add all the seasonings. Chill thoroughly and serve on toast.

CHICKEN TANDOORI STYLE

8 large chicken thighs or drumsticks

1 c. plain nonfat yogurt

½ c. lemon juice

2 tsp. salt

½ tsp. cayenne

½ tsp. black pepper

½ tsp. crushed garlic

½ tsp. grated ginger

1 tbs. corn oil

Combine all the ingredients in a large mixing bowl and marinate the chicken for 8 hours in the refrigerator. Drain the chicken and spread on the spit running the rod on the fleshier side of the bone.

Rotis using the rotisserie burner. Cook on medium high heat for 40 minutes basting occasionally with the remainder of the marinade mixture. Serve with sliced onions and lemon wedges.

SPARE RIBS

Marinade:

1 c. soy sauce

½ c. honey

½ c. vinegar

½ c. dry sherry

2 tsp. chopped garlic

2 tsp. sugar

1 c. water

1 chicken bouillon cube

1 can beer for basting sauce

Marinate ribs for 3 hours. Use marinade for basting by adding beer to it. Place pan under the ribs and baste frequently. To cook ribs select lean, meaty ribs and accordion pleat them with your spit. Slide four prong meat hook down the length of spit and tighten. At the beginning of

the rack and to its center, penetrate the second rib with the pointed end of the spit and push it between the meat. Skip a couple and continue the process until the entire rack is accordion pleated. Fasten the second meat hook into the rack. Turn your rotisserie burner on high. Rotis for 50 minutes or until done.

PORK ROAST

Apple cider vinegar basting sauce:

1 c. apple cider vinegar

6 oz. water

½ stick butter

Salt, pepper, parsley and garlic seasoning

2 oz. lemon juice

10 lbs. pork roast

Time: 1-1/2 hours to 2 hours

Bring pork to room temperature before placing it on the spit rod. Place on the rod and test for balance. Light rotis burner. Turn control knob to high. Use the above basting sauce for rotissing.

TURKEY

12 lb. turkey

Beer basting sauce:

1 can beer

12 oz. water

1 stick butter

1 tsp. salt

1 tsp. pepper

½ tsp. garlic flakes

1 tsp. parsley

Thaw the bird completely. Wash inside out. Securely tie the legs and wings. Light rotisserie burner. Turn to high. Combine all the ingredients for basting sauce in a shallow pan. Place it under the turkey 15 to 20 minutes. Cook for approximately 3 hours. The basting sauce combined with turkey drippings makes a delicious gravy.

Nexgrill Industries warrants to the original consumer-purchaser only that this product (*Model #720-0617*) shall be free from defects in workmanship and materials after correct assembly and under normal and reasonable home use for the periods indicated below beginning on the date of purchase. The manufacturer reserves the right to require that defective parts be returned, postage and or freight pre-paid, by the consumer, for review and examination.

- Burners: 3 year **LIMITED** warranty against perforation.
- Grids & Grates*, Electronic Ignition: 1 Year **LIMITED** warranty
- *Does not cover dropping, chipping, scratching, or surface damage.*
- Stainless Steel Parts: 1 Year **LIMITED** warranty against perforation.
- *Does not cover cosmetic issues like surface corrosion, scratches and rust.*
- All other parts: **LIMITED 1 year warranty**
- *Does not cover chipping, scratching, cracking surface corrosion, scratches or rust.*

Upon consumer supplying proof of purchase as provided herein, Manufacturer will repair or replace the parts which are proven defective during the applicable warranty period. Parts required to complete such repair or replacement shall be free of charge to you except for shipping costs, as long as the purchaser is within the warranty period from the original date of purchase. **The original consumer-purchaser will be responsible for all shipping charges of parts replaced under the terms of this limited warranty.** This limited warranty is applicable in the United States only, is only available to the original owner of the product and is *not transferable*. Manufacturer requires reasonable proof of your date of purchase. Therefore, you should retain your sales receipt and/or invoice. Defective or missing parts subject to this limited warranty will not be replaced without registration or proof of purchase. This limited warranty applies to the functionality of the product **ONLY** and does not cover cosmetic issues such as scratches, dents, corrosions or discoloring by heat, abrasive and chemical cleaners or any tools used in the assembly or installation of the appliance, surface rust, or the discoloration of stainless steel surfaces. Surface rust, corrosion, or powder paint chipping on metal parts that does not affect the structural integrity of the product is not considered a defect in workmanship or material and is not covered by this warranty. This limited warranty will not reimburse you for the cost of any inconvenience, food, personal injury or property damage. If an original replacement part is not available, a comparable replacement part will be sent. You will be responsible for all shipping charges of parts replaced under the terms of this limited warranty.

ITEMS MANUFACTURER WILL NOT PAY FOR:

1. Service calls to your home.
2. Repairs when your product is used for other than normal, single-family household or residential use.
3. Damage resulting from accident, alteration, misuse, abuse, fire, flood, acts of God, improper installation, and installation not in accordance with electrical or plumbing codes or use of products not approved by the manufacturer.
4. Any food loss due to product failures.
5. Replacement parts or repair labor costs for units operated outside the United States or Canada.
6. Pickup and delivery of your product.
7. Repairs to parts or systems resulting from unauthorized modifications made to the product.
8. The removal and/or reinstallation of your product.
9. Shipping cost, standard or expedited, for warranty/non warranty and replacement parts.

DISCLAIMER OF IMPLIED WARRANTIES; LIMITATION OF REMEDIES

Repair or replacement of defective parts is your exclusive remedy under the terms of this limited warranty. Manufacturer will not be responsible for any consequential or incidental damages arising from the breach of either this limited warranty or any applicable implied warranty, or for failure or damage resulting from acts of God, improper care and maintenance, grease fire, accident, alteration, replacement of parts by anyone other than Manufacturer, misuse, transportation, commercial use, abuse, hostile environments (inclement weather, acts of nature, animal tampering), improper installation or installation not in accordance with local codes or printed manufacturer instructions.

THIS LIMITED WARRANTY IS THE SOLE EXPRESS WARRANTY GIVEN BY THE MANUFACTURER. NO PRODUCT PERFORMANCE SPECIFICATION OR DESCRIPTION WHEREVER APPEARING IS WARRANTED BY MANUFACTURER EXCEPT TO THE EXTENT SET FORTH IN THIS LIMITED WARRANTY. ANY IMPLIED WARRANTY PROTECTION ARISING UNDER THE LAWS OF ANY STATE, INCLUDING IMPLIED WARRANTY OF MERCHANTABILITY OR FITNESS FOR A PARTICULAR PURPOSE OR USE, IS HEREBY LIMITED IN DURATION TO THE DURATION OF THIS LIMITED WARRANTY.

Neither dealers nor the retail establishment selling this product has any authority to make any additional warranties or to promise remedies in addition to or inconsistent with those stated above. Manufacturer's maximum liability, in any event, shall not exceed the documented purchase price of the product paid by the original consumer. **This warranty only applies to units purchased from an authorized retailer and or re-seller.** NOTE: Some states do not allow an exclusion or limitation of incidental or consequential damages, so some of the above limitations or exclusions may not apply to you; this limited warranty gives you specific legal rights as set for herein. You may also have other rights which vary from state to state.

If you wish to obtain performance of any obligation under this limited warranty, you should write to:
Nexgrill Industries Customer Relations
280 Machlin Court
City of Industry, CA 91789

All consumer returns, parts orders, questions and troubleshooting can be acquired by calling 1-800-913-8999, Monday – Friday, 8am – 5pm PST.