



LG

REFRIGERATOR

SERVICE MANUAL

CAUTION
BEFORE SERVICING THE PRODUCT,
READ THE SAFETY PRECAUTIONS IN THIS MANUAL.

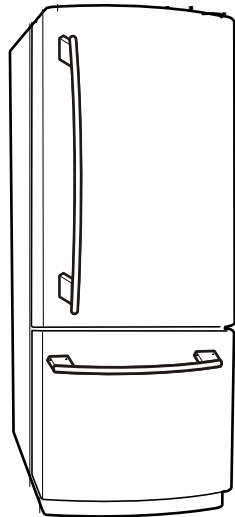

MODELS
LBC22518**

CONTENTS

Safety Precautions	2
1- Specifications	3
2- Parts Identifications	4
3- Disassembly	5
Door.....	5
Door Switch.....	5
Fan and Fan Motor.....	6
Defrost Control Assembly	6
Lamp.....	6
Refrigerator Control Box.....	6
Multi Duct.....	6
4- Adjustment	7
Compressor.....	7
PTC-Starter.....	7
OLP (Overload Protector).....	8
To Remove the Cover PTC.....	8
5- Circuit Diagram	9
6- Troubleshooting	10
Compressor and Electric Components.....	10
PTC and OLP	11
Other Electrical Components.....	12
Service Diagnosis Chart.....	13
Refrigeration Cycle.....	14
7- Operation Principle and Repair Method of Ice Maker	16
8- Description of Function and Circuit of MICOM	19
11- Refrigerator Exploded View and Service Parts List	39

SAFETY PRECAUTIONS

Please read the following instructions before servicing your refrigerator.

1. Check the refrigerator for current leakage.
2. To prevent electric shock, unplug before servicing.
3. Always check line voltage and amperage.
4. Use standard electrical components.
5. Don't touch metal products in the freezer with wet hands. This may cause frostbite.
6. Prevent water from spilling onto electrical elements or the machine parts.
7. Before tilting the refrigerator, remove all materials from on or in the refrigerator .
8. When servicing the evaporator, wear gloves to prevent injuries from the sharp evaporator fins.
9. Service on the refrigerator should be performed by a qualified technician. Sealed system repair must be performed by a CFC certified technician.

1. SPECIFICATIONS

LBC22518WW	
ITEMS	SPECIFICATIONS
CAPACITY	22 cu.ft
RATING	115 / 60
TEMPERATURE CONTROL	F - CONTROL
SHELF, R	FIX (4)
SHELF, F	WIRE
TRAY DRAWER -F/L	YES (WIRE)
TRAY DRAWER -F/U	NO
HANDLE	PL-SMOOTH / (WIRE)
LAMP, F	YES (1) / 60W
LAMP, R	YES (2) / 60W
REVERSIBLE DOOR	YES
ICE TRAY & BANK	NO
BASKET COLOR	OPAQUE + TRANSPARENT
BASKET, F	
BASKET R	2 1/3 + 2 2/3 + FULL(1)
TRAY VEGETABLE	NORMAL

LBC22518ST	
ITEMS	SPECIFICATIONS
CAPACITY	22 cu.ft
RATING	115 / 60
TEMPERATURE CONTROL	F - CONTROL
SHELF, R	FIX (4)
SHELF, F	WIRE
TRAY DRAWER -F/L	YES (WIRE)
TRAY DRAWER -F/U	NO
HANDLE	CURVED
LAMP, F	YES (1) / 60W
LAMP, R	YES (2) / 60W
REVERSIBLE DOOR	YES
ICE TRAY & BANK	NO
BASKET COLOR	OPAQUE + TRANSPARENT
BASKET, F	PLASTIC (1)
BASKET R	2 1/3 + 2 2/3 + FULL(1)
TRAY VEGETABLE	NORMAL

2. PARTS IDENTIFICATIONS

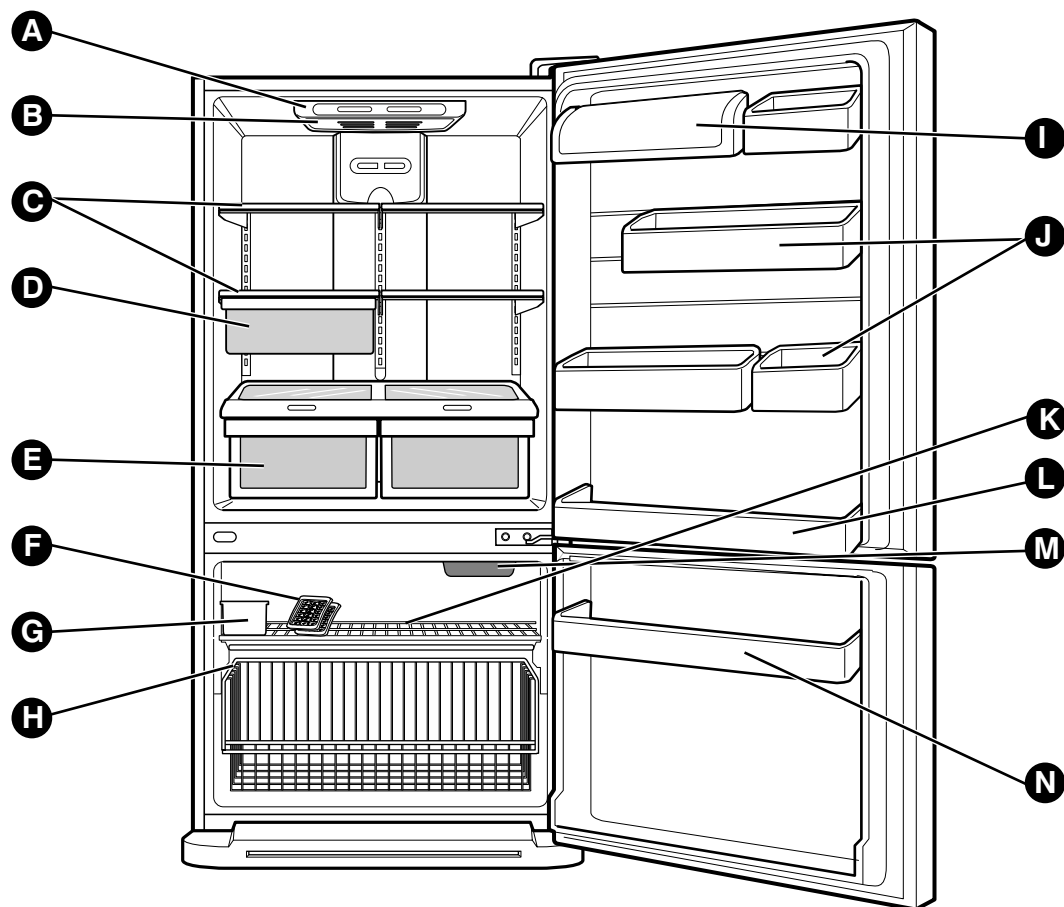

Use this section to become more familiar with the parts and features.

NOTE: This guide covers several different models. The refrigerator you have purchased may have some or all of the items listed below. The locations of the features shown below may not match your model.

- | | |
|---|--|
| <ul style="list-style-type: none"> Ⓐ Digital Sensor Control Ⓑ Refrigerator Light Ⓒ Shelves Ⓓ Snack Pan Ⓔ Optibin Crisper
Keeps fruits and vegetable fresh and crisp Ⓕ Ice Tray* Ⓖ Ice Bin Ⓗ Wire Durabase | <ul style="list-style-type: none"> Ⓘ Dairy Bin Ⓝ Design-A-Door Ⓚ Wire Freezer Shelf Ⓛ Refrigerator Door Rack Ⓜ Freezer Light Ⓝ Freezer Door Rack |
|---|--|

*on some models

3. DISASSEMBLY

3-1 DOOR

Refrigerator Door

1. Remove the hinge cover by pulling it upwards.
2. Loosen the hexagonal bolts attaching the upper hinge to the body and lift the freezer door.

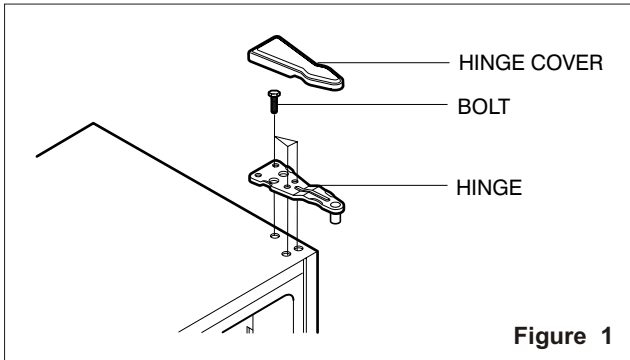

3. Pull out the door gasket to remove from the door foam assembly.

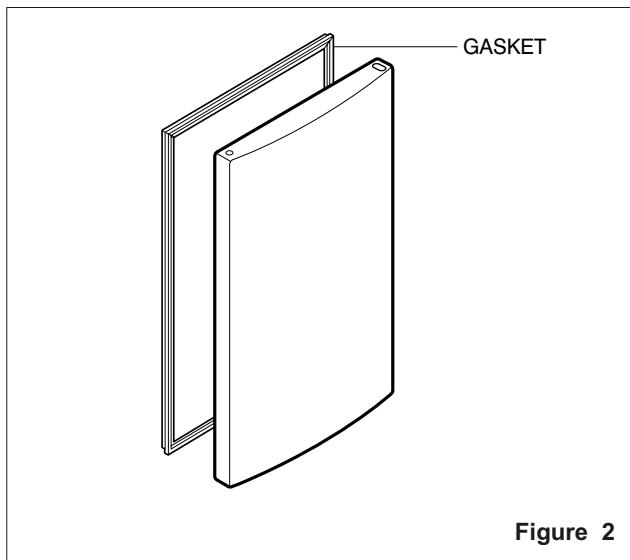

Freezer Door

1. Loosen the hexagonal bolts attaching the lower hinge to the body to remove the refrigerator door only.

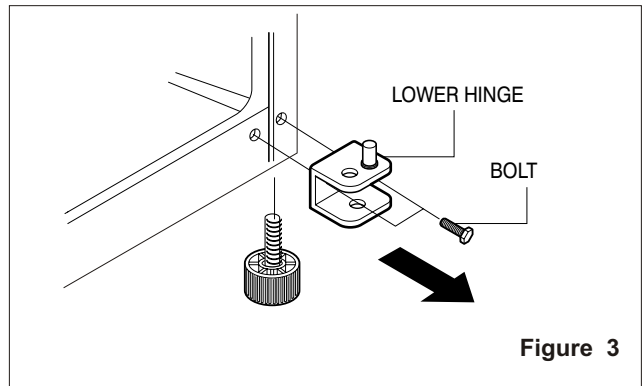

2. Pull out the door gasket to remove from the door foam assembly.

3-2 DOOR SWITCH

1. To remove the door switch, pry it out with a slotted-type driver, as shown in (Figure 4).
2. Disconnect the lead wire from the switch.

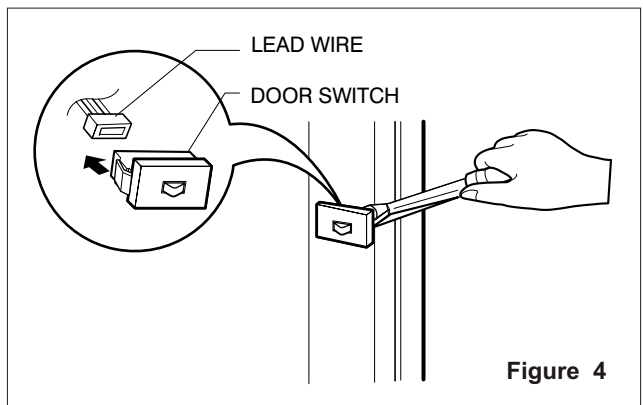

3-3 FAN AND FAN MOTOR

1. Remove the freezer shelf. (If your refrigerator has an icemaker, remove the icemaker first)
2. Remove the grille by pulling it out and by loosening a screw.
3. Remove the Fan Motor assembly by loosening 2 screws and disassemble the shroud.
4. Pull out the fan and separate the Fan Motor and Bracket.
5. Pull out the fan and separate the Fan Motor and Bracket.

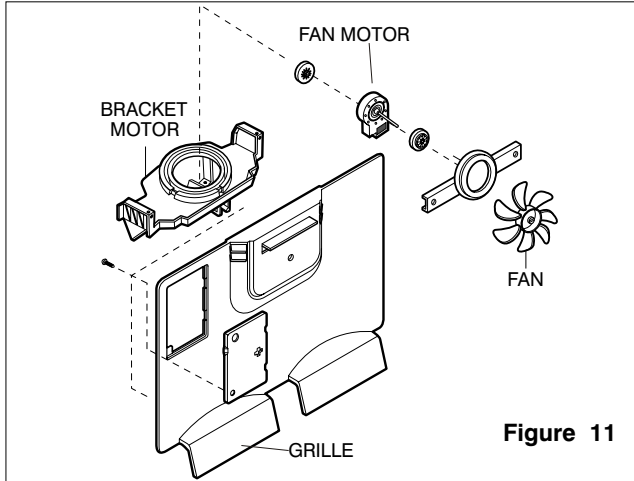

Figure 11

3-4 DEFROST CONTROL ASSEMBLY

Defrost Control assembly consists of Defrost Sensor and FUSE-M.

The Defrost Sensor works to defrost automatically. It is attached to the metal side of the Evaporator and senses its Temperature.

Fuse-M is a safety device for preventing over-heating of the Heater when defrosting.

At 72°C, it turns the Defrost Heater off.

1. Pull out the grille assembly. (Figure 6)
2. Separate the connector with the Defrost Control assembly and replace the Defrost Control assembly after cutting the Tie Wrap. (Figure 7)

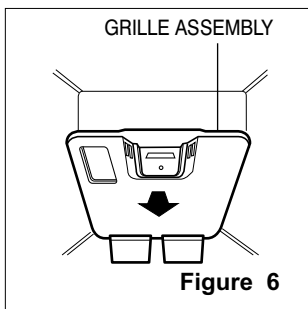

Figure 6

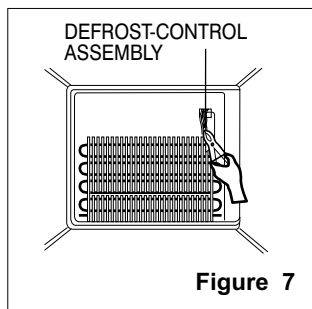

Figure 7

3-5 LAMP

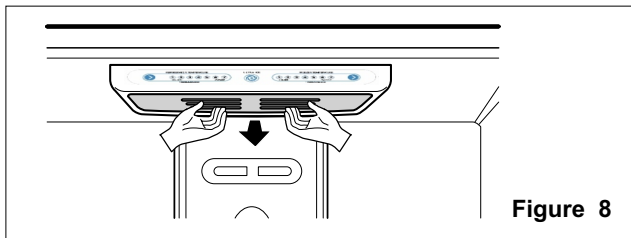

Figure 8

3-5-1 Refrigerator Compartment Lamp

1. Unplug the power cord from the outlet.
2. Remove refrigerator shelves.
3. Release the hooks on both ends of the lamp shield and pull the shield downward to remove it.
4. Turn the lamp counterclockwise.
5. Assemble in reverse order of disassembly. Replacement bulb must be the same specification as the original (Max. 60 W-2EA).

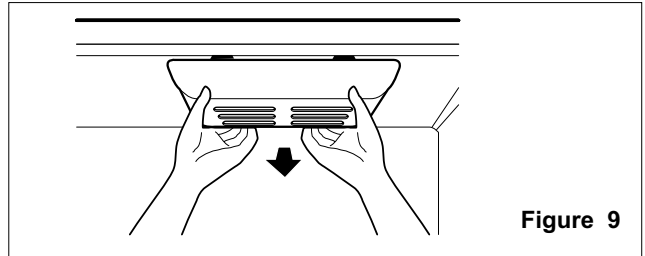

Figure 9

3-5-2 Freezer Compartment Lamp

1. Unplug refrigerator or disconnect power.
2. Reach behind light shield to remove bulb.
3. Replace bulb with a 60-watt appliance bulb.
4. Plug in refrigerator or reconnect power.

3-6 CONTROL BOX-REFRIGERATOR

1. First, remove all shelves in the refrigerator, then remove the Refrigerator control Box by loosening 2 screws.

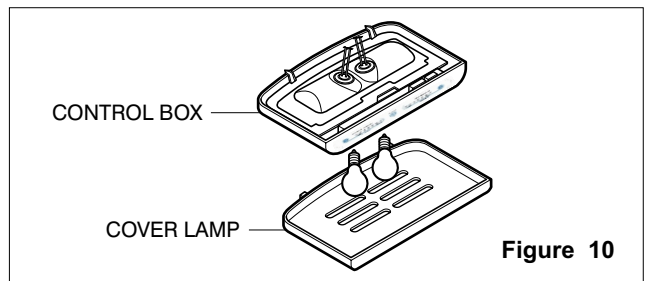

Figure 10

2. Remove the Refrigerator Control Box by pulling it downward.
3. Disconnect the lead wire on the right position and separate the lamp sockets.

3-7 MULTI DUCT

1. Remove an upper and lower Cap by using a flat screwdriver, and loosen 3 screws. (Figure 11)
2. Disconnect the lead wire on the bottom position.

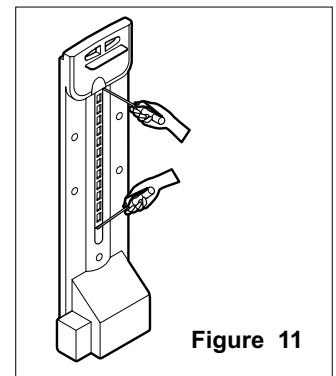

Figure 11

4. ADJUSTMENT

4-1 COMPRESSOR

4-1-1 Role

The compressor intakes low temperature and low pressure gas from the evaporator of the refrigerator and compresses this gas to high-temperature and high-pressure gas. It then delivers the gas to the condenser.

4-1-2 Composition

The compressor includes overload protection. The PTC starter and OLP (overload protector) are attached to the outside of the compressor. Since the compressor is manufactured to tolerances of 1 micron and is hermetically sealed in a dust and moisture-free environment, use extreme caution when repairing it.

4-1-3 Note for Usage

- (1) Be careful not to allow over-voltage and over-current.
- (2) If compressor is dropped or handled carelessly, poor operation and noise may result.
- (3) Use proper electric components appropriate to the Particular Compressor in your product.
- (4) Keep Compressor dry.
If the Compressor gets wet (in the rain or a damp environment) and rust forms in the pin of the Hermetic Terminal, poor operation and contact may result.
- (5) When replacing the Compressor, be careful that dust, humidity, and soldering flux dirt contaminate the inside of the compressor. Dust, humidity, and solder flux contaminate the cylinder and may cause noise, improper operation or even cause it to lock up.

4-2 PTC-STARTER

4-2-1 Composition of PTC-Starter

- (1) PTC (Positive Temperature Coefficient) is a no-contact semiconductor starting device which uses ceramic material consisting of BaTiO₃.
- (2) The higher the temperature is, the higher the resistance value. These features are used as a starting device for the Motor.

4-2-2 Role of PTC-Starter

- (1) The PTC is attached to the Sealed Compressor and is used for starting the Motor.
- (2) The compressor is a single-phase induction motor. During the starting operation, the PTC allows current flow to both the start winding and main winding.

4-2-3 PTC-Applied Circuit Diagram Starting Method for the Motor

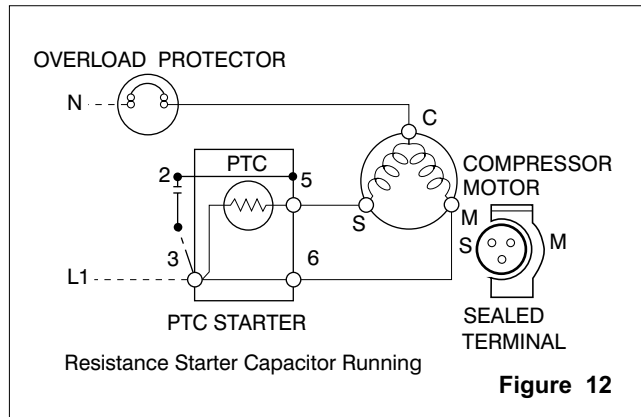

4-2-4 Motor Restarting and PTC Cooling

- (1) It requires approximately 5 minutes for the pressure to equalize before the compressor can restart.
- (2) The PTC device generates heat during operation. Therefore, it must be allowed to cool before the compressor can restart.

4-2-5 Relation of PTC-Starter and OLP

- (1) If the compressor attempts to restart before the PTC device is cooled, the PTC device will allow current to flow only to the main winding.
- (2) The OLP will open because of the over current condition. This same process will continue (3 to 5 times) when the compressor attempts to restart until the PTC device has cooled. The correct OLP must be properly attached to prevent damage to the compressor.
Parts may appear physically identical but could have different electrical ratings. Replace parts by part number and model number. Using an incorrect part could result in damage to the product, fire, injury, or possibly death.

4-2-6 Note for Using the PTC-Starter

- (1) Be careful not to allow over-voltage and over-current.
- (2) Do not drop or handle carelessly.
- (3) Keep away from any liquid.
If liquid such as oil or water enters the PTC, PTC materials may fail due to breakdown of their insulating capabilities.
- (4) If the exterior of the PTC is damaged, the resistance value may be altered. This can cause damage to the compressor and result in a no-start or hard-to-start condition.
- (5) Always use the PTC designed for the compressor and make sure it is properly attached to the compressor. Parts may appear physically identical but could have different electrical ratings. Replace parts by part number and model number. Using an incorrect part could result in damage to the product, fire, injury, or possibly death.

4-3 OLP (OVERLOAD PROTECTOR)

4-3-1 Definition of OLP

- (1) OLP (OVERLOAD PROTECTOR) is attached to the Compressor and protects the Motor by opening the circuit to the Motor if the temperature rises and activating the bimetal spring in the OLP.
- (2) When high current flows to the Compressor motor, the Bimetal works by heating the heater inside the OLP, and the OLP protects the Motor by cutting off the current flowing to the Compressor Motor.

4-3-2 Role of the OLP

- (1) The OLP is attached to the Sealed Compressor used for the Refrigerator. It prevents the Motor Coil from being started in the Compressor.
- (2) For normal operation of the OLP, do not turn the Adjust Screw of the OLP in any way.

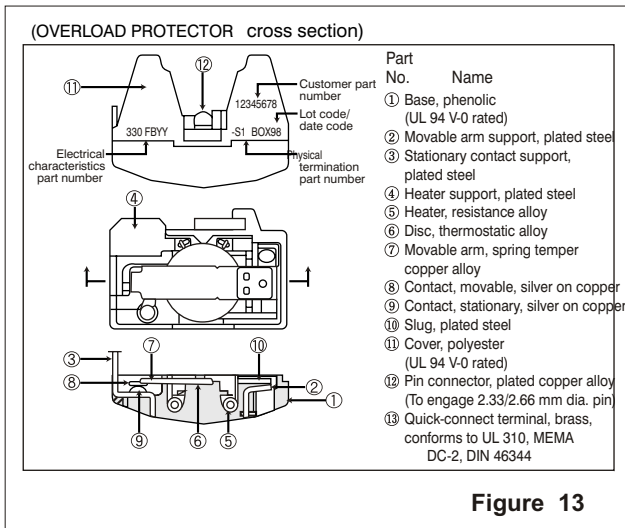
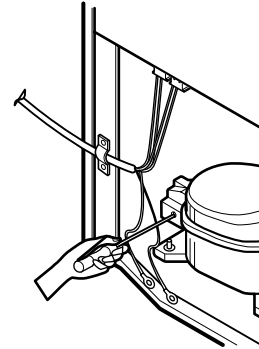
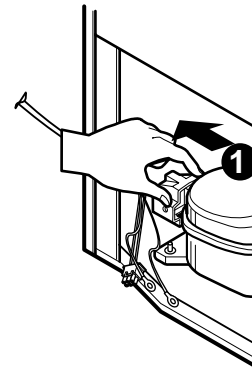

Figure 13

4-4 TO REMOVE THE COVER PTC



- 1) Remove the Cover Back M/C.
- (2) Remove the screw on Cover PTC.



- (3) Remove two Housings on upper part of Cover PTC.
- (4) Take out the cover PTC from upper to lower position like (1).

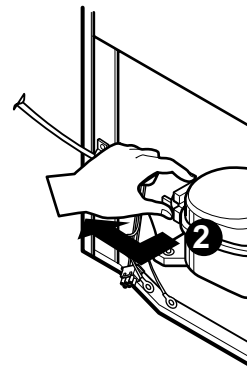

- (5) Turn 45 i in the direction of (2) and take it out.
- (6) Assembly in reverse order of disassembly.

5. CIRCUIT DIAGRAM



LG Electronics CIRCUIT DIAGRAM

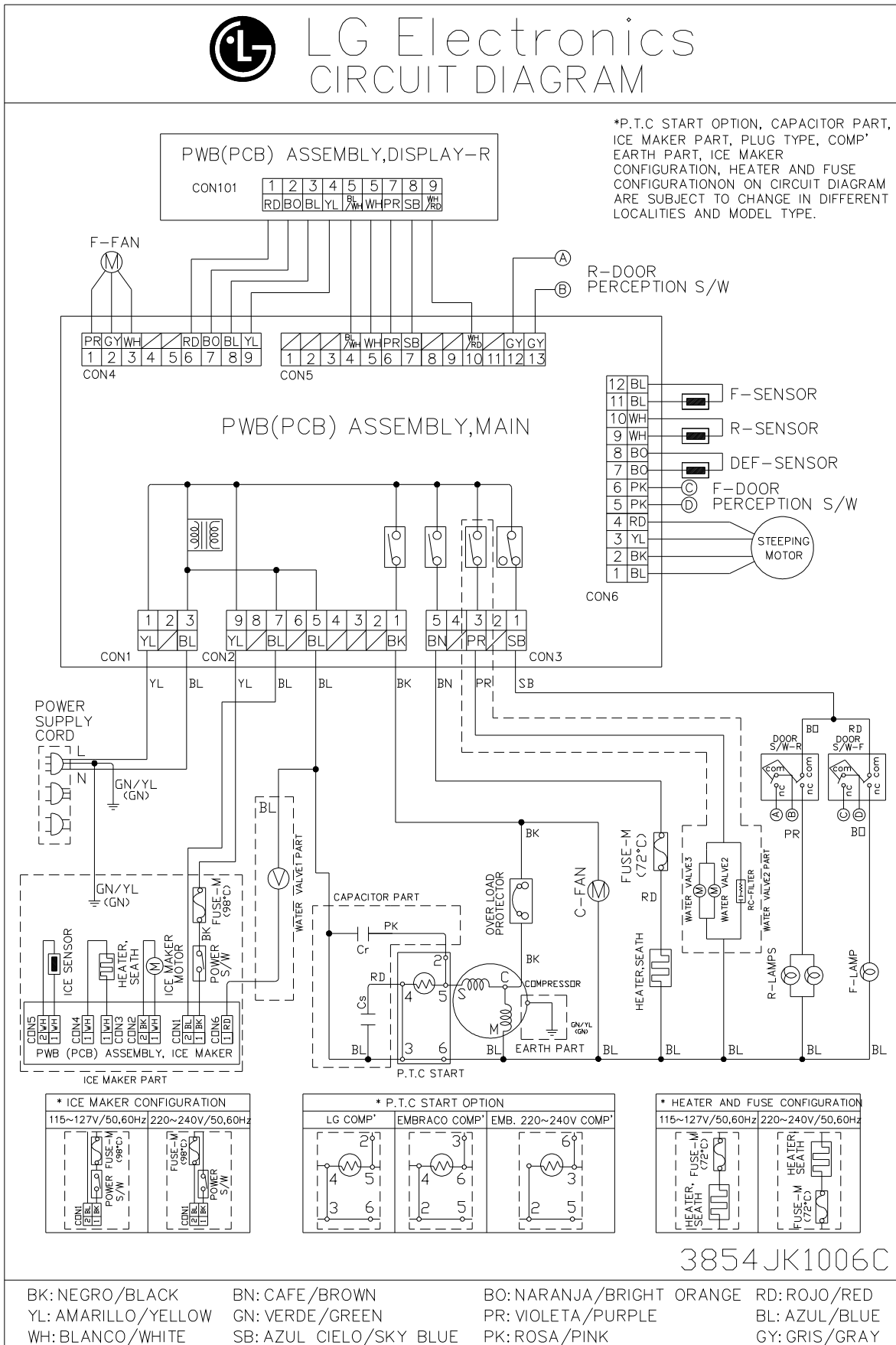

6. TROUBLESHOOTING

6-1 COMPRESSOR AND ELECTRIC COMPONENTS

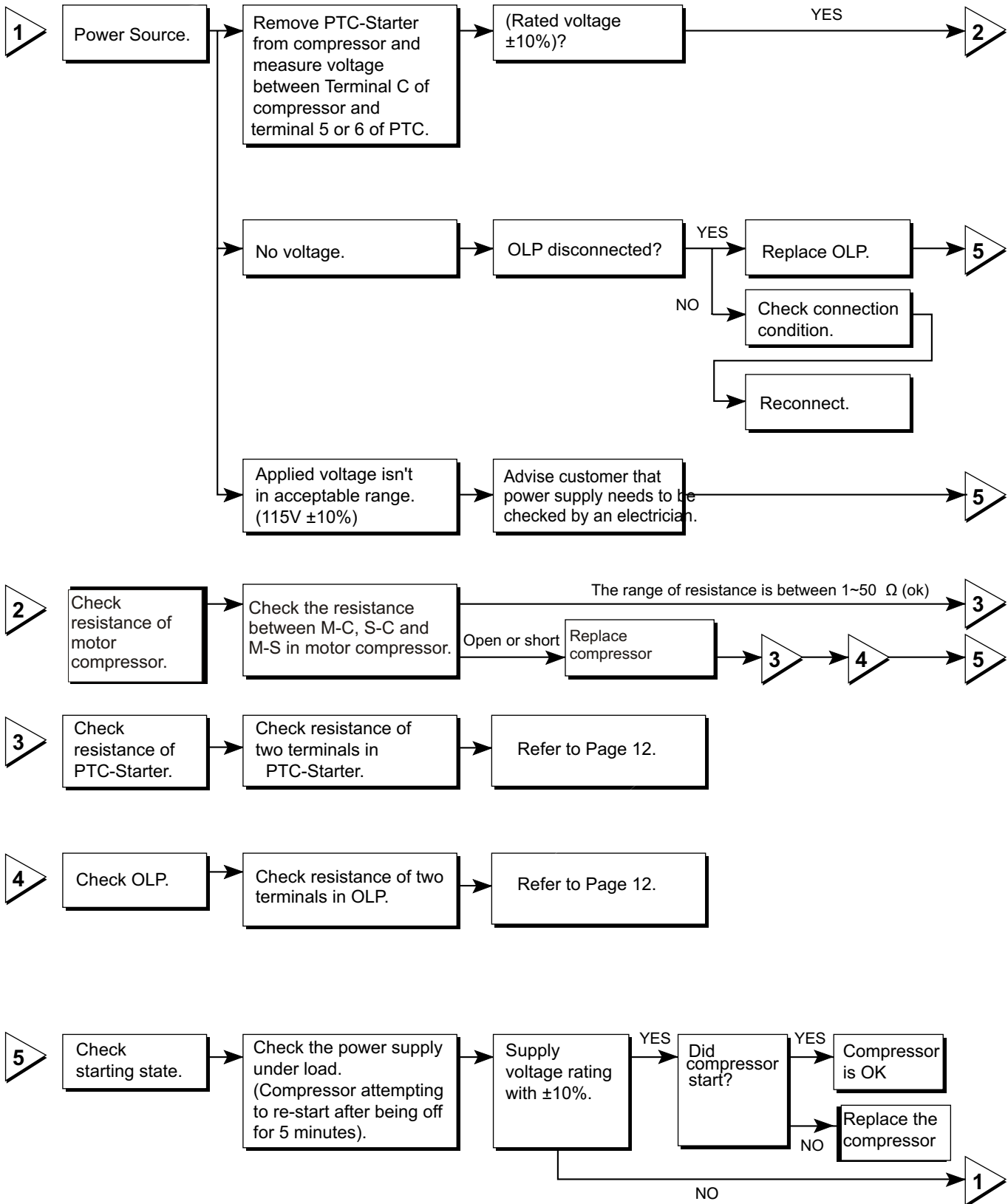

6-2 PTC AND OLP

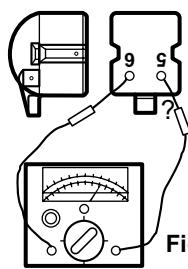
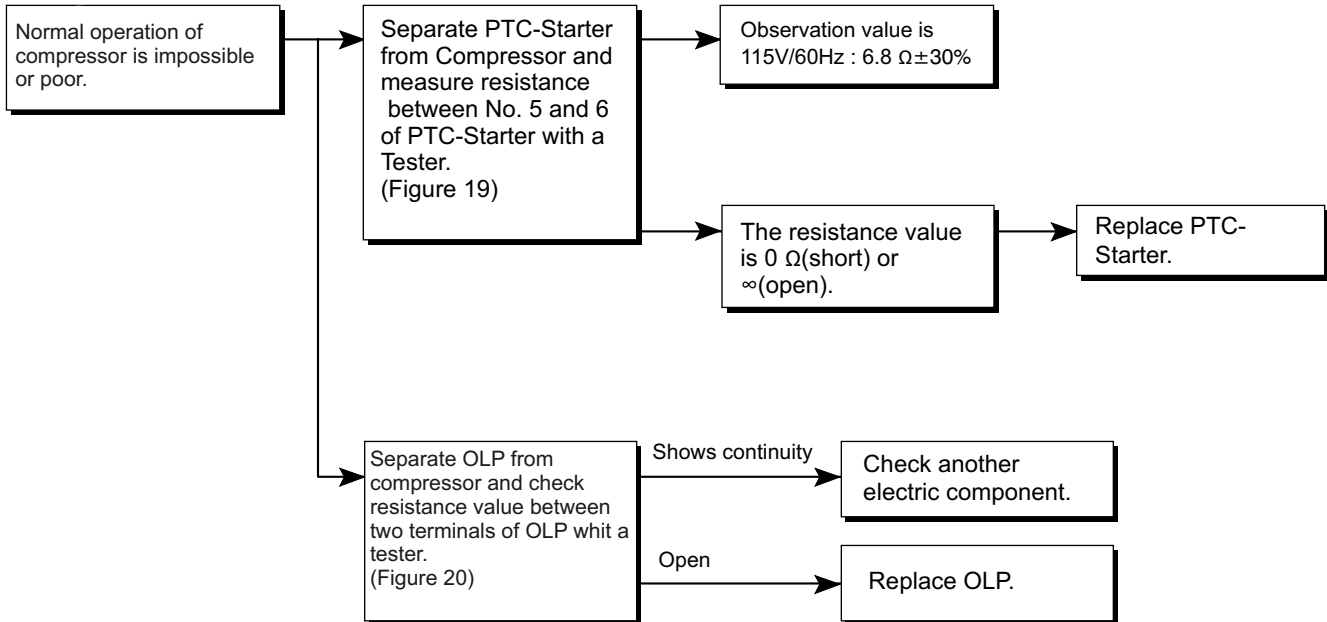

Figure 19

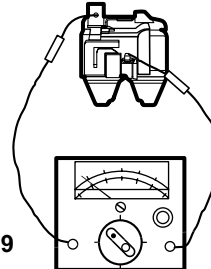
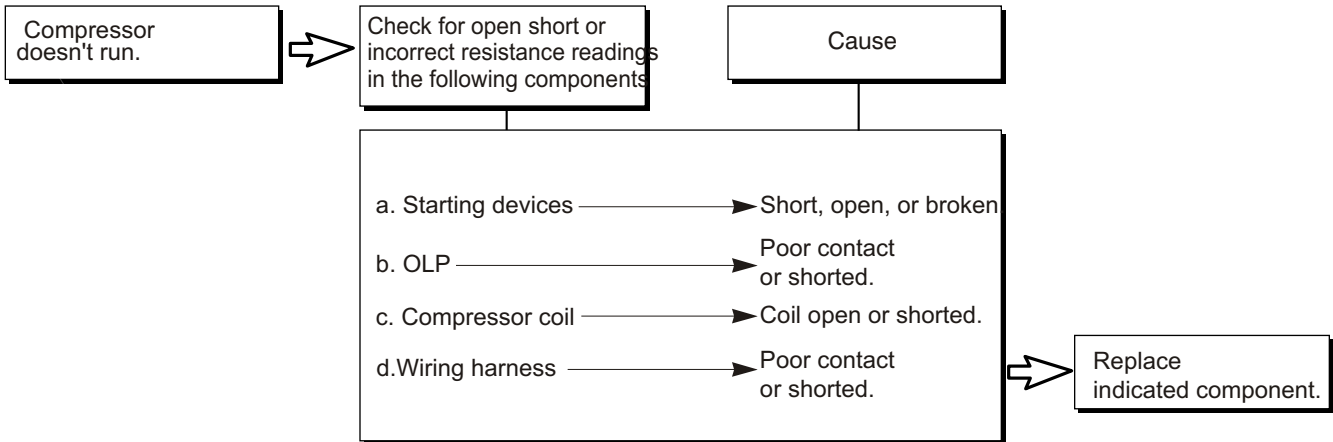

Figure 20

6-3 OTHER ELECTRICAL COMPONENTS

Not cooling at all



Poor cooling performance

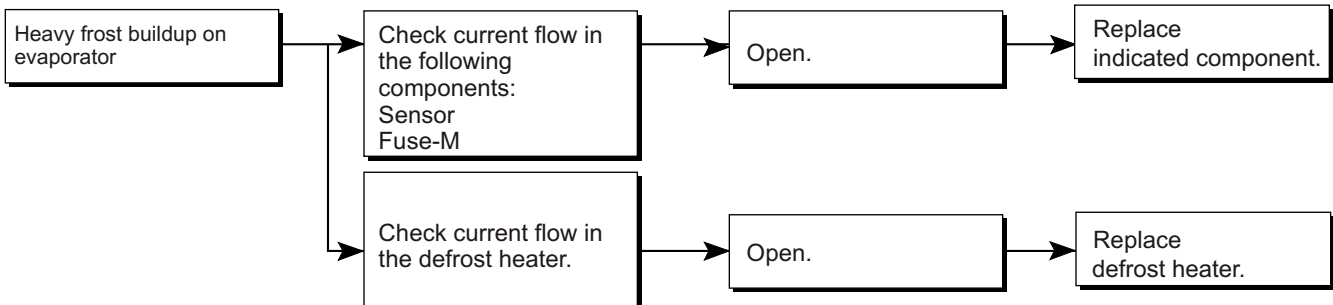
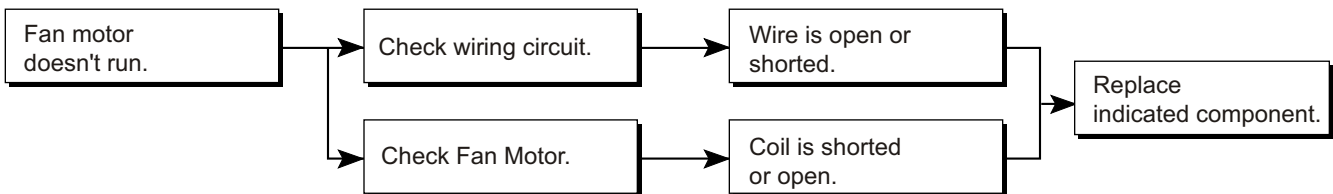
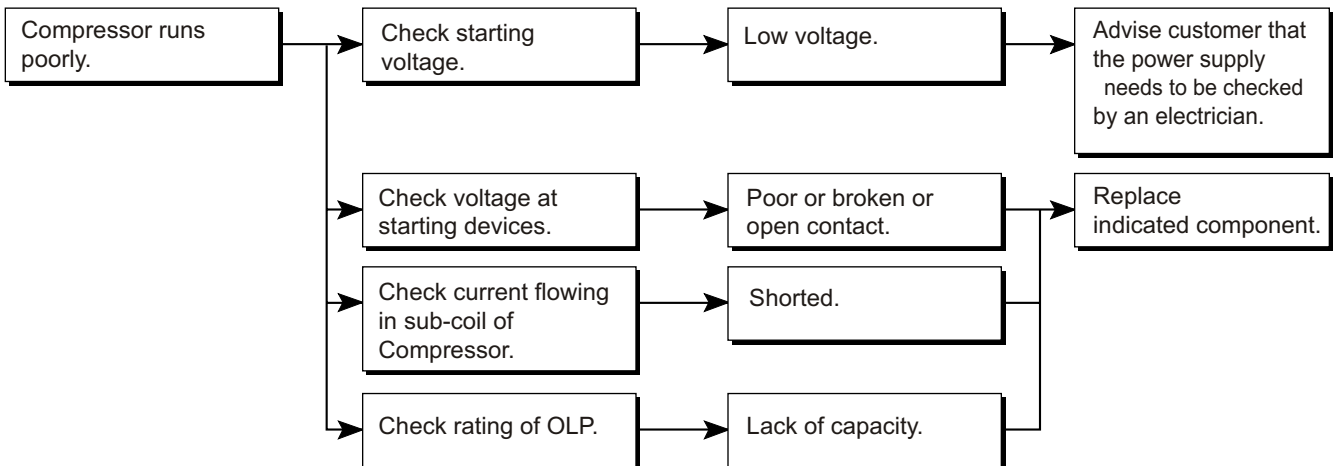

6-4 SERVICE DIAGNOSIS CHART

COMPLAINT	POINTS TO BE CHECKED	REMEDY
No Cooling.	<ul style="list-style-type: none"> • Is the power cord unplugged from the outlet? • Check if the power switch is set to OFF. • Check if the fuse of the power switch is shorted. • Measure the voltage of the power outlet. 	<ul style="list-style-type: none"> • Plug into the outlet. • Set the switch to ON. • Replace the fuse. • If the voltage is low, correct the wiring.
Cools poorly.	<ul style="list-style-type: none"> • Check if the unit is placed too close to the wall. • Check if the unit is placed too close to the stove, gas cooker, or in direct sunlight. • Is the ambient temperature too high or the room door closed? • Check if food put in the refrigerator is hot. • Did you open the door of the unit too often or check if the door is sealed properly? • Check if the Control is set to Warm position. 	<ul style="list-style-type: none"> • Place the unit about 4 inches (10 cm) from the wall. • Place the unit away from these heat sources. • Lower the ambient temperature. • Put in foods after they have cooled down. • Don't open the door too often and close it firmly. • Set the control to Recommended position.
Foods in the Refrigerator are frozen.	<ul style="list-style-type: none"> • Is food placed in the cooling air outlet? • Check if the control is set to colder position. • Is the ambient temperature below 41°F(5°C)? 	<ul style="list-style-type: none"> • Place foods in the high-temperature section. (front part) • Set the control to Recommended position. • Set the control to Warm position.
Condensation or ice forms inside the unit.	<ul style="list-style-type: none"> • Is liquid food sealed? • Check if food put in the refrigerator is hot. • Did you open the door of the unit too often or check if the door is sealed properly? 	<ul style="list-style-type: none"> • Seal liquid foods with wrap. • Put in foods after they have cooled down. • Don't open the door too often and close it firmly.
Condensation forms in the Exterior Case.	<ul style="list-style-type: none"> • Check if the ambient temperature and humidity of the surrounding air are high. • Is there a gap in the door gasket? 	<ul style="list-style-type: none"> • Wipe moisture with a dry cloth. It will disappear in low temperature and humidity. • Fill up the gap.
There is abnormal noise.	<ul style="list-style-type: none"> • Is the unit positioned in a firm and even place? • Are any unnecessary objects placed in the back side of the unit? • Check if the Tray Drip is not firmly fixed. • Check if the cover of the compressor enclosure in the front lower side is taken out. 	<ul style="list-style-type: none"> • Adjust the Leveling Screw, and position the refrigerator in a firm place. • Remove the objects. • Fix the Tray Drip firmly in the original position. • Place the cover in its original position.
Door does not close well.	<ul style="list-style-type: none"> • Check if the door gasket is dirty with an item like juice. • Is the refrigerator level? • Is there too much food in the refrigerator? 	<ul style="list-style-type: none"> • Clean the door gasket. • Position in the firm place and level the Leveling Screw. • Make sure food stored in shelves does not prevent the door from closing.
Ice and foods smell unpleasant.	<ul style="list-style-type: none"> • Check if the inside of the unit is dirty. • Are foods with a strong odor unwrapped? • The unit smells of plastic. 	<ul style="list-style-type: none"> • Clean the inside of the unit. • Wrap foods that have a strong odor. • New products smell of plastic, but this will go away after 1-2 weeks.

Other possible problems:

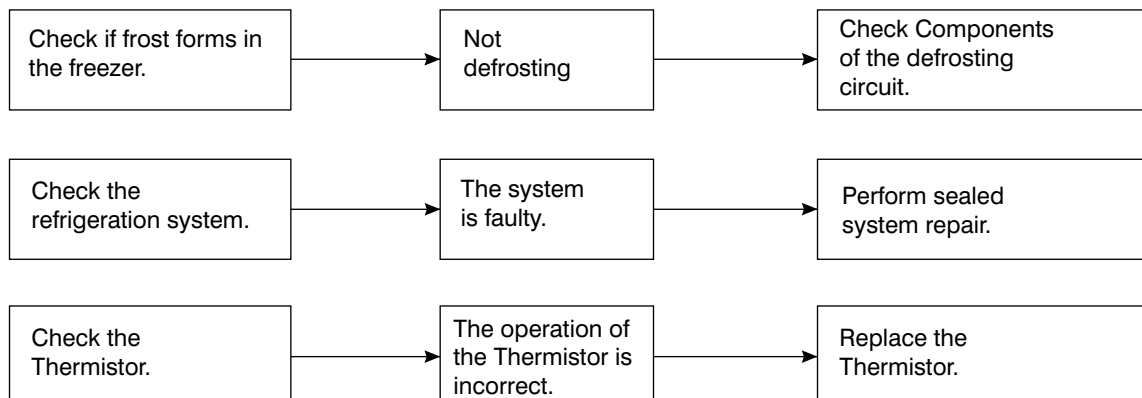

6-5 REFRIGERATION CYCLE

* Troubleshooting Chart

CAUSE		STATE OF THE UNIT	STATE OF THE EVAPORATOR	TEMPERATURE OF THE COMPRESSOR	REMARKS
LEAKAGE	PARTIAL LEAKAGE	Freezer compartment and refrigerator don't cool normally	Low flowing sound of refrigerant is heard and frost forms in inlet only.	A little higher than ambient temperature.	- Refrigerant level is low due to a leak. - Normal cooling is possible by restoring the normal amount of refrigerant and repairing the leak.
	COMPLETE LEAKAGE	Freezer compartment and refrigerator don't cool normally	Flowing sound of refrigerant is not heard and frost isn't formed.	Equal to ambient temperature.	- No discharging of refrigerant. - Normal cooling is possible by restoring the normal amount of refrigerant and repairing the leak.
CLOGGED BY DUST	PARTIAL CLOG	Freezer compartment and refrigerator don't cool normally	Flowing sound of refrigerant is heard and frost forms in inlet only.	A little higher than ambient temperature.	- Normal discharging of the refrigerant. - The capillary tube is faulty.
	WHOLE CLOG	Freezer compartment and refrigerator don't cool.	Flowing sound of refrigerant is not heard and frost isn't formed.	Equal to ambient temperature.	- Normal discharging of the refrigerant.
MOISTURE CLOG		Cooling operation stops periodically.	Flowing sound of refrigerant is not heard and frost melts.	Lower than ambient temperature.	- Cooling operation restarts when heating the inlet of the capillary tube.
DEFECTIVE COMPRESSION	COMPRESSION	Freezer and refrigerator don't cool.	Low flowing sound of refrigerant is heard and frost forms in inlet only.	A little higher than ambient temperature.	- Low pressure at high side of compressor due to low refrigerant level.
	NO COMPRESSION	No compressing operation.	Flowing sound of refrigerant is not heard and there is no frost.	Equal to ambient temperature	- No pressure in the high pressure part of the compressor.

6-5-1 SEALED SYSTEM DIAGNOSIS

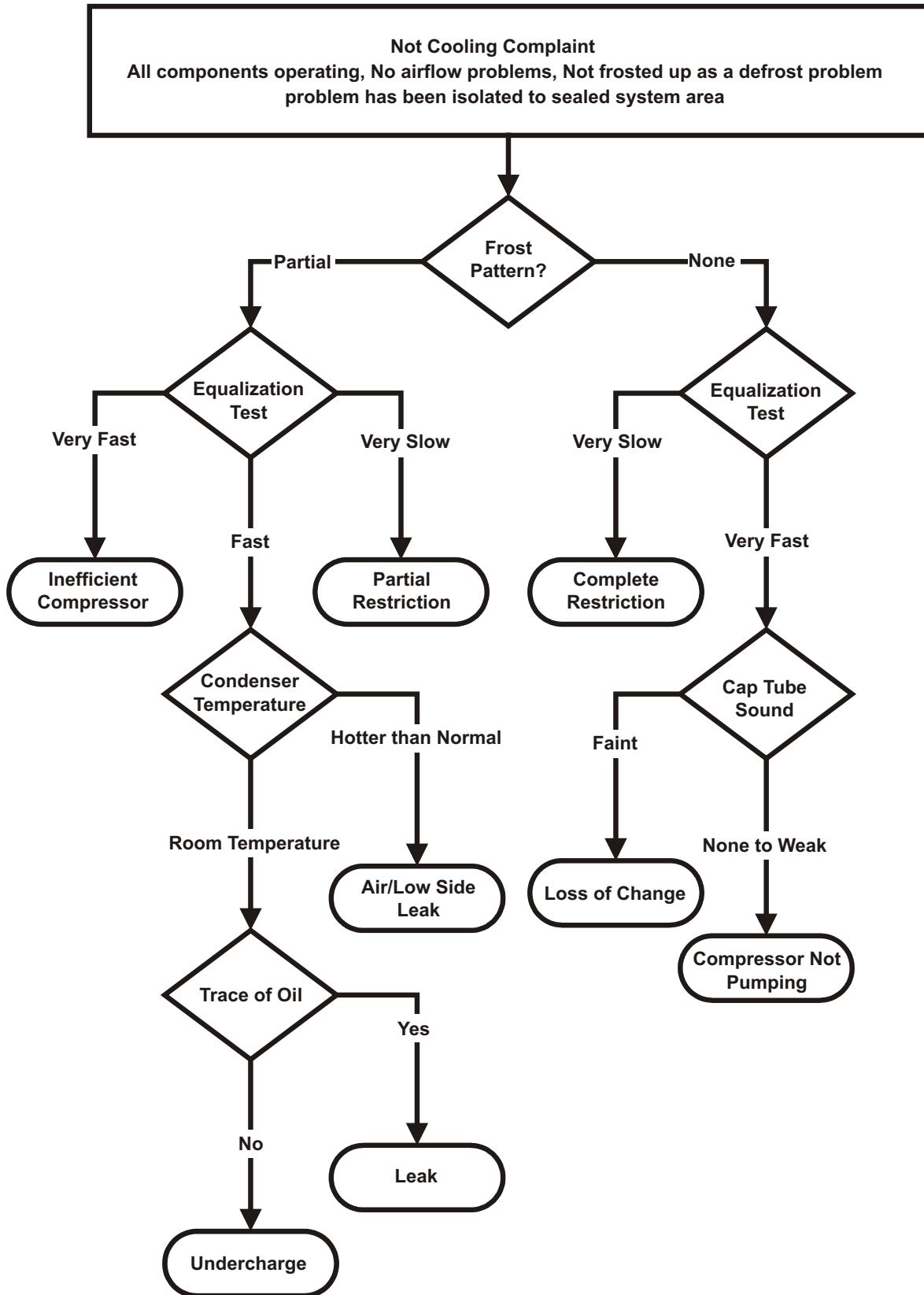

(The equalization test is trying to restart a compressor after it has been operating.)

7. OPERATION PRINCIPLE AND REPAIR METHOD OF ICE MAKER

7-1 OPERATION PRINCIPLE

7-1-1 Operation Principle of Ice Maker

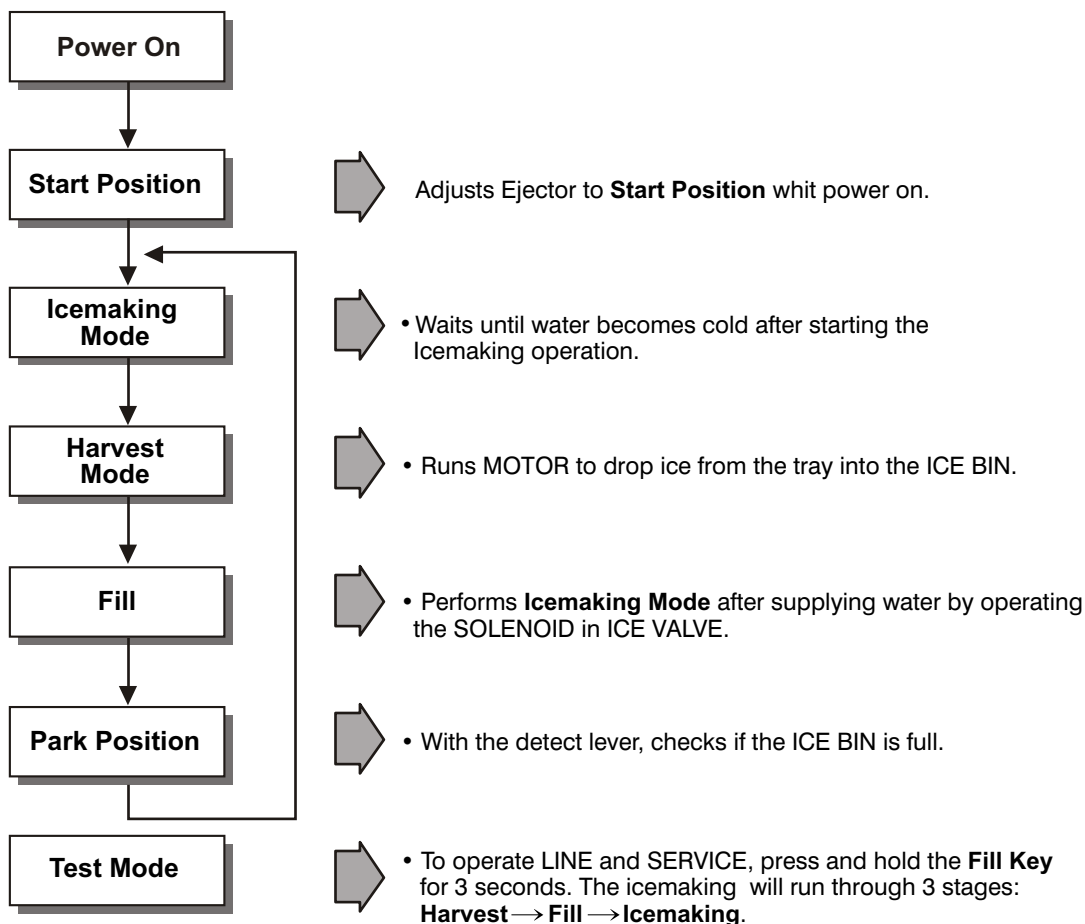

1. Turning the Icemaker stop switch off (O) stops the icemaking function.
2. Setting the Icemaker switch to OFF and then turning it back on will reset the icemaker control.

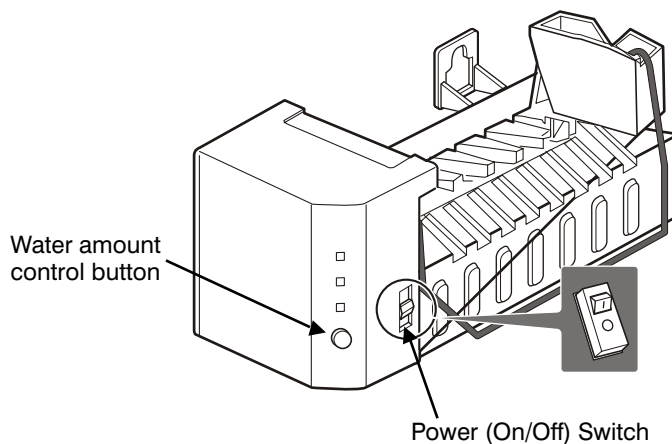

7-2 ICE MAKER FUNCTIONS

7-2-1 Ice Making Mode

1. Icemaking refers to the freezing of supplied water in the ice trays. Complete freezing is assured by measuring the temperature of the Tray with icemaking SENSOR.
2. Icemaking starts after completion of the water fill operation.
3. The icemaking function is completed when the sensor reaches -7°C , 60 to 240 minutes after starting.

NOTE : After icemaker power is ON, the icemaker heater will be on for test for 9 sec.

7-2-2 Harvest Mode



1. Harvest (Ice removing) refers to the operation of dropping ices into the ice bin from the tray when icemaking has completed.
2. Harvest mode:
 - (1) The Heater is ON for 30 seconds, then the motor starts.
 - (2) Harvest mode is completed if it reaches start position again while Heater & Motor are on at the same time.
 - A. ice bin is full : The EJECTOR stops (heater off).
 - B. ice bin is not full : The EJECTOR rotates twice to open for ice.

NOTE : If the EJECTOR does not rotate once within 5 minutes in status (2), separate heater control mode starts operating to prevent the EJECTOR from being constrained. (It is recommended that the user open for ice to return to normal mode.)

7-2-3 Fill/Park Position

1. Once a normal harvest mode has been completed, the water solenoid will be activated.
2. The amount of water is adjusted by pressing the fill key repeatedly. This changes the time allowed for fill as illustrated in the table below.





Water supply amount table

STAGE	TIME TO SUPPLY	INDICATIONS	REMARKS
1	6 sec.		The water amount will vary depending on the water control switch setting, as well as the water pressure of the connected water line.
2	7 sec.		
3	8 sec.		

7-2-4 Function TEST



1. This is a compulsory operation for test, service, cleaning, etc. It is operated by pressing and holding the fill key for 3 seconds.
2. The test works only in the Icemaking Mode. It cannot be entered from the Harvest or Fill mode. (If there is an ERROR, it can only be checked in the TEST mode.)
3. **Caution!** If the test is performed before water in the icemaker is frozen, the ejector will pass through the water. When the fill mode begins (Stage 4), unless the water supply has been shut off, added water will overflow into the ice bin. If the control Doesn't operate normally in the TEST mode, check and repair as needed.
4. After water is supplied, the normal CYCLE is followed: **icemaking** ⇒ **Harvest** ⇒ **Fill** ⇒ **Park Position**.
5. Five seconds after Stage 5 is completed, the icemaker returns to MICOM control. The time needed to supply water resets to the pre- test setting.

Diagnosis TABLE

STAGE	ITEMS	INDICATOR	REMARKS
1	HEATER		Five seconds after heater starts, heater will go off if temperature recorded by sensor is 10°C or lever is in up position.
2	MOTOR		Five seconds after heater starts, you can confirm that motor is moving.
3	HALL IC (TRAY)		You can confirm Hall IC detection of position.
4	SOLENOID VALVE		Two seconds after detection of initial position, you can confirm that valve is on.
5	HALL IC (LEVER)		You can check when the Hall IC is sensing a full ice condition. (If there is a water fill error, the fifth LED is not on.)
6	Reset	Return to Status prior to TEST MODE	Five seconds after fifth stage is completed, the icemaker resets to initial status.

7-3 DEFECT DIAGNOSIS FUNCTION

7-3-1 ERROR CODES shown on Ice Maker water supply control panel

NO	DIVISION	INDICATOR	CONTENTS	REMARKS
1	Normal	Mark time to supply	None	Display switch operates properly
2	Icemaking Sensor malfunction		Open or short-circuited wire	Make sure that the wire on each sensor is connected.
3	Icemaker Kit malfunction		When ejector blades don't reach park position over 18 minutes after harvest mode starts.	Check HALL IC/MOTOR/HEATER/RELAY

*ERROR indicators in table can be checked only in TEST mode.

8. DESCRIPTION OF FUNCTION & CIRCUIT OF MICOM

8-1 FUNCTION

8-1-1 Function

1. When the appliance is plugged in, it is set to "4" for Refrigerator and "4" for freezer.
You can adjust the Refrigerator and the Freezer control temperature by pressing the ADJUST button.
2. When the power is initially applied or restored after a power failure, it is automatically set to "4" & "4".



8-1-2 Control of freezer fan motor

1. Freezer fan motor has high and standard RPMs.
2. High RPM is used when electricity is first on, for ICE PLUS, and when refrigerator is overloaded.
But standard RPM is used for general purposes.
3. To improve cooling speed and load corresponding speed, the RPM of freezer fan motor shall change from normal speed to high speed.
4. High speed (2500RPM) : Initial power on or load corresponding operation, ICE PLUS.
Normal speed (2200 RPM): general working conditions.
5. Fan motor stops when refrigerator or freezer door opens.

8-1-3 ICE PLUS

1. The purpose of this function is to intensify the cooling speed of freezer and to increase the amount of ice.
2. Whenever selection switch is pressed, selection/release, the LED will turn ON or OFF.
3. If there is a power cut and the refrigerator is power on again, ICE PLUS function will be canceled.
4. To activate this function you need to press the ICE PLUS key and the LED will turn ON. This function will remain activated for 24 hrs. The first three hours the compressor and ICE PLUS will be ON. The next 21 hours the freezer will be controlled at the lowest temperature. After 24 hours or if the ICE PLUS key is pressed again, the freezer will return to its previous temperature.
5. For the first three hours notice the following cases:
 - (1) Compressor and freezer fan(HIGH RPM) continuously operate for three hours.
 - (2) If defrost starts during ICE PLUS, ICE PLUS operates for the rest of time after defrost is completed, when ICE PLUS operation time is less than 90 minutes.
If ICE PLUS operates for more than 90 minutes, the ICE PLUS will operate for two hours after defrost is completed.
 - (3) If ICE PLUS is pressed during defrost, ICE PLUS LED is on but this function will start seven minutes after defrost is completed and it shall operate for three hours.
 - (4) If ICE PLUS is selected within seven minutes after compressor has stopped, the compressor (compressor delays seven minutes) shall start after the balance of the delay time.
 - (5) The fan motor in the freezer compartment rotates at high speed during ICE PLUS.
6. For the rest of 21 hours, the freezer will be controlled at the lowest temperature.

8-1-4. REFRIGERATOR LAMP AUTO OFF

1. To protect the risk of lamp heat, when Refrigerator door opens for 7 min., refrigerator lamp is auto off.

8-1-5 Alarm for Open Door

1. This feature sounds a buzzer when the freezer or refrigerator door is not closed within 1 minute after it is opened.
2. One minute after the door is opened, the buzzer sounds three times each for 1/2 seconds. These tones repeat every 30 seconds.
3. The alarm is cancelled when the freezer or the refrigerator is closed while the buzzer sounds.

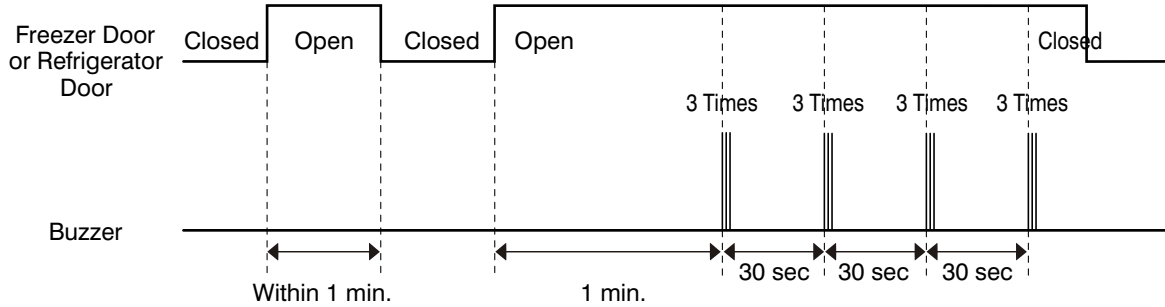

8-1-6 Buzzer Sound

When the button on the front Display is pushed, a Ding~ Dong~ sound is produced.
(Refer to the Buzzer Circuit 8-2-4 No. 3)

8-1-7 Defrosting (removing frost)

1. Defrosting starts each time the COMPRESSOR running time reaches 7 hours.
2. For initial power on or for restoring power, defrosting starts when the compressor running time reaches 4 hours.
3. Defrosting stops if the sensor temperature reaches 46.4°F(8°C) or more. If the sensor doesn't reach 46.4°F(8°C) in 2 hours, the defrost mode is malfunctioning. (Refer to the defect diagnosis function, 8-1-9.)
4. Defrosting won't function if its sensor is defective (wires are cut or short circuited)

8-1-8 Electrical Parts Are Turned On Sequentially

Electrical parts such as COMP, defrosting heater, freezer FAN, etc. are turned on in the following order to prevent noise and parts damage. Several parts are started at the same time at initial power on and are turned off together when TEST is completed.

OPERATING		ORDERS				
Initial power on	Temperature of Defrosting Sensor is 45°C or more (when unit is newly purchased or when moved)	POWER ON	in 1/2 second →	COMP ON	in 1/2 second →	Freezer FAN ON
	Temperature of defrosting sensor is lower than 45°C (when power cuts, SERVICE)	POWER ON	in 1/2 second →	Defrosting heater ON	in 10 second →	Defrosting heater OFF
		in 1/2 second →	COMP ON	in 1/2 second →	Freezer FAN ON	
	Reset to normal operation from TEST MODE	Total load OFF	in 7 minute →	COMP ON	in 1/2 second →	Freezer FAN ON

8-1-9 Defect Diagnosis Function

1. Automatic diagnosis makes servicing the refrigerator easy.
2. When a defect occurs, the buttons will not operate; but the tones. such as ding. will sound.
3. When the defect CODE removes the sign, it returns to normal operation (RESET).
4. The defect CODE shows on the Refrigerator and Freezer Display.



ERROR CODE on display panel

● LED OFF LED ON ○

NO	ITEM		ERROR CODE	CONTENTS	REMARKS
1	Failure of freezer sensor	All off	● ○ ○ ○ ○ ○ ○ ○	Cut or short circuit wire	Inspect Connecting wires on each sensor
2	Failure of Refrigerator sensor	All off	○ ● ○ ○ ○ ○ ○ ○ ○	Cut or short circuit wire	
3	Failure of defrost sensor	All off	○ ○ ● ○ ○ ○ ○ ○ ○	Cut or short circuit wire	
4	Poor of defrost	All off	● ● ● ● ○ ○ ○ ○	2 hours later after starting defrost, If sensor doesn't be over 46°F (8°C)	Snapping of defrost heater or Temperature fuse, pull-out of Connector (indicated minimum 2 Hours after failure occurs)
5	Failure of BLDC fan motor at freezing compartment	All off	● ● ● ● ● ○ ○ ○	If there is no fan motor signal, for more than 65 seg. in operation fan motor.	Poor motor, hocking to wires of fan, contact of structures to fan, snapping or short of lead

8-1-10 TEST Mode

1. The Test mode allows checking the PCB and the function of the product as well as finding out the defective part in case of an error.
2. The test mode is operated by pressing two buttons at Display panel.
3. While in the test mode, the function control button is not recognized, but the recognition tone (beep~) sounds.
4. After exiting the test mode, be sure to reset by unplugging and then plugging in the appliance.
5. If an error, such as a sensor failure, is detected while in the test mode, the test mode is cleared and the error code is displayed.
6. While an error code is displayed, the test mode will not be activated.

MODE	MANIPULATION	CONTENTS	REMARKS
TEST1	Push ULTRA ICE key and ADJUST key of Freezer Temperature at the same time over 3 seconds.	<ol style="list-style-type: none"> 1. Continuous operation of the COMPRESSOR 2. Continuous operation of the freezer fan 3. STEPPING DAMPER OPEN 4. Defrosting Heater OFF 5. Every DISPLAY LED ON 	
TEST2	Push ULTRA ICE key and ADJUST key of Freezer Temperature at the same time over 3 seconds in TEST MODE 1	<ol style="list-style-type: none"> 1. COMP OFF 2. Freezer FAN OFF 3. STEPPING DAMPER CLOSE 4. Defrosting heater ON 5. DISPLAY LED 1, 3, 5, 7 ON 	Reset if the temperature of the Defrosting sensor is 46°F (8°C) or more.
Reset	Push ULTRA ICE key and ADJUST key of Freezer Temp. at the same time over 3 seconds. in TEST MODE 2	Reset to the previously setting before TEST MODE	The compressor will Start after a 7-minute delay.

NOTE : LED CHECK MODE: When the refrigerator temperature control and the freezer temperature control button at the same time are hold for 1 second or longer, every LED on the display turns on at the same time. when the button are released, the previous mode is restored.

* Freezer Fan RPM Variable Check:

In case the freezer fan is in operation when the ADJUST key in Refrigerator and Freezer Temp. Control are pressed for more than one second at the same time freezer fan RPM changes. (for example if high speed, to normal speed or if normal speed, to high speed for 30 seconds)
After 30 seconds, it turns to its original RPM.

* Demonstration MODE:

1. When the ULTRA ICE key and ADJUST key of refrigerator temperature control are pressed for more than 3 seconds at the same time temperature's it converts to demonstration mode.
2. In this status, each LED is rotated with 1 second interval.
3. In this status, all Loads are off (Compressor / Fan / Damper / Heater)
(Even is Demonstration Mode, the refrigerator Lamp automatic off function works normally and can be demonstrated)
4. It reset if you do again as clause.

8-2 PCB FUNCTION

8-2-1 Power Circuit

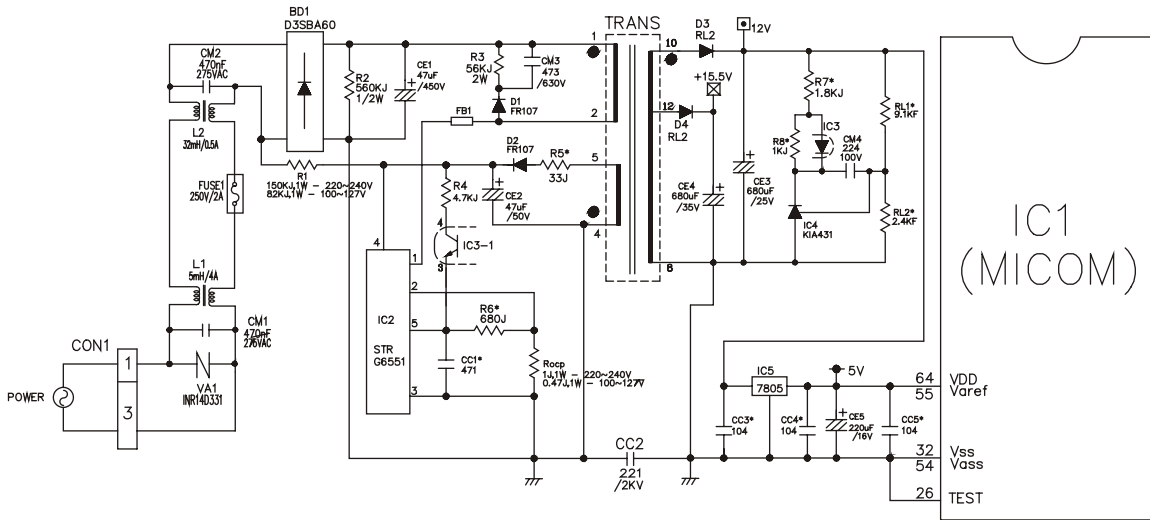

The secondary part of the TRANSFORMER is composed of the power supply for the display, the BLDC FAN Motor drive (15.5 V), the relay drive (12 Vdc) and the MICOM and IC (5 Vdc).

The voltage for each part is as follows:

PART	VA 1	CE 3	CE 4	CE 5
VOLTAGE	115 Vac	12 Vdc	15.5 Vdc	5 V

VA1 is a part for preventing over voltage and noise. When 385V or higher power is applied, the inside elements are short-circuited and broken, resulting in blowout of the fuse in order to protect the elements of the secondary part of the TRANSFORMER.

8-2-2 Oscillation Circuit

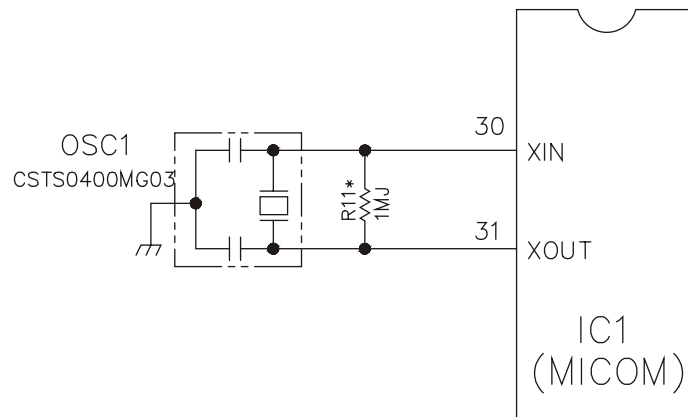

This circuit generates the base clock for calculating time and the synchro clock for transmitting data from and to the inside logic elements of the IC1 (MICOM). Be sure to use specific replacement parts, since calculating time by the IC1 may be changed. If changed, the OSC1 SPEC will not work.

8-2-3 Reset Circuit

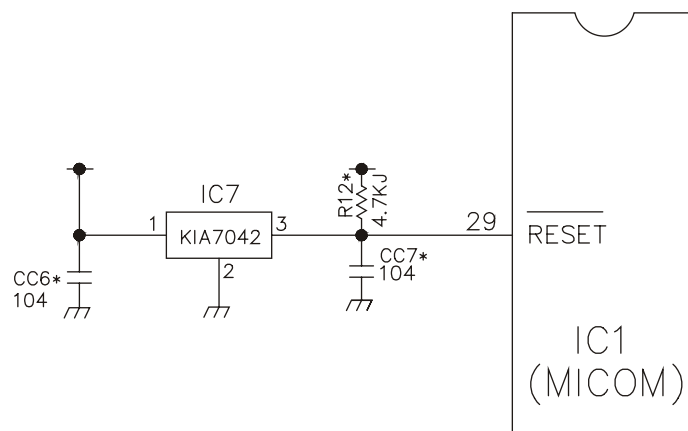

The RESET circuit allows all the functions to start at the initial conditions by initializing various parts, including the RAM inside the MICOM (IC1) when the power is initially supplied or the power supply to the MICOM is restored after a momentary power failure. For the initial 10ms of power supply, LOW voltage is applied to the MICOM RESET terminal. During a normal operation, 5V is applied to the RESET terminal. (If a malfunction occurs in the RESET IC, the MICOM will not operate.)

8-2-4 Load / Buzzer Drive & Open Door Detection Circuit

1. Load Drive Condition Check

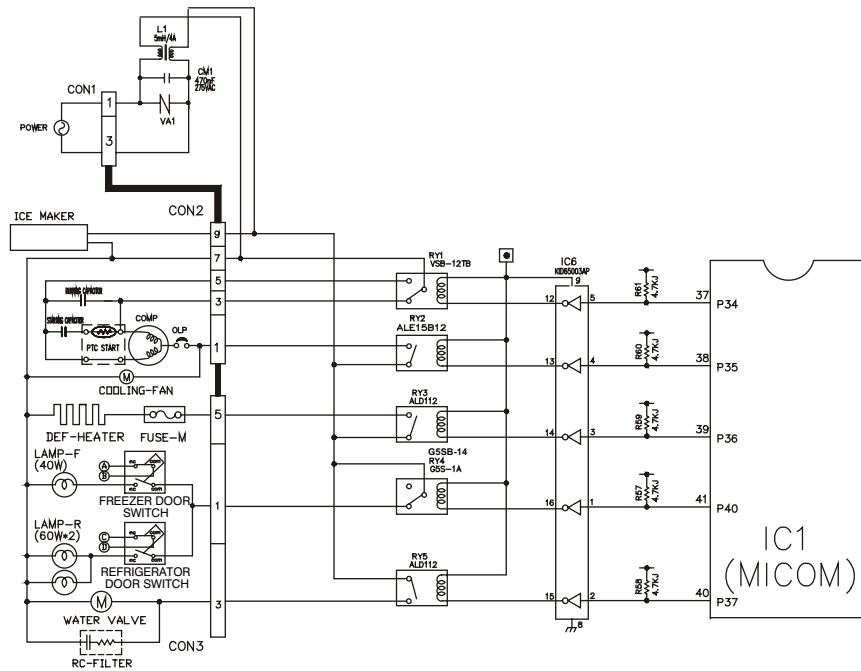

LOAD TYPE		COMP	DEFROSTING HEATER	LAMP	TCM POWER MODE (OPTIONAL)	VALVE (DISPENSER MDL)
Measurement Location (IC6)		NO.13	NO.14	NO.16	NO.12	NO.15
Condition	ON	1V or below				
	OFF	12V				

2. Fan motor driving circuit (freezing compartment fan)

1. This circuit makes standby power 0 by cutting off power supplied to ISs inside of the fan motor in the fan motor OFF.
2. This is a circuit to perform a temporary change of speed for the fan motor and applies DC voltage up to 7.5V ~ 16V to motor.
3. This circuit prevents over-driving the fan motor by cutting off power applied to the fan motor in the lock of fan motor by sensing the operation RPM of the fan motor.

	Ⓐ part	Ⓑ part	Ⓒ part
MOTOR OFF	2V or less	0V	5V
MOTOR ON	13V~15V	0V	2V~3V

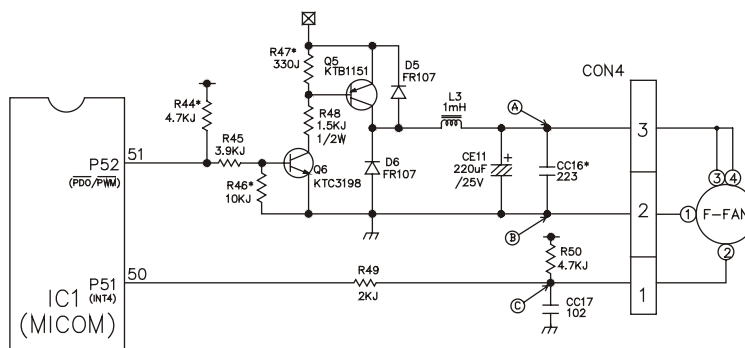

3. Buzzer Drive Condition Check

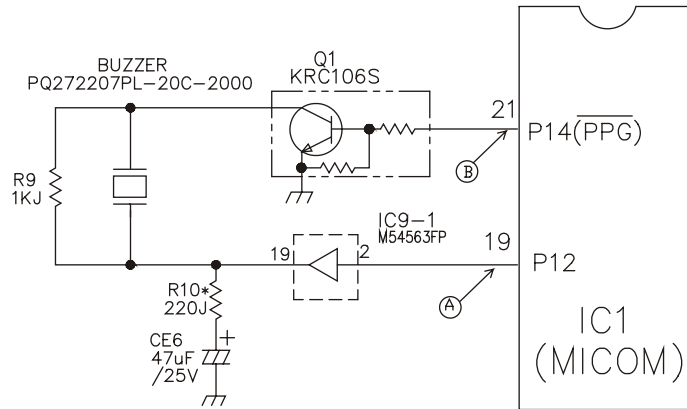

Condition Measurement Location	Tone (Ding~Dong~) when the button on the display is pushed.	Alarm for open door (beep-beep-beep)	OFF
IC1 (A)			0 V
IC1 (B)			0 V

4. Open Door Detection Circuit Check

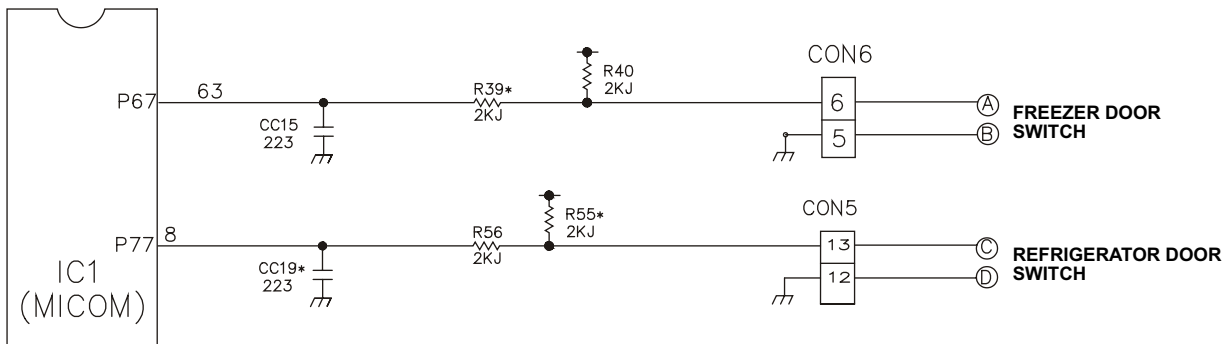

Measurement Location Freezer/ Refrigerator Door	(PIN NO.63 & PIN NO.8)
Closed	5 V
Open	0 V

8-2-5 Temperature Sensor Circuit

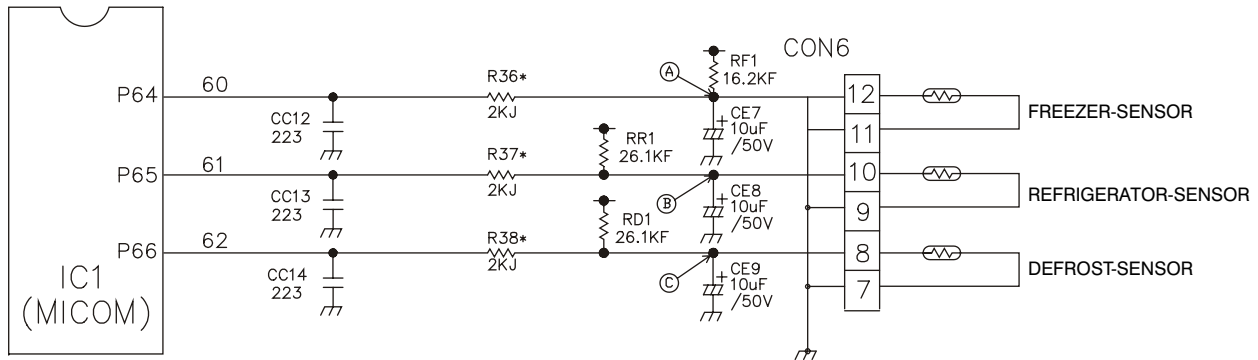

The upper CIRCUIT reads REFRIGERATOR temperature, FREEZER Temperature, and DEFROST-SENSOR temperature for defrosting and the indoor temperature for compensating for the surrounding temperature into MICOM. OPENING or SHORT state of each TEMPERATURE SENSOR are as follows:

SENSOR	CHECK POINT	NORMAL (-30°C ~ 50°C)	SHORT-CIRCUITED	OPEN
Freezer Sensor	POINT Ⓐ Voltage	0.5 V ~ 4.5 V	0 V	5 V
Refrigerator Sensor	POINT Ⓑ Voltage			
Defrosting Sensor	POINT Ⓒ Voltage			

8-2-6 Refrigeration Compartment Stepping Motor Damper Circuit

* The circuit shown below is the damper circuit to regulate the refrigerator temperature.

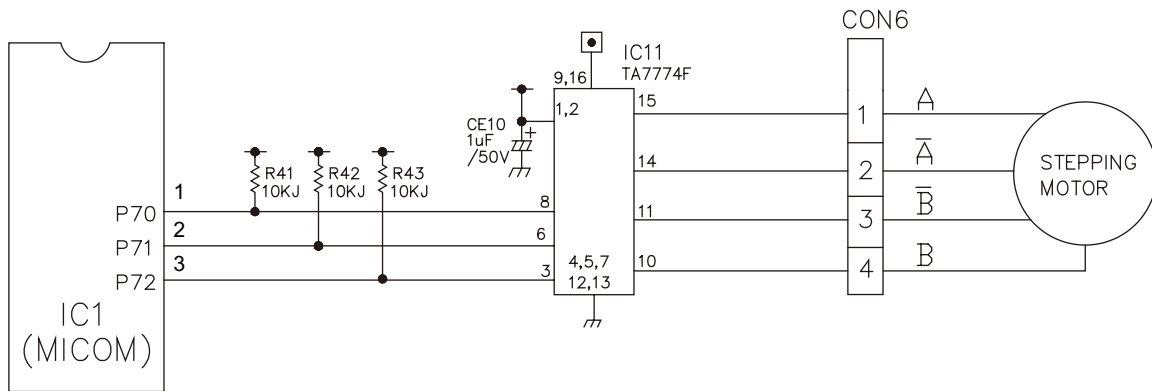

8-2-7 Temperature Compensation & Overcooling/Undercooling Compensation Circuit

1. Refrigerator Temperature Compensation

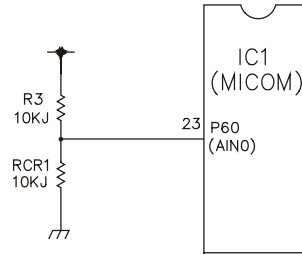

Refrigerator		Remark
Resistance (RCR)	Temperature Compensation	
180 K	+2.5°C	Compensation by raising the temperature ↑
56 K	+2.0°C	
33 K	+1.5°C	
18 K	+1.0°C	
12 K	+0.5°C	
10 K	0°C	Standard Temperature
8.2 K	-0.5°C	Compensation by lowering the temperature ↓
5.6 K	-1.0°C	
3.3 K	-1.5°C	
2 K	-2.0°C	
470	-2.5°C	

Table of Temperature Compensation by adjusting the resistance (difference from the current temperature) e.g., If the refrigerator compensation resistance (RCR) is changed from 10K (the current resistance) to 18K (the adjustment resistance), the temperature of the refrigerator rises 33.8°F(+ 1°C).

2. The temperature compensation for refrigerator compartment is in the following table:

	Revised resistance	470	2k	3.3k	5.6k	8.2k	10k	12k	18k	33k	56k	180k
	Present resistance											
Refrigerator (RCR)	470	No change	0.5°C Up	1°C Up	1.5°C Up	2°C Up	2.5°C Up	3°C Up	3.5°C Up	4°C Up	4.5°C Up	5°C Up
	2k	0.5°C Down	No Change	0.5°C Up	1°C Up	1.5°C Up	2°C Up	2.5°C Up	3°C Up	3.5°C Up	4°C Up	4.5°C Up
	3.3k	1°C Down	0.5°C Down	No Change	0.5°C Up	1°C Up	1.5°C Up	2°C Up	2.5°C Up	3°C Up	3.5°C Up	4°C Up
	5.6k	1.5°C Down	1°C Down	0.5°C Down	No Change	0.5°C Up	1°C Up	1.5°C Up	2°C Up	2.5°C Up	3°C Up	3.5°C Up
	8.2k	2°C Down	1.5°C Down	1°C Down	0.5°C Down	No Change	0.5°C Up	1°C Up	1.5°C Up	2°C Up	2.5°C Up	3°C Up
	10k	2.5°C Down	2°C Down	1.5°C Down	1°C Down	0.5°C Down	No Change	0.5°C Up	1°C Up	1.5°C Up	2°C Up	2.5°C Up
	12k	3°C Down	2.5°C Down	2°C Down	1.5°C Down	1°C Down	0.5°C Down	No Change	0.5°C Up	1°C Up	1.5°C Up	2°C Up
	18k	3.5°C Down	3°C Down	2.5°C Down	2°C Down	1.5°C Down	1°C Down	0.5°C Down	No Change	0.5°C Up	1°C Up	1.5°C Up
	33k	4°C Down	3.5°C Down	3°C Down	2.5°C Down	2°C Down	1.5°C Down	1°C Down	0.5°C Down	No Change	0.5°C Up	1°C Up
	56k	4.5°C Down	4°C Down	3.5°C Down	3°C Down	2.5°C Down	2°C Down	1.5°C Down	1°C Down	0.5°C Down	No Change	0.5°C Up
180k	5°C Down	4.5°C Down	4°C Down	3.5°C Down	3°C Down	2.5°C Down	2°C Down	1.5°C Down	1°C Down	0.5°C Down	No Change	

NOTE: This circuit is designed to input the necessary temperature compensation values into the MICOM. This adjusts the refrigerator temperature, which is different in each model.

8-2-8 Key Button Input & Display Light-On Circuit

The circuit shown above determines whether a function control key on the operation display is pushed. It also turns on the corresponding function indication LED DISPLAY. The drive type is the scan type.

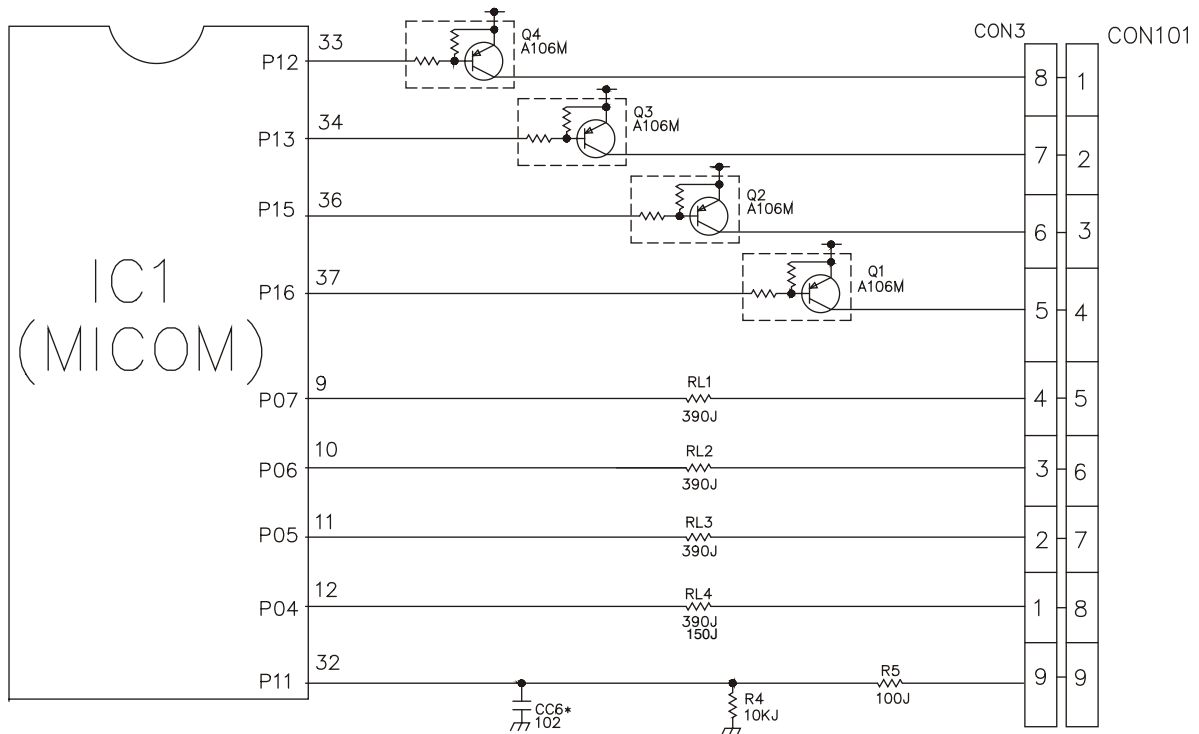

8-3 RESISTANCE SPECIFICATION OF SENSOR

TEMPERATURE DETECTED BY SENSOR	RESISTANCE OF FREEZER SENSOR	RESISTANCE OF REFRIGERATOR & DEFROST SENSOR & ROOM SENSOR
- 20° C	22.3 K Ω	77 K Ω
- 15° C	16.9 K Ω	60 K Ω
- 10° C	13.0 K Ω	47.3 K Ω
- 5° C	10.1 K Ω	38.4 K Ω
0° C	7.8 K Ω	30 K Ω
+ 5° C	6.2 K Ω	24.1 K Ω
+ 10° C	4.9 K Ω	19.5 K Ω
+ 15° C	3.9 K Ω	15.9 K Ω
+ 20° C	3.1 K Ω	13 K Ω
+ 25° C	2.5 K Ω	11 K Ω
+ 30° C	2.0 K Ω	8.9 K Ω
+ 40° C	1.4 K Ω	6.2 K Ω
+ 50° C	0.8 K Ω	4.3 K Ω

- The resistance of the SENSOR has a $\pm 5\%$ common difference.
- Measure the resistance of the SENSOR after leaving it for over 3 minutes in the measuring temperature. This delay is necessary due to sensor response speed.

8-4 TROUBLESHOOTING

PROBLEM	INDICATED BY	CHECK	CHECKING METHOD	CAUSE	SOLUTION				
POWER SOURCE is poor.	1. The whole DISPLAY LED/SEVEN SEGMENT DISPLAY's off. 2. DISPLAY LED/SEVEN SEGMENT DISPLAY operates abnormally	1. FREEZER/REFRIGERATOR.	Check if FREEZER/REFRIGERATOR DOOR IS OPEN and check display.	POWER SOURCE is poor.	Check outlet Voltage.				
		2. If LAMP is dim. 3. The connection of the MAIN PWB CONNECTOR.	Check visually. Check connection of CONNECTOR.	Applied voltage error. CONNECTOR connection is poor. TRANS FUSE is open.	Use boosting TRANS. Reconnect CONNECTOR. Replace TRANS.				
COOLING is poor.	NO COOLING.	1. If the COMPRESSOR operate.	USE TEST MODE1 (forced COOLING). If less than 7 minutes pass after compressor shuts off, don't press the KEY and wait.	COMPRESSOR locked or blocked. OLP PTC is poor. COMPRESSOR RELAY is poor. THE CONNECTING WIRE is poor.	Replace COMPRESSOR. Replace OLP PTC. Replace MAIN PWB. Check the connection of the black wire of the MAIN PWB CONNECTOR (CON2).				
			2. If refrigerant is leaking. 3. If FANMOTOR operates.	Measure the amount of frost sticking on EVAPORATOR and the surface temperature of the condenser pipe. USE TEST MODE1 (forced COOLING).	Refrigerant leakage. FAN MOTOR is poor. CONNECTING WIRE is poor.	Replace the leaking part and replace any lost refrigerant. Replace the FAN MOTOR. Certify the MOTOR and the connection of the black wire of the MAIN PWB CONNECTOR (CON2).			
FREEZER TEMPERATURE is incorrect		1. If FANMOTOR operates.	USE TEST MODE1 (forced COOLING).	FAN MOTOR is poor. CONNECTING WIRE is poor.	Replace the FAN MOTOR. Certify the MOTOR and the connection of the black wire of the MAIN PWB CONNECTOR (CON2).				
						2. If DEFROSTING is normal.	Check the amount of frost sticking on the APORATOR.	DEFROSTING is poor.	See DEFROSTING is poor.
						3. If SENSOR is normal.	Check the resistance of the Refrigerator SENSOR.	SENSOR RESISTANCE is poor.	Replace SENSOR.
						4. Door Line contact.	Check the seal when the door is closed.	Door liner damaged.	Replace door liner.

PROBLEM	INDICATED BY	CHECK	CHECKING METHOD	CAUSE	SOLUTION
COOLING is poor.	If REFRIGERATOR TEMPERATURE is too low.	1. If FREEZER TEMPERATURE isn't normal.	Check if FREEZER TEMPERATURE is too low.		Make sure the DOOR is attached.
		2. If amount of cool air from FAN MOTOR is sufficient.	Make sure that the amount and speed of cool air are sufficient by touching the check supplied on the REFRIGERATOR.	FAN MOTOR is poor. Passage of cool air is blocked. EVA frozen.	Replace FAN MOTOR. Remove impurities. See DEFROSTING is poor.
		3. Door Line contact.	Check door seal when door is closed.	Door liner damaged.	Replace Door liner.
DEFROSTING is poor.	NO DEFROSTING.	1. If HEATER emits heat.	USE TEST MODE2 (forced DEFROSTING).	HEATER disconnection.	Replace HEATER.
				TEMPERATURE FUSE disconnection.	Replace TEMPERATURE FUSE.
				Connection is poor.	Check EVAPORATOR connection and wire of MAIN PWB CONNECTOR.
				DEFROST-SENSOR is poor.	Replace DEFROST-SENSOR.
				HEATER RELAY is poor.	Replace RY3 of MAIN PWB.
				DRAIN PIPE is blocked.	Remove ice and impurities. Check HEATER PLATE resistance.
				Connection is poor.	Reassemble the DEFROST-SENSOR.
				DOOR does not close properly.	Reassemble DOOR. Replace GASKET.
				Make sure that DEFROST SENSOR is connected.	
				Make sure that FREEZER / REFRIGERATOR DOOR is closed.	
3. If ice remains after DEFROSTING.					

8-5 MAIN PWB ASSEMBLY AND PARTS LIST

8-5-1 Main PWB Assembly

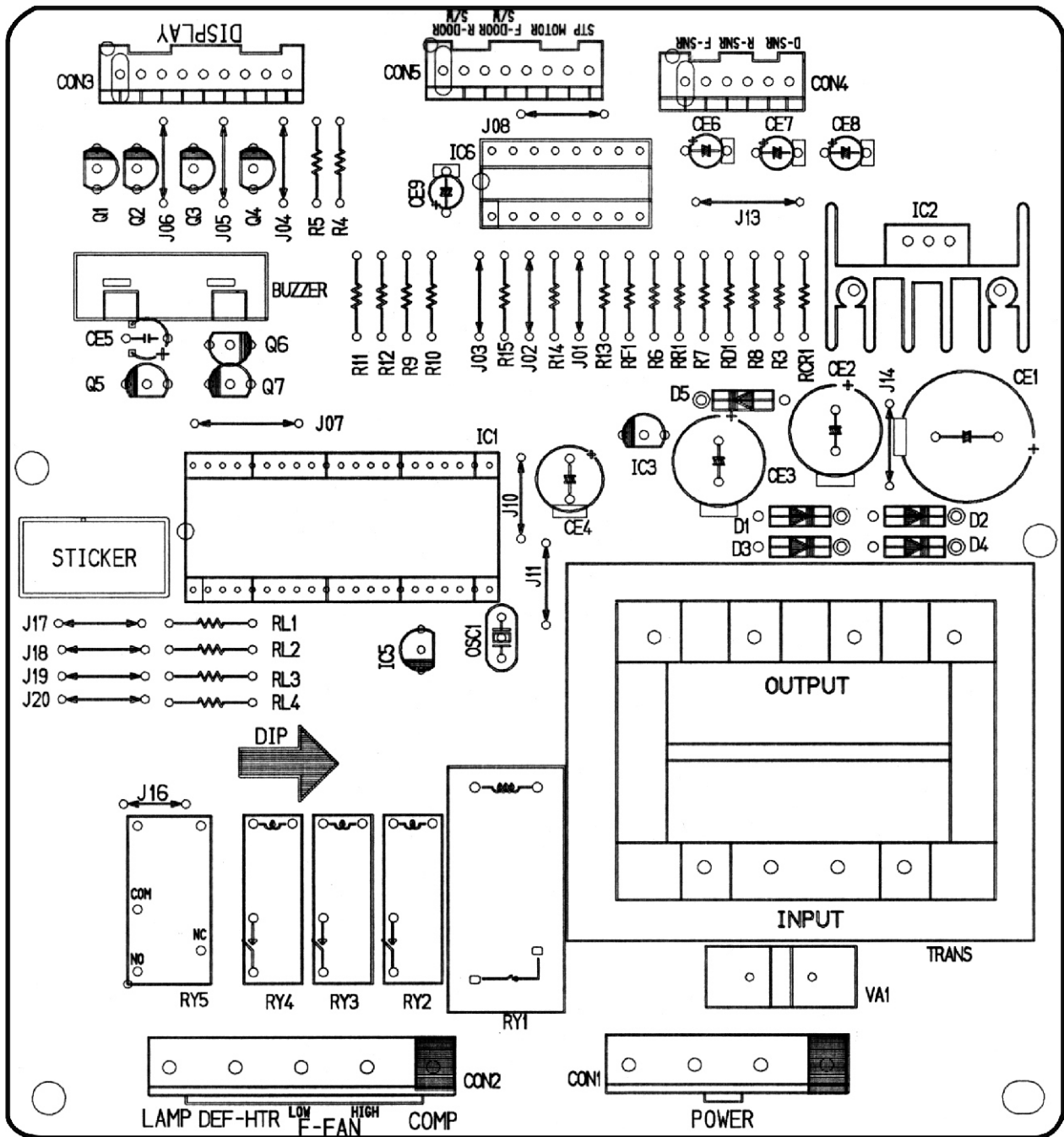

8-5-2 Replacement Parts List

No	P/NO	DESCRIPTION	SPEC	MAKER	REMARK
1	6670_BB089A = C	PWB(PCB)	KS-PJT GOOD MDL	DOO SAN	T-1.6
2	-	-	-	-	-
3	6170_B2002H	TRANSFORMER,LOW VOLTAGE	240V 15V YES GR-MICOM ONE TAB	TAE SUNG	TRANS
4	6170_B2002M	TRANSFORMER,LOW VOLTAGE	260V 15V YES GR-MICOM ONE TAB	TAE SUNG	TRANS
5	6170_B2002R	TRANSFORMER,LOW VOLTAGE	140V 15V YES GR-MICOM ONE TAB	TAE SUNG	TRANS
6	6170_B2002W	TRANSFORMER,LOW VOLTAGE	115V 15V YES GR-MICOM ONE TAB	TAE SUNG	TRANS
7	-	-	-	-	-
8	6630A0910C	CONNECTOR (CIRC),WAFER	YW396-07AV YEONHO 7PIN 3.96MM STRAIGHT SN	YEON HO	CON1
9	6630A0910D	CONNECTOR (CIRC),WAFER	YW396-09AV	YEON HO	CON2
10	6630A0910E	CONNECTOR (CIRC),WAFER	YW396-05AV	YEON HO	-
11	6630_BB007G	CONNECTOR (CIRC),WAFER	917786-1 AMP 8PIN 2.5MM STRAIGHT SN	AMP	CON5
12	6630_BB007H	CONNECTOR (CIRC),WAFER	917787-1 AMP 9PIN 2.5MM STRAIGHT SN	AMP	CON3
13	6630_BB007E	CONNECTOR (CIRC),WAFER	917784-1 AMP 6PIN 2.5MM STRAIGHT SN	AMP	CON4
14	-	-	-	-	-
15	01ZZ_B2023L	IC,DRAWING	TMF97C846N 42 SDIP BK KS-BETTER/GOOD(MASK)	TOSHIBA	IC1(01ZZ_B2022M)
16	01ZZ_B2022	IC,DRAWING	-	TOSHIBA	IC1(01ZZ_B2022)
17	01ZZ_B2022	IC,DRAWING	-	TOSHIBA	IC1(01ZZ_B2022)
18	-	-	-	-	-
19	01KE781200B	IC,KEC	K1A7812P1 12V 1A,KEC - - - -	KEC	IC2
20	01KE781200M	IC,KEC	K1A7812P1 3DIP BK 12V 1A REFORM	KEC	-
21	01KE780500A	IC,KEC	K1A7805SP,3PIN,DIP, KEC	KEC	IC3
22	01STLM001A	IC,STANDARD LOGIC	M45563FP MITSUBISHI 20 R/TIP CONVERT	MITSUBISHI	-
23	01T0777400A	IC,TOSHIBA	T17774AP 16 SDIP BK STEPPING MOTOR	TOSHIBA	IC6
24	01KE650030C	IC,KEC	K1D65003AF 1650P BK 7OH DRIVER	KEC	IC4
25	01KE704200A	IC,KEC	K1A7042P 3P BK RESET	KEC	IC5
26	01RH934600D	IC,ROHM	BR93LC46FF-W 8PIN SOP BK EEPROM -	ROHM	-
27	-	-	-	-	-
28	6920000001A	RELAY	ALE15B12 MATSUSHITA 250VAC 16A 12VDC IA NO VENTING	NAIS	RY1
29	6920WF0010A	RELAY	US11-12S YUYU 250VAC 3A 12VDC IA	YUYU	-
30	6920_B2003E	RELAY	ALD112 MATSUSHITA 250VAC 3A 12VDC IA	OMRON	RY2-RY4
31	6920_B2009A = B	RELAY	655B-14 250VAC 5A 12VDC IC	OMRON	RY5
32	-	-	-	-	-
33	-	-	-	-	-
34	6212_BB001B	RESONATOR,CERAMIC	CST50400 MURATA 4MHZ +/- 0.5% 15PF TP NONE	MURATA	OSC1(LJ570-0001ZB)
35	6102W5V006A	VARIATOR	1NR14D331 ILJIN UL/CSA/VDE BK	ILJIN	VA1
36	6102_BB003A	VARIATOR	1NR14D271 ILJIN UL/VDE TP 270V	ILJIN	VA1
37	6102_BB001B	VARIATOR	1NR14D621 ILJIN UL/VDE BK 620V	ILJIN	VA1
38	0DD400709AA	DIODE,RECTIFIERS	1N4007 TP MOTOROLA - - IA - - -	DELTA	DI-05
39	-	-	-	-	-
40	-	-	-	-	-
41	0CE2286J610	CAPACITOR,AL-ELECTROLYTIC	2200 UF SWS,S6 35V M FL BULK	SAM HWA	CE1
42	0CE1086J610	CAPACITOR,AL-ELECTROLYTIC	1000UF SWS,S6 35V 20% FL BULK	SAM HWA	-
43	0CE1086H61B	CAPACITOR,AL-ELECTROLYTIC	1000 UF SWS,S6 25V M FL TP 5	SAM HWA	CE2
44	0CE4776H61B	CAPACITOR,FIXED ELECTROLYTIC	470UF SWS,S6 25V 20% FL TP 5	SAM HWA	CE3
45	0CE2276F63B	CAPACITOR,FIXED ELECTROLYTIC	220UF SWS,S6 16V 20% FM5 TP 5	SAM HWA	CE4
46	0CE1076H63B	CAPACITOR,FIXED ELECTROLYTIC	100UF SWS,S6 25V 20% FM5 TP 5	SAM HWA	-
47	0CE1066K63B	CAPACITOR,FIXED ELECTROLYTIC	10UF SWS,S6 50V 20% FM5 TP 5	SAM HWA	CE6-CE8
48	0CE1056K63B	CAPACITOR,FIXED ELECTROLYTIC	1UF SWS,S6 50V 20% FM5 TP 5	SAM HWA	CE9
49	0CE4761H63B	CAPACITOR,FIXED ELECTROLYTIC	47UF SWS,S6 25V 20% FM5 TP 5	SAM HWA	CE5
50	0C02231N409	CAPACITOR,POLYESTER	0.022 UF D 100V J PE TP	SAM HWA	-
51	0CK1020K96A	CAPACITOR,FIXED CERAMIC(HIGH DIELECTRIC)	1NF 2012 50V 80%, -20% R/TP X7R	-	CC6
52	0CK2230K96A	CAPACITOR,FIXED CERAMIC(HIGH DIELECTRIC)	22NF 2012 50V 80%, -20% R/TP X7R	MURATA	CC7-CC11
53	-	-	-	-	-
54	0CK1040K94A	CAPACITOR,FIXED CERAMIC(HIGH DIELECTRIC)	100NF 2012 50V R/TP (GRM40X7R104K50PE)	MURATA	CC1-CC5
55	-	-	-	-	-
56	0CK1040K949	CAPACITOR,FIXED CERAMIC(HIGH DIELECTRIC)	0.1UF D 50V 80%, -20% F(Y5V) TA52	-	-
57	-	-	-	MURATA	-
58	-	-	-	-	-
59	0RD1500G609	RESISTOR,FIXED CARBON FILM	150 OHM 1/4W 5.00% TA52	SMART	RL4
60	0RD3900G609	RESISTOR,FIXED CARBON FILM	390 OHM 1/4 W 5.00% TA52	SMART	RL1-RL3
61	0RD1000G609	RESISTOR,FIXED CARBON FILM	100 OHM 1/4 W 5.00% TA52	SMART	R5
62	0RJ001E672	RESISTOR,METAL GLAZED(CHIP)	1K OHM 1/8 W 5% 2012 R/TP	ROHM	RI6
63	0RJ2001E672	RESISTOR,METAL GLAZED(CHIP)	2K OHM 1/8 W 5% 2012 R/TP	ROHM	-
64	0RD2001G609	RESISTOR,FIXED CARBON FILM	2K OHM 1/4 W 5.00% TA52	SMART	R6-RI2
65	0RH2200L622	RESISTOR,METAL GLAZED(CHIP)	220 OHM 1/8 W 2012 5.00% D	ROHM	RI7
66	0RJ2201E672	RESISTOR,METAL GLAZED(CHIP)	2.2K OHM 1/8 W 5% 2012 R/TP	ROHM	RI1
67	0RJ4701E672	RESISTOR,METAL GLAZED(CHIP)	4.7K OHM 1/8 W 5% 2012 R/TP	ROHM	RI
68	0RJ4701E672	RESISTOR,METAL GLAZED(CHIP)	4.7K OHM 1/8 W 5% 2012 R/TP	ROHM	-
69	0RD4701G609	RESISTOR,FIXED CARBON FILM	4.7K OHM 1/4 W 5.00% TA52	SMART	-
70	0RJ1002E672	RESISTOR,METAL GLAZED(CHIP)	10K OHM 1/8 W 5% 2012 R/TP	ROHM	-
71	0RJ1002E672	RESISTOR,METAL GLAZED(CHIP)	10K OHM 1/8 W 5% 2012 R/TP	ROHM	-
72	0RD1002G609	RESISTOR,FIXED CARBON FILM	10K OHM 1/4 W 5.00% TA52	SMART	R3,R4,RCR1,RI3-RI5
73	0RJ2702E672	RESISTOR,METAL GLAZED(CHIP)	27K OHM 1/8 W 5% 2012 R/TP	ROHM	-
74	0RJ004E672	RESISTOR,METAL GLAZED(CHIP)	1M OHM 1/8 W 5% 2012 R/TP	ROHM	R2
75	0RJ2612E472	RESISTOR,FIXED METAL FILM	26.1K OHM 1/4 W 1.00% TA52	SMART	RF1,RF1
76	0RJ1622E472	RESISTOR,FIXED METAL FILM	16.2K OHM 1/4 W 1.00% TA52	SMART	RF1
77	-	-	-	-	-
78	-	-	-	-	-
79	3J03565D	FUSE,DRAWING	9A 250V - -	SAM JU	-
80	0TRI06009AC	TRANSISTOR	KRA106M1KRA2206) TP KEC	KEC	Q1-Q4
81	0TRI06009AF	TRANSISTOR	KRC 106M KEC	KEC	Q5,Q7
82	0TR319809AA	TRANSISTOR	KTC3198-TP-Y (KTC1815)KEC	KEC	-
83	6908_B3002F	BUZZER	CR622208P DAE YOUNG P1E20 2KHZ 750B(CHINA)	DAE YOUNG	BUZZER
84	6600RR1001Z	SWITCH,TACT	JTP1280A6 JEIL 12V DC 50MA	JEIL	-
85	6854B50001A	JUMP WIRE	0.6MM 52MM TP TAPING SN(10MM)	-	J16
86	6854B50001A	JUMP WIRE	0.6MM 52MM TP TAPING SN(10MM)	-	J1-J6,J8,J10,J14,J17-J20
87	6854B50001A	JUMP WIRE	0.6MM 52MM TP TAPING SN(12.5MM)	-	J13
88	6854B50001A	JUMP WIRE	0.6MM 52MM TP TAPING SN(12.5MM)	-	J07
89	6854B50001A	JUMP WIRE	0.6MM 52MM TP TAPING SN	-	-
90	6854B50001A	JUMP WIRE	0.6MM 52MM TP TAPING SN	-	-
91	4920_B3003A	HEAT SINK	30*25*30 IC-12V R-850,51,52,53,54,55,56 2PIN 1-SCREW 3	-	(IC2)
92	15BF030241B	SCREW TAP TITE(S),BINDING HEAD	+ D3.0 L8.0 MSWR3/FZY	-	(IC2)
93	9VWF0120000	SOLDER(ROSN WIRE) R50	DI,20	HEE SUNG	-
94	49111004	SOLDER,SOLDERING	H63A	-	-
95	59333105	FLUX	SG10.825-0.830 KOREA F.H-206	KOKI	-

8-5-3 PWB Assembly, Dysplay and Parts List

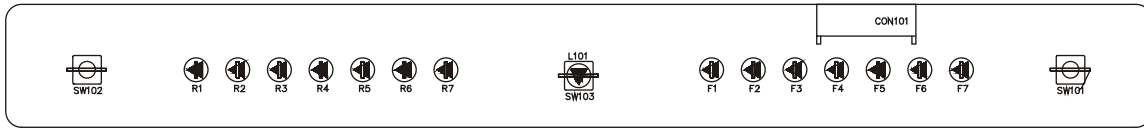

Qty	No	P/NO	DESCRIPTION	SPEC	MAKER	REMARK
1	1	6870JB8091A	PWB(PCB)	KS-PJT GOOD/BETTER DISPLAY	DOO SAN	t=1.6
	2					
1	3	6630AQ9159H	WAFER	SMAW250-09	YEON HD	CON101
	4					
2	5	6600RRT002K 6600JB8005A	SWITCH,TACT	JTP1230A JEIL 12V DC 50MA KPT-1105A	JEIL KYUNG IN	SW101,102
1	6	-	TACT S/W	KPT-1109G	KYUNG IN	SW103
14	7	0DLLE0019AA	LED	LT1824-81-BCM TP GREEN 2		R1~R7,F1~F7
3	8	0DD414809AA	DIODE,SWITCHING	1N4148 26MM	PYUNG CHANG DELTA	D101,102,103
12	10	6854B50001A	JUMP WIRE	0.6MM 52MM TP TAPING SN (10MM)	-	J101~J112
	11					
-	12	9VWF0120000	SOLDER(ROSIN WIRE) RSO	D1.20	HEE SUNG	-
001	13	49111004	SOLDER,SOLDERING	H63A	-	-
0.0005	14	59333105	FLUX	SG;0.825-0.830 KOREA F.H-206	KOKI	-

8-6 PWB DIAGRAM

8-6-1 PWB Main Assembly

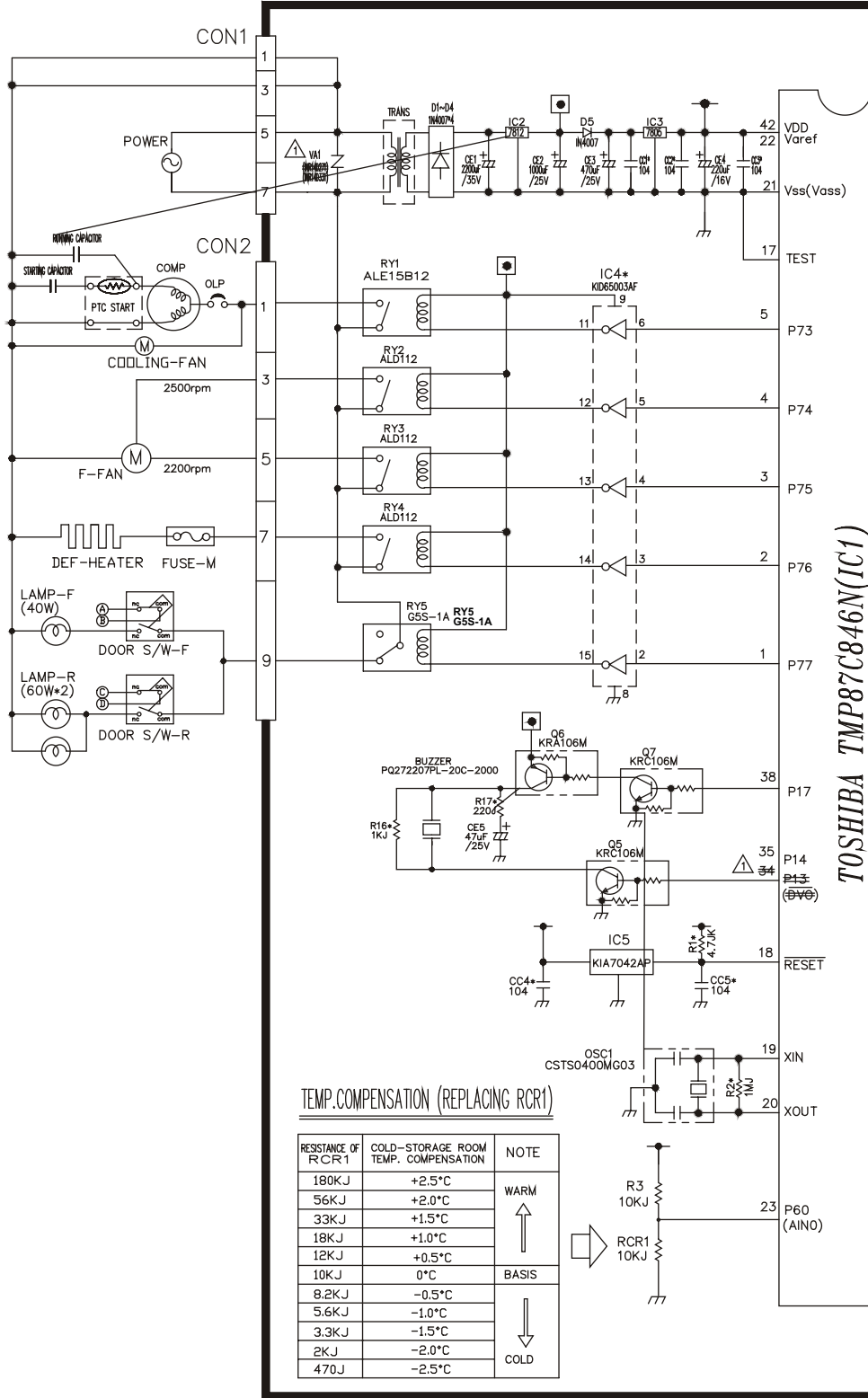

TOSHIBA TMP87C846N(IC1)

FIG.1 CIRCUIT DIAGRAM

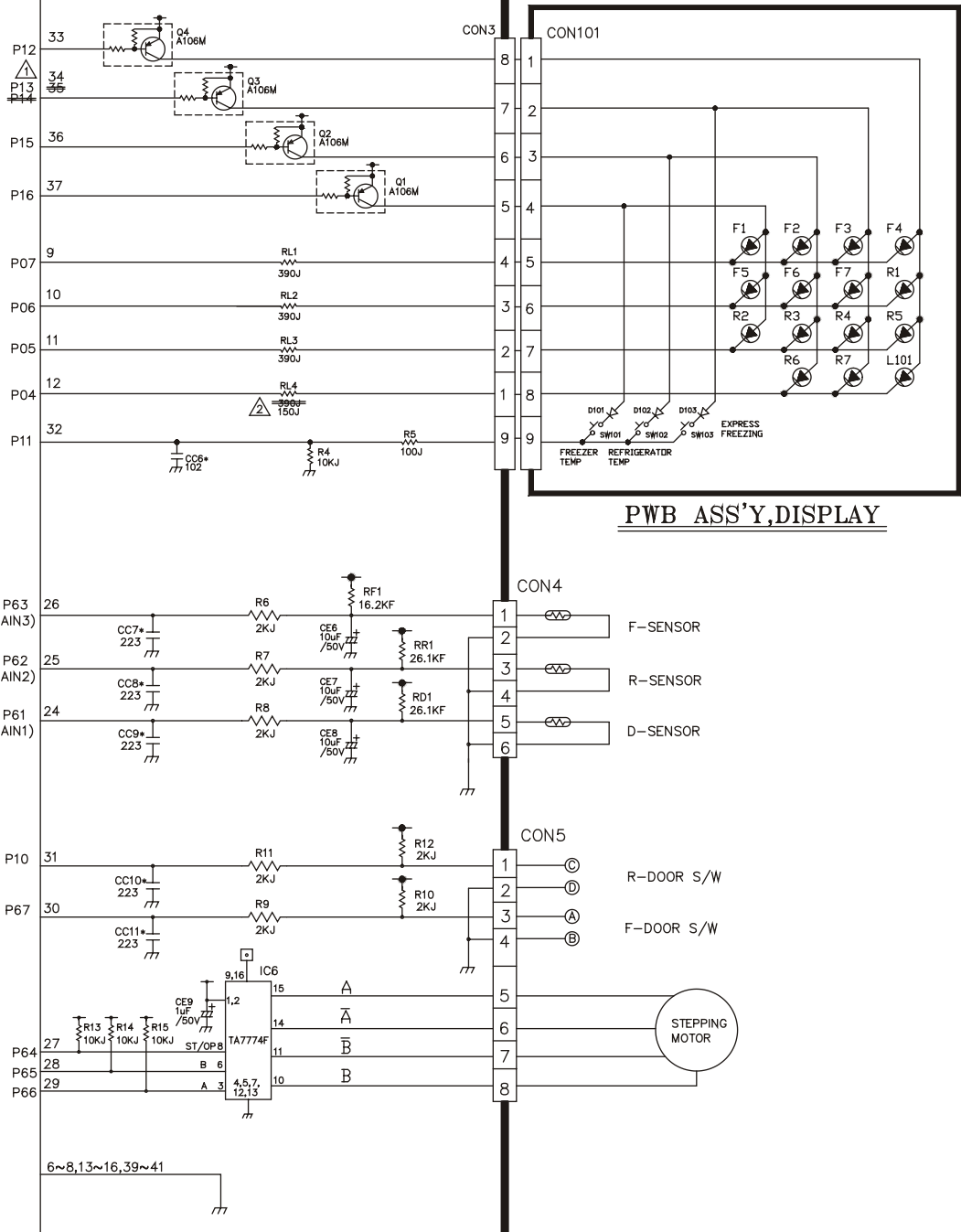

EXPLODED VIEW

CASE PARTS

CAUTION: Use the part number to order part, not the position number.

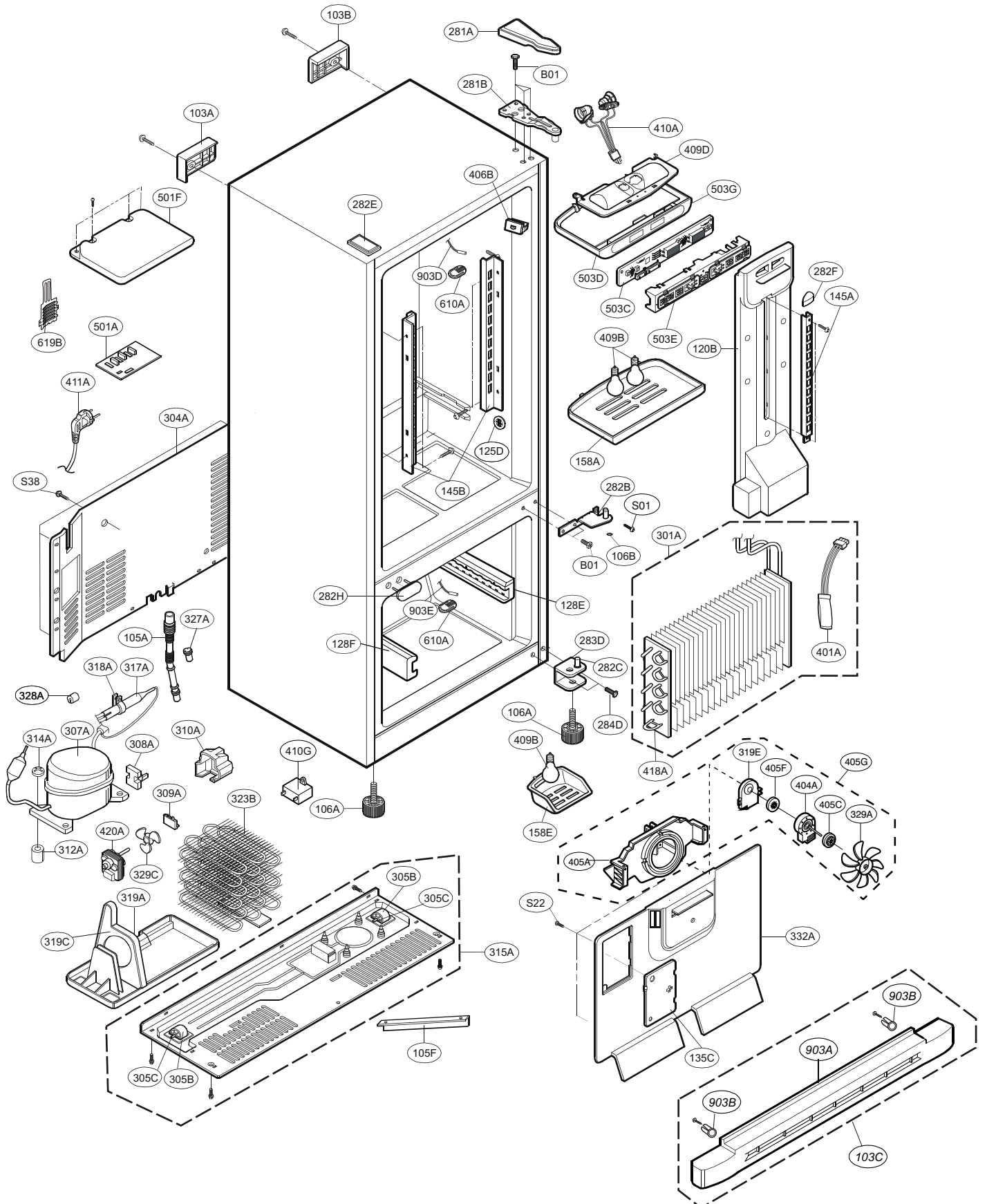

FREEZER PARTS

CAUTION: Use the part number to order part, not the position number.

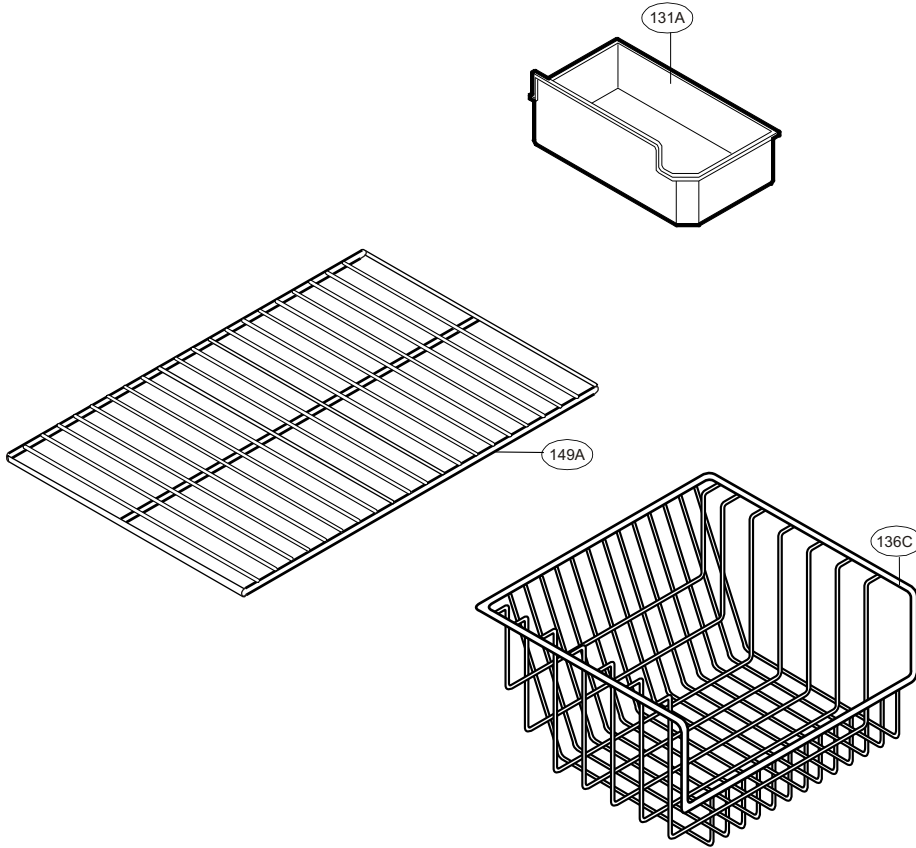

REFRIGERATOR PARTS

CAUTION: Use the part number to order part, not the position number.

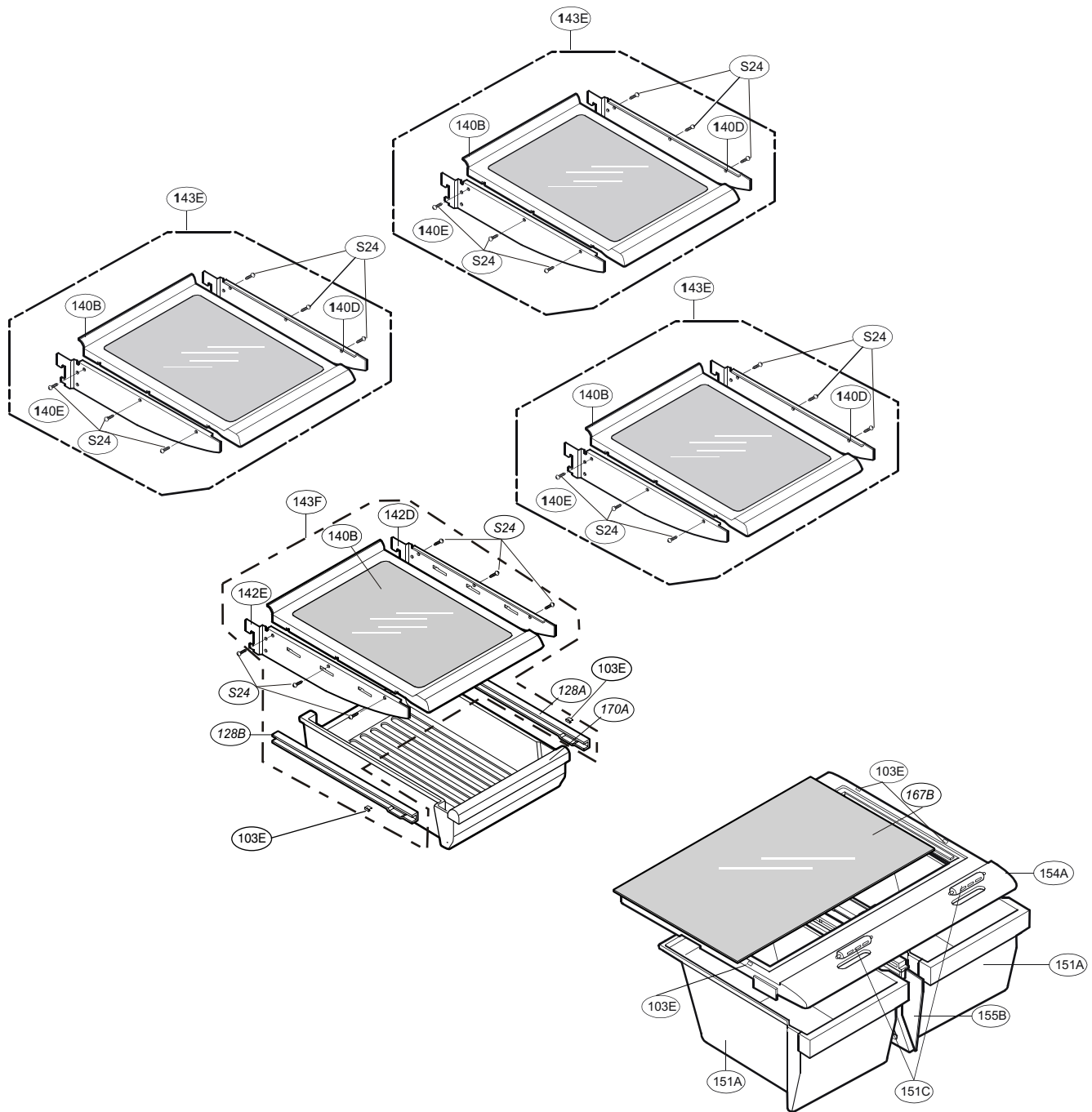

DOOR PARTS(Swing)

CAUTION: Use the part number to order part, not the position number.

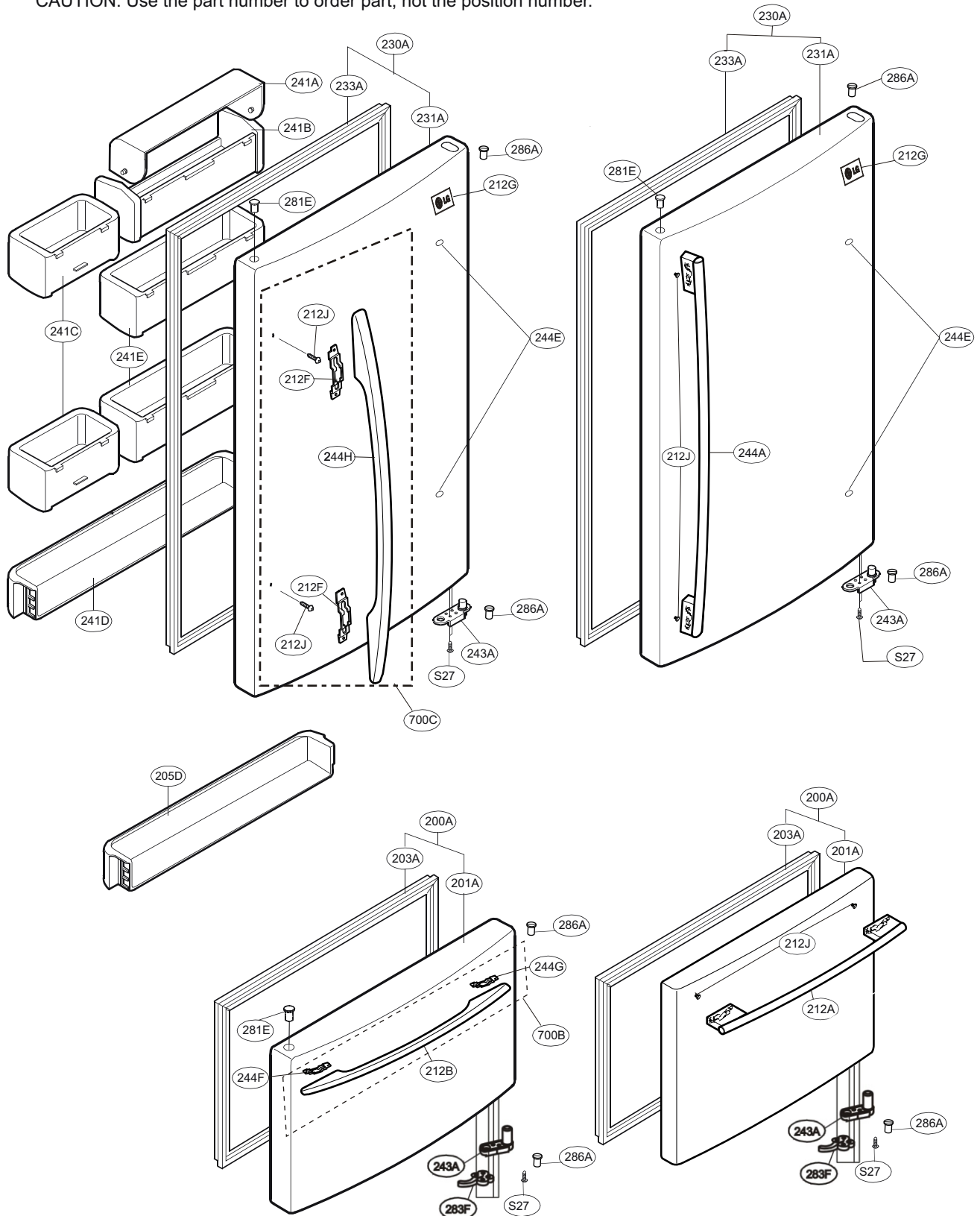

WATER and ICE MAKER PARTS

CAUTION: Use the part number to order part, not the position number.

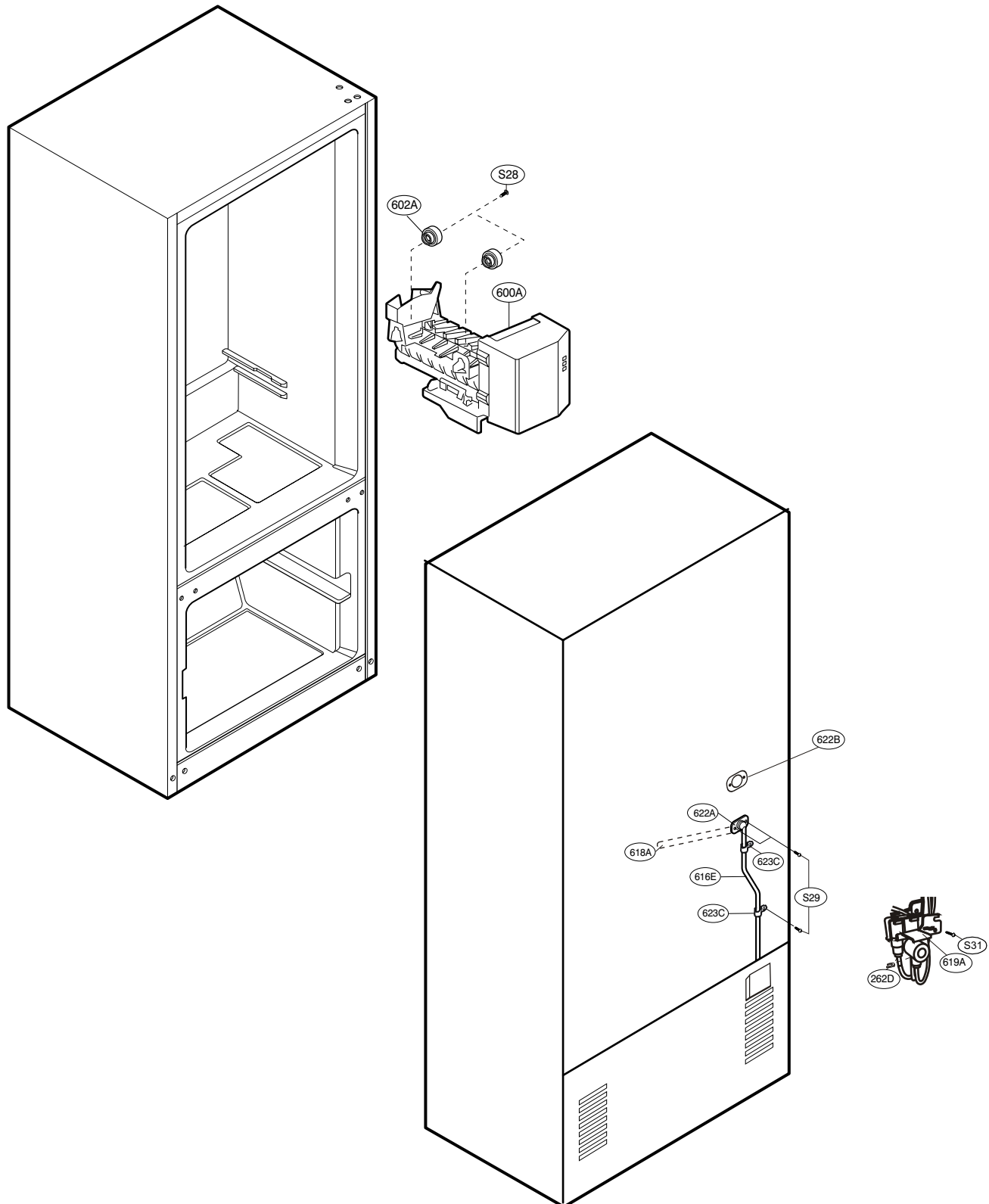

LBC22518WW

Loc No	Part No	Description	Loc No	Part No	Description
103A	3650JJ2003E	HANDLE,REAR	284D	1STZJA3004K	SCREW,CUSTOMZIED
103B	3650JJ2003A	HANDLE,REAR	286A	4984JJ3003A	BUSH
103C	3551JJ1015B	COVER ASSEMBLY,LOWER	301A	5421JJ1001B	EVAPORATOR ASSEMBLY
103E	5218JJ3001A	RAIL,SLIDE	304A	3551JJ2008B	COVER ASSEMBLY,MACHINERY(REAR)
105A	5251JA3003B	TUBE ASSEMBLY,DRAIN	305B	4580JJ3001A	ROLLER
105F	5070JJ3002A	SKIRT,LOWER	305C	4J04238A	PIN,COMMON
106A	4779JA2003A	LEG ASSEMBLY,ADJUST	307A	2521JJ8004A	COMPRESSOR,SET ASSEMBLY
106B	4J00382C	WASHER,COMMON	308A	6748JJ8002A	THERMISTOR,PTC
120B	5209JJ1002A	DUCT ASSEMBLY,MULTI	309A	6750JJ8002A	OVERLOAD PROTECT
125D	4930JJ3007A	HOLDER,BRACKET	310A	3550JJ8003A	COVER,PTC
128A	4975JJ2002A	GUIDE ASSEMBLY,RAIL	312A	5040JA3031A	DAMPER,COMPRESSOR
128B	4975JJ2002B	GUIDE ASSEMBLY,RAIL	314A	4620JA3009A	STOPPER,COMPRESSOR
128E	4975JJ2009A	GUIDE ASSEMBLY,RAIL	315A	3103JJ1001J	BASE ASSEMBLY,COMPRESSOR
128F	4975JJ2009B	GUIDE ASSEMBLY,RAIL	317A	5851JJ2002B	DRIER ASSEMBLY
131A	5074JJ1017A	BUCKET,ICE	318A	4930JJ3002A	HOLDER,DRIER
135C	3550JJ2030A	COVER,GRILLE FAN	319A	3390JJ0003A	TRAY,DRIP
136C	3390JJ1057A	TRAY,DRAWER	319C	4974JJ1009A	GUIDE,FAN
140B	5027JJ2007B	SHELF ASSEMBLY,REFRIGERATOR	319E	4810JJ2005A	BRACKET,MOTOR
140D	5026JJ2001G	SHELF,NET	323B	5403JJ1007A	CONDENSER ASSEMBLY,WIRE
140E	5026JJ2001H	SHELF,NET	327A	5006JA3034A	CAP,DRAIN TUBE
142D	5026JJ2001L	SHELF,NET	328A	4J03020A	DAMPER,PIPE
142E	5026JJ2001M	SHELF,NET	329A	5901JJ1005A	FAN ASSEMBLY
143E	5027JJ1008B	SHELF ASSEMBLY,REFRIGERATOR	329C	5901JJ1004B	FAN ASSEMBLY
143F	5027JJ1008D	SHELF ASSEMBLY,REFRIGERATOR	332A	3531JJ1004A	GRILLE ASSEMBLY,FAN
145A	4930JJ2003A	HOLDER,SHELF	401A	6615JB2005C	CONTROLLER ASSEMBLY,CIRCUIT
145B	4930JJ2004A	HOLDER,SHELF	404A	4681JK1004A	AC MOTOR
149A	5026JJ1026A	SHELF,FREEZER	405A	4811JJ2002A	BRACKET ASSEMBLY,MOTOR
151A	3391JJ1020C	TRAY ASSEMBLY,VEGETABLE	405C	5040JA2009B	DAMPER,MOTOR SUPPORT
151C	4940JJ2003C	KNOB,SHUTTER	405F	5040JA2004B	DAMPER,MOTOR SUPPORT
154A	3550JL1006C	COVER,TV	405G	4811JJ2002H	BRACKET ASSEMBLY,MOTOR
155B	4981JJ2001B	SUPPORTER ASSEMBLY,COVER TV	406B	6600JB1004A	SWITCH,PUSH BUTTON
158A	3550JJ1040A	COVER,LAMP	409B	6912JK2002C	LAMP,INCANDESCENT
158E	3550JJ1051A	COVER,LAMP	409D	3034JJ1002B	REFLECTOR,LAMP
167B	4890JL1002H	SHELF,GLASS	410A	6621JK2002D	DRAWING,ASSEMBLY
170A	3391JJ2004H	TRAY ASSEMBLY,MEAT	410G	0CZZJK2001A	CAPACITOR,FILM,BOX
200A	3581JJ8020J	DOOR ASSEMBLY,FREEZER	411A	6411JK1006A	POWER CORD ASSEMBLY
201A	5433JJ0060A	DOOR FOAM ASSEMBLY,FREEZER	418A	5300JB1100J	HEATER,SHEATH
203A	4987JJ1004A	GASKET ASSEMBLY,DOOR	420A	4680JK1001B	AC MOTOR
205D	5004JJ1040A	BASKET,DOOR	501A	6871JB1213E	PCB ASSEMBLY,MAIN
212B	3650JJ0019A	HANDLE,FREEZER	501F	3550JJ1042B	COVER,PCB
212F	4810JJ3015A	BRACKET,HANDLE	503C	6871JB2047A	PCB ASSEMBLY,DISPLAY
212G	3846JD1007B	NAME PLATE	503D	3110JJ1005A	CASE,DISPLAY
212J	4620JJ3007A	STOPPER,HANDLE	503E	3550JJ2031A	COVER,DISPLAY
230A	3581JJ8047A	DOOR ASSEMBLY,REFRIGERATOR	503G	3806JL1009B	DECOR,CONTROL
231A	5433JJ0019M	DOOR FOAM ASSEMBLY,REFRIGERATOR	600A	5989JA0002N	ICE MAKER ASSEMBLY,KIT
233A	4987JJ1004B	GASKET ASSEMBLY,DOOR	602A	4930JA3037A	HOLDER,BRACKET
241A	3550JL2003H	COVER,TRAY	610A	3550JJ2020A	COVER,SENSOR
241B	5004JJ1021A	BASKET,DOOR	616E	5210JA3005N	TUBE,PLASTIC
241C	5005JJ2017A	BASKET ASSEMBLY,DOOR	618A	5210JJ3005B	TUBE,INJECT
241D	5005JJ2020A	BASKET ASSEMBLY,DOOR	619A	5220JA2009D	VALVE,WATER
241E	5005JJ2018A	BASKET ASSEMBLY,DOOR	619B	3550JJ2024A	COVER,VALVE
243A	4620JJ3006A	STOPPER,DOOR	622A	5040JA2015A	RUBBER,INJECT
243A	4620JJ3006A	STOPPER,DOOR	622B	4810JA3036A	BRACKET,COVER
244E	5006JJ3016A	CAP,HANDLE	623C	4770JA3001A	BAND
244F	4810JJ2011B	BRACKET,HANDLE	700B	3651JJ2016D	HANDLE ASSEMBLY,FREEZER
244G	4810JJ2011A	BRACKET,HANDLE	700C	3651JJ2015D	HANDLE ASSEMBLY,REFRIGERATOR
244H	3650JJ0020A	HANDLE,REFRIGERATOR	903A	3550JJ0006A	COVER,LOWER
262D	4004JA3002A	CLIP	903B	4930JJ2021A	HOLDER,COVER(LOWER)
281A	3550JJ2013A	COVER,HINGE	903D	6500JK1003A	SENSOR
281B	4775JJ2003B	HINGE ASSEMBLY,UPPER	903E	6500JK1004A	SENSOR
281E	5006JJ3008A	CAP,HINGE	B01	1STZJA3004F	SCREW,CUSTOMZIED
282B	4775JJ8002F	HINGE ASSEMBLY,CENTER	S01	1SZZJJ3010A	SCREW,CUSTOMZIED
282C	1PZZJJ3002F	PIN,COMMON	S22	J471-00001J	SCREW,CUSTOMZIED
282E	5006JJ2001A	CAP,HINGE	S24	1SZZJA3011B	SCREW,CUSTOMZIED
282F	3806JL2006F	DECOR,DUCT	S27	4J01424C	SCREW,CUSTOMZIED
282H	5006JJ3004A	CAP,HINGE	S28	1SZZJJ3005E	SCREW,CUSTOMZIED
283D	4774JJ2002A	HINGE,LOWER	S29	4J00415D	SCREW,CUSTOMZIED
283F	4620JJ2007A	STOPPER,DOOR	S31	4000W4A003A	SCREW,CUSTOMZIED
			S38	4J00415D	SCREW,CUSTOMZIED

Loc No	Part No	Description	Loc No	Part No	Description
103A	3650JJ2003M	HANDLE,REAR	286A	4984JJ3003A	BUSH
103B	3650JJ2003L	HANDLE,REAR	301A	5421JJ1001B	EVAPORATOR ASSEMBLY
103C	3551JJ1015F	COVER ASSEMBLY,LOWER	304A	3551JJ2008B	COVER ASSEMBLY,MACHINERY(REAR)
103E	5218JJ3001A	RAIL,SLIDE	305B	4580JJ3001A	ROLLER
105A	5251JA3003B	TUBE ASSEMBLY,DRAIN	305C	4J04238A	PIN,COMMON
105F	5070JJ3002A	SKIRT,LOWER	307A	2521JJ8004A	COMPRESSOR,SET ASSEMBLY
106A	4779JA2003A	LEG ASSEMBLY,ADJUST	308A	6748JJ8002A	THERMISTOR,PTC
106B	4J00382C	WASHER,COMMON	309A	6750JJ8002A	OVERLOAD PROTECT
120B	5209JJ1002A	DUCT ASSEMBLY,MULTI	310A	3550JJ8003A	COVER,PTC
125D	4930JJ3007A	HOLDER,BRACKET	312A	5040JA3031A	DAMPER,COMPRESSOR
128A	4975JJ2002A	GUIDE ASSEMBLY,RAIL	314A	4620JA3009A	STOPPER,COMPRESSOR
128B	4975JJ2002B	GUIDE ASSEMBLY,RAIL	315A	3103JJ1001J	BASE ASSEMBLY,COMPRESSOR
128E	4975JJ2009A	GUIDE ASSEMBLY,RAIL	317A	5851JJ2002B	DRIER ASSEMBLY
128F	4975JJ2009B	GUIDE ASSEMBLY,RAIL	318A	4930JJ3002A	HOLDER,DRIER
131A	5074JJ1017A	BUCKET,ICE	319A	3390JJ0003A	TRAY,DRIP
135C	3550JJ2030A	COVER,GRILLE FAN	319C	4974JJ1009A	GUIDE,FAN
136C	3390JJ1057A	TRAY,DRAWER	319E	4810JJ2005A	BRACKET,MOTOR
140B	5027JJ2007B	SHELF ASSEMBLY,REFRIGERATOR	323B	5403JJ1007A	CONDENSER ASSEMBLY,WIRE
140D	5026JJ2001G	SHELF,NET	327A	5006JA3034A	CAP,DRAIN TUBE
140E	5026JJ2001H	SHELF,NET	328A	4J03020A	DAMPER,PIPE
142D	5026JJ2001L	SHELF,NET	329A	5901JJ1005A	FAN ASSEMBLY
142E	5026JJ2001M	SHELF,NET	329C	5901JJ1004B	FAN ASSEMBLY
143E	5027JJ1008B	SHELF ASSEMBLY,REFRIGERATOR	332A	3531JJ1004A	GRILLE ASSEMBLY,FAN
143F	5027JJ1008D	SHELF ASSEMBLY,REFRIGERATOR	401A	6615JB2005C	CONTROLLER ASSEMBLY,CIRCUIT
145A	4930JJ2003A	HOLDER,SHELF	404A	4681JK1004A	AC MOTOR
145B	4930JJ2004A	HOLDER,SHELF	405A	4811JJ2002A	BRACKET ASSEMBLY,MOTOR
149A	5026JJ1026A	SHELF,FREEZER	405C	5040JA2009B	DAMPER,MOTOR SUPPORT
151A	3391JJ1020C	TRAY ASSEMBLY,VEGETABLE	405F	5040JA2004B	DAMPER,MOTOR SUPPORT
151C	4940JJ2003C	KNOB,SHUTTER	405G	4811JJ2002H	BRACKET ASSEMBLY,MOTOR
154A	3550JL1006C	COVER,TV	406B	6600JB1004A	SWITCH,PUSH BUTTON
155B	4981JJ2001B	SUPPORTER ASSEMBLY,COVER TV	409B	6912JK2002C	LAMP,INCANDESCENT
158A	3550JJ1040A	COVER,LAMP	409D	3034JJ1002B	REFLECTOR,LAMP
158E	3550JJ1051A	COVER,LAMP	410A	6621JK2002D	DRAWING,ASSEMBLY
167B	4890JL1002H	SHELF,GLASS	410G	0CZZJK2001A	CAPACITOR,FILM,BOX
170A	3391JJ2004H	TRAY ASSEMBLY,MEAT	411A	6411JK1006A	POWER CORD ASSEMBLY
200A	3581JJ8020H	DOOR ASSEMBLY,FREEZER	418A	5300JB1100J	HEATER,SHEATH
201A	5433JJ0058G	DOOR FOAM ASSEMBLY,FREEZER	420A	4680JK1001B	AC MOTOR
203A	4987JJ1004E	GASKET ASSEMBLY,DOOR	501A	6871JB1213E	PCB ASSEMBLY,MAIN
205D	5004JJ1040A	BASKET,DOOR	501F	3550JJ1042B	COVER,PCB
212A	3651JA1033J	HANDLE ASSEMBLY,FREEZER	503C	6871JB2047A	PCB ASSEMBLY,DISPLAY
212G	3846JD1007E	NAME PLATE	503D	3110JJ1005A	CASE,DISPLAY
212J	4620JJ3007A	STOPPER,HANDLE	503E	3550JJ2031A	COVER,DISPLAY
230A	3581JJ8716C	DOOR ASSEMBLY,REFRIGERATOR	503G	3806JL1009B	DECOR,CONTROL
231A	5433JJ0019Z	DOOR FOAM ASSEMBLY,REFRIGERATOR	600A	5989JA0002N	ICE MAKER ASSEMBLY,KIT
233A	4987JJ1004F	GASKET ASSEMBLY,DOOR	602A	4930JA3037A	HOLDER,BRACKET
241A	3550JL2003H	COVER,TRAY	610A	3550JJ2020A	COVER,SENSOR
241B	5004JJ1021A	BASKET,DOOR	616E	5210JA3005N	TUBE,PLASTIC
241C	5005JJ2017A	BASKET ASSEMBLY,DOOR	618A	5210JJ3005B	TUBE,INJECT
241D	5005JJ2020A	BASKET ASSEMBLY,DOOR	619A	5220JA2009D	VALVE,WATER
241E	5005JJ2018A	BASKET ASSEMBLY,DOOR	619B	3550JJ2024A	COVER,VALVE
243A	4620JJ3006C	STOPPER,DOOR	622A	5040JA2015A	RUBBER,INJECT
243A	4620JJ3006C	STOPPER,DOOR	622B	4810JA3036A	BRACKET,COVER
244A	3651JA1023U	HANDLE ASSEMBLY,FREEZER	623C	4770JA3001A	BAND
244E	5006JJ3016D	CAP,HANDLE	903A	3550JJ0006C	Cover,Lower
262D	4004JA3002A	CLIP	903B	4930JJ2021A	HOLDER,COVER(LOWER)
281A	3550JJ2013C	COVER,HINGE	903D	6500JK1003A	SENSOR
281B	4775JJ2003B	HINGE ASSEMBLY,UPPER	903E	6500JK1004A	SENSOR
281E	5006JJ3008C	CAP,HINGE	B01	1STZJA3004F	SCREW,CUSTOMZIED
282B	4775JJ8002E	HINGE ASSEMBLY,CENTER	S01	1SZZJJ3010A	SCREW,CUSTOMZIED
282C	1PZZJJ3002F	PIN,COMMON	S22	J471-00001J	SCREW,CUSTOMZIED
282E	5006JJ2001F	CAP,HINGE	S24	1SZZJA3011B	SCREW,CUSTOMZIED
282F	3806JL2006F	DECOR,DUCT	S27	4J01424C	SCREW,CUSTOMZIED
282H	5006JJ3004E	CAP,HINGE	S28	1SZZJJ3005E	SCREW,CUSTOMZIED
283D	4774JJ2002A	HINGE,LOWER	S29	4J00415D	SCREW,CUSTOMZIED
283F	4620JJ2007B	STOPPER,DOOR	S31	4000W4A003A	SCREW,CUSTOMZIED
284D	1STZJA3004K	SCREW,CUSTOMZIED	S38	4J00415D	SCREW,CUSTOMZIED



MFL31442102

Augustt2006