

Amana[®]

**Microwave Oven
Service Manual**

LD510

ULD510

LD510S

ULD510S

CAUTION

BEFORE SERVICING THE UNIT, READ THE
SAFETY PRECAUTIONS IN THIS MANUAL.

SAFETY PRECAUTIONS

This device is to be serviced only by properly qualified service personnel.

Consult the service manual for proper service procedures to assure continued safety operation and for precautions to be taken to avoid possible exposure to excessive microwave energy.

PRECAUTIONS TO BE OBSERVED BEFORE AND DURING SERVICING TO AVOID POSSIBLE EXPOSURE TO EXCESSIVE MICROWAVE ENERGY

- A) Do not operate or allow the oven to be operated with the door open.
- B) Make the following safety checks on all ovens to be serviced before activating the magnetron or other microwave source, and make repairs as necessary; (1) interlock operation, (2) proper door closing, (3) seal and sealing surfaces (arcing, wear, and other damage), (4) damage to or loosening of hinges and latches, (5) evidence of dropping or abuse.
- C) Before turning on microwave power for any service test or inspection within the microwave generating compartments, check the magnetron, wave guide or transmission line, and cavity for proper alignment, integrity, and connections.
- D) Any defective or misadjusted components in the interlock, monitor, door seal, and microwave generation and transmission systems shall be repaired, replaced, or adjusted by procedures described in this manual before the oven is released to the owner.
- E) A microwave leakage check should be performed on each oven prior to release to the owner.

CAUTION MICROWAVE RADIATION

DO NOT BECOME EXPOSED TO RADIATION FROM THE MICROWAVE GENERATOR OR OTHER PARTS CONDUCTING MICROWAVE ENERGY.

CONTENTS

(Page)

SAFETY PRECAUTIONS	Inside front cover
SPECIFICATIONS	1-1
CAUTIONS	2-1
INSTALLATIONS	3-1
OPERATING INSTRUCTIONS	4-1
FEATURES.....	4-1
CONTROL PANEL	4-2
OPERATING SEQUENCE	4-3
SCHEMATIC DIAGRAM.....	4-7
CIRCUIT DESCRIPTION.....	4-8
SERVICE INFORMATION	5-1
TOOLS AND MEASURING INSTRUMENTS	5-1
MICROWAVE LEAKAGE TEST.....	5-1
MEASUREMENT OF MICROWAVE POWER OUTPUT	5-3
DISASSEMBLY AND ADJUSTMENT	5-3
INTERLOCK CONTINUITY TEST.....	5-7
COMPONENT TEST PROCEDURE.....	5-8
TROUBLE SHOOTING.....	5-11
EXPLODED VIEW	6-1
REPLACEMENT PARTS LIST	7-1
SCHEMATIC DIAGRAM OF P.C.B.	8-1
PRINTED CIRCUIT BOARD	8-2
PCB PARTS LIST	9-1

SPECIFICATIONS

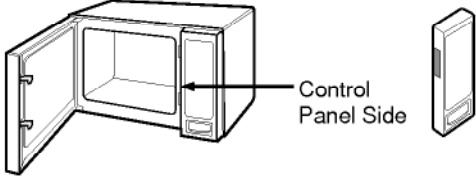
ITEM	DESCRIPTION
MODEL	LD510/ULD510/LD510S/ULD510S
Power Requirement	230 Volts AC 50 Hz 1,350 Watts (6.3 A) Single phase, 3 wire grounded
Power Output	1000 Watts full microwave power (IEC705)
Microwave Frequency	2,450 MHz
Magnetron	2M214 - 39F, 2M218J
Timer	0 ~ 60 min.
Outside Dimensions	530 (W) x 322 (H) x 404(D) mm
Cavity Dimensions	348 (W) x 232 (H) x 373 (D) mm
Net Weight	17 kg (approx.)
Shipping weight	19 kg (approx.)
Control Complement	Microwave Power for Variable Cooking Power level Max ----- Full power throughout the cooking time Med.-High ----- approx. 80% of Full power Medium ----- approx. 60% of Full power Defrost ----- approx. 40% of Full power Low/Warm ----- approx. 20% of Full power
Name Plate Location	
Accessories	Owner's manual Glass tray Rotating Ring
<p>This microwave oven is designed for household use only. It is not recommended for commercial purposes.</p>	

CAUTIONS

Unlike other appliances, the microwave oven is high-voltage and high-current equipment. Though it is free from danger in ordinary use, extreme care should be taken during repair.

- DO NOT operate on a 2-wire extension cord during repair and use.
- NEVER TOUCH any oven components or wiring during operation.
- BEFORE TOUCHING any parts of the oven, always remove the power plug from the outlet.
- For about 30 seconds after the oven stops, an electric charge remains in the high voltage capacitor. When replacing or checking, you must discharge the high voltage capacitor by shorting across the two terminals with an insulated screwdriver.

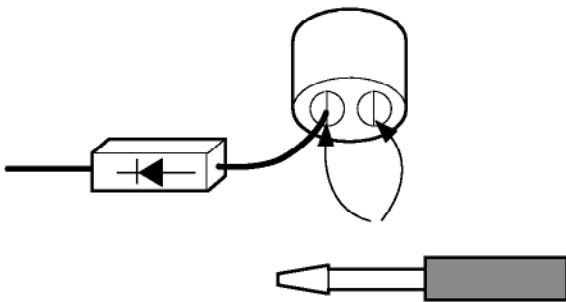

- Remove your watches whenever working close to or replacing the Magnetron.
- DO NOT touch any parts of the control panel circuit. A resulting static electric discharge may damage this P.C.B.
- NEVER operate the oven with no load.
- NEVER injure the door seal and front plate of the oven cavity.
- NEVER put iron tools on the magnetron.
- NEVER put anything into the latch hole and the interlock switches area.

MICROWAVE RADIATION

Personnel should not be exposed to the microwave energy which may radiate from the magnetron or other microwave generating device if it is improperly used or connection. All input and output microwave connections, waveguide, flange and gasket must be secure never operate the device without a microwave energy absorbing load attached. Never look into an open waveguide or antenna while the device is energized.

- Proper operation of the microwave oven requires that the magnetron be assembled to the waveguide and cavity. Never operate the magnetron unless it is properly installed.
- **Be sure that the magnetron gasket is properly installed around the dome of the tube whenever installing the magnetron.**

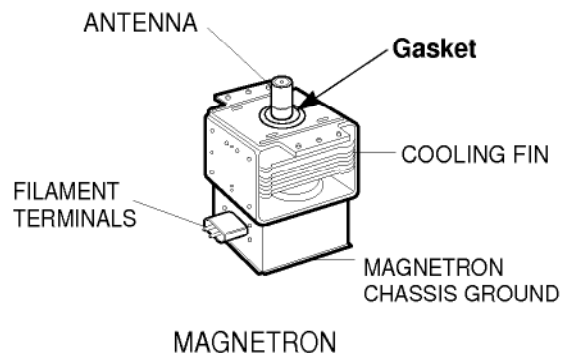

THE OVEN IS TO BE SERVICED ONLY BY PROPERLY QUALIFIED SERVICE PERSONNEL.

INSTALLATIONS

BEFORE YOU BEGIN, READ THE FOLLOWING INSTRUCTIONS COMPLETELY AND CAREFULLY.

INSTALLING

1. Empty the microwave oven and clean inside it with a soft, damp cloth. Check for damage such as misaligned door, damage around the door or dents inside the cavity or on the exterior.
2. Put the oven on a counter, table, or shelf that is strong enough to hold the oven and the food and utensils you put in it. (The control panel side of the oven is the heavy side. Use care when handling.)
3. Do not block the vent and the air intake openings. Blocking vent or air intake openings can cause damage to the oven and poor cooking results. Make sure the microwave oven legs are in place to ensure proper air flow.
4. The oven should not be installed in any area where heat and steam are generated, because they may damage the electronic or mechanical parts of the unit. Do not install the oven next to a conventional surface unit or above a conventional wall oven.
5. Use microwave oven in an ambient temperature less than 104°F(40°C).
6. Place the microwave oven on a sturdy and flat surface at least 10 cm(4 inches) from the wall.
7. Place the microwave oven as far away as possible from TV, RADIO, COMPUTER, etc., to prevent interference.

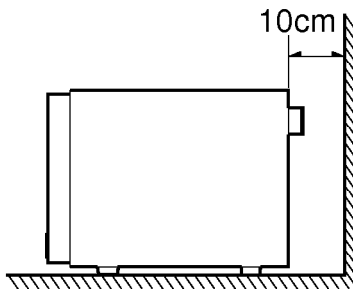

EARTHING INSTRUCTIONS

This microwave oven is designed to be used in a fully earthed condition. It is imperative, therefore, to make sure it is properly earthed before servicing

WARNING- THIS APPLIANCE MUST BE EARTHED

IMPORTANT

The wires in this mains lead are colored in accordance with the following code:

Green-and-yellow:	Earth
Blue:	Neutral
Brown:	Live

As the colors of the wires in the mains lead of this appliance may not correspond with the colored markings identifying the terminals in your plug, proceed as follows.

The wire which is colored **green-and-yellow** must be connected to the terminal in the plug which is marked with the letter **E** or by the **earth symbol** (\perp) or colored **green** or **green-and-yellow**.

The wire which is colored **blue** must be connected to the terminal in the plug which is marked with the letter **N** or colored **black**.

The wire which is colored **brown** must be connected to the terminal in the plug which is marked with the letter **L** or colored **red**.

OPERATING INSTRUCTIONS

FEATURES

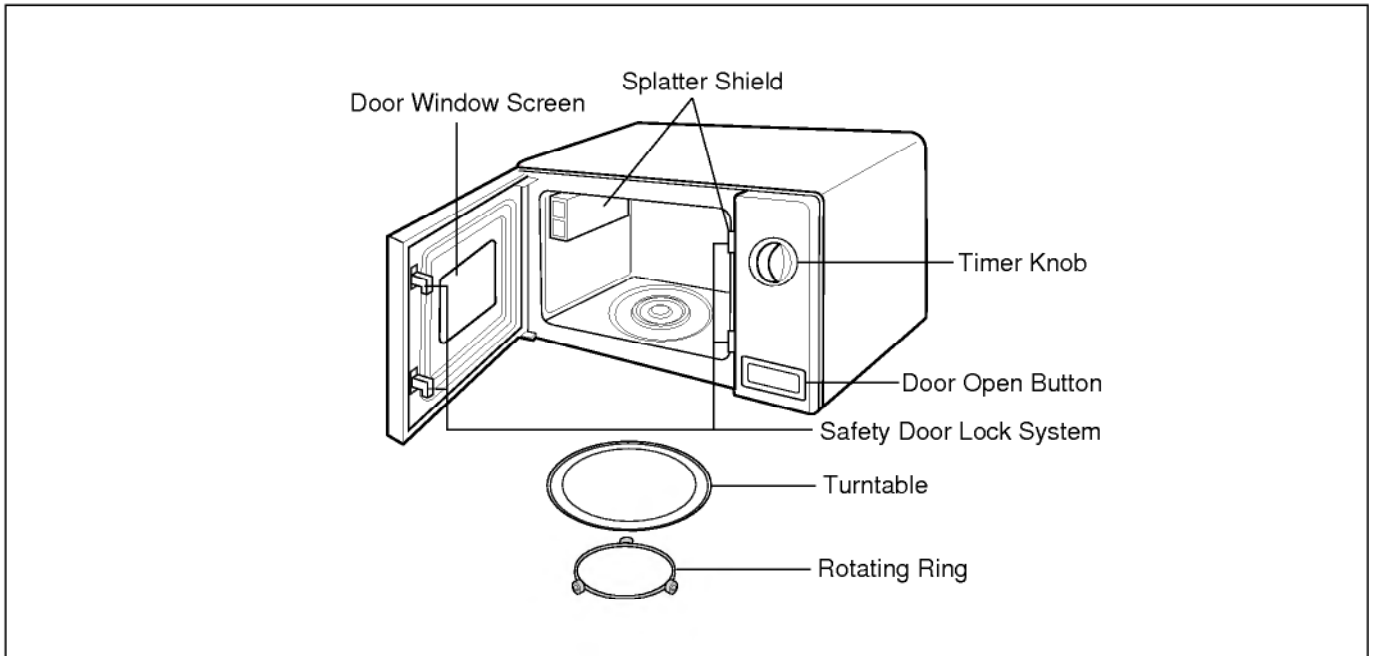

CONTROL PANELS

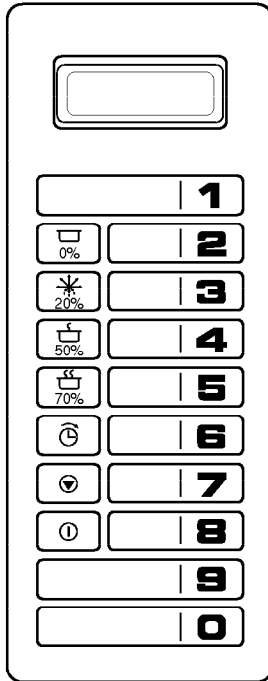

LD510
ULD510
Control Panel

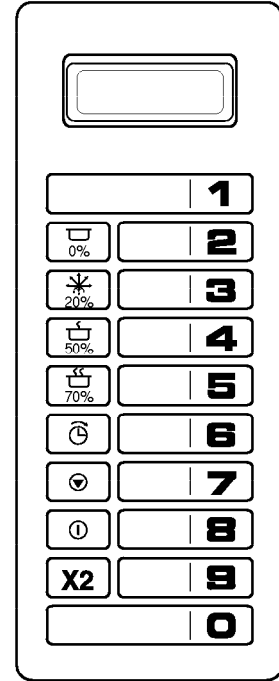

LD510S
ULD510S
Control Panel

Pads

⌚ TIME ENTRY	Use to enter heating time without changing preprogrammed number pads.
1 2 3 4 5 6 7 8 9 0 Pads 1-0	Use to begin heating with preprogrammed times and power levels or to enter times for Manual Time Entry cooking.
☐ * ☐☐ HOLD 0%, DEFROST 20%, MEDUIM 50%, MED-HI 70%	Use to select power level. Oven can heat at full or reduced power. If oven power level is set to 0% oven does not heat for programmed time. If no power level is selected, oven operates at 100% power.
⏏ STOP/RESET	Use to exit programming mode and stop cooking during cooking cycle.
⦿ START	Use to start Manual Time Entry program or restart interrupted cooking cycle. Use to advance to next user option. Use to save times and power levels when programming pads.
X2 (Double Quantity) LD510S ULD510S	Use to extend heating time when more than 1 item is heated.

Display

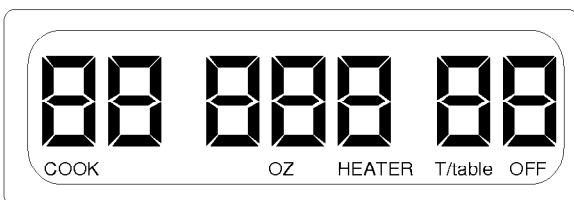

Some items in display can be seen but will not glow.

Cooking Displays

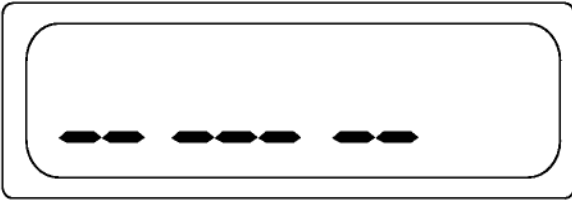

Shows when power is connected to oven. Open and close door to clear.

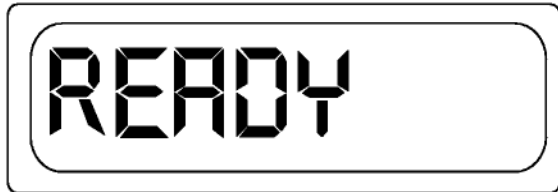

READY shows when oven control will accept entries. Appears after oven door is opened and closed.

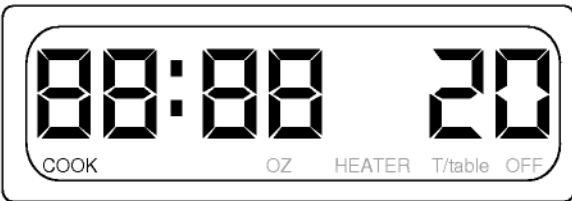

88:88 shows heating time. When more than 1 heating stage is programmed, total time for all stages displays.

COOK shows when oven is operating.

20 indicates the microwave power level used. If power level does not show, oven is heating at 100% power.

Programming Displays



Indicates programming mode. See Programming section of manual for programming procedure.

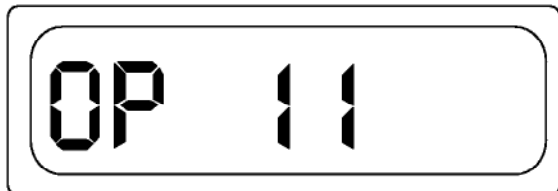

Indicates programming user options mode. See User Options section of manual for programming procedure.

OPERATION



CAUTION

To avoid damaging oven, only heat in microwave oven when turntable is in place.



CAUTION

To avoid fire, do not dry newspapers or clothes in microwave oven.

Interrupting Operation

- Open oven door to interrupt operation. Oven fan continues to operate. Close door and press **START** pad to resume oven operation.
- Press **STOP/RESET** pad to interrupt operation. Display continues to show countdown time. Press **START** pad to resume oven operation and countdown timing.

Canceling Mistakes

- If oven is operating, press **STOP/RESET** pad once to stop oven, then again to clear display.
- If oven door is open and time shows in display, close oven door and press **STOP/RESET** pad to clear display.

Operating Preprogrammed Pads

All models has 10 preprogrammed number pads. Model LD510S, ULD510S has 20 programmable pads (01-20). Instructions are written for factory programmed ovens. Ovens that are reprogrammed can respond below.

1. Open oven door, place food in oven, and close oven door.
 - If pad is not pressed in 30 seconds, open and close oven door again.
2. Press desired number pad.
 - For some models press 2 digits (01-20).
 - Oven operates and time counts down.
3. Oven stops heating and oven signal sounds when heating timing elapses.

X2 (Double Quantity Feature)

Model LD510S, ULD510S only. The X2 pad can add from 10%-100% of additional heating time.

The factory setting is 80%

1. Open oven door, place food in oven, and close oven door.
 - If pad is not pressed in 30 seconds, open and close oven door again.
2. Press X2 pad.

3. Press desired number pad.
 - For some models press 2 digits (01-20).
 - Oven operates and time counts down.
4. Oven stops heating and oven signal sounds when heating timing elapses.

Preprogrammed Times and Cook Level

All preprogrammed pads arrive set at full power.

Pads	Heating Times
1 (01)	10 sec.
2 (02)	20 sec.
3 (03)	30 sec.
4 (04)	45 sec.
5 (05)	1 min.
6 (06)	1:30 min.
7 (07)	2 min.
8 (08)	3 min.
9 (09)	4 min.
0 (10)	5 min.

Pads	Heating Times
(11)	20 sec.
(12)	40 sec.
(13)	1 min.
(14)	1:30 min.
(15)	2 min.
(16)	3 min.
(17)	4 min.
(18)	6 min.
(19)	8 min.
(20)	10 min.

Manual Time Entry

Manual Time Entry feature allows the operator to enter time and power levels, and heat without changing the preprogrammed pads.

1. Open oven door, place food in oven, and close door.
 - Display shows "READY".
 - If pad is not pressed in 30 seconds, open and close oven door again.
2. Press **TIME ENTRY** pad.
 - Display shows "0000".
3. Press number pads to enter desired cooking time.
 - For example, to heat for 2 minutes 30 seconds, press **2**, **3**, and **0** pads.
4. Press desired power level pad to change power level.
 - Display shows current power level if other than 100 percent power.
 - The factory setting is 100%.
5. Press **START** pad.
 - Oven operates and time counts down.
6. Oven stops heating and oven signal sounds when heating timing elapses.

PROGRAMMING

Preprogrammed Number Pads

Oven has 10 preprogrammed number pads. Model LD510S, ULD510S has 20 programmable pads (01-20). Follow instructions below to program heating times and power levels for customized cooking.

1. Open oven door.
 - If door is closed or *STOP/RESET* pad is pressed before finishing programming sequence, oven exits programming mode.
2. Press and hold pad 1 for approximately 5 seconds.
 - After 5 seconds, signal sounds. Display shows "PROGRAM" indicating program mode..
3. Press desired number pad.
 - For some models press 2 digits(01-20).
 - Display shows heating time, "COOK LEVEL" and power level if other than 100 percent power.
4. Press number pads to enter desired cooking time.
 - For example, to heat for 2 minutes 30 seconds, press 2, 3, and 0 pads.
5. Press desired power level pad to change power level.
 - Display shows current power level if other than 100 percent power.
6. Press power level pad to enter desired power level.
 - For example, pressing DEFROST/20% pad is 20 percent power
 - The factory setting is 100%
7. Press *START* pad to save new heating time and power level in oven memory.
8. Press *STOP/RESET* pad or close oven door to exit programming mode.

X2 (Double Quantity Feature)

Model LD510S, ULD510S only. It allows the programmer to change how much heating time is added when X2 pad and then the preprogrammed pad is pressed. The X2 pad can add from 10%-100% of additional heating time.

1. Open oven door.
 - If door is closed or *STOP/RESET* pad is pressed before finishing programming sequence, oven exits programming mode.
2. Press pad hold pad 1 for approximately 5 seconds.
 - After 5 seconds, signal sounds. Display shows "PROGRAM" indicating program mode.
3. Press desired number pad.
 - For some models press 2 digits (01-20) number.
 - Display shows heating time, and programmed number.
4. Press X2 pad.
 - CF:08 shows in display. "CF" represents "cooking factor" and "08" indicates 80%.

5. Press number pad to enter desired cooking factor.
 - For example, pressing 2 pad is 20% (0=100%).
6. Press *START* pad to save new cooking factor in oven memory.
 - Repeat step 3-6 to program additional pads.
7. Press *RESET* pad or close oven door to exit programming mode.

Multiple Heating Stages

Follow instructions below to program oven to perform 3 consecutive heating cycles without interruption.

1. Open oven door.
 - If door is closed or *STOP/RESET* pad is pressed before finishing programming sequence, oven exits programming mode.
2. Press pad 1 for approximately 5 seconds.
 - After 5 seconds, signal sounds.
3. Press desired number pad.
 - Display shows heating time and preprogrammed number.
4. Press number pads to enter desired cooking time.
 - For example, to heat for 2 minutes 30 seconds,
5. Press desired power level pad to change power level.
 - If a power level pad is not pressed, oven defaults to 100% power.
 - For example, pressing MEDIUM 50% pad sets oven to 50% power.
 - Display shows current power level if other than 100 percent power.
6. Press power level 9
 - For example, pressing DEFROST 120% pad is 20 percent power.
 - The factory setting is 100%.
7. Press *TIME ENTRY* pad.
 - Display briefly shows "STAGE 2". Then cook time and power level for stage show in display.
 - Repeat steps 5-8 to create additional stages.
8. Press *START* pad to save new heating time and power level in oven memory.
9. Press *RESET* pad or close oven door to exit programming mode.

User Options

Follow the instructions below to customized the microwave oven's operation. End-of-cycle signal, maximum heating time and other options can be changed to meeting your cooking needs.

1. Open oven door.
 - If door is closed or *STOP/RESET* pad is pressed before finishing programming sequence, oven exits programming mode.
2. Press and hold pad 2 for approximately 5 seconds.
 - After 5 seconds, signal sounds. Display shows "OPTION".
3. Press number pad that matches desired option.
 - "OP" represents optional program mode, first number represents option number and second number represents functions currently selected for option.

4. Press *START* pad to advance to next option. See table for options.
5. Press number pad (0,1-3) to change option.
6. Press *START* pad to save changes.
 - Repeat steps 4-6 to change additional options.
7. Press *STOP/RESET* pad or close oven door to exit programming mode.

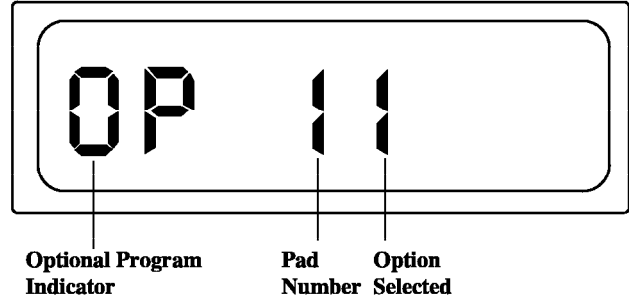

Numbered Pads	Display	Options () = Factory Setting
1 End of Cycle Beep	OP:10 OP:11 OP:12	3 second continuous beep (Continuous Beep until door is opened) 5 beeps bursts until door is opened
2 Speaker Volume	OP:20 OP:21 OP:22 OP:23	Eliminates beep Sets volume to low; 60-70dB Sets volume to medium; 70-80dB (Sets volume to high; 80-90dB)
3 Key Beep	OP:30 OP:31	Prevents signal when pad is pressed. (Allows signal when pad is pressed.)
4 Keyboard Enable Window	OP:40 OP:41	(30 seconds after oven door is opened, keyboard disabled) 2 minutes after oven door is opened, keyboard disabled
5 Add Time during Heating	OP:50 OP:51	(Prevents adding heating time while oven is heating.) Allows adding heating time while oven is heating.
6 Reset Door Open	OP:60 OP:61	Cancels heating time count down after door is opened during cycle. (Allows oven to resume heating time countdown after door is opened during cycle.)
7 Maximum Heating Time	OP:70 OP:71	Allows 10 minutes of heating time. (Allows 60 minutes of heating time.)
8 Manual Operation	OP:80 OP:81	Allows use of preprogrammed pads only. (Allows use of manual time entry and preprogrammed pads.)
9 Double Digit Entry	OP:90 OP:91	Allows 10 (0-9) preprogrammed pads. (Allows 20 (01-20) preprogrammed pads.)

SCHEMATIC DIAGRAM

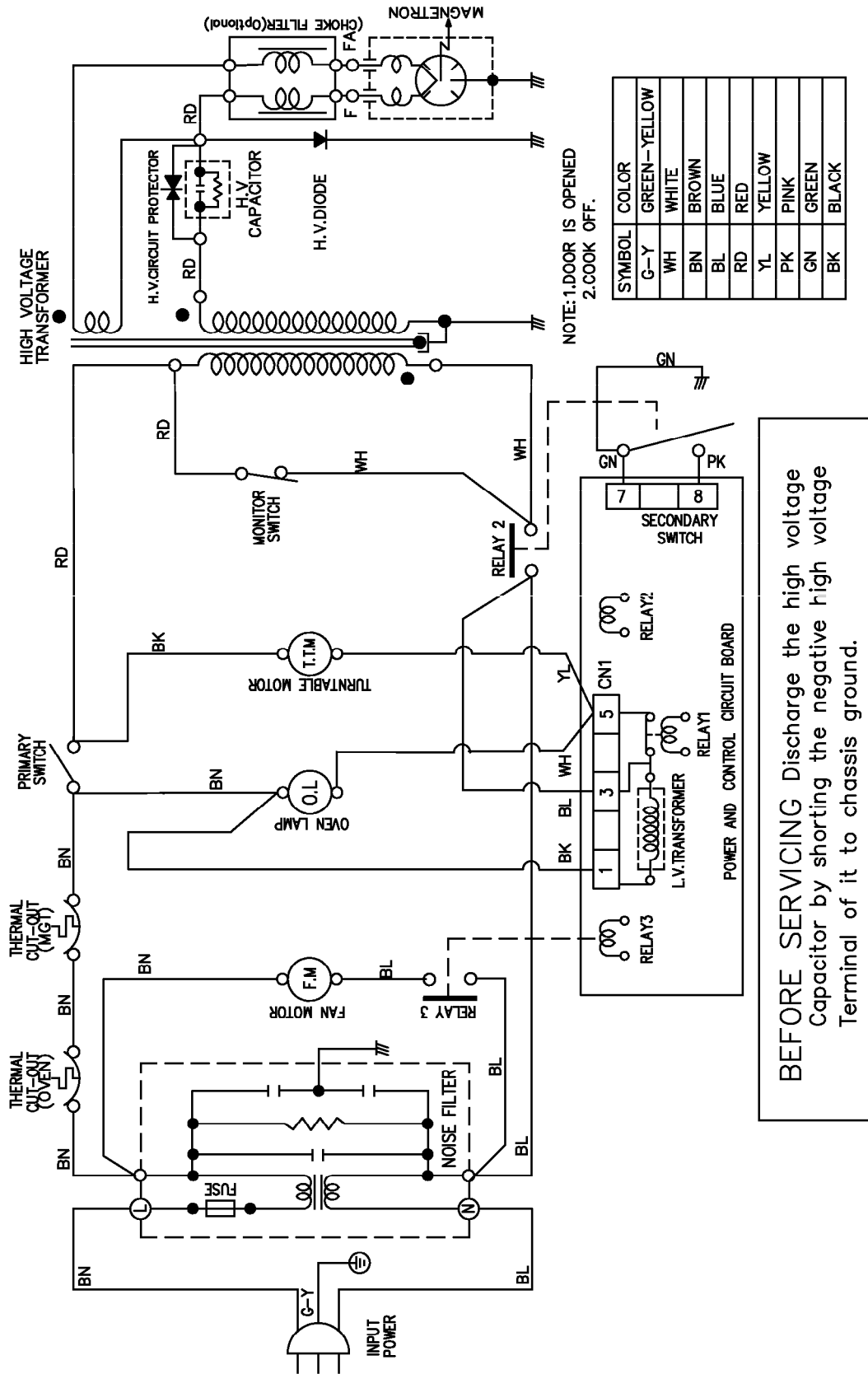

CIRCUIT DESCRIPTION

GENERAL DETAILS

- The low voltage transformer supplies the necessary voltage to the micom controller when power cord is plugged in.
- When the door is closed, the primary switch is ON, the secondary switch is ON, and the monitor switch opens (contact COM and NO).

WHEN SELECTING COOKING POWER LEVEL AND TIME

- The micom controller memorizes the function you set.
- The time you set appears in the display window.
- Each indicator light turns on to indicate that the stage has been set.

WHEN TOUCHING THE START PAD

- The coil of the relay is energized by the micom controller.
- Power input is supplied to the high voltage transformer through the fuse to the primary switch and relay 2.
- Turntable rotates.

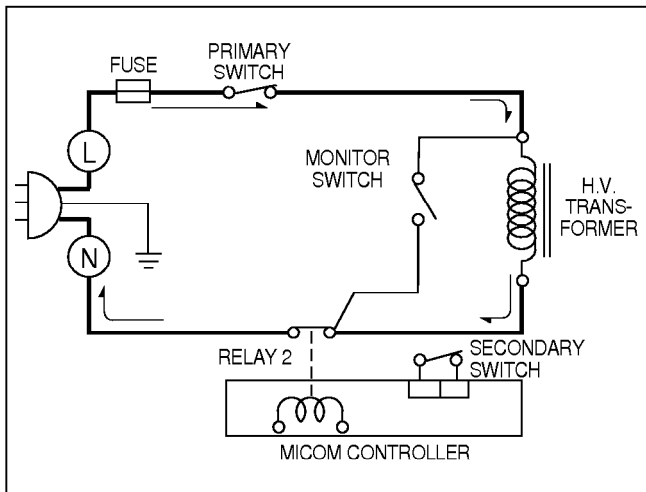

- The fan motor rotates and cools the magnetron by blowing the air (coming from the intake on the baseplate).
- The air is also directed into the oven to exhaust the vapor in the oven through the upper plate.
- Cooking time starts counting down.
- 3.2 volts AC is generated from the filament winding of the high voltage transformer. This 3.2 volts is applied to the magnetron to heat the magnetron filament through two noise-preventing choke coils.

- A high voltage of approximately 2100 volts AC is generated in the secondary of the high voltage transformer which is increased by the action of the high voltage diode and charging of the high voltage capacitor.
- The negative 4,000 Volts DC is applied to the filament of the magnetron.

WHEN THE OVEN IS SET AT ANY LEVEL EXCEPT MAXIMUM.

- The micom controller controls the ON-OFF time of relay 2 by the applied signal to vary the average output power of microwave oven as POWER LEVEL. (refer to page 1-1)

WHEN THE DOOR IS OPENED DURING COOKING

- Both the primary switch and relay 2 are cut off primary winding voltage of the high voltage transformer.
- ON-OFF of relay 2 is coupled electrically with opening and closing of the secondary switch.
- When the door is opened, the secondary switch is opened and when the door is closed, the secondary switch is closed.
- The cooking time stops counting down.
- Relay stops functioning.
- As the door is opened, if the contact of primary switch and relay 2 and/or secondary switch fails to open, the fuse opens due to the large current surge caused by the monitor switch activation, which in turn stops magnetron oscillation.

