

This Owner's Manual is provided and hosted by [Appliance Factory Parts](#).



# LG LDF7811BB Owner's Manual

[Shop genuine replacement parts for LG LDF7811BB](#)



[Find Your LG Dishwasher Parts - Select From 102 Models](#)

----- Manual continues below -----



P/No. : MFL37554801



# DISHWASHER

# SERVICE MANUAL

## NOTE

BEFORE SERVICING THE UNIT, PLEASE READ THIS MANUAL CAREFULLY FOR SAFETY AND CORRECT SERVICES.

MODEL : LDF6810(WW,BB,ST), LDF7810(WW,BB,ST), LDF7811(WW,BB,ST)  
LDS5811(WW,BB,ST), LDF8812(WW,BB,ST)  
LDF6810(WW,BB,ST) / 01, LDF7810(WW,BB,ST) / 01  
LDF7811(WW,BB,ST) / 01, LDS5811(WW,BB,ST) / 01  
LDF6810(WW,BB,ST) / 02, LDS5811(WW,BB,ST) / 02  
LDF8812(WW,BB,ST) / 01

# CONTENTS

---

1. CAUTION .....	4
2. SPECIFICATIONS .....	5
3. WIRING DIAGRAM.....	6
4. FEATURES & TECHNICAL EXPLANATION .....	7
5. PARTS NAME .....	18
6. PROGRAM CHART .....	22
7. HOW TO DISASSEMBLE .....	26
8. TROUBLE SHOOTING METHODS.....	35
A. TROUBLE SHOOTING ACCORDING TO DISPLAYED ERROR MESSAGE.....	35
B. TROUBLE DIAGNOSES AND REPAIR BY SYMPTOM.....	37
9. INSTALLATION INSTRUCTION .....	41
10. EXPLODED VIEW .....	48
11. REPLACEMENT PART LIST .....	59

# CAUTION !

- DISCONNECT POWER CORD BEFORE SERVICING
- RECONNECT ALL GROUNDING DEVICES

## IMPORTANT SAFETY NOTICE !

This service information is intended for individuals possessing adequate backgrounds of electrical, electronic and mechanical experience.

Any attempt to repair this appliance may result in personal injury and property damage.

The manufacturer or seller can not be responsible for the interpretation of this information, nor can it assume any liability in connection with its use.

## 2. SPECIFICATION

---

ITEM	SPECIFICATION
Rated Voltage / Frequency	AC 120V/60Hz
Installation	Built-In
Place Settings	16
Product Dimension(in)	23 7/8" x 25" x 33 7/8"
Product Weight(lbs)	7811, 7810, 8812 series : 115lbs, 5811/6810 series : 110lbs
Door Color	White, Black, Stainless
Tub Material	Stainless Steel
Control	Electronic
Rated Power(Watt)	1,350
Heater Power(Watt)	1,200
Programs	7811, 7810, 5811, 8812 series : 6, 6810 series : 5
Upper Rack Position	7811, 7810, 8812 series : Adjustable, 6810 series : manual
Lower Rack	50% Fold down
Water Consumption (ℓ)	7811,7810 , 6810, 5811 series : 21-30 (Normal) 8812, 7811/01, 7810/01, 6810/01, 5811/01 series : 10-26 (Normal)
Power Consumption(kWh/year)	7811/ 7810 / 6810 / 5811 series : 352-370 8812, 7811/01, 7810/01, 6810/01, 5811/01 series : 285-310
Operating Time (min)	101-135 (Normal)
Fan Dry System	Yes
Delay Start Function	Yes
Auto-Off Power Switch	Yes
Process Monitor	Yes
Wash Level	5
Racks	Nylon Coating
Operating Water Pressure (Bar)	20-120 (140-830kPa)

# 3. WIRING DIAGRAM

## 1. 7811 / 7810 / 6810 serie

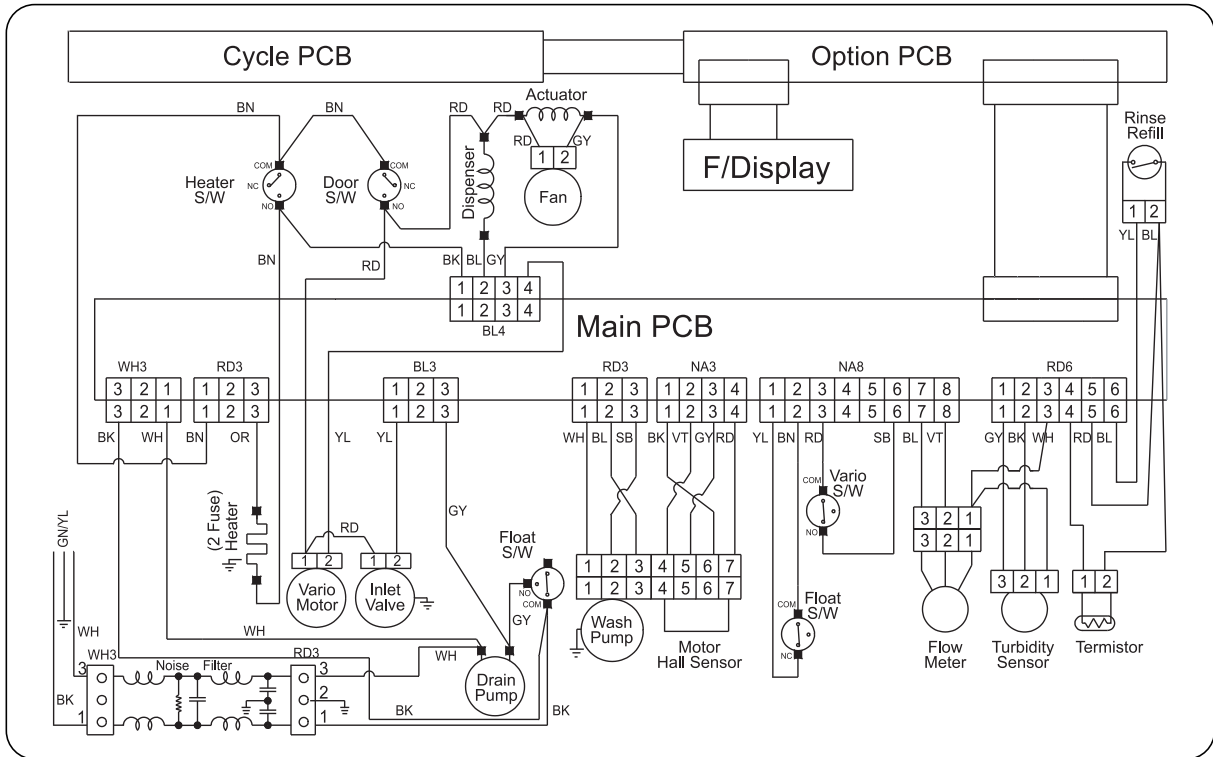

## 2. 8812 serie

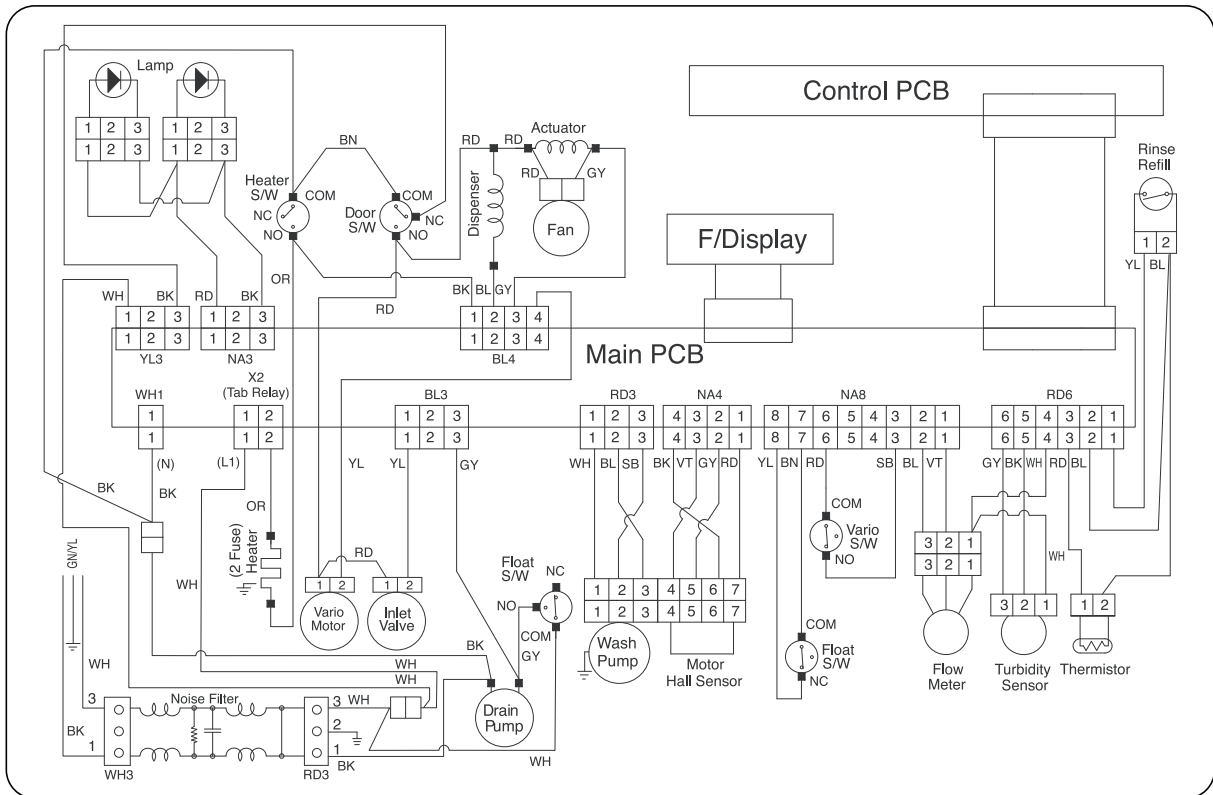

# 4. FEATURES & TECHNICAL EXPLANATION

## 4-1. Product Features

### ■ Ultra Big Capacity

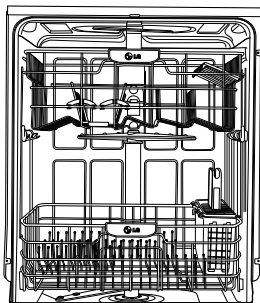

If you raise the Upper Rack, you can load large dishes in the Lower Rack. (Max. 14 in.)

The tall tub provides large dishes loading as well as large capacity.

LG dishwashers let you load oversized items in the Lower and Upper Rack.

### ■ Slim Direct Motor™

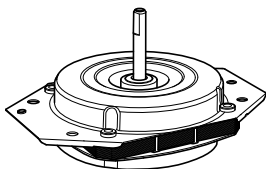

Newly introduced Slim Direct Inverter motor is inverter-controlled. Speed is controlled based on program selection. It also offers high energy efficiency to minimize energy loss.

### ■ Hybrid Drying System

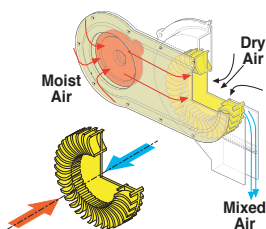

This is one of the best performance solutions for drying dishes because it minimizes venting humid air to the outside of the dishwasher. In addition, this system ensures better drying results compared to the condensing drying system.

### ■ Vario Spray System

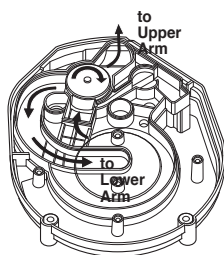

Because of alternating water spray between the Upper and Lower Rack, the water pressure allows superior performance and reduced consumption of water and electricity.

### ■ Self Cleaning Filter

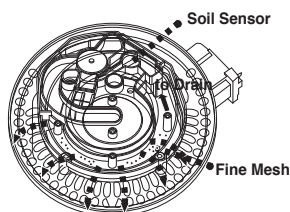

For best wash results, the self-cleaning filter system continuously cleans the water as it circulates. Your LG dishwasher has a self-cleaning filter that grinds food into small particles before it goes down the drain.

## 4-2. Display Panel

### 4-2-1. LDF 7811/7810 Series

- Control panel may vary on some models.

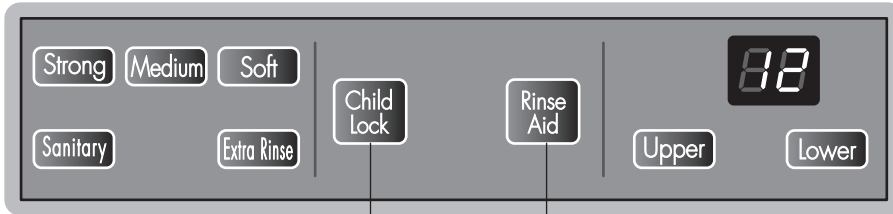

**INDICATOR**

- Child lock: Lamp will turn on when **Child Lock** setting is on.
- Rinse Aid: Refill with Rinse aid when Lamp turns on.

**PROGRAM**

- Press the program that corresponds to your desired wash cycle.

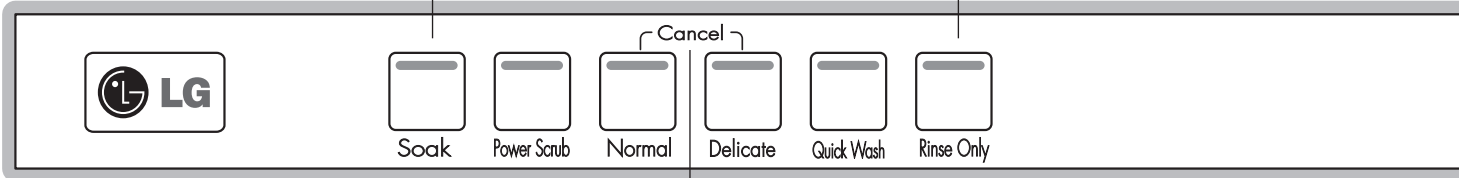

- Soak** This program is for very heavily soiled loads including pots, pans and casserole dishes which may have dry food residue.
- Power Scrub** This program is for very heavily soiled loads
- Normal** This program is for normally soiled everyday loads.
- Delicate** This program is for washing delicate items like glasses.
- Quick Wash** This program is for that quick wash of lightly soiled recently used dishes and cutlery.
- Rinse Only** This program is for very lightly soiled loads.

**CANCEL**

- To cancel a running program, open the door, then press and hold the **Normal** and **Delicate** buttons for 3 seconds.

## SPRAY (INTENSITY)

- Repeated pressing of the Spray button will select **Strong, Medium** or **Soft**.

## DELAY START

- If you want to delay the start of a selected program, press the **Delay Start** button.
- Each press of **Delay Start** will delay the start of the cycle by one hour.
- The delay start time can be adjusted from 1 to 24 hours in one-hour increment.

## POWER

- For operating, press this button first for power on.
- After operating, the power automatically switches off for safety and economy.
- In case of an unusual Power surge or disturbance, the power may be automatically turned off for safety.



## CHILD LOCK

- Lock the control buttons to prevent the settings from being changed.
- To lock/unlock, press **Spray** and **Rinse** buttons simultaneously for 3 seconds with door open.

## SANITARY/ EXTRA RINSE

- Repeated pressing of the Rinse button will select **Sanitary, Extra Rinse** or both.
- If you select the **Sanitary** function, the temperature of Heating Rinse can reach 161° F (72 °C).
- When you select **Extra Rinse**, an additional rinse cycle is added.

## HALF LOAD

- In case of a small load, use the upper or lower rack only to save energy.
- Each press of the **Half Load** button cycles between upper rack only and lower rack only.
- If you don't press **Half Load**, the dishwasher runs normally, i.e., operation of upper and lower spray arm alternating periodically.

## 4-2-2. LDF 5811 Series

### SPRAY (INTENSITY)

- Repeated pressing of the Spray button will select **Strong**, **Medium** or **Soft**.

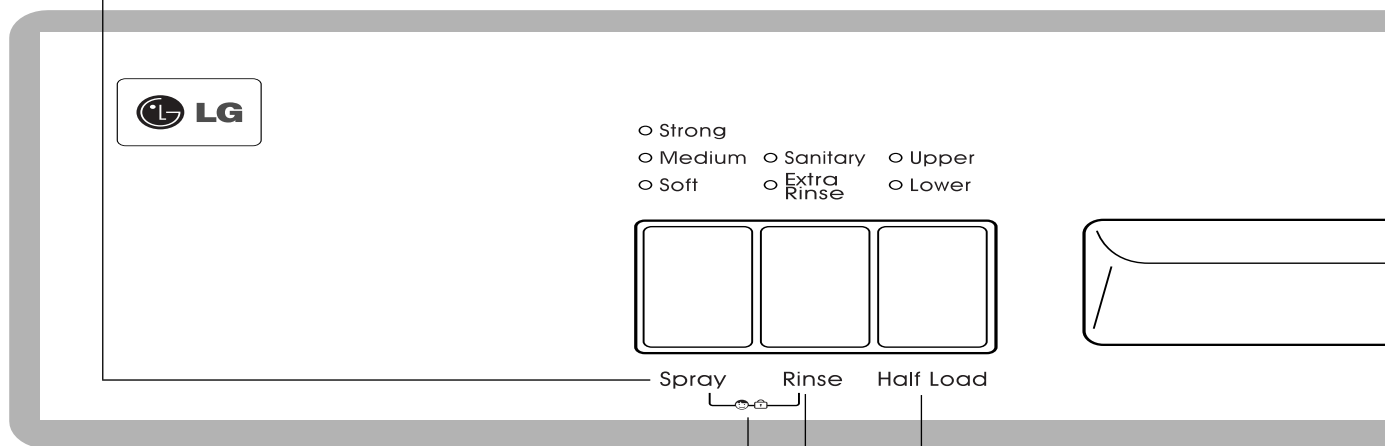

### CHILD LOCK

- Lock the control buttons to prevent the settings from being changed.
- To lock/unlock, press **Spray** and **Rinse** buttons simultaneously for 3 seconds.

### SANITARY/ EXTRA RINSE

- Repeated pressing of the Rinse button will select **Sanitary**, **Extra Rinse** or both.
- If you select the **Sanitary** function, the temperature of Heating Rinse can reach 161°F (72°C).
- When you select **Extra Rinse**, an additional rinse cycle is added.

### HALF LOAD

- In case of a small load, use the upper or lower rack only to save energy.
- Each press of the **Half Load** button cycles between upper rack only and lower rack only.
- If you don't press **Half Load**, the dishwasher runs normally, i.e. operation of upper and lower spray arm alternating periodically.

## INDICATOR

- Child lock: Lamp will turn on when **Child Lock** setting is on.
- Rinse Aid: Refill with Rinse aid when Lamp turns on.

## PROCESSING INDICATOR

- Current program phase is indicated.

## TIME LEFT

- Before starting, the display window shows the running time of the selected program.
- After starting, the display window shows the remaining time.
- If the dishwasher has a trouble, the trouble type is displayed.

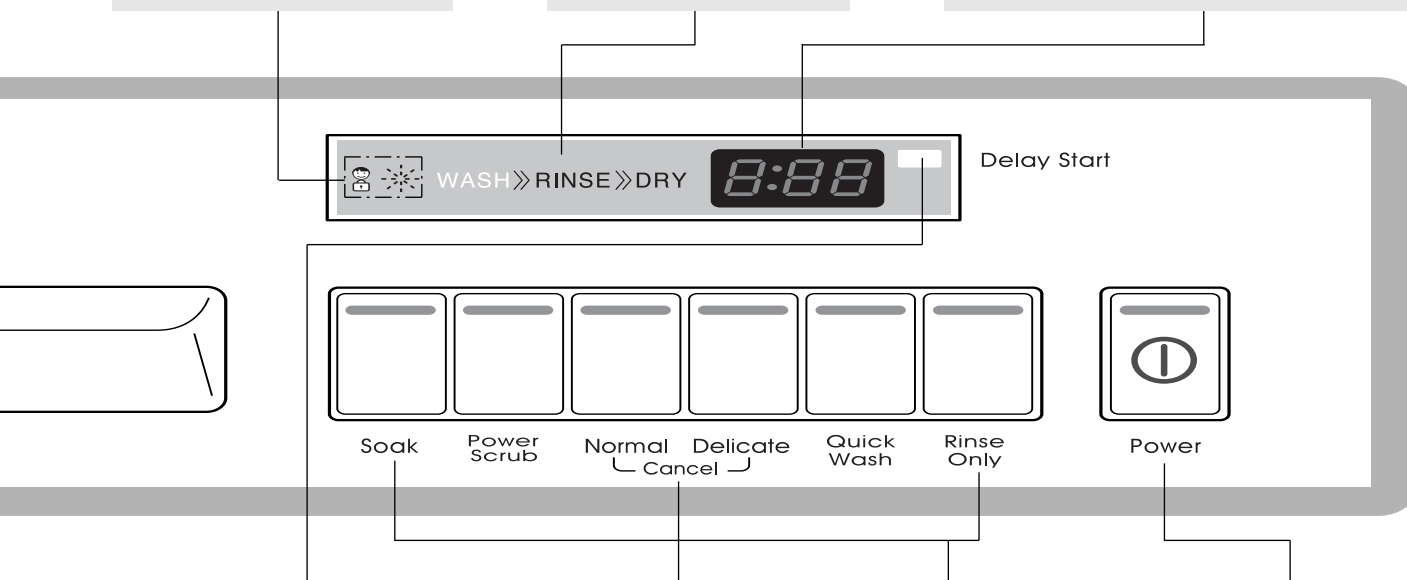

## DELAY START

- If you want to delay the start of a selected program, press the **Delay Start** button.
- Each press of **Delay Start** will delay the start of the cycle by one hour.
- The delay start time can be adjusted from 1 to 12 hours in one-hour increment.

## CANCEL

- To cancel a running program, press and hold the **Normal** and **Delicate** buttons for 3 seconds.

## PROGRAM

- Press the program that corresponds to your desired wash cycle.

## POWER

- For operating, press this button first for power on.
- After operating, the power automatically switches off for safety and economy.
- In case of an unusual Power surge or disturbance, the power may be automatically turned off for safety.

## 4-2-3. LDF 6810 Series

- Control panel may vary on some models.

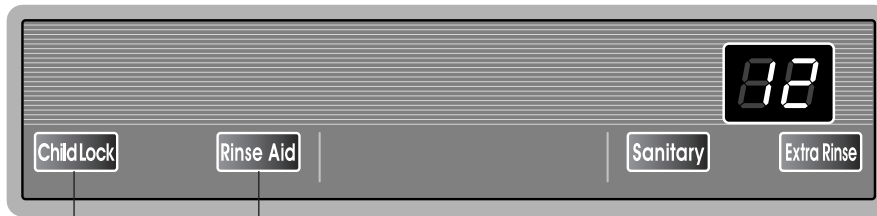

### INDICATOR

- Child lock: Lamp will turn on when **Child Lock** setting is on.
- Rinse Aid: Refill with Rinse aid when Lamp turns on.

### PROGRAM

- Press the program that corresponds to your desired wash cycle.

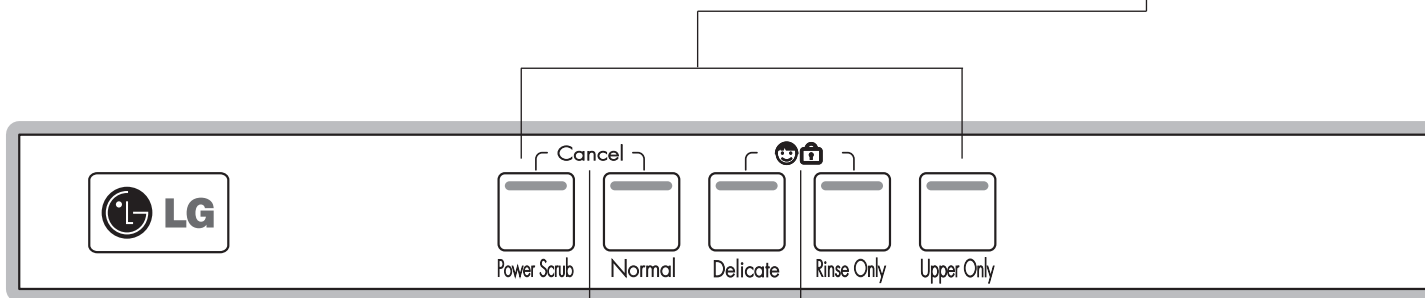

- Power Scrub** This program is for very heavily soiled loads
- Normal** This program is for normally soiled everyday loads.
- Delicate** This program is for washing delicate items like glasses.
- Rinse Only** This program is for very lightly soiled loads.
- Upper Only** This program is to wash some items loaded on the upper rack.

### CANCEL

- To cancel a running program, open the door, then press and hold the **Power Scrub** and **Normal** buttons for 3 seconds.

## DELAY START

- If you want to delay the start of a selected program, press the **Delay Start** button.
- Each press of **Delay Start** will delay the start of the cycle by one hour.
- The delay start time can be adjusted from 1 to 12 hours in one-hour increment.



## CHILD LOCK

- Lock the control buttons to prevent the settings from being changed.
- To lock/unlock, press **Delicate** and **Rinse Only** buttons simultaneously for 3 seconds with door open.

## SANITARY/ EXTRA RINSE

- Repeated pressing of the Rinse button will select **Sanitary**, **Extra Rinse** or both.
- If you select the **Sanitary** function, the temperature of Heating Rinse can reach 161°F (72°C).
- When you select **Extra Rinse**, an additional rinse cycle is added.

## POWER

- For operating, press this button first for power on.
- After operating, the power automatically switches off for safety and economy.
- In case of an unusual Power surge or disturbance, the power may be automatically turned off for safety.

## 4-2-4. LDF 8812 Series

- Control panel may vary on some models.

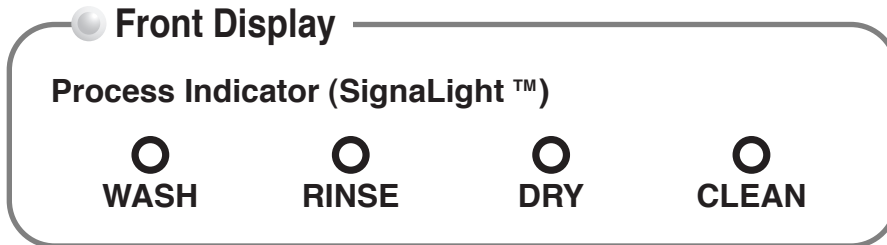

**INDICATOR**

- Child Lock(🔒): Lamp will turn on when **Child Lock** setting is on.
- Rinse Aid(\*): Refill with rinse aid when Lamp turns on.

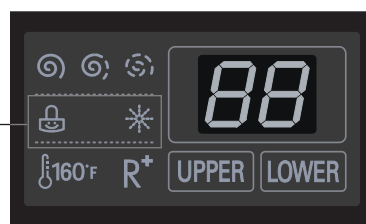

**PROGRAM**

- Press the program that corresponds to your desired wash cycle.

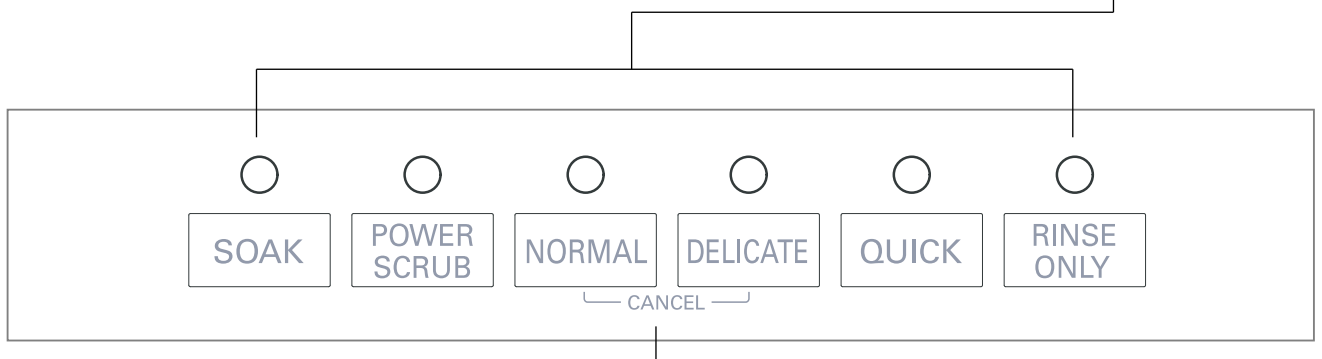

### Soak

This program is for very heavily soiled loads including pots, pans, and casserole dishes, which may have dry food residue.

### Power Scrub

This program is for very heavily soiled loads

### Normal

This program is for normally soiled, everyday loads.

### Delicate

This program is for washing delicate items like glasses.

### Quick

This program is for that quick wash of lightly soiled, recently used dishes and cutlery.

### Rinse Only

This program is for very lightly soiled loads.

**CANCEL**

- To cancel a running program, open the door, then press and hold the **Normal** and **Delicate** buttons for 3 seconds.
- The drain pump will be activated and the cycle will be canceled.

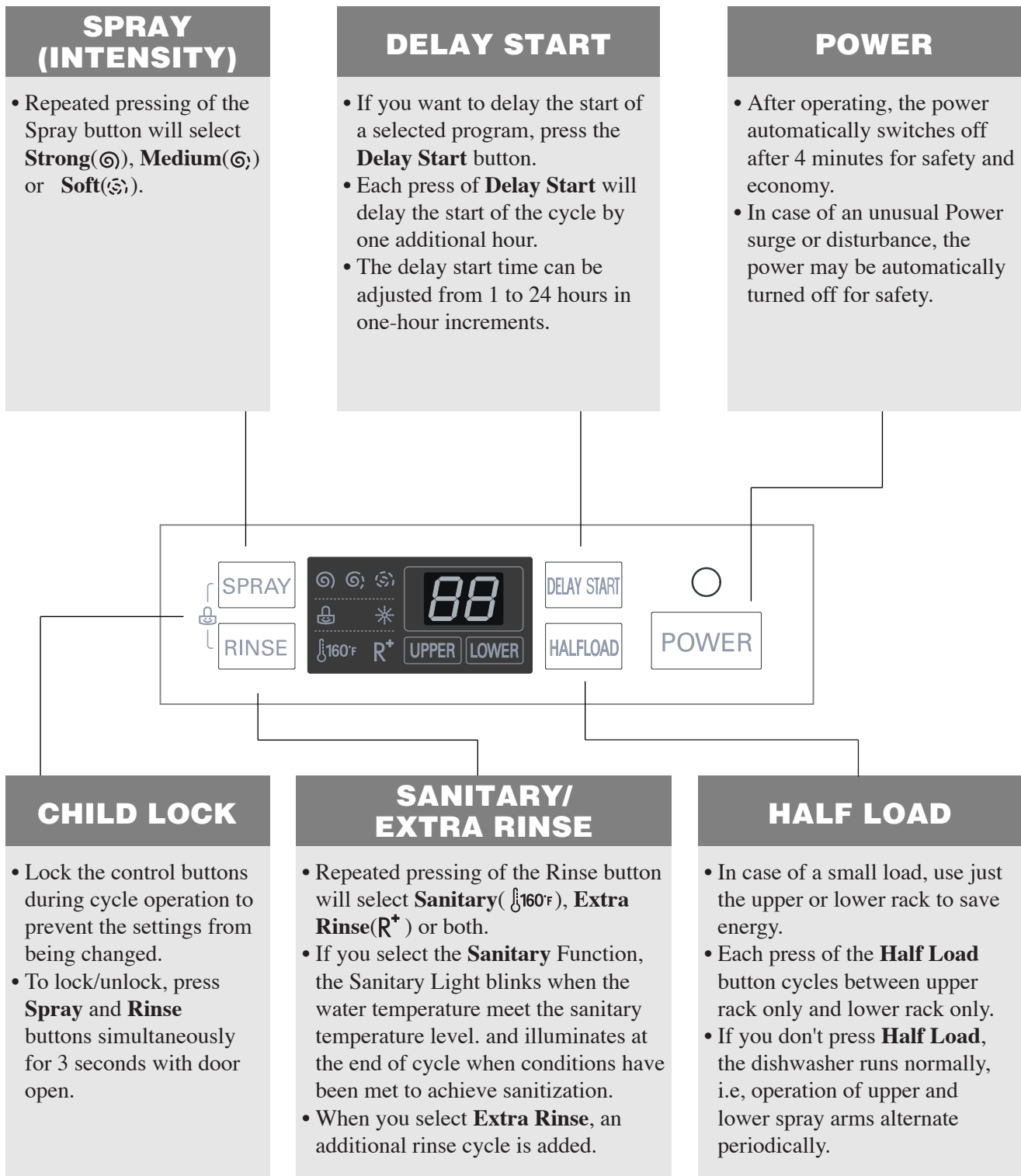

## 4-3. TEST MODE

### 4-3-1. LDF 7811/7810/8812 LDS 5811 Series

#### CHECK PROGRAM

BUTTON	The number of pushing button	Top Display	Front Display	Load and Checking points		Door open/closed
Rinse + Time Delay + POWER SW	1 TIME	3H/U2	n : 3H/U:02	All LEDs are lighting		Both
Soak	1 TIME	11	1 : 11	All LEDs are lighting		Both
Power Scrub	1 TIME	22	2 : 22	All LEDs are lighting		Both
Normal	1 TIME	33	3 : 33	All LEDs are lighting		Both
Delicate	1 TIME	44	4 : 44	All LEDs are lighting		Both
Quick Wash	1 TIME	55	5 : 55	All LEDs are lighting		Both
Rinse Only	1 TIME	66	6 : 66	All LEDs are lighting		Both
Spray	1 TIME	77	7 : 77	Strong/Medium/Soft		Both
Rinse	1 TIME	88	8 : 88	Sanitary-Extra Rinse		Both
Half Load	1 TIME	99	9 : 99	Upper-Lower		Both
Time Delay	1 TIME	31	①Soil Level	Soil Sensor	Delay Start	Both
	2 TIME	32	n : 02	Wash Pump	Child Lock + Rinse Aid	Closed
	3 TIME	33	n : 03	Drain Pump	Wash	Closed
	4 TIME	34	②Frequency	Inlet Valve	Rinse	Both
	5 TIME	35	n : 05	Dispenser	Dry	Closed
	6 TIME	36	n : 06	Heater (for 10 sec)	Wash-Rinse-Dry	Closed
	7 TIME	37	n : 07	Fan	Strong-Soft	Closed
	8 TIME	38	n : 08		Sanitary-Extra	
	9 TIME	39	Temp. (°C)	Thermistor	Upper-Lower	Both
	10 TIME	3A	n : 0A	Lower Nozzle (VARIO)	Soak-Normal	Closed
	11 TIME	3b	n : 0b	Upper Nozzle (VARIO)	Delicate-Rinse Only	Closed
	12 TIME	3c	n : 0c	Wash-Drain-Water Supply	Rinse Aid	Closed
	13 TIME			Auto-Off		Closed

① Normal Water Level : 315

② Pure Water : more than 229

※ Supply water before operating the Test Mode.

## 4-3-2. LDF 6810 Series

### CHECK PROGRAM

BUTTON	The number of pushing button	Top Display	Load and Checking points		Door open/ closed
Upper Only + Time Delay + POWER	1 TIME	3H/U2	All LEDs are lighting		Both
Power Scrub	1 TIME	11	All LEDs are lighting		Both
Normal	1 TIME	22	All LEDs are lighting		Both
Delicate	1 TIME	33	All LEDs are lighting		Both
Rinse Only	1 TIME	44	All LEDs are lighting		Both
Upper Only	1 TIME	55	All LEDs are lighting		Both
					Both
Rinse	1 TIME	66	All LEDs are lighting		Both
					Both
Time Delay	1 TIME	31			Both
	2 TIME	32	Wash Pump		Closed
	3 TIME	33	Drain Pump		Both
	4 TIME	34	Inlet Valve		Closed
	5 TIME	35	Dispenser		Closed
	6 TIME	36	Heater (for 10 sec)		Closed
	7 TIME	37	Fan		Closed
	8 TIME	38		Child Lock + Rinse Aid	
	9 TIME	39	Thermistor	Sanitary-Extra	Both
	10 TIME	3A	Lower Nozzle (VARIO)	Power Scrub + Normal + Delicate	Closed
	11 TIME	3b	Upper Nozzle (VARIO)	Rinse Only + Upper Only	Closed
	12 TIME	3c	Wash-Drain-Water Supply	Rinse Aid	Closed
	13 TIME		Auto-Off		Closed

① Normal Water Level : 295

# 5. PARTS NAME

## 5-1. LDF 7811/7810 Series

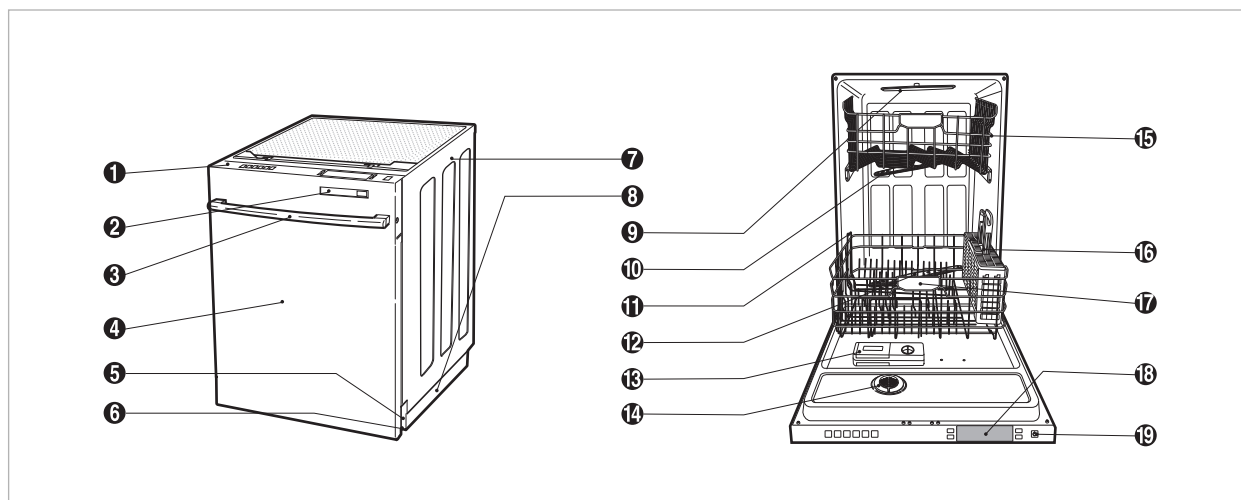

- |                   |                                    |
|-------------------|------------------------------------|
| ❶ Control Panel   | ❶❶ Removable Tines                 |
| ❷ Front Display   | ❶❷ Lower Spray Arm                 |
| ❸ Door Handle     | ❶❸ Detergent & Rinse Aid Dispenser |
| ❹ Front Cover     | ❶❹ Vapor Vent Cover                |
| ❺ Lower Cover     | ❶❺ Upper Rack                      |
| ❻ Leveling Foot   | ❶❻ Cutlery Basket                  |
| ❼ Side Cabinet    | ❶❼ Lower Rack                      |
| ❽ Base            | ❶❽ Top Display                     |
| ❾ Top Spray Arm   | ❶❾ Power Button                    |
| ❿ Upper Spray Arm |                                    |

### Accessories

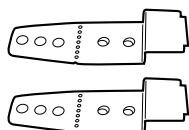

**INSTALL BRACKET**

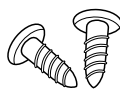

**WOOD SCREW**



**LEVELING KIT**

※ The appearance and specifications may be varied without notice according to localities.

## 5-2. LDF 5811 Series

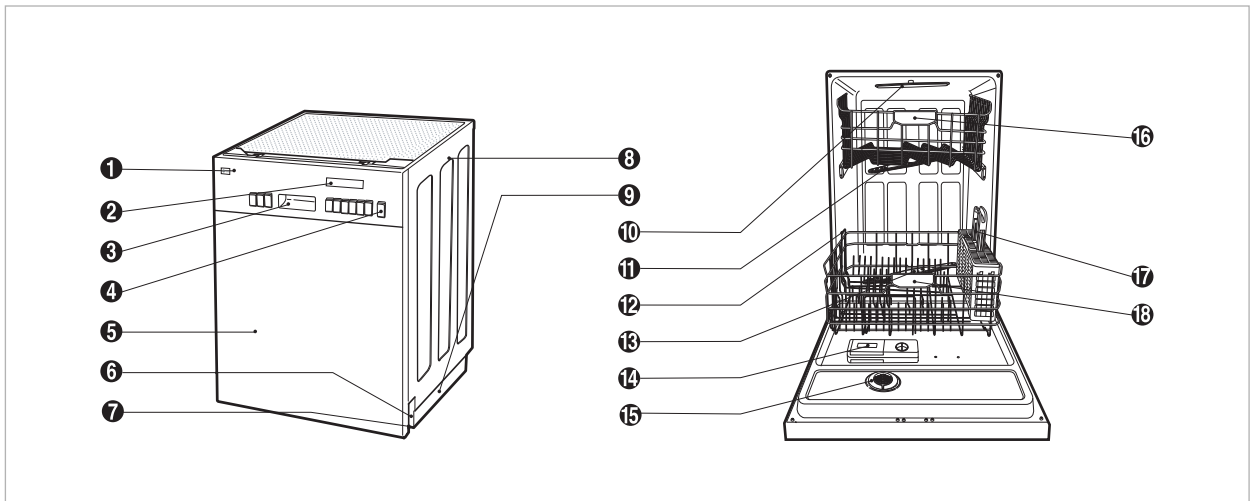

- |                 |                                   |
|-----------------|-----------------------------------|
| ❶ Control Panel | ❷ Top Spray Arm                   |
| ❷ Front Display | ❸ Upper Spray Arm                 |
| ❸ Door Handle   | ❹ Removable Tines                 |
| ❹ Power Button  | ❺ Lower Spray Arm                 |
| ❺ Front Cover   | ❻ Detergent & Rinse Aid Dispenser |
| ❻ Lower Cover   | ❼ Vapor Vent Cover                |
| ❼ Leveling Foot | ❽ Upper Rack                      |
| ❽ Side Cabinet  | ❾ Cutlery Basket                  |
| ❹ Base          | ❿ Lower Rack                      |

### Accessories

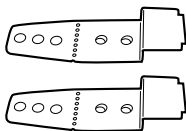

**INSTALL BRACKET**

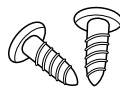

**WOOD SCREW**

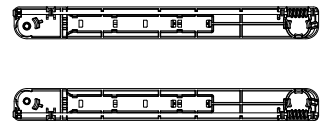

**LEVELING KIT**

※ The appearance and specifications may be varied without notice according to localities.

## 5-3. LDF 6810 Series

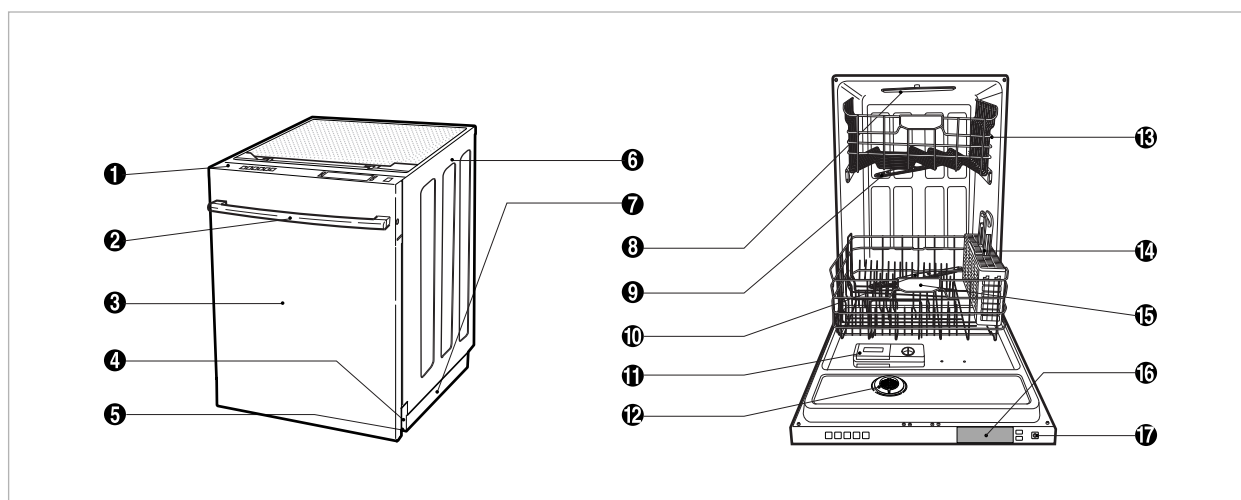

- |                 |        |               |                   |                 |                |               |                 |              |                   |                                   |                    |                  |              |               |                |
|-----------------|--------|---------------|-------------------|-----------------|----------------|---------------|-----------------|--------------|-------------------|-----------------------------------|--------------------|------------------|--------------|---------------|----------------|
| ❶ Control Panel | ❷ Base | ❸ Front Cover | ❹ Upper Spray Arm | ❺ Leveling Foot | ❻ Side Cabinet | ❼ Lower Cover | ❽ Top Spray Arm | ❾ Upper Rack | ❿ Lower Spray Arm | ⓫ Detergent & Rinse Aid Dispenser | ⓬ Vapor Vent Cover | ⓭ Cutlery Basket | ⓮ Lower Rack | ⓯ Top Display | ⓰ Power Button |
|-----------------|--------|---------------|-------------------|-----------------|----------------|---------------|-----------------|--------------|-------------------|-----------------------------------|--------------------|------------------|--------------|---------------|----------------|

### Accessories

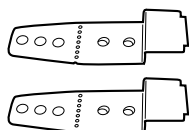

**INSTALL BRACKET**

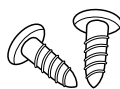

**WOOD SCREW**



**LEVELING KIT**

※ The appearance and specifications may be varied without notice according to localities.

### 5-3. LDF 8812 Series

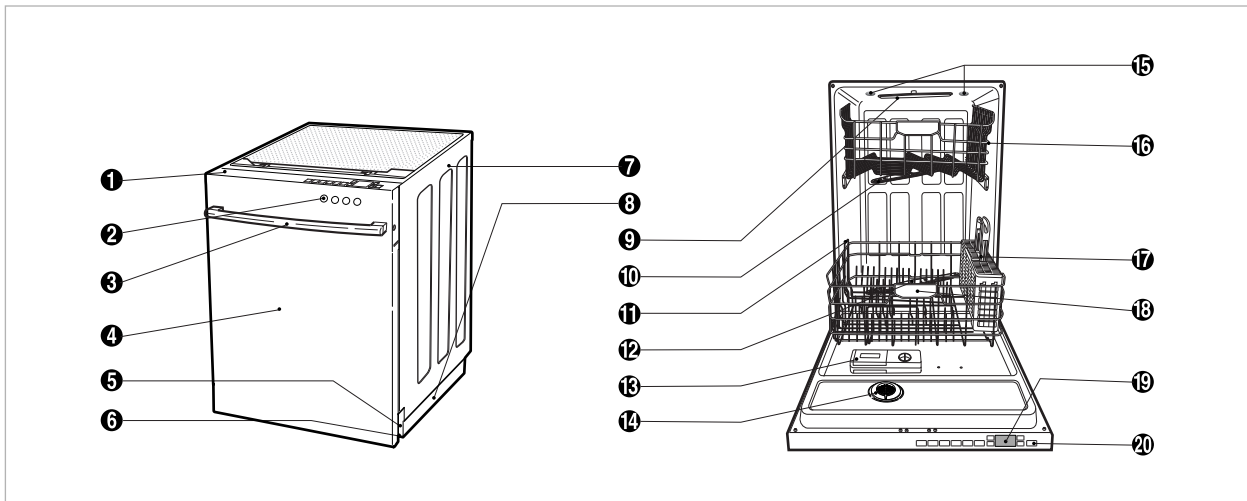

- |  |                                   |
|--|-----------------------------------|
| ① Control Panel                        | ⑪ Removable Tines                 |
| ② Front Display ( <b>SignaLight™</b> ) | ⑫ Lower Spray Arm                 |
| ③ Door Handle                          | ⑬ Detergent & Rinse Aid Dispenser |
| ④ Front Cover                          | ⑭ Vapor Vent Cover                |
| ⑤ Lower Cover                          | ⑮ Tub Lamp ( <b>IllumiTub™</b> )  |
| ⑥ Leveling Foot                        | ⑯ Upper Rack                      |
| ⑦ Side Cabinet                         | ⑰ Cutlery Basket                  |
| ⑧ Base                                 | ⑱ Lower Rack                      |
| ⑨ Top Spray Arm                        | ⑲ Top Display                     |
| ⑩ Upper Spray Arm                      | ⑳ Power Button                    |

\* **IllumiTub™** comes on when the door is opened. It goes off when the door is closed.

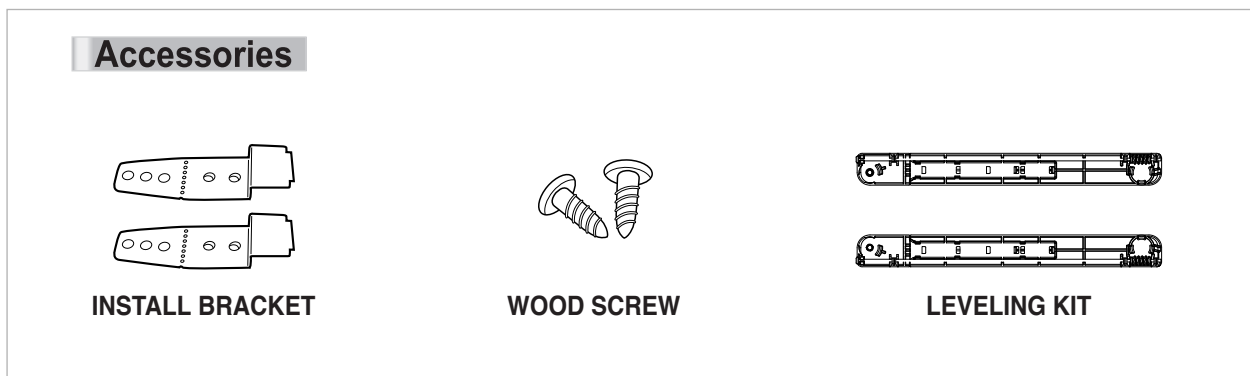

※ The appearance and specifications may be varied without notice according to localities.









# 7. HOW TO DISASSEMBLE

## BEFORE DISASSEMBLING THE DISHWASHER ;

- 1) Remove the cord from electric outlet to avoid electric shock.
- 2) Close the Water Tap (faucet).
- 3) Remove all dishes and items in the dishwasher.
- 4) Remove the Lower Rack and the Upper Rack.
- 5) Remove the inlet hose and drain hose connection to avoid the hose damages.
- 6) Prepare some towels to avoid floor wet by the water left in the dishwasher.

## 7-1. FULL DISASSEMBLE

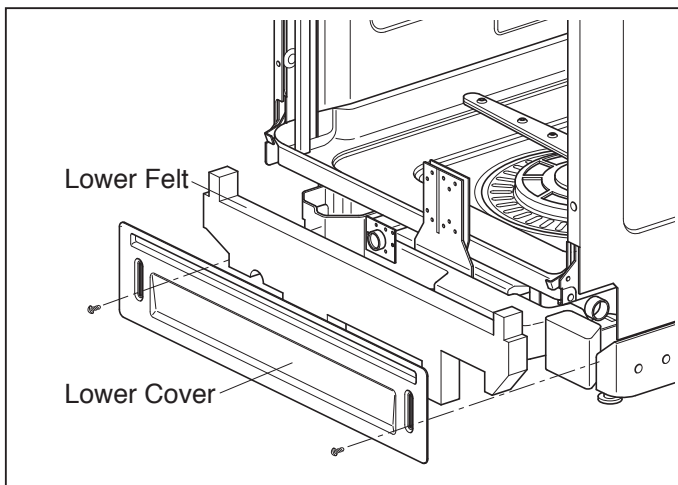

### 1. Lower Cover and Lower Felt

- 1) Remove the front 2 screws.
- 2) Pull the Felt.
- 3) Remove the Inlet Hose and Power Supply Cable.

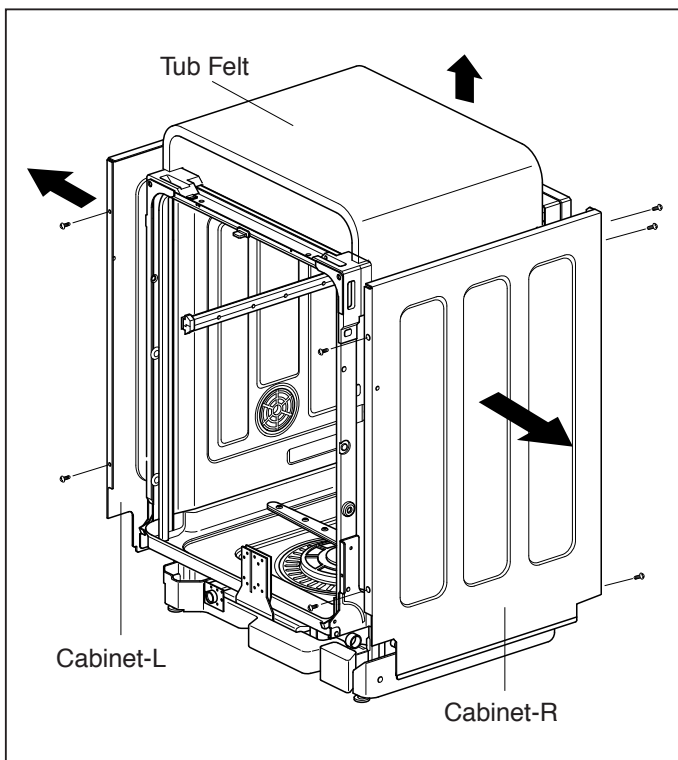

### 2. Cabinet and Tub Felt

- 1) **Cabinet-R**
  - ① Remove front 2 screws.
  - ② Remove rear 3 screws.
- 2) **Cabinet-L**
  - ① Remove front 2 screws.
  - ② Remove rear 3 screws.
- 3) **Tub Felt**
  - ① Pull the Tub Felt.

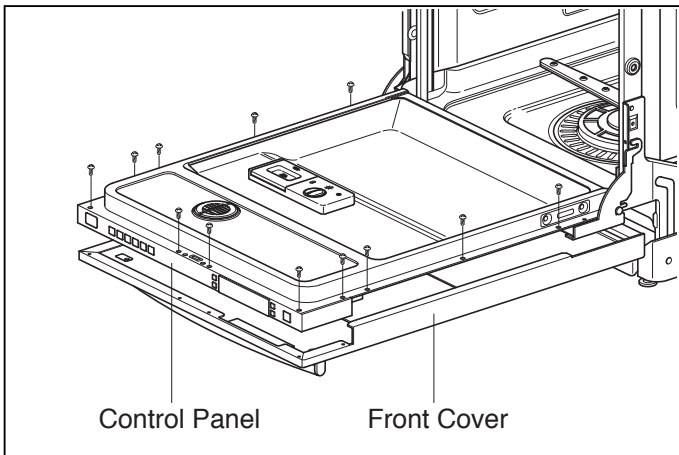

### 3-1. Door Assembly (LDF 6810/7811/7810/8812 Series)

#### 1) Front Cover

- ① Open the door.
- ② Remove 12 screws(stainless).

#### 2) Control Panel Assembly

- ① Remove 2 screws(Stainless).
- ② Remove the wire connections.

Be sure the wiring should not be changed in reassembling

- ③ Remove the Latch assembly.
- ④ Remove the Front Display.
- ⑤ Remove 8 screws for Controller.

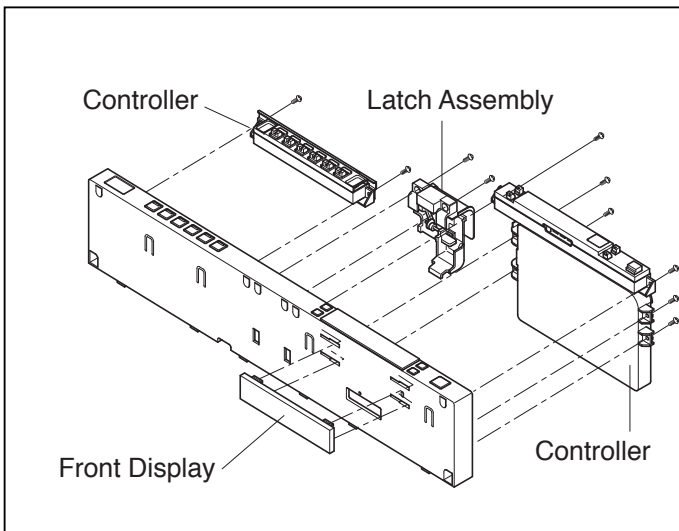
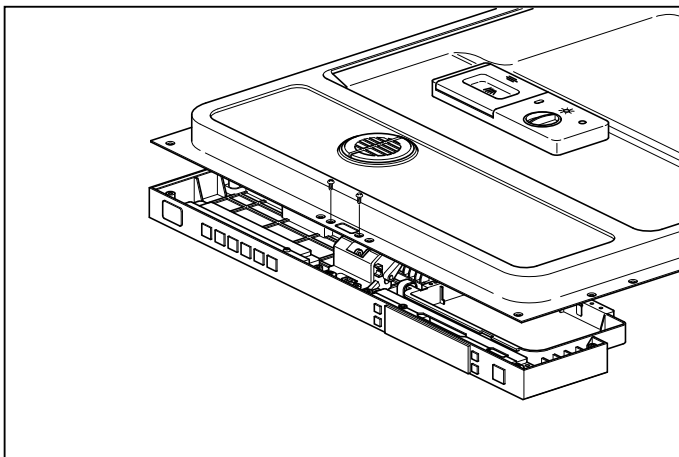

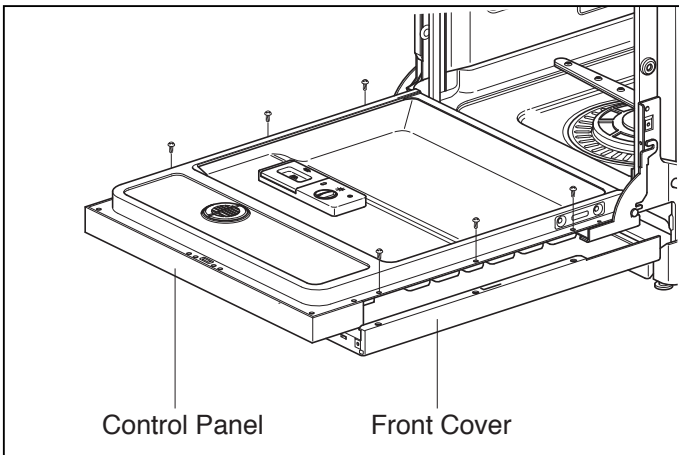

### 3-2. Door Assembly (LDF 5811 Series)

#### 1) Front Cover

- ① Open the door.
- ② Remove 6 screws(Stainless).

#### 2) Control Panel Assembly

- ① Remove 8 screws(Stainless).
- ② Remove the wire connections.

Be sure the wiring should not be changed in reassembling

- ③ Remove the Latch assembly.
- ④ Remove 8 screws for Controller.

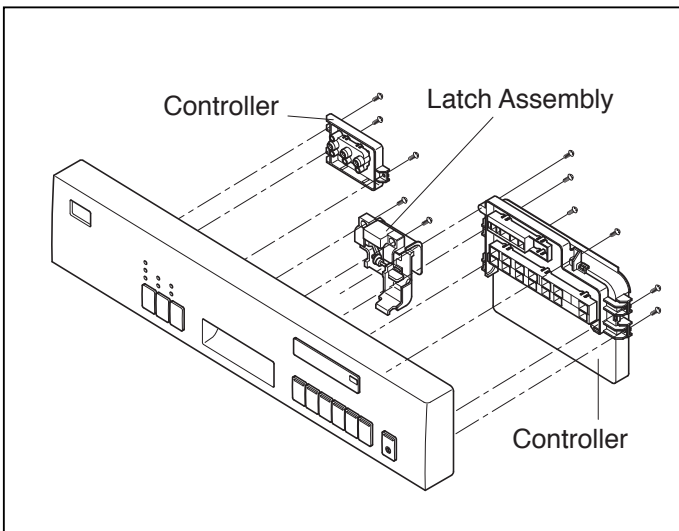
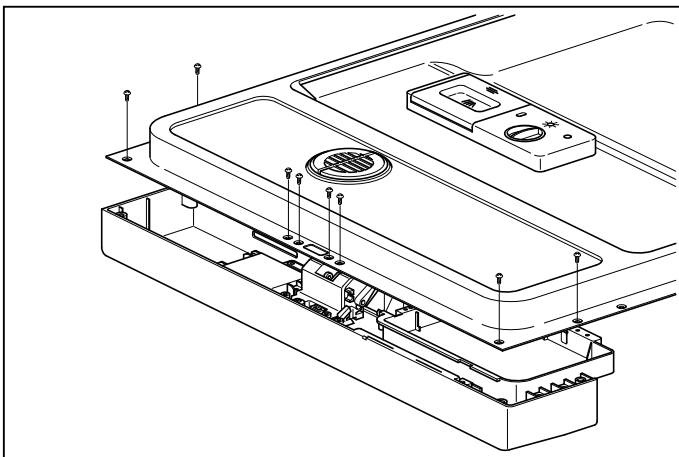

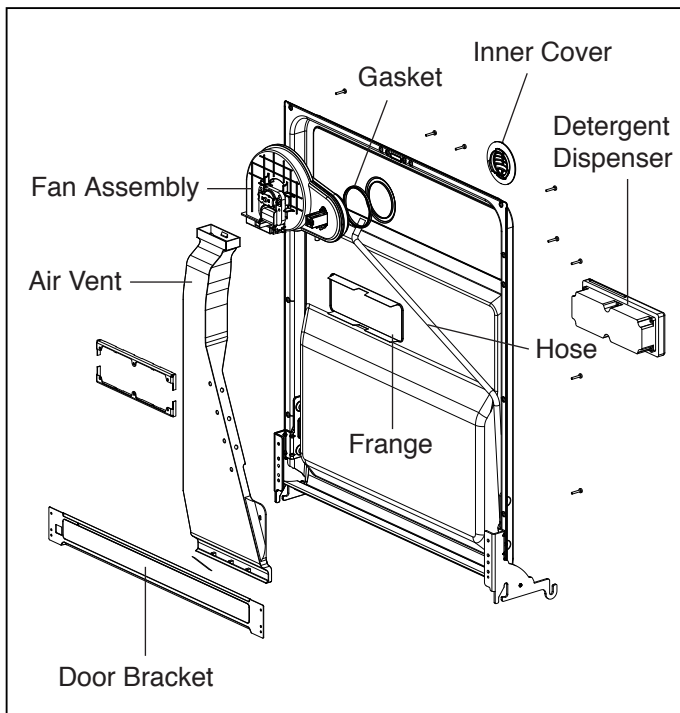

### 3) Fan Assembly

- ① Open the Door.
- ② Remove 4 screws and a earth screw for Door Bracket.
- ③ Remove the wire connector.
- ④ Remove the Air Duct.
- ⑤ Remove Hose with Clamp.(Some Moels)
- ⑥ Turn the Inner Cover counterclockwise.

### 4) Detergent Dispenser

- ① Close the door
- ② Remove the wire connections.
- ③ Remove 6 screws with brackets.
- ④ Push the Detergent slowly pulling up the the Frange by Standard Screwdriver.

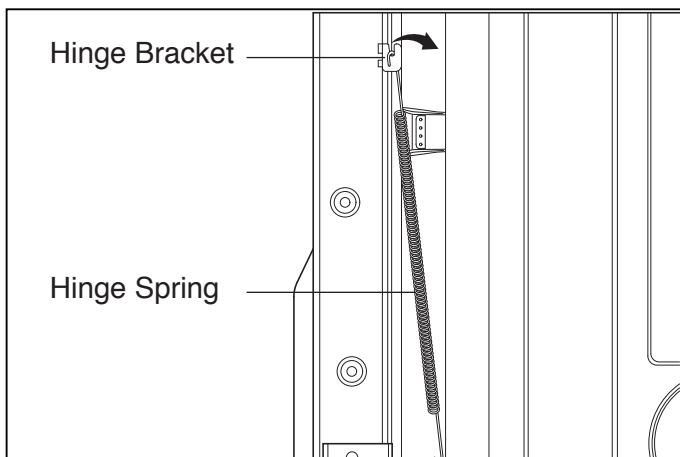

### 5) Door Spring (Right & Left)

- ① Push the Spring upwards and take it off from the Hinge Bracket.
- Be careful not to be injured by the sharpedge of Tub.
- ② Take off the Hinge Link from the Hinge.

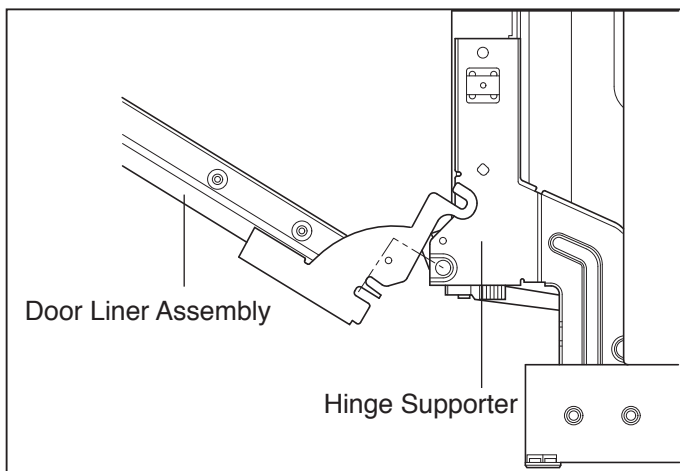

### 6) Door Liner

- ① Open the door.
- ② Pull the Door Liner and take it off from the Hinge Supporter.

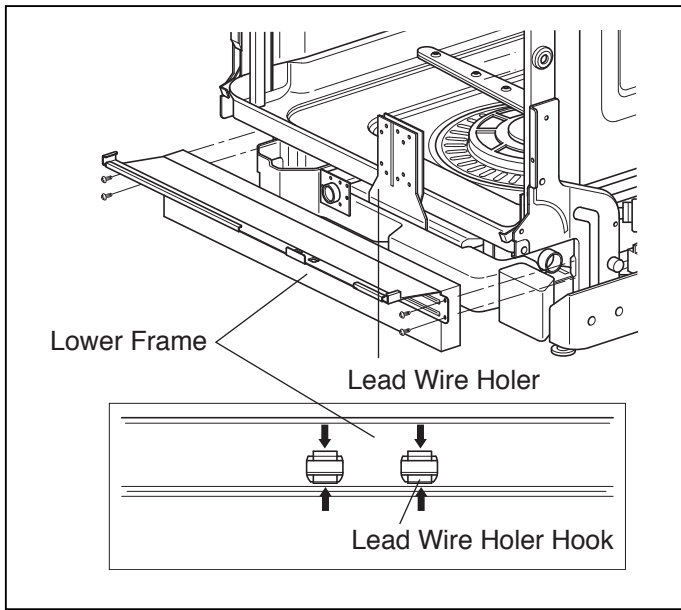

#### 4. Lower Frame

- 1) Press the holder hook as shown in figure.
- 2) Remove 4 screws.

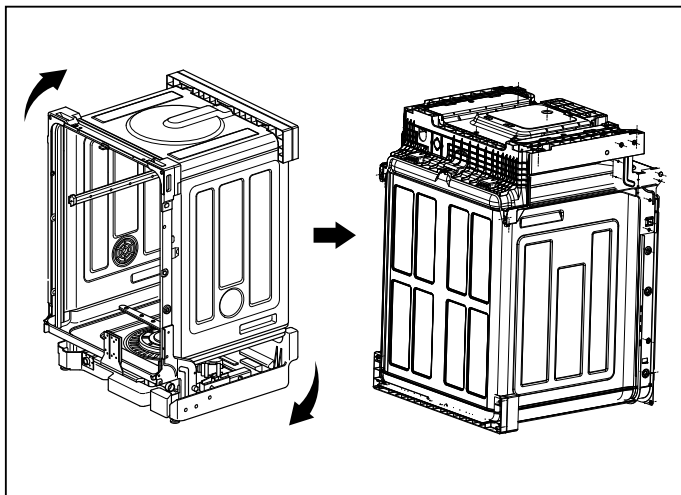

#### 5. Put the Dishwasher upside down.

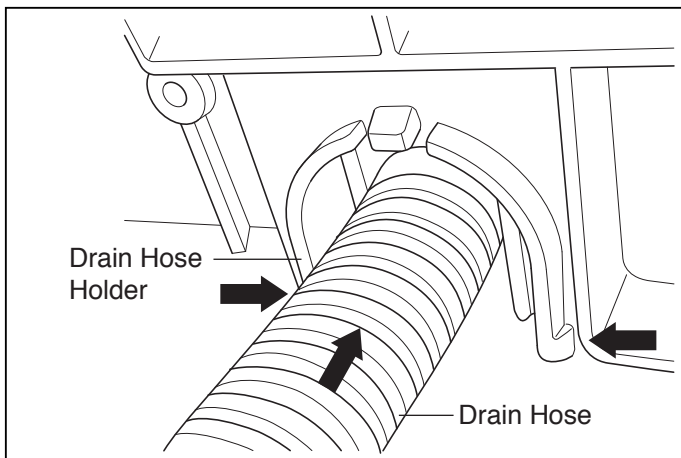

#### 6. Drain Hose Holder

- 1) Press the holder hook as shown in figure.
- 2) Pull the Drain Hose and remove the Drain Hose Holder.

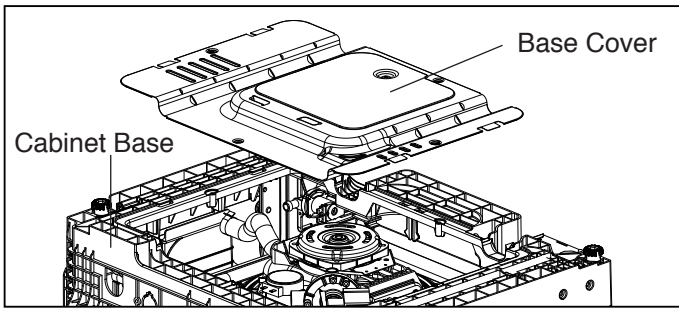

## 7. Base Cover

- 1) Remove 2 screws.
- 2) Pull the Base Cover out.

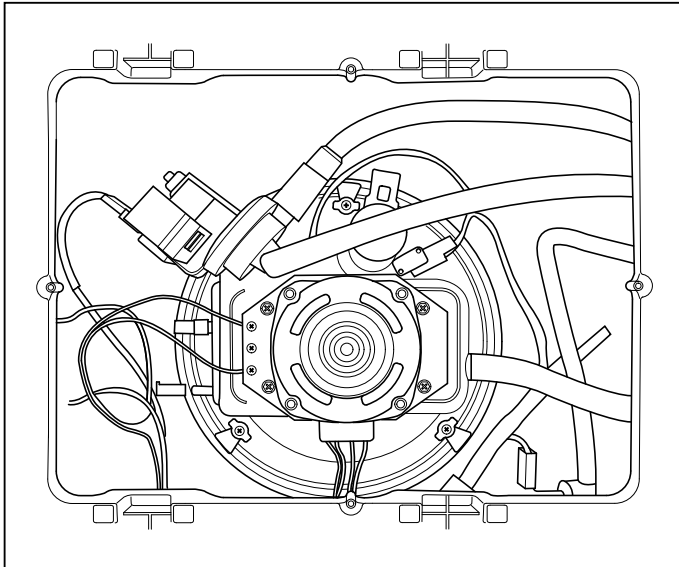

## 8. Harness & Hose Assembly

- 1) Remove the wiring connections.
- 2) Remove the Hose connections from Sump Assembly.

You can see the information of Wiring Diagram at the back of Lower Cover.

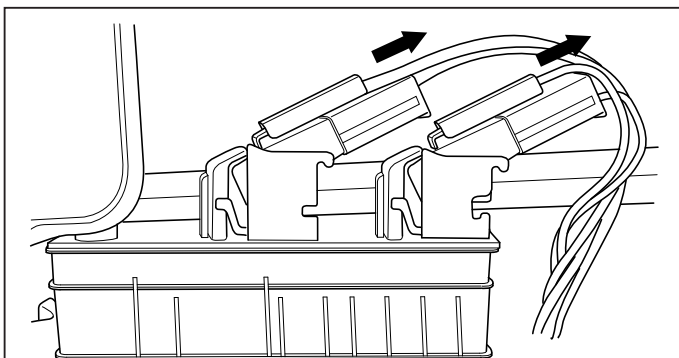
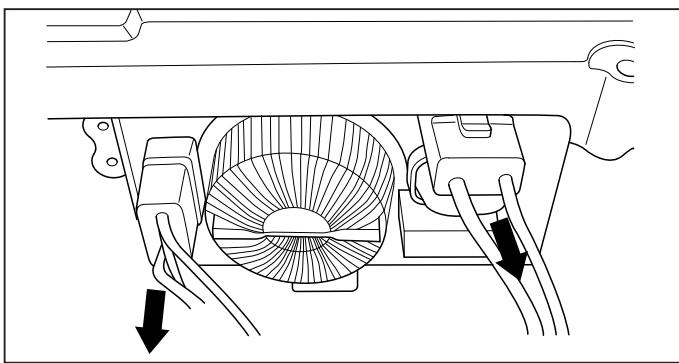

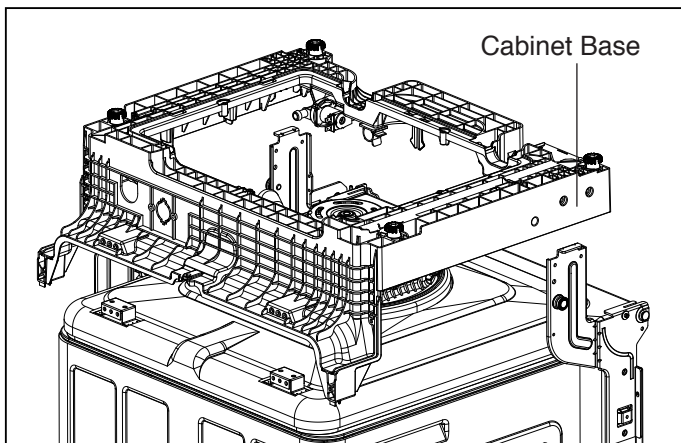

## 9. Cabinet Base

- 1) Remove 8 screws.
- 2) Lift it upward.

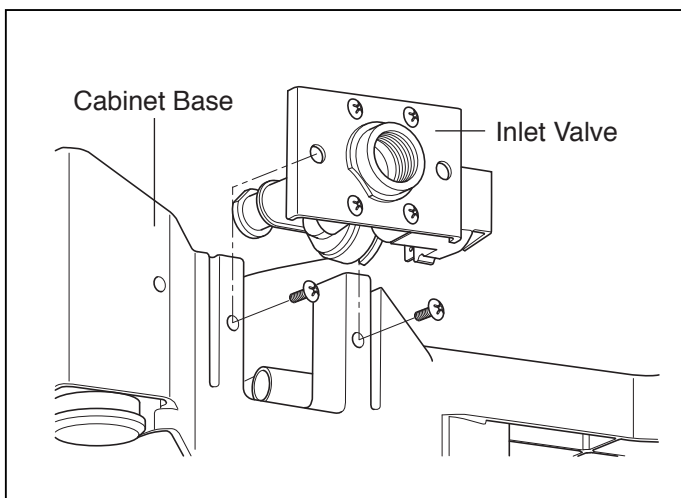

## 10. Inlet Valve

- 1) You can disassemble the Inlet Valve by removing the 2 screws.

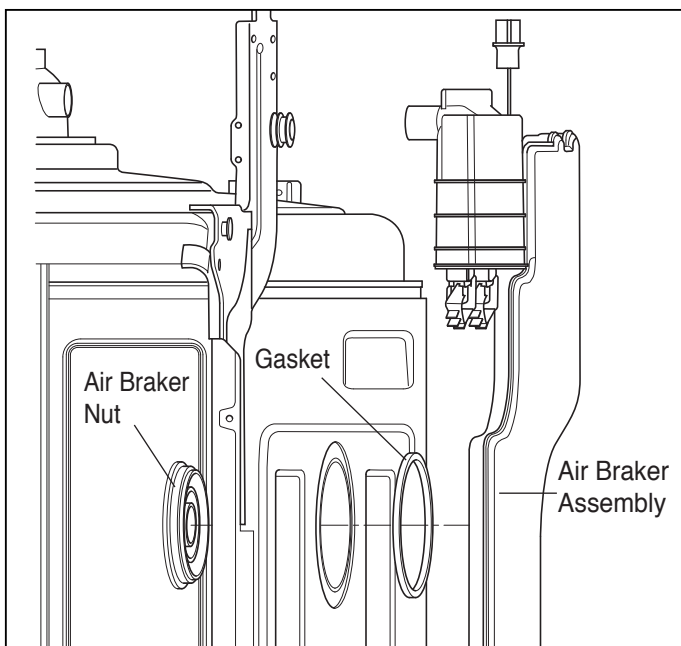

## 11. Air Braker Assembly

- 1) Disconnect the 3 hoses assembly.
- 2) Turn the Air Braker Nut counterclockwise.

Be careful the o-ring should not be lost.

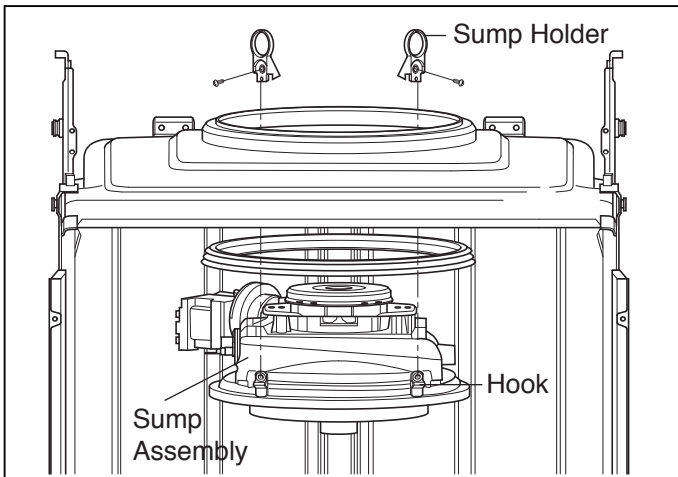

## 12. Sump Assembly

- ① Remove 2 screws.
- ② Remove the Sump Holder and push the Sump Assembly down with pulling aside Hook.

Be careful not to drop the Sump Assembly to the bottom.

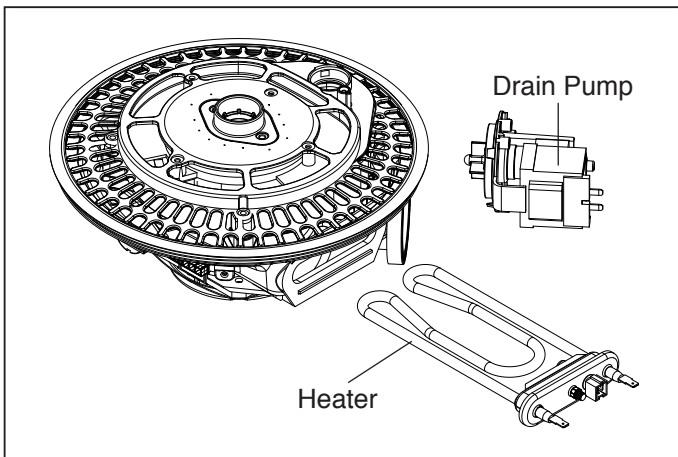

### 1) Heater & Drain Motor

- ① Pull the Heater out of the Sump after releasing the nut.
- ② Remove 3 screws.

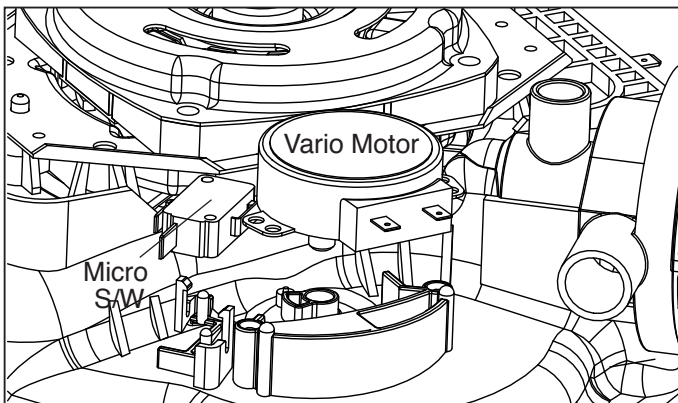

### 2) Vario Motor

- ① Remove 2 screws for Vario Motor.
- ② Pull the Vario Motor and Micro S/W.

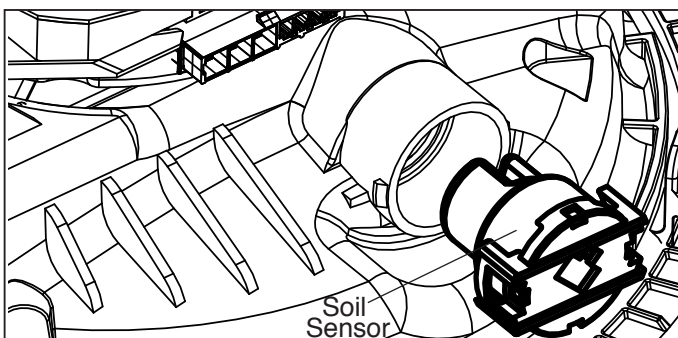

### 3) Soil Sensor

- ① Pull the Soil Sensor.

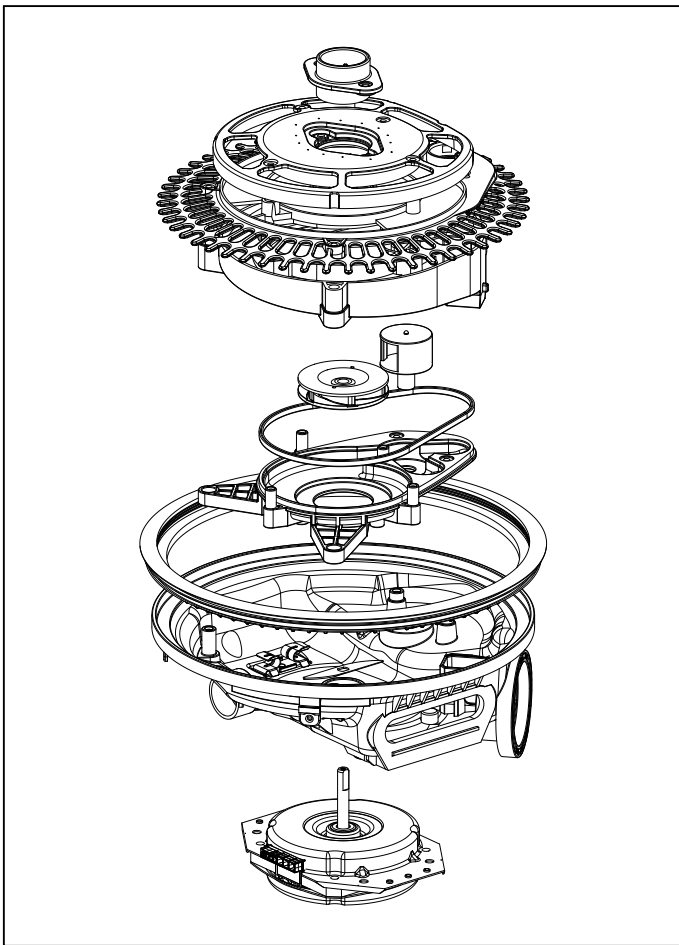

When you reassemble the Sump Assembly, be careful not to kink, tear and take off the seals.

### 13. Holder Supporter, Tub Packing and Hinge Supporter Assembly.

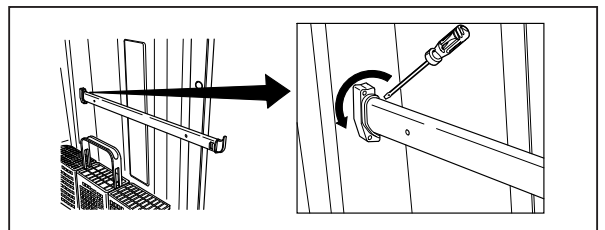

Rotate the screwdriver, after slide it into the gap between Stopper Roller and Rail Roller.

#### LDF 7811/7810/5811/6810 Series

You must take off Stopper Roller(F117) by – screwdriver to change the Rail Assembly. (Stopper Roller could be broken while you are taking off. So you should be careful not to be hurt and have extra stopper rollers ready at servicing at all times)

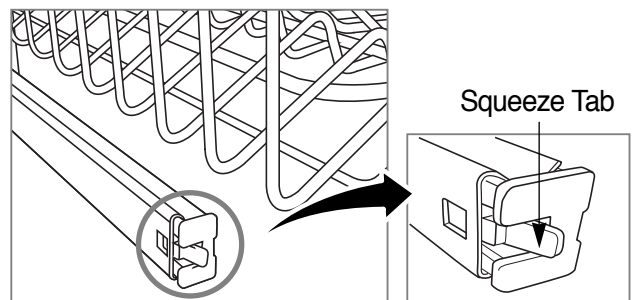
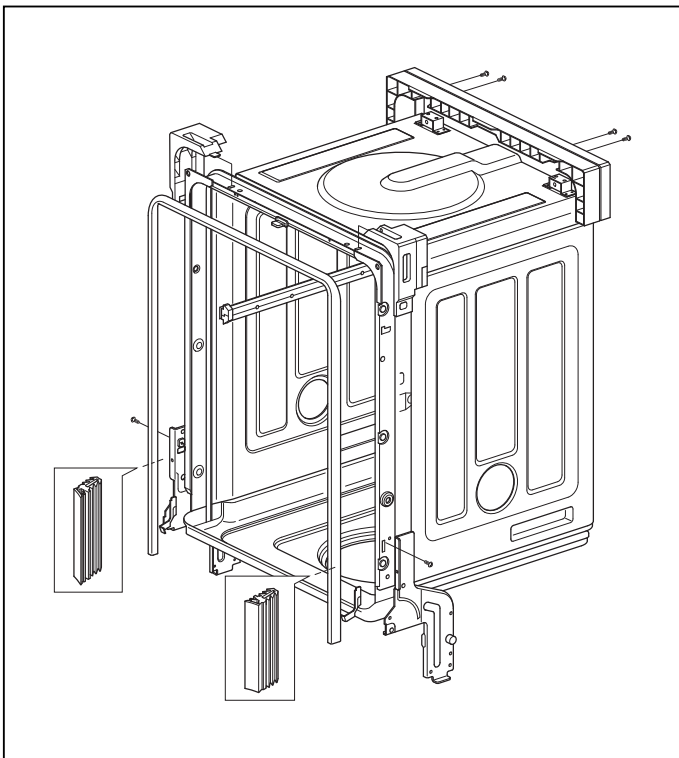







#### LDF 8812 Series

1. Pull the upper rack out until it stops.
2. Squeeze the tab of the stopper and pull out. Be careful the upper rack does not fall off the rail while pulling out the stopper.
3. Pull the upper rack out of the slides.

# 8.TROUBLE SHOOTING METHODS

## A. TROUBLE SHOOTING ACCORDING TO DISPLAYED ERROR MESSAGE

ERROR MESSAGE	POSSIBLE CAUSE FOR ERROR OCCURRENCE	REMEDY
<p><b>INLET ERROR</b></p>  <p>displayed</p> <p><b>Condition</b> Not reached to the normal water level in spite of 10 min. water supply</p>	<ul style="list-style-type: none"> <li>• The Water Supply Tap is closed.</li> <li>• The Water Supply is shut off.</li> <li>• The Inlet Hose is kinked.</li> <li>• The Water Pressure is very low. (below 10 psi)</li> <li>• Inlet Valve is OK?</li> <li>• The filter of Inlet Valve is clogged by impure water.</li> <li>• The Hall sensor is OK?</li> <li>• The Impeller of Air Guide is bound.</li> </ul>	<ul style="list-style-type: none"> <li>• Take action on Water Supply device.</li> <li>• Measure the electric resistance of Inlet Valve. (950-1300 Ω)</li> <li>• Clean the filter of Inlet Valve.</li> <li>• Check the frequency of Inlet Water by the Test Mode.</li> <li>• Replace the Air Braker.</li> </ul>
<p><b>DRAIN ERROR</b></p>  <p>displayed</p> <p><b>Condition</b> Not fully drained out in spite of 5 min. drain operation</p>	<ul style="list-style-type: none"> <li>• The Drain Hose kinked or blocked.</li> <li>• Wiring connection is OK?</li> <li>• The drain outlet of sump is blocked.</li> <li>• The Drain Pump/Motor or circuit is troubled.</li> </ul>	<ul style="list-style-type: none"> <li>• Remove the cause of kink or block.</li> <li>• Check the wiring connection.</li> <li>• Measure the electric resistance of Drain Motor. (20-40 Ω)</li> <li>• Replace the Drain Motor or repair the Circuit.</li> </ul>
<p><b>LEAKAGE ERROR</b></p>  <p>displayed</p> <p><b>Condition</b> The excessive RPM of Washing Motor happened during Wash cycle due to water leakage.</p>	<ul style="list-style-type: none"> <li>• Water leakage in Hose connections.</li> <li>• Water is leaked by damages.</li> <li>• The Motor Water Seal leakage of Sump assembly.</li> <li>• The height of Drain Hose connection (sink-Drain Hose) is not over 20".</li> <li>• Impeller of the Washing Pump is worn away.</li> </ul>	<ul style="list-style-type: none"> <li>• Replace the connections of Hose.</li> <li>• Check the point of damages and repair or replace the related parts.</li> <li>• Read the Installation Instructions (page 9) and fix it to the recommended Height.</li> <li>• Replace the Impeller of the Washing Pump.</li> </ul>

ERROR MESSAGE	POSSIBLE CAUSE FOR ERROR OCCURRENCE	REMEDY
<p><b>EXCESS ERROR</b></p>  <p>displayed</p> <p><b>Condition</b></p> <p>Excessive water is supplied than normal water level.(Automatically drain Pump operated.)</p>	<ul style="list-style-type: none"> <li>• The Inlet Valve is troubled.</li> <li>• The Controller is troubled.</li> </ul>	<ul style="list-style-type: none"> <li>• Replace the Inlet Valve.</li> <li>• Repair or replace the Controller.</li> </ul>
<p><b>THERMAL ERROR</b></p>  <p>displayed</p> <p><b>Condition</b></p> <p>The resistance of thermistor not normally out put.</p>	<ul style="list-style-type: none"> <li>• The Inlet Water Temperature is very high. (over 194 °F)</li> <li>• Wiring connection is OK?</li> <li>• The Thermistor is OK?</li> </ul>	<p>Check the temperature. (Test Mode)</p> <p>1) If the temperature is displayed,</p> <ul style="list-style-type: none"> <li>① adjust the Inlet Water Temperature to 120 °F.</li> </ul> <p>2) If the temperature is not displayed,</p> <ul style="list-style-type: none"> <li>① check the wiring connection.</li> <li>② check the electric resistance of Thermistor. (11~14k <math>\Omega</math> at 77 °F)</li> <li>③ Replace the PCB.</li> </ul>
<p><b>MOTOR ERROR</b></p>  <p>displayed</p> <p><b>Condition</b></p> <p>The Motor is working abnormally.</p>	<ul style="list-style-type: none"> <li>• Wiring connection is OK?</li> <li>• The Impeller of Washing Pump is locked.</li> <li>• The rotor of Washing Motor is locked.</li> <li>• The Blade is locked.</li> </ul>	<ul style="list-style-type: none"> <li>• Check the wiring connection.</li> <li>• Replace the cause of restriction.</li> <li>• Replace the Washing Motor.</li> <li>• Replace the PCB.</li> </ul>

## B. TROUBLE DIAGNOSES AND REPAIR BY SYMPTOM

No Power on when the power button pressed.

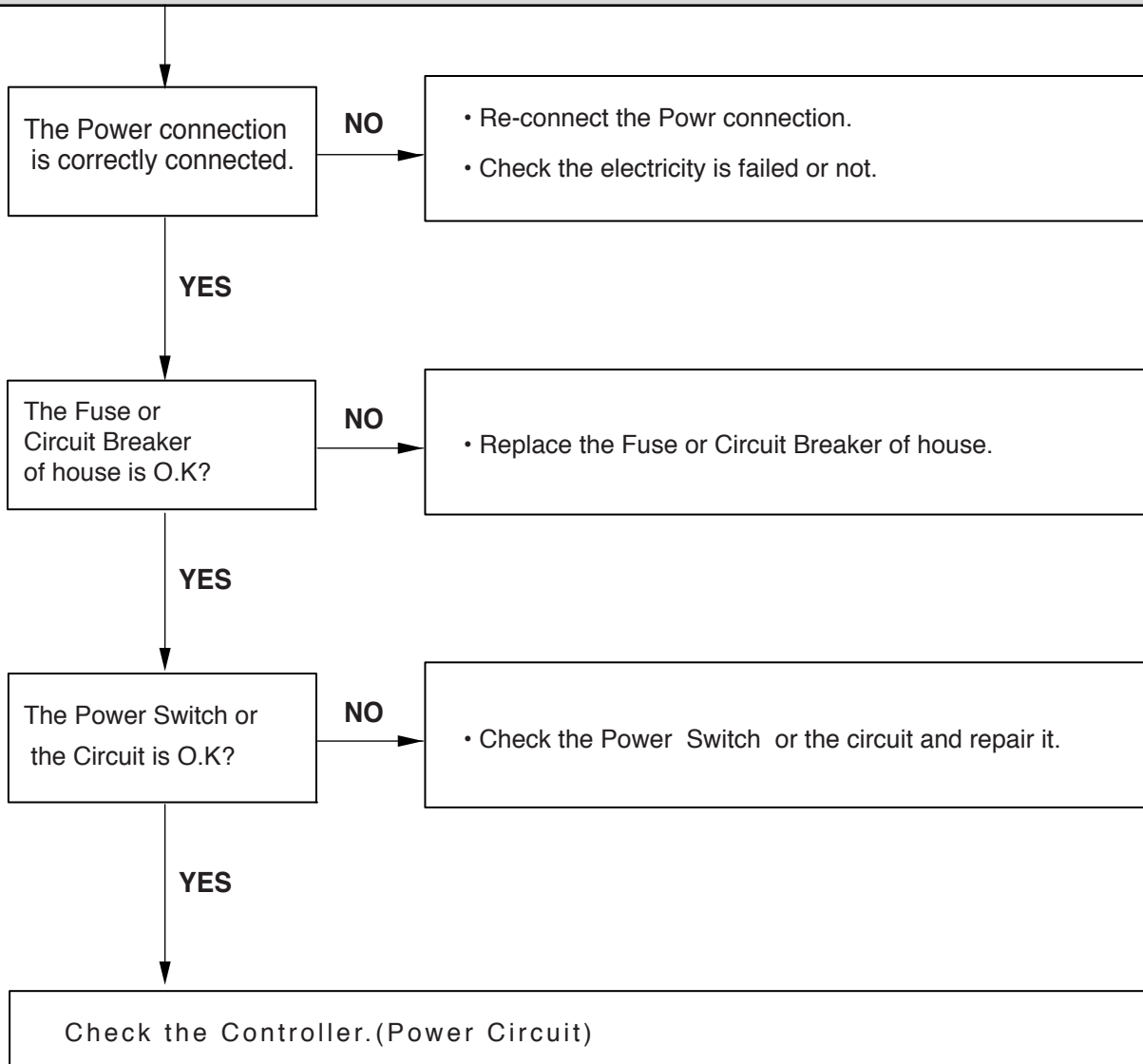

**The Wash Pump/Motor does not run.**

The Door is tightly closed?

**NO**

- close the Door tightly.
- Check the Door Switch in Latch Handle.

**YES**

The Wiring connections is OK?

**NO**

- Re-connect the wiring connections related to the Washing Motor.

**YES**

The Blade is not locked by a small and sharp object?

**NO**

- Remove the cause of lock or replace the Blade.

**YES**

Replace the Wathing Pump/Motor

---

### Washing Results are not Satisfactory

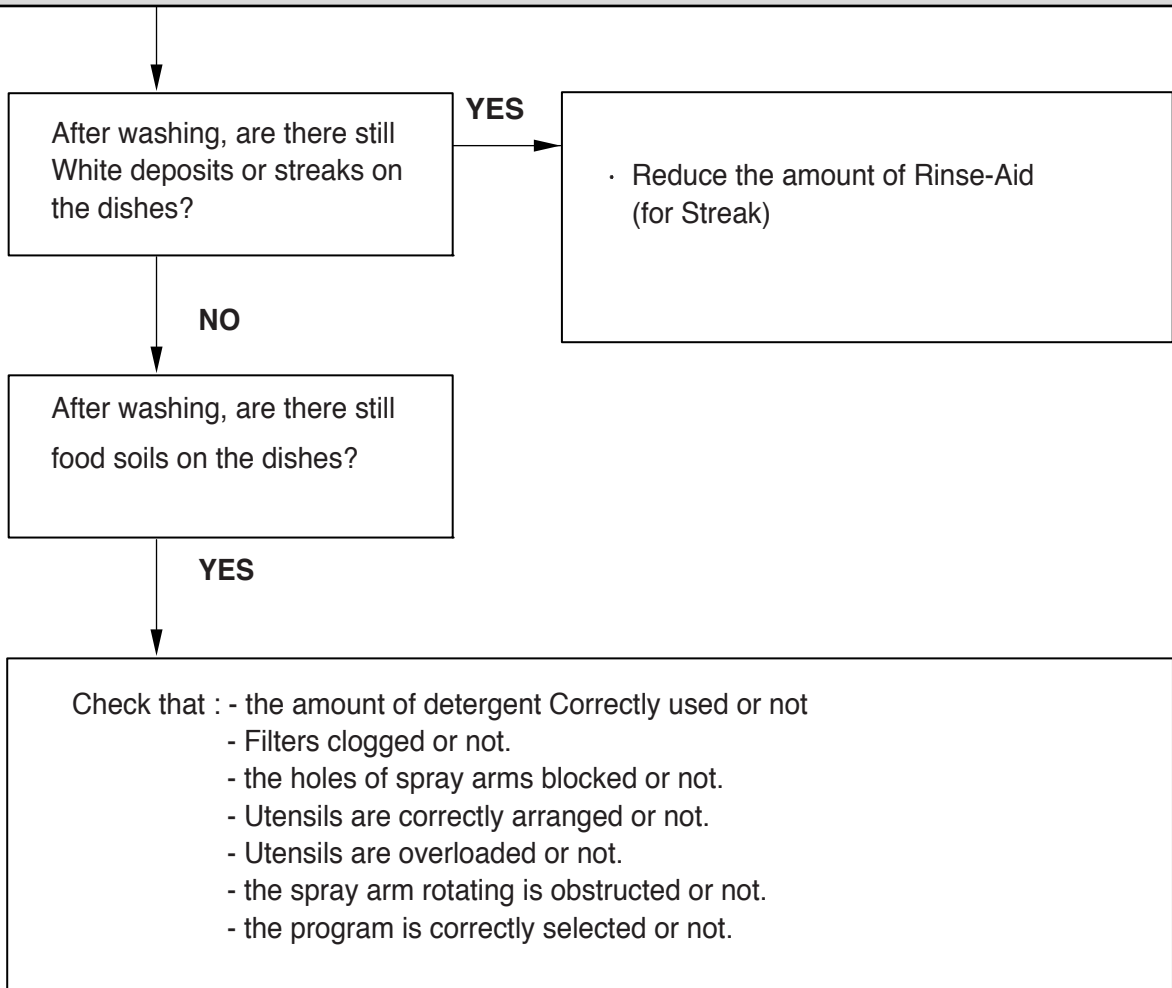

### Dry Results are not satisfactory

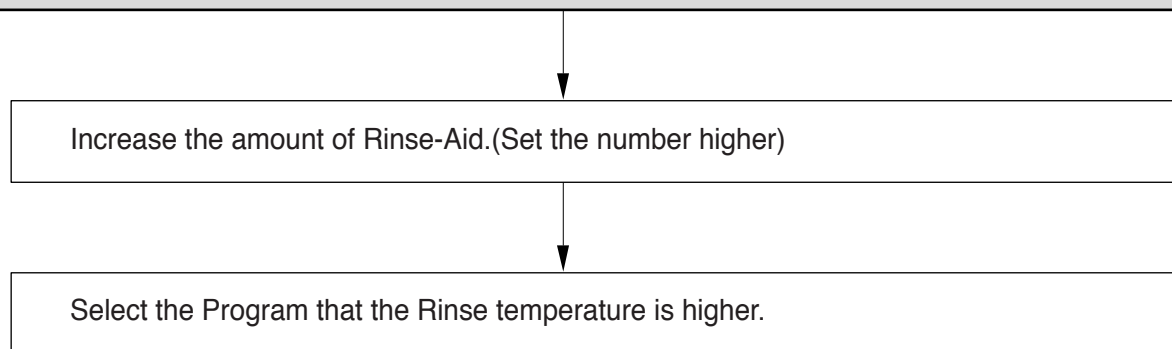

---

**Power Button not automatically off after operation.**

Check the button is blocked by foreign materials.

Check the Power Switch.(Replace it, if necessary.)

Check the Controller.(Replace it, if necessary.)

# 9. INSTALLATION INSTRUCTION

## Step 1: PREPARE CUPBOARD OPENING

1. This dishwasher is designed to fit a standard dishwasher opening as shown below.
2. Select a location as close to sink as possible for easy connections to water and drain lines.
3. The dishwasher should not be installed more than 10 ft. (3m) from the sink for proper drainage.
4. If dishwasher is to be installed in a corner, a minimum of 2 in. (50mm) is required between the dishwasher and an adjacent wall.

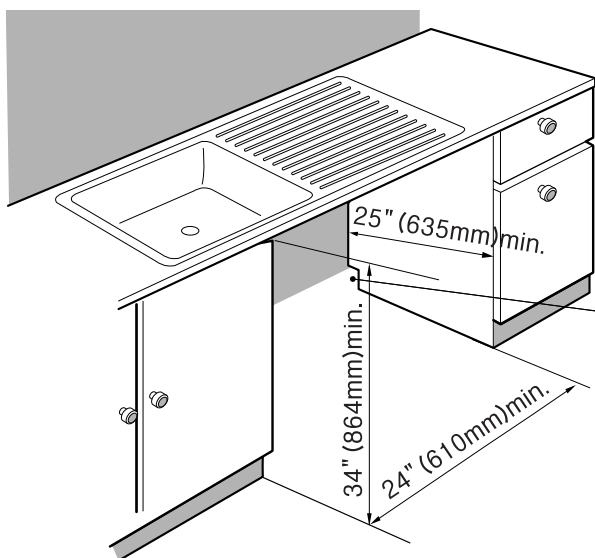

**If dishwasher will sit directly on subflooring, subfloor should be sealed with a waterproof paint or sealer to prevent damage from steam.**

Drill a 1-1/2" (38mm) dia hole or cut out for drain hose, inlet hose and electrical cables on either side.

approx. 4" (100mm, W) X 4" (100mm, H)  
These openings must be within 4" (100mm) from the floor and 1-5/8" (40mm) from the back wall. If there is a floor in the cabinet under the sink, it will also be necessary to drill or cut through the floor to connect the water and drain under the sink.

- Ensure the floor under the dishwasher is at the same level as the rest of the room to allow for any service requirements.

## Step 2: PREPARE THE ELECTRICAL WIRING

### **⚠ WARNING**

For personal safety, remove house fuse or open circuit breaker before installation. Do not use an extension cord or adapter plug with this dishwasher. Electrical and grounding connections must comply with the national electrical code/provincial and municipal code and/or other local codes.

1. This appliance must be operated with correct voltage as shown in this manual and on the rating plate, and connected to an individual, properly grounded branch circuit, protected by time delay fuse. Wiring must be 3 wires including ground.
2. The wiring or cord should be in an accessible location adjacent to, and not behind the dishwasher and within 4 ft. (1.2m) of the dishwasher side.
3. The wiring or cord must be grounded properly, if in doubt, have it checked by a qualified electrician. No other appliance shall be connected to the same outlet by a double adapter or similar plug.
4. The wiring or cord must be oriented as shown in Figure A below.
5. Check the dishwasher for any damage before trying to install it.
6. Make sure water line and Electrical line are oriented in the bottom channels as shown in the figure below.  
If you find any damage to the dishwasher, Please contact your dealer or builder immediately.

**Figure A**

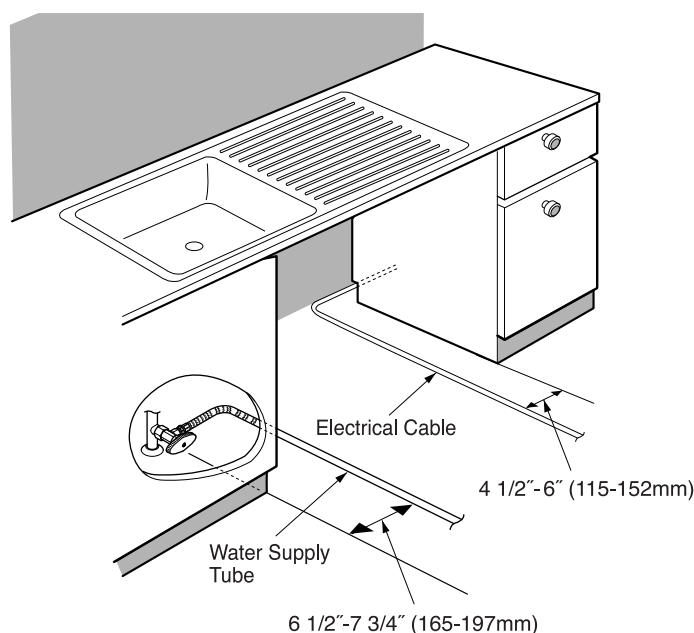

---

### Step 3: PREPARE THE WATER SUPPLY CONNECTION

1. This dishwasher may be connected to either hot or cold water. If the water can not be maintained below 149°F (65°C), the dishwasher must be connected to cold water.
2. When connecting the dishwasher water line, sealing tape or compound should be used to avoid leaks.
3. When connecting the dishwasher water line, the house supply should be shut off.
4. The Water Supply Tube must be oriented as shown in Figure A on page 6.

### Step 4: PREPARE DISHWASHER FOR INSTALLATION

1. Adjust the legs to the required height to fit properly under the countertop as shown below.
2. Check the level of dishwasher by using level.

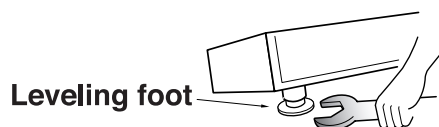

## Step 5: INSTALL THE DISHWASHER IN CUPBOARD

1. Remove the Lower Cover and orient dishwasher as shown below.
2. Before sliding the dishwasher into the cupboard opening, make all necessary height adjustments using the legs.
3. Slide the dishwasher into the cabinet opening carefully. Make sure that the drain hose inside the cabinet is not kinked.
4. Follow the instruction as in Figure B.

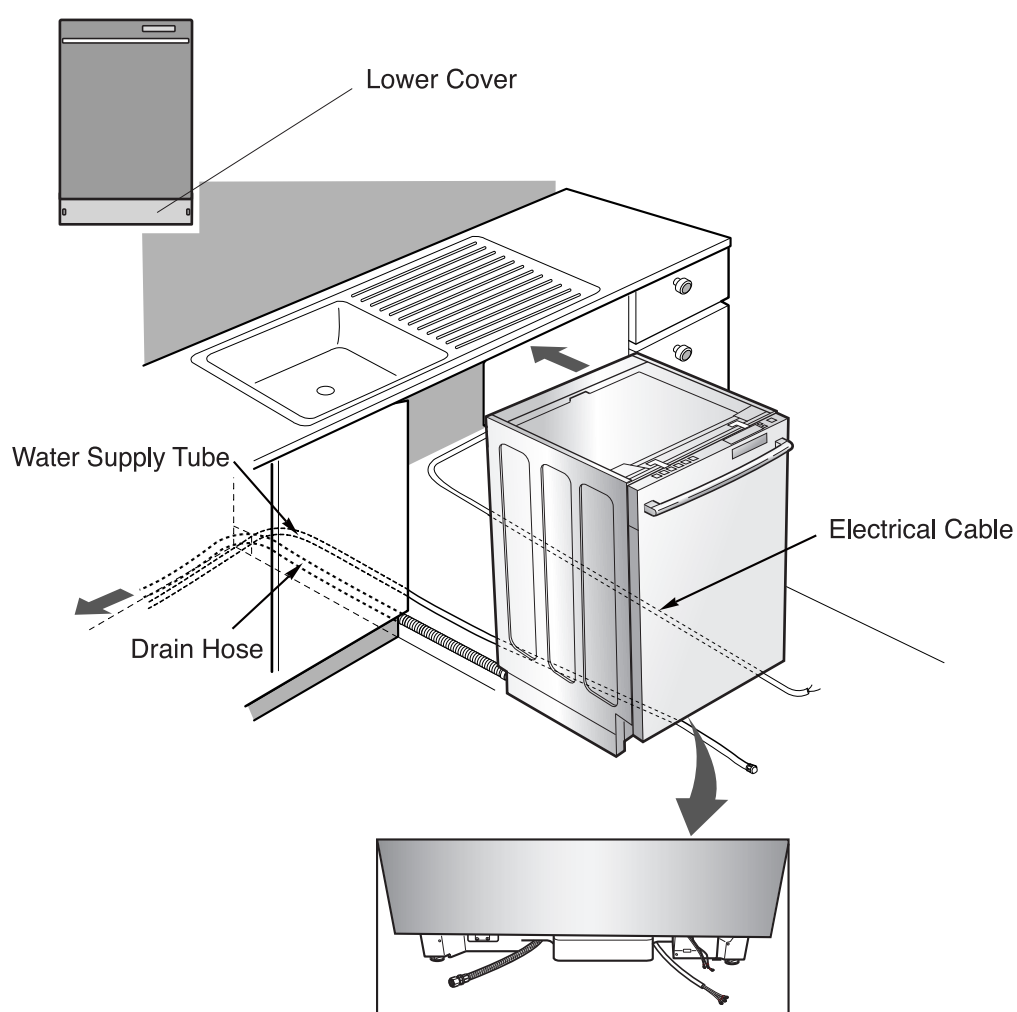

## Step 6: DRAIN LINE CONNECTION

1. If the end of the drain hose does not fit to the drain line, use an adapter (not supplied) that must be resistant to heat and detergent and may be obtained from a plumbing shop.
2. There are 2 typical connections as shown in Figures C & D.
  - ① There may be other options than shown here for connection the drain hose. The drain connection must meet local plumbing regulations.
  - ② The S trap spigot must be drilled out cleanly and free of obstruction to its maximum internal diameter, if used for drainage.
  - ③ To prevent syphoning, one of the following instruction methods must be followed:

**Figure C:** Connection to Disposer or waste Tee.

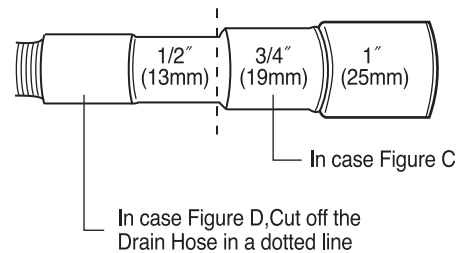
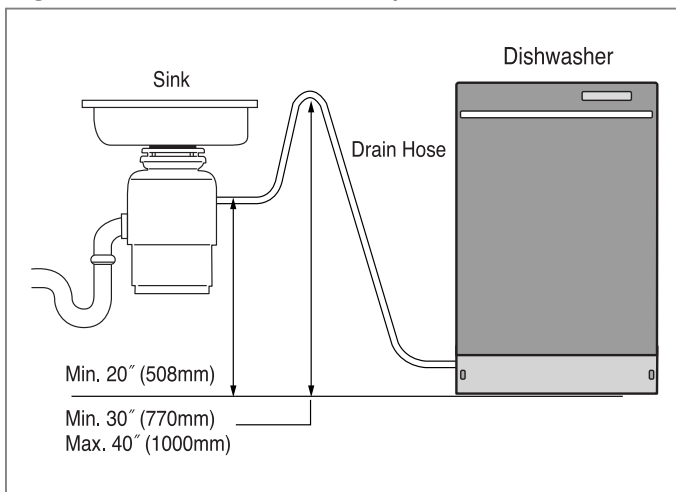

**Figure D:** Connection to Air Gap.

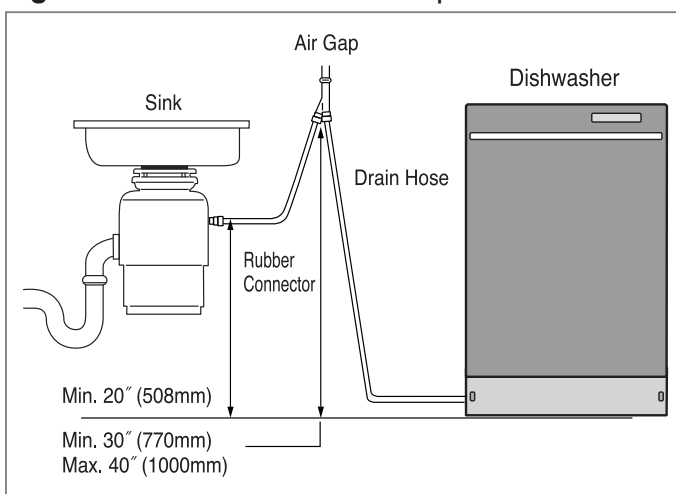

## Drain Requirements

- Follow local codes and ordinances.
- Do not exceed 10 ft. (3m) distance to drain.
- Do not connect drain lines from other devices to the dishwasher drain hose.

## Step 7: WATER SUPPLY CONNECTION

1. When connecting, sealing tape or sealing compound should be used to avoid water leaks.
2. Before connecting, turn off the water supply.
3. After fitting the Elbow into the Inlet Valve, slide the Flexible Stainless Tube or Copper Tube into the Elbow.
4. Tighten the nut and make sure that the line is not kinked or sharply bent.

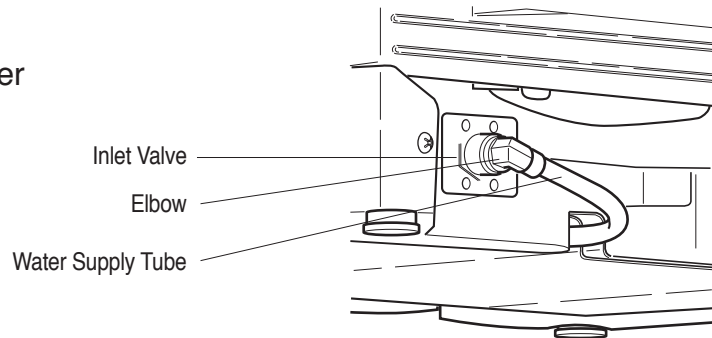

## Step 8: ELECTRICAL POWER CONNECTION

1. Before beginning, turn off electrical power to the unit at the circuit breaker.
2. Remove the Junction Cover and then Install the Strain Relief.
3. Twist Wire Connectors tightly on the wires. Wrap each connection with Electrical tape.
4. Check again and make sure that all wires are connected correctly, black to black, white to white, green to green (ground to ground).
5. Replace the Junction Cover.

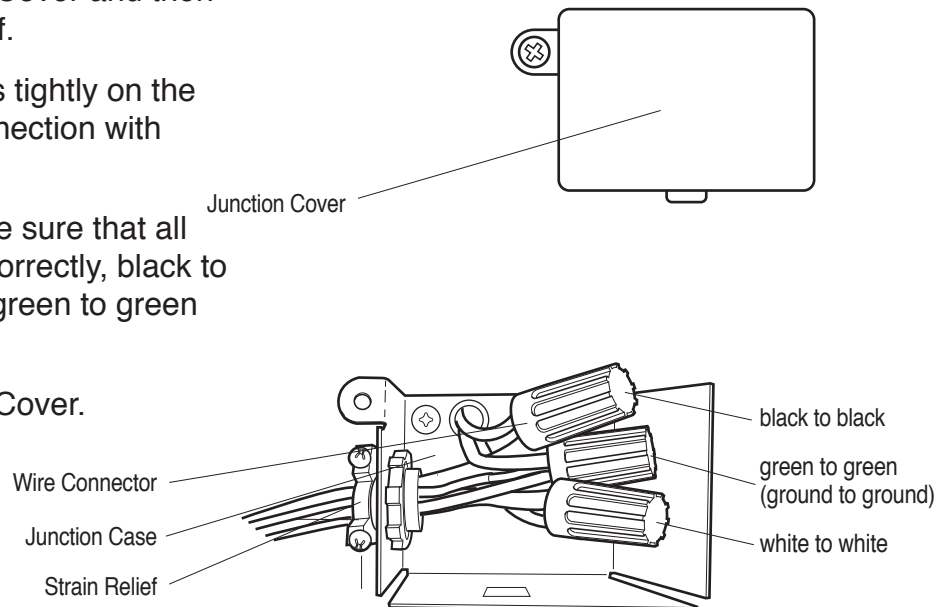

---

## **Step 9: FINAL CHECKS**

1. Turn electrical power back on at the circuit breaker.
2. Turn house water supply back on.
3. Operate the dishwasher through one cycle (Quick cycle is recommended) to check for water leaks and operating conditions.
4. Replace the Lower Cover.

# 10. EXPLODED VIEW

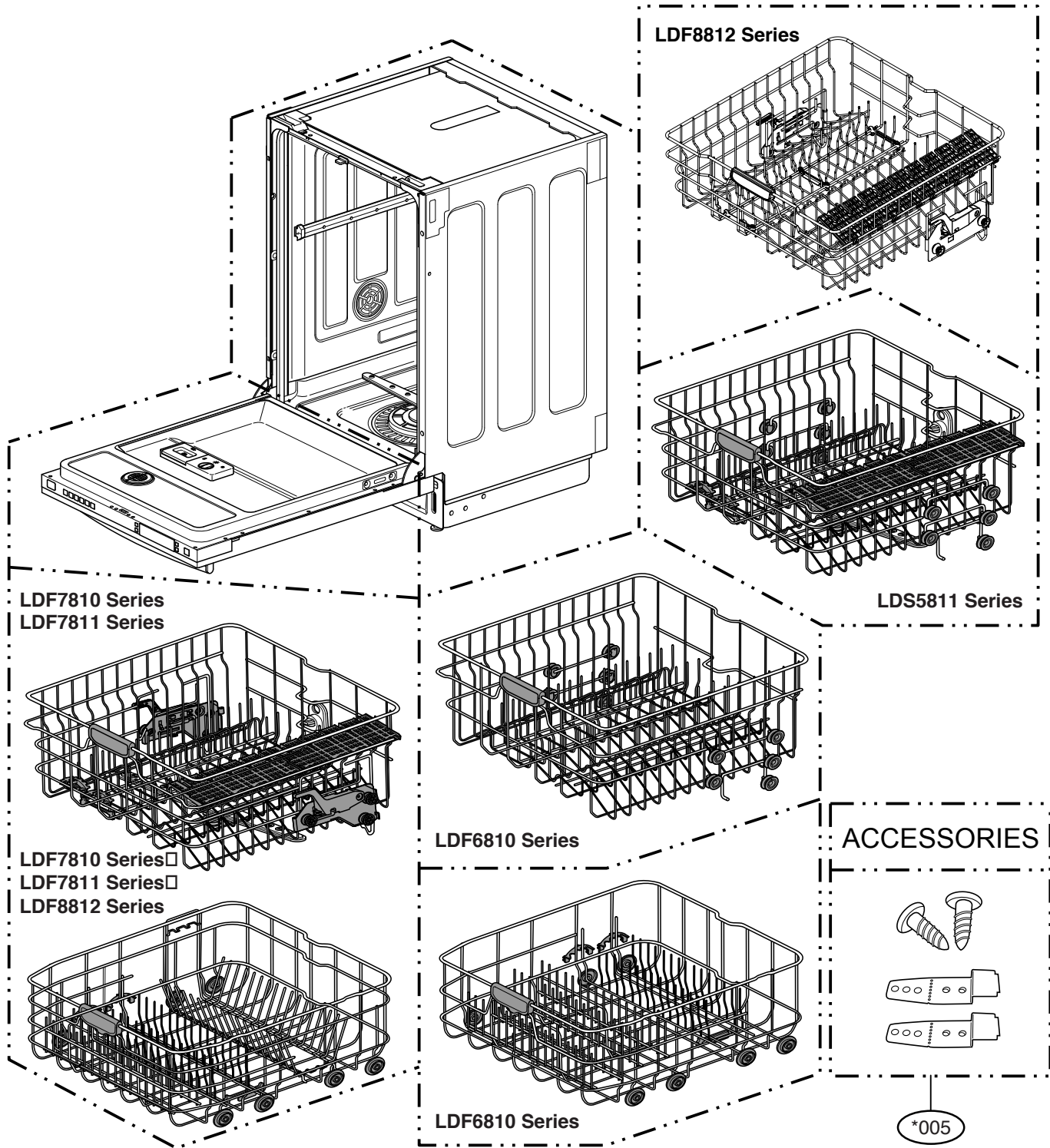

# EXPLODED VIEW

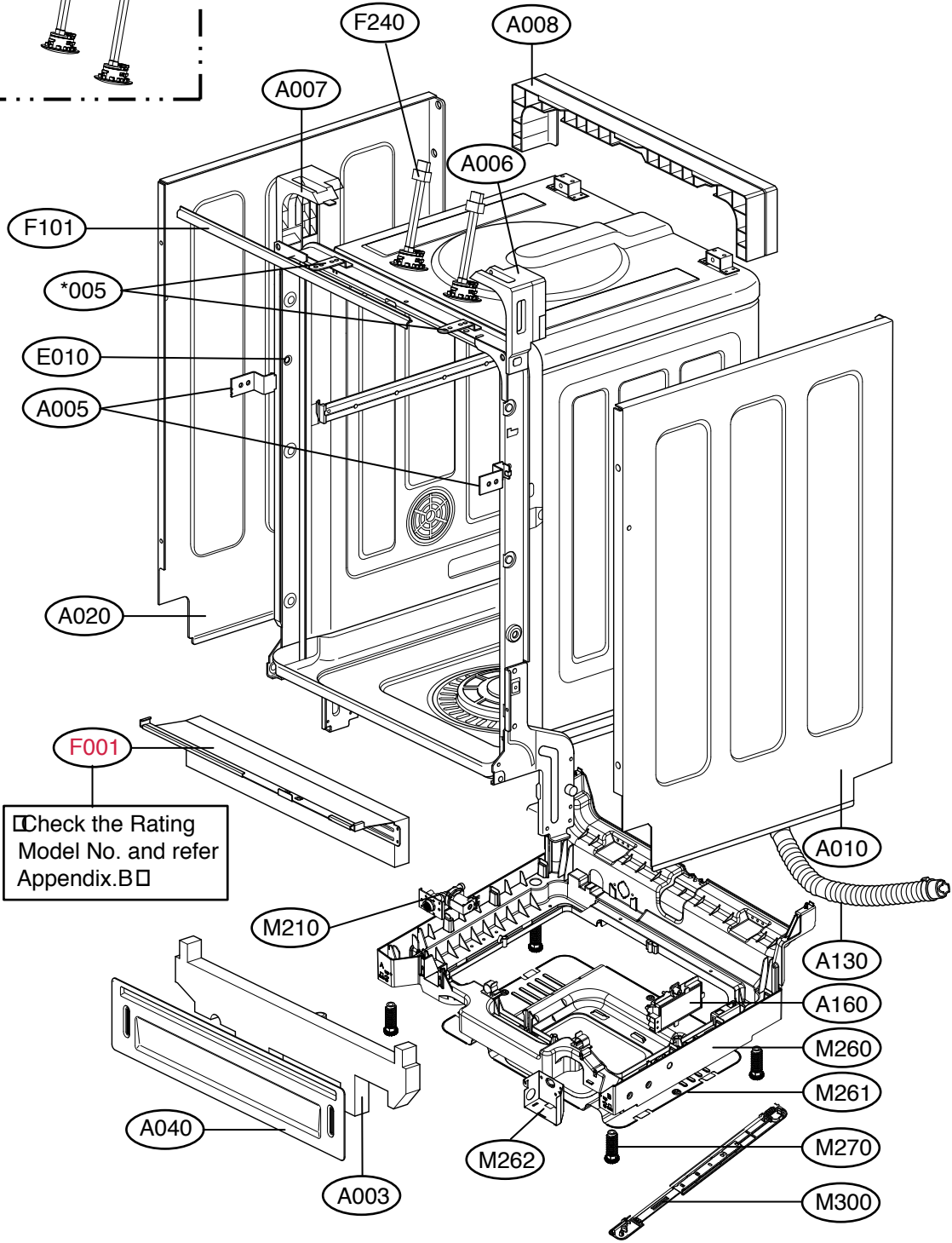
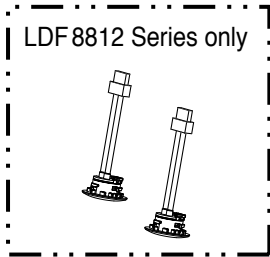

# EXPLODED VIEW - TUB ASSEMBLY

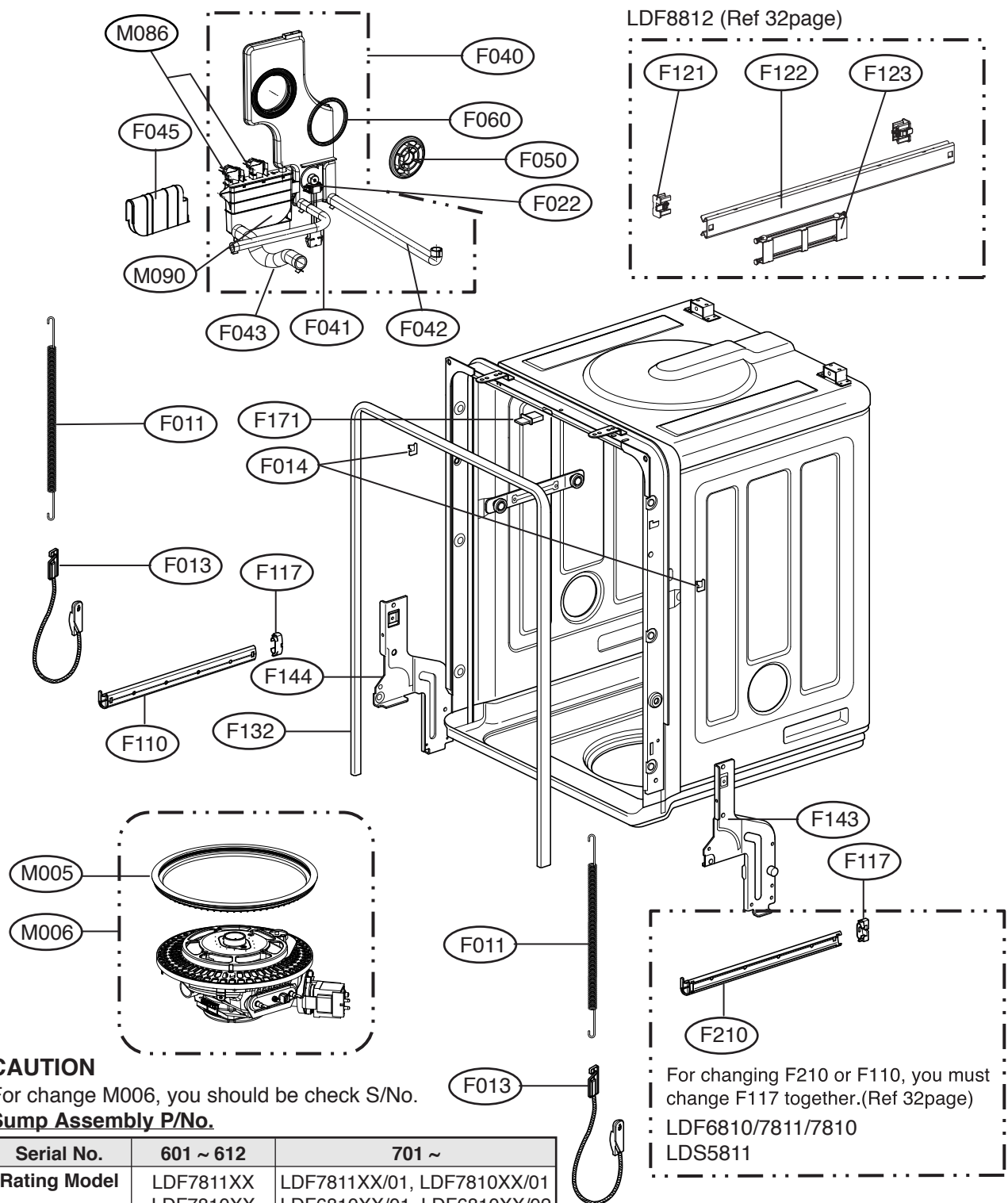

**CAUTION**

For change M006, you should be check S/No.  
**Sump Assembly P/No.**

Serial No.	601 ~ 612	701 ~
Rating Model	LDF7811XX LDF7810XX LDF6810XX LDF6811XX	LDF7811XX/01, LDF7810XX/01 LDF6810XX/01, LDF6810XX/02 LDS5811XX/01, LDS5811XX/02 LDF8812XX, LDF8812XX/01 LDF9810XX, LDF9810XX/01
P/No.	3485ED1002B	AJH31248602

For changing F210 or F110, you must change F117 together. (Ref 32page)  
 LDF6810/7811/7810  
 LDS5811

# EXPLODED VIEW - RACK ASSEMBLY (LDF7811/7810/8812 LDS5811 Series)

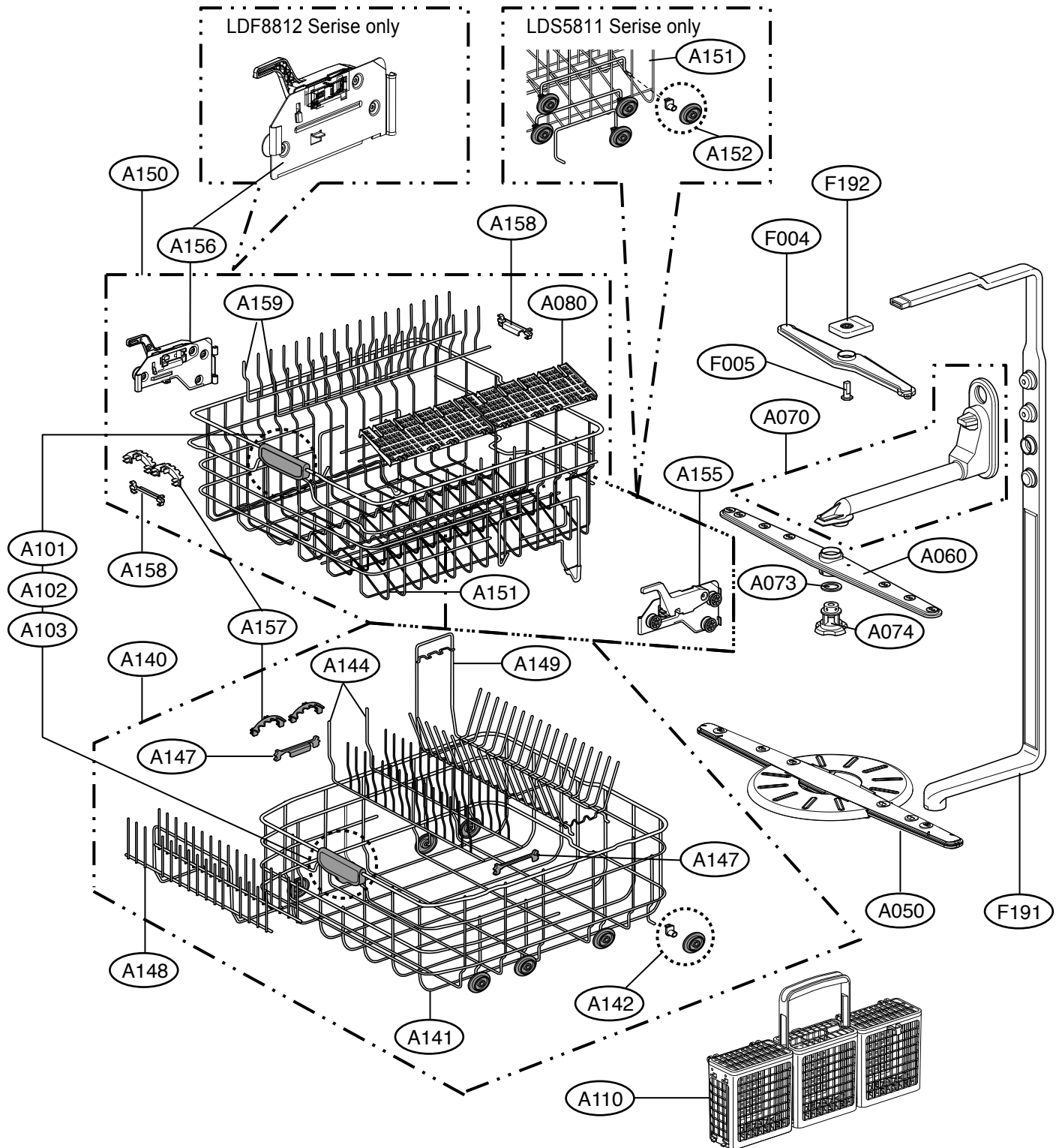

# EXPLODED VIEW - RACK ASSEMBLY (LDF6810 Series)

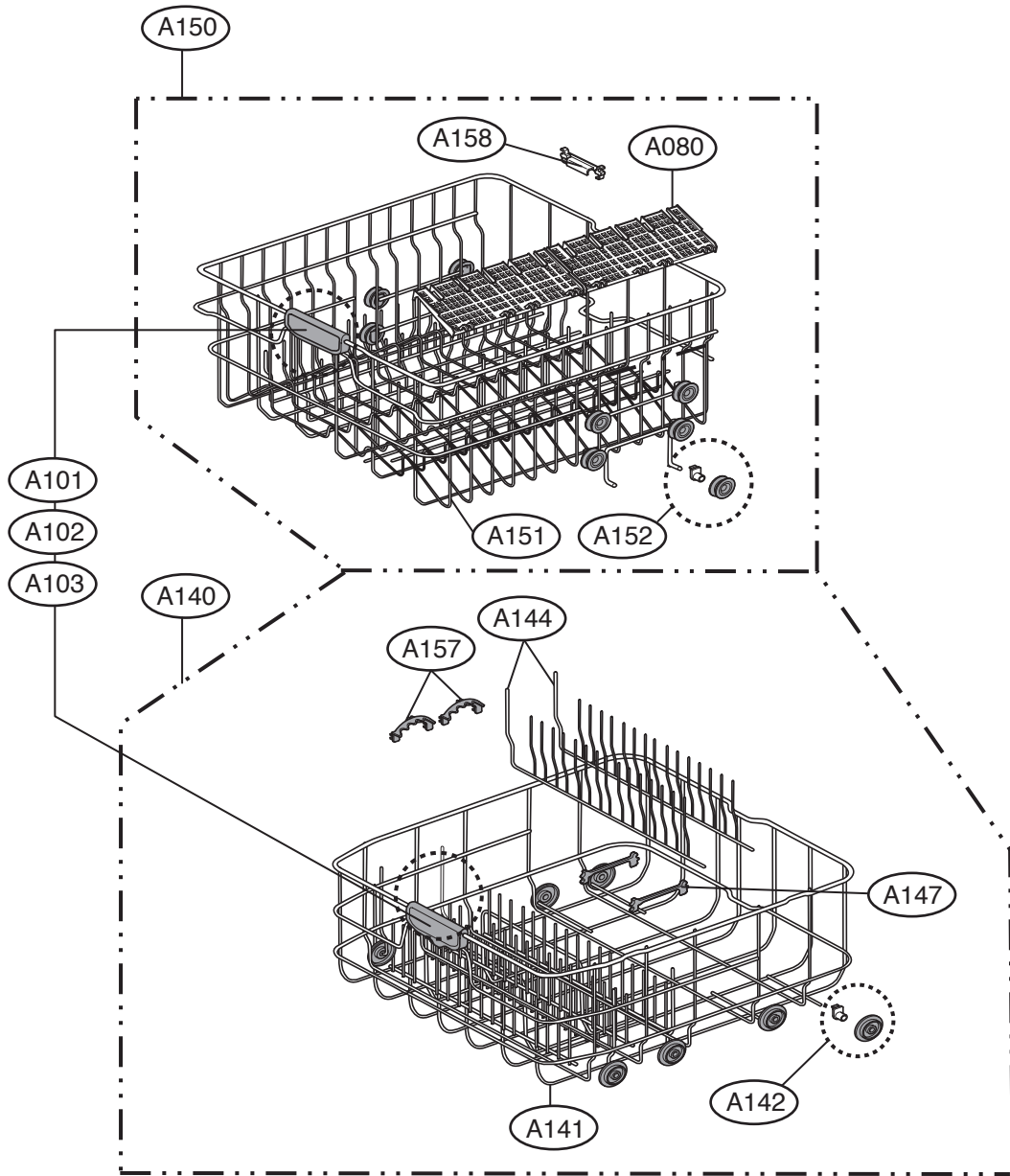

# EXPLODED VIEW - PANEL ASSEMBLY (LDF7811/7810 LDS5811 Series)

## CAUTION

For change K251, you should be check S/No.

**Main PCB Assembly P/No.**

Serial No.	601	602 ~ 612	701~
LDF7811--	6871DD1014A	6871DD1006E	6871DD1006J
LDF7810--	6871DD1014C	6871DD1006G	6871DD1006L
LDS5811--	6871DD1014B	6871DD1006F	6871DD1006K
LDF6811--	6871DD1006D	6871DD1006H	6871DD1006M

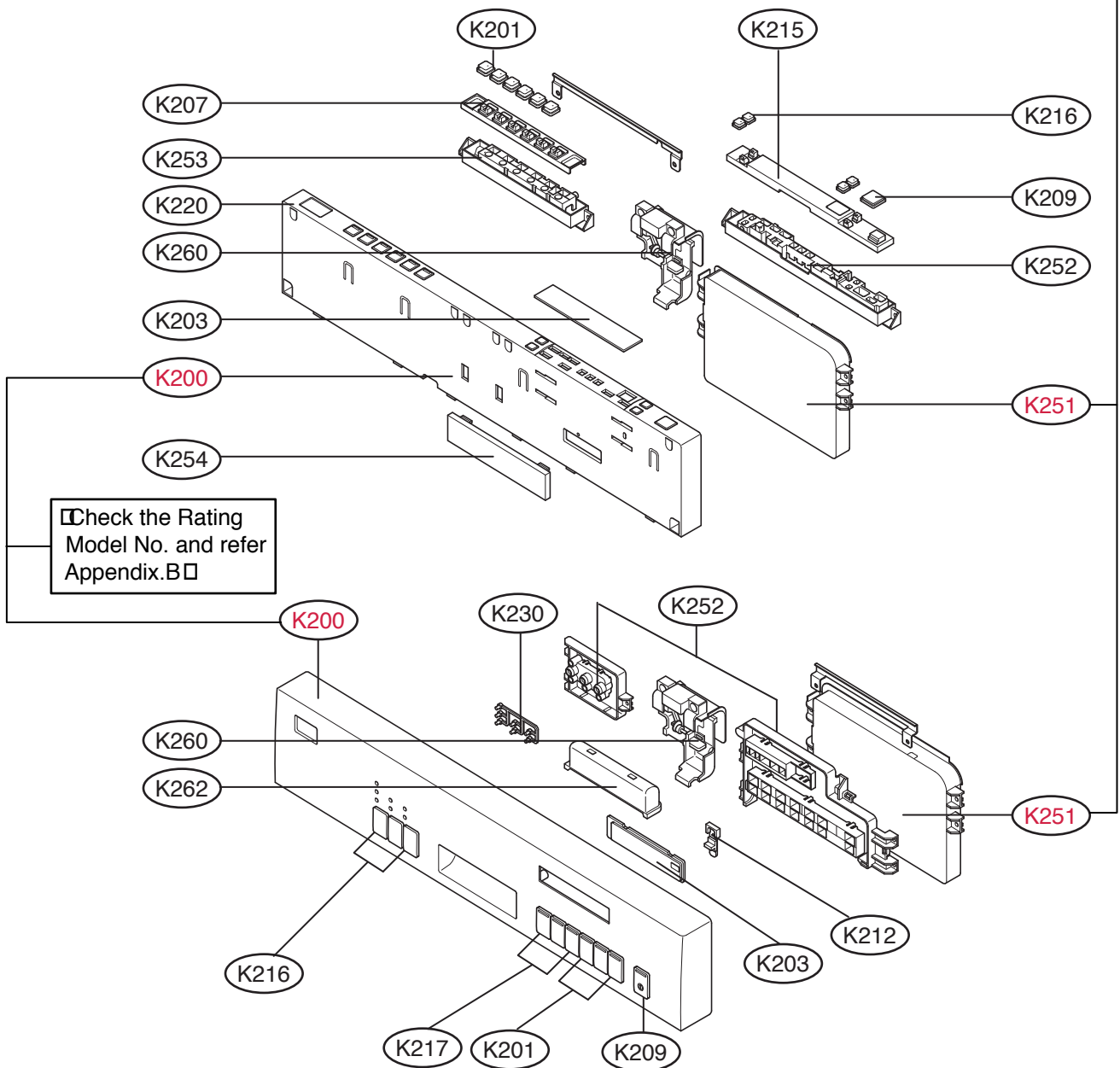

## EXPLODED VIEW - PANEL ASSEMBLY (LDF6810/8812 Series)

### CAUTION

For change K251, you should be check S/No.

**Main PCB Assembly P/No.**

Serial No.	601	602 ~ 612	701~
LDF7811--	6871DD1014A	6871DD1006E	6871DD1006J
LDF7810--	6871DD1014C	6871DD1006G	6871DD1006L
LDS5811--	6871DD1014B	6871DD1006F	6871DD1006K
LDF6811--	6871DD1006D	6871DD1006H	6871DD1006M

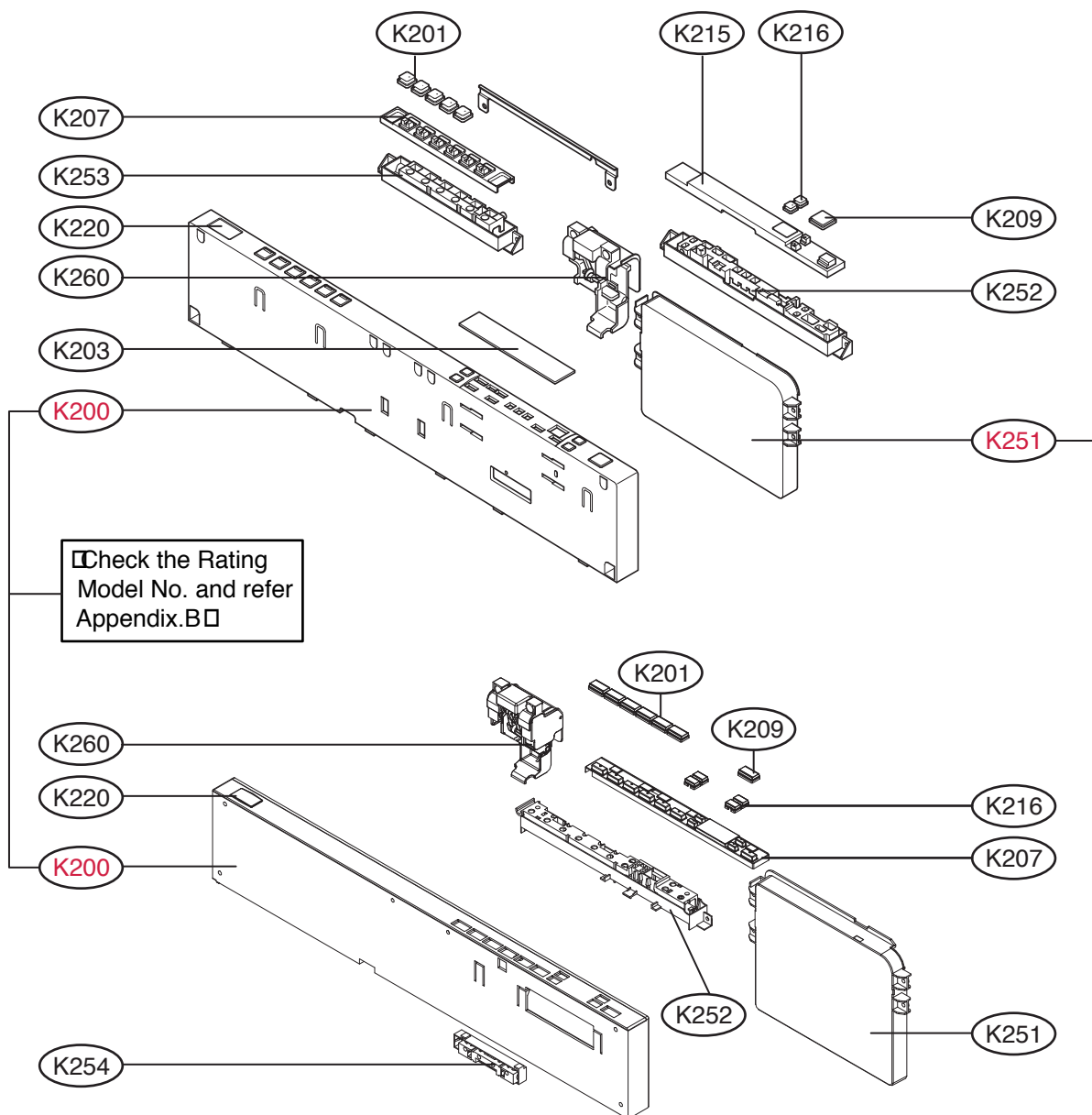

# EXPLODED VIEW – DOOR ASSEMBLY

## CAUTION

Change K100, K110, K124, You should be check Serial No. & Rating Model

\*Check the Rating Model No. and refer Appendix.A

Serial No.	~ 612#####	701##### ~ 711#####	712##### ~
SVC Model	LDF7811XX LDF7810XX LDF6810XX LDS5811XX	LDF7811XX/01 LDF7810XX/01 LDF6810XX/01 LDS5811XX/01 LDF8811XX	LDF6810XX/02 LDS6811XX/02 LDF8812XX/01
K100	4937DD1001A	4937DD1001B	4937DD1001C
K110	5835ED2002B	5835ED2002D	ABT35083801
K124	5232ED2001A	MJZ36939301	MJZ39902101

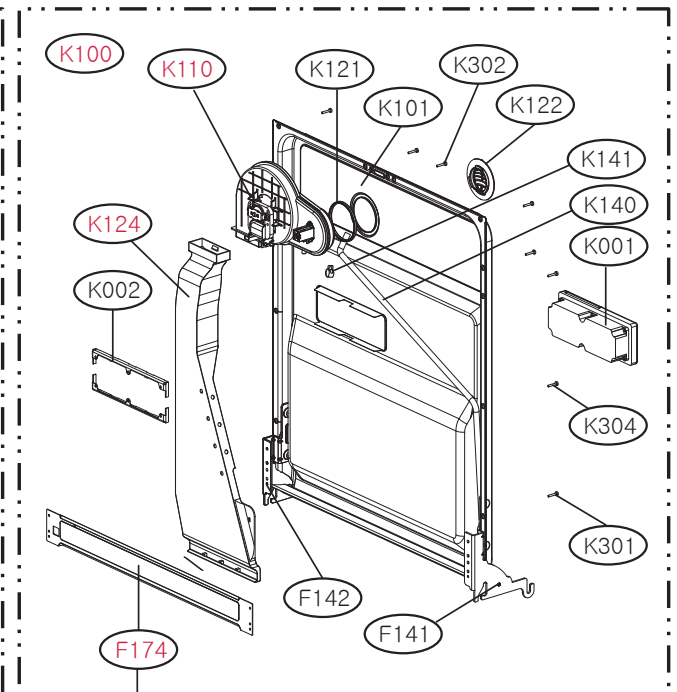
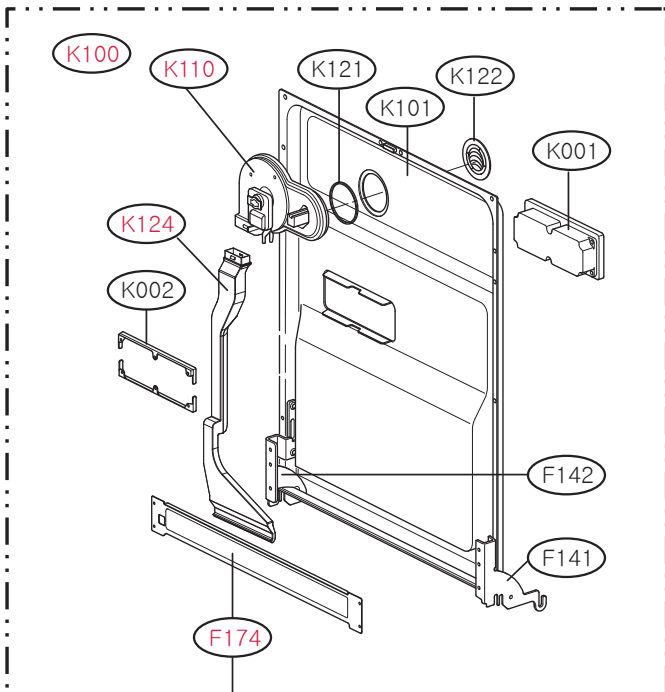
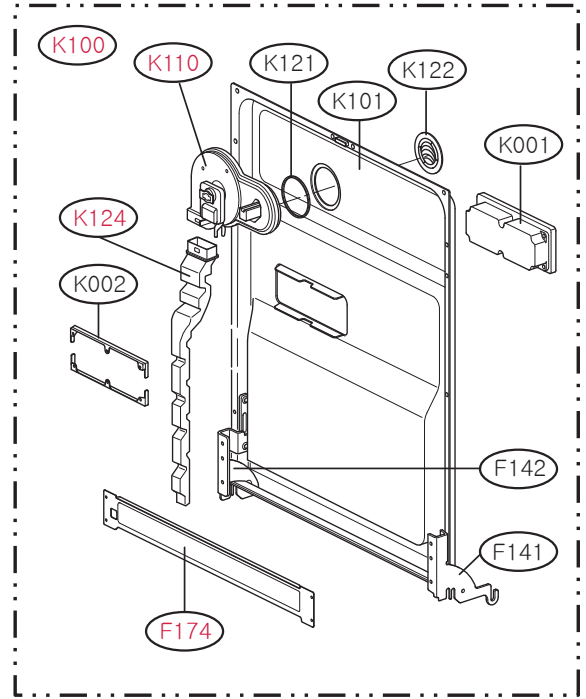

☐ Check the Rating Model No. and refer Appendix.B ☐

# EXPLODED VIEW - DOOR ASSEMBLY

LDF7811Series

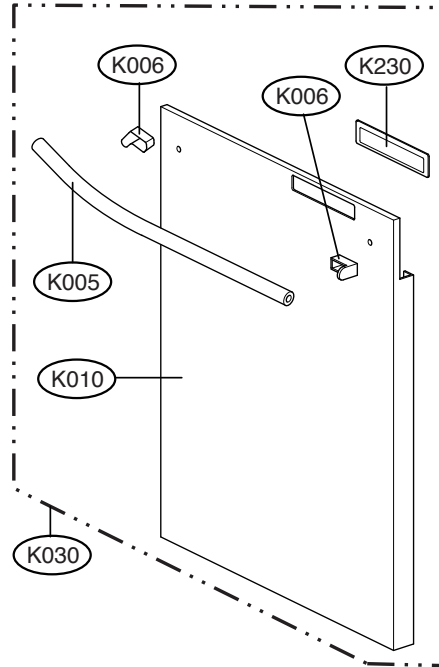

LDF8812Series

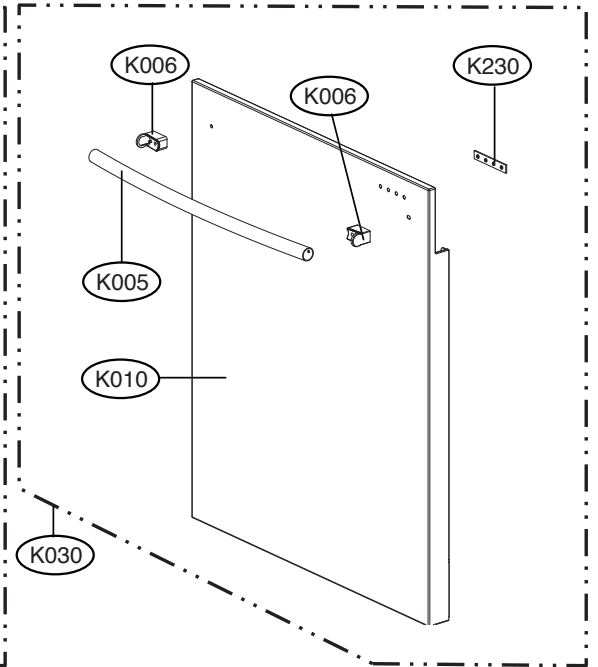

LDF7810/  
LDF6810Series

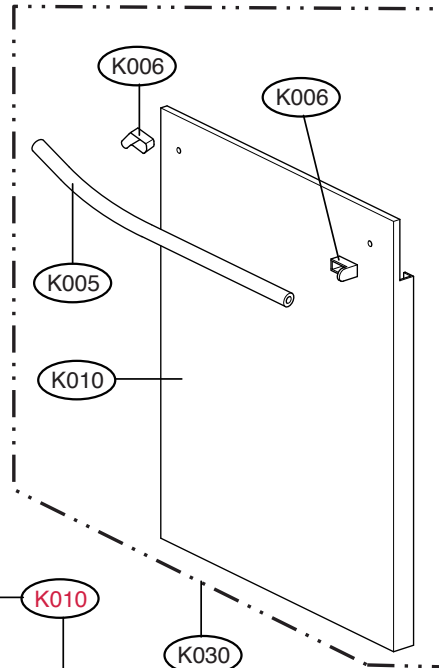

LDF5811Series

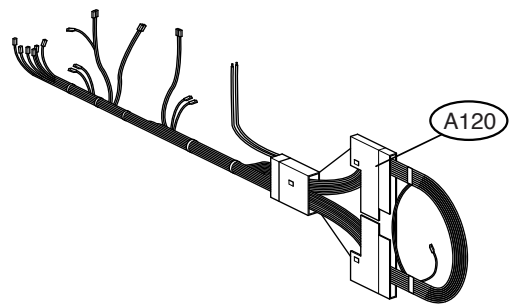
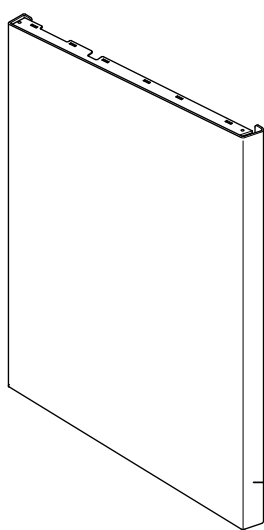

☐ Check the Rating  
Model No. and refer  
Appendix.B ☐

# EXPLODED VIEW - SUMP ASSEMBLY(P/N : 3485ED1002A)

MODEL: LDF6810(WW,BB,ST), LDF7810(WW,BB,ST)  
LDF7811(WW,BB,ST), LDS5811(WW,BB,ST)

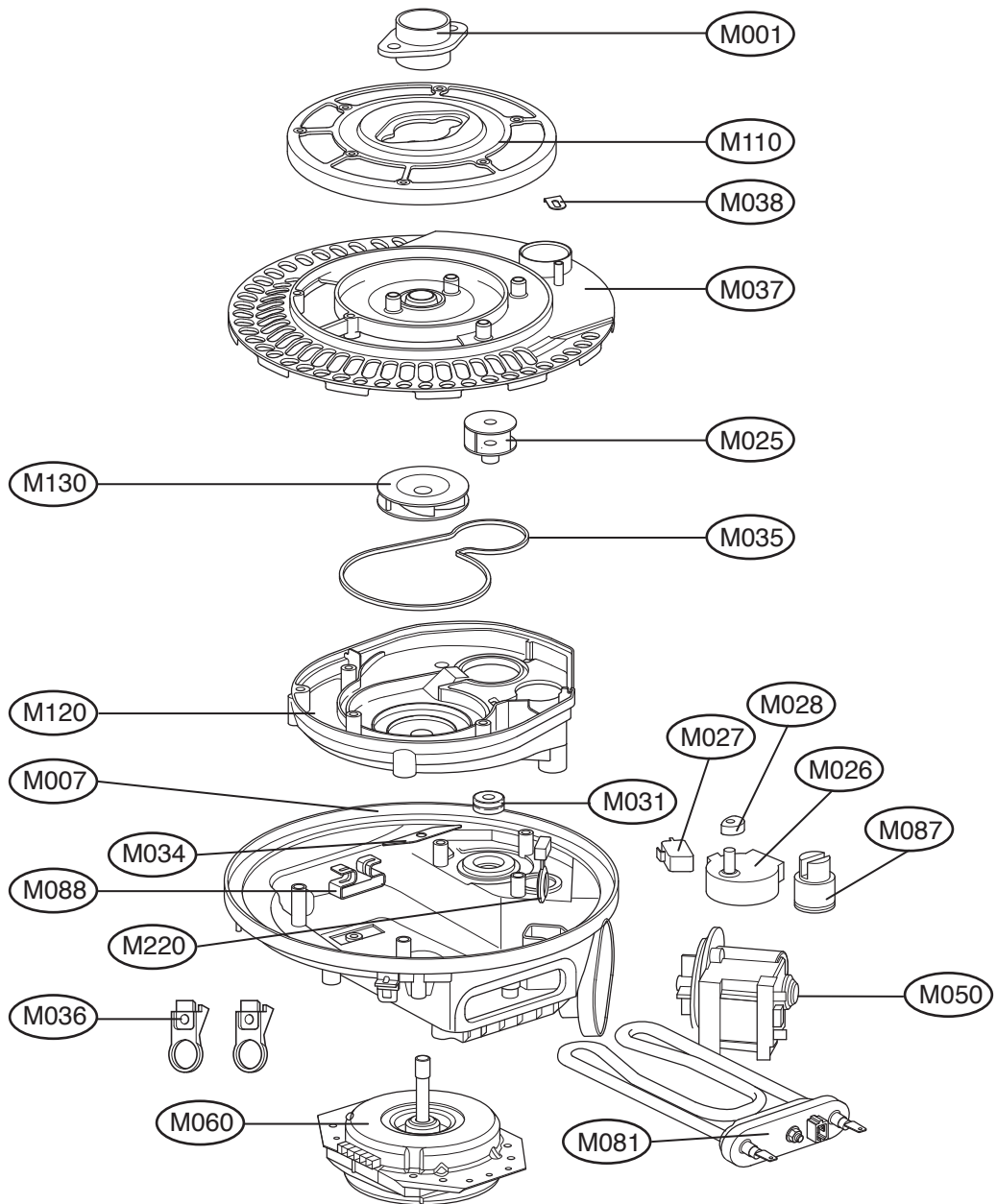

# EXPLODED VIEW - SUMP ASSEMBLY(P/N : AJH31248601)

MODEL : LDF8812(WW,BB,ST), LDF6810(WW,BB,ST)/01, LDF7810(WW,BB,ST)/01  
LDF7811(WW,BB,ST)/01, LDS5811(WW,BB,ST)/01  
LDF8812(WW,BB,ST)/01, LDF6810(WW,BB,ST)/02, LDS5811(WW,BB,ST)/02

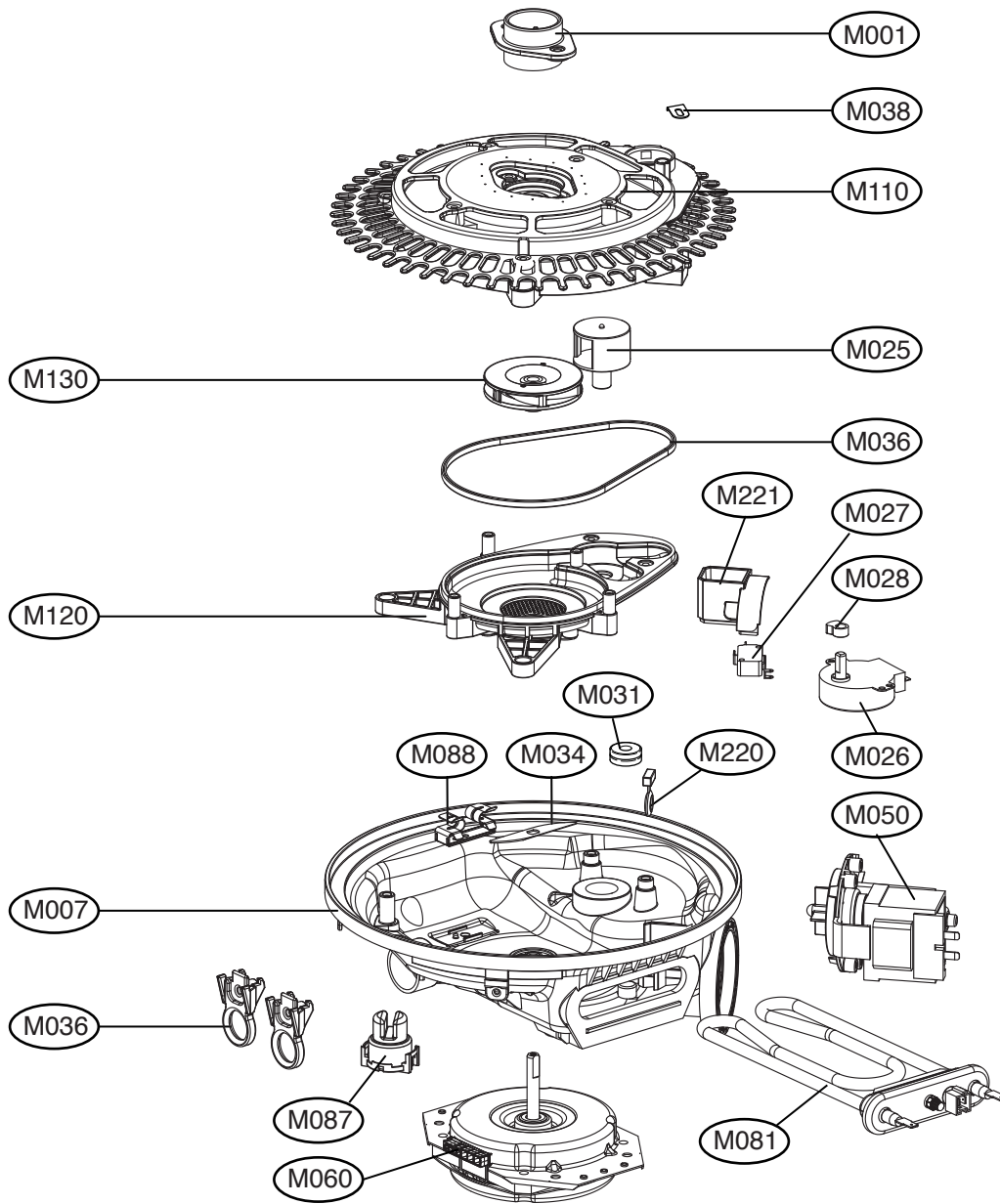

# 11. REPLACEMENT PART LIST

**CAUTION :** BEFORE REPLACING ANY OF THESE COMPONENTS.  
READ CAREFULLY THE SAFETY PRECAUTIONS IN THIS MANUAL

■ **NOTE :** S(SAFETY PARTS), AL(ALTERNATIVE PARTS)

LG MODEL: LD-6100WB/BB/TB		Run Date : 2005-01-30		
YOUR MODEL: LDF7811WW/BB/ST		SPECIFICATION: 120V 60Hz		
LOC	DESC	PART No.	COMMENTS	QTY
*001	MANUAL ASSEMBLY, OWNER'S	3829DD3002B		1
*002	BOX, CARTON	3890DZ3015A		1
*003	MANUAL, SERVICE	3828ED3001X		1
*005	ACCESSORY ASSEMBLY	5001DD4001A		1
A003	FELT	4766DD2004A	LOWER FELT	1
A005	BRACKET, TOP	4810DD4002B		4
A006	SUPPORTER, HOLDER	4980ED2015A		1
A007	SUPPORTER, HOLDER	4980ED2014A		1
A008	SUPPORTER, HOLDER	4980ED2018A		1
A010	CABINET	WB	3090ED1001D	1
		BB	3090ED1001E	1
		ST	3090ED1001F	1
A020	CABINET	WB	3090ED1002D	1
		BB	3090ED1002E	1
		ST	3090ED1002F	1
A040	COVER ASSEMBLY, LOWER	WB	3551DD2001A	1
		BB	3551DD2001B	1
		ST	3551DD2001C	1
A050	NOZZLE ASSEMBLY	5249DD1002A	LOWER NOZZLE	1
A060	NOZZLE ASSEMBLY	5249DD1001A	UPPER NOZZLE	1
A070	GUIDE ASSEMBLY	4974DD9001A		1
A073	WASHER, DRAWING	1WZZDD3001A		1
A074	SHAFT, NOZZLE	4370ED3007A		1
A080	RACK	3750DD2001A	CUP RACK	2
A101	DECO HANDLE	3806DD3004A	STS	1
A102	HANDLE FRONT	3650DD3001A	FRONT	1
A103	HANDLE REAR	3650DD3002A	REAR	1
A110	BASKET ASSEMBLY, SPOON	5005DD1001A		1
A120	HARNESS, PWB	6877DD1002A		1
A130	HOSE ASSEMBLY, DRAIN	5215ED3001E		1
A140	RACK ASSEMBLY	3751DD1001A	LOWER RACK	1
A141	RACK	3750ED1004A		1
A142	ROLLER ASSEMBLY	4581DD9002B		8
A144	RACK	3750DD2003A		2
A147	HOLDER	4930DD3006A		3
A148	RACK	3750DD1001A		1
A149	RACK	3750DD1002A		1
A150	RACK ASSEMBLY	3751DD1002A	UPPER RACK	1
A151	RACK	3750ED1005A		1
A155	GUIDE ASSEMBLY	4975ED2005A	RIGHT	1
A156	GUIDE ASSEMBLY	4975ED2004A	LEFT	1
A157	HOLDER	4930DD3003A		4
A158	HOLDER	4930DD3005A		3
A159	RACK	3750DD2002A		2
A160	FILTER ASSEMBLY (CIRC)	6201EC1006A		1

No.	PART NAME		PART No.	SPEC&COLOR	Q'ty
E010	BUSHING		4830ED4001A		2
F001	FRAME ASSEMBLY		3211DD1001A		1
F004	NOZZLE ASSEMBLY		5249DD2001A	TOP NOZZLE	1
F005	SHAFT NOZZLE		4370ED3006A	TOP NOZZLE	1
F011	SPRING, HINGE		4970ED4004A		2
F013	CONNECTOR ASSEMBLY		4933DD3001A		2
F014	HINGE, BRACKET		4810ED4004A		2
F022	SENSOR ASSEMBLY		6501DD2001A		1
F040	GUIDE ASSEMBLY		4975DD1001A		1
F041	HOSE, INLET		5214DD3001A		1
F042	HOSE, CONNECTOR		5214DD3003A		1
F043	HOSE, CONNECTOR		5214DD3002A		1
F045	COVER, PROTECT		3550DD2001A		1
F050	NUT, DRAWING		4020FD3641C		1
F060	GASKET		4986DD3001A		1
F101	PACKING		3920DD3002A		1
F110	RAIL ASSEMBLY		5219DD2002A	MUST CHANGE F117 TOGETHER(REF 24P-13)	1
F117	STOPPER, ROLLER		4620ED3001A		2
F132	PACKING		3920DD3005A	TUB PACKING	1
F143	HINGE ASSEMBLY		4775ED3004A		1
F144	HINGE ASSEMBLY		4775ED3003A		1
F171	LATCH, LOCK		4026DD3001A		1
F174	BRACKET, HINGE		4810DD1001A	DOOR FRAME	1
F191	GUIDE, WATER		4974DD2003A		1
F192	GUIDE, NOZZLE		4974DD3001A		1
F210	RAIL ASSEMBLY		5219DD2001A	MUST CHANGE F117 TOGETHER(REF 24P-13)	1
K001	DISPENSER		4924FD2123E		1
K002	BRACKET ASSEMBLY		4810FD3805A		2
K005	HANDLE	WB	3650ED2006A		1
		BB	3650ED2006B		1
		ST	3650ED2006C		1
K006	DECO, HANDLE	WB	3806ED3008A		2
		BB	3806ED3008B		2
		ST	3806ED3008C		2
K010	COVER FRONT	WB	3550ED0001A		1
		BB	3550ED0001B		1
		ST	3550ED0001C		1
K030	COVER ASSEMBLY, FRONT	WB	3551DD1003A		1
		BB	3551DD1003B		1
		ST	3551DD1003C		1
K100	DOOR LINER ASM		4937DD9001A	DOOR LINER + DAMPING SHEET + GASKET	1
K110	BLOWER ASSEMBLY		5835ED2002A		1
K121	GASKET		4986DD3003A	BLOWER GASKET	1
K122	COVER, BLOWER		3550ED3011A		1
K124	VENT		5232ED2001A		1
K141	DOOR HINGE ASSEMBLY		4775DD2001A		1
K142	DOOR HINGE ASSEMBLY		4775DD2002A		1
K201	BUTTON, CONTROL	WB	5020ED3008C	PROGRAM BUTTON	6
		BB	5020ED3008D		6
		ST	5020ED3008E		6
K203	WINDOW	WB	3790ED3007A	TOP WINDOW	1
		BB	3790ED3007D		1

No.	PART NAME		PART No.	SPEC&COLOR	Q'ty
K203	WINDOW	ST	3790ED3007E		1
K207	COVER, GUIDE		3550ED3012A		1
K208	PANEL, CONTROL	WB	3720ED1005A		1
		BB	3720ED1005B		1
		ST	3720ED1005C		1
K209	BUTTON, POWER SWITCH	WB	5020ED3011A		1
		BB	5020ED3011B		1
		ST	5020ED3011A		1
K215	COVER, GUIDE		3550ED1009A		1
K216	BUTTON, CONTROL	WB	5020ED3012C	OPTION BUTTON	4
		BB	5020ED3012D		4
		ST	3791DD3001E		1
K220	MARK, PET	WB	3846ER1001A		1
		BB	3846ER1001B		1
		ST	3846ER1001A		1
K230	WINDOW	WB	3791DD3001A	FRONT WINDOW	1
		BB	3791DD3001B		1
		ST	3791DD3001B		1
K251	PWB(PCB) ASSEMBLY, MAIN		6871DD1006A		1
K252	PWB(PCB) ASSEMBLY, DISPLAY		6871DD2001A		1
K253	PWB(PCB) ASSEMBLY, DISPLAY		6871DD2002A		1
K254	DISPLAY LED ASSEMBLY		6327DC3001A		1
K260	LATCH, ASSEMBLY		4027ED3002A		1
M001	HOLDER		4930DD3002A		1
M005	GASKET		4986DD3002A	SUMP GASKET	1
M006	SUMP, ASSEMBLY		3485ED1002A		1
M007	SUMP		3485DD1001A	SUMP+SEAL+GREASE	1
M025	VALVE, CHECK		5220DD3001A		1
M026	MOTOR ASSEMBLY, WM		4681ED3001B	VARIO MOTOR	1
M027	SWITCH, MICRO		3W40025C		1
M028	CAM, SWITCH		4430ED3001A		1
M031	PACKING		3920ED4009B	VARIO PACKING	1
M034	BLADE		5832DD4001A		1
M035	SEAL		4036DD3001A		1
M036	HOLDER		4930DD3008A		1
M037	FILTER ASSEMBLY, MESH		5231DD1001A		1
M038	HOLDER		4930DD3012A		1
M050	MOTOR ASSEMBLY, PUMP		4681EA2002D	DRAIN MOTOR	1
M060	MOTOR ASSEMBLY, WM		4681ED1004A		1
M081	HEATER ASSEMBLY		5301DD1001A		1
M086	MICRO S/W		3W40025P		2
M087	SENSOR ASSEMBLY		6501ED2002D	SOIL SENSOR	1
M088	PROTECTOR (MECH)		3740ED3003A		1
M090	FLOAT ASSEMBLY		4769DD2001A		1
M110	FILTER ASSEMBLY, MESH		5231ED1001A		1
M120	CASE ASSEMBLY		3111DD1001A		1
M130	IMPELLER ASSEMBLY		5911ED3003A		1
M210	VALVE ASSEMBLY, INLET		5221DD1001A		1
M220	VALVE, CHECK		5220ED4004A		1
M260	BASE, CABINET		MAM34326301		1
M261	COVER ASSEMBLY, BASE		ACQ31707201		1
M262	CASE		3110DD3002A		1
M270	LEG		4778DD3001A		1
M300	ACCESSORY ASSEMBLY		5001DD2001D	GUIDE ASSY + LEG	1

**CAUTION** : BEFORE REPLACING ANY OF THESE COMPONENTS.  
 READ CAREFULLY THE SAFETY PRECAUTIONS IN THIS MANUAL

■ **NOTE** : **S**(SAFETY PARTS), **AL**(ALTERNATIVE PARTS)

LG MODEL: LD-6090WB/BB/TB		Run Date : 2005-01-30		
YOUR MODEL: LDS5811WW/BB/ST		SPECIFICATION: 120V 60Hz		
LOC	DESC	PART No.	COMMENTS	QTY
*001	MANUAL ASSEMBLY, OWNER'S	3829DD3002C		1
*002	BOX, CARTON	3890DZ3015A		1
*003	MANUAL, SERVICE	3828ED3001X		1
*005	ACCESSORY ASSEMBLY	5001DD4001A		1
A003	FELT	4766DD2004A	LOWER FELT	1
A005	BRACKET, TOP	4810DD4002B		4
A006	SUPPORTER, HOLDER	4980ED2015A		1
A007	SUPPORTER, HOLDER	4980ED2014A		1
A008	SUPPORTER, HOLDER	4980ED2018A		1
A010	CABINET	WB	3090ED1001D	1
		BB	3090ED1001E	1
		ST	3090ED1001F	1
A020	CABINET	WB	3090ED1002D	1
		BB	3090ED1002E	1
		ST	3090ED1002F	1
A040	COVER ASSEMBLY, LOWER	WB	3551DD2001A	1
		BB	3551DD2001B	1
		ST	3551DD2001C	1
A050	NOZZLE ASSEMBLY	5249DD1002A	LOWER NOZZLE	1
A060	NOZZLE ASSEMBLY	5249DD1001A	UPPER NOZZLE	1
A070	GUIDE ASSEMBLY	4974DD9001A		1
A073	WASHER, DRAWING	1WZZDD3001A		1
A074	SHAFT, NOZZLE	4370ED3007A		1
A080	RACK	3750DD2001A	CUP RACK	2
A101	DECO HANDLE	3806DD3004A	STS	1
A102	HANDLE FRONT	3650DD3001A	FRONT	1
A103	HANDLE REAR	3650DD3002A	REAR	1
A110	BASKET ASSEMBLY, SPOON	5005DD1001A		1
A120	HARNESS, PWB	6877DD1002A		1
A130	HOSE ASSEMBLY, DRAIN	5215ED3001E		1
A140	RACK ASSEMBLY	3751DD1001A	LOWER RACK	1
A141	RACK	3750ED1004A		1
A142	ROLLER ASSEMBLY	4581DD9002B		8
A144	RACK	3750DD2003A		2
A147	HOLDER	4930DD3006A		3
A148	RACK	3750DD1001A		1
A149	RACK	3750DD1002A		1
A150	RACK ASSEMBLY	3751DD1002B	UPPER RACK	1
A151	RACK	3750ED1005B		1
A152	ROLLER ASM	4581DD9001A		10
A157	HOLDER	4930DD3003A		4
A158	HOLDER	4930DD3005A		3
A159	RACK	3750DD2002A		2
A160	FILTER ASSEMBLY (CIRC)	6201EC1006A		1
E010	BUSHING	4830ED4001A		2

No.	PART NAME	PART No.	SPEC&COLOR	Q'ty
F001	FRAME ASSEMBLY	3211DD1001A		1
F004	NOZZLE ASSEMBLY	5249DD2001A	TOP NOZZLE	1
F005	SHAFT NOZZLE	4370ED3006A	TOP NOZZLE	1
F011	SPRING, HINGE	4970ED4004A		2
F013	CONNECTOR ASSEMBLY	4933DD3001A		2
F014	HINGE, BRACKET	4810ED4004A		2
F022	SENSOR ASSEMBLY	6510DD2001A		1
F040	GUIDE ASSEMBLY	4975DD1001A		1
F041	HOSE, INLET	5214DD3001A		1
F042	HOSE, CONNECTOR	5214DD3003A		1
F043	HOSE, CONNECTOR	5214DD3002A		1
F045	COVER, PROTECT	3550DD2001A		1
F050	NUT, DRAWING	4020FD3641C		1
F060	GASKET	4986DD3001A		1
F101	PACKING	3920DD3002A		1
F110	RAIL ASSEMBLY	5219DD2002A	MUST CHANGE F117 TOGETHER(REF 24P-13)	1
F117	STOPPER, ROLLER	4620ED3001A		2
F132	PACKING	3920DD3005A	TUB PACKING	1
F143	HINGE ASSEMBLY	4775ED3004A		1
F144	HINGE ASSEMBLY	4775ED3003A		1
F171	LATCH, LOCK	4026DD3001A		1
F174	BRACKET, HINGE	4810DD1001A	DOOR FRAME	1
F191	GUIDE, WATER	4974DD2003A		1
F192	GUIDE, NOZZLE	4974DD3001A		1
F210	RAIL ASSEMBLY	5219DD2001A	MUST CHANGE F117 TOGETHER(REF 24P-13)	1
K001	DISPENSER	4924FD2123E		1
K002	BRACKET ASSEMBLY	4810FD3805A		2
K010	COVER ASSEMBLY, FRONT	WB	3551DD1004A	1
		BB	3551DD1004B	1
		ST	3551DD1004D	1
K100	DOOR LINER ASM	4937DD9001A	DOOR LINER + DAMPING SHEET + GASKET	1
K110	BLOWER ASSEMBLY	5835ED2002A		1
K121	GASKET	4986DD3003A	BLOWER GASKET	1
K122	COVER, BLOWER	3550ED3011A		1
K124	VENT	5232ED2001A		1
K141	DOOR HINGE ASSEMBLY	4775DD2001A		1
K142	DOOR HINGE ASSEMBLY	4775DD2002A		1
K201	BUTTON, CONTROL	WB	5020DD2001A	1
		BB	5020DD2001B	1
		ST	5020DD2001C	1
K203	WINDOW	WB	3790DD3001A	1
		BB	3790DD3001B	1
		ST	3790DD3001B	1
K208	PANEL, CONTROL	WB	3720DD1001A	1
		BB	3720DD1001B	1
		ST	3720DD1001C	1
K209	BUTTON, POWER SWITCH	WB	5020DD2004A	1
		BB	5020DD2004B	1
		ST	5020DD2004C	1

No.	PART NAME	PART No.	SPEC&COLOR	Q'ty
K212	BUTTON, CONTROL	5020DD3001A	DELAY START	1
K216	BUTTON, CONTROL	WB	5020DD2003A	OPTION BUTTON
		BB	5020DD2003B	
		ST	5020DD2003C	
K217	BUTTON, CONTROL	WB	5020DD2002A	PROGRAM BUTTON
		BB	5020DD2002B	
		ST	5020DD2002C	
K220	MARK, PET	WB	3846ER1001A	
		BB	3846ER1001B	
		ST	3846ER1001A	
K230	WINDOW	3790DD3002A	OPTION WINDOW	1
K251	PWB(PCB) ASSEMBLY, MAIN	6871DD1006B		1
K252	PWB(PCB) ASSEMBLY, DISPLAY	6871DD2003A		1
K260	LATCH, ASSEMBLY	4027ED3002A		1
K262	HANDLE	WB	3650DD2005A	
		BB	3650DD2005B	
		ST	3650DD2005C	
M001	HOLDER	4930DD3002A		1
M005	GASKET	4986DD3002A	SUMP GASKET	1
M006	SUMP, ASSEMBLY	3485ED1002A		1
M007	SUMP	3485DD1001A	SUMP+SEAL+GREASE	1
M025	VALVE, CHECK	5220DD3001A		1
M026	MOTOR ASSEMBLY, WM	4681ED3001B	VARIO MOTOR	1
M027	SWITCH, MICRO	3W40025C		1
M028	CAM, SWITCH	4430ED3001A		1
M031	PACKING	3920ED4009B	VARIO PACKING	1
M034	BLADE	5832DD4001A		1
M035	SEAL	4036DD3001A		1
M036	HOLDER	4930DD3008A		1
M037	FILTER ASSEMBLY, MESH	5231DD1001A		1
M038	HOLDER	4930DD3012A		1
M050	MOTOR ASSEMBLY, PUMP	4681EA2002D	DRAIN MOTOR	1
M060	MOTOR ASSEMBLY, WM	4681ED1004A		1
M081	HEATER ASSEMBLY	5301DD1001A		1
M086	MICRO S/W	3W40025P		1
M087	SENSOR ASSEMBLY	6501ED2002D	SOIL SENSOR	1
M088	PROTECTOR (MECH)	3740ED3003A		1
M090	FLOAT ASSEMBLY	4769DD2001A		1
M110	FILTER ASSEMBLY, MESH	5231ED1001A		1
M120	CASE ASSEMBLY	3111DD1001A		1
M130	IMPELLER ASSEMBLY	5911ED3003A		1
M210	VALVE ASSEMBLY, INLET	5221DD1001A		1
M220	VALVE, CHECK	5220ED4004A		1
M260	BASE, CABINET	MAM34326301		1
M261	COVER ASSEMBLY, BASE	ACQ31707201		1
M262	CASE	3110DD3002A		1
M270	LEG	4778DD3001A		1
M300	ACCESSORY ASSEMBLY	5001DD2001D	GUIDE ASSY + LEG	1

**CAUTION** : BEFORE REPLACING ANY OF THESE COMPONENTS.  
 READ CAREFULLY THE SAFETY PRECAUTIONS IN THIS MANUAL

■ **NOTE** : S(SAFETY PARTS), AL(ALTERNATIVE PARTS)

LG MODEL: LD-6105WB/BB/TB		Run Date : 2005-01-30		
YOUR MODEL: LDF7810WW/BB/ST		SPECIFICATION: 120V 60Hz		
LOC	DESC	PART No.	COMMENTS	QTY
*001	MANUAL ASSEMBLY, OWNER'S	3829DD3002B		1
*002	BOX, CARTON	3890DZ3015A		1
*003	MANUAL, SERVICE	3828ED3001X		1
*005	ACCESSORY ASSEMBLY	5001DD4001A		1
A003	FELT	4766DD2004A	LOWER FELT	1
A005	BRACKET, TOP	4810DD4002B		4
A006	SUPPORTER, HOLDER	4980ED2015A		1
A007	SUPPORTER, HOLDER	4980ED2014A		1
A008	SUPPORTER, HOLDER	4980ED2018A		1
A010	CABINET	WB	3090ED1001D	1
		BB	3090ED1001E	1
		ST	3090ED1001F	1
A020	CABINET	WB	3090ED1002D	1
		BB	3090ED1002E	1
		ST	3090ED1002F	1
A040	COVER ASSEMBLY, LOWER	WB	3551DD2001A	1
		BB	3551DD2001B	1
		ST	3551DD2001C	1
A050	NOZZLE ASSEMBLY	5249DD1002A	LOWER NOZZLE	1
A060	NOZZLE ASSEMBLY	5249DD1001A	UPPER NOZZLE	1
A070	GUIDE ASSEMBLY	4974DD9001A		1
A073	WASHER, DRAWING	1WZZDD3001A		1
A074	SHAFT, NOZZLE	4370ED3007A		1
A080	RACK	3750DD2001A	CUP RACK	2
A101	DECO HANDLE	3806DD3004A	STS	1
A102	HANDLE FRONT	3650DD3001A	FRONT	1
A103	HANDLE REAR	3650DD3002A	REAR	1
A110	BASKET ASSEMBLY, SPOON	5005DD1001A		1
A120	HARNESS, PWB	6877DD1002A		1
A130	HOSE ASSEMBLY, DRAIN	5215ED3001E		1
A140	RACK ASSEMBLY	3751DD1001A	LOWER RACK	1
A141	RACK	3750ED1004A		1
A142	ROLLER ASSEMBLY	4581DD9002B		8
A144	RACK	3750DD2003A		2
A147	HOLDER	4930DD3006A		3
A148	RACK	3750DD1001A		1
A149	RACK	3750DD1002A		1
A150	RACK ASSEMBLY	3751DD1002A	UPPER RACK	1
A151	RACK	3750ED1005A		1
A155	GUIDE ASSEMBLY	4975ED2005A	RIGHT	1
A156	GUIDE ASSEMBLY	4975ED2004A	LEFT	1
A157	HOLDER	4930DD3003A		4
A158	HOLDER	4930DD3005A		3
A159	RACK	3750DD2002A		2
A160	FILTER ASSEMBLY (CIRC)	6201EC1006A		1

No.	PART NAME		PART No.	SPEC&COLOR	Q'ty
E010	BUSHING		4830ED4001A		2
F001	FRAME ASSEMBLY		3211DD1001A		1
F004	NOZZLE ASSEMBLY		5249DD2001A	TOP NOZZLE	1
F005	SHAFT NOZZLE		4370ED3006A	TOP NOZZLE	1
F011	SPRING, HINGE		4970ED4004A		2
F013	CONNECTOR ASSEMBLY		4933DD3001A		2
F014	HINGE, BRACKET		4810ED4004A		2
F022	SENSOR ASSEMBLY		6501DD2001A		1
F040	GUIDE ASSEMBLY		4975DD1001A		1
F041	HOSE, INLET		5214DD3001A		1
F042	HOSE, CONNECTOR		5214DD3003A		1
F043	HOSE, CONNECTOR		5214DD3002A		1
F045	COVER, PROTECT		3550DD2001A		1
F050	NUT, DRAWING		4020FD3641C		1
F060	GASKET		4986DD3001A		1
F101	PACKING		3920DD3002A		1
F110	RAIL ASSEMBLY		5219DD2002A	MUST CHANGE F117 TOGETHER(REF 24P-13)	1
F013	CONNECTOR ASSEMBLY		4933DD3001A		2
F117	STOPPER, ROLLER		4620ED3001A		2
F132	PACKING		3920DD3005A	TUB PACKING	1
F143	HINGE ASSEMBLY		4775ED3004A		1
F144	HINGE ASSEMBLY		4775ED3003A		1
F171	LATCH, LOCK		4026DD3001A		1
F174	BRACKET, HINGE		4810DD1001A	DOOR FRAME	1
F191	GUIDE, WATER		4974DD2003A		1
F192	GUIDE, NOZZLE		4974DD3001A		1
F210	RAIL ASSEMBLY		5219DD2001A	MUST CHANGE F117 TOGETHER(REF 24P-13)	1
K001	DISPENSER		4924FD2123E		1
K002	BRACKET ASSEMBLY		4810FD3805A		2
K005	HANDLE	WB	3650ED2006A/D		1
		BB	3650ED2006B		1
		ST	3650ED2006C		1
K006	DECO, HANDLE	WB	3806ED3008A		1
		BB	3806ED3008B		2
		ST	3806ED3008C		2
K010	COVER FRONT	WB	3550ED0001E		1
		BB	3551ED0001F		1
		ST	3550ED0001G		1
K030	COVER ASSEMBLY, FRONT	WB	3551DD1001E/H		1
		BB	3551DD1003F		1
		ST	3551DD1003G		1
K100	DOOR LINER ASM		4937DD9001A	DOOR LINER + DAMPING SHEET + GASKET	1
K110	BLOWER ASSEMBLY		5835ED2002A		1
K121	GASKET		4986DD3003A	BLOWER GASKET	1
K122	COVER, BLOWER		3550ED3011A		1
K124	VENT		5232ED2001A		1
K141	DOOR HINGE ASSEMBLY		4775DD2001A		1
K142	DOOR HINGE ASSEMBLY		4775DD2002A		1
K201	BUTTON, CONTROL	WB	5028ED3008C	PROGRAM BUTTON	1
		BB	5020ED3008D		6
		ST	5020ED3008E		6

No.	PART NAME		PART No.	SPEC&COLOR	Q'ty
K203	WINDOW	WB	3790ED3007D	TOP WINDOW	1
		BB	3790ED3007D		1
		ST	3790ED3007E		1
K207	COVER, GUIDE		3550ED3012A		1
K208	PANEL, CONTROL	WB	3720ED1005A		1
		BB	3720ED1005B		1
		ST	3720ED1005C		1
K209	BUTTON, POWER SWITCH	WB	5020ED3011A		1
		BB	5020ED3011B		1
		ST	5020ED3011A		1
K215	COVER, GUIDE		3550ED1009A		1
K216	BUTTON, CONTROL	WB	5020ED3012C	OPTION BUTTON	1
		BB	5020ED3012D		4
		ST	5020ED3012E		4
K220	MARK, PET	WB	3846ER1001A		1
		BB	3846ER1001B		1
		ST	3846ER1001A		1
K251	PWB(PCB) ASSEMBLY, MAIN		6871DD1006A		1
K252	PWB(PCB) ASSEMBLY, DISPLAY		6871DD2001A		1
K253	PWB(PCB) ASSEMBLY, DISPLAY		6871DD2002A		1
K260	LATCH, ASSEMBLY		4027ED3002A		1
M001	HOLDER		4930DD3002A		1
M005	GASKET		4986DD3002A	SUMP GASKET	1
M006	SUMP, ASSEMBLY		3485ED1002A		1
M007	SUMP		3485DD1001A	SUMP+SEAL+GREASE	1
M025	VALVE, CHECK		5220DD3001A		1
M026	MOTOR ASSEMBLY, WM		4681ED3001B	VARIO MOTOR	1
M027	SWITCH, MICRO		3W40025C		1
M028	CAM, SWITCH		4430ED3001A		1
M031	PACKING		3920ED4009B	VARIO PACKING	1
M034	BLADE		5832DD4001A		1
M035	SEAL		4036DD3001A		1
M036	HOLDER		4930DD3008A		1
M037	FILTER ASSEMBLY, MESH		5231DD1001A		1
M038	HOLDER		4930DD3012A		1
M050	MOTOR ASSEMBLY, PUMP		4681EA2002D	DRAIN MOTOR	1
M060	MOTOR ASSEMBLY, WM		4681ED1004A		1
M081	HEATER ASSEMBLY		5301DD1001A		1
M086	MICRO S/W		3W40025P		1
M087	SENSOR ASSEMBLY		6501ED2002D	SOIL SENSOR	1
M088	PROTECTOR (MECH)		3740ED3003A		1
M090	FLOAT ASSEMBLY		4769DD2001A		1
M110	FILTER ASSEMBLY, MESH		5231ED1001A		1
M120	CASE ASSEMBLY		3111DD1001A		1
M130	IMPELLER ASSEMBLY		5911ED3003A		1
M210	VALVE ASSEMBLY, INLET		5221DD1001A		1
M220	VALVE, CHECK		5220ED4004A		1
M260	BASE, CABINET		MAM34326301		1
M261	COVER ASSEMBLY, BASE		ACQ31707201		1
M262	CASE		3110DD3002A		1
M270	LEG		4778DD3001A		1
M300	ACCESSORY ASSEMBLY		5001DD2001D	GUIDE ASSY+LEG	1

**CAUTION** : BEFORE REPLACING ANY OF THESE COMPONENTS.

READ CAREFULLY THE SAFETY PRECAUTIONS IN THIS MANUAL

■ **NOTE** : S(SAFETY PARTS), AL(ALTERNATIVE PARTS)

LG MODEL: LD-6300WB/BB/TB			Run_Date : 2005-01-30	
YOUR MODEL: LDF6810WW/BB/ST			SPECIFICATION: 120V 60Hz	
LOC	DESC	PART No.	COMMENTS	QTY
*001	MANUAL ASSEMBLY, OWNER'S	3829DD3005M		1
*002	BOX, CARTON	3890DZ3015A		1
*003	MANUAL, SERVICE	3828ED3001X		1
*005	ACCESSORY ASSEMBLY	5001DD4001A		1
A003	FELT	4766DD2004A	LOWER FELT	1
A005	BRACKET, TOP	4810DD4002B		4
A006	SUPPORTER, HOLDER	4980ED2015A		1
A007	SUPPORTER, HOLDER	4980ED2014A		1
A008	SUPPORTER, HOLDER	4980ED2018A		1
A010	CABINET	WB	3090ED1001D	1
		BB	3090ED1001E	1
		ST	3090ED1001F	1
A020	CABINET	WB	3090ED1002D	1
		BB	3090ED1002E	1
		ST	3090ED1002F	1
A040	COVER ASSEMBLY, LOWER	WB	3551DD2001A	1
		BB	3551DD2001B	1
		ST	3551DD2001C	1
A050	NOZZLE ASSEMBLY	5249DD1002A	LOWER NOZZLE	1
A060	NOZZLE ASSEMBLY	5249DD1001A	UPPER NOZZLE	1
A070	GUIDE ASSEMBLY	4974DD9001A		1
A073	WASHER, DRAWING	1WZZDD3001A		1
A074	SHAFT, NOZZLE	4370ED3007A		1
A080	RACK	3750DD2001A	CUP RACK	2
A101	DECO HANDLE	3806DD3004A	STS	1
A102	HANDLE FRONT	3650DD3001A	FRONT	1
A103	HANDLE REAR	3650DD3002A	REAR	1
A110	BASKET ASSEMBLY, SPOON	5005DD1001A		1
A120	HARNESS, PWB	6877DD1002A		1
A130	HOSE ASSEMBLY, DRAIN	5215ED3001E		1
A140	RACK ASSEMBLY	3751DD1006A	LOWER RACK	1
A141	RACK	3750DD1007A		1
A142	ROLLER ASSEMBLY	4581DD9002B		8
A144	RACK	3750DD2003A		2
A147	HOLDER	4930DD3006A		3
A150	RACK ASSEMBLY	3751DD1005A	UPPER RACK	1
A151	RACK	3751DD1005A		1
A152	ROLLER ASM	4581DD3002A		10
A158	HOLDER	4930DD3005A		3
A160	FILTER ASSEMBLY (CIRC)	6201EC1006A		1
E010	BUSHING	4830ED4001A		2
F001	FRAME ASSEMBLY	3211DD1001A		1
F004	NOZZLE ASSEMBLY	5249DD2001A	TOP NOZZLE	1
F005	SHAFT NOZZLE	4370ED3006A	TOP NOZZLE	1

No.	PART NAME		PART No.	SPEC&COLOR	Q'ty
F011	SPRING, HINGE		4970ED4004A		2
F013	CONNECTOR ASSEMBLY		4933DD3001A		2
F014	HINGE, BRACKET		4810ED4004A		2
F022	SENSOR ASSEMBLY		6501DD2001A		1
F040	GUIDE ASSEMBLY		4975DD1001A		1
F041	HOSE, INLET		5214DD3001A		1
F042	HOSE, CONNECTOR		5214DD3003A		1
F043	HOSE, CONNECTOR		5214DD3002A		1
F045	COVER, PROTECT		3550DD2001A		1
F050	NUT, DRAWING		4020FD3641C		1
F060	GASKET		4986DD3001A		1
F101	PACKING		3920DD3002A		1
F110	RAIL ASSEMBLY		5219DD2002A	MUST CHANGE F117 TOGETHER(REF 24P-13)	1
F013	CONNECTOR ASSEMBLY		4933DD3001A		2
F117	STOPPER, ROLLER		4620ED3001A		2
F132	PACKING		3920DD3005A	TUB PACKING	1
F143	HINGE ASSEMBLY		4775ED3004A		1
F144	HINGE ASSEMBLY		4775ED3003A		1
F171	LATCH, LOCK		4026DD3001A		1
F174	BRACKET, HINGE		3751DD1006A	DOOR FRAME	1
F191	GUIDE, WATER		4974DD2003A		1
F192	GUIDE, NOZZLE		4974DD3001A		1
F210	RAIL ASSEMBLY		5219DD2001A	MUST CHANGE F117 TOGETHER(REF 24P-13)	1
K001	DISPENSER		4924FD2123E		1
K002	BRACKET ASSEMBLY		4810FD3805A		2
K005	HANDLE	WB	3650ED2006A		1
		BB	3650ED2006B		1
		ST	3650ED2006C		1
K006	DECO, HANDLE	WB	3806ED3008A		2
		BB	3806ED3008B		2
		ST	3806ED3008C		2
K010	COVER FRONT	WB	3550ED0001E		1
		BB	3550ED0001F		1
		ST	3550ED0001G		1
K030	COVER ASSEMBLY, FRONT	WB	3551DD1003H		1
		BB	3551DD1003F		1
		ST	3551DD1003G		1
K100	DOOR LINER ASM		4937DD9001A	DOOR LINER + DAMPING SHEET + GASKET	1
K110	BLOWER ASSEMBLY		5835ED2002A		1
K121	GASKET		4986DD3003A	BLOWER GASKET	1
K122	COVER, BLOWER		3550ED3011A		1
K124	VENT		5232ED2001A		1
K141	DOOR HINGE ASSEMBLY		4775DD2001A		1
K142	DOOR HINGE ASSEMBLY		4775DD2002A		1
K201	BUTTON, CONTROL	WB	5020ED3008C	PROGRAM BUTTON	5
		BB	5020ED3008D		5
		ST	5020ED3008R		5
K203	WINDOW	WB	3790ED3007Q	TOP WINDOW	1
		BB	3790ED3007R		1

No.	PART NAME		PART No.	SPEC&COLOR	Q'ty
K203	WINDOW	ST	3790ED3007P		1
K207	COVER, GUIDE		3550ED3012B		1
K208	PANEL, CONTROL	WB	3720ED1005E		1
		BB	3720ED1005F		1
		ST	3720ED1005D		1
K209	BUTTON, POWER SWITCH	WB	5020ED3011A		1
		BB	5020ED3011B		1
		ST	5020ED3011A		1
K215	COVER, GUIDE		3550ED1009B		1
K216	BUTTON, CONTROL	WB	5020ED3012C	OPTION BUTTON	2
		BB	5020ED3012D		2
		ST	5020ED3012E		2
K220	MARK, PET	WB	3846ER1001A		1
		BB	3846ER1001B		1
		ST	3846ER1001A		1
K251	PWB(PCB) ASSEMBLY, MAIN		6871DD1006A		1
K252	PWB(PCB) ASSEMBLY, DISPLAY		6871DD2001A		1
K253	PWB(PCB) ASSEMBLY, DISPLAY		6871DD2002A		1
K260	LATCH, ASSEMBLY		4027ED3002A		1
M001	HOLDER		4930DD3002A		1
M005	GASKET		4986DD3002A	SUMP GASKET	1
M006	SUMP, ASSEMBLY		3485ED1002B		1
M007	SUMP		3485DD1001A	SUMP+SEAL+GREASE	1
M025	VALVE, CHECK		5220DD3001A		1
M026	MOTOR ASSEMBLY, WM		4681ED3001B	VARIO MOTOR	1
M027	SWITCH, MICRO		3W40025C		1
M028	CAM, SWITCH		4430ED3001A		1
M031	PACKING		3920ED4009B	VARIO PACKING	1
M034	BLADE		5832DD4001A		1
M035	SEAL		4036DD3001A		1
M036	HOLDER		4930DD3008A		1
M037	FILTER ASSEMBLY, MESH		5231DD1001A		1
M038	HOLDER		4930DD3012A		1
M050	MOTOR ASSEMBLY, PUMP		4681EA2002D	DRAIN MOTOR	1
M060	MOTOR ASSEMBLY, WM		4681ED1004A		1
M081	HEATER ASSEMBLY		5301DD1001A		1
M086	MICRO S/W		3W40025P		1
M087	SENSOR ASSEMBLY		6501ED2002E	SOIL SENSOR	1
M088	PROTECTOR (MECH)		3740ED3003A		1
M090	FLOAT ASSEMBLY		4769DD2001A		1
M110	FILTER ASSEMBLY, MESH		5231ED1001A		1
M120	CASE ASSEMBLY		3111DD1001A		1
M130	IMPELLER ASSEMBLY		5911ED3003A		1
M210	VALVE ASSEMBLY, INLET		5221DD1001A		1
M220	VALVE, CHECK		5220ED4004A		1
M260	BASE, CABINET		MAM34326301		1
M261	COVER ASSEMBLY, BASE		ACQ31707201		1
M262	CASE		3110DD3002A		1
M270	LEG		4778DD3001A		1
M300	ACCESSORY ASSEMBLY		5001DD2001D	GUIDE ASSY+LEG	1

**CAUTION** : BEFORE REPLACING ANY OF THESE COMPONENTS.  
 READ CAREFULLY THE SAFETY PRECAUTIONS IN THIS MANUAL

■ **NOTE** : S(SAFETY PARTS), AL(ALTERNATIVE PARTS)

LG MODEL: LD-6100(WB, BB, TB)			Run Date : 2007-01-02	
YOUR MODEL: LDF7811(WW, BB, ST) / 01			SPECIFICATION: 120V 60Hz	
LOC	DESC	PART No.	COMMENTS	QTY
*001	Manual Assembly, Owners	3829DD3002B		1
*002	Box, Carton	3890DZ3015A		1
*003	Manual, Service	3828ED3001X		0
*005	Accessory Assembly	5001DD4001A		1
A003	Damper	4766DD2004A	LOWER FELT	1
A005	Bracket, Top	4810DD4002B		2
A006	Supporter, Holder	4980ED2015A		1
A007	Supporter, Holder	4980ED2014A		1
A008	Supporter, Holder	4980ED2018A		1
A010	Cabinet	WB	3090ED1001D	1
		BB	3090ED1001E	1
		ST	3090ED1001F	1
A020	Cabinet	WB	3090ED1002D	1
		BB	3090ED1002E	1
		ST	3090ED1002F	1
A040	Cover Assembly, Lower	WB	3551DD2001A	1
		BB	3551DD2001B	1
		ST	3551DD2001C	1
A050	Nozzle Assembly	AGB32598301	LOWER NOZZLE	1
A060	Nozzle Assembly	5249DD1001A	UPPER NOZZLE	1
A070	Guide Assembly	4975DD1002A		1
A073	Washer, Common	1WZZDD3001A		1
A074	Shaft, Nozzle	4370ED3007A		1
A080	Rack	3750DD2001A	CUP RACK	2
A101	Decor, Handle	3806DD3004A	STS	1
A102	Handle	3650DD3001A	FREONT	1
A103	Handle	3650DD3002A	REAR	1
A110	Basket Assembly, Spoon	5005DD1001A		1
A120	Harness, Multi	6877DD1002C		1
A130	Hose Assembly, Drain	AEM30700301		1
A140	Rack Assembly	3751DD1001A	LOWER RACK	1
A141	Rack	3750ED1004A		1
A142	Roller Assembly	4581DD3003B		8
A144	Rack	3750DD2003A		2
A147	Holder	4930DD3006A		2
A148	Rack	3750DD1001A		1
A149	Rack	3750DD1002A		1
A150	Rack Assembly	3751DD1002A	UPPER RACK	1
A151	Rack	3750ED1005A		1
A155	Guide Assembly	4975ED2005A	RIGHT	1
A156	Guide Assembly	4975ED2004A	LEFT	1
A157	Holder	4930DD3003A		2
A158	Holder	4930DD3005A		2
A159	Rack	3750DD2002A		2
A160	Filter, AC Line	6201EC1006A		1

No.	PART NAME		PART No.	SPEC&COLOR	Q'ty
E010	Bush		4830ED4001A		2
F001	Frame Assembly		3211DD1001A		1
F004	Nozzle Assembly		5249DD2001A	TOP NOZZLE	1
F005	Shaft, Nozzle		4370ED3006A	TOP NOZZLE	1
F011	Spring, Hinge		4970ED4004A		2
F013	Connector Assembly		4933DD3001A		2
F014	Bracket, Hinge		4810ED4004A		2
F022	Sensor Assembly		6501DD2001A		1
F040	Guide Assembly		4975DD1001A		1
F041	Hose, Inlet		5214DD3001A		1
F042	Hose, Connector		5214DD3003A		1
F043	Hose, Connector		5214DD3002A		1
F045	Cover, Protect		3550DD2001A		1
F050	Nut, Common		4020FD3641C		1
F060	Gasket		4986DD3001A		1
F101	Packing		3920DD3002A		1
F110	Rail Assembly		5219DD2002A		1
F117	Stopper, Roller		4620ED3001A		2
F132	Packing		3920DD3005A	TUB PACKING	1
F143	Hinge Assembly		4775ED3004A		1
F144	Hinge Assembly		4775ED3003A		1
F171	Locker, Lock		4026DD3001A		1
F174	Bracket, Hinge		4810DD1001A	DOOR FRAME	1
F191	Guide, Water		MEA36937101		1
F192	Guide, Nozzle		4974DD3001A		1
F210	Rail Assembly		5219DD2001A		1
K001	Dispenser		4924FD2123E		1
K002	Bracket Assembly		4810FD3805A		2
K005	Handle	WB	3650ED2006A		1
		BB	3650ED2006B		1
		ST	3650ED2006E		1
K006	Decor, Handle	WB	3806ED3008A		2
		BB	3806ED3008B		2
		ST	3806ED3008C		2
K010	Cover, Front	WB	3550ED0001A		1
		BB	3550ED0001B		1
		ST	3550ED0001C		1
K030	Cover Assembly, Front	WB	3551DD1003A		1
		BB	3551DD1003B		1
		ST	3551DD1003C		1
K100	Door Liner Assembly		4937DD1001B	DOORLINER+DAMPING SHEET+GASKET	1
K110	Casing Assembly		5835ED2002D		1
K121	Gasket		4986DD3003A	BLOWER GASKET	1
K122	Cover, Blower		3550ED3011A		1
K124	Vent		MJZ36939301		1
K141	DOOR HONGE ASSEMBLY		4775DD2001A		1
K142	DOOR HONGE ASSEMBLY		4775DD2002A		1
K201	Button, Control	WB	5020ED3008C	PROGRAM BUTTON	6
		BB	5020ED3008D		6
		ST	5020ED3008E		6
K203	Window	WB	3790ED3007A		1
		BB	3790ED3007D		1

No.	PART NAME		PART No.	SPEC&COLOR	Q'ty
K203	Window	ST	3790ED3007E		1
K207	Cover, Guide		3550ED3012A		1
K208	Panel, Control	WB	3720ED1005A		1
		BB	3720ED1005B		1
		ST	3720ED1005C		1
K209	Button, Power Switch	WB	5020ED3011A		1
		BB	5020ED3011B		1
		ST	5020ED3011C		1
K215	Cover, Guide		3550ED1009A		1
K216	Button, Control	WB	5020ED3012C	OPTION BUTTON	4
		BB	5020ED3012D		4
		ST	5020ED3012E		4
K220	Name Plate, Pet	WB	3846ER1001A		1
		BB	3846ER1001B		1
		ST	3846ER1001A		1
K230	Window Assembly	WB	3791DD3001A	FRONT WINDOW	1
		BB	3791DD3001B		1
		ST	3791DD3001B		1
K251	PCB Assembly, Main		6871DD1006J		1
K252	PCB Assembly		6871DD2001A		2
K253	PCB Assembly		6871DD2002A		2
K254	LED Display Module		6327DC3001A		1
K260	Locker Assembly		4027ED3002A		1
M001	Holder		4930DD3002A		1
M005	Gasket		4986DD3002A	SUMP GASKET	1
M006	Sump Assembly		AJH31248601		1
M007	Sump Assembly		AJH32598001	SUMP+SEALGREASE	1
M025	Valve, Check		MJX32862501		1
M026	Motor Assembly, AC, Fan		4681ED3001B	VARIO MOTOR	1
M027	Switch, Micro		3W40025C		1
M028	Cam, Switch		MBJ32856401		1
M031	Packing		3920ED4009B	VARIO PACKING	1
M034	Blade		5832DD4001A		1
M035	Gasket		MFZ32863101		1
M036	Holder		4930DD3008A		2
M038	Holder		4930DD3012A		1
M050	Motor Assembly, AC, Pump		4681EA2002D	DRAIN MOTOR	1
M060	Motor Assembly, DC, Washer		4681ED1004A		1
M081	Heater Assembly		5301DD1001A		1
M086	Switch, Micro		3W40025P		2
M087	Sensor Assembly		6501ED2002F	SOIL SENSOR	1
M088	Cover		3740ED3003A		1
M090	Float Assembly		4769DD2001A		1
M110	Filter Assembly, Mesh		ADQ32598201		1
M120	Case Assembly		ABQ32598101		1
M130	Impeller Assembly		5911ED3003A		1
M210	Valve Assembly, Inlet		5221DD1001A		1
M220	Valve, Check		5220ED4004A		1
M221	COVER		MCK32863301		1
M260	Base, Cabinet		MAM34326301		1
M261	Cover Assembly, Base		ACQ31707201		1
M262	Case		3110DD3002A		1
M270	Leg		4778DD3001A		4
M300	ACCESSORY ASSEMBLY		5001DD2001C	GUIDE ASSY	1

**CAUTION** : BEFORE REPLACING ANY OF THESE COMPONENTS.  
 READ CAREFULLY THE SAFETY PRECAUTIONS IN THIS MANUAL

■ **NOTE** : **S**(SAFETY PARTS), **AL**(ALTERNATIVE PARTS)

LG MODEL: LD-6090(WB,BB,TB)			Run Date : 2007-01-02	
YOUR MODEL: LDS5811(WW,BB,ST) / 01			SPECIFICATION: 120V 60Hz	
LOC	DESC	PART No.	COMMENTS	QTY
*001	Manual Assembly, Owners	3829DD3002c		1
*002	Box, Carton	3890DZ3015A		1
*003	Manual, Service	3828ED3001X		0
*005	Accessory Assembly	5001DD4001A		1
A003	Damper	4766DD2004A	LOWER FELT	1
A005	Bracket, Top	4810DD4002B		2
A006	Supporter, Holder	4980ED2015A		1
A007	Supporter, Holder	4980ED2014A		1
A008	Supporter, Holder	4980ED2018A		1
A010	Cabinet	WB	3090ED1001D	1
		BB	3090ED1001E	1
		ST	3090ED1001F	1
A020	Cabinet	WB	3090ED1002D	1
		BB	3090ED1002E	1
		ST	3090ED1002F	1
A040	Cover Assembly, Lower	WB	3551DD2001A	1
		BB	3551DD2001B	1
		ST	3551DD2001C	1
A050	Nozzle Assembly	AGB32598301	LOWER NOZZLE	1
A060	Nozzle Assembly	5249DD1001A	UPPER NOZZLE	1
A070	Guide Assembly	4975DD1002A		1
A073	Washer, Common	1WZZDD3001A		1
A074	Shaft, Nozzle	4370ED3007A		1
A080	Rack	3750DD2001A	CUP RACK	2
A101	Decor, Handle	3806DD3004A	STS	1
A102	Handle	3650DD3001A	FREONT	1
A103	Handle	3650DD3002A	REAR	1
A110	Basket Assembly, Spoon	5005DD1001A		1
A120	Harness, Multi	6877DD1002C		1
A130	Hose Assembly, Drain	AEM30700301		1
A140	Rack Assembly	3751DD1001A	LOWER RACK	1
A141	Rack	3750ED1004A		1
A142	Roller Assembly	4581DD3003B		8
A144	Rack	3750DD2003A		2
A147	Holder	4930DD3006A		2
A148	Rack	3750DD1001A		1
A149	Rack	3750DD1002A		1
A150	Rack Assembly	3751DD1002B	UPPER RACK	1
A151	Rack	3750ED1005B		1
A152	Roller Assembly	4581DD3002A		10
A157	Holder	4930DD3003A		2
A158	Holder	4930DD3005A		2
A159	Rack	3750DD2002A	TINE FOLD DOWN	1
A160	Filter, AC Line	6201EC1006A		1
E010	Bush	4830ED4001A		2

No.	PART NAME		PART No.	SPEC&COLOR	Q'ty
F001	Frame Assembly		3211DD1001A		1
F004	Nozzle Assembly		5249DD2001A	TOP NOZZLE	1
F005	Shaft, Nozzle		4370ED3006A	TOP NOZZLE	1
F011	Spring, Hinge		4970ED4004A		2
F013	Connector Assembly		4933DD3001A		2
F014	Bracket, Hinge		4810ED4004A		2
F022	Sensor Assembly		6501DD2001A		1
F040	Guide Assembly		4975DD1001A		1
F041	Hose, Inlet		5214DD3001A		1
F042	Hose, Connector		5214DD3003A		1
F043	Hose, Connector		5214DD3002A		1
F045	Cover, Protect		3550DD2001A		1
F050	Nut, Common		4020FD3641C		1
F060	Gasket		4986DD3001A		1
F101	Packing		3920DD3002A		1
F110	Rail Assembly		5219DD2002A		1
F117	Stopper, Roller		4620ED3001A		2
F132	Packing		3920DD3005A	TUB PACKING	1
F143	Hinge Assembly		4775ED3004A		1
F144	Hinge Assembly		4775ED3003A		1
F171	Locker, Lock		4026DD3001A		1
F174	Bracket, Hinge		4810DD1001A	DOOR FRAME	1
F191	Guide, Water		MEA36937101		1
F192	Guide, Nozzle		4974DD3001A		1
F210	Rail Assembly		5219DD2001A		1
K001	Dispenser		4924FD2123E		1
K002	Bracket Assembly		4810FD3805A		2
K010	Cover, Front	WB	3550DD1004A		1
		BB	3550DD1004B		1
		ST	3550DD1004D		1
K100	Door Liner Assembly		4937DD1001B	DOORLINER+DAMPING SHEET+GASKET	1
K110	Casing Assembly		5835ED2002D		1
K121	Gasket		4986DD3003A	BLOWER GASKET	1
K122	Cover, Blower		3550ED3011A		1
K124	Vent		MJZ36939301		1
K141	DOOR HONGE ASSEMBLY		4775DD2001A		1
K142	DOOR HONGE ASSEMBLY		4775DD2002A		1
K201	Button, Control	WB	5020DD2001A	PROGRAM BUTTON	6
		BB	5020DD2001B		6
		ST	5020DD2001C		6
K203	Window	WB	3790DD3001A	PROGRESS WINDOW	1
		BB	3790DD3001B		1
		ST	3790DD3001C		1
K208	Panel, Control	WB	3720DD1001A		1
		BB	3720DD1001B		1
		ST	3720DD1001C		1
K209	Button, Power Switch	WB	5020DD2004A		1
		BB	5020DD2004B		1
		ST	5020DD2004C		1

No.	PART NAME	PART No.	SPEC&COLOR	Q'ty
K212	Button, Control	5020DD3001A		1
K216	Button, Control	WB	5020DD2003A	1
		BB	5020DD2003B	1
		ST	5020DD2003C	1
K217	Button, Control	WB	5020DD2002A	1
		BB	5020DD2002B	1
		ST	5020DD2002C	1
K220	Name Plate, Pet	WB	3846ER1001A	1
		BB	3846ER1001B	1
		ST	3846ER1001C	1
K230	Window	3790DD3002A		1
K251	PCB Assembly, Main	6871DD1006K		1
K252	PCB Assembly, Display	6871DD2003A		1
K260	Locker Assembly	4027ED3002A		1
K262	Handle	WB	3650DD2005A	1
		BB	3650DD2005B	1
		ST	3650DD2005C	1
M001	Holder	4930DD3002A		1
M005	Gasket	4986DD3002A	SUMP GASKET	1
M006	Sump Assembly	AJH31248601		1
M007	Sump Assembly	AJH32598001	SUMP+SEALGREASE	1
M025	Valve, Check	MJX32862501		1
M026	Motor Assembly, AC, Fan	4681ED3001B	VARIO MOTOR	1
M027	Switch, Micro	3W40025C		1
M028	Cam, Switch	MBJ32856401		1
M031	Packing	3920ED4009B	VARIO PACKING	1
M034	Blade	5832DD4001A		1
M035	Gasket	MFZ32863101		1
M036	Holder	4930DD3008A		2
M038	Holder	4930DD3012A		1
M050	Motor Assembly, AC, Pump	4681EA2002D	DRAIN MOTOR	1
M060	Motor Assembly, DC, Washer	4681ED1004A		1
M081	Heater Assembly	5301DD1001A		1
M086	Switch, Micro	3W40025P		2
M087	Sensor Assembly	6501ED2002F	SOIL SENSOR	1
M088	Cover	3740ED3003A		1
M090	Float Assembly	4769DD2001A		1
M110	Filter Assembly, Mesh	ADQ32598201		1
M120	Case Assembly	ABQ32598101		1
M130	Impeller Assembly	5911ED3003A		1
M210	Valve Assembly, Inlet	5221DD1001A		1
M220	Valve, Check	5220ED4004A		1
M221	COVER	MCK32863301		1
M260	Base, Cabinet	MAM34326301		1
M261	Cover Assembly, Base	ACQ31707201		1
M262	Case	3110DD3002A		1
M270	Leg	4778DD3001A		4
M300	ACCESSORY ASSEMBLY	5001DD2001C	GUIDE ASSY	1

**CAUTION** : BEFORE REPLACING ANY OF THESE COMPONENTS.  
 READ CAREFULLY THE SAFETY PRECAUTIONS IN THIS MANUAL

■ **NOTE** : S(SAFETY PARTS), AL(ALTERNATIVE PARTS)

LG MODEL: LD-6105(WB, BB, TB)			Run Date : 2007-01-02	
YOUR MODEL: LDS7810(WW, BB, ST) / 01			SPECIFICATION: 120V 60Hz	
LOC	DESC	PART No.	COMMENTS	QTY
*001	Manual Assembly, Owners	3829DD3002B		1
*002	Box, Carton	3890DZ3015A		1
*003	Manual, Service	3828ED3001X		0
*005	Accessory Assembly	5001DD4001A		1
A003	Damper	4766DD2004A	LOWER FELT	1
A005	Bracket, Top	4810DD4002B		2
A006	Supporter, Holder	4980ED2015A		1
A007	Supporter, Holder	4980ED2014A		1
A008	Supporter, Holder	4980ED2018A		1
A010	Cabinet	WB	3090ED1001D	1
		BB	3090ED1001E	1
		ST	3090ED1001F	1
A020	Cabinet	WB	3090ED1002D	1
		BB	3090ED1002E	1
		ST	3090ED1002F	1
A040	Cover Assembly, Lower	WB	3551DD2001A	1
		BB	3551DD2001B	1
		ST	3551DD2001C	1
A050	Nozzle Assembly	AGB32598301	LOWER NOZZLE	1
A060	Nozzle Assembly	5249DD1001A	UPPER NOZZLE	1
A070	Guide Assembly	4975DD1002A		1
A073	Washer, Common	1WZZDD3001A		1
A074	Shaft, Nozzle	4370ED3007A		1
A080	Rack	3750DD2001A	CUP RACK	2
A101	Decor, Handle	3806DD3004A	STS	1
A102	Handle	3650DD3001A	FREONT	1
A103	Handle	3650DD3002A	REAR	1
A110	Basket Assembly, Spoon	5005DD1001A		1
A120	Harness, Multi	6877DD1002C		1
A130	Hose Assembly, Drain	AEM30700301		1
A140	Rack Assembly	3751DD1001A	LOWER RACK	1
A141	Rack	3750ED1004A		1
A142	Roller Assembly	4581DD3003B		8
A144	Rack	3750DD2003A		2
A147	Holder	4930DD3006A		2
A148	Rack	3750DD1001A		1
A149	Rack	3750DD1002A		1
A150	Rack Assembly	3751DD1002A	UPPER RACK	1
A151	Rack	3750ED1005A		1
A155	Guide Assembly	4975ED2005A	RIGHT	1
A156	Guide Assembly	4975ED2004A	LEFT	1
A157	Holder	4930DD3003A		2
A158	Holder	4930DD3005A		2
A159	Rack	3750DD2002A		2
A160	Filter, AC Line	6201EC1006A		1

No.	PART NAME		PART No.	SPEC&COLOR	Q'ty
E010	Bushing		4830ED4001A		2
F001	Frame Assembly		3211DD1001A		1
F004	Nozzle Assembly		5249DD2001A	TOP NOZZLE	1
F005	Shaft, Nozzle		4370ED3006A	TOP NOZZLE	1
F011	Spring, Hinge		4970ED4004A		2
F013	Connector Assembly		4933DD3001A		2
F014	Bracket, Hinge		4810ED4004A		2
F022	Sensor Assembly		6501DD2001A		1
F040	Guide Assembly		4975DD1001A		1
F041	Hose, Inlet		5214DD3001A		1
F042	Hose, Connector		5214DD3003A		1
F043	Hose, Connector		5214DD3002A		1
F045	Cover, Protect		3550DD2001A		1
F050	Nut, Common		4020FD3641C		1
F060	Gasket		4986DD3001A		1
F101	Packing		3920DD3002A		1
F110	Rail Assembly		5219DD2002A		1
F013	Connector Assembly		4933DD3001A		2
F117	Stopper, Roller		4620ED3001A		2
F132	Packing		3920DD3005A	TUB PACKING	1
F143	Hinge Assembly		4775ED3004A		1
F144	Hinge Assembly		4775ED3003A		1
F171	Locker, Lock		4026DD3001A		1
F174	Bracket, Hinge		4810DD1001A	DOOR FRAME	1
F191	Guide, Water		MEA36937101		1
F192	Guide, Nozzle		4974DD3001A		1
F210	Rail Assembly		5219DD2001A		1
K001	Dispenser		4924FD2123E		1
K002	Bracket Assembly		4810FD3805A		2
K005	Handle	WB	3650ED2006A		1
		BB	3650ED2006B		1
		ST	3650ED2006E		1
K006	Decor, Handle	WB	3806ED3008A		2
		BB	3806ED3008B		2
		ST	3806ED3008C		2
K010	Cover, Front	WB	3550ED0001E		1
		BB	3550ED0001F		1
		ST	3550ED0001G		1
K030	Cover Assembly, Front	WB	3551DD1001E/H		1
		BB	3551DD1003F		1
		ST	3551DD1003G		1
K100	Door Liner Assembly		4937DD1001B	DOORLINER+DAMPING SHEET+GASKET	1
K110	Casing Assembly		5835ED2002D		1
K121	Gasket		4986DD3003A	BLOWER GASKET	1
K122	Cover, Blower		3550ED3011A		1
K124	Vent		MJZ36939301		1
K141	DOOR HONGE ASSEMBLY		4775DD2001A		1
K142	DOOR HONGE ASSEMBLY		4775DD2002A		1
K201	Button, Control	WB	5020ED3008C	PROGRAM BUTTON	6
		BB	5020ED3008D		6
		ST	5020ED3008E		6

No.	PART NAME	PART No.	SPEC&COLOR	Q'ty
K203	Window	WB	3790ED3007C	1
		BB	3790ED3007D	1
		ST	3790ED3007E	1
K207	Cover, Guide		3550ED3012A	1
K208	Panel, Control	WB	3720ED1005A	1
		BB	3720ED1005B	1
		ST	3720ED1005C	1
K209	Button, Power Switch	WB	5020ED3011A	1
		BB	5020ED3011B	1
		ST	5020ED3011C	1
K215	Cover, Guide		3550ED1009A	1
K216	Button, Control	WB	5020ED3012C	4
		BB	5020ED3012D	4
		ST	5020ED3012E	4
K220	Name Plate, Pet	WB	3846ER1001A	1
		BB	3846ER1001B	1
		ST	3846ER1001A	1
K251	PCB Assembly, Main		6871DD1006L	1
K252	PCB Assembly		6871DD2001B	2
K253	PCB Assembly		6871DD2002A	2
K260	Locker Assembly		4027ED3002A	1
M001	Holder		4930DD3002A	1
M005	Gasket		4986DD3002A	1
M006	Sump Assembly		AJH31248601	1
M007	Sump Assembly		AJH32598001	1
M025	Valve, Check		MJX32862501	1
M026	Motor Assembly, AC, Fan		4681ED3001B	1
M027	Switch, Micro		3W40025C	1
M028	Cam, Switch		MBJ32856401	1
M031	Packing		3920ED4009B	1
M034	Blade		5832DD4001A	1
M035	Gasket		MFZ32863101	1
M036	Holder		4930DD3008A	2
M037	Filter Assembly, Mesh		5231DD1001A	1
M038	Holder		4930DD3012A	1
M050	Motor Assembly, AC, Pump		4681EA2002D	1
M060	Motor Assembly, DC, Washer		4681ED1004A	1
M081	Heater Assembly		5301DD1001A	1
M086	Switch, Micro		3W40025P	2
M087	Sensor Assembly		6501ED2002F	1
M088	Cover		3740ED3003A	1
M090	Float Assembly		4769DD2001A	1
M110	Filter Assembly, Mesh		ADQ32598201	1
M120	Case Assembly		ABQ32598101	1
M130	Impeller Assembly		5911ED3003A	1
M210	Valve Assembly, Inlet		5221DD1001A	1
M220	Valve, Check		5220ED4004A	1
M221	COVER		MCK32863301	1
M260	Base, Cabinet		MAM34326301	1
M261	Cover Assembly, Base		ACQ31707201	1
M262	Case		3110DD3002A	1
M270	Leg		4778DD3001A	4
M300	ACCESSORY ASSEMBLY		5001DD2001C	1

**CAUTION** : BEFORE REPLACING ANY OF THESE COMPONENTS.  
 READ CAREFULLY THE SAFETY PRECAUTIONS IN THIS MANUAL

■ **NOTE** : S(SAFETY PARTS), AL(ALTERNATIVE PARTS)

LG MODEL: LD-6300(WB,BB,TB)			Run_Date : 2007-01-02	
YOUR MODEL: LDF6810(WW,BB,ST) / 01			SPECIFICATION: 120V 60Hz	
LOC	DESC	PART No.	COMMENTS	QTY
*001	Manual Assembly, Owners	3829DD3005M		1
*002	Box, Carton	3890DZ3015A		1
*003	Manual, Service	3828ED3001X		0
*005	Accessory Assembly	5001DD4001A		1
A003	Damper	4766DD2004A	LOWER FELT	1
A005	Bracket, Top	4810DD4002B		2
A006	Supporter, Holder	4980ED2015A		1
A007	Supporter, Holder	4980ED2014A		1
A008	Supporter, Holder	4980ED2018A		1
A010	Cabinet	WB	3090ED1001D	1
		BB	3090ED1001E	1
		ST	3090ED1001F	1
A020	Cabinet	WB	3090ED1002D	1
		BB	3090ED1002E	1
		ST	3090ED1002F	1
A040	Cover Assembly, Lower	WB	3551DD2001A	1
		BB	3551DD2001B	1
		ST	3551DD2001C	1
A050	Nozzle Assembly	AGB32598301	LOWER NOZZLE	1
A060	Nozzle Assembly	5249DD1001A	UPPER NOZZLE	1
A070	Guide Assembly	4975DD1002A		1
A073	Washer, Common	1WZZDD3001A		1
A074	Shaft, Nozzle	4370ED3007A		1
A080	Rack	3750DD2001A	CUP RACK	2
A101	Decor, Handle	3806DD3004A	STS	1
A102	Handle	3650DD3001A	FREONT	1
A103	Handle	3650DD3002A	REAR	1
A110	Basket Assembly, Spoon	5005DD1001A		1
A120	Harness, Multi	6877DD1002C		1
A130	Hose Assembly, Drain	AEM30700301		1
A140	Rack Assembly	3751DD1006A	LOWER RACK	1
A141	Rack	3750DD1007A		1
A142	Roller Assembly	4581DD3003B		8
A144	Rack	3750DD2003A		2
A147	Holder	4930DD3006A		2
A150	Rack Assembly	3751DD1002A	UPPER RACK	1
A151	Rack	3750ED1005A		1
A152	Roller Assembly	4581DD3002A		10
A158	Holder	4930DD3005A		2
A160	Filter, AC Line	6201EC1006A		1
E010	Bush	4830ED4001A		2
F001	Frame Assembly	3211DD1001A		1
F004	Nozzle Assembly	5249DD2001A	TOP NOZZLE	1
F005	Shaft, Nozzle	4370ED3006A	TOP NOZZLE	1

No.	PART NAME		PART No.	SPEC&COLOR	Q'ty
F011	Spring, Hinge		4970ED4004A		2
F013	Connector Assembly		4933DD3001A		2
F014	Bracket, Hinge		4810ED4004A		2
F022	Sensor Assembly		6501DD2001A		1
F040	Guide Assembly		4975DD1001A		1
F041	Hose, Inlet		5214DD3001A		1
F042	Hose, Connector		5214DD3003A		1
F043	Hose, Connector		5214DD3002A		1
F045	Cover, Protect		3550DD2001A		1
F050	Nut, Common		4020FD3641C		1
F060	Gasket		4986DD3001A		1
F101	Packing		3920DD3002A		1
F110	Rail Assembly		5219DD2002A		1
F013	Connector Assembly		4933DD3001A		2
F117	Stopper, Roller		4620ED3001A		2
F132	Packing		3920DD3005A	TUB PACKING	1
F143	Hinge Assembly		4775ED3004A		1
F144	Hinge Assembly		4775ED3003A		1
F171	Locker, Lock		4026DD3001A		1
F174	Bracket, Hinge		4810DD1001A	DOOR FRAME	1
F191	Guide, Water		MEA36937101		1
F192	Guide, Nozzle		4974DD3001A		1
F210	Rail Assembly		5219DD2001A		1
K001	Dispenser		4924FD2123E		1
K002	Bracket Assembly		4810FD3805A		2
K005	Handle	WB	3650ED2006A		1
		BB	3650ED2006B		1
		ST	3650ED2006E		1
K006	Decor, Handle	WB	3806ED3008A		2
		BB	3806ED3008B		2
		ST	3806ED3008C		2
K010	Cover, Front	WB	3550ED0001E		1
		BB	3550ED0001F		1
		ST	3550ED0001G		1
K030	Cover Assembly, Front	WB	3551DD1001E/H		1
		BB	3551DD1003F		1
		ST	3551DD1003G		1
K100	Door Liner Assembly		4937DD1001B	DOORLINER+DAMPING SHEET+GASKET	1
K110	Casing Assembly		5835ED2002D		1
K121	Gasket		4986DD3003A	BLOWER GASKET	1
K122	Cover, Blower		3550ED3011A		1
K124	Vent		MJZ36939301		1
K141	DOOR HONGE ASSEMBLY		4775DD2001A		1
K142	DOOR HONGE ASSEMBLY		4775DD2002A		1
K201	Button, Control	WB	5020ED3008C	PROGRAM BUTTON	6
		BB	5020ED3008D		6
		ST	5020ED3008E		6
K203	Window	WB	3790ED3007Q		1
		BB	3790ED3007R		1

No.	PART NAME		PART No.	SPEC&COLOR	Q'ty
		ST	3790ED3007P		1
K207	Cover, Guide		3550ED3012A		1
K208	Panel, Control	WB	3720ED1005E		1
		BB	3720ED1005F		1
		ST	3720ED1005D		1
K209	Button, Power Switch	WB	5020ED3011A		1
		BB	5020ED3011B		1
		ST	5020ED3011C		1
K215	Cover, Guide		3550ED1009A		1
K216	Button, Control	WB	5020ED3012C	OPTION BUTTON	4
		BB	5020ED3012D		4
		ST	5020ED3012E		4
K220	Name Plate, Pet	WB	3846ER1001A		1
		BB	3846ER1001B		1
		ST	3846ER1001A		1
K251	PCB Assembly, Main		6871DD1006M		1
K252	PCB Assembly		6871DD2001F		2
K253	PCB Assembly		6871DD2002D		2
K260	Locker Assembly		4027ED3002A		1
M001	Holder		4930DD3002A		1
M005	Gasket		4986DD3002A	SUMP GASKET	1
M006	Sump Assembly		AJH31248601		1
M007	Sump Assembly		AJH32598001	SUMP+SEALGREASE	1
M025	Valve, Check		MJX32862501		1
M026	Motor Assembly, AC, Fan		4681ED3001B	VARIO MOTOR	1
M027	Switch, Micro		3W40025C		1
M028	Cam, Switch		MBJ32856401		1
M031	Packing		3920ED4009B	VARIO PACKING	1
M034	Blade		5832DD4001A		1
M035	Gasket		MFZ32863101		1
M036	Holder		4930DD3008A		2
M037	Filter Assembly, Mesh		5231DD1001A		1
M038	Holder		4930DD3012A		1
M050	Motor Assembly, AC, Pump		4681EA2002D	DRAIN MOTOR	1
M060	Motor Assembly, DC, Washer		4681ED1004A		1
M081	Heater Assembly		5301DD1001A		1
M086	Switch, Micro		3W40025P		2
M087	Sensor Assembly		6501ED2002F	SOIL SENSOR	1
M088	Cover		3740ED3003A		1
M090	Float Assembly		4769DD2001A		1
M110	Filter Assembly, Mesh		ADQ32598201		1
M120	Case Assembly		ABQ32598101		1
M130	Impeller Assembly		5911ED3003A		1
M210	Valve Assembly, Inlet		5221DD1001A		1
M220	Valve, Check		5220ED4004A		1
M221	COVER		MCK32863301		1
M260	Base, Cabinet		MAM34326301		1
M261	Cover Assembly, Base		ACQ31707201		1
M262	Case		3110DD3002A		1
M270	Leg		4778DD3001A		4
M300	ACCESSORY ASSEMBLY		5001DD2001C	GUIDE ASSY	1

**CAUTION** : BEFORE REPLACING ANY OF THESE COMPONENTS.  
 READ CAREFULLY THE SAFETY PRECAUTIONS IN THIS MANUAL

■ **NOTE** : S(SAFETY PARTS), AL(ALTERNATIVE PARTS)

LG MODEL: LD-6310TB			Run Date : 2007-01-02	
YOUR MODEL: LDF8812ST			SPECIFICATION: 120V 60Hz	
LOC	DESC	PART No.	COMMENTS	QTY
*001	MANUAL ASSEMBLY, OWNERS	AFN31666707		1
*002	BOX, CARTON	3890DZ3015A		1
*003	MANUAL, SERVICE	3828ED3001X		0
*005	ACCESSORY ASSEMBLY	5001DD4001A		1
*007	GUIDE ASSEMBLY	4975DD2001B	RIGHT	1
*008	GUIDE ASSEMBLY	4975DD2002B	LEFT	1
A003	DAMPER	4766DD2004A		1
A005	BRACKET, TOP	4810DD4002B		2
A006	SUPPORTER, HOLDER	4980ED2015A		1
A007	SUPPORTER, HOLDER	4980ED2014A		1
A008	SUPPORTER, HOLDER	4980ED2018A		1
A010	CABINET	3090ED1001F		1
A020	CABINET ASSEMBLY	3091DD1001F		1
A040	COVER ASSEMBLY, LOWER	3551DD2001D		1
A050	NOZZLE ASSEMBLY	5249DD1002A		1
A060	NOZZLE ASSEMBLY	5249DD1001A	LOWER NOZZLE	1
A070	GUIDE ASSEMBLY	4975DD1002A	UPPER NOZZLE	1
A073	WASHER, COMMON	1WZZDD3001A		1
A074	SHAFT, NOZZLE	4370ED3007A		1
A080	RACK	3750DD2001A	CUP RACK	2
A101	DECOR, HANDLE	3806DD3004A	STS	1
A102	HANDLE	3650DD3001A	FRONT	1
A103	HANDLE	3650DD3002A	REAR	1
A110	BASKET ASSEMBLY,SPOON	5005DD1001A		1
A120	HARNESS, MULTI	EAD35070401		1
A130	HOSE ASSEMBLY, DRAIN	AEM30700301	INNER PHI 15, 21	1
A140	RACK ASSEMBLY	3751DD1001A	LOWER RACK	1
A141	RACK	3750ED1004A		1
A142	ROLLER ASSEMBLY	4581DD3003B		8
A144	RACK	3750DD2003A		2
A147	HOLDER	4930DD3006A		2
A148	RACK	3750DD1001A		1
A149	RACK	3750DD1002A		1
A150	RACK ASSEMBLY	3751DD1002C	UPPER RACK	1
A151	RACK	3750ED1005A		1
A155	GUIDE ASSEMBLY	AEC32598701	RIGHT	1
A156	GUIDE ASSEMBLY	AEC32598601	LEFT	1
A157	HOLDER	4930DD3003A		2
A158	HOLDER	4930DD3005A		2
A159	RACK	3750DD2002A		2
A160	FILTER, AC LINE	6201EC1006A		1
E010	BUSH	4830ED4001A		2
F001	FRAME ASSEMBLY	3211DD1001A		1
F004	NOZZLE ASSEMBLY	5249DD2001A	TOP NOZZLE	1
F005	SHAFT, NOZZLE	4370ED3006A	TOP NOZZLE	1

No.	PART NAME	PART No.	SPEC&COLOR	Q'ty
F011	SPRING, HINGE	4970ED4004A		2
F013	CONNECTOR ASSEMBLY	4933DD3001A		2
F014	BRACKET, HINGE	4810ED4004A		2
F022	SENSOR ASSEMBLY	6501DD2001A		1
F040	GUIDE ASSEMBLY	4975DD1001A		1
F041	HOSE, INLET	5214DD3001A		1
F042	HOSE, CONNECTOR	5214DD3003A		1
F043	HOSE, CONNECTOR	5214DD3002A		1
F045	COVER, PROTECT	3550DD2001A		1
F050	NUT, COMMON	4020FD3641C		1
F060	GASKET	4986DD3001A		1
F101	PACKING	3920DD3002A		1
F117	STOPPER, ROLLER	MJB32864101		2
F121	STOPPER, ROLLER	MJB32864101		2
F122	RAIL	MGT32863801		2
F123	HOUSING ASSEMBLY, BEARING	AEN32597901		2
F132	PACKING	3920DD3005A	TUB PACKING	1
F143	HINGE ASSEMBLY	4775ED3004A		1
F144	HINGE ASSEMBLY	4775ED3003A		1
F171	LOCKER, LOCK	4026DD3001A		1
F174	BRACKET, HINGE	4810DD1001A	DOOR FRAME	1
F191	GUIDE, WATER	MEA36937101		1
F192	GUIDE, NOZZLE	4974DD3001A		1
F240	LAMP	6913ER4001B		2
K001	DISPENSER	4924FD2123E		1
K002	BRACKET ASSEMBLY	4810FD3805A		2
K005	HANDLE	3650ED2006E		1
K006	DECOR, HANDLE	3806ED3008C		2
K010	COVER, FRONT	3550ED0001H		1
K030	COVER ASSEMBLY, FRONT	3551DD1003J		1
K100	DOOR LINER ASSEMBLY	4937DD1001B	DOOR LINER + DAMPING SHEET + GASKET	1
K101	DOOR LINER	4936ED1002A		1
K110	CASING ASSEMBLY	5835ED2002D		1
K121	GASKET	4986DD3003A	GBLOWER GASKET	1
K122	COVER, BLOWER	3550ED3011A		1
K124	VENT	MJZ36939301		1
K200	PANEL ASSEMBLY, CONTROL	AGL32598401		1
K207	COVER, GUIDE	MCK34185201		1
K216	BUTTON, CONTROL	MBG32865301		1
K220	NAME PLATE, PET	3846ER1001B		1
K230	WINDOW ASSEMBLY	AJX32598501		1
K260	LOCKER ASSEMBLY	4027ED3002D		1
M001	HOLDER	4930DD3002A		1
M005	GASKET	4986DD3002A	SUMP GASKET	1
M006	SUMP ASSEMBLY	AJH31248601		1
M007	SUMP ASSEMBLY	AJH32598001		1
M025	VALVE, CHECK	MJX32862501		1
M027	SWITCH, MICRO	3W40025C		1
M028	CAM, SWITCH	MBJ32856401		1
M031	PACKING	3920ED4009B	VARIO PACKING	1

No.	PART NAME	PART No.	SPEC&COLOR	Q'ty
M034	BLADE	5832DD4001A		1
M035	PACKING	MFZ32863101		1
M036	HOLDER	4930DD3008A		2
M038	HOLDER	4930DD3012A		1
M050	MOTOR ASSEMBLY, AC	4681EA2002D	DRAIN MOTOR	1
M060	MOTOR ASSEMBLY, DC	4681ED1004A		1
M081	HEATER ASSEMBLY	5301DD1001A		1
M086	SWITCH, MICRO	3W40025P		2
M087	SENSOR ASSEMBLY	6501ED2002F	SOIL SENSOR	1
M088	COVER	3740ED3003A		1
M090	FLOAT ASSEMBLY	4769DD2001A		1
M110	FILTER ASSEMBLY, MESH	ADQ32598201		1
M120	CASE ASSEMBLY	ABQ32598101		1
M130	IMPELLER ASSEMBLY	5911ED3003A		1
M210	VALVE ASSEMBLY, INLET	5221DD1001A		1
M220	VALVE, CHECK	5220DD3002A		1
M221	COVER	MCK32863301		1
M260	BASE,CABINET	MAM34326301		1
M261	COVER ASSEMBLY, BASE	ACQ31707201		1
M262	CASE	3110DD3002A		1
M270	LEG	4778DD3001A		4
M300	ACCESSORY ASSEMBLY	5001DD2001C	GUIDE ASSY	1

**CAUTION** : BEFORE REPLACING ANY OF THESE COMPONENTS.  
 READ CAREFULLY THE SAFETY PRECAUTIONS IN THIS MANUAL

■ **NOTE** : S(SAFETY PARTS), AL(ALTERNATIVE PARTS)

LG MODEL: LD-6090(WB, BB, TB)			Run_Date : 2007-12-03		
YOUR MODEL: LDS5811(WW, BB, ST) / 02			SPECIFICATION: 120V 60Hz		
LOC	DESC	PART No.	COMMENTS	QTY	
*001	MANUAL ASSEMBLY, OWNERS	3829DD3002C		1	
*002	BOX, CARTON	3890DZ3015A		1	
*003	MANUAL, SERVICE	3828ED3001X		0	
*005	ACCESSORY ASSEMBLY	5001DD4001A		1	
*007	GUIDE ASSEMBLY	4975DD2001B		1	
*008	GUIDE ASSEMBLY	4975DD2002B		1	
A003	DAMPER	4766DD2004A		1	
A005	BRACKET, TOP	4810DD4002B		2	
A006	SUPPORTER, HOLDER	4980ED2015A		1	
A007	SUPPORTER, HOLDER	4980ED2014A		1	
A008	SUPPORTER, HOLDER	4980ED2018A		1	
A010	CABINET	WB	3090ED1001D	RIGHT	1
		BB	3090ED1001E		1
		ST	3090ED1001F		1
A020	CABINET ASSEMBLY	WB	3091DD1001D	LEFT	1
		BB	3091DD1001E		1
		ST	3091DD1001F		1
A040	COVER ASSEMBLY, LOWER	WB	3551DD2001A		1
		BB	3551DD2001B		1
		ST	3551DD2001C		1
A050	NOZZLE ASSEMBLY	AGB32598301	LOWER NOZZLE	1	
A060	NOZZLE ASSEMBLY	5249DD1001A	UPPER NOZZLE	1	
A070	GUIDE ASSEMBLY	4975DD1002A	UPPER NOZZLE	1	
A073	WASHER, COMMON	1WZZDD3001A		1	
A074	SHAFT, NOZZLE	4370ED3007A		1	
A080	RACK	3750DD2001A	CUP SHELF	2	
A101	DECOR, HANDLE	3806DD3004A	STS	2	
A102	HANDLE	3650DD3001A	FRONT	2	
A103	HANDLE	3650DD3002A	REAR	2	
A110	BASKET ASSEMBLY, SPOON	5005DD1001A		1	
A120	HARNESS, MULTI	6877DD1002C		1	
A130	HOSE ASSEMBLY, DRAIN	AEM30700301	INNER PHI 15, 21	1	
A140	RACK ASSEMBLY	3751DD1001A	LOWER RACK	1	
A141	RACK	3750ED1004A		1	
A142	ROLLER ASSEMBLY	4581DD3003B		8	
A144	RACK	3750DD2003A		2	
A147	HOLDER	4930DD3006A		2	
A148	RACK	3750DD1001A		1	
A149	RACK	3750DD1002A		1	
A150	RACK ASSEMBLY	3751DD1002B	UPPER RACK	1	
A151	RACK	3750ED1005B		1	
A152	ROLLER ASSEMBLY	4581DD3002A		10	
A157	HOLDER	4930DD3003A		2	
A157	HOLDER	4930DD3003A		2	

No.	PART NAME		PART No.	SPEC&COLOR	Q'ty	
A158	HOLDER		4930DD3005A		2	
A159	RACK		3750DD2002A		1	
A160	FILTER ASSEMBLY		6201EC1006A		1	
A301	SCREW,TAPTITE		1SBF0402418		3	
E010	BUSH		4830ED4001A		2	
F001	FRAME ASSEMBLY		3211DD1001A		1	
F004	NOZZLE ASSEMBLY		5249DD2001A	TOP NOZZLE	1	
F005	SHAFT,NOZZLE		4370ED3006A	TOP NOZZLE	1	
F011	SPRING,HINGE		4970ED4004D		2	
F013	CONNECTOR ASSEMBLY		4933DD3001A		2	
F014	BRACKET,HINGE		4810ED4004A		2	
F022	SENSOR ASSEMBLY		6501DD2001A		1	
F040	GUIDE ASSEMBLY		4975DD1001A		1	
F041	HOSE,INLET		5214DD3001A		1	
F042	HOSE,CONNECTOR		5214DD3003A		1	
F043	HOSE,CONNECTOR		5214DD3002A		1	
F045	COVER,PROTECT		3550DD2001A		1	
F050	NUT,COMMON		4020FD3641C		1	
F060	GASKET		4986DD3001A		1	
F101	PACKING		3920DD3002A		1	
F110	RAIL ASSEMBLY		5219DD2002A		1	
F117	STOPPER,ROLLER		4620ED3001A		2	
F132	PACKING		3920DD3005A	TUB PACKING	1	
F141	HINGE ASSEMBLY		4775DD2002A	DOOR RIGHT	1	
F142	HINGE ASSEMBLY		4775DD2001A	DOOR LEFT	1	
F143	HINGE ASSEMBLY		4775ED3004A	TUB RIGHT	1	
F144	HINGE ASSEMBLY		4775ED3003A	TUB LEFT	1	
F171	LOCKER,LOCK		4026DD3001A		1	
F174	BRACKET,HINGE		4810DD1001A	DOOR FRAME	1	
F191	GUIDE,WATER		MEA36937101		1	
F192	GUIDE,NOZZLE		4974DD3001A		1	
F210	RAIL ASSEMBLY		5219DD2001A		1	
K001	DISPENSER		4924FD2123E		1	
K002	BRACKET ASSEMBLY		4810FD3805A	FIX DISPENSER TO DOOR LINER	2	
K010	COVER,FRONT	WB	3550DD1004A		1	
		BB	3550DD1004B		1	
		ST	3550DD1004D		1	
K100	DOOR LINER ASSEMBLY		4937DD1001C	DOORLINER+CASING+VENT+DISPENSER	1	
K101	PARTS ASSEMBLY		AGM34891601	DOORLINER+DAMPING SHEET+GASKET	1	
K110	CASING ASSEMBLY		ABT35083801	BLOWER	1	
K121	GASKET		4986DD3003A	BLOWER GASKET	1	
K122	COVER,BLOWER		3550ED3011A		1	
K124	VENT		MJZ39902101		1	
K140	HOSE		5214ER4001S	HOSE, NEW BLOWER HOSE ~ BLOWER	1	
K141	CLAMP		4861FR3068M		1	
K200	PANEL ASSEMBLY,CONTROL	WB	AGL32586501		1	
		BB	AGL32586502		1	
		ST	AGL32586503		1	
K201	BUTTON,CONTROL		WB	5020DD2001A	PROGRAM BUTTON LEFT	1

No.	PART NAME		PART No.	SPEC&COLOR	Q'ty
K201	BUTTON,CONTROL	BB	5020DD2001B		1
		ST	5020DD2001C		1
K203	WINDOW	WB	3790DD3001A	PROGRESS WINDOW	1
		BB	3790DD3001B		1
		ST	3790DD3001B		1
K209	BUTTON,CONTROL	WB	5020DD2004A	POWER BUTTON	1
		BB	5020DD2004B		1
		ST	5020DD2004C		1
K212	BUTTON,CONTROL	WB	5020DD3001A	DELAY START BUTTON	1
		BB	5020DD3001A		1
		ST	5020DD3001C		1
K216	BUTTON,CONTROL	WB	5020DD2003A	OPTION BUTTON	1
		BB	5020DD2003B		1
		ST	5020DD2003C		1
K217	BUTTON,CONTROL	WB	5020DD2002A	PROGRAM BUTTON RIGHT	1
		BB	5020DD2002B		1
		ST	5020DD2002C		1
K220	NAME PLATE,PET	WB	3846ER1001A		1
		BB	3846ER1001B		1
		ST	3846ER1001A		1
K230	WINDOW		3790DD3002A		1
K251	PCB ASSEMBLY,MAIN		6871DD1006K		1
K252	PCB ASSEMBLY,DISPLAY		6871DD2003A		1
K260	LOCKER ASSEMBLY		4027ED3002A		1
K262	HANDLE	WB	3650DD2005A		1
		BB	3650DD2005B		1
		ST	3650DD2005D		1
M001	HOLDER		4930DD3002A		1
M005	GASKET		MDS37912401	SUMP GASKET	1
M006	SUMP ASSEMBLY		AJH31248602		2
M007	SUMP		AJH32598001		1
M025	VALVE,CHECK		MJX32862501	VARIO	1
M026	MOTOR ASSEMBLY,AC,DRAIN		4681ED3001B	VARIO MOTOR	1
M027	SWITCH,MICRO		3W40025C	CHECK THE POSITION OF THE VARIO(CAM)	1
M028	CAM,SWITCH		MBJ32856401		1
M031	PACKING		3920ED4009B	VARIO PACKING	1
M034	BLADE		5832DD4001A		1
M035	PACKING		MFZ32863101		1
M036	HOLDER		4930DD3008A	SUMP ASM ~ TUB LOW	2
M038	HOLDER		4930DD3012A	WATER GUIDE ~ SUMP	1
M050	MOTOR ASSEMBLY,AC,PUMP		4681EA2002D	DRAIN MOTOR	1
M060	MOTOR ASSEMBLY,DC		4681ED1004A	WASHING MOTOR	1
M081	HEATER ASSEMBLY		5301DD1001A		1
M086	SWITCH,MICRO		3W40025P		1
M087	SENSOR ASSEMBLY		6501ED2002F	SOIL SENSOR	1
M088	COVER		3740ED3003A	HOLDER HEATER	1
M090	FLOAT ASSEMBLY		4769DD2001A		1
M110	FILTER ASSEMBLY,MESH		ADQ32598201		1
M120	CASE ASSEMBLY		ABQ32598101	PUMP CASE	1
M130	IMPELLER ASSEMBLY		5911ED3003A		1

No.	PART NAME	PART No.	SPEC&COLOR	Q'ty
M210	VALVE ASSEMBLY,INLET	5221DD1001A		0
M220	VALVE,CHECK	5220ED4004A	DRAIN	1
M260	BASE,CABINET	MAM34326301		1
M261	COVER ASSEMBLY,BASE	ACQ31707201		1
M262	CASE	3110DD3002A	JUNCTION BOX	1
M270	LEG	4778DD3001A		4
M300	ACCESSORY ASSEMBLY	5001DD2001D	LEVELING KIT	1
M301	SCREW,CUSTOMIZED	4W51229F	BASE + HINGE SUPPORT	4
M302	SCREW,CUSTOMIZED	1SZZED3005A	SUMP FILTER	8
M303	SCREW,CUSTOMIZED	1SZZED3006A	IMPELLER	1
M304	SCREW,CUSTOMIZED	1SZZFA4305A	SUMP ~ DRAIN PUMP	3
M305	SCREW,CUSTOMIZED	4W51194D	SUMP ~ MOTOR	4

**CAUTION** : BEFORE REPLACING ANY OF THESE COMPONENTS.  
 READ CAREFULLY THE SAFETY PRECAUTIONS IN THIS MANUAL

■ **NOTE** : **S**(SAFETY PARTS), **AL**(ALTERNATIVE PARTS)

LG MODEL: LD-6300(WB,BB,TB)		Run Date : 2007-12-03			
YOUR MODEL: LDF6810(WW,BB,ST)		SPECIFICATION: 120V 60Hz			
LOC	DESC	PART No.	COMMENTS	QTY	
*001	MANUAL ASSEMBLY,OWNERS	3829DD3005M		1	
*002	BOX,CARTON	3890DZ3015A		1	
*003	MANUAL,SERVICE	3828ED3001X		0	
*005	ACCESSORY ASSEMBLY	5001DD4001A		1	
A003	DAMPER	4766DD2004A		1	
A005	BRACKET, TOP	4810DD4002B		2	
A006	SUPPORTER,HOLDER	4980ED2015A		1	
A007	SUPPORTER,HOLDER	4980ED2014A		1	
A008	SUPPORTER,HOLDER	4980ED2018A		1	
A010	CABINET	WB	3090ED1001D	RIGHT	1
		BB	3090ED1001E		1
		ST	3090ED1001F		1
A020	CABINET ASSEMBLY	WB	3091DD1001D	LEFT	1
		BB	3091DD1001E		1
		ST	3091DD1001F		1
A040	COVER ASSEMBLY,LOWER	WB	3551DD2001A		1
		BB	3551DD2001B		1
		ST	3551DD2001C		1
A050	NOZZLE ASSEMBLY	AGB32598301	LOWER NOZZLE	1	
A060	NOZZLE ASSEMBLY	5249DD1001A	UPPER NOZZLE	1	
A070	GUIDE ASSEMBLY	4975DD1002A	UPPER NOZZLE	1	
A073	WASHER,COMMON	1WZZDD3001A		1	
A074	SHAFT,NOZZLE	4370ED3007A		1	
A080	RACK	3750DD2001A	CUP SHELF	2	
A101	DECOR,HANDLE	3806DD3004A	STS	2	
A102	HANDLE	3650DD3001A	FRONT	2	
A103	HANDLE	3650DD3002A	REAR	2	
A110	BASKET ASSEMBLY,SPOON	5005DD1001A		1	
A120	HARNESS,MULTI	6877DD1002C		1	
A130	HOSE ASSEMBLY,DRAIN	AEM30700301	INNER PHI 15, 21	1	
A140	RACK ASSEMBLY	3751DD1006A	LOWER RACK	1	
A141	RACK	3750DD1007A		1	
A142	ROLLER ASSEMBLY	4581DD3003B		8	
A144	RACK	3750DD2003A		2	
A147	HOLDER	4930DD3006A		2	
A150	RACK ASSEMBLY	3751DD1005A	UPPER RACK	1	
A151	RACK	3750DD1006A		1	
A152	ROLLER ASSEMBLY	4581DD3002A		10	
A157	HOLDER	4930DD3003A		2	
A158	HOLDER	4930DD3005A		1	
A160	FILTER ASSEMBLY	6201EC1006A		1	
A301	SCREW,TAPTITE	1SBF0402418		3	
E010	BUSH	4830ED4001A		2	
F001	FRAME,LOWER	3210ED1003A		1	
F004	NOZZLE ASSEMBLY	5249DD2001A	TOP NOZZLE	1	

No.	PART NAME		PART No.	SPEC&COLOR	Q'ty
F005	SHAFT,NOZZLE		4370ED3006A	TOP NOZZLE	1
F011	SPRING,HINGE		4970ED4004A		2
F013	CONNECTOR ASSEMBLY		4933DD3001A		2
F014	BRACKET,HINGE		4810ED4004A		2
F022	SENSOR ASSEMBLY		6501DD2001A		1
F040	GUIDE ASSEMBLY		4975DD1001A		1
F041	HOSE,INLET		5214DD3001A		1
F042	HOSE,CONNECTOR		5214DD3003A		1
F043	HOSE,CONNECTOR		5214DD3002A		1
F045	COVER,PROTECT		3550DD2001A		1
F050	NUT,COMMON		4020FD3641C		1
F060	GASKET		4986DD3001A		1
F101	PACKING		3920DD3002A		1
F110	RAIL ASSEMBLY		5219DD2002A		1
F117	STOPPER,ROLLER		4620ED3001A		2
F132	PACKING		3920DD3005A	TUB PACKING	1
F141	HINGE ASSEMBLY		4775DD2002A	DOOR RIGHT	1
F142	HINGE ASSEMBLY		4775DD2001A	DOOR LEFT	1
F143	HINGE ASSEMBLY		4775ED3004A	TUB RIGHT	1
F144	HINGE ASSEMBLY		4775ED3003A	TUB LEFT	1
F171	LOCKER,LOCK		4026DD3001A		1
F174	BRACKET,HINGE		4810DD1001A	DOOR FRAME	1
F191	GUIDE,WATER		MEA36937101		1
F192	GUIDE,NOZZLE		4974DD3001A		1
F210	RAIL ASSEMBLY		5219DD2001A		1
K001	DISPENSER		4924FD2123E		1
K002	BRACKET ASSEMBLY		4810FD3805A	FIX DISPENSER TO DOOR LINER	2
K005	HANDLE	WB	3650ED2006A		1
		BB	3650ED2006B		1
		ST	3650ED2006C		1
K006	DECOR,HANDLE	WB	3806ED3008A		2
		BB	3806ED3008B		2
		ST	3806ED3008C		2
K010	COVER,FRONT	WB	3550ED0001E		1
		BB	3550ED0001F		1
		ST	3550ED0001G		1
K030	COVER ASSEMBLY, FRONT	WB	3551DD1003H		1
		BB	3551DD1003F		1
		ST	3551DD1003G		1
K100	DOOR LINER ASSEMBLY		4937DD1001C	DOORLINER+CASING+VENT+DISPENSER	1
K101	PARTS ASSEMBLY		AGM34891601	DOORLINER+DAMPING SHEET+GASKET	1
K110	CASING ASSEMBLY		ABT35083801	BLOWER	1
K121	GASKET		4986DD3003A	BLOWER GASKET	1
K122	COVER,BLOWER		3550ED3011A		1
K124	VENT		MJZ39902101		1
K140	HOSE		5214ER4001S	HOSE, NEW BLOWER	1
K141	CLAMP		4861FR3068M	HOSE ~ BLOWER	1
K200	PANEL ASSEMBLY,CONTROL	WB	AGL32599305		1
		BB	AGL32599306		1

No.	PART NAME		PART No.	SPEC&COLOR	Q'ty
K200	PANEL ASSEMBLY,CONTROL	ST	AGL32599304		1
K201	BUTTON,CONTROL	WB	5020ED3008E	PROGRAM BUTTON	5
		BB	5020ED3008E		5
		ST	5020ED3008E		5
K203	WINDOW	WB	3790ED3007Q		1
		BB	3790ED3007R		1
		ST	3790ED3007P		1
K207	COVER,GUIDE		3550ED3012B	PROGRAM	1
K209	BUTTON,POWER SWITCH	WB	5020ED3011A	POWER BUTTON	1
		BB	5020ED3011B		1
		ST	5020ED3011C		1
K215	COVER,GUIDE		3550ED1009B	OPTION	1
K216	BUTTON,CONTROL	WB	5020ED3012C	PROGRAM OPTION	2
		BB	5020ED3012D		2
		ST	5020ED3012E		2
K220	NAME PLATE,PET	WB	3846ER1001A		1
		BB	3846ER1001B		1
		ST	3846ER1001A		1
K251	PCB ASSEMBLY,MAIN		6871DD1006M		1
K252	PCB ASSEMBLY,DISPLAY		6871DD2001F		1
K253	PCB ASSEMBLY,DISPLAY		6871DD2002D		1
K260	LOCKER ASSEMBLY		4027ED3002A		1
K301	SCREW,CUSTOMIZED		4000FD4268A		4
K302	SCREW,CUSTOMIZED		1SZZED3001A		6
K303	SCREW,CUSTOMIZED		1SZZED3002A		2
K304	SCREW,CUSTOMIZED		1SZZED3003A		10
M001	HOLDER		4930DD3002A		1
M005	GASKET		MDS37912401	SUMP GASKET	1
M006	SUMP ASSEMBLY		AJH31248602		1
M007	SUMP ASSEMBLY		AJH32598001		1
M025	VALVE,CHECK		MJX32862501	VARIO	1
M027	SWITCH,MICRO		3W40025C	VARIO MOTOR	1
M028	CAM,SWITCH		MBJ32856401	CHECK POSITION OF THE VARIO(CAM)	1
M031	PACKING		3920ED4009B		1
M034	BLADE		5832DD4001A	VARIO PACKING	1
M035	PACKING		MFZ32863101		1
M036	HOLDER		4930DD3008A		2
M050	MOTOR ASSEMBLY,AC,PUMP		4681EA2002D	SUMP ASM ~ TUB LOW	1
M060	MOTOR ASSEMBLY,DC,WASHER		4681ED1004A	WATER GUIDE ~ SUMP	1
M081	HEATER ASSEMBLY		5301DD1001A	DRAIN MOTOR	1
M086	SWITCH,MICRO		3W40025P	WASHING MOTOR	2
M087	SENSOR ASSEMBLY		6501ED2002F		1
M088	COVER		3740ED3003A		1
M090	FLOAT ASSEMBLY		4769DD2001A	SOIL SENSOR	1
M110	FILTER ASSEMBLY,MESH		ADQ32598201	HOLDER HEATER	1
M120	CASE ASSEMBLY		ABQ32598101		1
M130	IMPELLER ASSEMBLY		5911ED3003A		1
M210	VALVE ASSEMBLY,INLET		5221DD1001A	PUMP CASE	1
M220	VALVE,CHECK		5220ED4004A		1
M260	BASE,CABINET		MAM34326301		1

No.	PART NAME	PART No.	SPEC&COLOR	Q'ty
M261	COVER ASSEMBLY,BASE	ACQ31707201	DRAIN	1
M262	CASE	3110DD3002A		1
M270	LEG	4778DD3001A		4
M270	LEG	4778DD3001A	JUNCTION BOX	4
M300	ACCESSORY ASSEMBLY	5001DD2001D		0
M301	SCREW,CUSTOMIZED	4W51229F	LEVELING KIT	4
M302	SCREW,CUSTOMIZED	1SZZED3005A	BASE + HINGE SUPPORT	8
M303	SCREW,CUSTOMIZED	1SZZED3006A	SUMP FILTER	1
M304	SCREW,CUSTOMIZED	1SZZFA4305A	IMPELLER	3
M305	SCREW,CUSTOMIZED	4W51194D	SUMP ~ DRAIN PUMP	4
W0RJ	RESISTOR,CHIP	0RJ5600G676	SUMP ~ MOTOR	9

**CAUTION** : BEFORE REPLACING ANY OF THESE COMPONENTS.  
 READ CAREFULLY THE SAFETY PRECAUTIONS IN THIS MANUAL

■ **NOTE** : **S**(SAFETY PARTS), **AL**(ALTERNATIVE PARTS)

LG MODEL: LD-6310TB			Run Date : 2007-12-03	
YOUR MODEL: LDF8812ST / 01			SPECIFICATION: 120V 60Hz	
LOC	DESC	PART No.	COMMENTS	QTY
*001	MANUAL ASSEMBLY,OWNERS	AFN31666707		1
*002	BOX,CARTON	3890DZ3015A		1
*003	MANUAL,SERVICE	3828ED3001X		0
*005	ACCESSORY ASSEMBLY	5001DD4001A		1
A003	DAMPER	4766DD2004A		1
A005	BRACKET, TOP	4810DD4002B		2
A006	SUPPORTER,HOLDER	4980ED2015A		1
A007	SUPPORTER,HOLDER	4980ED2014A		1
A008	SUPPORTER,HOLDER	4980ED2018B		1
A010	CABINET	3090ED1001F		1
A020	CABINET ASSEMBLY	3091DD1001F		1
A040	COVER ASSEMBLY,LOWER	3551DD2001D		1
A050	NOZZLE ASSEMBLY	AGB32598301	LOWER NOZZLE	1
A060	NOZZLE ASSEMBLY	5249DD1001A	UPPER NOZZLE	1
A070	GUIDE ASSEMBLY	4975DD1002A	UPPER NOZZLE	1
A073	WASHER,COMMON	1WZZDD3001A		1
A074	SHAFT,NOZZLE	4370ED3007A		1
A080	RACK	3750DD2001A	CUP SHELF	2
A101	DECOR,HANDLE	3806DD3004A	STS	2
A102	HANDLE	3650DD3001A	FRONT	2
A103	HANDLE	3650DD3002A	REAR	2
A110	BASKET ASSEMBLY,SPOON	5005DD1001A		1
A120	HARNES, MULTI	EAD35070401		1
A130	HOSE ASSEMBLY,DRAIN	AEM30700301	INNER PHI 15, 21	1
A140	RACK ASSEMBLY	3751DD1001A	LOWER RACK	1
A141	RACK	3750ED1004A		1
A142	ROLLER ASSEMBLY	4581DD3003B		8
A144	RACK	3750DD2003A		2
A147	HOLDER	4930DD3006A		3
A148	RACK	3750DD1001A		1
A149	RACK	3750DD1002A		1
A150	RACK ASSEMBLY	3751DD1002C	UPPER RACK	1
A151	RACK	3750ED1005A		1
A155	GUIDE ASSEMBLY	AEC32598701	RIGHT	1
A156	GUIDE ASSEMBLY	AEC32598601	LEFT	1
A157	HOLDER	4930DD3003A		2
A158	HOLDER	4930DD3005A		3
A159	RACK	3750DD2002A		2
A160	FILTER ASSEMBLY	6201EC1006A		1
A301	SCREW, TAPTITE	1SBF0402418		3
E010	BUSH	4830ED4001A		2
F001	FRAME ASSEMBLY	3211DD1001A		1
F004	NOZZLE ASSEMBLY	5249DD2001A	TOP NOZZLE	1
F005	SHAFT,NOZZLE	4370ED3006A	TOP NOZZLE	1
F011	SPRING, HINGE	4970ED4004A		2

No.	PART NAME	PART No.	SPEC&COLOR	Q'ty
F013	CONNECTOR ASSEMBLY	4933DD3001A		2
F014	BRACKET,HINGE	4810ED4004A		2
F022	SENSOR ASSEMBLY	6501DD2001A		1
F040	GUIDE ASSEMBLY	4975DD1001A		1
F041	HOSE,INLET	5214DD3001A		1
F042	HOSE,CONNECTOR	5214DD3003A		1
F043	HOSE,CONNECTOR	5214DD3002A		1
F045	COVER,PROTECT	3550DD2001A		1
F050	NUT,COMMON	4020FD3641C		1
F060	GASKET	4986DD3001A		1
F101	PACKING	3920DD3002A		1
F121	STOPPER,ROLLER	MJB32864101		4
F122	RAIL	MGT32863801		2
F123	HOUSING ASSEMBLY,BEARING	AEN32597901		2
F132	PACKING	3920DD3005A	TUB PACKING	1
F141	HINGE ASSEMBLY	4775DD2002A	DOOR RIGHT	1
F142	HINGE ASSEMBLY	4775DD2001A	DOOR LEFT	1
F143	HINGE ASSEMBLY	4775ED3004A	TUB RIGHT	1
F144	HINGE ASSEMBLY	4775ED3003A	TUB LEFT	1
F171	LOCKER,LOCK	4026DD3001A		1
F174	BRACKET,HINGE	4810DD1001A	DOOR FRAME	1
F191	GUIDE,WATER	MEA36937101		1
F192	GUIDE,NOZZLE	4974DD3001A		1
F240	LAMP,INCANDESCENT	6913ER4001B		2
K001	DISPENSER	4924FD2123E		1
K002	BRACKET ASSEMBLY	4810FD3805A	FIX DISPENSER TO DOOR LINER	2
K005	HANDLE	3650ED2006E		1
K006	DECOR,HANDLE	3806ED3008C		2
K010	COVER,FRONT	3550ED0001H		1
K030	COVER ASSEMBLY,FRONT	3551DD1003J		1
K100	DOOR LINER ASSEMBLY	4937DD1001C	DOORLINER+CASING+VENT+DISPENSER	1
K101	PARTS ASSEMBLY	AGM34891601	DOORLINER+DAMPING SHEET+GASKET	1
K110	CASING ASSEMBLY	ABT35083801	BLOWER	1
K121	GASKET	4986DD3003A	BLOWER GASKET	1
K122	COVER,BLOWER	3550ED3011A		1
K124	VENT	MJZ39902101		1
K140	HOSE	5214ER4001S	HOSE, NEW BLOWER	1
K141	CLAMP	4861FR3068M	HOSE ~ BLOWER	1
K200	PANEL ASSEMBLY,CONTROL	AGL32598401		1
K207	COVER,GUIDE	MCK34185201		1
K216	BUTTON,CONTROL	MBG32865301		1
K220	NAME PLATE,PET	3846ER1001B		1
K230	WINDOW ASSEMBLY	AJX32598501		1
K251	PCB ASSEMBLY,MAIN	EBR33469401		1
K252	PCB ASSEMBLY,DISPLAY	EBR33469501		1
K254	PCB ASSEMBLY,DISPLAY	EBR33469701	FRONT PROCESS INDICATOR	1
K260	LOCKER ASSEMBLY	4027ED3002D		1
K301	SCREW,CUSTOMIZED	4000FD4268A	DOOR LINER ~ HINGE	4
K302	SCREW,CUSTOMIZED	1SZZED3001A	DOOR LINER~PANEL~FRONT COVER	6

No.	PART NAME	PART No.	SPEC&COLOR	Q'ty
K303	SCREW,CUSTOMIZED	1SZZED3002A	LATCH~PANEL	2
K304	SCREW,CUSTOMIZED	1SZZED3003A	DOOR LINER~FRONT COVER	6
M001	HOLDER	4930DD3002A		1
M005	GASKET	MDS37912401	SUMP GASKET	1
M006	SUMP ASSEMBLY	AJH31248601		1
M007	SUMP	AJH32598001		1
M025	VALVE,CHECK	MJX32862501	VARIO	1
M026	MOTOR ASSEMBLY,AC,DRAIN	4681ED3001B	VARIO MOTOR	1
M027	SWITCH,MICRO	3W40025C	CHECK THE POSITION OF THE VARIO(CAM)	1
M028	CAM,SWITCH	MBJ32856401		1
M031	PACKING	3920ED4009B	VARIO PACKING	1
M034	BLADE	5832DD4001A		1
M035	PACKING	MFZ32863101		1
M036	HOLDER	4930DD3008A	SUMP ASM ~ TUB LOW	2
M038	HOLDER	4930DD3012A	WATER GUIDE ~ SUMP	1
M050	MOTOR ASSEMBLY,AC,PUMP	4681EA2002D	DRAIN MOTOR	1
M060	MOTOR ASSEMBLY,DC	4681ED1004A	WASHING MOTOR	1
M081	HEATER ASSEMBLY	5301DD1001A		1
M086	SWITCH,MICRO	3W40025P		2
M087	SENSOR ASSEMBLY	6501ED2002F	SOIL SENSOR	1
M088	COVER	3740ED3003A	HOLDER HEATER	1
M090	FLOAT ASSEMBLY	4769DD2001A		1
M110	FILTER ASSEMBLY,MESH	ADQ32598201		1
M120	CASE ASSEMBLY	ABQ32598101	PUMP CASE	1
M130	IMPELLER ASSEMBLY	5911ED3003A		1
M210	VALVE ASSEMBLY,INLET	5221DD1001A		1
M220	VALVE,CHECK	5220ED4004A	DRAIN	1
M221	COVER	MCK32863301		1
M260	BASE,CABINET	MAM34326301		1
M261	COVER ASSEMBLY,BASE	ACQ31707201		1
M262	CASE	3110DD3002A	JUNCTION BOX	1
M270	LEG	4778DD3001A		4
M300	ACCESSORY ASSEMBLY	5001DD2001C	LEVELING KIT	1
M301	SCREW,CUSTOMIZED	4W51229F	BASE + HINGE SUPPORT	4
M302	SCREW,CUSTOMIZED	1SZZED3005A	SUMP FILTER	8
M303	SCREW,CUSTOMIZED	1SZZED3006A	IMPELLER	1
M304	SCREW,CUSTOMIZED	1SZZFA4305A	SUMP ~ DRAIN PUMP	3
M305	SCREW,CUSTOMIZED	4W51194D	SUMP ~ MOTOR	4



# Appendix. A

CHANGED PART FROM DEC. 2007



	BEFORE (LDF9810ST, S/N : ~1DD10001)	AFTER (LDF9810ST / 01, S/N : 1DD10001~)
<p><b>K001</b> DOORLINER ASSEMBLY</p> <p>*Casing ASM &amp; Vent were chang ed to Improve Dr ying performance</p> <p>*Hose added</p>	<p>4937DD1001B</p>	<p>4937DD1001C</p>
<p><b>K110</b> CASING ASS SEMBLY</p> <p>*Casing ASM w as changed to Im prove Drying per formance</p>	<p>5835ED2002D</p>	<p>ABT35083801</p>
<p><b>K124</b> VENT</p> <p>*Vent was chang ed to Improve Dr ying performance</p>	<p>MJZ36939301</p>	<p>MJZ39902101</p>



# Appendix. B

## B-1. Modified parts to improve drying performance.

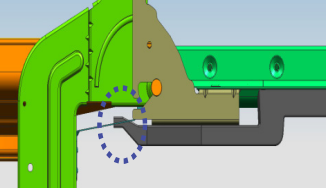
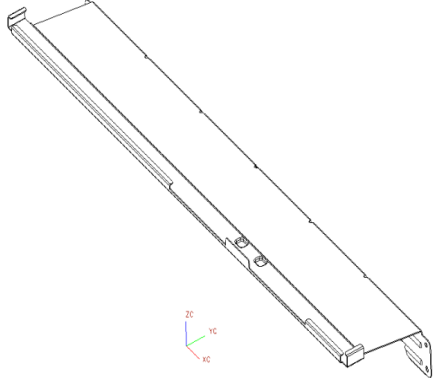
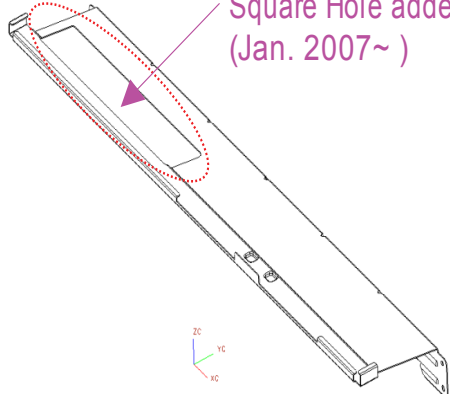
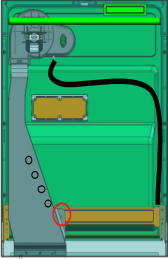
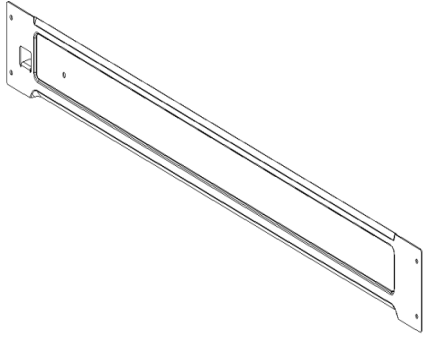
- Check original parts & replace (or modify) with new parts to improve drying performance.

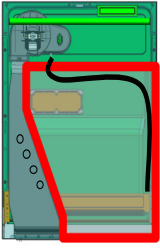
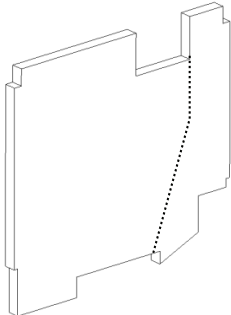
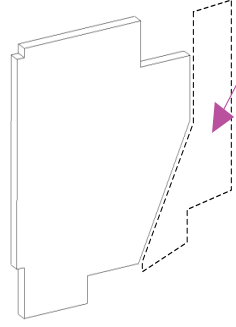
	BEFORE	AFTER
<p><b>F001</b> FRAME ASSEMBLY, LOWER</p> <p>*Frame was modified to avoid interference with new vent</p> 	<p>AGL33667101</p> 	<p>AGL33667101</p> <p>Square Hole added (Jan. 2007~)</p> 
<p><b>F174</b> HINGE BRACKET</p> <p>*Hinge bracket was modified to include a new vent mounting hole</p> 	<p>4810DD1001A</p> 	<p>4810DD1001A</p> <p>Hole added (Aug. 2007~)</p>  <p>* Drill a hole to fix new vent</p>
<p><b>FELT</b> (In Frontcover)</p> <p>*Felt was modified to avoid interference with new vent</p> 	<p>4766DD1001B</p> 	<p>4766DD1001A</p> <p>Trim (Dec. 2007~)</p>  <p>* Cut the interference portion</p>



# Appendix. B

## B-2. Modified parts to improve drying performance.

- Check original parts & replace (or modify) with new parts to improve drying performance.

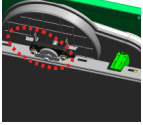
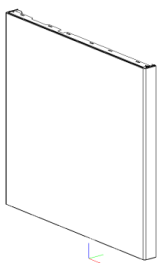
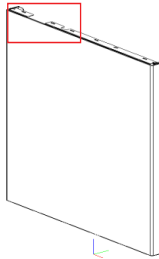
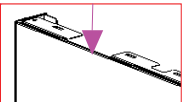
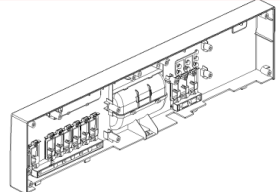
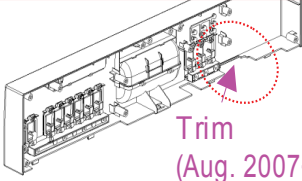
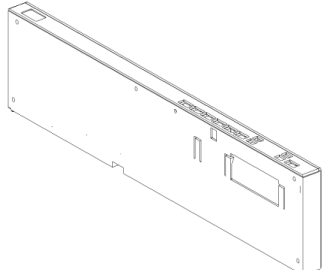
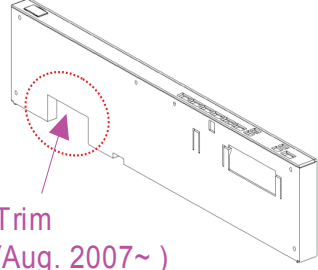
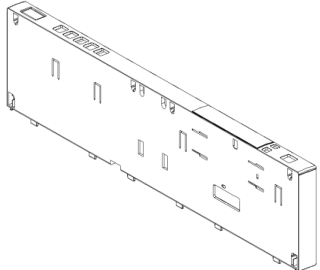
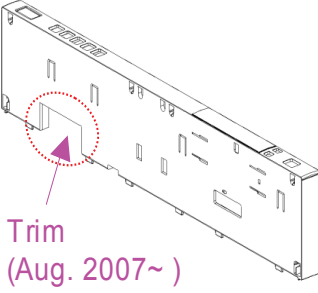
	Part Numbers		BEFORE	AFTER
<b>K010</b> (LDS5811 Series Only) Front Cover *Front Cover was modified to avoid interference with new blower assembly 	W W	3550DD1004A	NOTE: It is not recommended to modify this part—replace part if installing new drying system on semi model. 	 Trim (Dec. 2007~) 
	B B	3550DD1004B		
	S T	3550DD1004C		
<b>K200</b> (LDS5811 Series ONLY) CONTROL PANEL ASSEMBLY *Control panel was modified to avoid interference with new blower assembly	W W	AGL32586501	NOTE: It is not recommended to modify this part—replace part if installing new drying system on semi model. 	 Trim (Aug. 2007~)
	B B	AGL32586502		
	S T	AGL32586503		
<b>K200</b> (LDF8812ST ONLY) CONTROL PANEL ASSEMBLY *Control panel was modified to avoid interference with new blower assembly	AGL32598401			 Trim (Aug. 2007~)
<b>K200</b> (LDF6810 Series ONLY) CONTROL PANEL ASSEMBLY *Control panel was modified to avoid interference with new blower assembly	W W	AGL32599305		 Trim (Aug. 2007~)
	B B	AGL32599306		
	S T	AGL32599304		



## Appendix. C

□ If it is necessary to retrofit an earlier model with the new drying system, please follow the instructions below for modifying or replacing parts.

- 1) Remove front door panel & control panel.
- 2) Remove old blower & vent.
- 3) Cut the door liner white felt pad as shown\*. Scissors work best for cutting the felt. (See Appendix C for part number if felt is to be replaced.)

\*NOTE: The white felt can be marked with a felt pen using the new vent as a template.

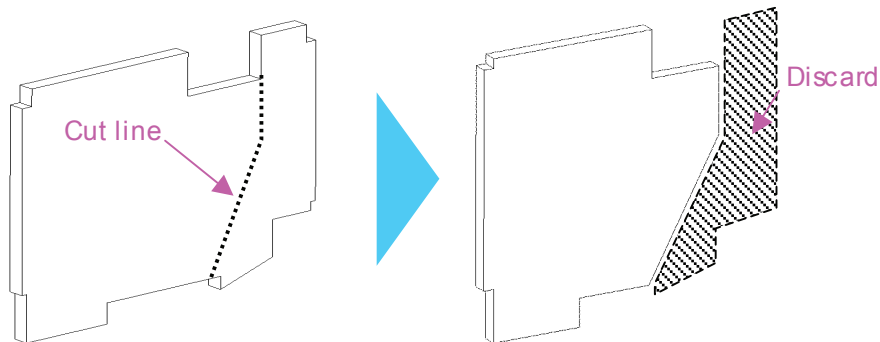

\* Use scissors to remove the highlighted portion of the felt pad where it interferes with the vent as shown.

- 4) Assemble and mount the new blower & vent.
- 5) The control panel frame must be modified or replaced. If it is to be modified for blower clearance, cut out areas shown in the photos below\*. Test fit panel to door liner prior to assembly to make sure panel does not touch blower motor or housing as this could cause excess noise.

\*NOTE: It is not recommended to modify the semi-control panel or front door panel. Retrofit of the new drying system to LDS5811xx models should only be done by replacing the front door panel and control panel. ( see Appendix C for parts)

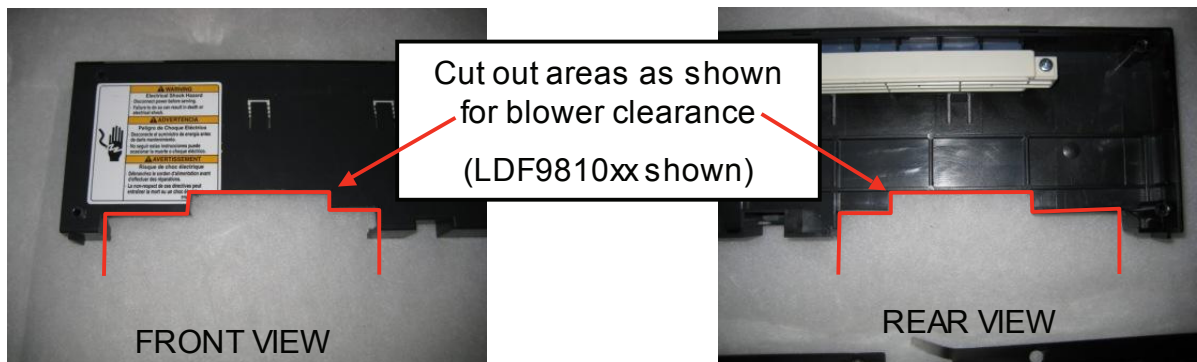



# Appendix. C

## i □ Retrofit instructions continued

6) Using the new vent as a template, drill a new hole\* for mounting the vent. Attach the vent using the black screw from the old vent. Align the bottom of the vent with the bottom of the door panel when assembling vent.

\* NOTE: Be careful not to damage the door liner when drilling the hole.



Mark the location to drill the hole. Make sure the bottom of the vent will align with the bottom of the front door panel.



Drill the pilot hole. Be careful not to damage the door liner when drilling the hole.

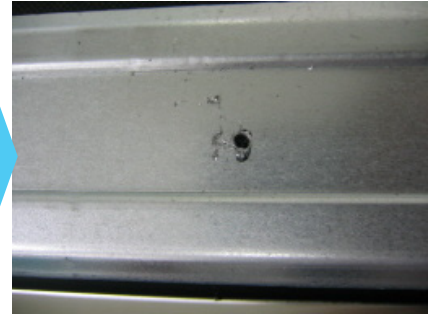

7) Attach one end of the rubber drain hose to the fitting on the bottom of the blower housing and secure with the clamp. Route the drain hose down the right side of the door behind the screw and foam so it can drain into the tub.

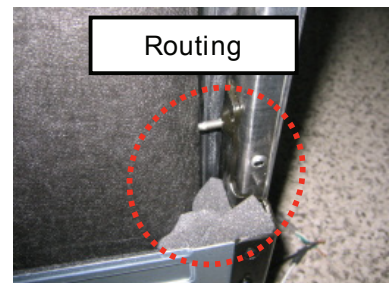
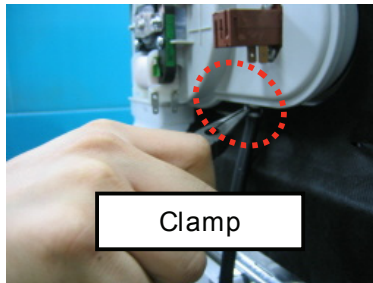
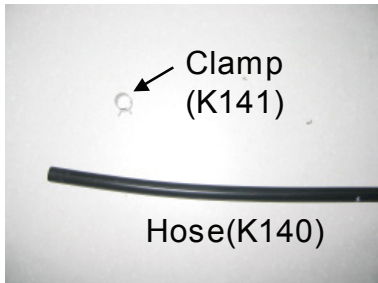

8) Secure the drain hose in position with the retaining wire at the dispenser or a piece of tape as needed.

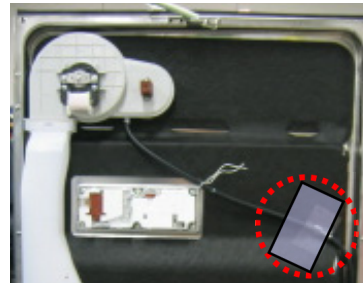
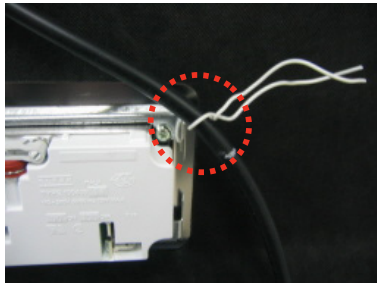

9) Reassemble control panel and front door panel. Test for proper operation.



# MEMO

---



# MEMO

---