



LG

REFRIGERATOR

SERVICE MANUAL

CAUTION
BEFORE SERVICING THE UNIT,
READ THE SAFETY PRECAUTIONS IN THIS MANUAL.

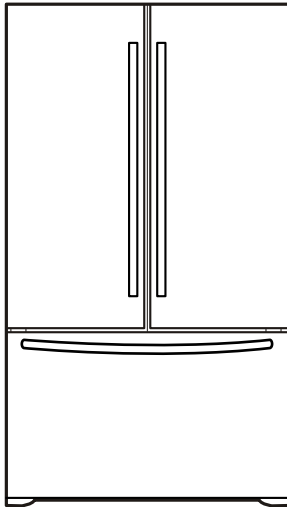

MODELS:
LFC20740**

CONTENTS

SAFETY PRECAUTIONS	2
1. SPECIFICATIONS	3
2. PARTS IDENTIFICATION	4
3. DISASSEMBLY	5
3.1 DOOR	5
3.2 DOOR ALIGNMENT	6
3.3 FAN AND FAN MOTOR	7
3.4 DEFROST CONTROL ASSEMBLY	7
3.5 LAMP	7
3.6 REFRIGERATOR CONTROL BOX	7
3.7 MULTI DUCT	7
4. ADJUSTMENT	8
4.1 COMPRESSOR	8
4.2 PTC-STARTER	8
4.3 OLP (OVERLOAD PROTECTOR)	9
4.4 TO REMOVE THE COVER PTC	9
5. CIRCUIT DIAGRAM	10
6. TROUBLESHOOTING	11
6.1 COMPRESSOR AND ELECTRICAL COMPONENTS	11
6.2 PTC AND OLP	12
6.3 OTHER ELECTRICAL COMPONENTS	13
6.4 SERVICE DIAGNOSIS CHART	14
6.5 REFRIGERATION CYCLE	15
7. OPERATION PRINCIPLE AND REPAIR METHOD OF ICEMAKER	17
8. DESCRIPTION OF FUNCTION & CIRCUIT OF MICOM	20
9. EXPLODED VIEW & REPLACEMENT PARTS LIST	40

SAFETY PRECAUTIONS

Please read the following instructions before servicing your refrigerator.

1. Check the refrigerator for current leakage.
2. To prevent electric shock, unplug before servicing.
3. Always check line voltage and amperage.
4. Use standard electrical components.
5. Don't touch metal products in the freezer with wet Hands. This may cause frost bite.
6. Prevent water from spilling on to electric elements or the Machine parts.

7. Before tilting the refrigerator, remove all materials from On or in the refrigerator.
8. When servicing the evaporator, wear gloves to prevent Injuries from the sharp evaporator fins.
9. Service on the refrigerator should be performed by a Qualified technician. Sealed system repair must be Performed by a CFC certified technician.

1. SPECIFICATIONS

MODELS		LFC20740**
SPECIFICATIONS		
GENERAL FEATURES	CAPACITY litros(F/R/T)	180.97/374.23/555.20
	DIMENSIONS in(W*H*D)	29 7/8*68 3/7*34 5/9
	WEIGHT kg	111
	HANDLE TYPE	CURVED
	REVERSIBLE DOOR	NO
	DOOR FINISH	STAINLESS STEEL/PCM/VCM
	REFRIGERANT/gr	R134a 120±3gr
FREEZER	ICE TRAY	NO
	SHELF	NO
	BASKET DOOR	NO
	LAMP	YES(1)
REFRIGERATOR	TRAY MEAT(SNACK PAN)	YES(1)
	SHELF	4fix
	MAGIC CRISPER	NO
	LAMP	YES(2)
	TRAY EGG	YES(1)
	GUIDE BOTTLE	YES(2)
	TRAY VEGETABLE	NORMAL
	BASKET DOOR	3 LEFT+3RIGHT

2. PARTS IDENTIFICATION

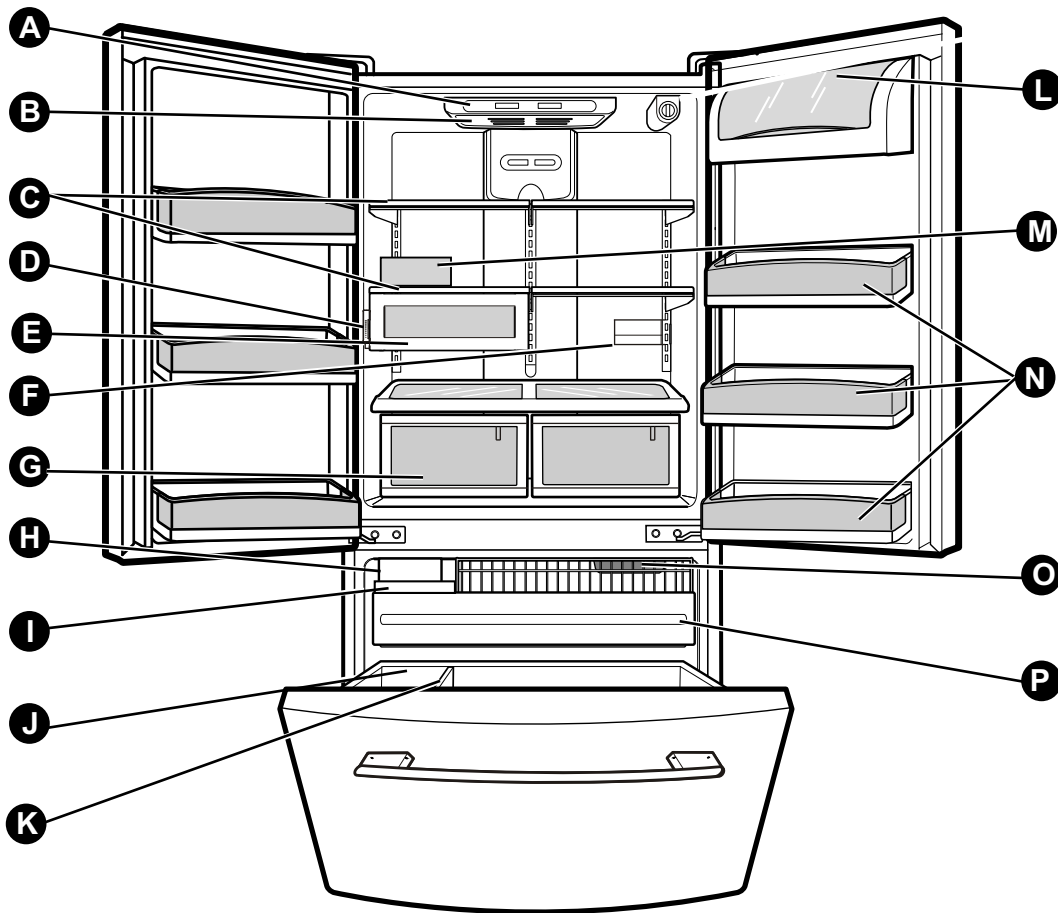

Use this section to become more familiar with the parts and features.

NOTE: This guide covers several different models. The refrigerator you have purchased may have some or all of the items listed below. The locations of the features shown below may not match your model.

A Digital Sensor Control*

B Refrigerator Light

C Shelves

D Temperature Control*

E Snack Pan

F Can Dispenser*

G Optibin Crisper
Keeps fruits and vegetable fresh and crisper

H Customcube Icemaker*

I Ice Tray *

J Durabase

K Divider

L Dairy Bin

M Egg Box

N Refrigerator Door Rack

O Freezer Light

P Pull out Drawer

*on some models

3. DISASSEMBLY

3-1 DOOR

► Left Door

- Loosen the cover screw (1).
- Disconnect door switch wire (2).
- Loosen hinge bolts (3).
- Lift off the top hinge (4).
- Place the door on a non-scratching surface with the inside up.

► Right Door

- Loosen the cover screw (1).
- Disconnect door switch wire (2).
- Disconnect wire harness (5).
- Loosen hinge bolts (3).
- Loosen ground screw (6).
- Lift off the top hinge (4).
- Place the door on a non-scratching surface with the inside up.

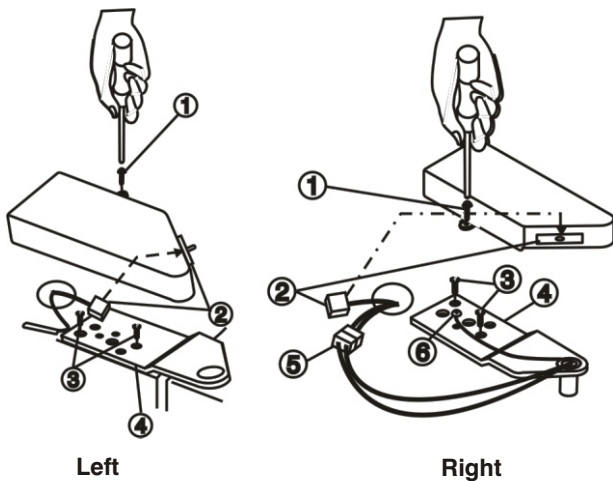

Figure 1

Door Gasket Removal

1. Remove door frame cover

Starting at top of cover and working down, snap cover out and away from door.

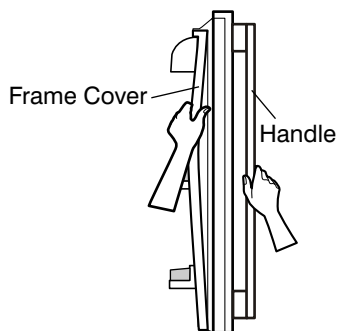

Figure 2

2. Remove gasket bracket clips

There are two clips on each door. Start bracket removal near one of the middle clips.

- 1) Pull gasket back to expose gasket bracket clip and door frame.
- 2) Insert a flat tip screwdriver into seam between gasket bracket and door frame and pry back until clips snap out.
- 3) Continue prying back along seam until all clips snap out.

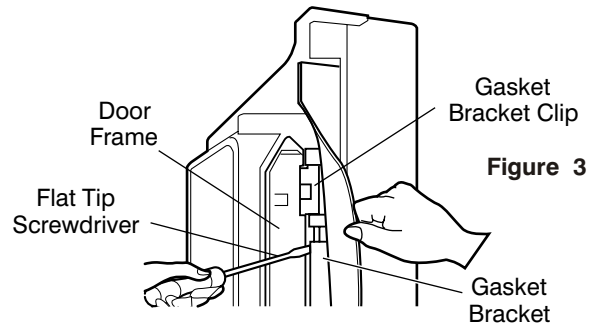

Figure 3

3. Remove gasket

Pull gasket free from gasket channel on the three remaining sides of door.



Figure 4

Door Gasket Replacement

1. Insert gasket bracket clips

- 1) Insert gasket bracket edge beneath door frame edge.
- 2) Turn upper gasket bracket spring so that both spring ends are in the door channel.
- 3) Push in clip until you hear it snap securely into place.

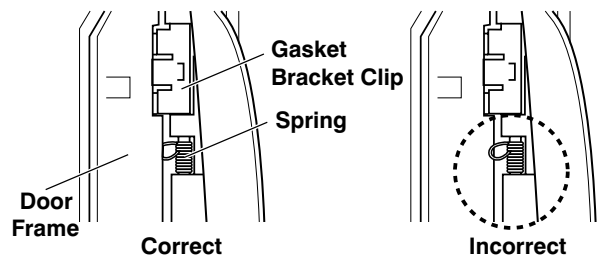

Figure 5

- 4) Push in remaining two clips until you hear each snap securely into place.

Note: Make sure that no part of gasket bracket edge protrudes from beneath door frame edge.

2. Insert gasket into channel

1) Snap gasket assembly into the door bracket.

<Inserting the Gasket Assembly into the Bracket Door>

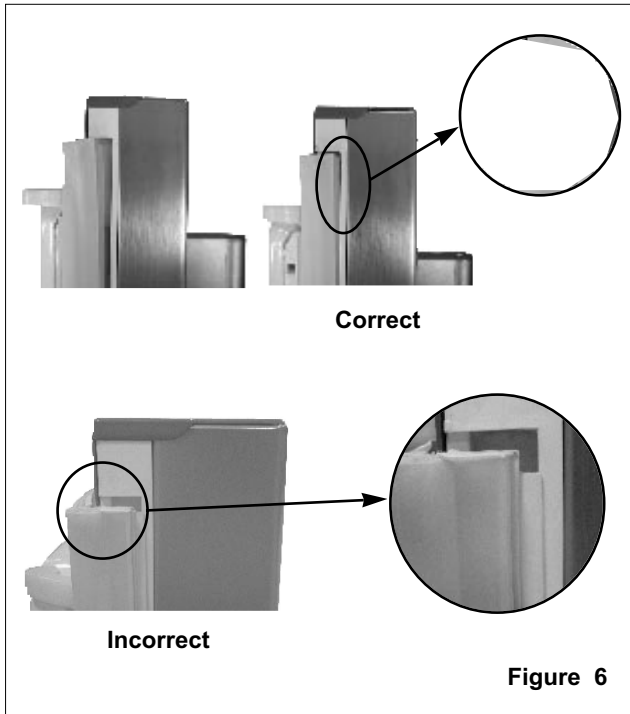

Figure 6

2) Press gasket into channels on the three remaining sides of door.

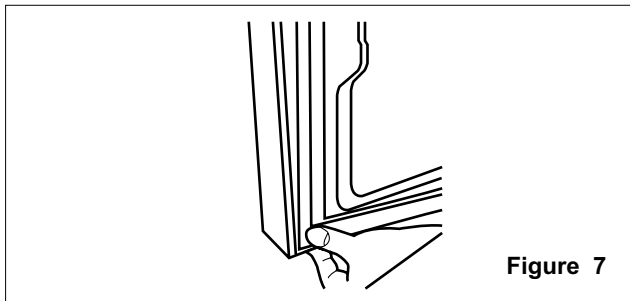

Figure 7

3. Replace door frame cover

Starting at top of cover and working down, snap cover back into door.

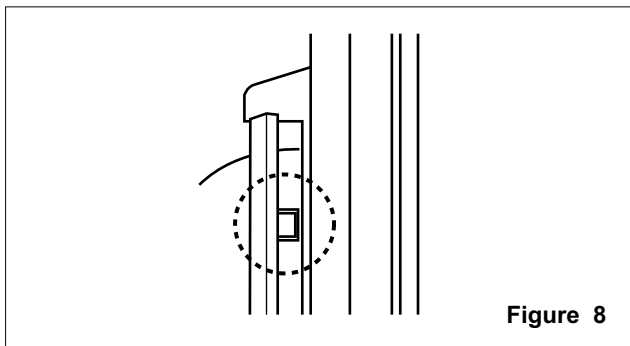

Figure 8

3-2 DOOR ALIGNMENT

If the space between your doors is uneven, follow the instructions below to align the doors:

1. With one hand, lift up the door you want to raise at middle hinge.
2. With other hand, use pliers to insert snap ring as shown.
3. Insert additional snap rings until the doors are aligned. (Three snap rings are provided with unit.)

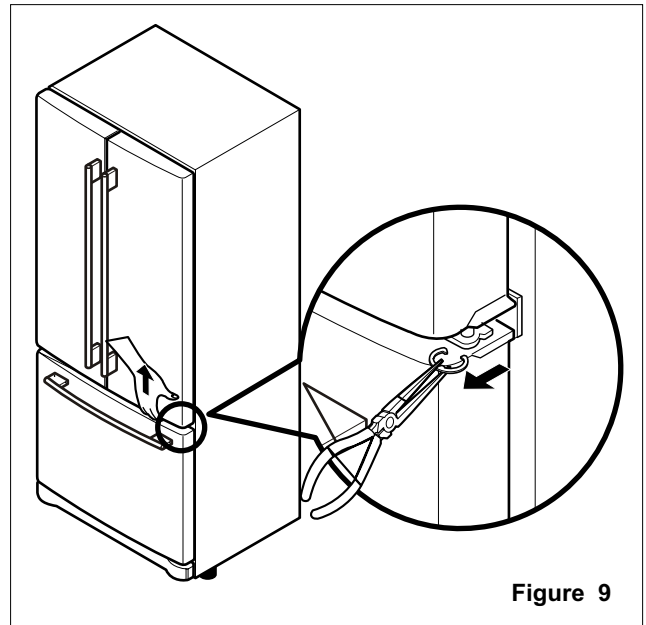

Figure 9

3-3 FAN AND FAN MOTOR

1. Remove the freezer shelf. (If your refrigerator has an icemaker, remove the icemaker first)
2. Remove the plastic guide for slides on left side by unscrewing phillips head screws.
3. Remove the grille by removing one screw and pulling the grille forward.
4. Remove the Fan Motor assembly by loosening 2 screws and disassembling the shroud.
5. Pull out the fan and separate the Fan Motor and Bracket.

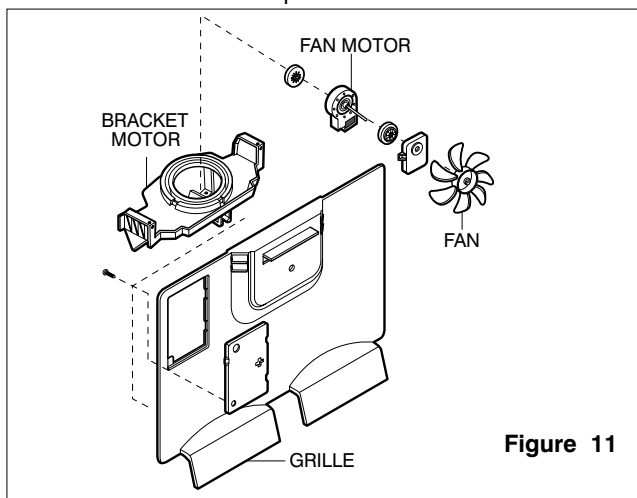

Figure 11

3-4 DEFROST CONTROL ASSEMBLY

Defrost Control assembly consists of Defrost Sensor and FUSE-M.

The Defrost Sensor works to defrost automatically. It is attached to the metal side of the Evaporator and senses its temperature. At 72°C, it turns the Defrost Heater off.

Fuse-M is a safety device for preventing over-heating of the Heater when defrosting.

1. Pull out the grille assembly. (Figure 12)
2. Separate the connector with the Defrost Control assembly and replace the Defrost Control assembly after cutting the Tie Wrap. (Figure 13)

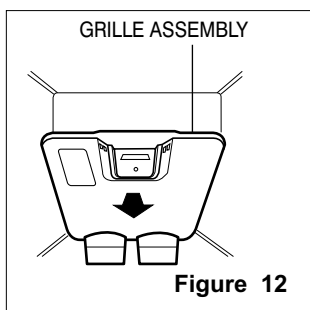

Figure 12

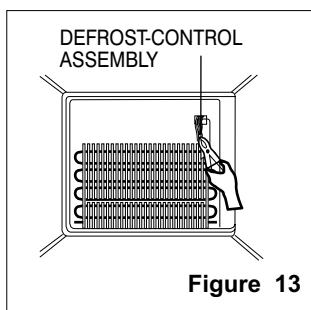

Figure 13

3-5 LAMP

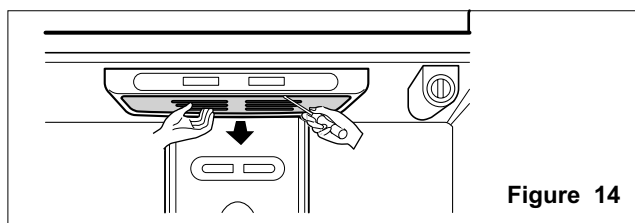

Figure 14

3-5-1 To change the refrigerator light (figure 14)

1. Unplug the power cord from the outlet.
2. Remove refrigerator shelves.
3. Release the hooks on the front of the light shield with the help of a flat screwdriver and pull the shield down to remove it.
4. Turn the bulb counterclockwise.
5. To assemble, first insert the hooks at the back and then push up the light shield upwards. (Max. 60 W2EA).

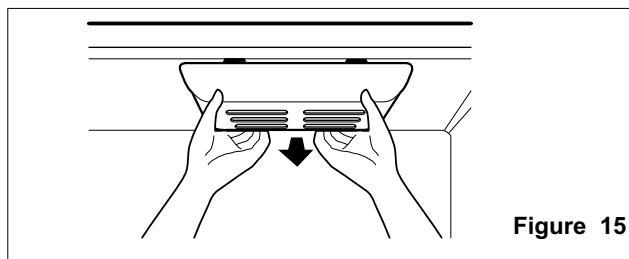

Figure 15

3-5-2 Freezer Compartment Lamp (figure 15)

1. Unplug refrigerator or disconnect power.
2. Reach behind light shield to remove bulb.
3. Replace bulb with a 60-watt appliance bulb.
4. Plug in refrigerator or reconnect power.

3-6 CONTROL BOX-REFRIGERATOR

1. First, remove all shelves in the refrigerator, then remove the Refrigerator control Box by loosening 2 screws.

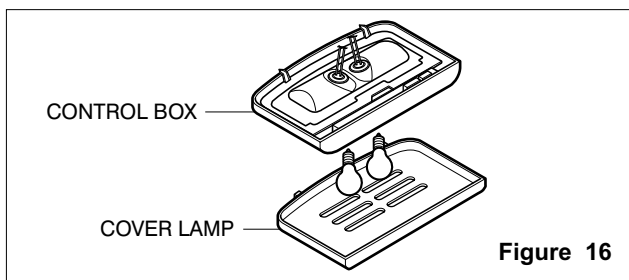

Figure 16

2. Remove the Refrigerator Control Box by pulling it downward.
3. Disconnect the lead wire on the right position and separate the lamp sockets.

3-7 MULTI DUCT

1. Remove the upper and lower Caps by using a flat screwdriver, and remove 2 screws. (Figure 17)
2. Disconnect the lead wire on the bottom position.

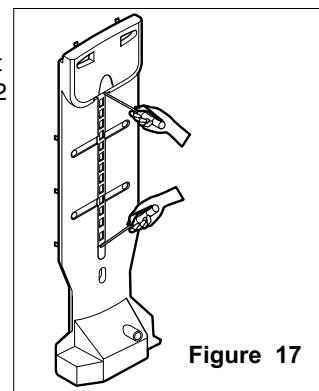

Figure 17

4. ADJUSTMENT

4-1 COMPRESSOR

4-1-1 Role

The compressor intakes low temperature and low pressure gas from the evaporator of the refrigerator and compresses this gas to high-temperature and high-pressure gas. It then delivers the gas to the condenser.

4-1-2 Composition

The compressor includes overload protection. The PTC starter and OLP (overload protector) are attached to the outside of the compressor. Since the compressor is manufactured to tolerances of 1 micron and is hermetically sealed in a dust and moisture-free environment, use extreme caution when repairing it.

4-1-3 Note for Usage

- (1) Be careful not to allow over-voltage and over-current.
- (2) If compressor is dropped or handled carelessly, poor operation and noise may result.
- (3) Use proper electric components appropriate to the Particular Compressor in your product.
- (4) Keep Compressor dry.
If the Compressor gets wet (in the rain or a damp environment) and rust forms in the pin of the Hermetic Terminal, poor operation and contact may result.
- (5) When replacing the Compressor, be careful that dust, humidity, and soldering flux don't contaminate the inside of the compressor. Contamination in the cylinder may cause noise, improper operation or even cause it to lock up.

4-2 PTC-STARTER

4-2-1 Composition of PTC-Starter

- (1) PTC (Positive Temperature Coefficient) is a no-contact semiconductor starting device which uses ceramic material consisting of BaTiO₃.
- (2) The higher the temperature is, the higher the resistance value. These features are used as a starting device for the Motor.

4-2-2 Role of PTC-Starter

- (1) The PTC is attached to the Sealed Compressor and is used for starting the Motor.
- (2) The compressor is a single-phase induction motor. During the starting operation, the PTC allows current flow to both the start winding and main winding.

4-2-3 PTC-Applied Circuit Diagram

•Starting Method for the Motor

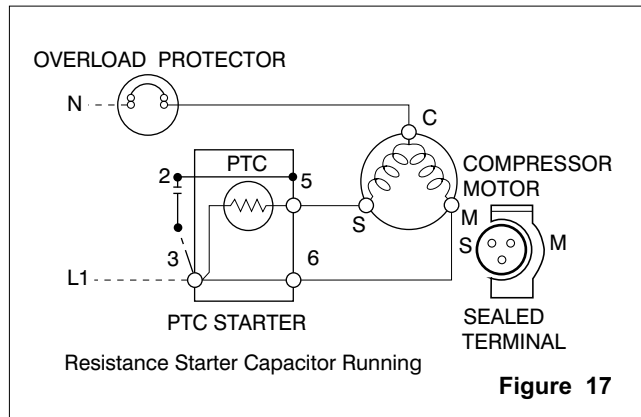

4-2-4 Motor Restarting and PTC Cooling

- (1) It requires approximately 5 minutes for the pressure to equalize before the compressor can restart.
- (2) The PTC device generates heat during operation. Therefore, it must be allowed to cool before the compressor can restart.

4-2-5 Relation of PTC-Starter and OLP

- (1) If the compressor attempts to restart before the PTC device is cooled, the PTC device will allow current to flow only to the main winding.
- (2) The OLP will open because of the over current condition. This same process will continue (3 to 5 times) when the compressor attempts to restart until the PTC device has cooled. The correct OLP must be properly attached to prevent damage to the compressor.

Parts may appear physically identical but could have different electrical ratings. Replace parts by part number and model number. Using an incorrect part could result in damage to the product, fire, injury, or possibly death.

4-2-6 Note for Using the PTC-Starter

- (1) Be careful not to allow over-voltage and over-current.
- (2) Do not drop or handle carelessly.
- (3) Keep away from any liquid.
If liquid such as oil or water enters the PTC, PTC materials may fail due to breakdown of their insulating capabilities.
- (4) If the exterior of the PTC is damaged, the resistance value may be altered. This can cause damage to the compressor and result in a no-start or hard-to-start condition.
- (5) Always use the PTC designed for the compressor and make sure it is properly attached to the compressor. Parts may appear physically identical but could have different electrical ratings. Replace parts by part number and model number. Using an incorrect part could result in damage to the product, fire, injury, or possibly death.

4-3 OLP (OVERLOAD PROTECTOR)

4-3-1 Definition of OLP

- (1) OLP (OVERLOAD PROTECTOR) is attached to the Compressor and protects the Motor by opening the circuit to the Motor if the temperature rises and activating the bimetal spring in the OLP.
- (2) When high current flows to the Compressor motor, the Bimetal works by heating the heater inside the OLP, and the OLP protects the Motor by cutting off the current flowing to the Compressor Motor.

4-3-2 Role of the OLP

- (1) The OLP is attached to the Sealed Compressor used for the Refrigerator. It prevents the Motor Coil from being started in the Compressor.
- (2) For normal operation of the OLP, do not turn the Adjust Screw of the OLP in any way.

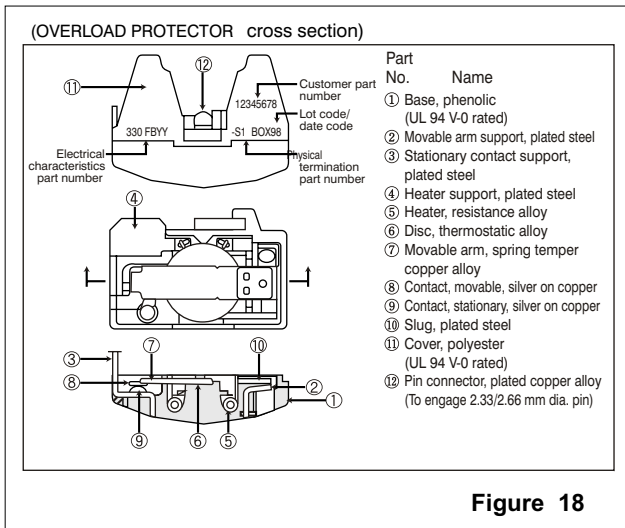
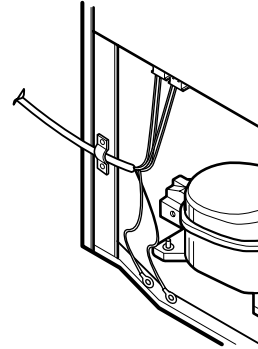
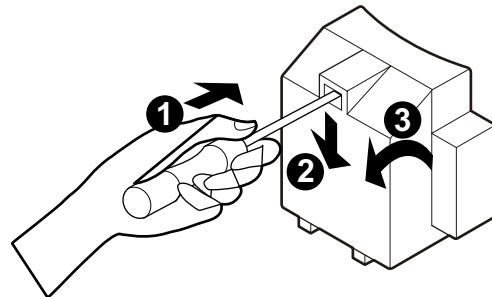

Figure 18

4-4 TO REMOVE THE COVER PTC



- 1) Remove the Cover Back M/C.
- (2) Disconnect two housing upper side of comp connected in.
- (3) Loosen two screws on comp base.



- (4) Use a L-shaped flap tool to pry off the cover.
- (5) Assembly in reverse order of disassembly.

5. CIRCUIT DIAGRAM



LG Electronics CIRCUIT DIAGRAM

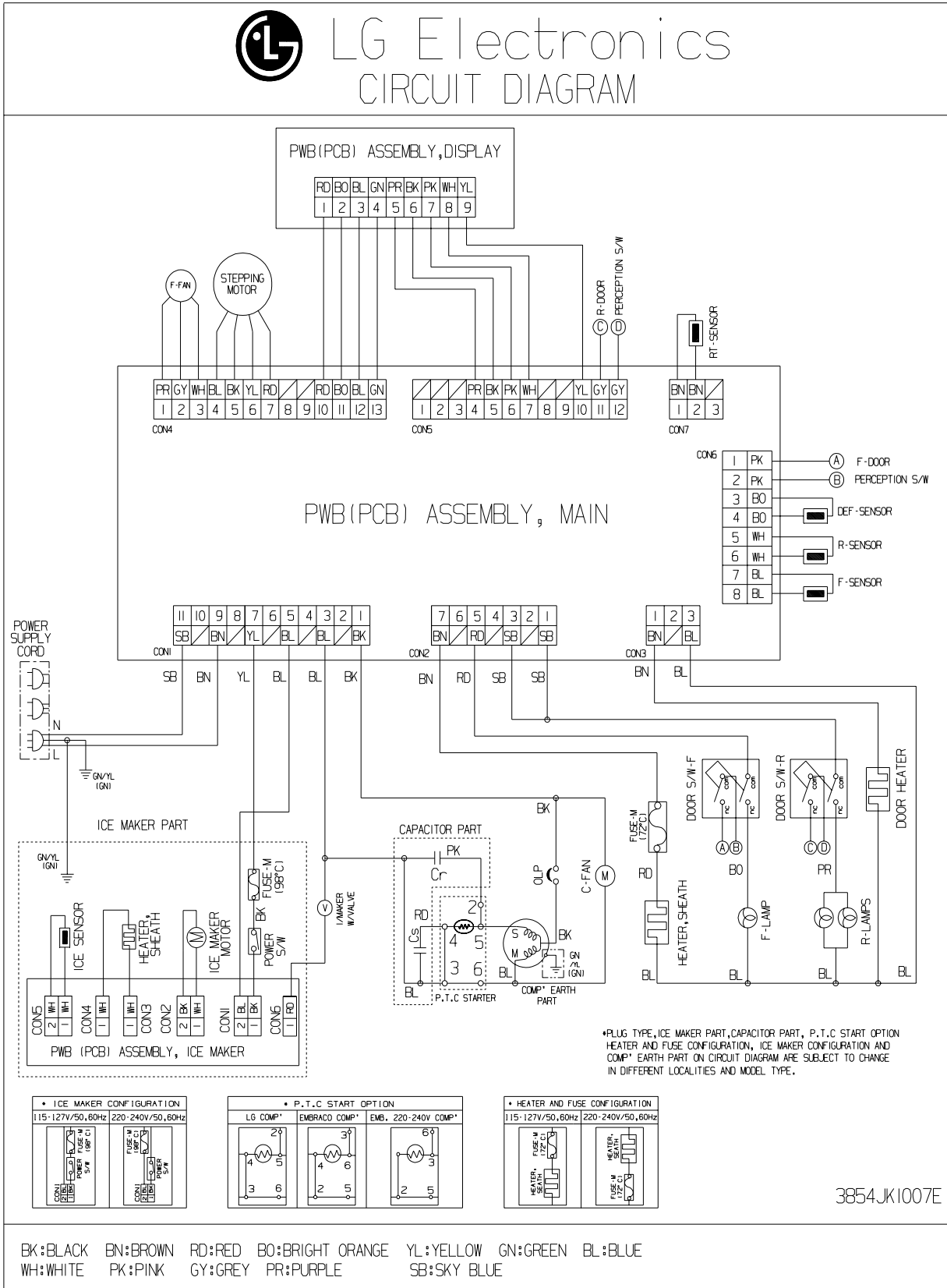

3854JK1007E

BK:BLACK BN:BROWN RD:RED BO:BRIGHT ORANGE YL:YELLOW GN:GREEN BL:BLUE
WH:WHITE PK:PINK GY:GREY PR:PURPLE SB:SKY BLUE

6. TROUBLESHOOTING

6-1 COMPRESSOR AND ELECTRIC COMPONENTS

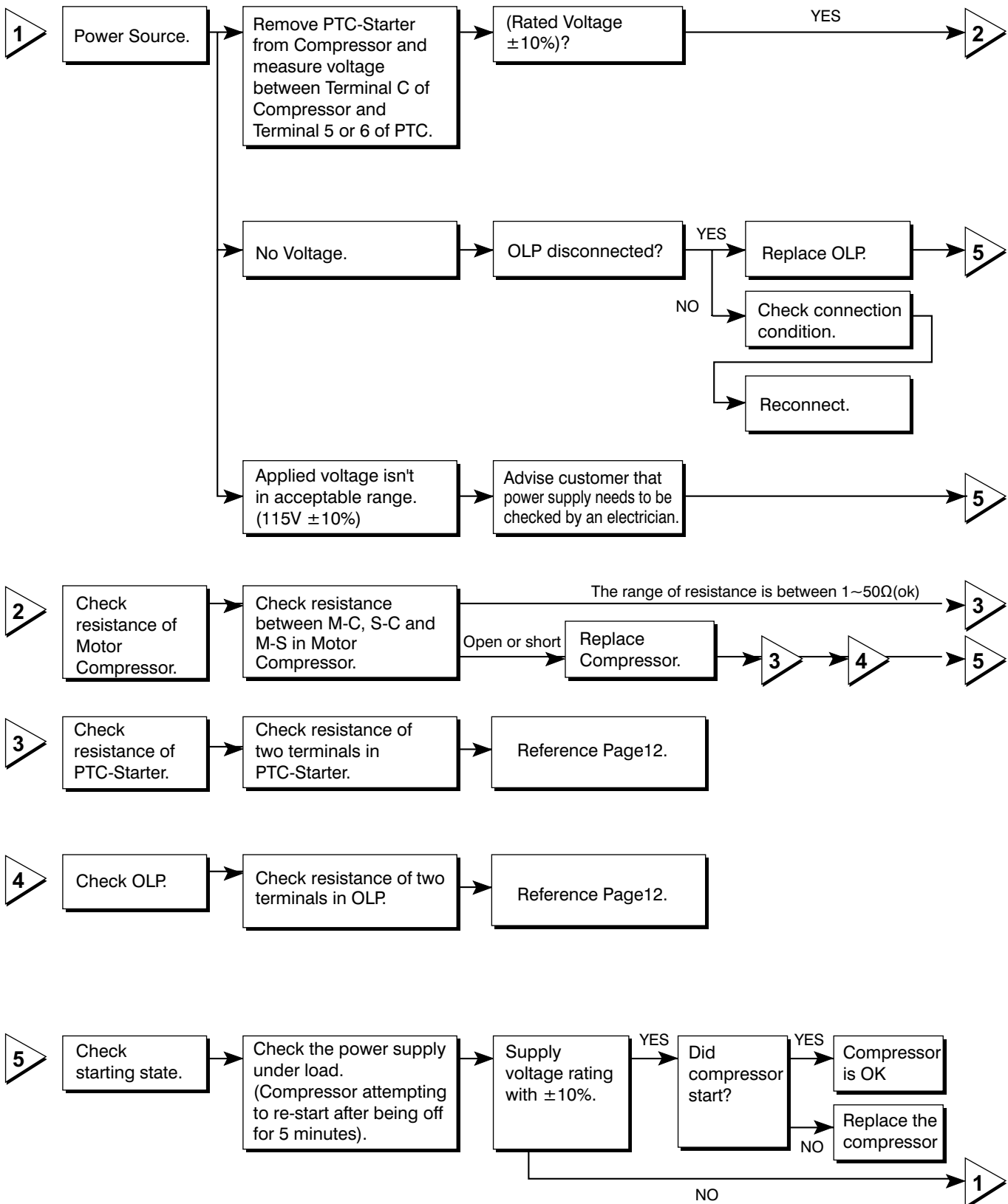

6-2 PTC AND OLP

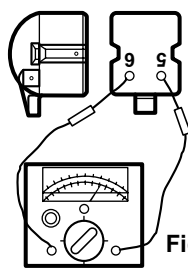
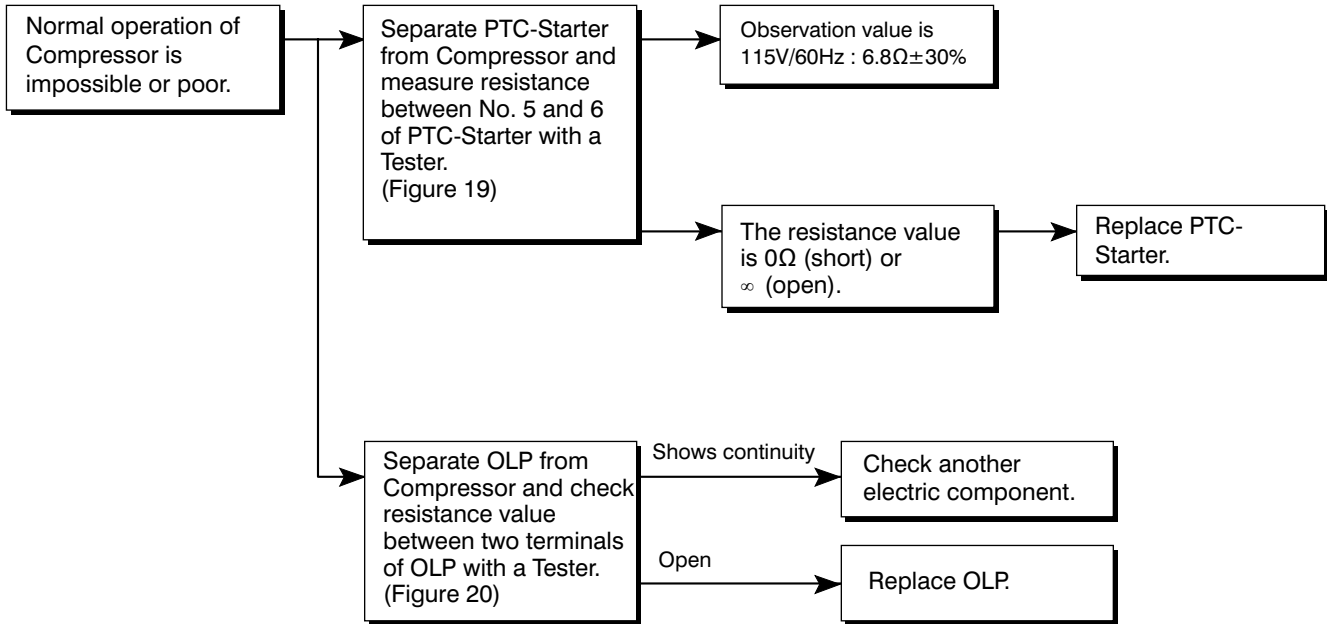

Figure 19

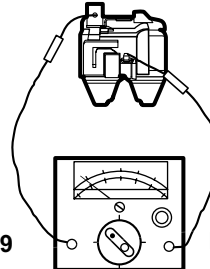
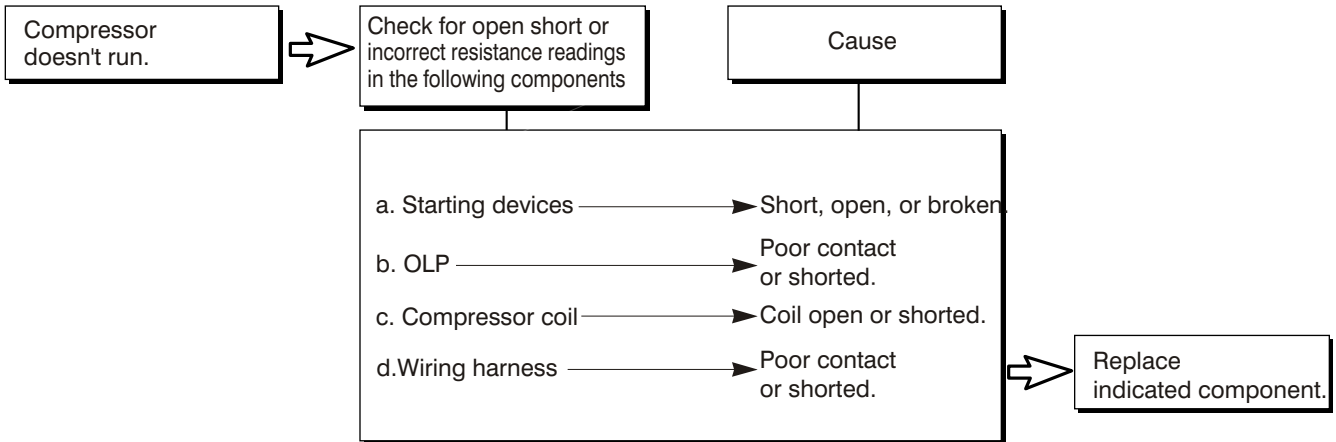

Figure 20

6-3 OTHER ELECTRICAL COMPONENTS

• **Not cooling at all**



• **Poor cooling performance**

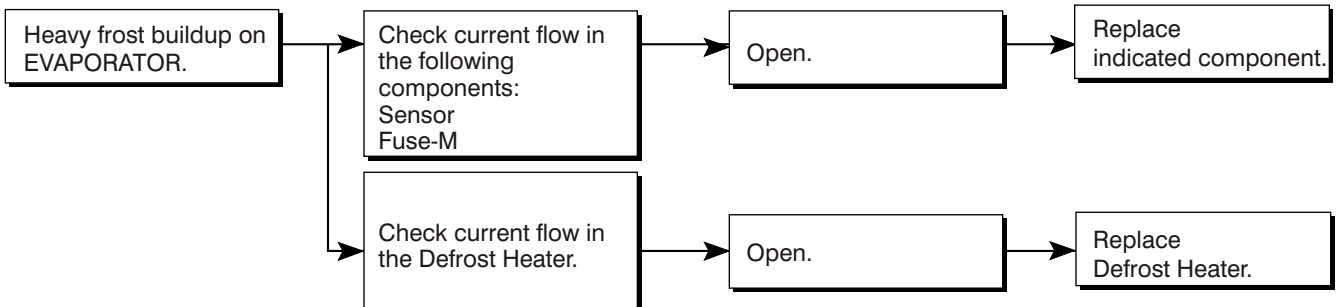
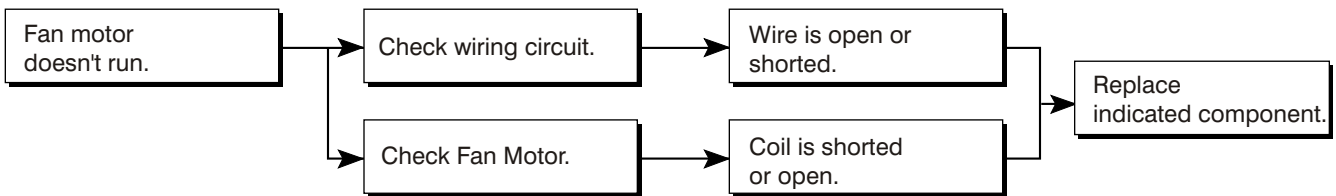
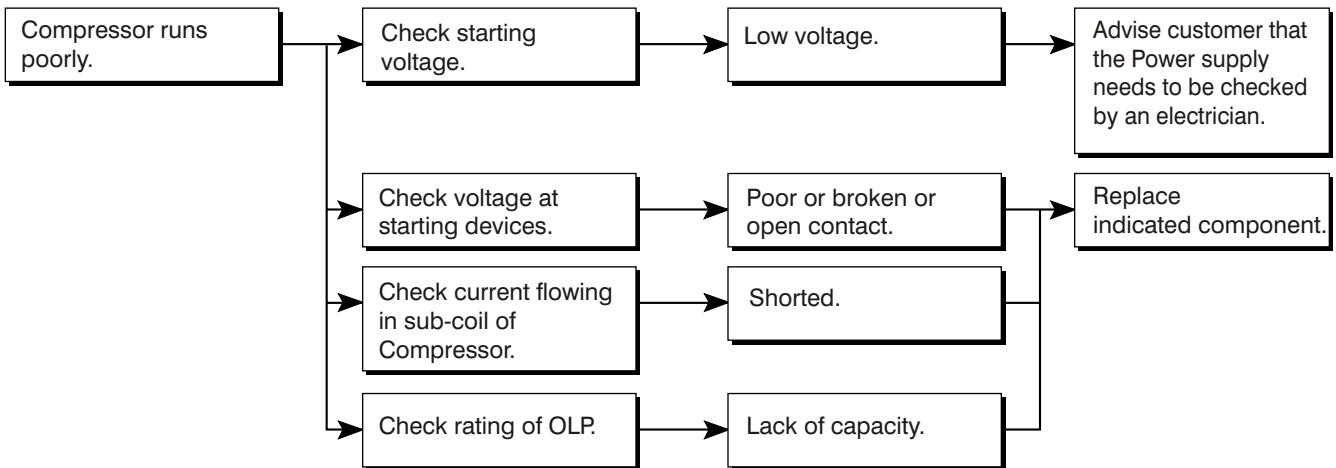

6-4 SERVICE DIAGNOSIS CHART

COMPLAINT	POINTS TO BE CHECKED	REMEDY
No Cooling.	<ul style="list-style-type: none"> Is the power cord unplugged from the outlet? Check if the power switch is set to OFF. Check if the fuse of the power switch is shorted. Measure the voltage of the power outlet. 	<ul style="list-style-type: none"> Plug into the outlet. Set the switch to ON. Replace the fuse. If the voltage is low, correct the wiring.
Cools poorly.	<ul style="list-style-type: none"> Check if the unit is placed too close to the wall. Check if the unit is placed too close to the stove, gas cooker, or in direct sunlight. Is the ambient temperature too high or the room door closed? Check if food put in the refrigerator is hot. Did you open the door of the unit too often or check if the door is sealed properly? Check if the Control is set to Warm position. 	<ul style="list-style-type: none"> Place the unit about 4 inches (10 cm) from the wall. Place the unit away from these heat sources. Lower the ambient temperature. Put in foods after they have cooled down. Don't open the door too often and close it firmly. Set the control to Recommended position.
Food in the Refrigerator is frozen.	<ul style="list-style-type: none"> Is food placed in the cooling air outlet? Check if the control is set to colder position. Is the ambient temperature below 5°C? 	<ul style="list-style-type: none"> Place foods in the high-temperature section. (front part) Set the control to Recommended position. Set the control to Warm position.
Condensation or ice forms inside the unit.	<ul style="list-style-type: none"> Is liquid food sealed? Check if food put in the refrigerator is hot. Did you open the door of the unit too often or check if the door is sealed properly? 	<ul style="list-style-type: none"> Seal liquid foods with wrap. Put in foods after they have cooled down. Don't open the door too often and close it firmly.
Condensation forms in the Exterior Case.	<ul style="list-style-type: none"> Check if the ambient temperature and humidity of the surrounding air are high. Is there a gap in the door gasket? 	<ul style="list-style-type: none"> Wipe moisture with a dry cloth. It will disappear in low temperature and humidity. Fill up the gap.
There is abnormal noise.	<ul style="list-style-type: none"> Is the unit positioned in a firm and even place? Are any unnecessary objects placed in the back side of the unit? Check if the Drip Tray is not firmly fixed. Check if the cover of the compressor enclosure in the lower front side is taken out. 	<ul style="list-style-type: none"> Adjust the Leveling Screw, and position the refrigerator in a firm place. Remove the objects. Fix the Drip Tray firmly in the original position. Place the cover in its original position.
Door does not close well.	<ul style="list-style-type: none"> Check if the door gasket is dirty with an item like juice. Is the refrigerator level? Is there too much food in the refrigerator? 	<ul style="list-style-type: none"> Clean the door gasket. Position in a firm place and level the Leveling Screw. Make sure food stored in shelves does not prevent the door from closing.
Ice and foods smell unpleasant.	<ul style="list-style-type: none"> Check if the inside of the unit is dirty. Are foods with a strong odor unwrapped? The unit smells of plastic. 	<ul style="list-style-type: none"> Clean the inside of the unit. Wrap foods that have a strong odor. New products smell of plastic, but this will go away after 1-2 weeks.

•Other possible problems:

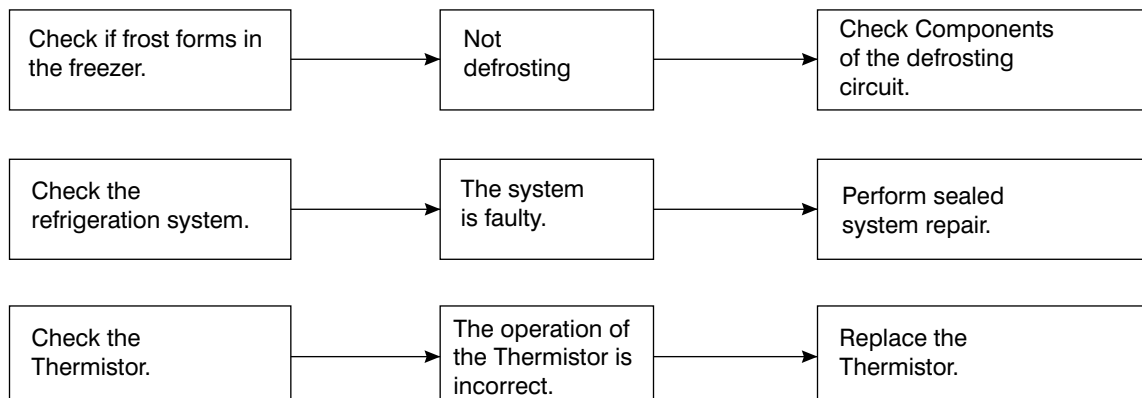

6-5 REFRIGERATION CYCLE

• Troubleshooting Chart

CAUSE		STATE OF THE UNIT	STATE OF THE EVAPORATOR	TEMPERATURE OF THE COMPRESSOR	REMARKS
LEAKAGE	PARTIAL LEAKAGE	Freezer compartment and Refrigerator don't cool normally.	Low flowing sound of Refrigerant is heard and frost forms in inlet only.	A little higher than ambient temperature.	<ul style="list-style-type: none"> • Refrigerant level is low due to a leak. • Normal cooling is possible by restoring the normal amount of refrigerant and repairing the leak.
	COMPLETE LEAKAGE	Freezer compartment and Refrigerator don't cool normally.	Flowing sound of refrigerant is not heard and frost isn't formed.	Equal to ambient temperature.	<ul style="list-style-type: none"> • No discharging of Refrigerant. • Normal cooling is possible by restoring the normal amount of refrigerant and repairing the leak.
CLOGGED BY DUST	PARTIAL CLOG	Freezer compartment and Refrigerator don't cool normally.	Flowing sound of refrigerant is heard and frost forms in inlet only.	A little higher than ambient temperature.	<ul style="list-style-type: none"> • Normal discharging of the refrigerant. • The capillary tube is faulty.
	WHOLE CLOG	Freezer compartment and Refrigerator don't cool.	Flowing sound of refrigerant is not heard and frost isn't formed.	Equal to ambient temperature.	<ul style="list-style-type: none"> • Normal discharging of the Refrigerant.
MOISTURE CLOG		Cooling operation stops periodically.	Flowing sound of refrigerant is not heard and frost melts.	Lower than ambient temperature.	<ul style="list-style-type: none"> • Cooling operation restarts when heating the inlet of the capillary tube.
DEFECTIVE COMPRESSION	COMP-RESSION	Freezer and Refrigerator don't cool.	Low flowing sound of refrigerant is heard and frost forms in inlet only.	A little higher than ambient temperature.	<ul style="list-style-type: none"> • Low pressure at high side of compressor due to low refrigerant level.
	NO COMP-RESSION	No compressing operation.	Flowing sound of refrigerant is not heard and there is no frost.	Equal to ambient temperature.	<ul style="list-style-type: none"> • No pressure in the high pressure part of the compressor.

6-5-1 SEALED SYSTEM DIAGNOSIS

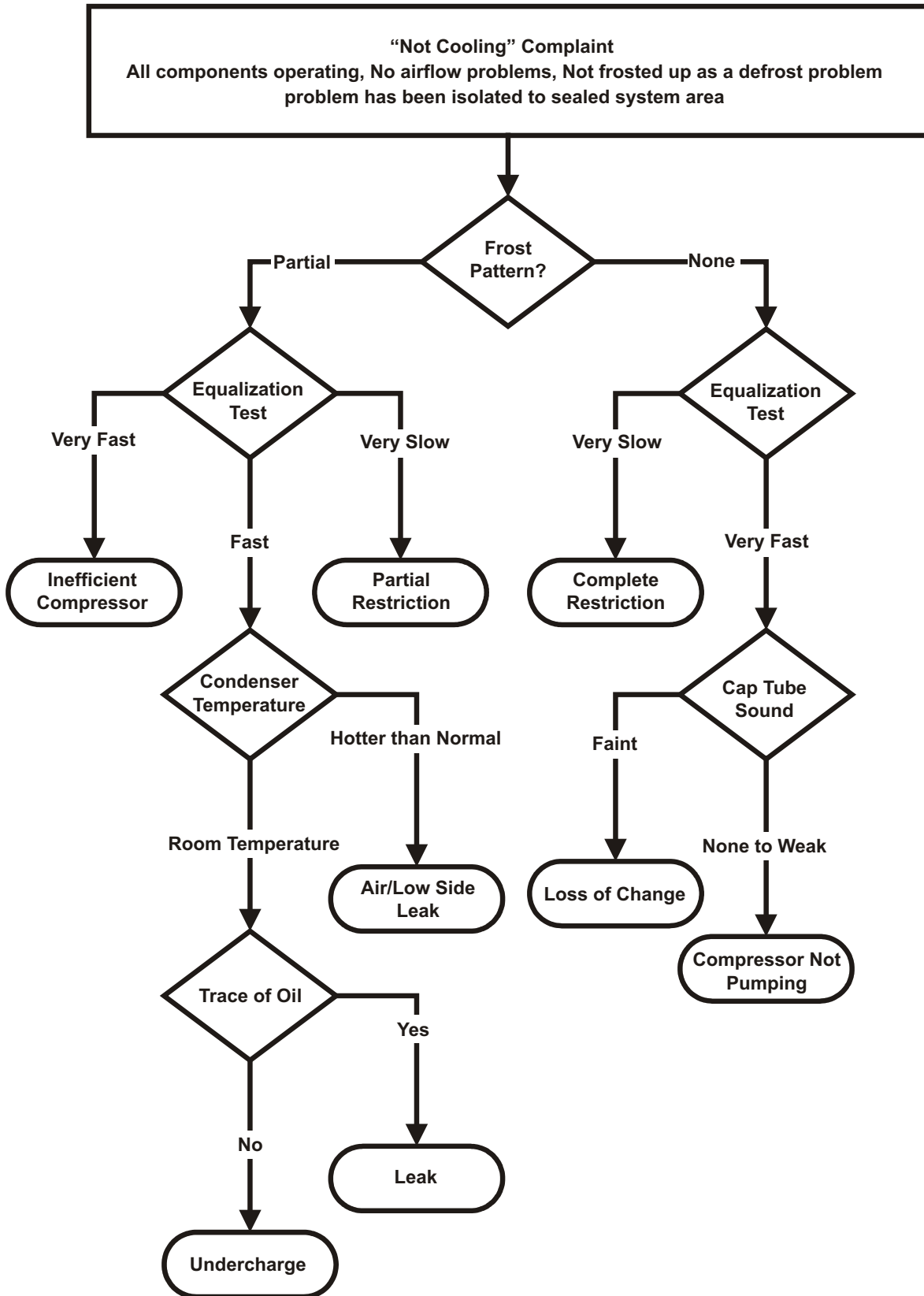

(The equalization test is trying to restart a compressor using a start kit after it has been operating.)

7. OPERATION PRINCIPLE AND REPAIR METHOD OF ICEMAKER

7-1 OPERATION PRINCIPLE

7-1-1 Operation Principle of Icemaker

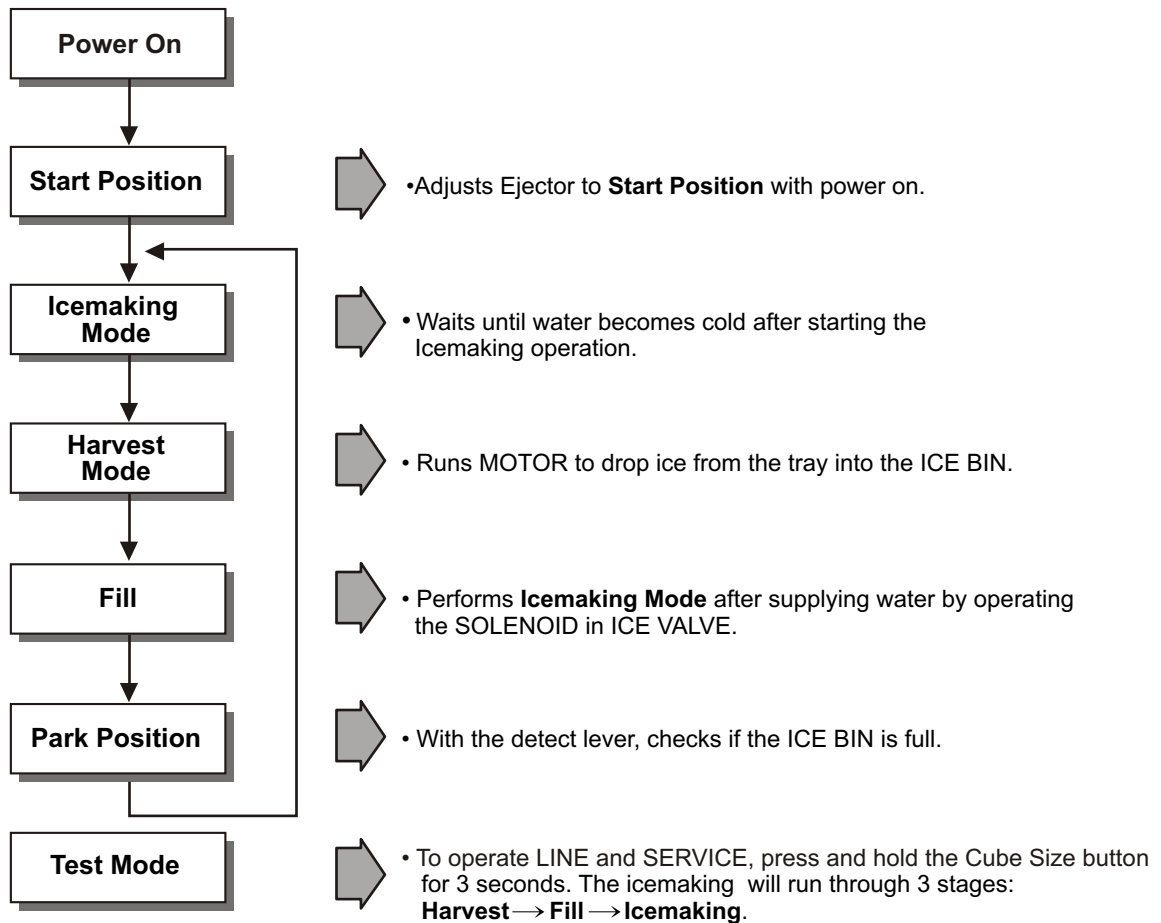

1. Turning the Icemaker stop switch off (O) stops the icemaking function.
2. Setting the Icemaker switch to OFF and then turning it back on will reset the icemaker control.

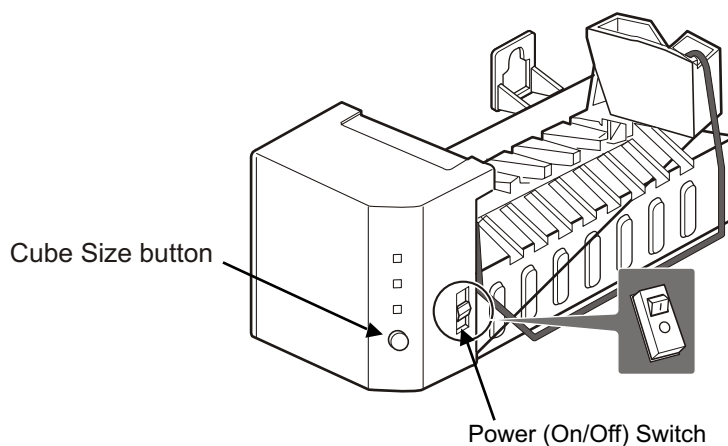

7-2 ICE MAKER FUNCTIONS

7-2-1 Ice Making Mode

1. Icemaking refers to the freezing of supplied water in the ice trays. Complete freezing is assured by measuring the temperature of the Tray with icemaking SENSOR.
2. Icemaking starts after completion of the water fill operation.
3. The icemaking function is completed when the sensor reaches -7°C, 60 to 240 minutes after starting.

NOTE : After icemaker power is ON, the icemaker heater will be on for test for 9 sec.

7-2-2 Harvest Mode



1. Harvest (Ice removing) refers to the operation of dropping ices into the ice bin from the tray when icemaking has completed.
2. Harvest mode:
 - (1) The Heater is ON for 30 seconds, then the motor starts.
 - (2) Harvest mode is completed if it reaches start position again while Heater & Motor are on at the same time.
 - A. ice bin is full : The EJECTOR stops (heater off).
 - B. ice bin is not full : The EJECTOR rotates twice to open for ice.

NOTE : If the EJECTOR does not rotate once within 5 minutes in status (2), separate heater control mode starts operating to prevent the EJECTOR from being constrained. (It is recommended that the user open for ice to return to normal mode.)

7-2-3 Fill/Park Position

1. Once a normal harvest mode has been completed, the water solenoid will be activated.
2. The amount of water is adjusted by pressing the fill key repeatedly. This changes the time allowed for fill as illustrated in the table below.





Water supply amount table

STAGE	TIME TO SUPPLY	INDICATIONS	REMARKS
1	6 sec.		The water amount will vary depending on the water control switch setting, as well as the water pressure of the connected water line.
2	7 sec.		
3	8 sec.		

7-2-5 Function TEST



1. This is a compulsory operation for test, service, cleaning, etc. It is operated by pressing and holding the Cube Size button for 3 seconds.
2. The test works only in the Icemaking Mode. It cannot be entered from the Harvest or Fill mode. (If there is an ERROR, it can only be checked in the TEST mode.)
3. **Caution!** If the test is performed before water in the icemaker is frozen, the ejector will pass through the water. When the fill mode begins (Stage 4), unless the water supply has been shut off, added water will overflow into the ice bin. If the control Doesn't operate normally in the TEST mode, check and repair as needed.
4. After water is supplied, the normal CYCLE is followed: **icemaking** ⇔ **Harvest** ⇔ **Fill** ⇔ **Park Position**.
5. Five seconds after Stage 5 is completed, the icemaker returns to MICOM control. The time needed to supply water resets to the pre- test setting.

Diagnosis TABLE

STAGE	ITEMS	INDICATOR *	REMARKS
1	HEATER		Five seconds after heater starts, heater will go off if temperature recorded by sensor is 10°C (50°F) or lever is in up position.
2	MOTOR		Five seconds after heater starts, you can confirm that motor is moving.
3	HALL IC (TRAY)		You can confirm Hall IC detection of position.
4	SOLENOID VALVE		Two seconds after detection of initial position, you can confirm that valve is on.
5	HALL IC (LEVER)		You can check when the Hall IC is sensing a full ice condition. (If there is a water fill error, the fifth LED is not on.)
6	Reset	Return to Status prior to TEST MODE	Five seconds after fifth stage is completed, the icemaker resets to initial status.

7-3 DEFECT DIAGNOSIS FUNCTION

7-3-1 ERROR CODES shown on Ice Maker water supply control panel

NO	DIVISION	INDICATOR	PROBLEM	REMARKS
1	Normal	Note fill times (see previous page)	None	Display switch operates properly
2	Icemaking Sensor malfunction		Open or shorted wire or sensor	Make sure that the wire on each sensor is connected.
3	Icemaker Kit malfunction		Ejector blades have not reached the park position after 18 minutes from start of harvest mode	Check HALL IC/MOTOR/HEATER/RELAY

* ERROR indicators in table can be checked only in TEST mode.

8. DESCRIPTION OF FUNCTION & CIRCUIT OF MICOM

8-1 FUNCTION

8-1-1 Function

1. When the appliance is plugged in, it is set to "4" for Refrigerator and "4" for freezer.
You can adjust the Refrigerator and the Freezer control temperature by pressing the ADJUST button.
2. When the power is initially applied or restored after a power failure, it is automatically set to "4" & "4".



8-1-2 Control of freezer fan motor

1. Freezer fan motor has high and standard RPMs.
2. High RPM is used when electricity is first on, for ICE PLUS, and when refrigerator is overloaded.
But standard RPM is used for general purposes.
3. To improve cooling speed and load corresponding speed, the RPM of freezer fan motor shall change from normal speed to high speed.
4. High speed (2500RPM) : Initial power on or load corresponding operation, ICE PLUS.
Normal speed (2200 RPM): general working conditions.
5. Fan motor is stopped when Refrigerator Door is Opened.
6. The fan motor is stopped when Freezer Door is Opened (only if compressor status is OFF)

8-1-3 ICE PLUS

1. The purpose of this function is to intensify the cooling speed of freezer and to increase the amount of ice.
2. Whenever selection switch is pressed, selection/release, the LED will turn ON or OFF.
3. If there is a power cut and the refrigerator is power on again, ICE PLUS function will be canceled.
4. To activate these function you need to press the ICE PLUS key and the LED will turn ON. This function will remain activated for 24 hrs. The first three hours the compressor and ICE PLUS will be ON. The next 21 hours the freezer will be controlled at the lowest temperature. After 24 hours or if the ICE PLUS key is pressed again, the freezer will return to its previous temperature.
5. For the first three hours notice the following cases:
 - (1) Compressor and freezer fan(HIGH RPM) continuously operate for three hours.
 - (2) If defrost starts during ICE PLUS, ICE PLUS operates for the rest of time after defrost is completed, when ICE PLUS operation time is less than 90 minutes.
If ICE PLUS operates for more than 90 minutes, the ICE PLUS will operate for two hours after defrost is completed.
 - (3) If ICE PLUS is pressed during defrost, ICE PLUS LED is on but this function will start seven minutes after defrost is completed and it shall operate for three hours.
 - (4) If ICE PLUS is selected within seven minutes after compressor has stopped, the compressor (compressor delays seven minutes) shall start after the balance of the delay time.
 - (5) The fan motor in the freezer compartment rotates at high speed during ICE PLUS.
6. For the rest of 21 hours, the freezer will be controlled at the lowest temperature.

8-1-4. REFRIGERATOR LAMP AUTO OFF

1. To protect the risk of lamp heat, when Refrigerator door opens for 7 min., refrigerator lamp is auto off.

8-1-5 Alarm for Open Door

1. This feature sounds a buzzer when the freezer or refrigerator door is not closed within 1 minute after it is opened.
2. One minute after the door is opened, the buzzer sounds three times each for 1/2 seconds. These tones repeat every 30 seconds.
3. The alarm is cancelled when the freezer or the refrigerator is closed while the buzzer sounds.

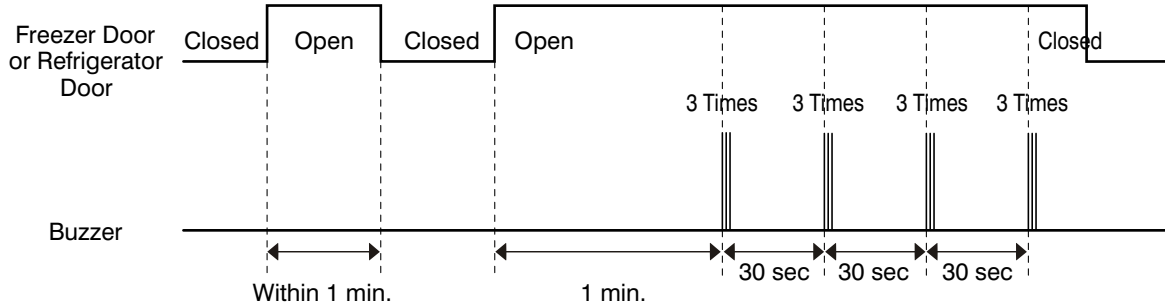

8-1-6 Buzzer Sound

When the button on the front Display is pushed, a Ding~ Dong~ sound is produced.
(Refer to the Buzzer Circuit 8-2-4 No. 3)

8-1-7 Defrosting (removing frost)

1. Defrosting starts each time when compressor running time reach 7 hours, if any door hasn't been opened
2. In case of any Door has been opened the defrosting period will start considering the next conditions:
If Compressor running time is bigger than 7 hrs when door is opened: Defrosting starts immediately.
If compressor running time is less than 7 hours when door is opened: Defrosting starts after a compensation time is applied
3. For initial power on or for restoring power, defrosting starts when the compressor running time reaches 4 hours.
4. Defrosting stops if the sensor temperature reaches 46.4°F(8°C) or more. If the sensor doesn't reach 46.4°F(8°C) in 2 hours, the defrost mode is malfunctioning. (Circuit 8.1.9)
5. Defrosting won't function if its sensor is defective (wires are cut or short circuited)

8-1-8 Electrical Parts Are Turned On Sequentially

Electrical parts such as COMP, defrosting heater, freezer FAN, etc. are turned on in the following order to prevent noise and parts damage. Several parts are started at the same time at initial power on and are turned off together when TEST is completed.

OPERATING		ORDERS				
Initial power on	Temperature of Defrosting Sensor is 45°C or more (when unit is newly purchased or when moved)	POWER ON	in 1/2 second →	COMP ON	in 1/2 second →	Freezer FAN ON
	Temperature of defrosting sensor is lower than 45°C (when power cuts, SERVICE)	POWER ON	in 1/2 second →	Defrosting heater ON	in 10 second →	Defrosting heater OFF
		in 1/2 second →	COMP ON	in 1/2 second →	Freezer FAN ON	
Reset to normal operation from TEST MODE		Total load OFF	in 7 minute →	COMP ON	in 1/2 second →	Freezer FAN ON

8-1-9 Defect Diagnosis Function

1. Automatic diagnosis makes servicing the refrigerator easy.
2. When a defect occurs, the buttons will not operate; but the tones. such as ding. will sound.
3. When defect is repaired the defect code is removed and refrigerator returns to normal operation (RESET)
4. The defect CODE is shown on the Display.

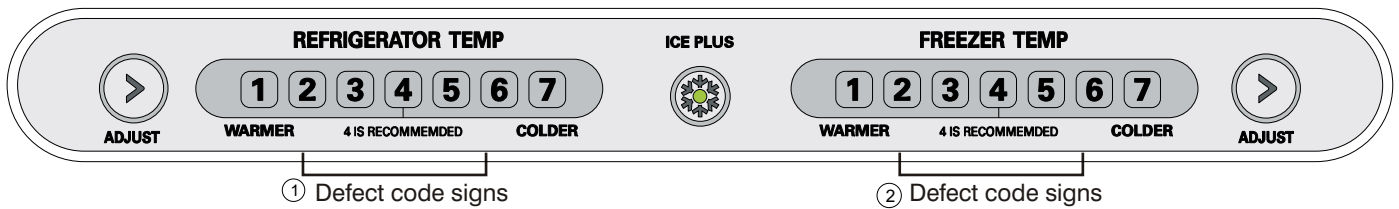

ERROR CODE on display panel

● LED OFF LED ON ○

NO	ITEM	ERROR CODE		CONTENTS	REMARKS
1	Failure of freezer sensor	All off	● ○ ○ ○ ○ ○ ○ ○	Cut or short circuit wire	Inspect Connecting wires on each sensor
2	Failure of Refrigerator sensor	All off	○ ● ○ ○ ○ ○ ○ ○	Cut or short circuit wire	
3	Failure of defrost sensor	All off	○ ○ ● ○ ○ ○ ○ ○	Cut or short circuit wire	
5	RT-sensor error (LED check mode)	All off	○ ○ ○ ● ○ ○ ○ ○ Visible in LED CHECK MODE	Open or short circuit	
4	Poor of defrost	All off	● ● ● ● ○ ○ ○	2 hours later after starting defrost, If sensor doesn't be over 46°F (8°C)	Snapping of defrost heater or Temperature fuse, pull-out of Connector (indicated minimum 2 Hours after failure occurs)
5	Failure of BLDC fan motor at freezing compartment	All off	● ● ● ● ● ○ ○	If there is no fan motor signal, for more than 65 seg. In operation fan motor.	Poor motor, hocking to wires of fan, contact of structures to fan, snapping or short of lead

DISPLAY CHECK MODE: Press at the same time ADJUST REFRIGERATOR TEMP & ADJUST FREEZER TEMP

For more than 1 second. This Mode is for LED inspection and ALL LED will turn ON at this time,

If releasing the buttons, the display will indicate the previous Status

If there is an RT sensor defect it will be indicated in this mode.

8-1-10 TEST Mode

1. The Test mode allows checking the PCB and the function of the product as well as finding out the defective part in case of an error.
2. The test mode is operated by pressing two buttons at Display panel.
3. While in the test mode, the function control button is not recognized, but the recognition tone (beep~) sounds.
4. After exiting the test mode, be sure to reset by unplugging and then plugging in the appliance.
5. If an error, such as a sensor failure, is detected while in the test mode, the test mode is cleared and the error code is displayed.
6. While an error code is displayed, the test mode will not be activated.

MODE	MANIPULATION	CONTENTS	REMARKS
TEST1	Push ICE PLUS key and ADJUST key of Freezer Temperature at the same time over 3 seconds.	<ol style="list-style-type: none"> 1. Continuous operation of the COMPRESSOR 2. Continuous operation of the freezer fan 3. STEPPING DAMPER OPEN 4. Defrosting Heater OFF 5. Every DISPLAY LED ON 	Maximum test time: 5 Minutes
TEST2	Push ICE PLUS key and ADJUST key of Freezer Temperature at the same time over 3 seconds in TEST MODE 1	<ol style="list-style-type: none"> 1. COMP OFF 2. Freezer FAN OFF 3. STEPPING DAMPER CLOSE 4. Defrosting heater ON 5. DISPLAY LED 1, 3, 5, 7 ON 	Reset if the temperature of the Defrosting sensor is 46°F (8°C) or more.
Reset	Push ICE PLUS key and ADJUST key of Freezer Temp. at the same time over 3 seconds. in TEST MODE 2	Reset to the previously setting before TEST MODE	The compressor will Start after a 7-minute delay.

* Freezer Fan RPM Variable Check:

In case the freezer fan is in operation when the ADJUST key in Refrigerator and Freezer Temp. Control are pressed for more than one second at the same time freezer fan RPM changes. (for example if high speed, to normal speed or if normal speed, to high speed for 30 seconds)
After 30 seconds, it turns to its original RPM.

* Demonstration MODE:

1. When the ICE PLUS key and ADJUST key of refrigerator temperature control are pressed for more than 3 seconds at the same time temperature's it converts to demonstration mode.
2. In this status, each LED is rotated with 1 second interval.
3. In this status, all Loads are off (Compressor / Fan / Damper / Heater)
(Even is Demonstration Mode, the refrigerator Lamp automatic off function works normally and can be demonstrated)
4. It reset if you do again as clause.

8-2 PCB FUNCTION

8-2-1 Power Circuit

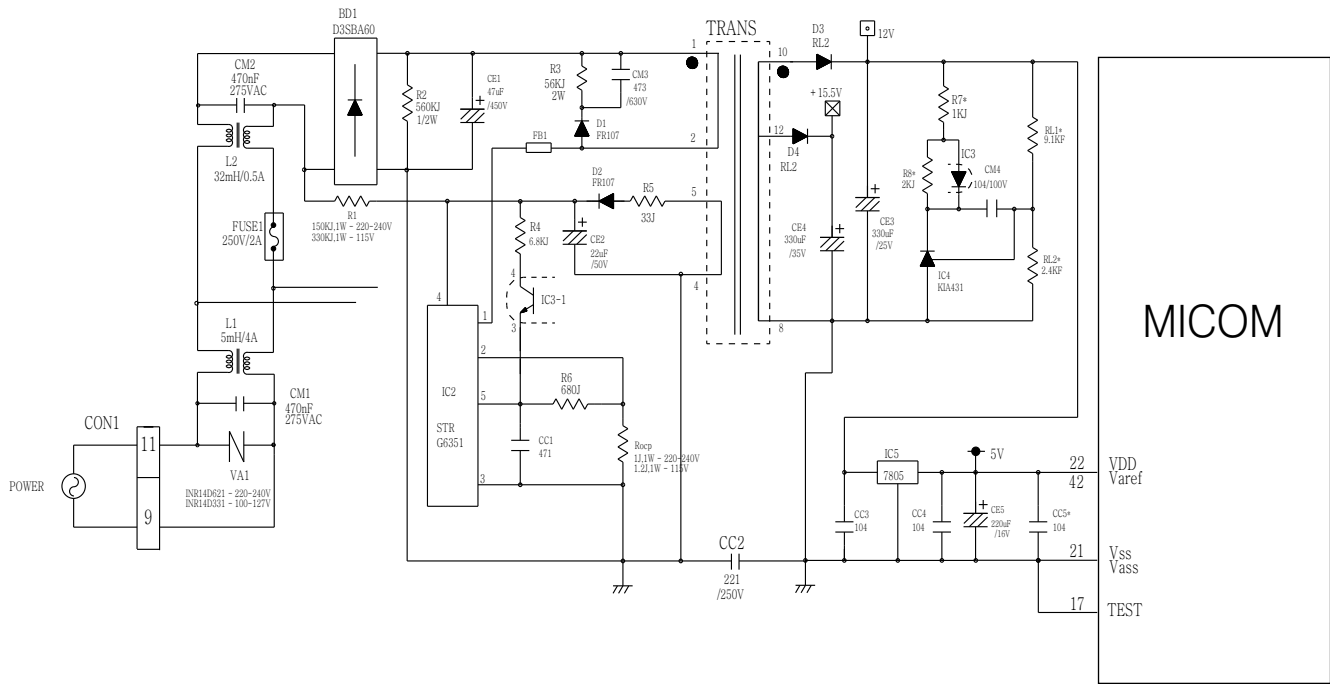

The secondary part of the TRANSFORMER is composed of the power supply for the display, the BLDC FAN Motor drive (15.5 V), the relay drive (12 Vdc) and the MICOM and IC (5 Vdc).

The voltage for each part is as follows:

PART	VA 1	CE 3	CE 4	CE 5
VOLTAGE	115 Vac	12 Vdc	15.5 Vdc	5 V

VA1 is a part for preventing over voltage and noise. When high voltage is applied, the inside elements are short-circuited and broken, resulting in blowout of the fuse in order to protect the elements of the secondary part of the TRANSFORMER.

8-2-2 Oscillation Circuit

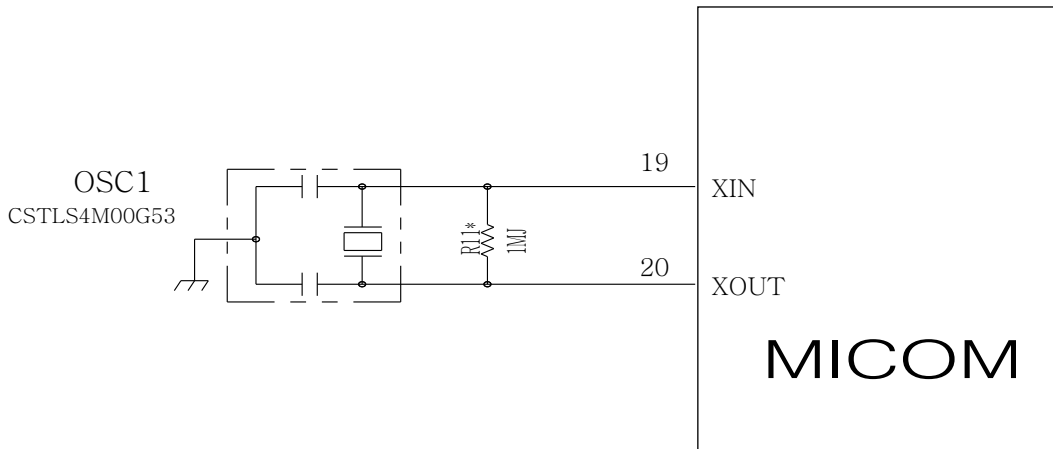

This circuit generates the base clock for calculating time and the synchro clock for transmitting data from and to the inside logic elements of the IC1 (MICOM). Be sure to use specified replacement parts, since calculating time by the IC1 may be changed. If changed, the OSC1 SPEC will not work.

8-2-3 Reset Circuit

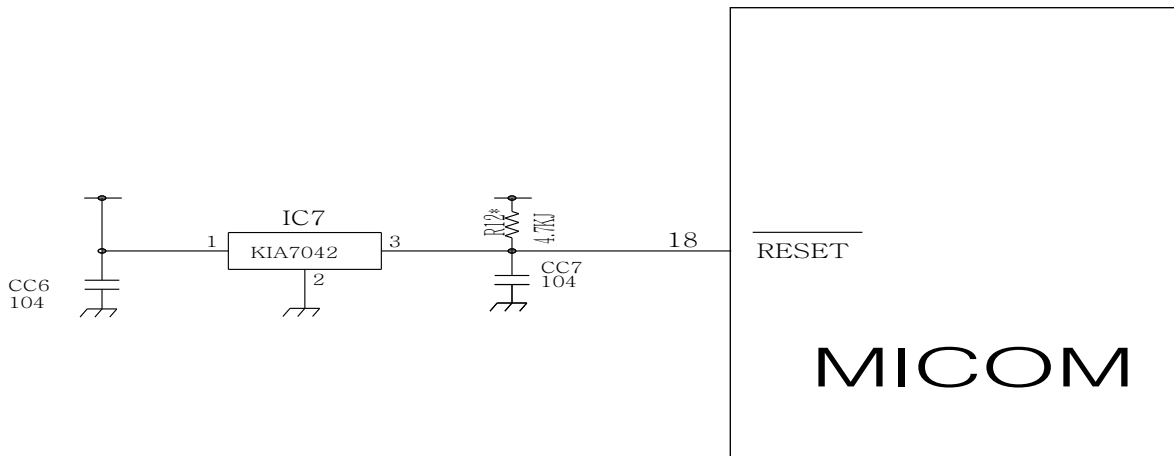

The RESET circuit allows all the functions to start at the initial conditions by initializing various parts, including the RAM inside the MICOM (IC1) when the power is initially supplied or the power supply to the MICOM is restored after a momentary power failure. For the initial 10ms of power supply, LOW voltage is applied to the MICOM RESET terminal. During a normal operation, 5V is applied to the RESET terminal. (If a malfunction occurs in the RESET IC, the MICOM will not operate.)

8-2-4 Load / Buzzer Drive & Open Door Detection Circuit

1. Load Drive Condition Check

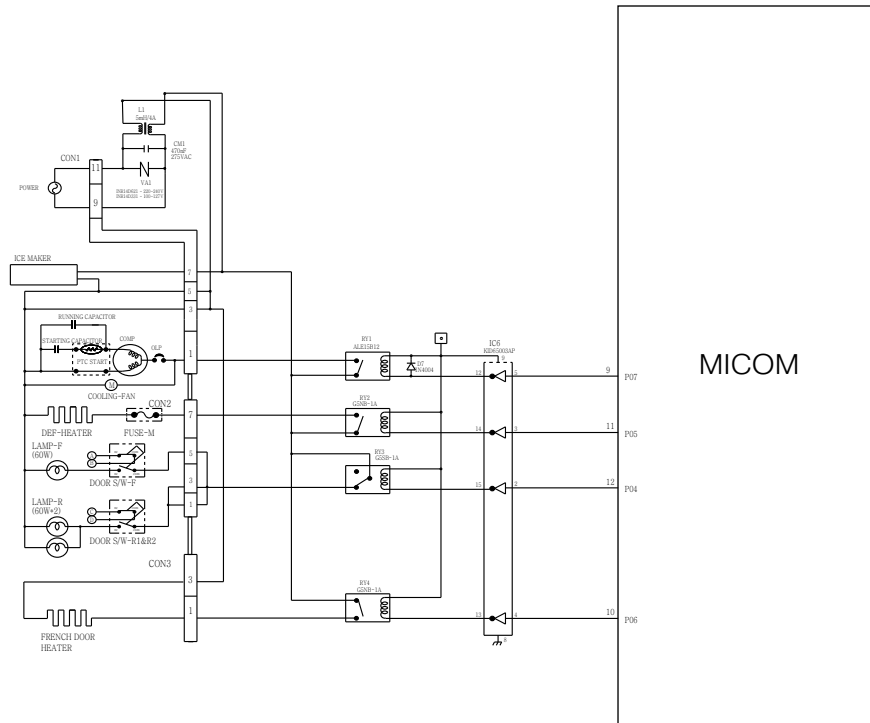

LOAD TYPE	COMP	DEFROSTING HEATER	LAMP	FRENCH DOOR HEATER 1, 2 / DEW HEATER
Measurement Location (IC6)	NO.12	NO.14	NO.15	NO.13
Condition	ON	1V or below		
	OFF	12V		

2. Fan motor driving circuit (freezing compartment fan)

1. The circuit makes the Motor Fan OFF by cutting Off the power supplied to driver inside the Fan Motor when the is necessary.
2. This is a circuit to perform a temporary change of speed for the fan motor and applies DC voltage up to 7.5V ~ 16V to motor.
3. This circuit prevents over-driving the fan motor by cutting off power applied to the fan motor in the lock of fan motor by sensing the operation RPM of the fan motor.

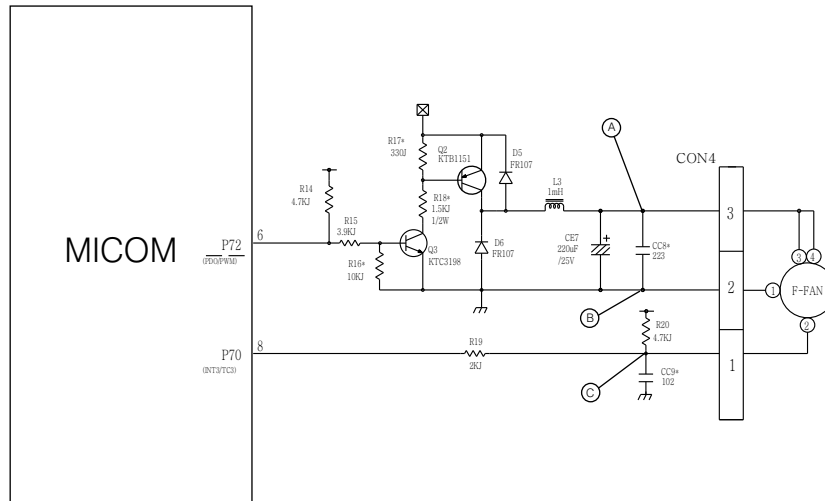

	Ⓐ part	Ⓑ part	Ⓒ part
MOTOR OFF	2V or less	0V	5V
MOTOR ON	13V~15V	0V	2V~3V

3. Buzzer Drive Condition Check

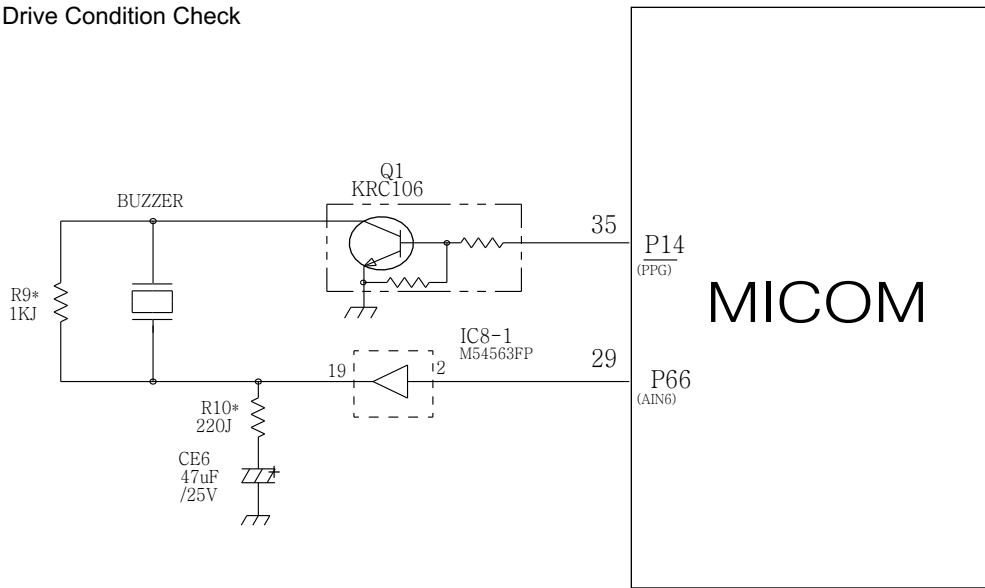

Condition Measurement Location	Tone (Ding~Dong~) when the button on the display is pushed.	Alarm for open door (beep-beep-beep)	OFF
IC1 (A)			0 V
IC1 (B)			0 V

4. Open Door Detection Circuit Check

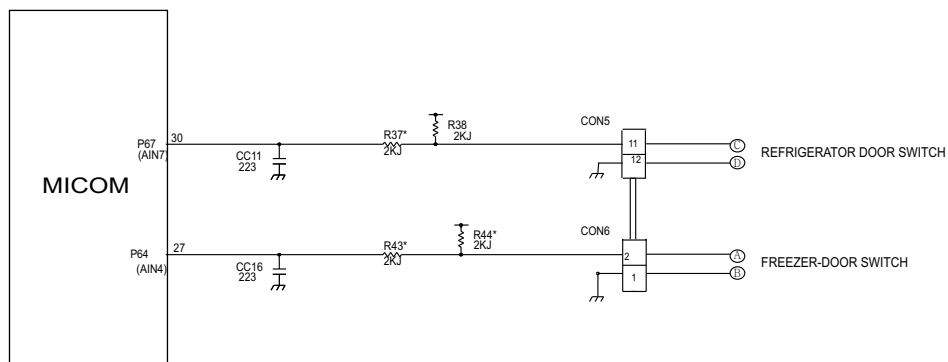

Measurement Location Freezer/ Refrigerator Door	Pin No. 1 & 2 (Freezer Door) Pin No. 11 & 12 (Refrigerator Door)
Closed	5 V
Open	0 V

8-2-5 Temperature Sensor Circuit

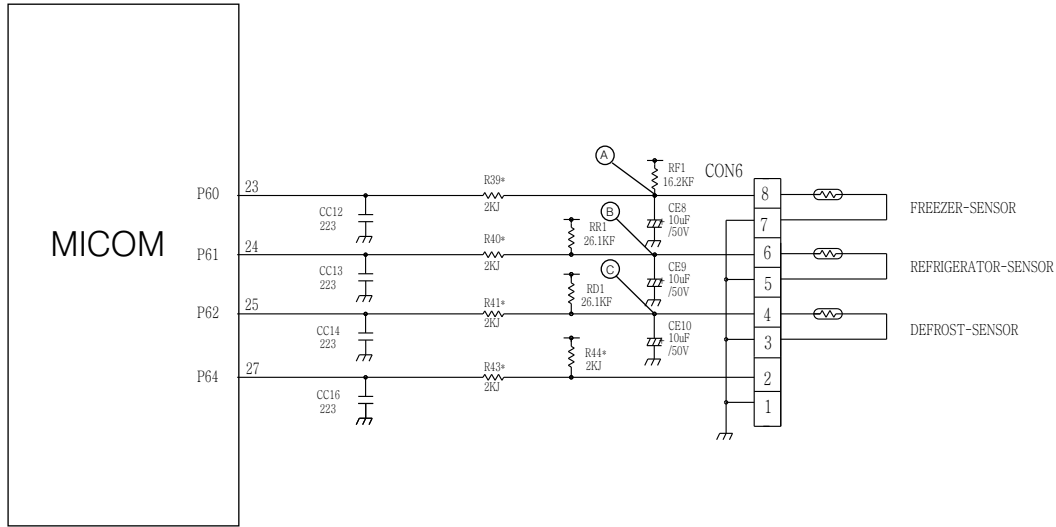

The upper CIRCUIT reads REFRIGERATOR temperature, FREEZER Temperature, and DEFROST-SENSOR temperature for defrosting and the indoor temperature for compensating for the surrounding temperature into MICOM. OPENING or SHORT state of each TEMPERATURE SENSOR are as follows:

SENSOR	CHECK POINT	NORMAL (-30°C ~ 50°C)	SHORT-CIRCUITED	OPEN
Freezer Sensor	POINT (A) Voltage	0.5 V ~ 4.5 V	0 V	5 V
Refrigerator Sensor	POINT (B) Voltage			
Defrosting Sensor	POINT (C) Voltage			

8-2-6 Refrigeration Compartment Stepping Motor Damper Circuit

* The circuit shown below is the damper circuit to regulate the refrigerator temperature.

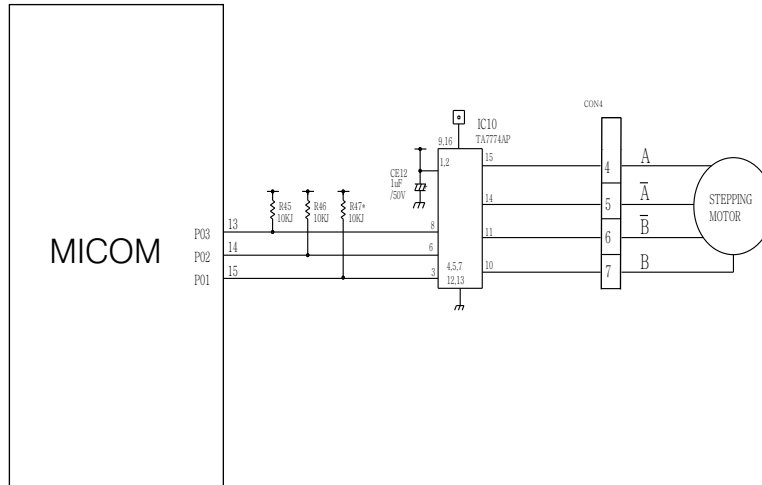

8-2-9 Key Button Input & Display Light-On Circuit

▶The circuit shown above determines whether a function control key on the operation display is pushed. It also turns on the corresponding function indication LED (LED Module) SEVEN SEGMENT DISPLAY (SEVEN SEGMENT DISPLAY MODULE). The drive type is the scan type

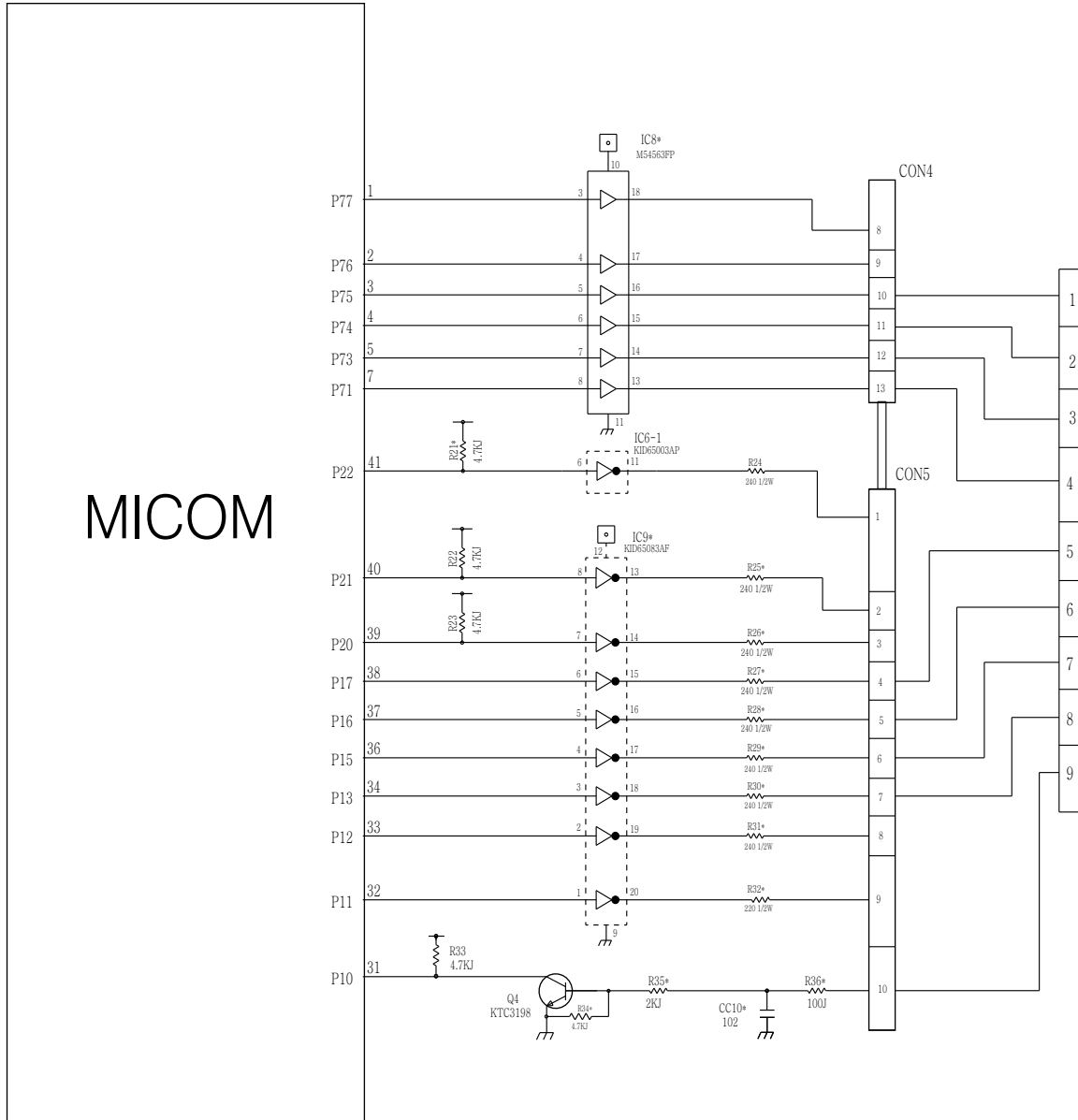

8-3 RESISTANCE SEPECIFICATION OF SENSOR

TEMPERATURE DETECTED BY SENSOR	RESISTANCE OF FREEZER SENSOR	RESISTANCE OF REFRIGERATOR & DEFROST SENSOR & ROOM SENSOR
-20° C	22.3 K Ω	77 K Ω
-15° C	16.9 K Ω	60 K Ω
-10° C	13.0 K Ω	47.3 K Ω
- 5° C	10.1 K Ω	38.4 K Ω
0° C	7.8 K Ω	30 K Ω
+ 5° C	6.2 K Ω	24.1 K Ω
+ 10° C	4.9 K Ω	19.5 K Ω
+ 15° C	3.9 K Ω	15.9 K Ω
+ 20° C	3.1 K Ω	13 K Ω
+ 25° C	2.5 K Ω	11 K Ω
+ 30° C	2.0 K Ω	8.9 K Ω
+ 40° C	1.4 K Ω	6.2 K Ω
+ 50° C	0.8 K Ω	4.3 K Ω

- The resistance of the SENSOR has a $\pm 5\%$ common difference.
- Measure the resistance of the SENSOR after leaving it for over 3 minutes in the measuring temperature. This delay is necessary due to sensor response speed.

8-4 TROUBLESHOOTING

PROBLEM	INDICATED BY	CHECK	CHECKING METHOD	CAUSE	SOLUTION		
POWER SOURCE is poor.	1. The whole DISPLAY LED/SEVEN SEGMENT DISPLAY is off. 2. DISPLAY LED/SEVEN SEGMENT DISPLAY operates abnormally	1. FREEZER/ REFRIGERATOR. 2. If LAMP is dim.	Check if FREEZER/ REFRIGERATOR DOOR IS OPEN and check display. Check visually.	POWER SOURCE is poor. Applied voltage error: CONNECTOR connection is poor.	Check outlet Voltage. Use boosting TRANS. Reconnect CONNECTOR. Replace TRANS.		
						3. The connection of the MAIN PWB CONNECTOR.	Check connection of CONNECTOR.
		COOLING is poor.	NO COOLING.	1. If the COMPRESSOR operate. 2. If refrigerant is leaking.	USE TEST MODE1 (forced COOLING). If less than 7 minutes pass after compressor shuts off, don't press the KEY and wait. Measure the amount of frost sticking on EVAPORATOR and the surface temperature of the condenser pipe.	COMPRESSOR locked or blocked. OLP, PTC is poor. COMPRESSOR RELAY is poor. THE CONNECTING WIRE is poor.	Replace COMPRESSOR. Replace OLP, PTC. Replace MAIN PWB. Check the connection of the black wire of the MAIN PWB CONNECTOR (CON2).
FREEZER TEMPERATURE is incorrect				1. If FANMOTOR operates.	Replace the FAN MOTOR.		
				2. If DEFROSTING is normal. 3. If SENSOR is normal. 4. Door Line contact.	See DEFROSTING is poor. Replace SENSOR. Replace door liner.		

PROBLEM	INDICATED BY	CHECK	CHECKING METHOD	CAUSE	SOLUTION
COOLING is poor.	If REFRIGERATOR TEMPERATURE is too low.	1. If FREEZER TEMPERATURE isn't normal.	Check if FREEZER TEMPERATURE is too low.		Make sure the DOOR is attached.
		2. If amount of cool air from FAN MOTOR is sufficient.	Make sure that the amount and speed of cool air are sufficient by touching the check supplied on the REFRIGERATOR.	FAN MOTOR is poor. Passage of cool air is blocked. EVA frozen.	Replace FAN MOTOR. Remove impurities.
		3. Door Line contact.	Check door seal when door is closed.	Door liner damaged.	Replace Door liner.
DEFROSTING is poor.	NO DEFROSTING.	1. If HEATER emits heat.	USE TEST MODE3 (forced DEFROSTING).	HEATER disconnection.	Replace HEATER.
				TEMPERATURE FUSE disconnection.	Replace TEMPERATURE FUSE.
				Connection is poor.	Check EVAPORATOR connection and wire of MAIN PWB CONNECTOR.
				DEFROST-SENSOR is poor.	Replace DEFROST-SENSOR.
				HEATER RELAY is poor.	Replace RY2 of MAIN PWB.
				DRAIN PIPE is blocked.	Remove ice and impurities. Check HEATER PLATE resistance.
		3. If ice remains after DEFROSTING.	Make sure that DEFROST SENSOR is connected. Make sure that FREEZER / REFRIGERATOR DOOR is closed.	Connection is poor.	Reassemble the DEFROST-SENSOR.
				DOOR does not close properly.	Reassemble DOOR.
					Replace GASKET.

8-5 MAIN PWB ASSEMBLY AND PARTS LIST

8-5-1 Main PWB Assembly

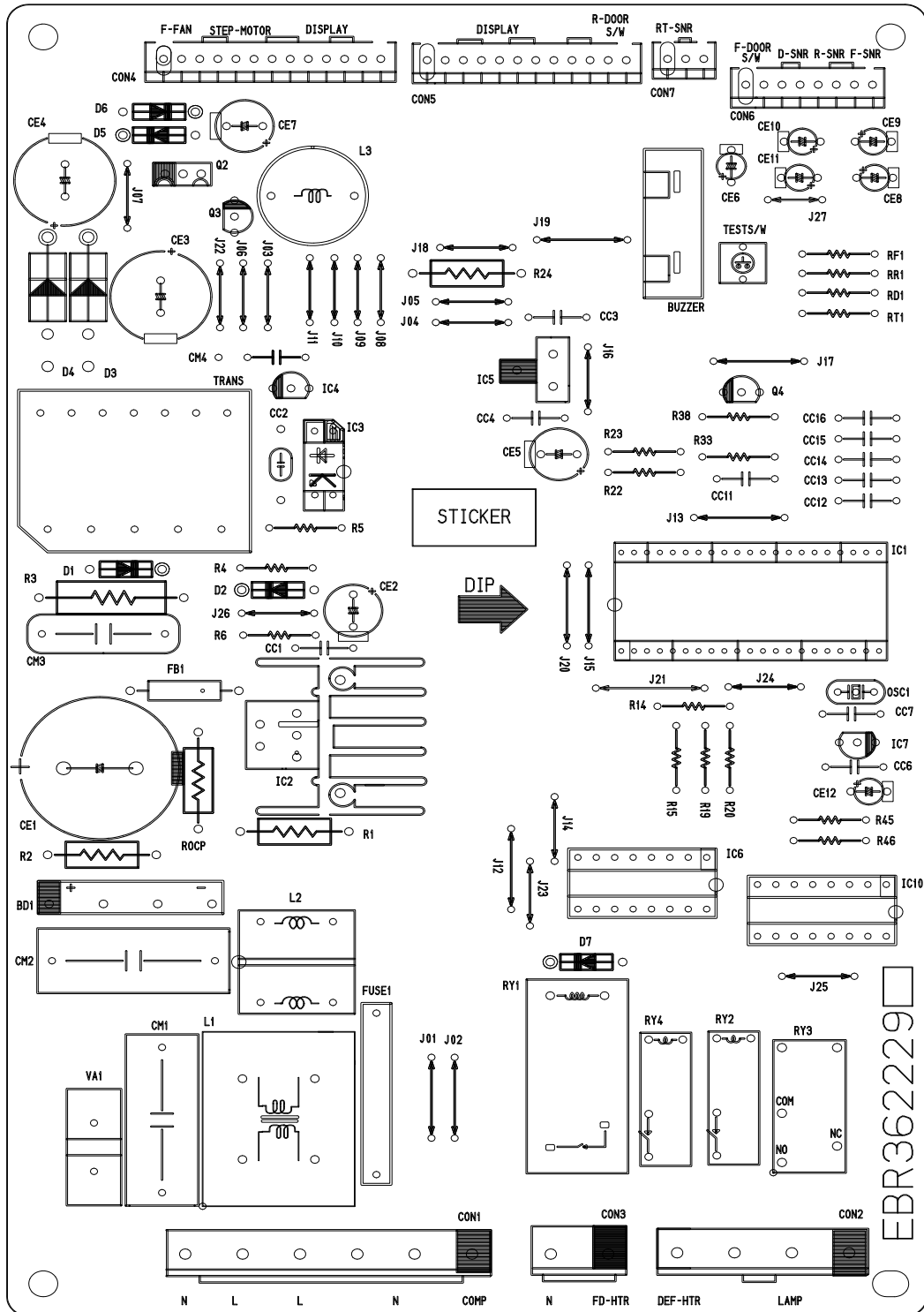

8-5-3 PWB Assembly, Display and parts list

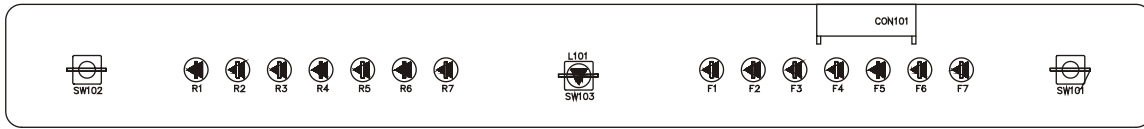

Qty	No	P/NO	DESCRIPTION	SPEC	MAKER	REMARK
1	1	6870JB8091A	PWB(PCB)	KS-PJT GOOD/BETTER DISPLAY	DOO SAN	t=1.6
	2					
1	3	6630AQ9159H	WAFER	SMAW250-09	YEON HD	CON101
	4					
2	5	6600RRT002K 6600JB8005A	SWITCH,TACT	JTP1230A JEIL 12V DC 50MA KPT-1105A	JEIL KYUNG IN	SW101,102
1	6	-	TACT S/W	KPT-1109G	KYUNG IN	SW103
14	7	0DLLE0019AA	LED	LT1824-81-BCM TP GREEN 2		R1~R7,F1~F7
3	8	0DD414809AA	DIODE,SWITCHING	1N4148 26MM	PYUNG CHANG DELTA	D101,102,103
12	10	6854B50001A	JUMP WIRE	0.6MM 52MM TP TAPING SN (10MM)	-	J101~J112
	11					
-	12	9VWF0120000	SOLDER(ROSIN WIRE) RSO	D1.20	HEE SUNG	-
001	13	49111004	SOLDER,SOLDERING	H63A	-	-
01002	14	59333105	FLUX	SG;0.825-0.830 KOREA F.H-206	KOKI	-

8-6 PWB DIAGRAM

8-6-1 PWB Main Assembly

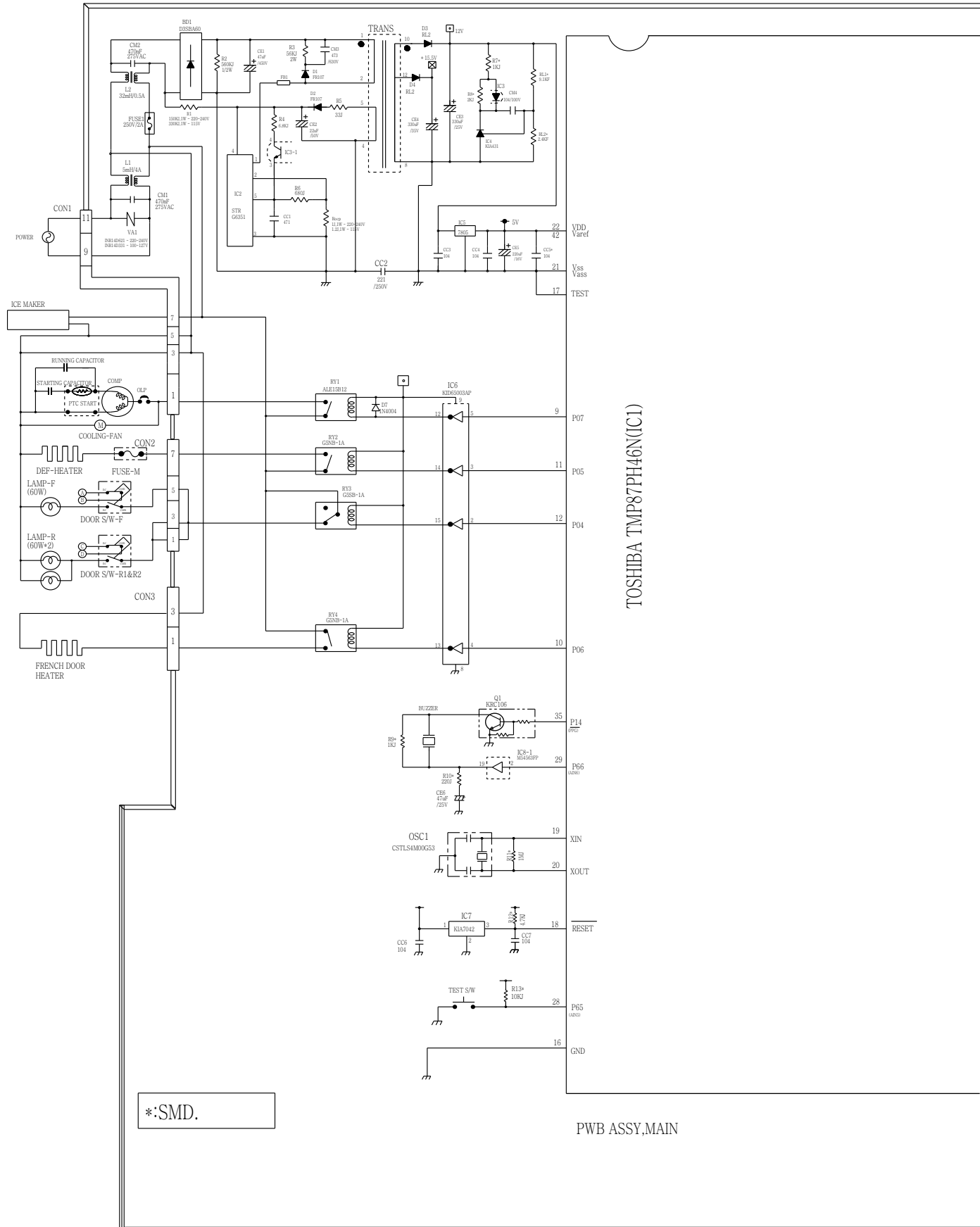

TOSHIBA TMP87PH46N(IC1)

*:SMD.

PWB ASSY.MAIN

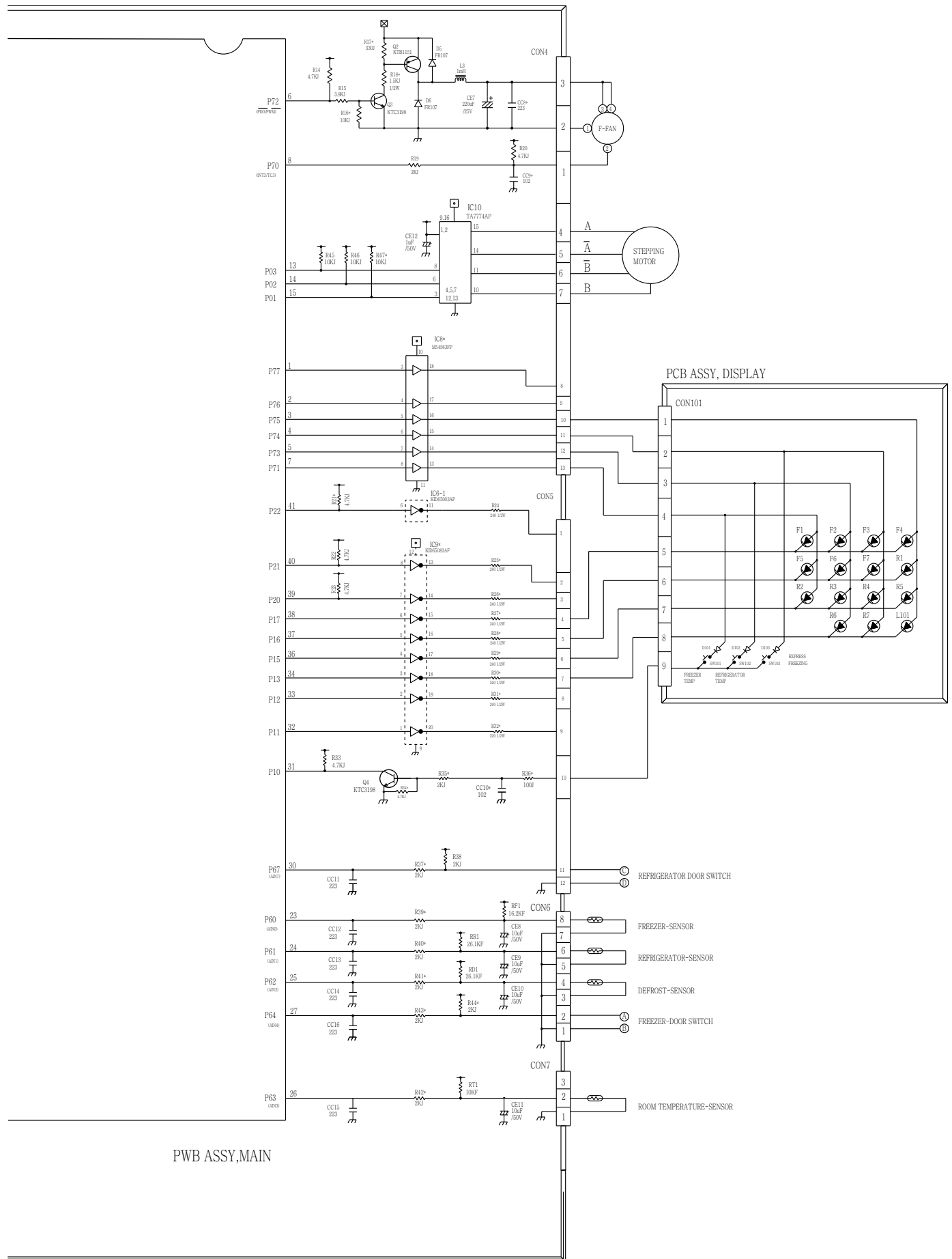

PWB ASSY,MAIN

9. EXPLODED VIEW & REPLACEMENT PARTS LIST

CASE PARTS

CAUTION: Use the part number to order part, not the position number.

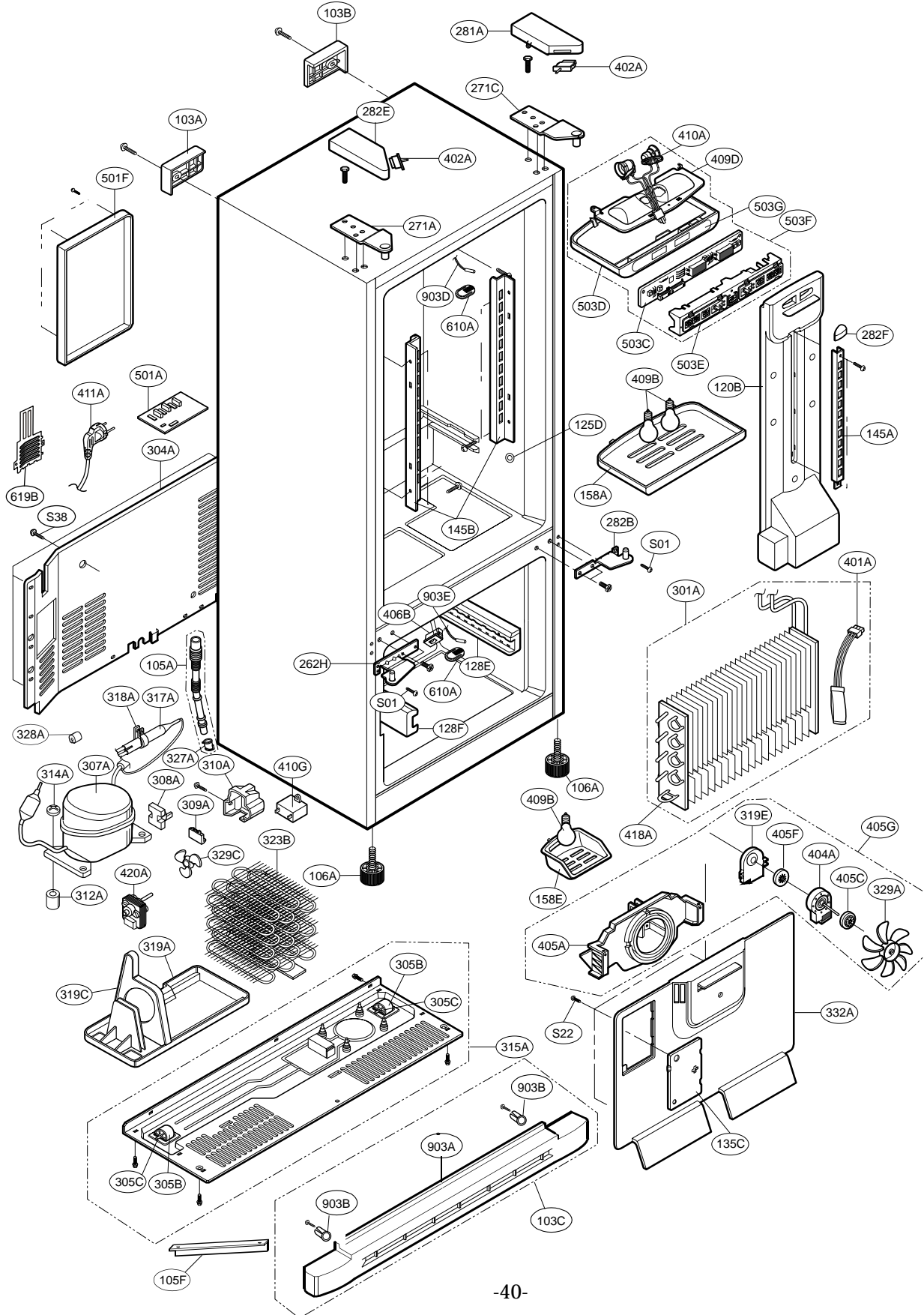

FREEZER PARTS

CAUTION: Use the part number to order part, not the position number.

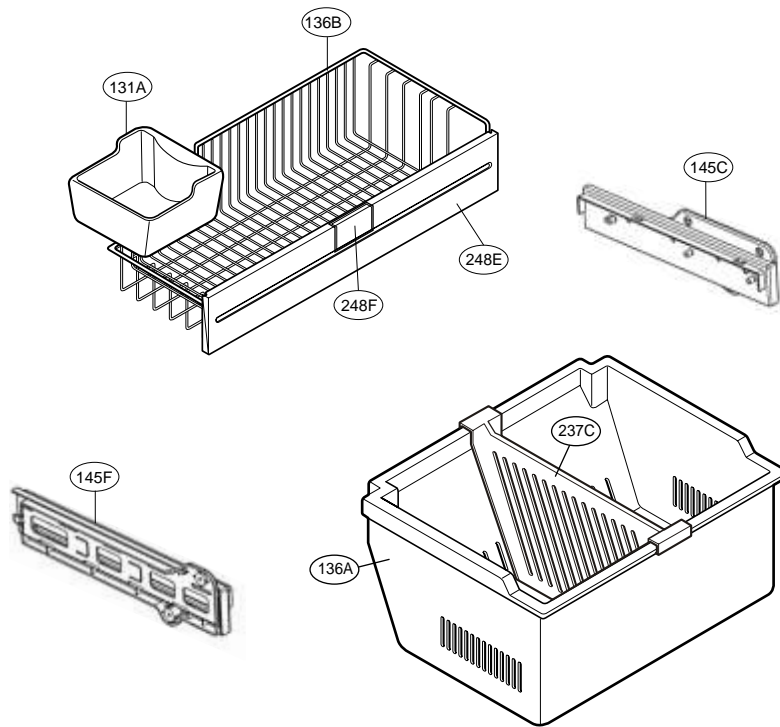

REFRIGERATOR PARTS

CAUTION: Use the part number to order part, not the position number.

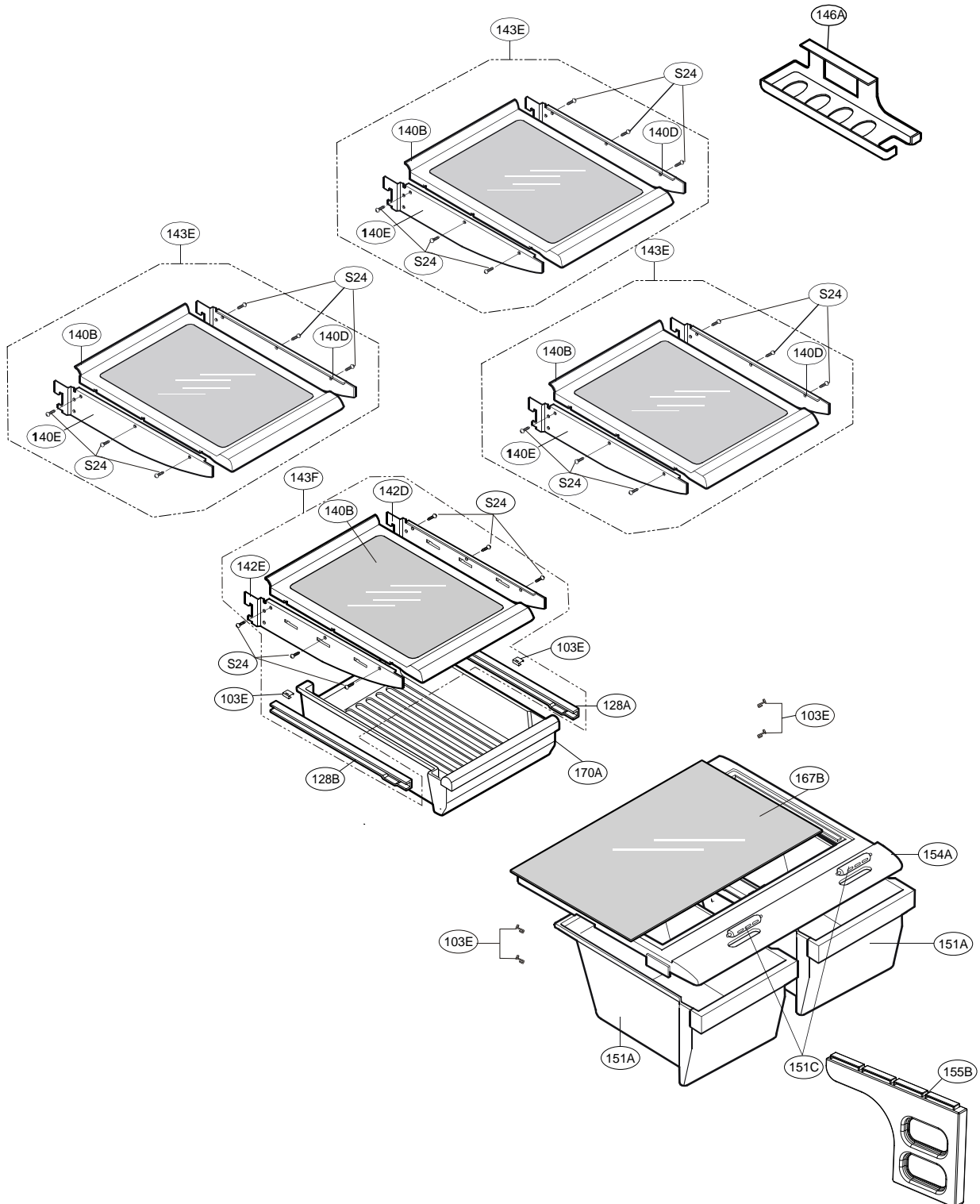

DOOR PARTS

CAUTION: Use the part number to order part, not the position number.

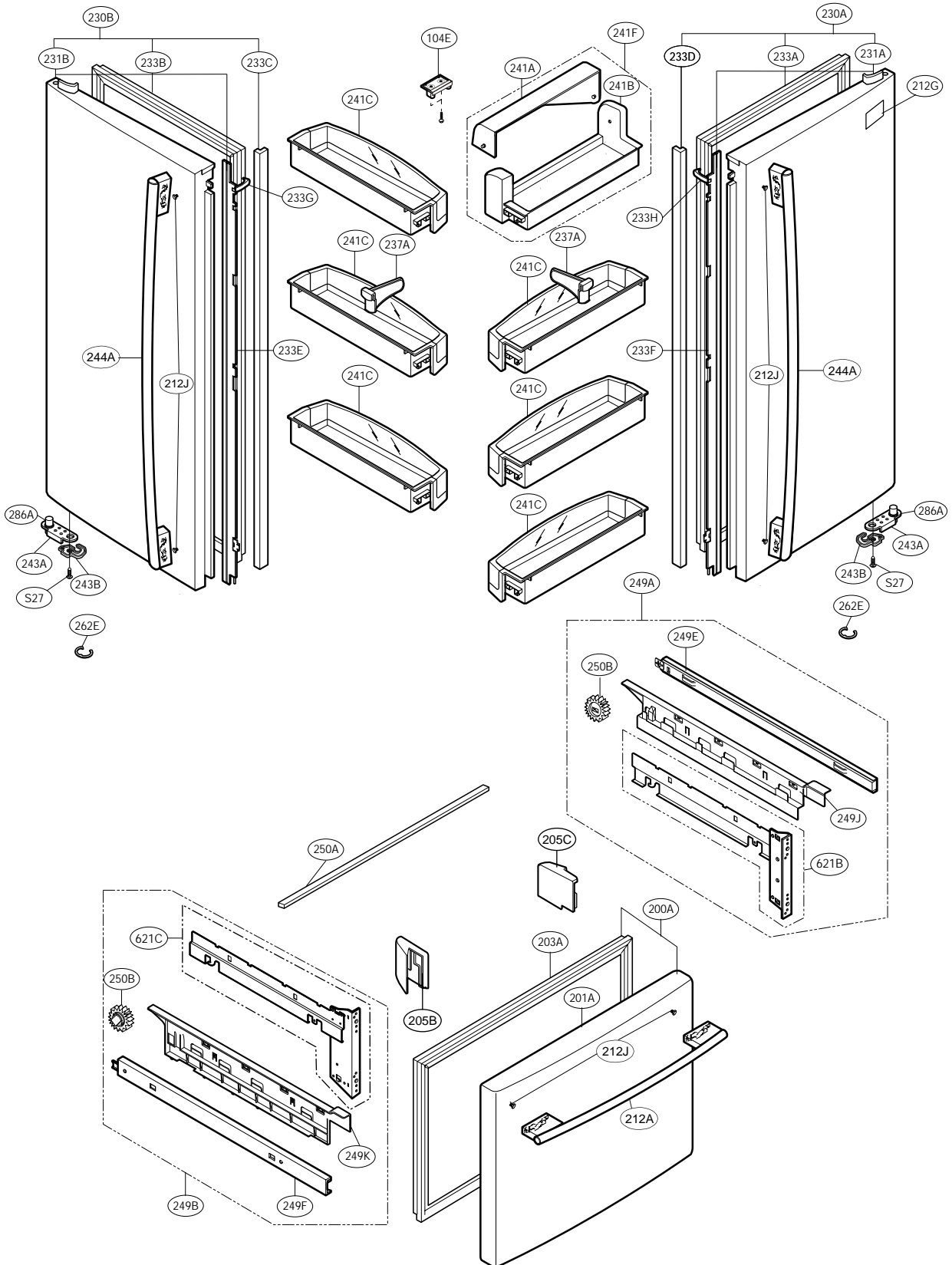

* Only on some models

WATER and ICE MAKER PARTS

CAUTION: Use the part number to order part, not the position number.

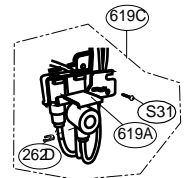
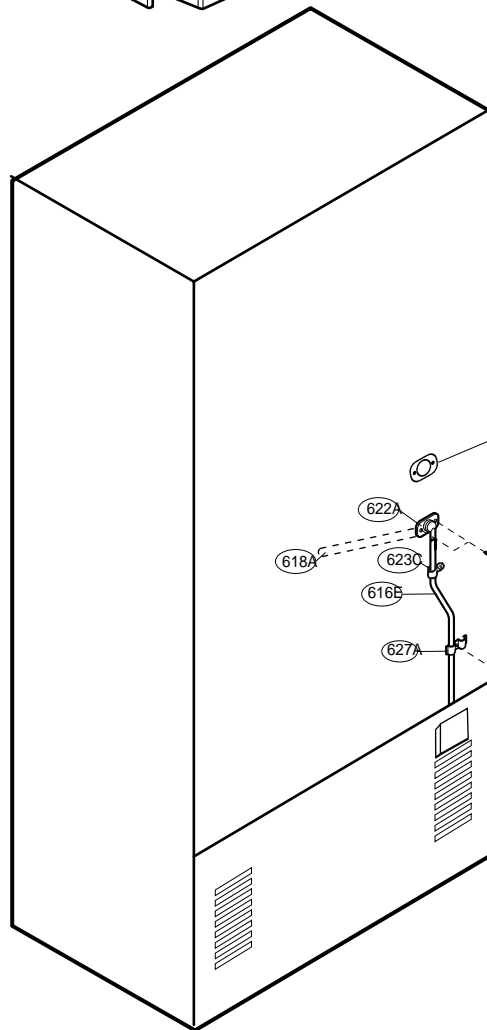
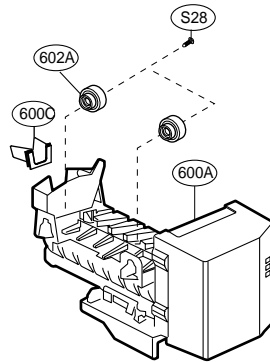
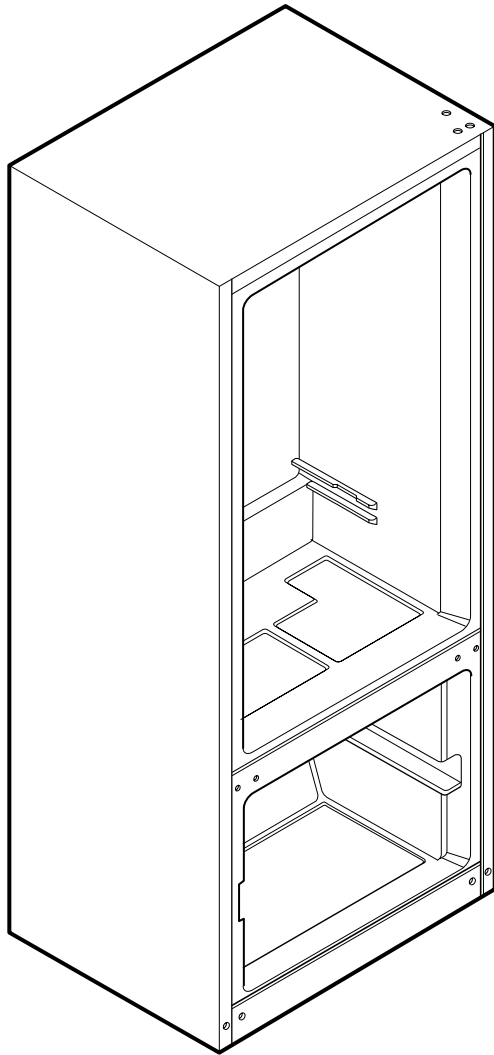

Loc No.	Part No.	Description	Loc No.	Part No.	Description
103A	3650JJ2003M	Handle,Rear	271C	4775JJ2018A	Hinge Assembly,Upper
103B	3650JJ2003L	Handle,Rear	281A	3551JJ1018B	Cover Assembly,Hinge
103C	3551JJ1015E	Cover Assembly,Lower	282B	4775JJ2019C	Hinge Assembly,Center
103E	5218JJ3001A	Rail,Slide	282E	3551JJ1018E	Cover Assembly,Hinge
104E	4931JJ3002A	Holder Assembly,Gasket	282F	3806JL2006F	Decor,Duct
105A	5251JA3003B	Tube Assembly,Drain	286A	4984JJ3003A	BUSH
105F	5070JJ3002A	Skirt,Lower	286A	4984JJ3003A	BUSH
106A	4779JA2003A	Leg Assembly,Adjust	301A	5421JJ1001A	Evaporator Assembly
120B	5209JJ1002A	Duct Assembly,Multi	304A	3551JJ2008A	Cover Assembly,Machinery(Rear)
125D	4930JJ3007A	Holder,Bracket	305B	4580JJ3001A	Roller
128A	4975JJ2002A	Guide Assembly,Rail	305C	4J04238A	Pin,Common
128B	4975JJ2002B	Guide Assembly,Rail	307A	2521CRA5715	Compressor,Set Assembly
128E	4930JJ1025B	Holder,Rail	308A	EBG32606502	Thermistor Assembly,PTC
128F	4930JJ1025A	Holder,Rail	309A	6750C-0004S	Overload Protect
131A	5074JJ1055A	BUCKET,ICE	310A	3550JA2059A	Cover,PTC
135C	3550JJ2030A	Cover,Grille Fan	312A	5040JA3031A	Damper,Compressor
136A	3391JJ1011A	Tray Assembly,Drawer	314A	4620JA3009A	Stopper,Compressor
136B	3390JJ1095A	Tray,Drawer	315A	3103JJ1001K	Base Assembly,Compressor
140B	5027JJ1037B	Shelf Assembly,Refrigerator	317A	5851JJ2002F	Drier Assembly
140D	MHL38615403	Shelf,Net	318A	4930JA3034A	Holder,Drier
140E	MHL38615404	Shelf,Net	319A	3390JJ0003A	Tray,Drip
142D	5026JJ2001L	Shelf,Net	319C	4974JJ1009A	Guide,Fan
142E	5026JJ2001M	Shelf,Net	319E	4810JJ2005A	Bracket,Motor
143E	5027JJ1008L	Shelf Assembly,Refrigerator	323B	5403JJ1008A	Condenser Assembly,Wire
143F	5027JJ1008G	Shelf Assembly,Refrigerator	327A	5006JA3034A	Cap,Drain Tube
145A	4930JJ2003A	Holder,Shelf	328A	4J03020A	Damper,Pipe
145B	4930JJ2004A	Holder,Shelf	328A	4J03020A	Damper,Pipe
145C	4975JJ2028C	Guide Assembly,Rail	329A	5901JJ1005A	Fan Assembly
145F	4975JJ2028D	Guide Assembly,Rail	329C	5901JJ1004B	Fan Assembly
146A	5047JJ1001A	Case,Lower	332A	3531JJ1004B	Grille Assembly,Fan
151A	3390JJ1032A	Tray,Vegetable	401A	6615JB2005C	Controller Assembly
151C	4940JJ2003C	KNOB,SHUTTER	402A	6600JB3007E	Switch,Push Button
154A	3550JL2001L	Cover,TV	402A	6600JB3007E	Switch,Push Button
155B	4980JJ1016A	SUPPORTER,COVER TV	404A	4681JK1004A	AC Motor
158A	3550JJ1040A	Cover,Lamp	405A	4811JJ2002A	Bracket Assembly,Motor
158E	MCK30060901	Cover,Lamp	405C	5040JA2009B	Damper,Motor Support
167B	4890JL1002G	Shelf,Glass	405F	5040JA2004B	Damper,Motor Support
170A	3391JJ2004G	Tray Assembly,Meat	405G	4811JJ2002H	Bracket Assembly,Motor
200A	3581JJ8720N	Door Assembly,Freezer	406B	6600JB1010A	Switch,Push Button
201A	5433JJ0059V	Door Foam Assembly,Freezer	409B	6912JB2004M	Lamp,Incandescent
203A	4987JJ1004G	Gasket Assembly,Door	409D	3034JJ1002B	Reflector,Lamp
205B	5006JJ2014A	CAP,COVER	410A	6621JK2002D	Drawing,Assembly
205C	5006JJ2014B	CAP,COVER	410G	0CZZJB2012J	Capacitor,Electric Appliance Film,Box
212A	3651JA1033J	Handle Assembly,Freezer	411A	6411JK1006A	Power Cord Assembly
212G	3846JD1007H	Name Plate	418A	5300JB1100D	Heater,Sheath
212J	4620JJ3007E	Stopper,Handle	420A	4680JK1001B	Motor,AC
230A	ADC33235304	Door Assembly,Refrigerator(Right)	501A	EBR36222901	PCB Assembly,Main
230B	ADC33235204	Door Assembly,Refrigerator(Left)	501F	3551JJ1020A	Cover Assembly,PCB
231A	ADD32184804	Door Foam Assembly,Refrigerator	503C	6871JB2047A	PCB Assembly,Display
231B	ADD32184904	Door Foam Assembly,Refrigerator	503D	3110JJ1005A	Case,Display
233A	4987JJ2003K	Gasket Assembly,Door	503E	3550JJ2031A	Cover,Display
233B	4987JJ2003M	Gasket Assembly,Door	503F	ABQ33905312	Case Assembly,Display
233C	3551JJ2034D	Cover Assembly,Front	503G	3806JL1049A	Decor,Control
233D	3551JJ2034C	Cover Assembly,Front	600A	5989JA0002N	Ice Maker Assembly,Kit
233E	4930JJ2028F	Holder,Gasket	600C	MEA32865501	Guide,Tube
233F	4930JJ2028E	Holder,Gasket	602A	4931JA3005B	Holder Assembly,Bracket
233G	4430JJ2005B	Cam,Shaft	610A	3550JJ2020A	Cover,Sensor
233H	4430JJ2005A	Cam,Shaft	616E	5210JA3005N	Tube,Plastic
237A	4974JJ2017A	Guide,Pitcher	618A	5210JJ3005B	Tube,Inject
237C	4974JJ1021A	Guide,Drawer	619A	5220JA2009D	Valve,Water
241A	3550JL2006D	Cover,Tray	619B	3550JJ2024A	Cover,Valve
241B	MKK33992902	Bucket,Dairy	619C	5221JA2008G	Valve Assembly,Water
241C	5005JJ2022B	Basket Assembly,Door	621B	ACJ30147004	Connector Assembly
241F	5005JJ2021F	Basket Assembly,Door	621C	ACJ30147003	Connector Assembly
243A	4620JJ3006C	Stopper,Door	622A	5040JA2015A	Tube,Inlet
243B	4620JJ2009A	Stopper,Door	622B	4810JA3036A	Bracket,Cover
244A	3651JA1023U	Handle Assembly,Freezer	623C	4770JA3001A	Band
248E	3806JJ1051A	Decor,Tray	627A	4930JA3054A	Holder,Pipe
248F	3806JL2011A	Decor,Tray	903A	3550JJ0005C	Cover,Lower
249A	5098JJ1002B	Connector Assembly	903B	4930JJ2021A	Holder,Cover(Lower)
249B	5098JJ1002A	Connector Assembly	903D	6500JK1003A	Sensor
249E	5218JA1010E	Rail,Slide	903E	6500JK1004A	Sensor
249F	5218JA1010F	Rail,Slide	S01	1SZZJJ3010A	Screw,Customized
249J	3550JJ1111A	Cover,Connector	S22	J471-00001J	Screw,Customized
249K	3550JJ1111B	Cover,Connector	S24	1SZZJA3011B	Screw,Customized
250A	4270JJ3001F	Bar	S27	4J01424C	Screw,Customized
250B	4403JJ3001A	Connector Assembly	S28	1SZZJJ3005E	Screw,Customized
262D	4004JA3002A	Clip	S29	4J00415D	Screw,Customized
262E	4350JA3005B	Ring	S31	4000W4A003A	Screw,Customized
262H	4775JJ2019D	Hinge Assembly,Center	S38	4J00415D	Screw,Customized
271A	4775JJ2018B	Hinge Assembly,Upper			

Loc No.	Part No.	Description	Loc No.	Part No.	Description
103A	3650JJ2003E	Handle,Rear	271A	4775JJ2018B	Hinge Assembly,Upper
103B	3650JJ2003A	Handle,Rear	271C	4775JJ2018A	Hinge Assembly,Upper
103C	3551JJ1015A	Cover Assembly,Lower	281A	3551JJ1018A	Cover Assembly,Hinge
103E	5218JJ3001A	Rail,Slide	282B	4775JJ2019A	Hinge Assembly,Center
104E	4931JJ3002A	Holder Assembly,Gasket	282E	3551JJ1018D	Cover Assembly,Hinge
105A	5251JA3003B	Tube Assembly,Drain	282F	3806JL2006F	Decor,Duct
105F	5070JJ3002A	Skirt,Lower	286A	4984JJ3003A	BUSH
106A	4779JA2003A	Leg Assembly,Adjust	286A	4984JJ3003A	BUSH
120B	5209JJ1002A	Duct Assembly,Multi	301A	5421JJ1001A	Evaporator Assembly
125D	4930JJ3007A	Holder,Bracket	304A	3551JJ2008A	Cover Assembly,Machinery(Rear)
128A	4975JJ2002A	Guide Assembly,Rail	305B	4580JJ3001A	Roller
128B	4975JJ2002B	Guide Assembly,Rail	305C	4J04238A	Pin,Common
128E	4930JJ1025B	Holder,Rail	307A	2521CRA5715	Compressor,Set Assembly
128F	4930JJ1025A	Holder,Rail	308A	EBG32606502	Thermistor Assembly,PTC
131A	5074JJ1055A	BUCKET,ICE	309A	6750C-0004S	Overload Protect
135C	3550JJ2030A	Cover,Grille Fan	310A	3550JA2059A	Cover,PTC
136A	3391JJ1011A	Tray Assembly,Drawer	312A	5040JA3031A	Damper,Compressor
136B	3390JJ1095A	Tray,Drawer	314A	4620JA3009A	Stopper,Compressor
140B	5027JJ1037B	Shelf Assembly,Refrigerator	315A	3103JJ1001K	Base Assembly,Compressor
140D	MHL38615403	Shelf,Net	317A	5851JJ2002F	Drier Assembly
140E	MHL38615404	Shelf,Net	318A	4930JA3034A	Holder,Drier
142D	5026JJ2001L	Shelf,Net	319A	3390JJ0003A	Tray,Drip
142E	5026JJ2001M	Shelf,Net	319C	4974JJ1009A	Guide,Fan
143E	5027JJ1008L	Shelf Assembly,Refrigerator	319E	4810JJ2005A	Bracket,Motor
143F	5027JJ1008G	Shelf Assembly,Refrigerator	323B	5403JJ1008A	Condenser Assembly,Wire
145A	4930JJ2003A	Holder,Shelf	327A	5006JA3034A	Cap,Drain Tube
145B	4930JJ2004A	Holder,Shelf	328A	4J03020A	Damper,Pipe
145C	4975JJ2028C	Guide Assembly,Rail	329A	5901JJ1005A	Fan Assembly
145F	4975JJ2028D	Guide Assembly,Rail	329C	5901JJ1004B	Fan Assembly
146A	5047JJ1001A	Case,Lower	332A	3531JJ1004B	Grille Assembly,Fan
151A	3390JJ1032A	Tray,Vegetable	401A	6615JB2005C	Controller Assembly
151C	4940JJ2003C	KNOB,SHUTTER	402A	6600JB3007A	Switch,Push Button
154A	3550JL2001L	Cover,TV	404A	4681JK1004A	AC Motor
155B	4980JJ1016A	SUPPORTER,COVER TV	405A	4811JJ2002A	Bracket Assembly,Motor
158A	3550JJ1040A	Cover,Lamp	405C	5040JA2009B	Damper,Motor Support
158E	MCK30060901	Cover,Lamp	405F	5040JA2004B	Damper,Motor Support
167B	4890JL1002G	Shelf,Glass	405G	4811JJ2002H	Bracket Assembly,Motor
170A	3391JJ2004G	Tray Assembly,Meat	406B	6600JB1010A	Switch,Push Button
200A	3581JJ8720K	Door Assembly,Freezer	409B	6912JB2004M	Lamp,Incandescent
201A	5433JJ0059S	Door Foam Assembly,Freezer	409D	3034JJ1002B	Reflector,Lamp
203A	4987JJ1004C	Gasket Assembly,Door	410A	6621JK2002D	Drawing,Assembly
205B	5006JJ2014A	CAP,COVER	410G	0CZZJB2012J	Capacitor,Electric Appliance Film,Box
205C	5006JJ2014B	CAP,COVER	411A	6411JK1006A	Power Cord Assembly
212A	3651JA1033K	Handle Assembly,Freezer	418A	5300JB1100D	Heater,Sheath
212G	3846JD1007F	Name Plate	420A	4680JK1001B	Motor,AC
212J	4620JJ3007E	Stopper,Handle	501A	EBR36222901	PCB Assembly,Main
230A	ADC33235301	Door Assembly,Refrigerator(Right)	501F	3551JJ1020A	Cover Assembly,PCB
230B	ADC33235201	Door Assembly,Refrigerator(Left)	503C	6871JB2047A	PCB Assembly,Display
231A	ADD32184801	Door Foam Assembly,Refrigerator	503D	3110JJ1005A	Case,Display
231B	ADD32184901	Door Foam Assembly,Refrigerator	503E	3550JJ2031A	Cover,Display
233A	4987JJ2003J	Gasket Assembly,Door	503F	ABQ33905312	Case Assembly,Display
233B	4987JJ2003L	Gasket Assembly,Door	503G	3806JL1049A	Decor,Control
233C	3551JJ2034D	Cover Assembly,Front	600A	5989JA0002N	Ice Maker Assembly,Kit
233D	3551JJ2034C	Cover Assembly,Front	600C	MEA32865501	Guide,Tube
233E	4930JJ2028F	Holder,Gasket	602A	4931JA3005B	Holder Assembly,Bracket
233F	4930JJ2028E	Holder,Gasket	610A	3550JJ2020A	Cover,Sensor
233G	4430JJ2005B	Cam,Shaft	616E	5210JA3005N	Tube,Plastic
233H	4430JJ2005A	Cam,Shaft	618A	5210JJ3005B	Tube,Inject
237A	4974JJ2017A	Guide,Pitcher	619A	5220JA2009D	Valve,Water
237C	4974JJ1021A	Guide,Drawer	619B	3550JJ2024A	Cover,Valve
241A	3550JL2006D	Cover,Tray	619C	5221JA2008G	Valve Assembly,Water
241B	MKK33992902	Bucket,Dairy	621B	ACJ30147004	Connector Assembly
241C	5005JJ2022B	Basket Assembly,Door	621C	ACJ30147003	Connector Assembly
241F	5005JJ2021F	Basket Assembly,Door	622A	5040JA2015A	Tube,Inlet
243A	4620JJ3006A	Stopper,Door	622B	4810JA3036A	Bracket,Cover
243B	4620JJ2009A	Stopper,Door	623C	4770JA3001A	Band
244A	3651JA1023X	Handle Assembly,Freezer	627A	4930JA3054A	Holder,Pipe
248E	3806JJ1051A	Decor,Tray	903A	3550JJ0005A	Cover,Lower
248F	3806JL2011A	Decor,Tray	903B	4930JJ2021A	Holder,Cover(Lower)
249A	5098JJ1002B	Connector Assembly	903D	6500JK1003A	Sensor
249B	5098JJ1002A	Connector Assembly	903E	6500JK1004A	Sensor
249E	5218JA1010E	Rail,Slide	S01	1SZZJJ3010A	Screw,Customized
249F	5218JA1010F	Rail,Slide	S22	J471-00001J	Screw,Customized
249J	3550JJ1111A	Cover,Connector	S24	1SZZJA3011B	Cover,Customized
249K	3550JJ1111B	Cover,Connector	S27	4J01424C	Screw,Customized
250A	4270JJ3001F	Bar	S28	1SZZJJ3005E	Screw,Customized
250B	4403JJ3001A	Connector Assembly	S29	4J00415D	Screw,Customized
262D	4004JA3002A	Clip	S31	4000W4A003A	Screw,Customized
262E	4350JA3005B	Ring	S38	4J00415D	Screw,Customized
262H	4775JJ2019B	Hinge Assembly,Center			



P/No. 3828JL8076G

JUNE, 2007