



**LG**

# REFRIGERATOR

# SERVICE MANUAL

**CAUTION**  
BEFORE SERVICING THE PRODUCT,  
READ THE SAFETY PRECAUTIONS IN THIS MANUAL.

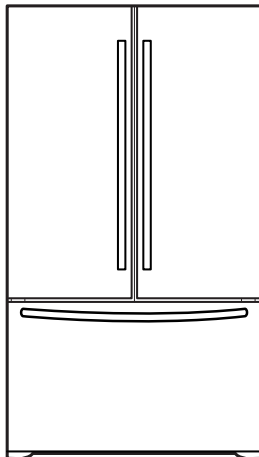

**MODELS:** LFC21760ST    LFC25760SW  
          LFC25760SB    LFC25760TT  
          LFC25760ST

**COLORS:** WESTERN BLACK(SB)  
          TITANIUM(TT)  
          SUPER WHITE(SW)  
          STAINLESS(ST)

# CONTENTS

---

<b>SAFETY PRECAUTIONS</b> .....	<b>2</b>
<b>SPECIFICATIONS</b> .....	<b>3</b>
<b>PARTS IDENTIFICATION</b> .....	<b>4</b>
<b>DISASSEMBLY</b> .....	<b>5-10</b>
DOOR.....	5-6
DOOR ALIGNMENT .....	6
HOW TO REMOVE AND REINSTALL THE PULLOUT DRAWER.....	7-9
<b>ADJUSTMENT</b> .....	<b>10-11</b>
COMPRESSOR.....	10
PTC-STARTER.....	10
OLP (OVERLOAD PROTECTOR).....	11
TO REMOVE THE COVER PTC .....	11
<b>CIRCUIT DIAGRAM</b> .....	<b>12</b>
<b>TROUBLESHOOTING</b> .....	<b>13-18</b>
COMPRESSOR AND ELECTRIC COMPONENTS .....	13
PTC AND OLP .....	14
OTHER ELECTRICAL COMPONENTS .....	15
SERVICE DIAGNOSIS CHART.....	16
REFRIGERATION CYCLE .....	17-18
<b>OPERATION PRINCIPLE AND REPAIR METHOD OF ICEMAKER</b> .....	<b>19-22</b>
<b>DESCRIPTION OF FUNCTION AND CIRCUIT OF MICOM</b> .....	<b>23-40</b>
<b>EXPLODED VIEW AND REPLACEMENT PARTS LIST</b> .....	<b>41-</b>

# SAFETY PRECAUTIONS

---

Please read the following instructions before servicing your refrigerator.

1. Unplug the power before handling any electrical components.
2. Check the rated current, voltage, and capacity.
3. Take caution not to get water near any electrical components.
4. Use exact replacement parts.
5. Remove any objects from the top prior to tilting the product.

# 1. SPECIFICATIONS

ITEMS	SPECIFICATIONS	ITEMS	SPECIFICATIONS	
DOOR DESIGN	Side Rounded	VEGETABLE TRAY	Opaque Drawer Type	
COOLING SYSTEM	Fan Cooling	COMPRESSOR	PTC Starting Type	
TEMPERATURE CONTROL	Micom Control	EVAPORATOR	Fin Tube Type	
DEFROSTING SYSTEM	Full Automatic	CONDENSER	Wire Condenser	
	Heater Defrost	REFRIGERANT	R-134a (115 g)	
DOOR FINISH	PCM, VCM, Stainless	LUBRICATING OIL	ISO10 (280 ml)	
HANDLE TYPE	Bar	DEFROSTING DEVICE	SHEATH HEATER	
INNER CASE	ABS Resin	LAMP	REFRIGERATOR	60 W (2 EA)
INSULATION	Polyurethane Foam		FREEZER	60 W (1 EA)

## DIMENSIONS

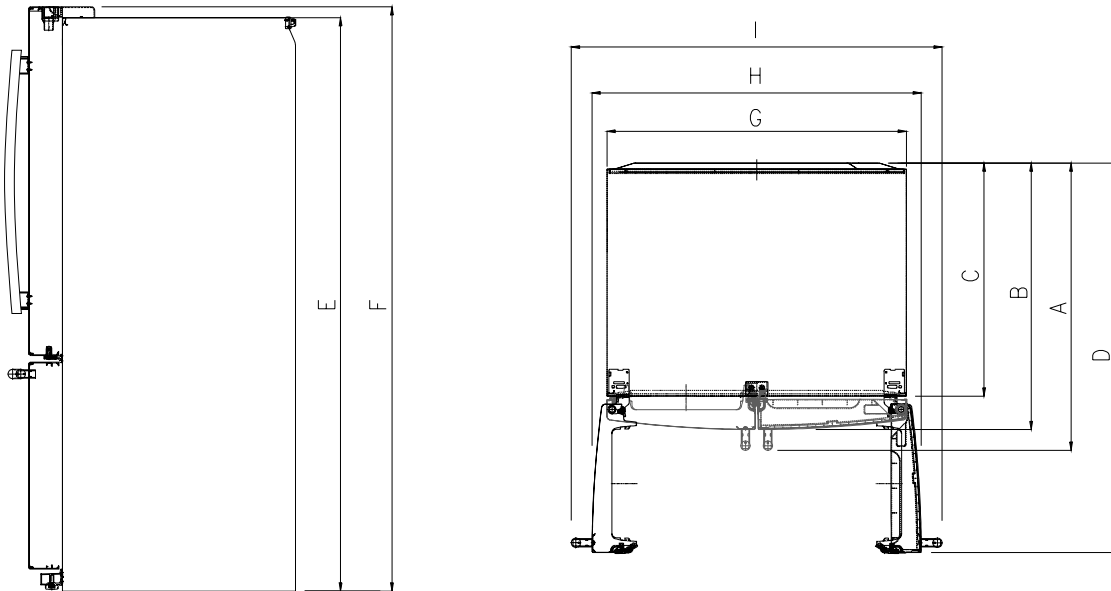

Description		LFC21760**	LFC25760**
Depth w/ Handles	A	30 in.	34 1/4 in.
Depth w/o Handles	B	27 1/2 in.	31 3/4 in.
Depth w/o Door	C	23 5/8 in.	27 7/8 in.
Depth (Total with Door Open)	D	42 1/4 in.	46 1/2 in.
Height to Top of Case	E	68 3/8 in.	68 3/8 in.
Height to Top of Door Hinge	F	69 3/4 in.	69 3/4 in.
Width	G	35 3/4 in.	35 3/4 in.
Width (door open 90 deg. w/o handle)	H	39 1/4 in.	39 1/4 in.
Width (door open 90 deg. w/ handle)	I	44 1/4 in.	44 1/4 in.

# 2. PARTS IDENTIFICATION

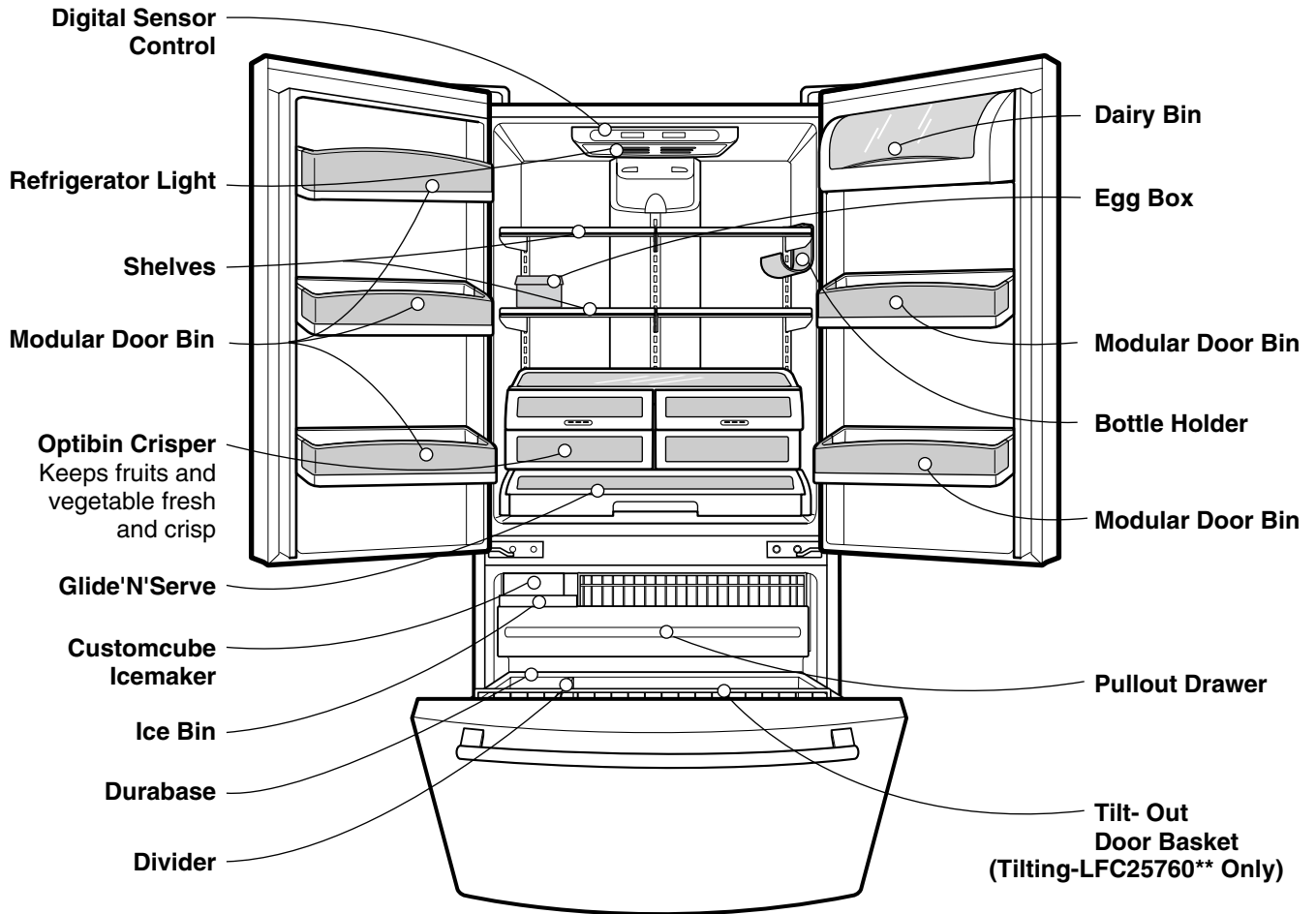

# 3. DISASSEMBLY

## 3-1 DOOR

### ● Refrigerator door

1. Remove the top hinge cover and disconnect the wire harness.
2. Remove the ground screw.
3. Rotate the lever hinge and lift off hinge.
4. Lift off the refrigerator door.
5. Replace in the reverse order.

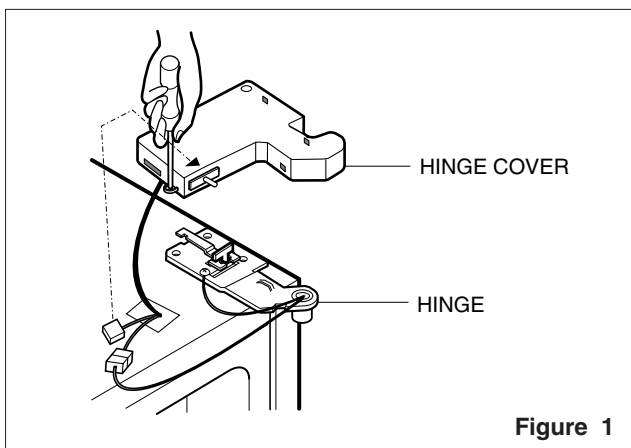

### ● Door gasket removal

#### 1. Remove door frame cover

Starting at top of cover and working down, snap cover out and away from door.

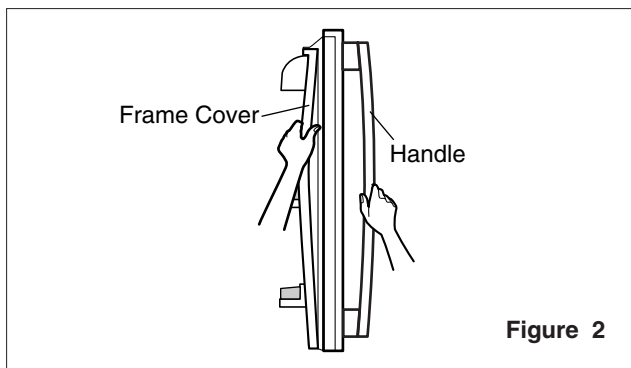

#### 2. Remove gasket bracket clips

There are two clips on each door. Start bracket removal near one of the middle clips.

- 1) Pull gasket back to expose gasket bracket clip and door frame.
- 2) Insert a flat tip screwdriver into seam between gasket bracket and door frame and pry back until clips snap out.
- 3) Continue prying back along seam until all clips snap out.

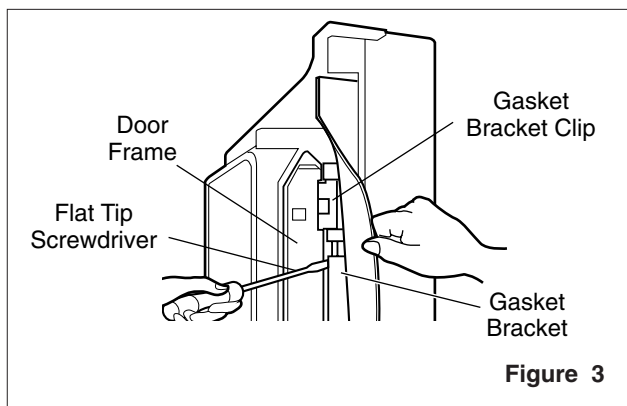

#### 3. Remove gasket

Pull gasket free from gasket channel on the three remaining sides of door.

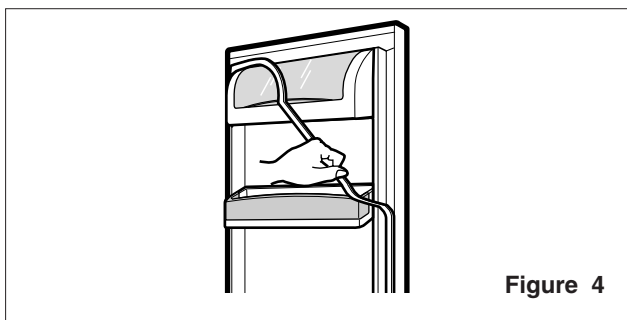

### ● Door gasket replacement

#### 1. Insert gasket bracket clips

- 1) Insert gasket bracket edge beneath door frame edge.
- 2) Turn upper gasket bracket spring so that both spring ends are in the door channel.
- 3) Push in clip until you hear it snap securely into place.

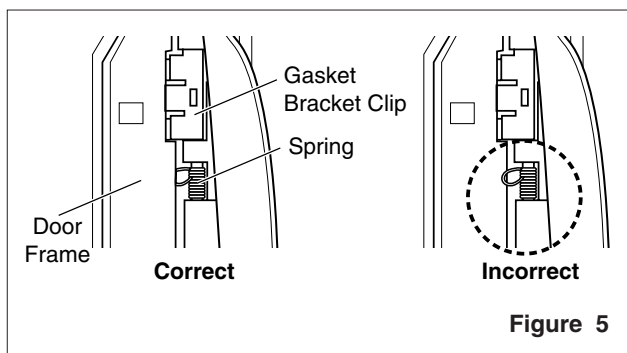

- 4) Push in remaining two clips until you hear each snap securely into place.

**Note:** Make sure that no part of gasket bracket edge protrudes from beneath door frame edge.

## 2. Insert gasket into channel

1) Snap gasket assembly into the door bracket.

**Inserting the gasket assembly into the bracket door**

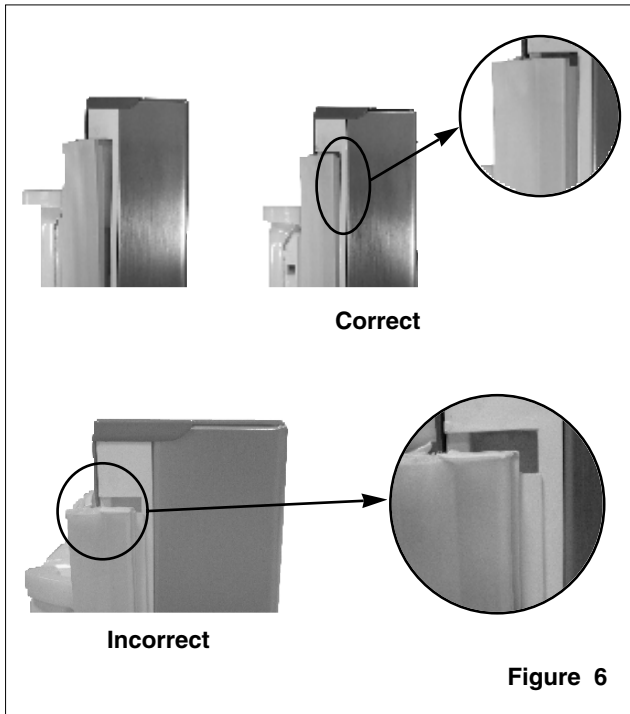

2) Press gasket into channels on the three remaining sides of door.

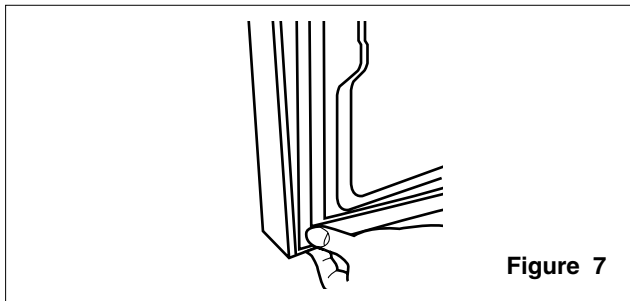

## 3. Replace door frame cover

Starting at top of cover and working down, snap the cover back into door.

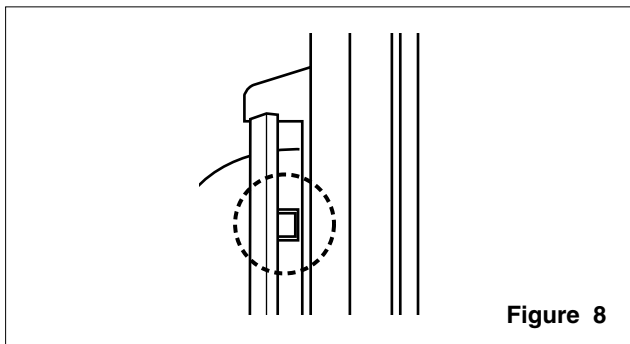

## 3-2 DOOR ALIGNMENT

If the space between your doors is uneven, follow the instructions below to align the doors:

1. With one hand, lift the door you want to raise at middle hinge.
2. With other hand, use pliers to insert snap ring as shown.
3. Insert additional snap rings until the doors are aligned. (Three snap rings are provided with the product.)

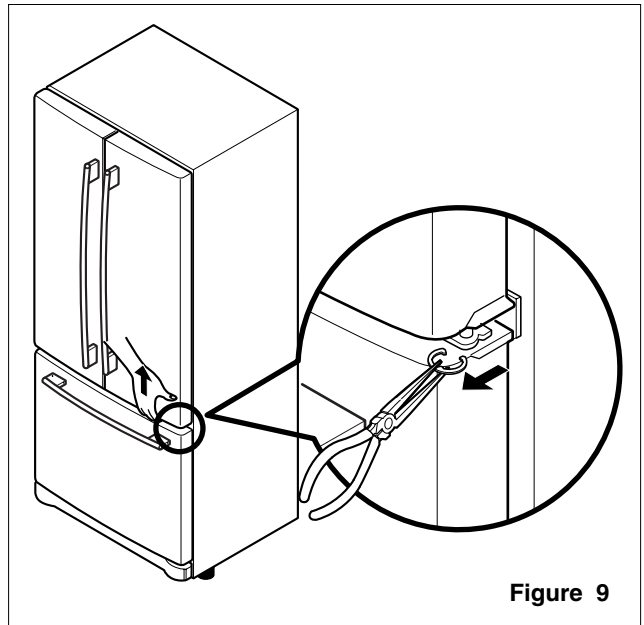

---

### 3-3 HOW TO REMOVE AND REINSTALL THE PULLOUT DRAWER

#### 3-3-1 FOLLOW STEPS TO REMOVE

Step 1) Open the freezer door.



Step 2) Remove the lower basket.



Step 3) Remove the two screws from the guide rails (one from each side).



Step 4) Lift the freezer door up to unhook it from the rail support and remove. Pull both rails to full extension.



Step 5) First: Remove the gear from the left side first by releasing the tab behind the gear, place a screwdriver between the gear and the tab and pull up on the gear.

Second: Remove the center rail.

Third: Remove the gear from the right side by following the same steps for the left side.

**NOTE: THIS TAB MUST BE PUSHED IN TO RELEASE THE GEAR.**

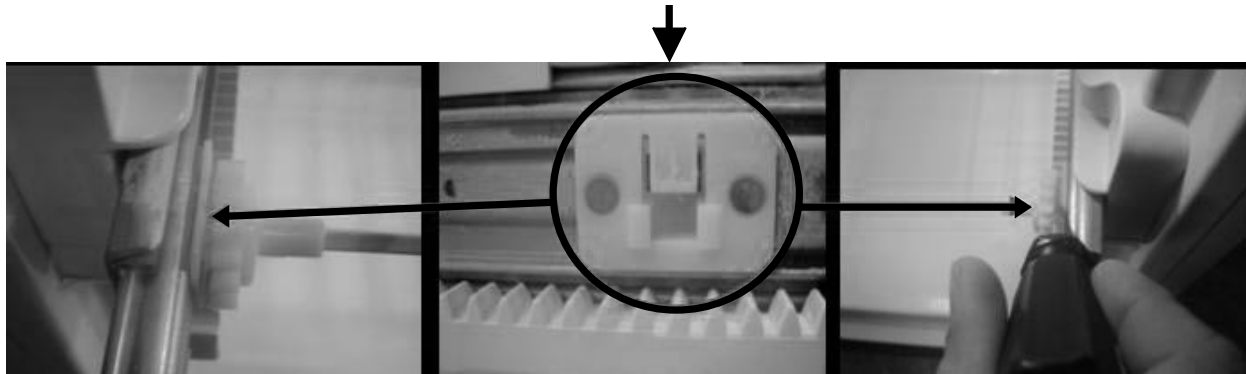

---

### 3-3-2 FOLLOW STEPS TO REINSTALL

Step 1) Reinstall the right side gear into the clip.



Step 2) Insert the rail into the right side gear. Gears do **not** need to be perpendicular to each other.



Step 3) Insert the rail into the left side gear, and insert the gear into the clip.



Step 4) The rail system will align itself by pushing the rails all the way into the freezer section. Pull the rails back out to full extension.



Step 5) Reinstall the freezer door by inserting the rail tabs into the guide rail.

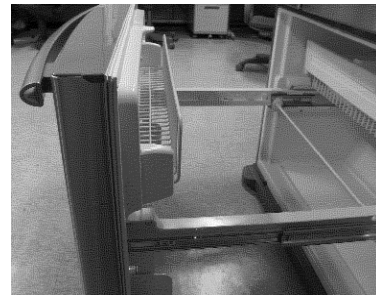

Step 6) Reinstall the two screws into the guide rails (one from each side).

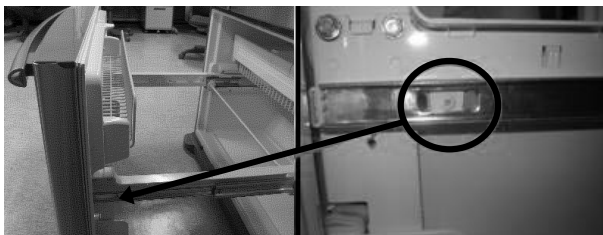

Step 7) Reinstall the lower basket, and close the freezer door.





---

### 3-3-3 PULL OUT DRAWER

To separate the drawer, push the front left and right hooks in ① direction to pull up and remove. Then gently lift the gear part of rear left and right side of the drawer and pull it out in ③ direction.

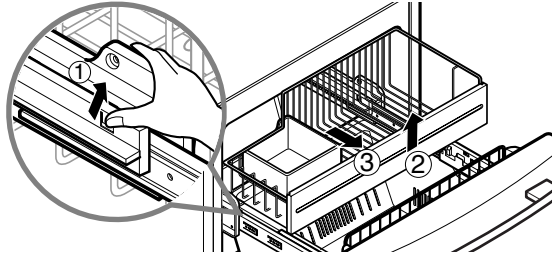

To install, reposition the gear part of rear left and right side of the drawer after pulling out both rails as much as possible, and gently push down both left and right side while checking the hook on the front part.

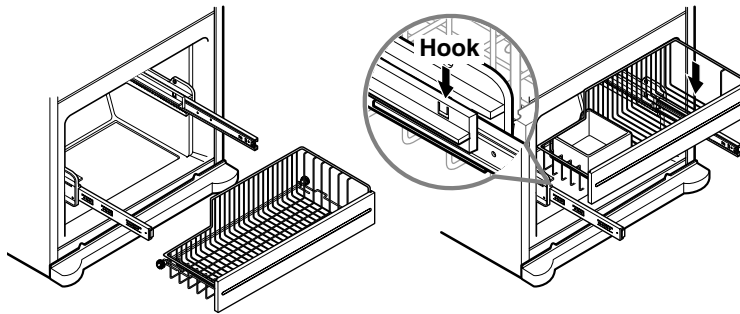

# 4. ADJUSTMENT

## 4-1 COMPRESSOR

### 4-1-1 Role

The compressor intakes low temperature and low pressure gas from the evaporator of the refrigerator and compresses this gas to high-temperature and high-pressure gas. It then delivers the gas to the condenser.

### 4-1-2 Composition

The compressor includes overload protection. The PTC starter and OLP (overload protector) are attached to the outside of the compressor. Since the compressor is manufactured to tolerances of 1 micron and is hermetically sealed in a dust and moisture-free environment, use extreme caution when repairing it.

### 4-1-3 Note for usage

- (1) Be careful not to allow over-voltage and over-current.
- (2) If compressor is dropped or handled carelessly, poor operation and noise may result.
- (3) Use proper electric components appropriate to the particular compressor in your product.
- (4) Keep compressor dry.  
If the compressor gets wet (in the rain or a damp environment) and rust forms in the pin of the Hermetic Terminal, poor operation and contact may result. If the hermetic connector rusts out or fails, refrigerant and oil will be expelled into the contact area, probably resulting in smoke and fire.
- (5) When replacing the compressor, be careful that dust, humidity, and soldering flux don't contaminate the inside of the compressor. Contamination in the cylinder may cause noise, improper operation or even cause it to lock up.

## 4-2 PTC-STARTER

### 4-2-1 Composition of PTC-Starter

- (1) PTC (Positive Temperature Coefficient) is a no-contact semiconductor starting device which uses ceramic material consisting of BaTiO<sub>3</sub>.
- (2) The higher the temperature is, the higher the resistance value. These features are used as a starting device for the motor.

### 4-2-2 Role of PTC-Starter

- (1) The PTC is attached to the sealed compressor and is used for starting the motor.
- (2) The compressor is a single-phase induction motor. During the starting operation, the PTC allows current flow to both the start winding and main winding.

### 4-2-3 PTC-Applied circuit diagram

#### ● Starting method for the motor

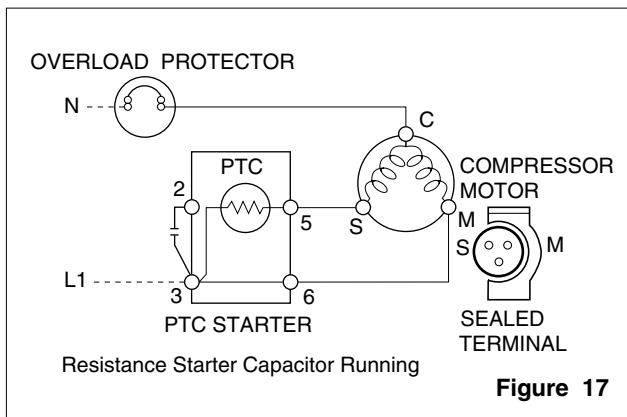

### 4-2-4 Motor restarting and PTC cooling

- (1) It requires approximately 5 minutes for the pressure to equalize before the compressor can restart.
- (2) The PTC device generates heat during operation. Therefore, it must be allowed to cool before the compressor can restart.

### 4-2-5 Relation of PTC-Starter and OLP

- (1) If the compressor attempts to restart before the PTC device is cooled, the PTC device will allow current to flow only to the main winding.
- (2) The OLP will open because of the overcurrent condition. This same process will continue (3 to 5 times) when the compressor attempts to restart until the PTC device has cooled. The correct OLP must be properly attached to prevent damage to the compressor.

**Parts may appear physically identical but could have different electrical ratings. Replace parts by part number and model number. Using an incorrect part could result in damage to the product, fire, injury, or possibly death.**

### 4-2-6 Note for using the PTC-Starter

- (1) Be careful not to allow over-voltage and over-current.
- (2) Do not drop or handle carelessly.
- (3) Keep away from any liquid.  
If liquid such as oil or water enters the PTC, PTC materials may fail due to breakdown of their insulating capabilities.
- (4) If the exterior of the PTC is damaged, the resistance value may be altered. This can cause damage to the compressor and result in a no-start or hard-to-start condition.
- (5) Always use the PTC designed for the compressor and make sure it is properly attached to the compressor. Parts may appear physically identical but could have different electrical ratings. Replace parts by part number and model number. Using an incorrect part could result in damage to the product, fire, injury, or possibly death.

### 4-3 OLP (OVERLOAD PROTECTOR)

#### 4-3-1 Definition of OLP

- (1) OLP (OVERLOAD PROTECTOR) is attached to the compressor and protects the motor by opening the circuit to the motor if the temperature rises and activating the bimetal spring in the OLP.
- (2) When high current flows to the compressor motor, the bimetal works by heating the heater inside the OLP, and the OLP protects the motor by cutting off the current flowing to the compressor motor.

#### 4-3-2 Role of the OLP

- (1) The OLP is attached to the sealed compressor used for the refrigerator. It prevents the motor coil from being started in the compressor.
- (2) For normal operation of the OLP, do not turn the adjustment screw of the OLP in any way.

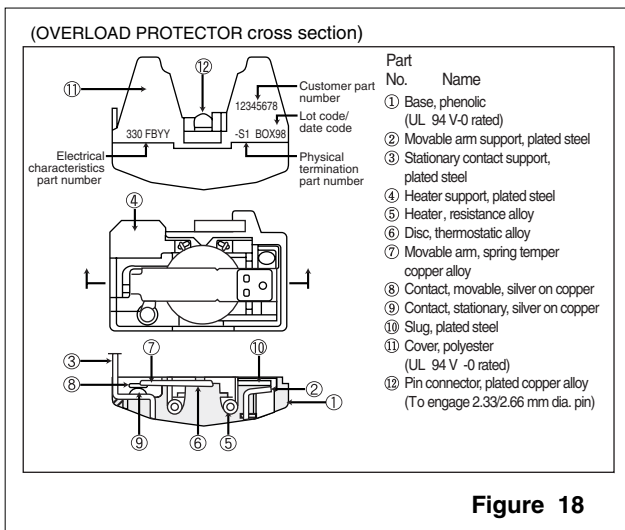
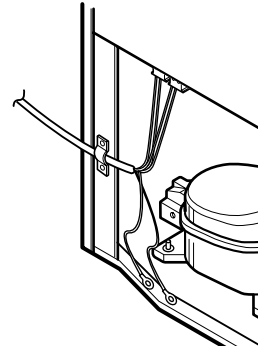
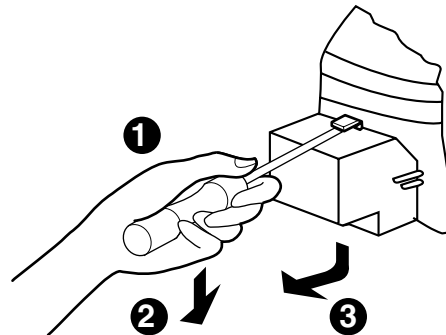

Figure 18

### 4-4 TO REMOVE THE COVER PTC



- (1) Remove the back cover of the mechanical area..
- (2) Disconnect the two connectors on the top of the compressor..
- (3) Loosen two screws on compressor base.



- (4) Use a flat screwdriver to pry off the cover.
- (5) Assembly is the reverse order of disassembly.

# 5. CIRCUIT DIAGRAM

BETTER MODEL

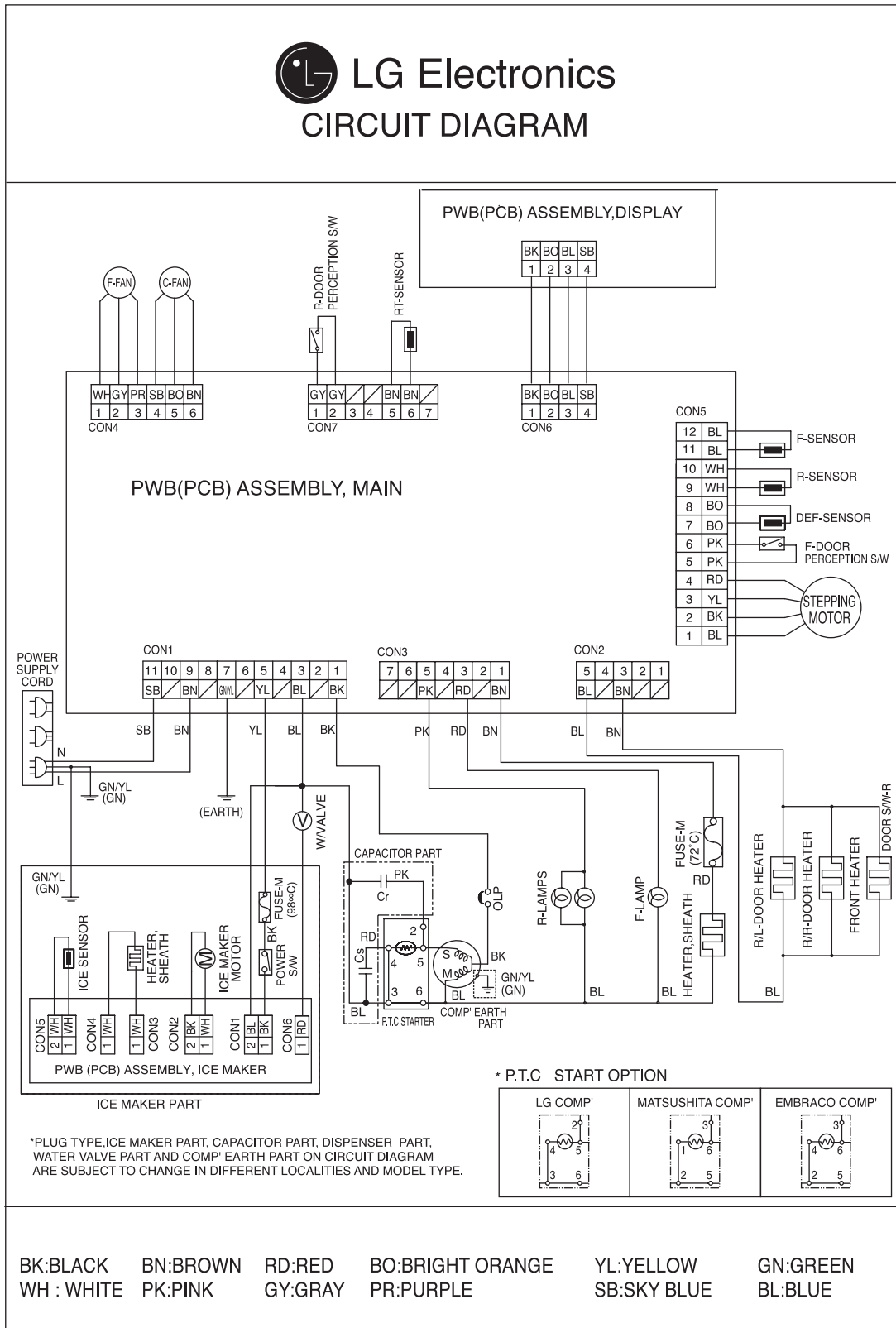

# 6. TROUBLESHOOTING

## 6-1 COMPRESSOR AND ELECTRIC COMPONENTS

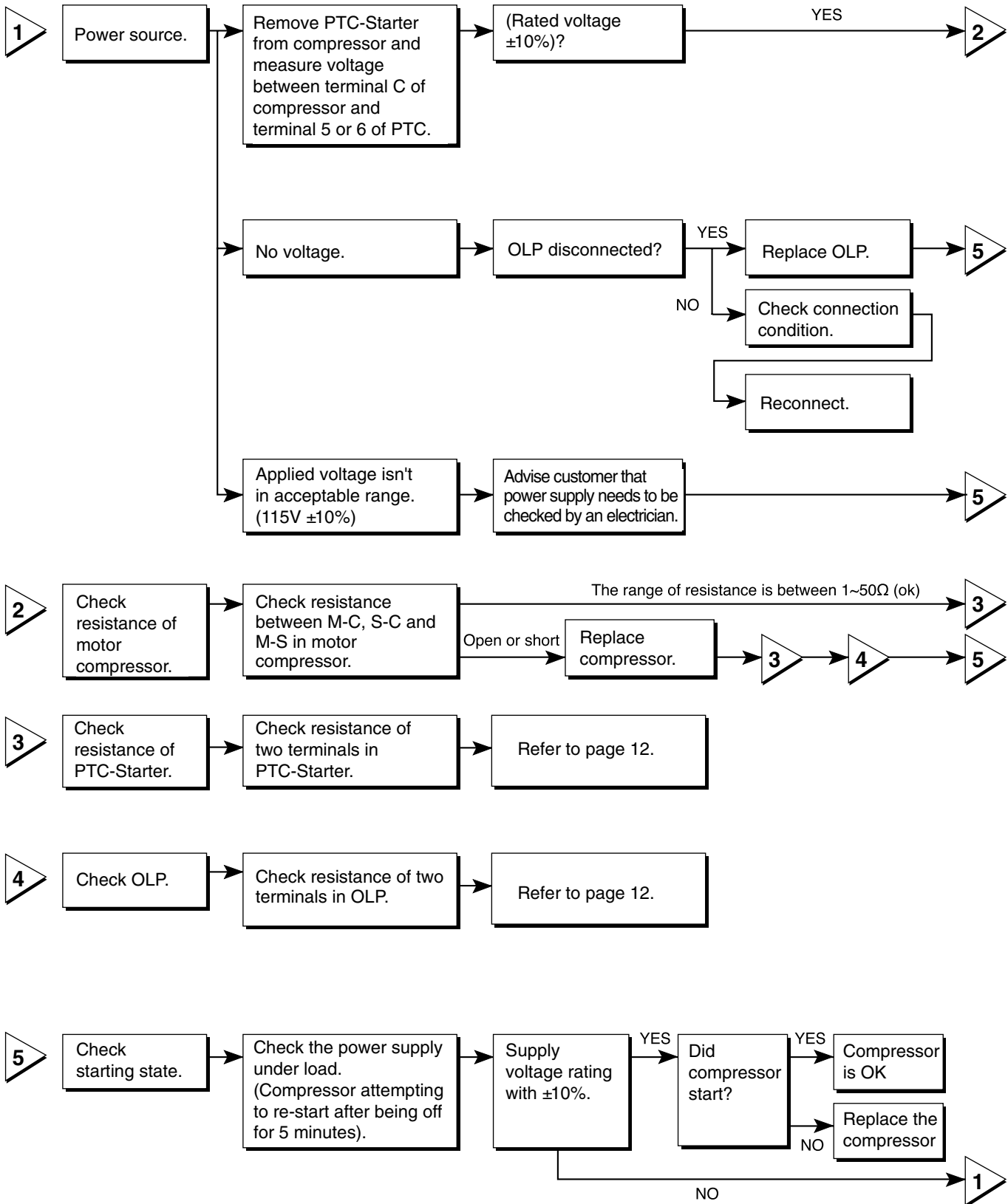

## 6-2 PTC AND OLP

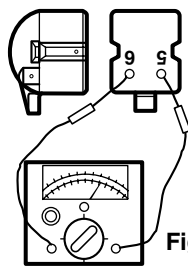
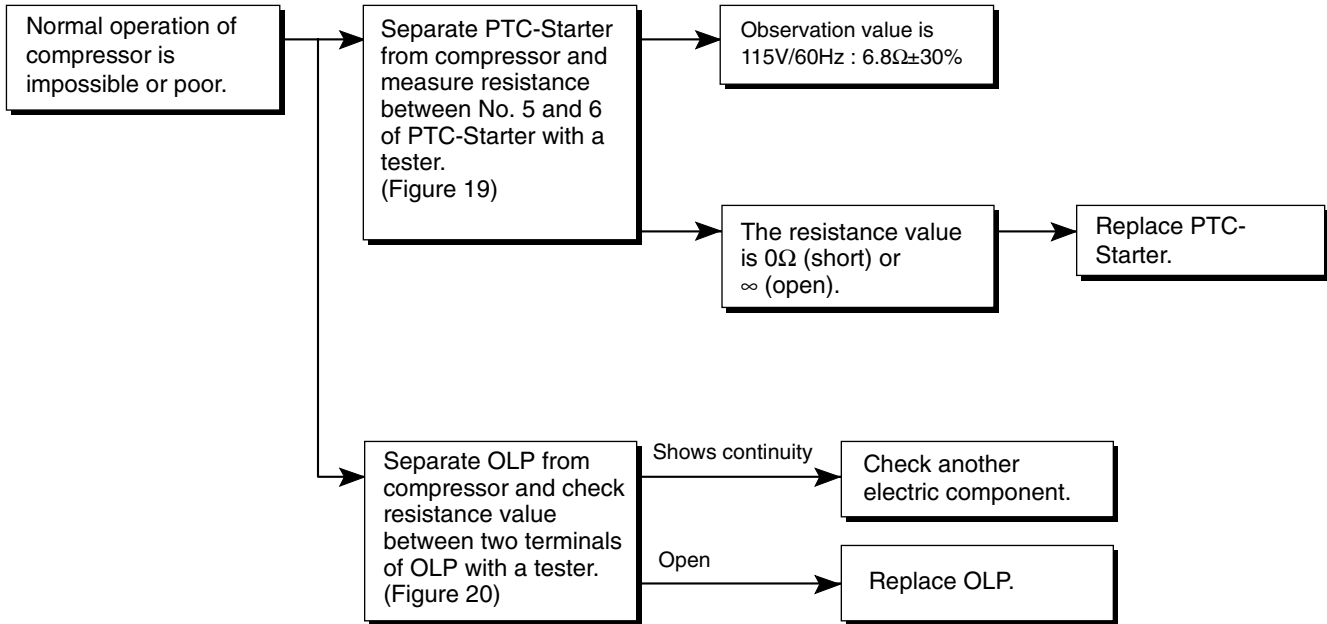

Figure 19

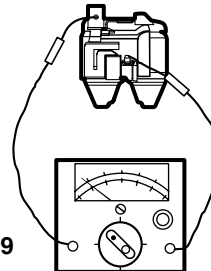
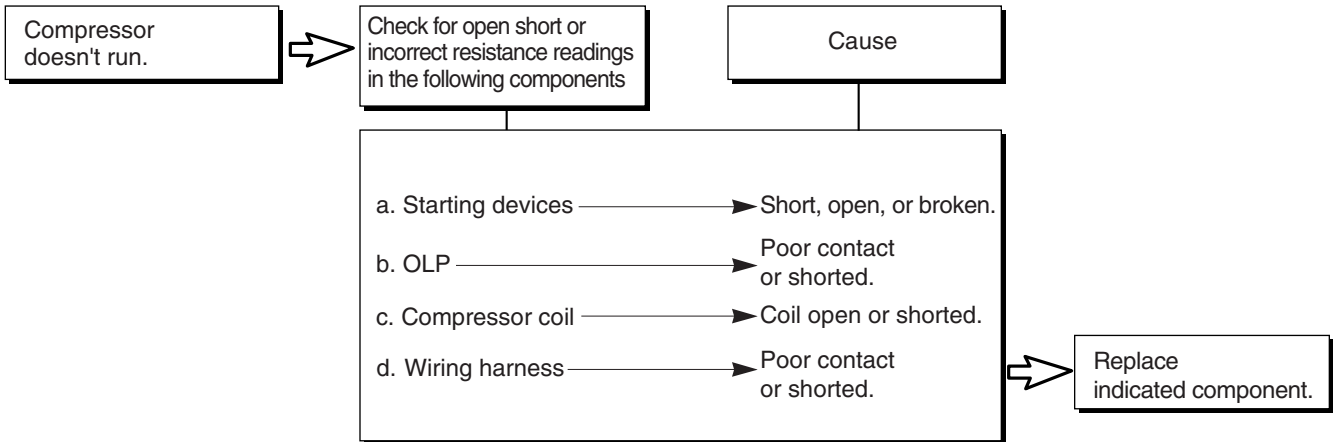

Figure 20

### 6-3 OTHER ELECTRICAL COMPONENTS

#### ▼ Not cooling at all



#### ▼ Poor cooling performance

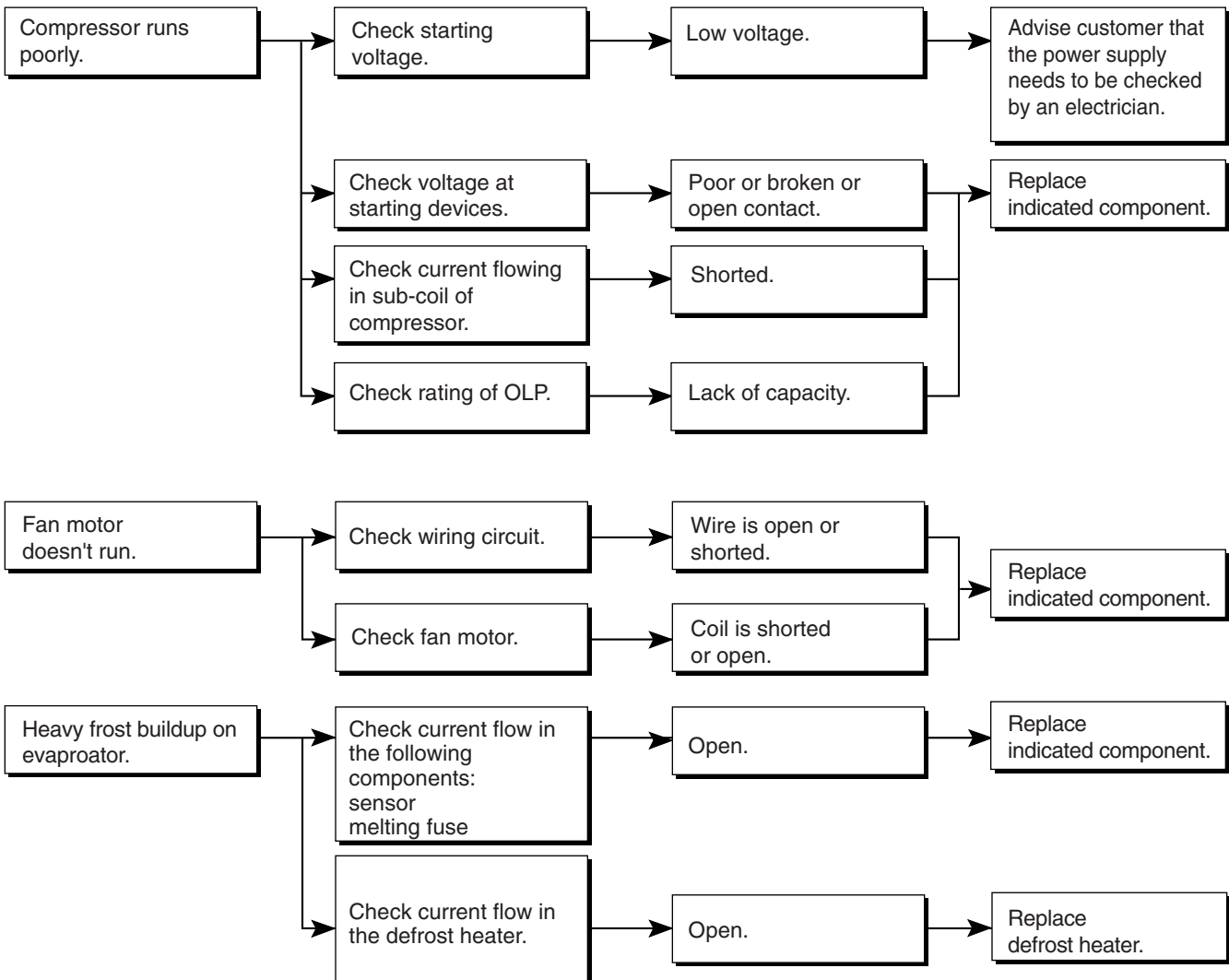

## 6-4 SERVICE DIAGNOSIS CHART

COMPLAINT	POINTS TO BE CHECKED	REMEDY
No Cooling.	<ul style="list-style-type: none"> <li>• Is the power cord unplugged from the outlet?</li> <li>• Check if the power switch is set to OFF.</li> <li>• Check if the fuse of the power switch is shorted.</li> <li>• Measure the voltage of the power outlet.</li> </ul>	<ul style="list-style-type: none"> <li>• Plug into the outlet.</li> <li>• Set the switch to ON.</li> <li>• Replace the fuse.</li> <li>• If the voltage is low, correct the wiring.</li> </ul>
Cools poorly.	<ul style="list-style-type: none"> <li>• Check if the unit is placed too close to the wall.</li> <li>• Check if the unit is placed too close to the stove, gas cooker, or in direct sunlight.</li> <li>• Is the ambient temperature too high or the room door closed?</li> <li>• Check if food put in the refrigerator is hot.</li> <li>• Did you open the door of the unit too often or check if the door is sealed properly?</li> <li>• Check if the Control is set to <b>warm position</b>.</li> </ul>	<ul style="list-style-type: none"> <li>• Place the unit about 4 inches (10 cm) from the wall.</li> <li>• Place the unit away from these heat sources.</li> <li>• Lower the ambient temperature.</li> <li>• Put in foods after they have cooled down.</li> <li>• Don't open the door too often and close it firmly.</li> <li>• Set the control to <b>recommended position</b>.</li> </ul>
Food in the Refrigerator is frozen.	<ul style="list-style-type: none"> <li>• Is food placed in the cooling air outlet?</li> <li>• Check if the control is set to <b>colder position</b>.</li> <li>• Is the ambient temperature below 5°C?</li> </ul>	<ul style="list-style-type: none"> <li>• Place foods in the high-temperature section. (front part)</li> <li>• Set the control to <b>recommended position</b>.</li> <li>• Set the control to <b>warm position</b>.</li> </ul>
Condensation or ice forms inside the unit.	<ul style="list-style-type: none"> <li>• Is liquid food sealed?</li> <li>• Check if food put in the refrigerator is hot.</li> <li>• Did you open the door of the unit too often or check if the door is sealed properly?</li> </ul>	<ul style="list-style-type: none"> <li>• Seal liquid foods with wrap.</li> <li>• Put in foods after they have cooled down.</li> <li>• Don't open the door too often and close it firmly.</li> </ul>
Condensation forms in the Exterior Case.	<ul style="list-style-type: none"> <li>• Check if the ambient temperature and humidity of the surrounding air are high.</li> <li>• Is there a gap in the door gasket?</li> </ul>	<ul style="list-style-type: none"> <li>• Wipe moisture with a dry cloth. It will disappear in low temperature and humidity.</li> <li>• Fill up the gap.</li> </ul>
There is abnormal noise.	<ul style="list-style-type: none"> <li>• Is the unit positioned in a firm and even place?</li> <li>• Are any unnecessary objects placed behind of the unit?</li> <li>• Check if the drip tray is not firmly attached.</li> <li>• Check if the cover of the compressor enclosure in the lower front side is taken out.</li> </ul>	<ul style="list-style-type: none"> <li>• Adjust the leveling screw, and position the refrigerator in a firm place.</li> <li>• Remove the objects.</li> <li>• Fix the drip tray firmly in the original position.</li> <li>• Place the cover in its original position.</li> </ul>
Door does not close well.	<ul style="list-style-type: none"> <li>• Check if the door gasket is dirty with an item like juice.</li> <li>• Is the refrigerator level?</li> <li>• Is there too much food in the refrigerator?</li> </ul>	<ul style="list-style-type: none"> <li>• Clean the door gasket.</li> <li>• Position in a firm place and level the leveling screw.</li> <li>• Make sure food stored in shelves does not prevent the door from closing.</li> </ul>
Ice and foods smell unpleasant.	<ul style="list-style-type: none"> <li>• Check if the inside of the unit is dirty.</li> <li>• Are foods with a strong odor unwrapped?</li> <li>• The unit smells of plastic.</li> </ul>	<ul style="list-style-type: none"> <li>• Clean the inside of the unit.</li> <li>• Wrap foods that have a strong odor.</li> <li>• New products smell of plastic, but this will go away after 1-2 weeks.</li> </ul>

● Other possible problems:

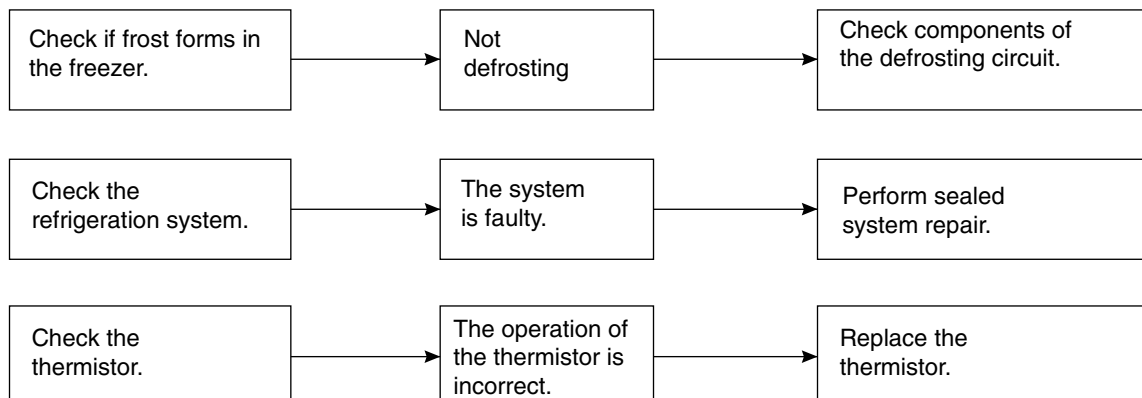



## 6-5 REFRIGERATION CYCLE

### ▼ Troubleshooting Chart

CAUSE		STATE OF THE UNIT	STATE OF THE EVAPORATOR	TEMPERATURE OF THE COMPRESSOR	REMARKS
LEAKAGE	PARTIAL LEAKAGE	Freezer compartment and refrigerator don't cool normally.	Low flowing sound of refrigerant is heard and frost forms in inlet only.	A little higher than ambient temperature.	<ul style="list-style-type: none"> <li>Refrigerant level is low due to a leak.</li> <li>Normal cooling is possible by restoring the normal amount of refrigerant and repairing the leak.</li> </ul>
	COMPLETE LEAKAGE	Freezer compartment and refrigerator don't cool normally.	Flowing sound of refrigerant is not heard and frost isn't formed.	Equal to ambient temperature.	<ul style="list-style-type: none"> <li>No discharging of refrigerant.</li> <li>Normal cooling is possible by restoring the normal amount of refrigerant and repairing the leak.</li> </ul>
CLOGGED BY DUST	PARTIAL CLOG	Freezer compartment and refrigerator don't cool normally.	Flowing sound of refrigerant is heard and frost forms in inlet only.	A little higher than ambient temperature.	<ul style="list-style-type: none"> <li>Normal discharging of the refrigerant.</li> <li>The capillary tube is faulty.</li> </ul>
	WHOLE CLOG	Freezer compartment and refrigerator don't cool.	Flowing sound of refrigerant is not heard and frost isn't formed.	Equal to ambient temperature.	<ul style="list-style-type: none"> <li>Normal discharging of the refrigerant.</li> </ul>
MOISTURE CLOG		Cooling operation stops periodically.	Flowing sound of refrigerant is not heard and frost melts.	Lower than ambient temperature.	<ul style="list-style-type: none"> <li>Cooling operation restarts when heating the inlet of the capillary tube.</li> </ul>
DEFECTIVE COMPRESSION	COMP-RESSION	Freezer and refrigerator don't cool.	Low flowing sound of refrigerant is heard and frost forms in inlet only.	A little higher than ambient temperature.	<ul style="list-style-type: none"> <li>Low pressure at high side of compressor due to low refrigerant level.</li> </ul>
	NO COMP-RESSION	No compressing operation.	Flowing sound of refrigerant is not heard and there is no frost.	Equal to ambient temperature.	<ul style="list-style-type: none"> <li>No pressure in the high pressure part of the compressor.</li> </ul>

6-5-1 SEALED SYSTEM DIAGNOSIS

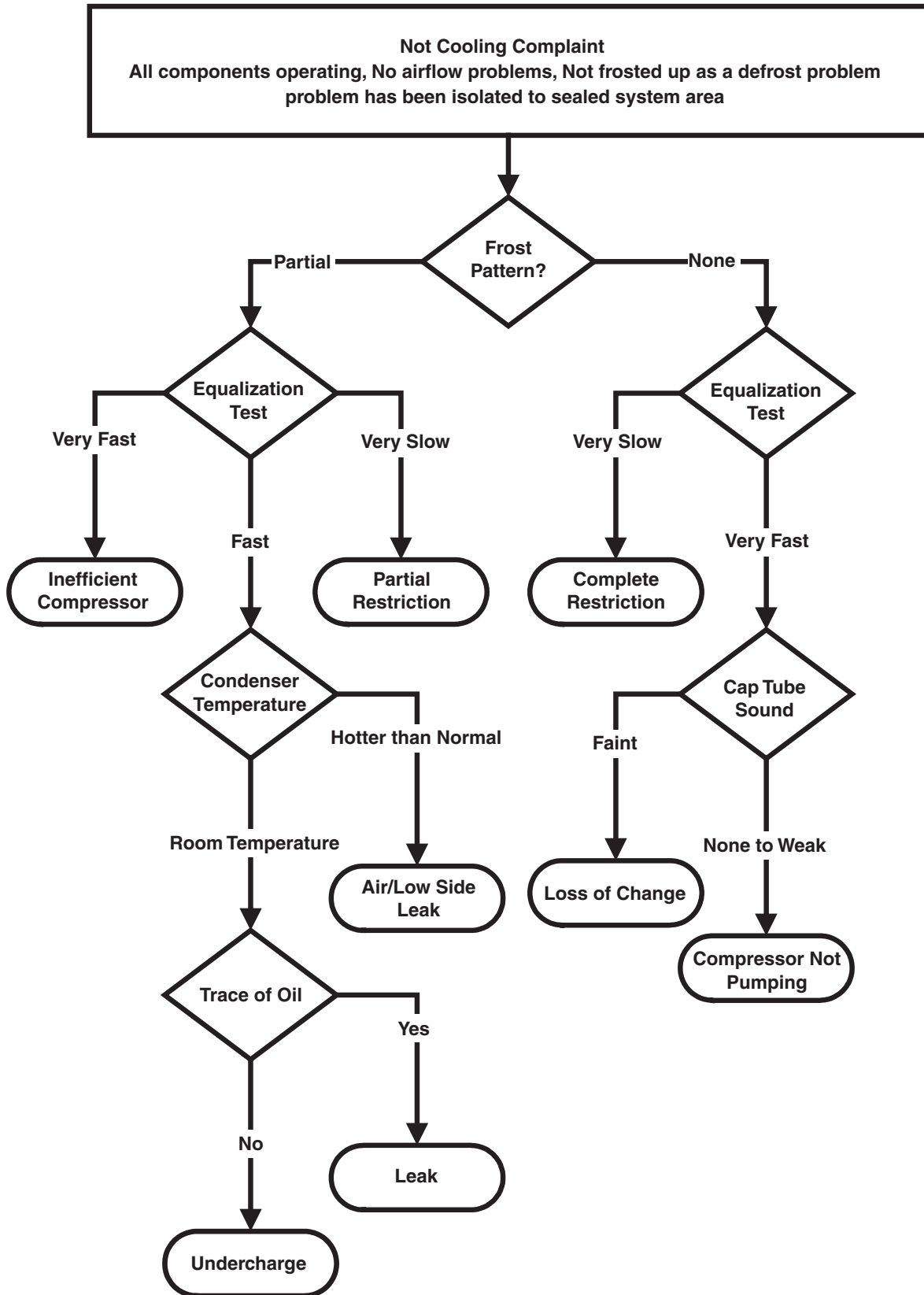

(The equalization test is trying to restart a compressor using a start kit after it has been operating.)

# 7. OPERATION PRINCIPLE AND REPAIR METHOD OF ICEMAKER

## 7-1 OPERATION PRINCIPLE

### 7-1-1 Operation Principle of Icemaker

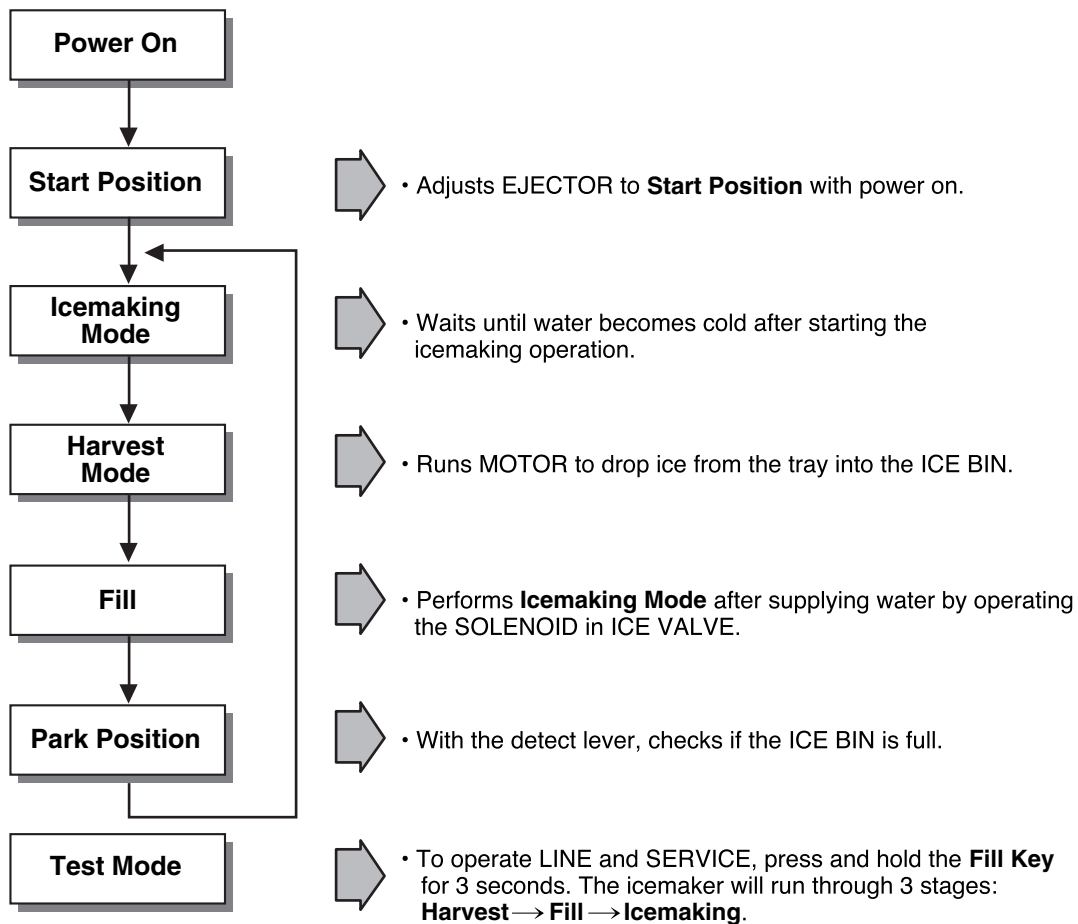

1. Turning the Icemaker stop switch off (O) stops the icemaking function.
2. Setting the Icemaker switch to OFF and then turning it back on will reset the icemaker control.

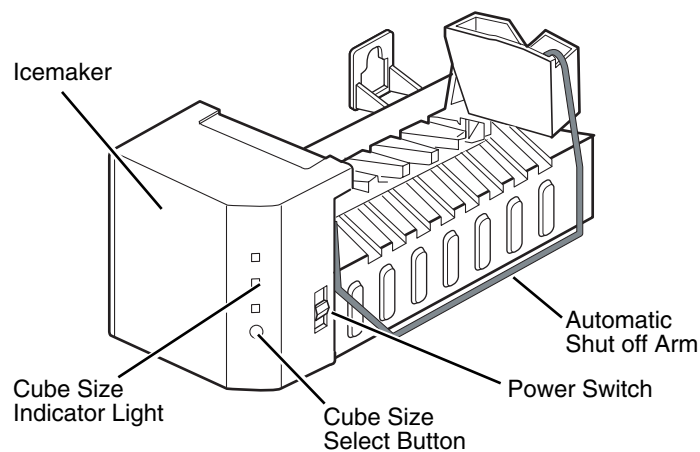

---

## 7-2 ICE MAKER FUNCTIONS

### 7-2-1 Start Position

1. After POWER OFF or power outage, check the EJECTOR's position with MICOM initialization to restart.
2. How to check if it is in place:
  - Check **HIGH/LOW** signals from HALL SENSOR in MICOM PIN.
3. Control method to check if it is in place:
  - (1) EJECTOR is in place,
    - It is an initialized control, so the mode can be changed to ice making control.
  - (2) EJECTOR isn't in place:
    - A. If EJECTOR is back in place within 2 minutes with the motor on, it is being initialized. If not, go to step B.
    - B. If EJECTOR is back in place within 18 minutes after the heater turns from ON to OFF, it is being initialized. If not, it is not functioning. Repeat step B with heater and motor off.

### 7-2-2 Ice Making Mode

1. Icemaking refers to the freezing of supplied water in the ice trays. Complete freezing is assured by measuring the temperature of the Tray with icemaking SENSOR.
2. Icemaking starts after completion of the water fill operation.
3. The icemaking function is completed when the sensor reaches -7°C, 60 to 240 minutes after starting.
4. If the temperature sensor is defective, the icemaking function will be completed in 4 hours.

**NOTE :** After icemaker power is ON, the icemaker heater will be on for test for 9 sec.

### 7-2-3 Harvest Mode

1. Harvest (Ice removing) refers to the operation of dropping ices into the ice bin from the tray when icemaking has completed.
2. Harvest mode:
  - (1) The Heater is ON for 30 seconds, then the motor starts.
  - (2) Harvest mode is completed if it reaches start position again while Heater & Motor are on at the same time.
    - A. ice bin is full : The EJECTOR stops (heater off).
    - B. ice bin is not full : The EJECTOR rotates twice to open for ice.



**NOTE :** If the EJECTOR does not rotate once within 5 minutes in status (2), separate heater control mode starts operating to prevent the EJECTOR from being constrained. (It is recommended that the user open for ice to return to normal mode.)

---

### 7-2-4 Fill/Park Position

1. Once a normal harvest mode has been completed, the water solenoid will be activated.
2. The amount of water is adjusted by pressing the fill key repeatedly. This changes the time allowed for fill as illustrated in the table below.





**Water supply amount table**

STAGE	TIME TO SUPPLY	INDICATIONS	REMARKS
1	6 sec.		The water amount will vary depending on the water control switch setting, as well as the water pressure of the connected water line.
2	7 sec.		
3	8 sec.		

### 7-2-5 Function TEST

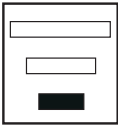
1. This is a compulsory operation for test, service, cleaning, etc. It is operated by pressing and holding the fill key for 3 seconds.
2. The test works only in the icemaking mode. It cannot be entered from the harvest or fill mode. (If there is an ERROR, it can only be checked in the test mode.)
3. **Caution!** If the test is performed before water in the icemaker is frozen, the ejector will pass through the water. When the fill mode begins (stage 4), unless the water supply has been shut off, added water will overflow into the ice bin. If the control doesn't operate normally in the test mode, check and repair as needed.
4. After water is supplied, the normal cycle is followed: **icemaking** → **harvest** → **fill** → **park position**.
5. Five seconds after stage 5 is completed, the icemaker returns to MICOM control. The time needed to supply water resets to the pre-test setting.

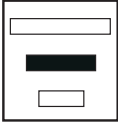
#### < 5 stage of diagnosis >

STAGE	ITEMS	INDICATOR	REMARKS
1	HEATER		Five seconds after heater starts, heater will go off if temperature recorded by sensor is 50°F(10°C) or lever is in up position.
2	MOTOR		Five seconds after heater starts, you can confirm that motor is moving.
3	HALL IC I (detection of position)		You can confirm hall ic detection of position.
4	VALVE		Two seconds after detection of initial position, you can confirm that valve is on.
5	HALL IC II (detection of full-filled Ice)		You can check whether the Hall IC is sensing a full ice condition.(If there is a full-filled error, the fifth stage would not be progressed)
6	Reset	Mark previous status on TEST mode	Five seconds after fifth stage is completed, the icemaker resets to initial status.

### 7-3 DEFECT DIAGNOSIS FUNCTION

#### 7-3-1 ERROR CODE on water supply control panel at Ice Maker

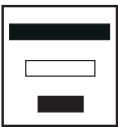
No	ITEM	ERROR CODE	CONTENTS	REMARKS
1	Normal	Mark time to supply	None	Display switch operates properly
2	Ice-Making Sensor malfunction		Open or short-circuited wire	Make sure that the wire on each sensor is connected.

\* ERROR indicators in table can be checked only on TEST mode.

# 8. DESCRIPTION OF FUNCTION & CIRCUIT OF MICOM

## 8-1 FUNCTION

### 8-1-1 Function

1. When the appliance is plugged in, it defaults to 37°F for the refrigerator and 0°F for the freezer.  
You can adjust the refrigerator and the freezer control temperature by pressing the ADJUST button.
2. When the power is initially applied or restored after a power failure, it is automatically set to 37 & 0.

### Best Model

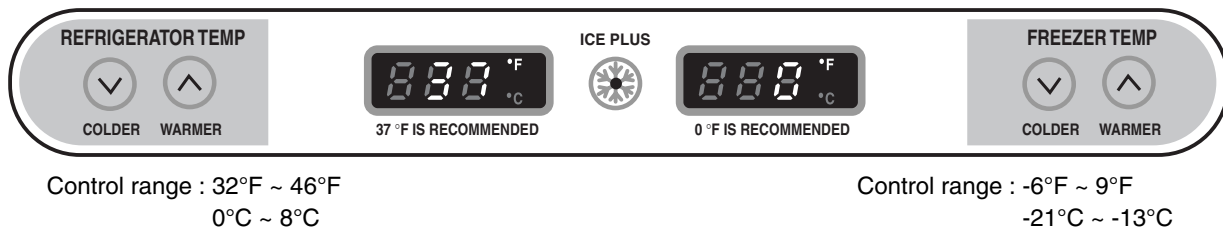

### 8-1-2 How to Change the Temperature Mode to °F/°C

1. The display temperature mode can be changed from °F to °C or °C to °F by pressing and holding the FRZ TEMP and the COLDER key of REF TEMP keys at the same time for over five seconds
2. The initial setting is °F. Whenever the mode is changed, the LED lights are changed.

### 8-1-3 Control of freezer fan motor

1. Freezer fan motor runs at either regular or high speed.(2,400 or 2,700 rpm.)
2. High RPM is used when electricity is first on, for ICE PLUS, and when refrigerator is overloaded.  
Standard RPM is used for normal usage.
3. The fan motor is stopped when any door is opened.

### 8-1-4 ICE PLUS

1. The purpose of this function is to intensify the cooling speed of freezer and to increase the amount of ice.
2. Whenever selection switch is pressed, selection/release, the icon will turn ON or OFF.
3. If there is a power outage and the refrigerator is powered on again, ICE PLUS will be canceled.
4. To activate this function you need to press the ICE PLUS key and the icon will turn ON. This function will remain activated for 24 hours. The first three hours the compressor and freezer fan will be ON. The next 21 hours the freezer will be controlled at the lowest temperature. After 24 hours or if the ICE PLUS key is pressed again, the freezer will return to its previous temperature.
5. During the first 3 hours:
  - (1) Compressor and freezer fan (HIGH RPM) run continuously.
  - (2) If a defrost cycle begins during the first 90 minutes of ICE PLUS, the ICE PLUS cycle will complete its cycle after defrosting has ended. If the defrost cycle begins when ICE PLUS has run for more than 90 minutes, ICE PLUS will run for two hours after the defrost is completed.
  - (3) If ICE PLUS is pressed during defrost, ICE PLUS icon is on this function will start seven minutes after defrost is completed and it shall operate for three hours.
  - (4) If ICE PLUS is selected within seven minutes after compressor has stopped, the compressor (compressor delays seven minutes) will start after the balance of the delay time.
  - (5) The fan motor in the freezer compartment rotates at high speed during ICE PLUS.
6. For the rest of 21 hours, the freezer will be controlled at the lowest temperature.

### 8-1-5. REFRIGERATOR LAMP AUTO OFF

1. To protect the risk of lamp heat, when the refrigerator door is opened for 7 minutes, the refrigerator lamp will be turned off automatically.

---

### 8-1-6 Alarm for Open Door

1. This feature sounds a buzzer when the freezer or refrigerator door is not closed within 1 minute after it is opened.
2. One minute after the door is opened, the buzzer sounds three times each for 1/2 second. These tones repeat every 30 seconds.
3. The alarm is cancelled when the freezer or the refrigerator is closed while the buzzer sounds.

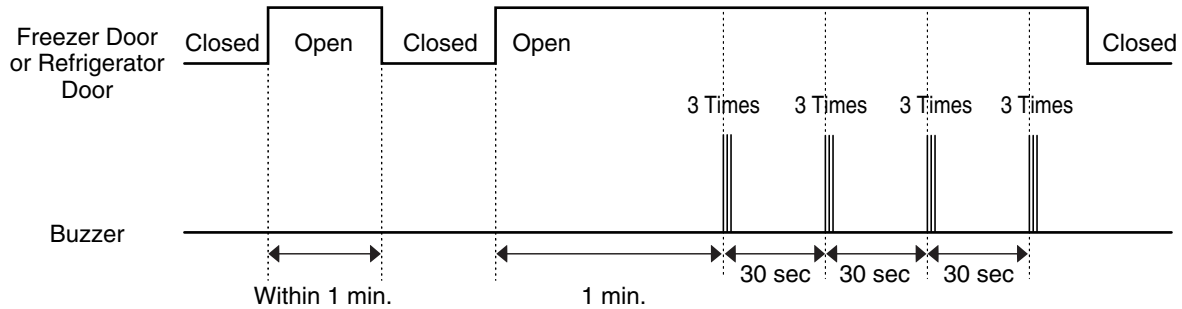

### 8-1-7 Buzzer Sound

When the button on the front display is pushed, a Ding~ Dong~ sound is produced.

### 8-1-8 Defrosting (removing frost)

1. Defrosting starts each time the compressor running time reaches 7 hours.
2. For initial power on or for restoring power, defrosting starts when the compressor running time reaches 4 hours.
3. Defrosting stops if the sensor temperature reaches 8°C or more. If the sensor doesn't reach 8°C in 2 hours, the defrost mode is malfunctioning.
4. Defrosting won't function if its sensor is defective (wires are cut or short circuited)



### 8-1-9 Electrical Parts Are Turned On Sequentially

Electrical parts such as compressor, defrosting heater, freezer fan, etc. are turned on in the following order to prevent noise and parts damage. Several parts are started at the same time at initial power on and are turned off together when test is completed.

OPERATING		ORDERS				
Initial power on	Temperature of defrosting sensor is 45°C or more (when unit is newly purchased or when moved)	<b>Power ON</b>	in 0.5 sec. →	<b>Compressor ON</b>	in 0.5 sec. →	<b>Freezer fan ON</b>
	Temperature of defrosting sensor is lower than 45°C (during power outages or for service)	<b>Power ON</b>	in 0.5 sec. →	<b>Defrosting heater ON</b>	in 10 sec. →	<b>Defrost heater OFF</b>
		in 0.5 sec. →	<b>Compressor ON</b>	in 0.5 sec. →	<b>Freezer fan ON</b>	
	Reset to normal operation from test mode	<b>Total load OFF</b>	in 7 min. →	<b>Compressor ON</b>	in 0.5 sec. →	<b>Freezer fan ON</b>

## 8-1-10 Defect Diagnosis Function

1. Automatic diagnosis makes servicing the refrigerator easy.
2. When a defect occurs, the buttons will not operate; but the tones, such as ding, will sound.
3. When the defect CODE removes the sign, it returns to normal operation (RESET).
4. The defect CODE shows on the refrigerator and freezer display.

### Best Model

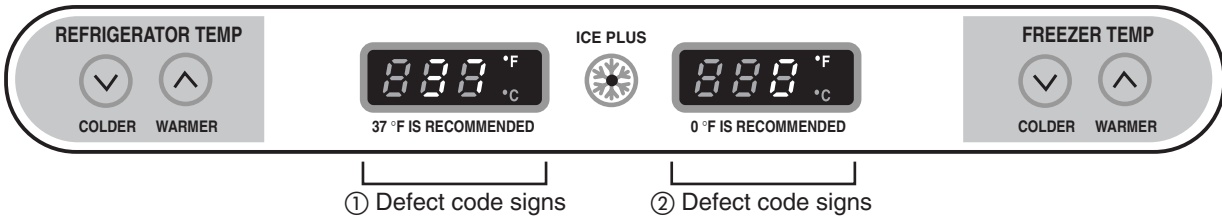

### ERROR CODE on display panel

NO	ITEM	ERROR CODE		CONTENTS	REMARKS
		①	②		
1	Failure of freezer sensor	Er	FS	Cut or short circuit wire	Inspect Connecting wires on each sensor
2	Failure of Refrigerator sensor	Er	rS	Cut or short circuit wire	
3	Failure of defrost sensor	Er	dS	Cut or short circuit wire	
4	Failure of Room Temperature sensor	When display check mode:Er rt		Cut or short circuit wire	
5	Failure of defrost mode	Er	dH	When defrost sensor doesn't reach 46°F(8°C) within 2hours after starting defrost	Snapping of defrost heater or Temperature fuse, pull-out of connector (indicated minimum 2 hours after failure occurs)
6	Failure of BLDC Fan Motor at Freezing Compartment	Er	FF	If there is no fan motor signal for more than 65sec in operation fan motor	Poor motor, hooking to wires of fan, contact of structures to fan, snapping or short circuit of Lead wires
7	Failure of BLDC Fan Motor a Mechanical Room	Er	CF	If there is no fan motor signal for more than 115sec in operation fan motor	Poor motor, hooking to wires of fan, contact of structures to fan, snapping or short circuit of Lead wires

Note 1) Room temperature sensor is not indicated on the failure indicating part but indicated in checking display. (When pressing for more than the warmer key of refrigerator temp and the warmer key of freezer temp for more than 1 second).

\* LED check function: If press and hold the warmer key of refrigerator temp and the warmer key of freezer temp for a second, all display LED graphics on. When you release the buttons, the LED graphics displays the previous status.

## 8-1-11 TEST Mode

1. The test mode allows checking the PCB and the function of the product as well as finding out the defective part in case of an error.
2. The test mode is operated by pressing two buttons on the display panel.
3. While in the test mode, the function control button is not recognized, but the recognition tone (beep~) sounds.
4. After exiting the test mode, be sure to reset by unplugging and then plugging in the appliance.
5. If an error, such as a sensor failure, is detected while in the test mode, the test mode is cleared and the error code is displayed.
6. While an error code is displayed, the test mode will not be activated.

MODE	MANIPULATION	CONTENTS	REMARKS
TEST1	Push Express Freezing Key and COLDER KEY of Freezer Temp at the same time over 3seconds OR Push TEST S/W (in the main Board)once.	1) Continuous operation of the COMPRESSOR and the Freezer fan 2) Stepping DAMPER OPEN 3) Defrosting HEATER OFF 4) DISPLAY LED all ON	
TEST2	Push Express Freezing Key and COLDER KEY of Freezer Temp at the same time over 3 seconds in TEST MODE 1 OR Push TEST S/W once in TEST MODE 1	1) Continuous operation of the COMPRESSOR and the Freezer fan 2) Stepping DAMPER CLOSE 3) Defrosting HEATER OFF 4) DISPLAY LED shows no. 2	
TEST3	Push Express Freezing Key and COLDER KEY of Freezer Temp at the same time over 3 seconds in TEST MODE 2 OR Push TEST S/W once in TEST MODE 2	1) COMPRESSOR and the Freezer fan OFF 2) Stepping DAMPER CLOSE 3) Defrosting HEATER ON 4) DISPLAY LED shows no. 3	Reset if the Temperature of the Defrosting Sensor is 46°F(8°C)or more.
RESET	Push Express Freezing Key and COLDER KEY of Freezer Temp at the same time over 3 seconds in TEST MODE 3 OR Push TEST S/W once in TEST MODE 3	Reset to the previously setting Before TEST MODE.	The compressor will Start after a 7-minute Delay.

### \* Freezer Fan Variable RPM Check:

To check the variable rpm, press and hold the WARMER keys of both the REF TEMP and FRX TEMP. The fan speed will change (low to high or high to low) for 30 seconds before reverting to its original setting.

### \* Demonstration (Display) MODE:

1. To enter this mode, raise either the Refrigerator or Freezer temperature to its highest setting. Then, press and hold WARMER Key for 5 seconds.
2. The LED panels will display OFF, to indicate that the compressor, circulating fan, damper, and defrost heater are not operating.
3. The open door alarm and the lamp auto-off feature will work normally and can be demonstrated.
4. To reset to normal operation, press and hold either WARMER key for about 5 seconds.

## 8-2 PCB FUNCTION

### 8-2-1 Power Circuit

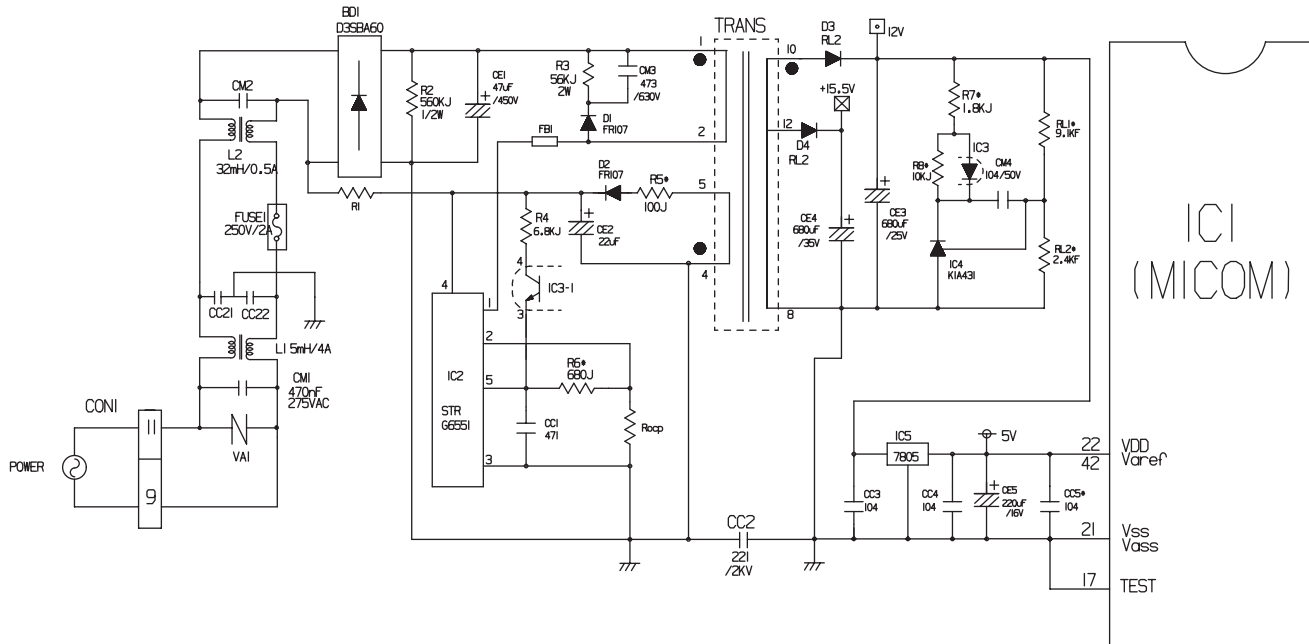

The secondary part of the TRANSFORMER is composed of the power supply for the display, the BLDC FAN Motor drive (15.5 V), the relay drive (12 Vdc) and the MICOM and IC (5 Vdc).

The voltage for each part is as follows:

PART	VA 1	CE 3	CE 4	CE 5
VOLTAGE	115 Vac	12 Vdc	15.5 Vdc	5 V

VA1 is a part for preventing over voltage and noise. When 385V or higher power is applied, the inside elements are short-circuited and broken, resulting in blowout of the fuse in order to protect the elements of the secondary part of the TRANSFORMER.

### 8-2-2 Oscillation Circuit

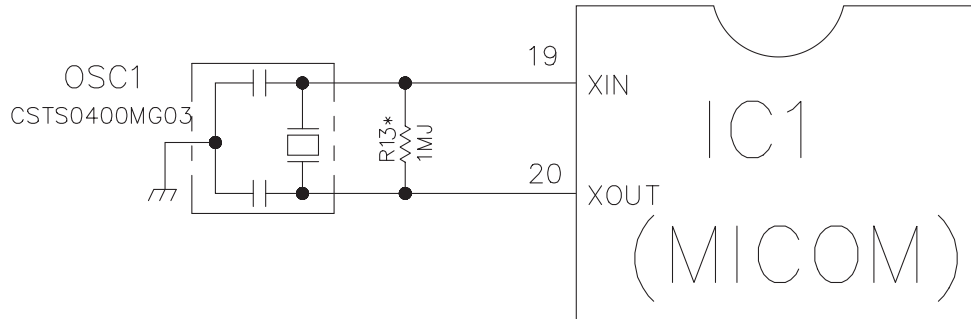

This circuit generates the base clock for calculating time and the synchro clock for transmitting data from and to the inside logic elements of the IC1 (MICOM). Be sure to use specified replacement parts, since calculating time by the IC1 may be changed. If changed, the OSC1 SPEC will not work.

### 8-2-3 Reset Circuit

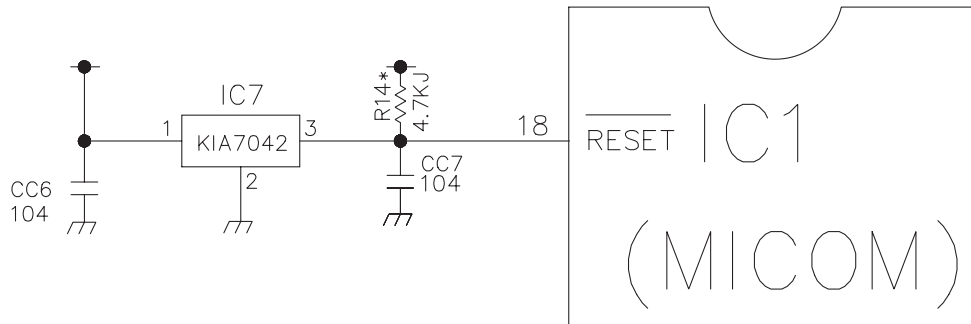

The RESET circuit allows all the functions to start at the initial conditions by initializing various parts, including the RAM inside the MICOM (IC1) when the power is initially supplied or the power supply to the MICOM is restored after a momentary power failure. For the initial 10ms of power supply, LOW voltage is applied to the MICOM RESET terminal. During a normal operation, 5V is applied to the RESET terminal. (If a malfunction occurs in the RESET IC, the MICOM will not operate.)

## 8-2-4 Load / Buzzer Drive & Open Door Detection Circuit

### 1. Load Drive Condition Check

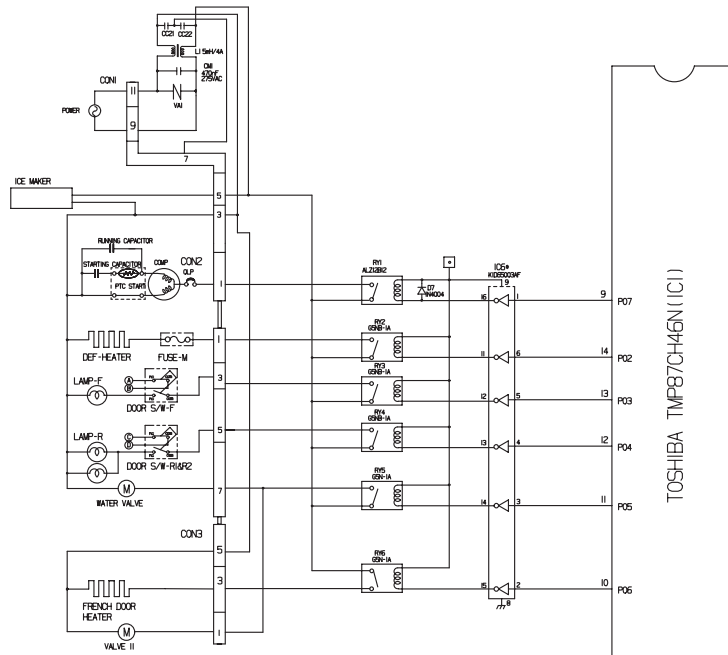

LOAD TYPE		COMP	DEFROSTING HEATER	LAMP-F	LAMP-R	WATER VALVE/VALVE2	FRENCH DOOR HEATER
Measurement Location (IC6)		NO.16	NO.11	NO.12	NO.13	NO.14	NO.15
Condition	ON	1V or below					
	OFF	12V					

### 2. Fan motor driving circuit (freezer compartment fan)

1. This circuit makes standby power 0 by cutting off power supplied to ISs inside of the fan motor in the fan motor OFF.
2. This is a circuit to perform a temporary change of speed for the fan motor and applies DC voltage up to 7.5V ~ 16V to motor.
3. This circuit prevents over-driving the fan motor by cutting off power applied to the fan motor in the lock of fan motor by sensing the operation RPM of the fan motor.

	Ⓐ part	Ⓑ part	Ⓒ part
MOTOR OFF	2V or less	0V	5V
MOTOR ON	13V~15V	0V	2V~3V

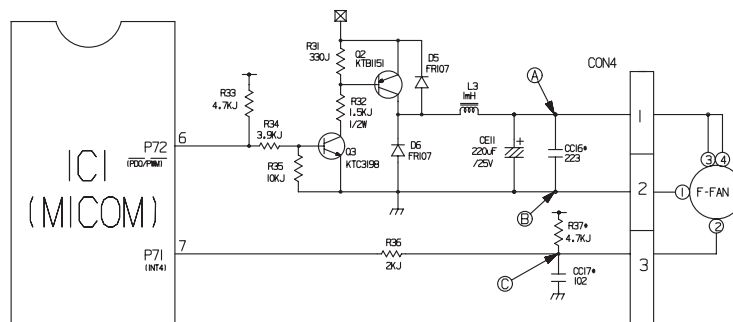

## 2. Open Door Detection Circuit Check

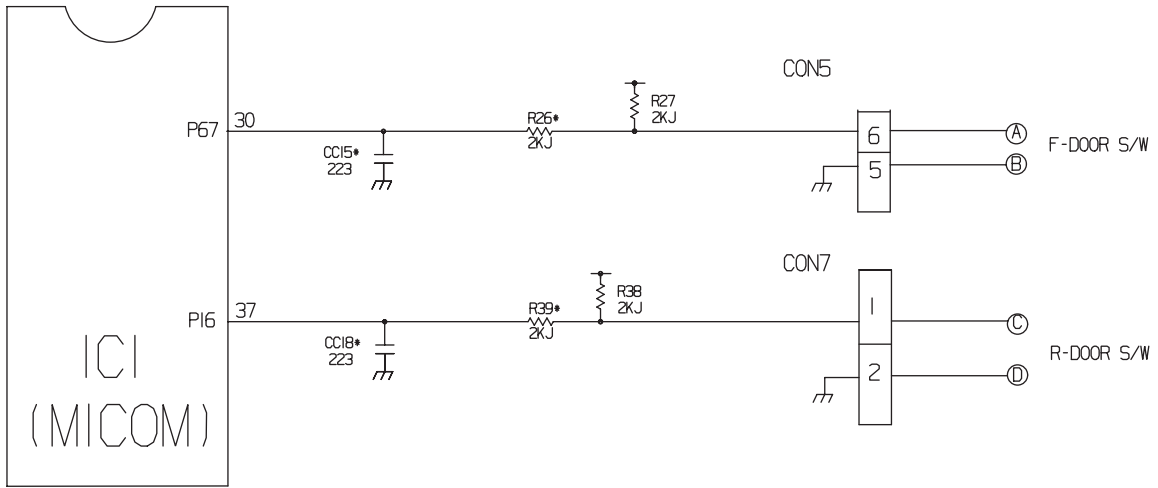

Freezer/ Refrigerator Door	Measurement Location	(PIN NO.30 & PIN NO.27)
	Closed	5 V
	Open	0 V

### 8-2-5 Temperature Sensor Circuit

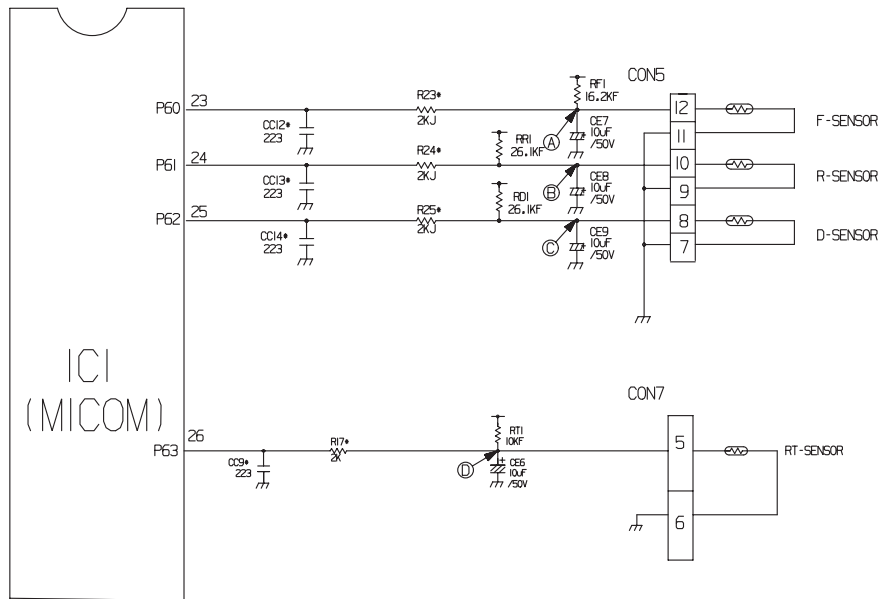

The upper circuit reads refrigerator temperature, freezer temperature, and defrost sensor temperature for defrosting and the indoor temperature for compensating for the surrounding temperature into MICOM.

Opening or short state of each temperature sensor are as follows:

SENSOR	CHECK POINT	NORMAL (-30°C ~ 50°C)	SHORT-CIRCUITED	OPEN
Freezer sensor	POINT (A) Voltage	0.5 V ~ 4.5 V	0 V	5 V
Refrigerator sensor	POINT (B) Voltage			
Defrosting sensor	POINT (C) Voltage			
Room Temperature sensor	POINT (D) Voltage			

### 8-2-6 Refrigeration Compartment Stepping Motor Damper Circuit

\* The circuit shown below is the damper circuit to regulate the refrigerator temperature.

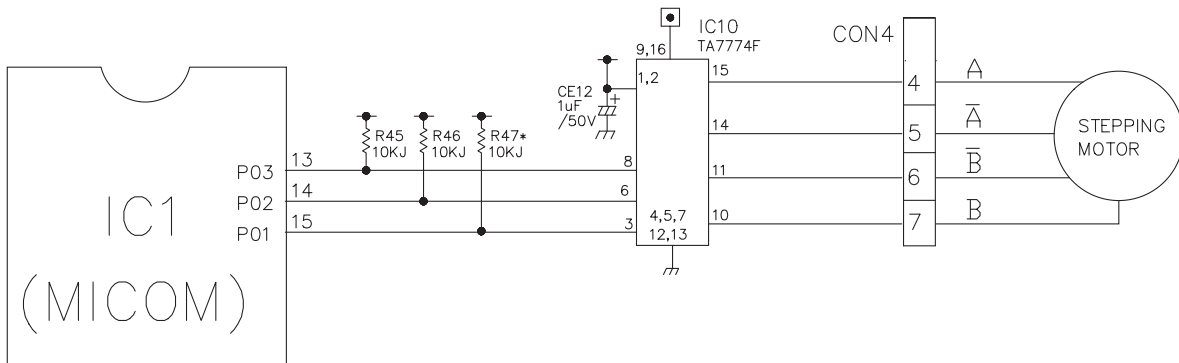



---

### 8-3 RESISTANCE SPECIFICATION OF SENSOR

TEMPERATURE	RESISTANCE OF FREEZER SENSOR	RESISTANCE OF REFRIGERATOR & DEFROST SENSOR & ROOM SENSOR
- 20 °C	22.3 KΩ	77 KΩ
- 15 °C	16.9 KΩ	60 KΩ
- 10 °C	13.0 KΩ	47.3 KΩ
- 5 °C	10.1 KΩ	38.4 KΩ
0 °C	7.8 KΩ	30 KΩ
+ 5 °C	6.2 KΩ	24.1 KΩ
+ 10 °C	4.9 KΩ	19.5 KΩ
+ 15 °C	3.9 KΩ	15.9 KΩ
+ 20 °C	3.1 KΩ	13 KΩ
+ 25 °C	2.5 KΩ	11 KΩ
+ 30 °C	2.0 KΩ	8.9 KΩ
+ 40 °C	1.4 KΩ	6.2 KΩ
+ 50 °C	0.8 KΩ	4.3 KΩ

- The resistance of the SENSOR has a  $\pm 5\%$  tolerance.
- Measure the resistance of the SENSOR after leaving it for over 3 minutes in the measuring temperature. This delay is necessary due to sensor response speed.

## 8-4 TROUBLESHOOTING

PROBLEM	INDICATED BY	CHECK	CHECKING METHOD	CAUSE	SOLUTION	
Power source is poor.	1. The whole DISPLAY LED/SEVEN SEGMENT DISPLAY is off. 2. DISPLAY LED/SEVEN SEGMENT DISPLAY operates abnormally	1. FREEZER/REFRIGERATOR.	Check if freezer or refrigerator door is open and check display.	Power source is poor.	Check outlet voltage.	
		2. If lamp is dim.	Check visually.	Applied voltage error.	Use boosting transformer.	
Cooling is poor.	No cooling.	3. The connection of the main PWB connector.	Check connection of connector.	connector connection is poor.	Reconnect connector.	
		1. If the compressor operates.	Use Test Mode <sup>1</sup> (forced cooling). If less than 7 minutes pass after compressor shuts off, don't press the key and wait.	Transformer fuse is open.	Replace transformer.	
Cooling is poor.	No cooling.	2. If refrigerant is leaking.	Measure the amount of frost sticking on evaporator and the surface temperature of the condenser pipe.	Compressor locked or blocked.	Replace compressor.	
				OLP, PTC, or compressor are failed.	Replace OLP, PTC. Replace main PWB.	
		1. If fan motor operates.	Use Test Mode <sup>1</sup> (forced cooling).	Connection wire is defective.	Check the connection of the black wire of the main PWB connector (CON2).	
				Refrigerant leakage.	Replace the leaking part and replace any lost refrigerant.	
Freezer temperature is incorrect	1. If fan motor operates.	1. If fan motor operates.	Use Test Mode <sup>1</sup> (forced cooling).	Fan motor is defective.	Replace the fan motor.	
				Connection wire is defective.	Refer to 8-2-4. 2 and check	
				2. If defrosting is normal.	Defrosting is poor.	See <b>DEFROSTING is poor</b> , page 34.
				3. If sensor is normal.	Sensor resistance is incorrect.	Replace sensor.
Freezer temperature is incorrect.	1. If fan motor operates.	4. Gasket seal incorrect.	Check the seal when the door is closed.	Door liner damaged.	Replace door liner.	

PROBLEM	INDICATED BY	CHECK	CHECKING METHOD	CAUSE	SOLUTION
COOLING is defective.	If refrigerator temperature is too low.	1. If freezer temperature is normal.	Check if freezer temperature is too low.	FAN motor is defective.	Make sure the door is attached. Replace fan motor.
		2. If amount of cool air from fan motor is sufficient.	Make sure that the amount and speed of cool air are sufficient by touching the check supplied on the refrigerator.	Passage of cool air is blocked. Evaporator frozen.	Remove impurities. See <b>defrosting is poor</b> , below.
		3. Door gasket contact.	Check door seal when door is closed.	Door liner damaged.	Replace door liner.
DEFROSTING is defective.	NO defrosting.	1. If heater emits heat.	USE TEST MODE3 (forced defrosting).	Heater disconnection.	Replace heater.
				Temperature fuse is blown.	Replace temperature fuse.
				Connection is poor.	Check evaporator connection and wire of main PWB connector.
				Defrost sensor is defective.	Replace defrost sensor.
				Heater relay is poor.	Replace RY2 of main PWB.
3. If ice remains after defrosting.	3. If ice remains after defrosting.	3. If ice remains after defrosting.	Make sure that defrost sensor is connected. Make sure that freezer and refrigerator doors are closed.	Drain pipe is blocked.	Remove ice and impurities. Check heater plate resistance.
				Connection is poor.	Reassemble the defrost sensor.
				Door does not close properly.	Reassemble door. Replace gasket.

# 8-5 MAIN PWB ASSEMBLY AND PARTS LIST

## 8-5-1 Main PWB Assembly

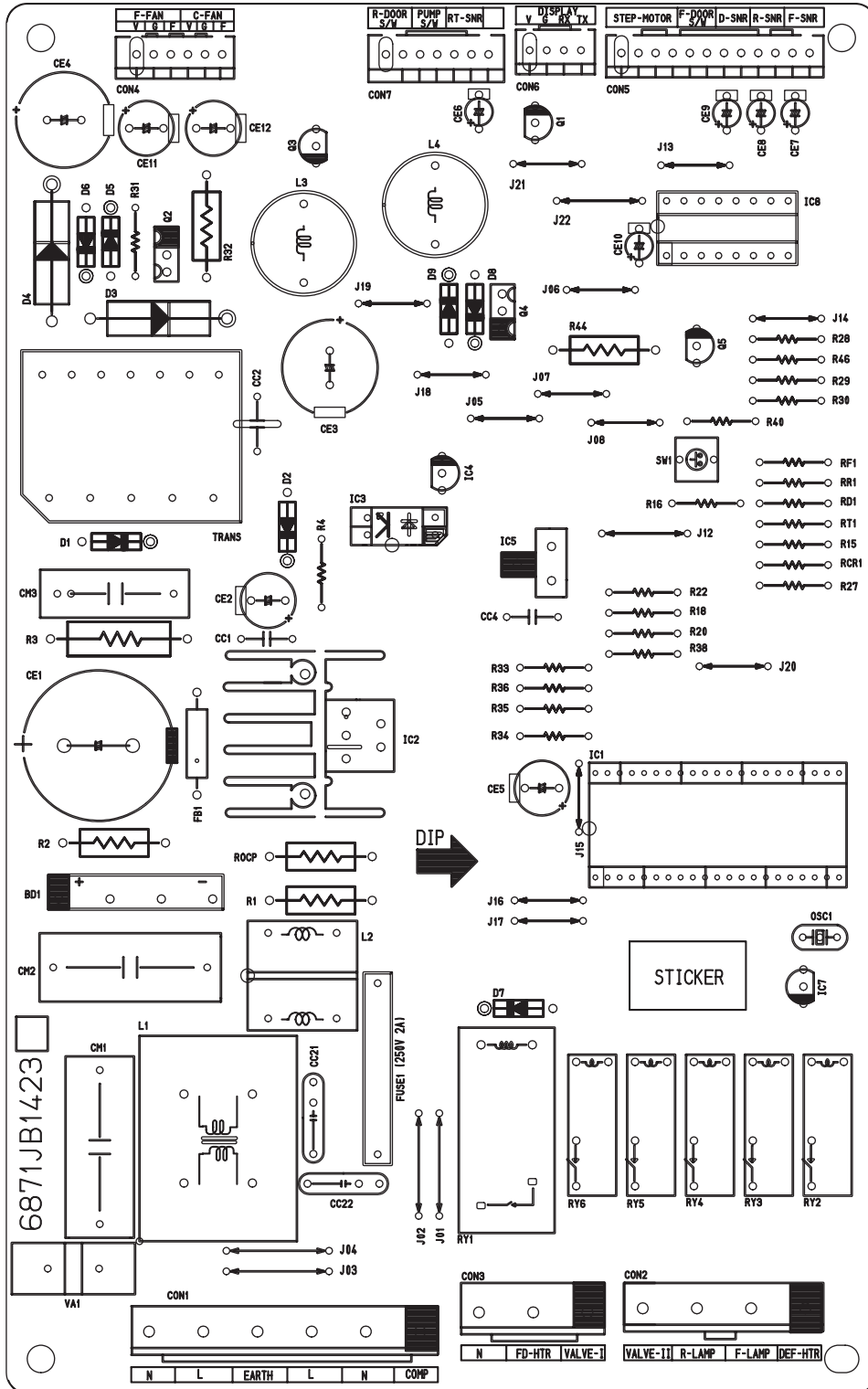



### 8-5-3 PWB Assembly, Display, And Parts List



Qty	No	P/NO	DESCRIPTION	SPEC	MAKER	REMARK
1	1	6670JB919A	PWB(PCB)	ERAVO 33 DISPLAY	DOOSAN	L6T
-	2	-	-	-	-	-
-	3	-	-	-	-	-
1	4	-	-	-	-	-
1	5	-	-	-	-	-
1	6	-	-	-	-	-
-	7	-	-	-	-	-
-	8	-	-	-	-	-
-	9	-	-	-	-	-
1	10	6630JB005C	CONNECTOR (CIRC), WAFER	SWAK250-04	YEON HO	CON01
11	11	Q1ZZJB203A	IC, DRAWING	TMF970309M 28, 50P28-P-450 ERAVO 33	TOSHIBA	IC1
1	12	Q1ZZJB205P	IC, DRAWING	TMF970309M 28, 50P28-P-450 ERAVO ELDC-BETTER	TOSHIBA	IC1
-	13	-	-	-	-	-
-	14	-	-	-	-	-
-	15	-	-	-	-	-
-	16	-	-	-	-	-
1	17	0151LM001A	IC, STANDARD LOGIC	M54563FP MITSUBISHI 20 R/TP CONVERT	MITSUBISHI	IC4
1	18	01K650030C	IC, DRIVE	K1D5003AF 16SP BK 70H DRIVER	KEC	IC5, IC6
1	19	0151KE002A	IC, STANDARD LOGIC	LIJ2003A TOSHIBA 10PINSOP TAPPING NFN TRARRAY	TOSHIBA	IC1
1	20	0151KE003A	IC, STANDARD LOGIC	K1A78L09F KEC SOT-89 TP REGULATOR	KEC	IC2
1	21	0151KE005A	IC, STANDARD LOGIC	K1A7042AF KEC SOT-89 TP RESET IC	KEC	IC3
-	22	-	-	-	-	01
-	23	-	-	-	-	KEC, CHANGJIANG
-	24	-	-	-	-	-
1	24	6212B6245A	RESONATOR CERAMIC	C5TOR4M00653-R0 MURATA 4.0MHZ +/- 0.5% T/R SMD	MURATA	OSC1
1	25	03E476V6DC	CAPACITOR, FIXED ELECT	47UF MV 25V 20% R/TP(SMD) SMD	SAMWHA	CE2
1	26	03E107VF6DC	CAPACITOR, FIXED ELECT	100UF MV 16V 20% R/TP(SMD) SMD	SAMWHA	CE1
-	27	-	-	-	-	-
7	28	00X104DK94A	CAPACITOR, FIXED CERAMIC	100NF 2012 50V 60%, -20% R/TP F(Y5V1)	MURATA	CC1-CC7
2	29	00X102DK96A	CAPACITOR, FIXED CERAMIC	1NF 2012 50V 60%, -20% R/TP X7R	MURATA	CC8-CC9
-	30	-	-	-	-	-
-	31	-	-	-	-	-
1	32	0RH2200L622	RESISTOR METAL GLAZED (CHIP)	220 OHM 1/8 W 2012 5.00% D	ROHM	R5
2	33	0FD1001E672	RESISTOR METAL GLAZED (CHIP)	1K OHM 1/8 W 5% 2012 R/TP	ROHM	R3, R4
1	34	0RD2001E672	RESISTOR METAL GLAZED (CHIP)	2K OHM 1/8 W 5% 2012 R/TP	ROHM	R2
6	35	0RD4701E672	RESISTOR METAL GLAZED (CHIP)	4.7K OHM 1/8 W 5% 2012 R/TP	ROHM	R1, R7, R21-R24
1	36	0RD1004E672	RESISTOR METAL GLAZED (CHIP)	1M OHM 1/8 W 5% 2012 R/TP	ROHM	R6
9	37	0RL8200H672	RESISTOR METAL GLAZED (CHIP)	820 OHM 1/2 W 5% 2012 R/TP	ROHM	R8-R16
2	38	0RH2200L622	RESISTOR METAL GLAZED (CHIP)	2K OHM 1/8 W 2012 5.00% D	ROHM	R17, R19
2	39	0RH1000L622	RESISTOR METAL GLAZED (CHIP)	100 OHM 1/2 W 5% 2012 R/TP	ROHM	R18, R20
-	40	-	-	-	-	-
1	41	0D2PM0018BA	DIODE ZENERS	RLZ 0HM R/TP LLD5(LL-34) 500MW 5.6V 20MA .PF	ROHM	ZD1
7	42	0D5FM00068A	DIODE SWITCHING	RLS4148 ROHM R/TP LLD5(LL-34) 75V 450MA 2000MA	ROHM	D107-D113
-	43	0DD414809AA	DIODE SWITCHING	1N4148 26 MM	PYUNG CHANG DELTA	-
-	44	-	-	-	-	-
4	45	6327JB001A	DISPLAY LED ASSEMBLY	LN4022-130HFS GREEN 2, IV 1, 7MCD	LEDTECH	SEG1, SEG2
5	46	0DLLE0059AA	LED	LT8323-41-BON 2, IV D3 TP GREEN	LEDTECH	LI02-LI06
-	47	0DLLE0059AA	LED	LT8323-41-BON 2, IV D3 TP GREEN	LEDTECH	LI01, LI07
1	48	6608JB3002D	BUZZER	PQ272207FL-20C-2000 SUNWAY PIEZO 2KHZ 60DB (CHINA)	SUNWAY	BLZZER
-	49	-	-	-	-	-
-	50	6600RRT005A	SWITCH TACT	KPS-1105AM KYUNG IN(HKI) 12VDC 50 MA SMD	KYUNG IN	-
5	51	6600JB8004A 6600RRT002K	SWITCH TACT	KPT-15R JTP1230A JEIL 12V DC 50MA	KYUNG IN JEIL	SW102-SW105
2	52	6600JB8004A 6600RRT002K	SWITCH TACT	KPT-15R JTP1230A JEIL 12V DC 50MA	KYUNG IN JEIL	SW101, SW107
2g	53	SS0000008AA	-	SR-34 PB FREE, LFM-48	HUSUNG	-
5g	54	SS0000019AA	Metal cream	LFM-48M TM-TS PB FREE HEESUNG METAL CREAM SWAGOU SN+3.0AG+0.50LX	HUSUNG	-
0.5g	55	-	-	-	KOKI	-

# 8-6 PWB DIAGRAM

## 8-6-1 PWB Main Assembly

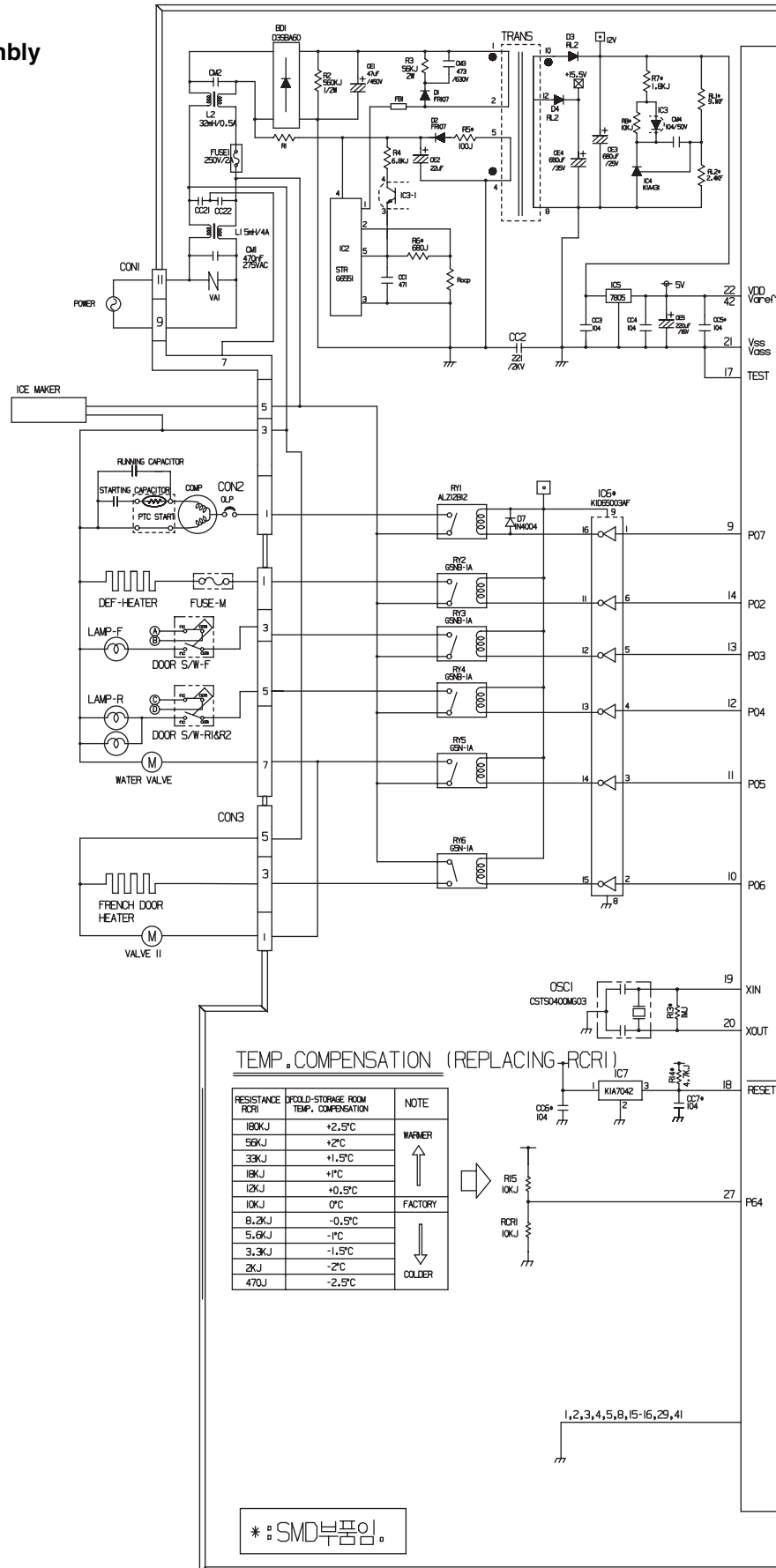
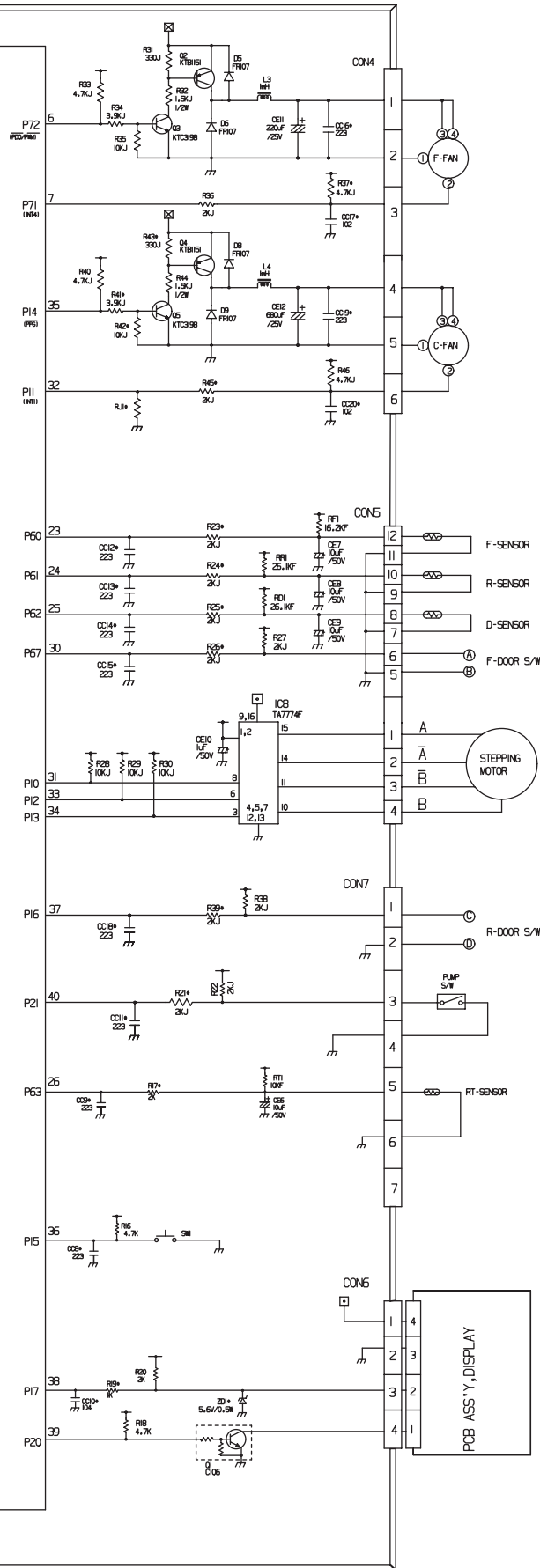

FIG. 1





# 9. EXPLODED VIEW & REPLACEMENT PARTS LIST

## CASE PARTS

CAUTION: Use the part number to order part, not the position number.

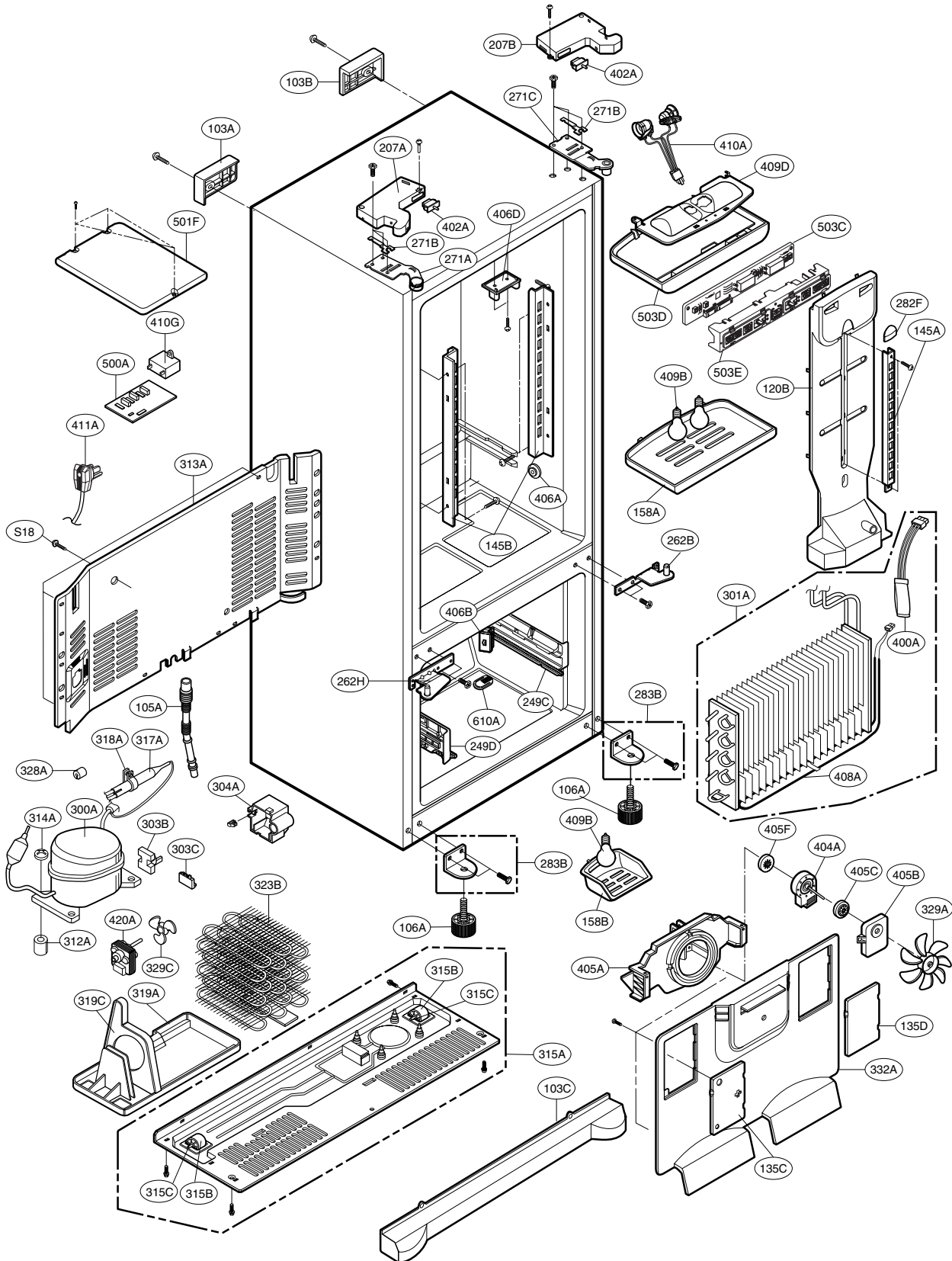

---

## FREEZER PARTS

CAUTION: Use the part number to order part, not the position number.

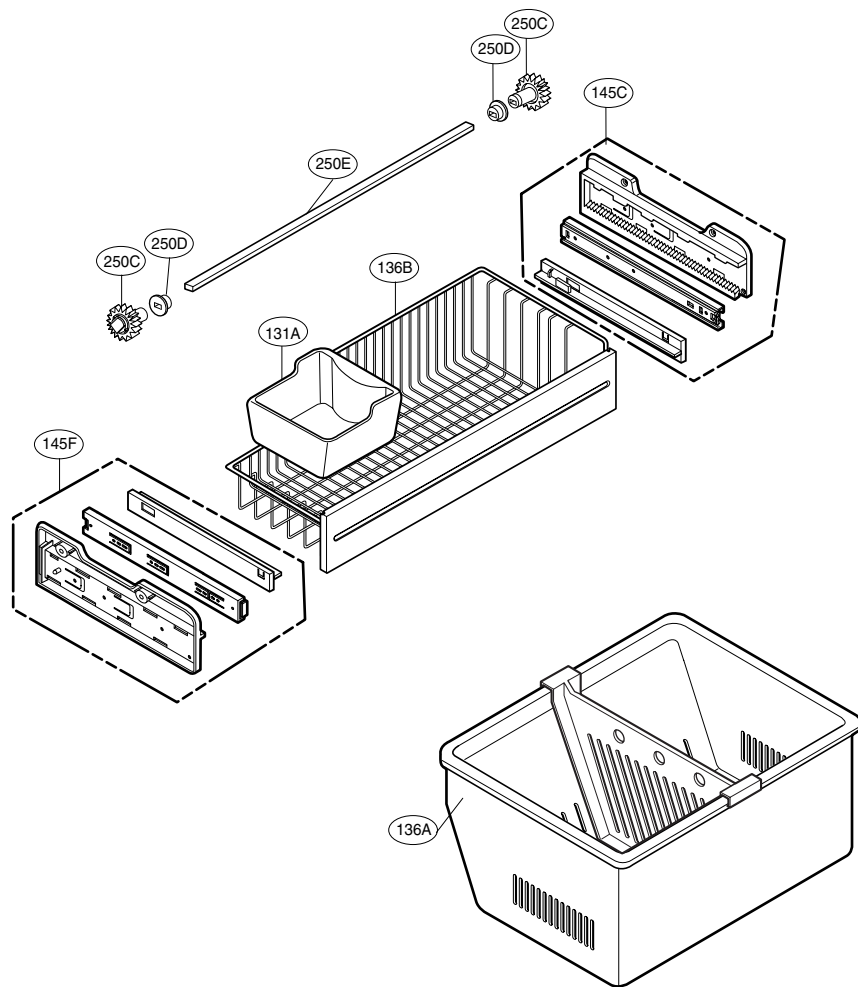

# REFRIGERATOR PARTS

CAUTION: Use the part number to order part, not the position number.

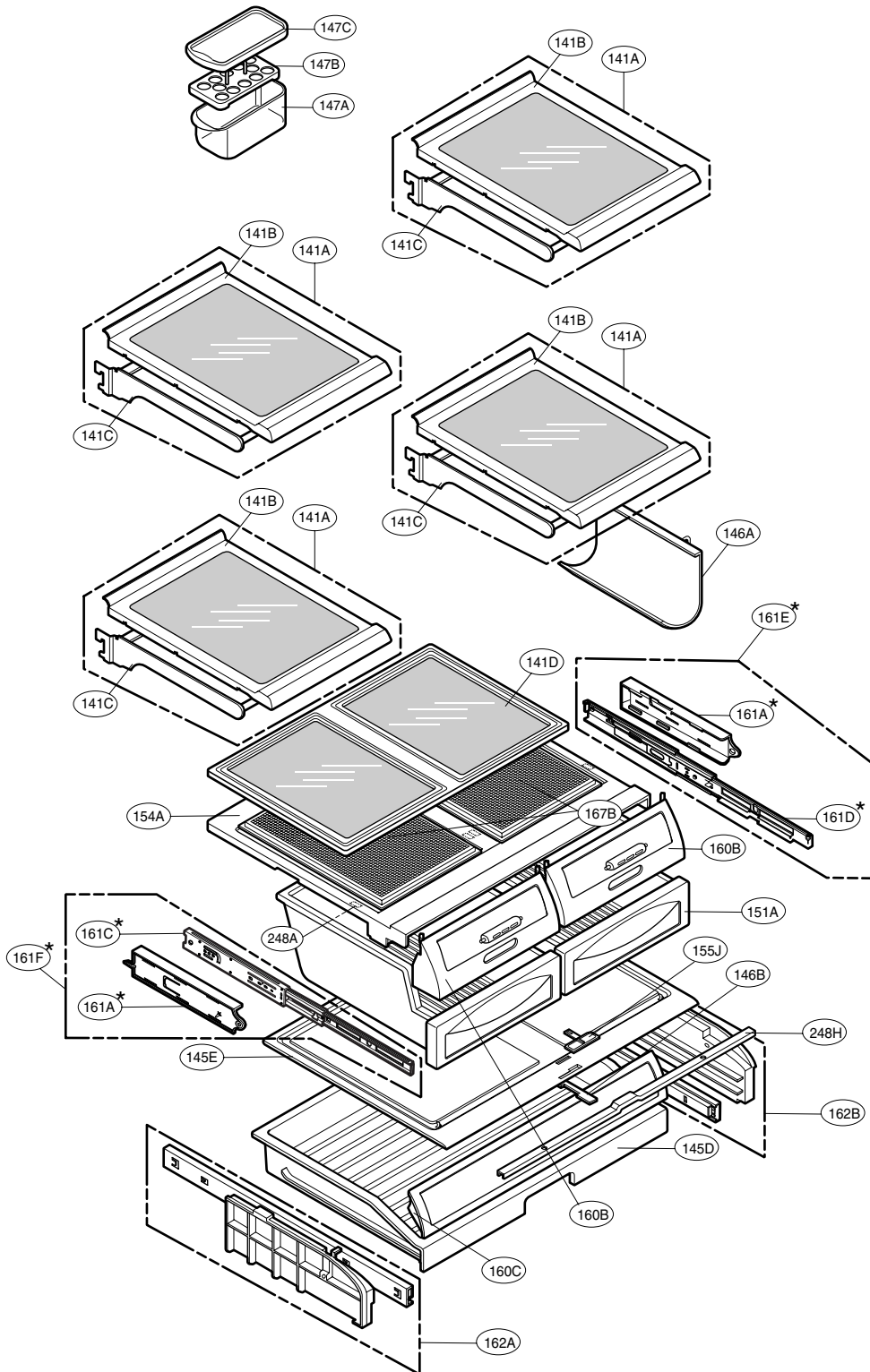

\* : on some models

# DOOR PARTS

CAUTION: Use the part number to order part, not the position number.

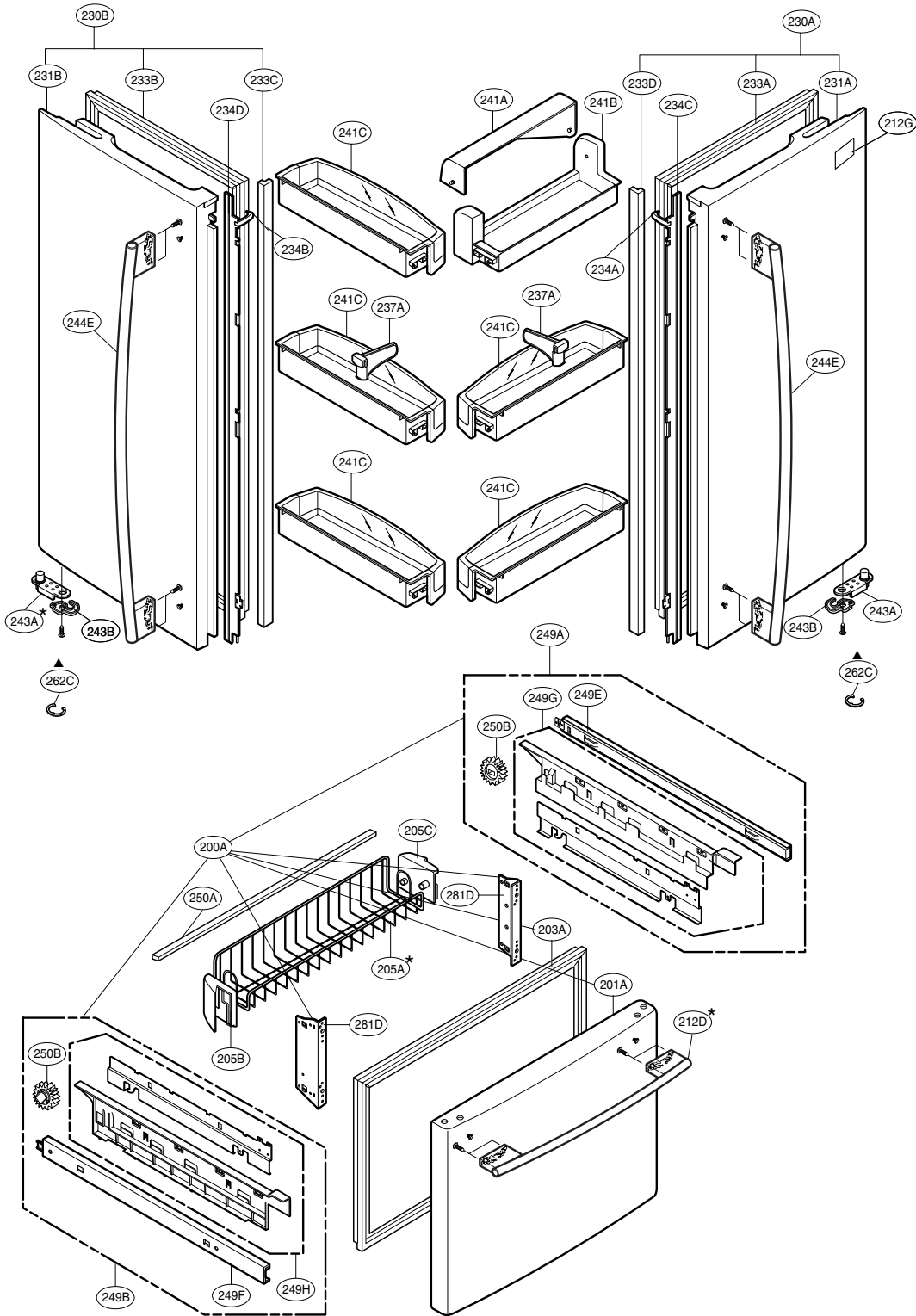

\* : on some models  
 ▲ Only for the service

# WATER AND ICEMAKER PARTS

CAUTION: Use the part number to order part, not the position number.

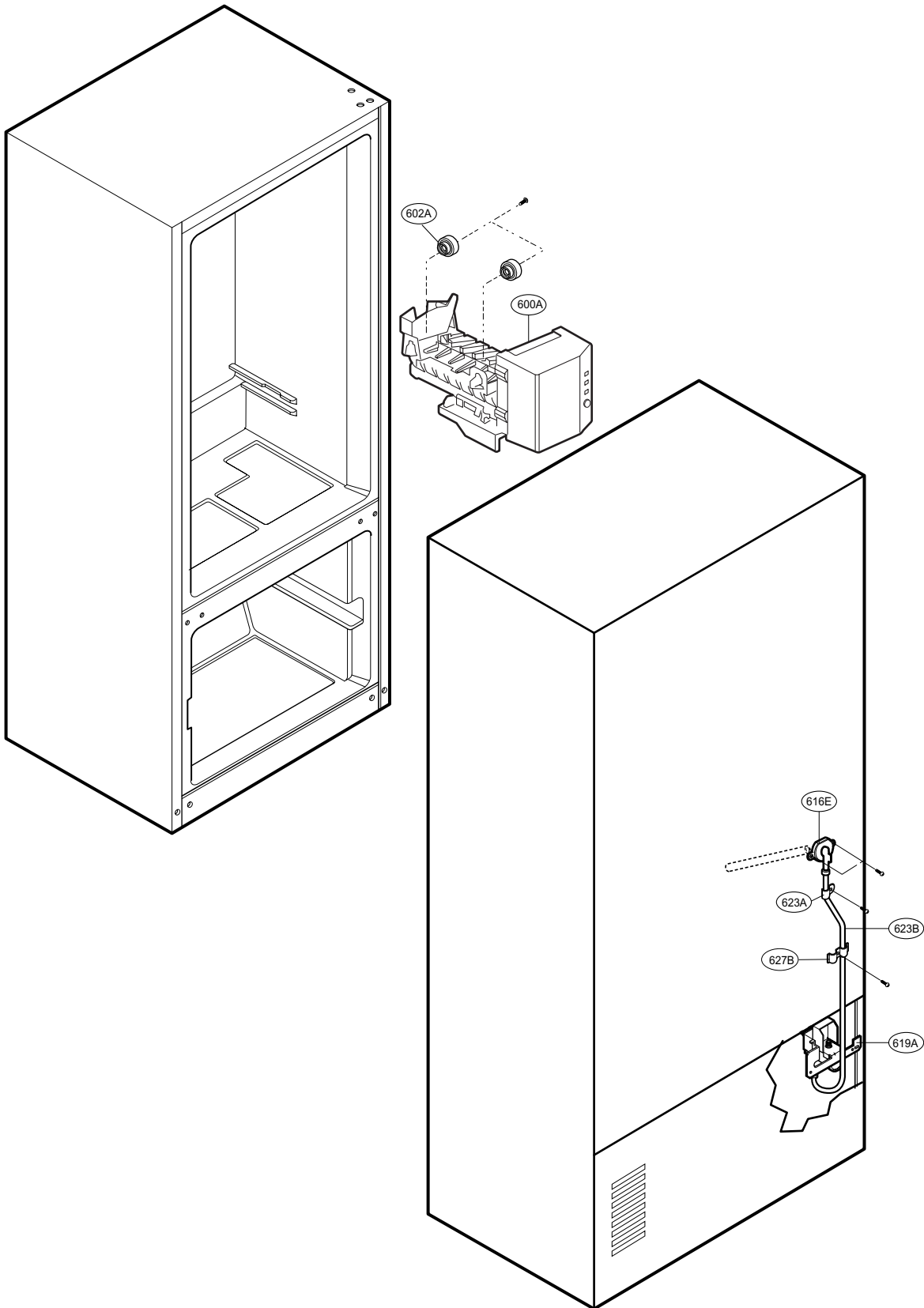



P/No. 3828JD8990C

MAR., 2006 Printed in Korea