

This Owner's Manual is provided and hosted by [Appliance Factory Parts](#).



# LG LFX23961SW Owner's Manual

[Shop genuine replacement parts for LG LFX23961SW](#)



[Find Your LG Refrigerator Parts - Select From 834 Models](#)

----- Manual continues below -----



**LG**

# REFRIGERATOR

# SERVICE MANUAL

**CAUTION**  
BEFORE SERVICING THE UNIT,  
READ THE SAFETY PRECAUTIONS IN THIS MANUAL.

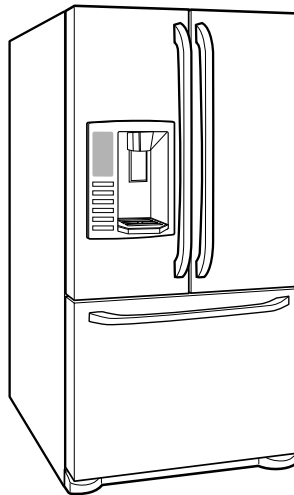

MODELS:

LFX23961\*\*

# CONTENTS

---

|   |    |
|---|----|
| <b>SAFETY PRECAUTIONS</b> .....                                   | 2  |
| <b>1. SPECIFICATIONS</b> .....                                    | 3  |
| <b>2. PARTS IDENTIFICATION</b> .....                              | 4  |
| <b>3. DISASSEMBLY</b> .....                                       | 5  |
| 3.1 Door .....  | 5  |
| 3.2 Door alignment .....  | 7  |
| 3.3 Fan and fan motor .....                                       | 7  |
| 3.4 Defrost control assembly .....                                | 8  |
| 3.5 Lamp .....  | 8  |
| 3.6 Multi duct .....  | 9  |
| 3.7 Main PWB.....   | 9  |
| 3.8 Display PCB.....  | 9  |
| 3.9 Ice button assembly .....                                     | 9  |
| 3.10 Funnel replacement .....                                     | 9  |
| 3.11 Water button assembly .....                                  | 10 |
| 3.12 Duct door replacement.....                                   | 10 |
| 3.13 Ice corner door replacement .....                            | 10 |
| 3.14 Icemaker assembly .....                                      | 10 |
| 3.15 Auger motor cover .....                                      | 11 |
| 3.16 How to remove a door ice bin .....                           | 12 |
| 3.17 How to insert a door ice bin .....                           | 12 |
| 3.18 How to remove and reinstall the pullout drawer .....         | 13 |
| 3.19 Fan and fan motor disassembly .....                          | 15 |
| 3.20 Pull out drawer .....  | 15 |
| <b>4. ADJUSTMENT</b> .....  | 16 |
| 4.1 Compressor .....  | 16 |
| 4.2 PTC-Starter .....   | 16 |
| 4.3 OLP (Overload Protector) .....                                | 17 |
| 4.4 To remove the cover PTC .....                                 | 17 |
| <b>5. CIRCUIT DIAGRAM</b> .....                                   | 18 |
| <b>6. TROUBLESHOOTING</b> .....                                   | 19 |
| 6.1 Compressor and electrical components .....                    | 19 |
| 6.2 Other electrical components .....                             | 20 |
| 6.3 Service diagnosis chart .....                                 | 21 |
| 6.4 Refrigeration cycle .....                                     | 22 |
| <b>7. OPERATION PRINCIPLE AND REPAIR METHOD OF ICEMAKER</b> ..... | 24 |
| 7.1 Operation principle .....                                     | 24 |
| 7.2 Ice maker functions .....                                     | 25 |
| 7.3 Defect diagnosis function .....                               | 26 |
| <b>8. DESCRIPTION OF FUNCTION &amp; CIRCUIT OF MICOM</b> .....    | 27 |
| 8.1 Function .....  | 27 |
| 8.2 PCB function .....  | 33 |
| 8.3 Troubleshooting .....   | 38 |
| 8.4 Main PWB assembly and parts list .....                        | 40 |
| <b>9. EXPLODED VIEW AND REPLACEMENT PART LIST</b> .....           | 43 |

## SAFETY PRECAUTIONS

---

Please read the following instructions before servicing your refrigerator.

1. Unplug the power before handling any electrical components.
2. Check the rated current, voltage, and capacity.
3. Take caution not to get water near any electrical components.
4. Use exact replacement parts.
5. Remove any objects from the top prior to tilting the product.

# 1. SPECIFICATIONS

| ITEMS               | SPECIFICATIONS                           | ITEMS             | SPECIFICATIONS     |                |
|---------------------|--|-------------------|--------------------|----------------|
| DOOR DESIGN         | Side Rounded                             | VEGETABLE TRAY    | Opaque Drawer Type |                |
| DIMENSIONS (inches) | 35 3/4 x 30 x 69 3/4 (WxDxH) 21cu.ft     | COMPRESSOR        | Recipro            |                |
|                     | 35 3/4 x 34 1/4 x 69 3/4 (WxDxH) 25cu.ft | EVAPORATOR        | Fin Tube Type      |                |
| NET WEIGHT (pounds) | 302.58 (21cu.ft)                         | CONDENSER         | Wire Condenser     |                |
|                     | 324.18 (25cu.ft)                         | REFRIGERANT       | R-134a (120 g)     |                |
| COOLING SYSTEM      | Fan Cooling                              | LUBRICATING OIL   | ISO7 (310 ml)      |                |
| TEMPERATURE CONTROL | Micom Control                            | DEFROSTING DEVICE | SHEATH HEATER      |                |
| DEFROSTING SYSTEM   | Full Automatic                           | LAMP              | REFRIGERATOR       | LED Module(12) |
|                     | Heater Defrost                           |                   | FREEZER            | LED Module(3)  |
| DOOR FINISH         | Embossed Metal, VCM, Stainless           |                   |                    |                |
| HANDLE TYPE         | Bar                                      |                   |                    |                |
| INNER CASE          | ABS Resin                                |                   |                    |                |
| INSULATION          | Polyurethane Foam                        |                   |                    |                |

## DIMENSIONS

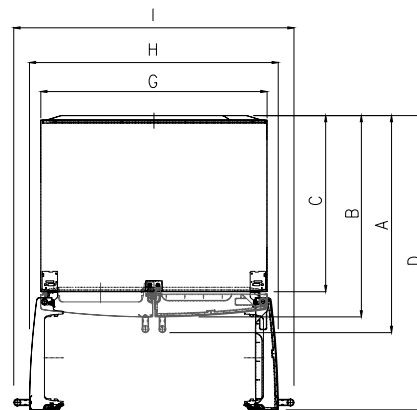
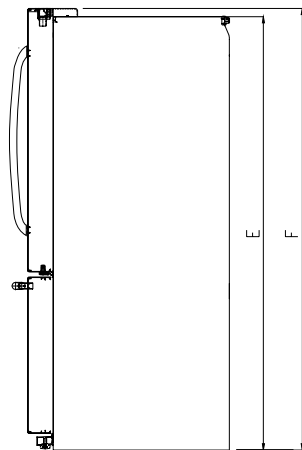

| Description                          |   | LFX21980ST | LFX25980ST |
|--------------------------------------|---|------------|------------|
| Depth w/ Handles                     | A | 30 in.     | 34 1/4 in. |
| Depth w/o Handles                    | B | 27 1/2 in. | 31 3/4 in. |
| Depth w/o Door                       | C | 23 5/8 in. | 27 7/8 in. |
| Depth (Total with Door Open)         | D | 42 1/4 in. | 46 1/2 in. |
| Height to Top of Case                | E | 68 3/8 in. | 68 3/8 in. |
| Height to Top of Door Hinge          | F | 69 3/4 in. | 69 3/4 in. |
| Width                                | G | 35 3/4 in. | 35 3/4 in. |
| Width (door open 90 deg. w/o handle) | H | 39 1/4 in. | 39 1/4 in. |
| Width (door open 90 deg. w/ handle)  | I | 44 1/4 in. | 44 1/4 in. |

## 2. PARTS IDENTIFICATION

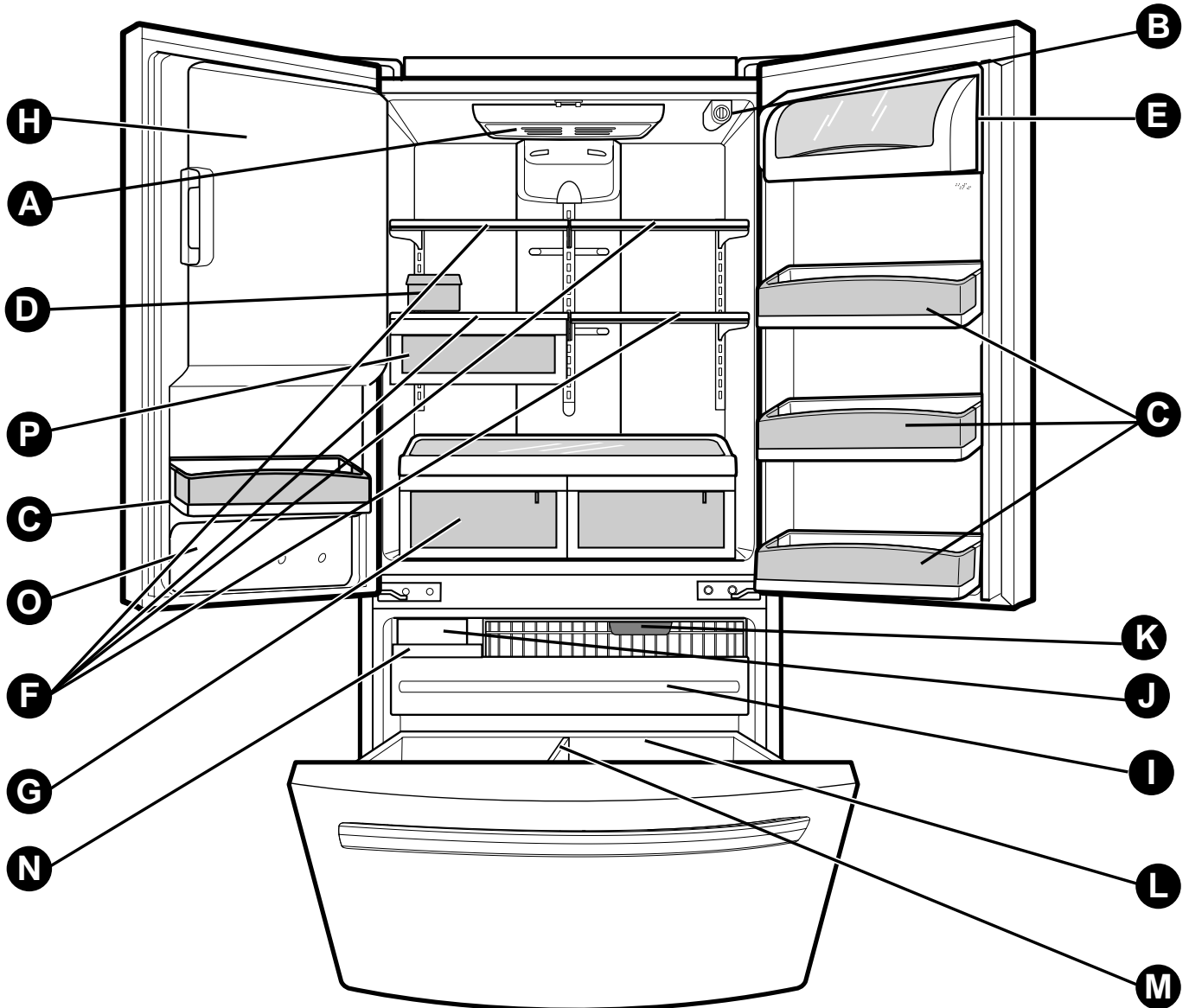

Use this page to become more familiar with the parts and features. Page references are included for your convenience.

**NOTE:** This guide covers several different models. The refrigerator you have purchased may have some or all of the items listed below. The locations of the features shown below may not match your model.

- |                               |                           |
|-------------------------------|---------------------------|
| <b>A</b> Refrigerator Light   | <b>J</b> Turbo Motor      |
| <b>B</b> Filter (Inside)      | <b>K</b> Freezer light    |
| <b>C</b> Modular Door Bins    | <b>L</b> Durabase         |
| <b>D</b> Egg box              | <b>M</b> Divider          |
| <b>E</b> Dairy Bin            | <b>N</b> Ice Bin          |
| <b>F</b> Refrigerator Shelves | <b>O</b> Water Tank Cover |
| <b>G</b> Crisper              | <b>P</b> Snack Pan        |
| <b>H</b> Ice Room             |                           |
| <b>I</b> Glide out Drawer     |                           |

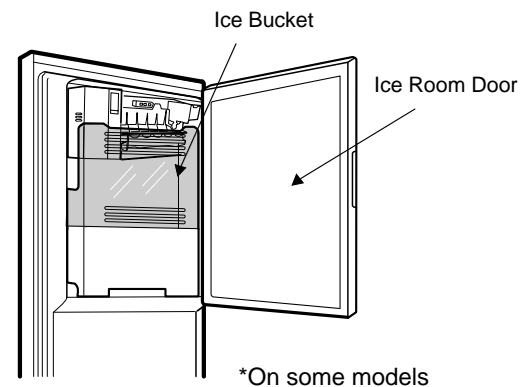

# 3. DISASSEMBLY

## 3-1 DOORS

### 1. Removing Refrigerator Door

**NOTE:** Handle appearance may vary.

**IMPORTANT:** Before you begin, turn the refrigerator OFF and unplug it. Remove food and any bins from doors.

#### ► Left Door

- Loosen the screws and remove the cove on back side (see figure A).
- Disconnect water supply tube by pushing back on the disconnect ring (3).
- Loosen the cover screw (1).
- Disconnect door switch wire (2).
- Pull out the tube (4).

**⚠ CAUTION:** If a tube end is deformed or worn out, cut the damaged portion away.

- Disconnect wire harness (5).
- Remove the ground screw (6).
- Loosen screws (7) and lift off the top hinge (8).
- Place the door on a non-scratching surface with the inside up.

**⚠ CAUTION:** When removing top hinge, be careful that the door does not fall forward.

#### ► Right Door

- Loosen the cover screw (1).
- Disconnect door switch wire (2).
- Loosen screws (7) and lift off the top hinge (8).
- Place the door on a non-scratching surface with the inside up.

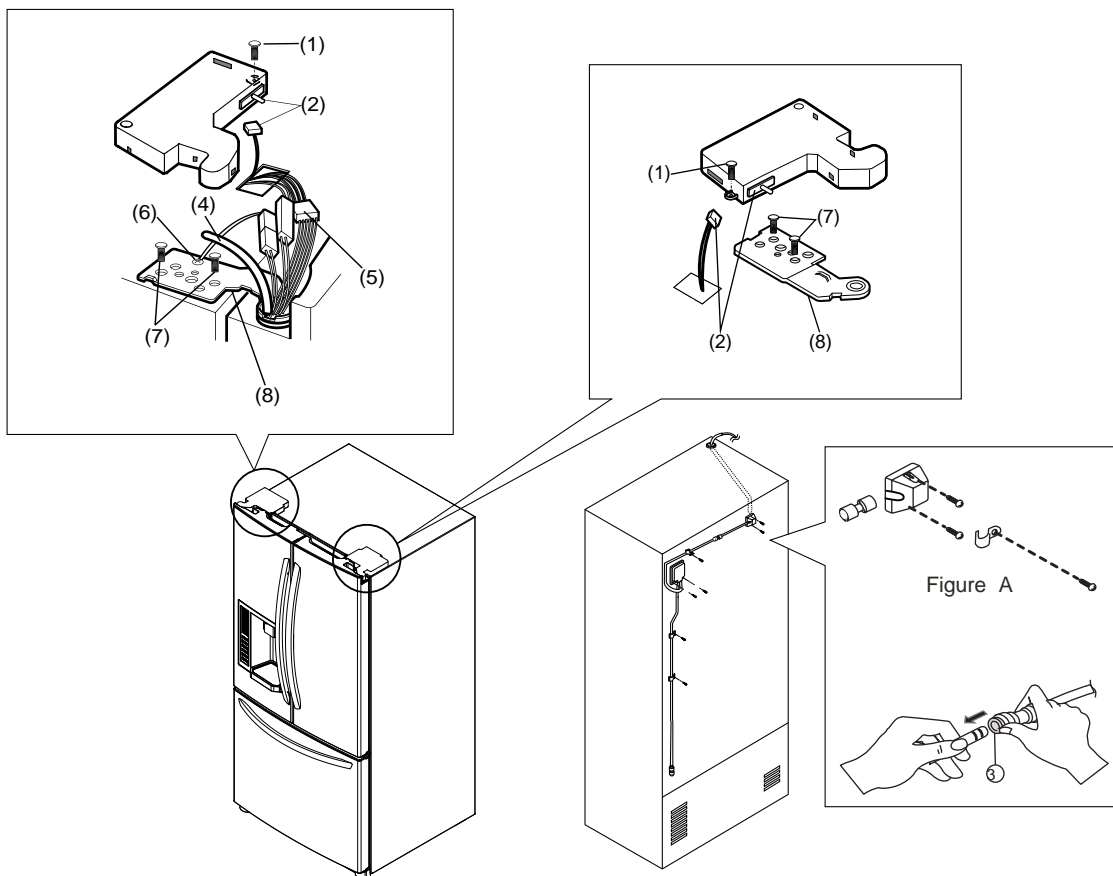

## Door Gasket Removal

### 1. Remove door frame cover

Starting at top of cover and working down, snap cover out and away from door.

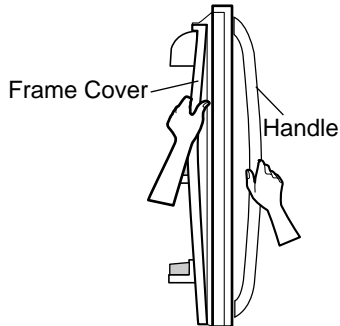

Figure 1

### 2. Remove gasket bracket clips

There are two clips on each door. Start bracket removal near one of the middle clips.

- 1) Pull gasket back to expose gasket bracket clip and door frame.
- 2) Insert a flat tip screwdriver into seam between gasket bracket and door frame and pry back until clips snap out.
- 3) Continue prying back along seam until all clips snap out.

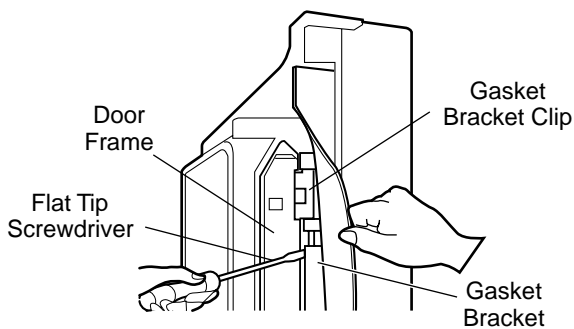

Figure 2

### 3. Remove gasket

Pull gasket free from gasket channel on the three remaining sides of door.

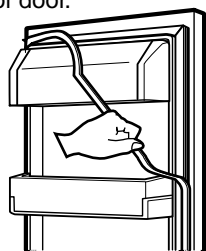

Figure 3

## Door Gasket Replacement

### 1. Insert gasket bracket clips

- 1) Insert gasket bracket edge beneath door frame edge.
- 2) Turn upper gasket bracket spring so that the spring ends are in the door channel.
- 3) Push in clip until you hear it snap securely into place.

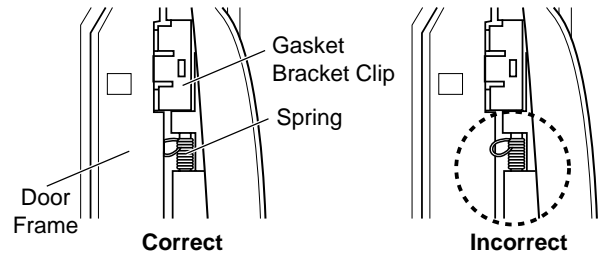

Figure 4

- 4) Push in remaining clip until you hear it snap securely into place.

**Note:** Make sure that no part of gasket bracket edge protrudes from beneath door frame edge.

### 2. Insert gasket into channel

- 1) Snap gasket assembly into the door bracket.

**<Inserting the Gasket Assembly into the Bracket Door>**

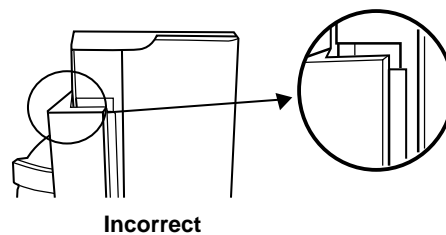
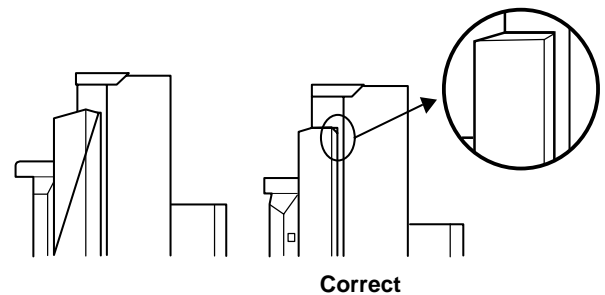

Figure 5

2) Press gasket into channels on the three remaining sides of door.

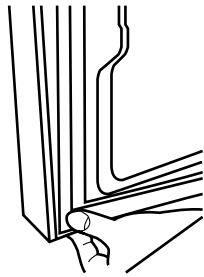

Figure 6

**3. Replace door frame cover**

Starting at top of cover and working down, snap cover back into door.

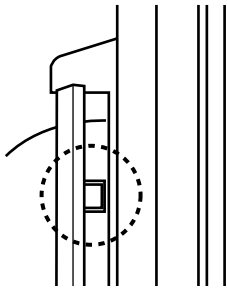

Figure 7

**3-2 DOOR ALIGNMENT**

If fridge door are uneven,

- Use the wrench (Included with the User Manual) to adjust the bolt in the door hinge to adjust the height.(CCW to raise or CW to lower the height.)

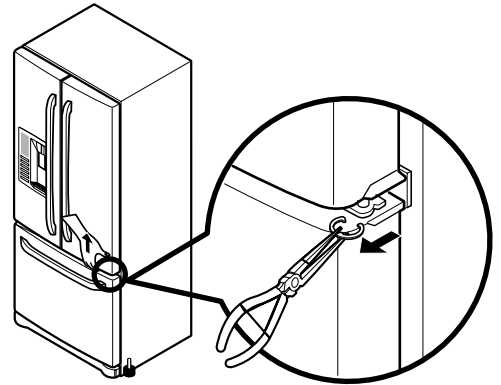

Figure 8

**3-3 FAN AND FAN MOTOR(EVAPORATOR)**

1. Remove the freezer shelf. (If your refrigerator has an icemaker, remove the icemaker first)
2. Remove the plastic guide for slides on left side by unscrewing phillips head screws.
3. Remove the grille by pulling the grille fan forward.
4. Remove the Fan Motor assembly by loosening 2 screws and disassembling the shroud.
5. Pull out the fan and separate the Fan Motor and Bracket.

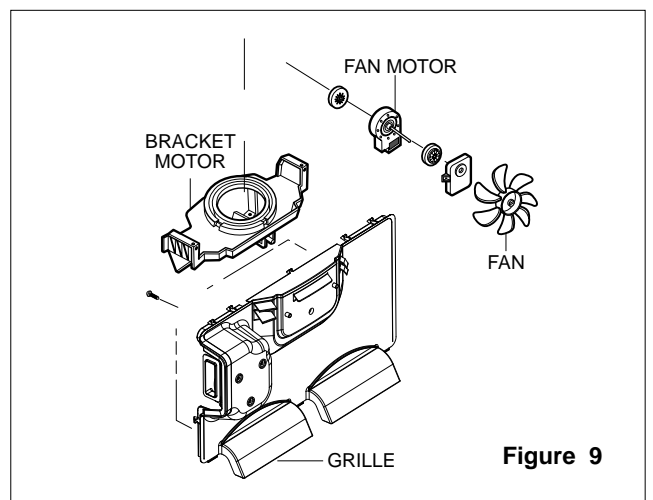

Figure 9

\* Ice Fan Scroll Assembly Replacement

- 1) Remove the plastic guide for slides on left side by unscrewing phillips head screws.
- 2) Pull the grille forward as shown in the second picture.
- 3) Disconnect wire harness of the grille
- 4) Remove the scroll assembly by loosening 3 screws



(1)



(2)



(3)



(4)

**3-4 DEFROST CONTROL ASSEMBLY**

Defrost Control assembly consists of Defrost Sensor and

**FUSE—M.**

The Defrost Sensor works to defrost automatically. It is attached to the metal side of the Evaporator and senses its temperature. At 72°C, it turns the Defrost Heater off.

Fuse-M is a safety device for preventing over-heating of the Heater when defrosting.

1. Pull out the grille assembly. (Figure 10)
2. Separate the connector with the Defrost Control assembly and replace the Defrost Control assembly

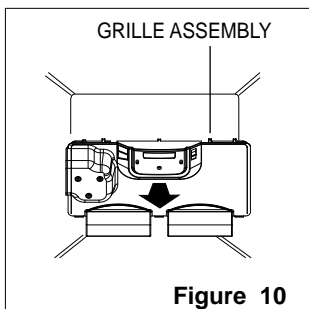

Figure 10

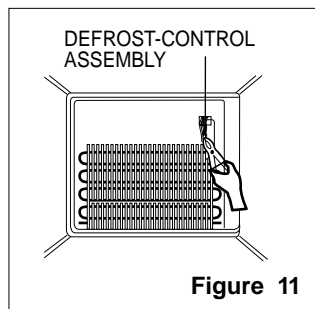

Figure 11

**3-5 LAMP**

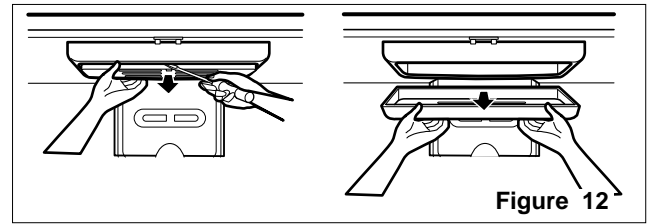

Figure 12

**3-5-1 Refrigerator Compartment Lamp**

1. Unplug Refrigerator, or disconnect power at the circuit breaker.
2. If necessary, remove top shelf or shelves.
3. Using a flat instrument, gently pry the cover loose in the front as shown. Rotate downward to remove rear tabs.
4. Make sure the bulbs are cool to the touch. Turn bulbs counterclockwise to remove.
5. Assemble in reverse order by snapping the Lamp Cover in, engaging the rear tabs followed by the front tabs. (Max. 40 W-2EA)

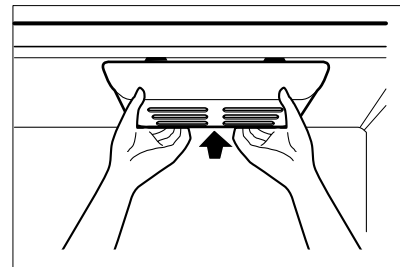

Figure 13

**3-5-2 Freezer Compartment Lamp**

1. Unplug refrigerator power cord from outlet.
2. Gently pry the lamp cover loose in the back as shown. Rotate forward to remove the front tabs.
3. Make sure the bulb is cool to the touch. Turn the bulb counterclockwise to remove.
4. Replace with a new 40-watt appliance bulb.
5. Insert tabs on front of cover into slots in freezer ceiling. Push cover up to snap back into place.

### 3-6 MULTI DUCT

1. Remove the upper and lower Caps by using a flat screwdriver, and remove 2 screws. (Figure 16)
2. Disconnect the lead wire on the bottom position.

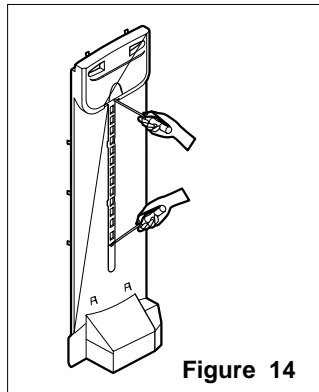

### 3-7 MAIN PWB

- 1) Loosen the 3 screws on the PWB cover.



- 2) Remove the PWB cover



- 3) Disconnect wire harness and replace the main PWB in



- 1) Pull out the darin



- 2) Grasp the lower part of the dispenser firmly ,pull it out.



- 3) Hold the inner side of cover dispenser with both hands at the handle side to pull it out forward.



- 4) If nozzle is interfered with button , push and pull out the bottom of button.

- 5) Remove the connected part of Lead wire.

**⚠ CAUTION:** When replacing the dispenser cover in the reverse order of removal, be careful that the lead wire does not come out and the water tube is not pinched by the dispenser,



### 3-8 DISPLAY PCB

As shown below, remove 1 case PCB fixing screw.  
Remove the display PCB fixing screw.



Case, PCB



Display PCB

### 3-9 ICE BUTTON ASSEMBLY

- 1) Remove the screw fixing the button lever.
- 2) Push the spring from the hanging hook to remove it.
- 3) Apply some pressure to the rib in direction and lift the button in Direction.



Button Lever



### 3-10 FUNNEL REPLACEMENT

Pull down and forward.



### 3-11 WATER BUTTON ASSMEBLY

- 1) Romove screws.
- 2) Grasp the Button assembly and lift up.

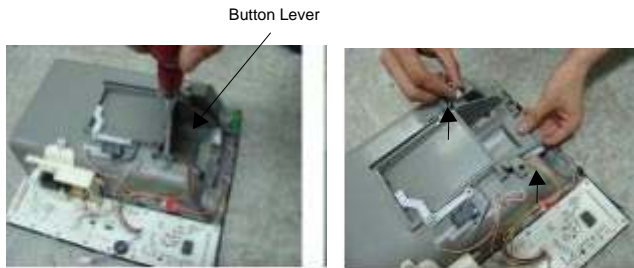

### 3-12 DUCT DOOR REPLACEMENT

- 1) Pull up and out on the dispenser cover to remove.
- 2) Disconnect the wire harness.
- 3) Remove the funnel
- 4) Replace in reverse order.



### 3-13 ICE CORNER DOOR REPLACEMENT

- 1) Loosen the front screw as shown in the picture.
- 2) Lift up the hinge with one hand.
- 3) Pull out the Ice Corner Door with the other hand.



### 3-14 ICEMAKER ASSEMBLY

- 1) Loosen two screws as shown in the first picture.



- 2) Disconnect the wire harness & ground screw replace the icemaker assembly in the reverse order of removal.



- 3) It separates a ground connection screw.



---

### 3-15 AUGER MOTOR COVER

1) After removing the icemaker remove the (5) stainless screws holding the auger motor cover, shown in the pictures below.



2) Grip the bottom of motor cover assembly and pull out it.



3) Disconnect wire harness of motor cover assembly. There is a auger motor on the back, as shown in the picture.



Auger Motor

### 3-16 HOW TO REMOVE A DOOR ICE BIN

1) Grip the handles, as shown in the picture.

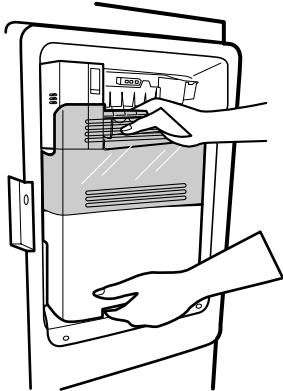

2) Lift the lower part slightly.

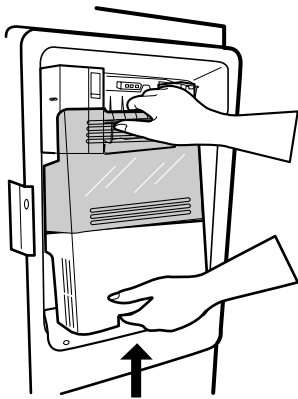

3) Take the Ice Bin out slowly.

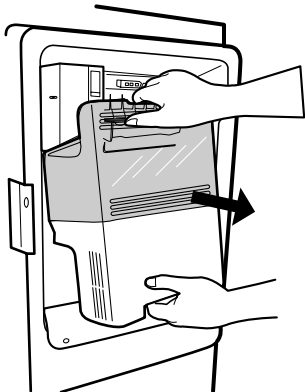

### 3-17 HOW TO INSERT A DOOR ICE BIN

1) Insert the Ice Bin, slightly tilting it to avoid touching the Icemaker. (especially, ice maker lever)

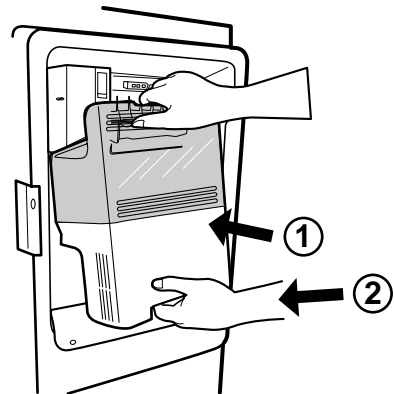

※ Insert the ice bucket carefully avoid contacting the automatic shut off arm.

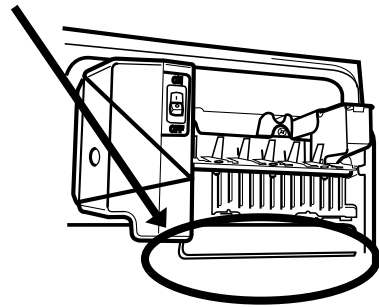

---

### 3-18 HOW TO REMOVE AND REINSTALL THE PULLOUT DRAWER

#### 3-19-1 Follow Steps to Remove

Step 1) Open the freezer door.



Step 2) Remove the lower basket.



Step 3) Remove the two screws from the guide rails (one from each side).



Step 4) Lift the freezer door up to unhook it from the rail support and remove. Pull both rails to full extension.



Step 5) First: Remove the gear from the left side first by releasing the tab behind the gear, place a screwdriver between the gear and the tab and pull up on the gear.

Second: Remove the center rail.

Third: Remove the gear from the right side by following the same steps for the left side.

**NOTE: THIS TAB MUST BE PUSHED IN TO RELEASE THE GEAR.**

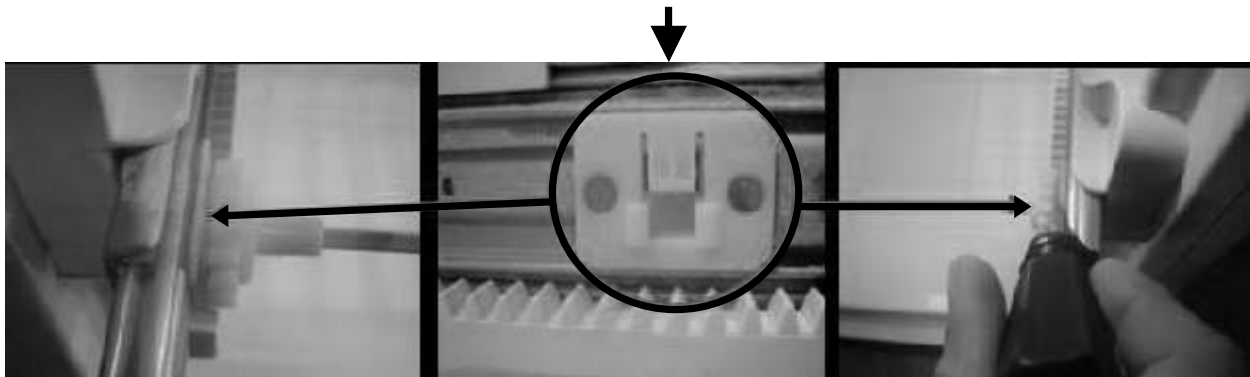

---

### 3-18-2 Follow Steps to Reinstall

Step 1) Reinstall the right side gear into the clip.



Step 2) Insert the rail into the right side gear. Gears do **not** need to be perpendicular to each other.



Step 3) Insert the rail into the left side gear, and insert the gear into the clip.



Step 4) The rail system will align itself by pushing the rails all the way into the freezer section. Pull the rails back out to full extension.

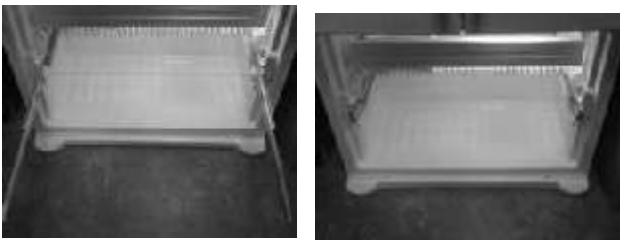

Step 5) Reinstall the freezer door by inserting the rail tabs into the guide rail.



Step 6) Reinstall the two screws into the guide rails (one from each side).



Step 7) Reinstall the lower basket, and close the freezer door.



### 3-19 FAN AND FAN MOTOR DISASSEMBLY METHOD

1) Using a short screwdriver, loosen one SCREW in DRAIN PIPE ASSEMBLY and one connected to the MOTOR COVER.

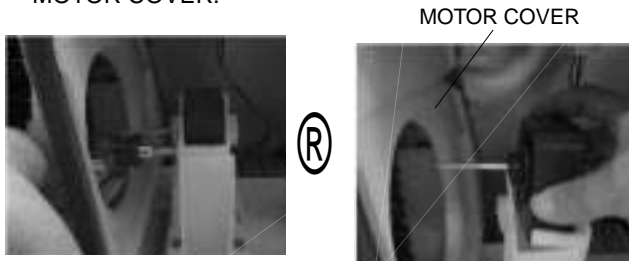

2) Pull and separate the FAN ASSEMBLY and MOTOR turning counterclockwise based on the MOTOR SHAFT.

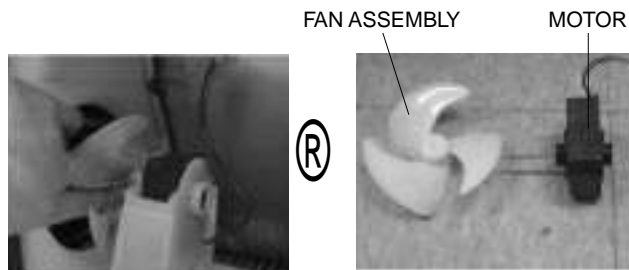

The assembly is in the reverse order of the disassembly and take special care for the following details.

1. Be careful not to bend the tube during assembly.
2. Press the WATER DISPENSER button until water pours out and check for leakage in the CONNECTOR TUBE (It differs by the water pressure but usually takes about 2 minutes until water pours out.)

### 3-20 PULL OUT DRAWER

1. To remove, lift basket up and pull out straight out.

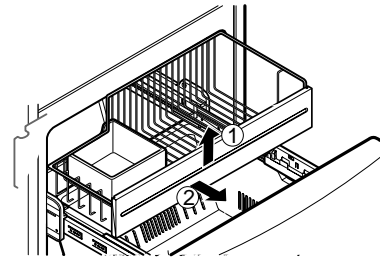

2. To Install, pull both rails out to full extension. Hook the basket supports into the rail tabs and push to the back of compartment.

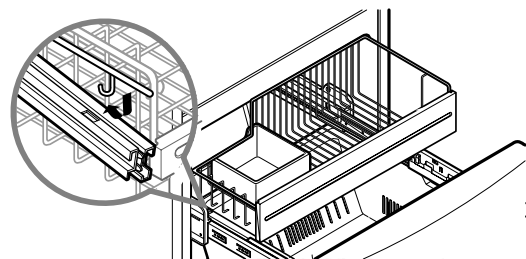
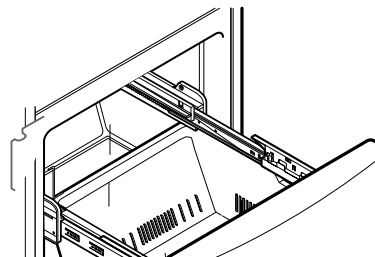

# 4. ADJUSTMENT

## 4-1 COMPRESSOR

### 4-1-1 Role

The compressor intakes low temperature and low pressure gas from the evaporator of the refrigerator and compresses this gas to high-temperature and high-pressure gas. It then delivers the gas to the condenser.

### 4-1-2 Composition

The compressor includes overload protection. The PTC starter and OLP (overload protector) are attached to the outside of the compressor. Since the compressor is manufactured to tolerances of 1 micron and is hermetically sealed in a dust and moisture-free environment, use extreme caution when performing repairs.

### 4-1-3 Note for Usage

- (1) Be careful not to allow over-voltage and over-current.
- (2) If compressor is dropped or handled carelessly, poor operation and noise may result.
- (3) Use proper electric components appropriate to the Particular Compressor in your product.
- (4) Keep Compressor dry.  
If the Compressor gets wet (in the rain or a damp environment) and rust forms in the pin of the Hermetic Terminal, poor operation and contact may result.
- (5) When replacing the Compressor, be careful that dust, humidity, and soldering flux don't contaminate the inside of the compressor. Dust, humidity, and solder flux contaminate the cylinder and may cause noise, improper operation or even cause it to lock up.

## 4-2 PTC-STARTER

### 4-2-1 Composition of PTC-Starter

- (1) PTC (Positive Temperature Coefficient) is a no-contact semiconductor starting device which uses ceramic material consisting of BaTiO<sub>3</sub>.
- (2) The higher the temperature is, the higher the resistance value. These features are used as a starting device for the Motor.

### 4-2-2 Role of PTC-Starter

- (1) The PTC is attached to the Sealed Compressor and is used for starting the Compressor Motor.
- (2) The compressor is a single-phase induction motor. The starting operation, the PTC allows current flow to both the start winding and main winding.

## 4-2-3 PTC-Applied Circuit Diagram

### Starting Method for the Motor

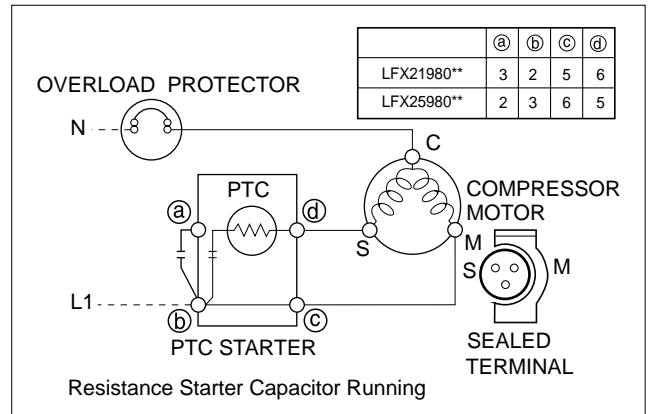

### 4-2-4 Motor Restarting and PTC Cooling

- (1) It requires approximately 5 minutes for the pressure to equalize before the compressor can restart.
- (2) The PTC device generates heat during operation. Therefore, it must be allowed to cool before the compressor can restart.

### 4-2-5 Relation of PTC-Starter and OLP

- (1) If the compressor attempts to restart before the PTC device is cooled, the PTC device will allow current to flow only to the main winding.
- (2) The OLP will open because of the over current condition. This same process will continue (3 to 5 times) when the compressor attempts to restart until the PTC device has cooled. The correct OLP must be properly attached to prevent damage to the compressor.  
Parts may appear physically identical but could have different electrical ratings. Replace parts by part number and model number. Use only approved substitute parts.

### 4-2-6 Note for Using the PTC-Starter

- (1) Be careful not to allow over-voltage and over-current.
- (2) Do not drop or handle carelessly.
- (3) Keep away from any liquid.  
If liquid such as oil or water enters the PTC, PTC materials may fail due to breakdown of their insulating capabilities.
- (4) If the exterior of the PTC is damaged, the resistance value may be altered. This can cause damage to the compressor and result in a no-start or hard-to-start condition.
- (5) Always use the PTC designed for the compressor and make sure it is properly attached to the compressor. Parts may appear physically identical but could have different electrical ratings. Replace parts by part number and model number. Use only approved substitute parts.

### 4-3 OLP (OVERLOAD PROTECTOR)

#### 4-3-1 Definition of OLP

- (1) OLP (OVERLOAD PROTECTOR) is attached to the Compressor and protects the Motor by opening the circuit to the Motor if the temperature rises and activating the bimetal spring in the OLP.
- (2) When high current flows to the Compressor motor, the Bimetal works by heating the heater inside the OLP, and the OLP protects the Motor by cutting off the current flowing to the Compressor Motor.

#### 4-3-2 Role of the OLP

- (1) The OLP is attached to the Sealed Compressor used for the Refrigerator. It prevents the Motor Coil from being started in the Compressor.
- (2) For normal operation of the OLP, do not turn the Adjust Screw of the OLP in any way.

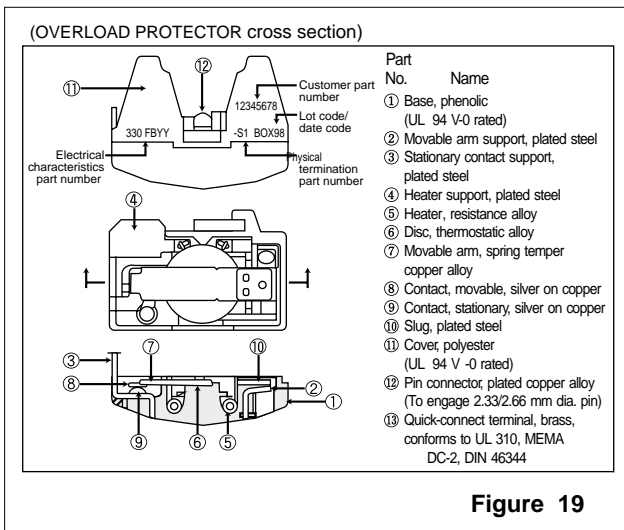
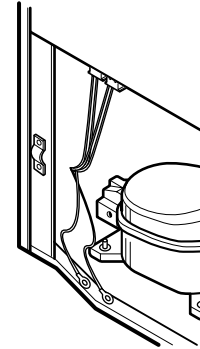
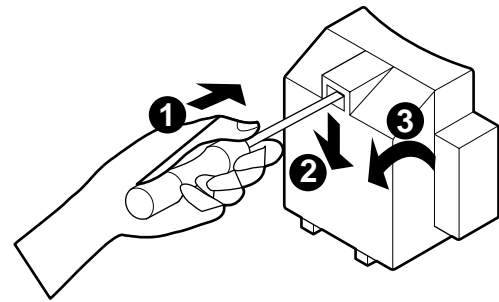

Figure 19

### 4-4 TO REMOVE THE COVER PTC



- (1) Remove the Cover Back M/C.
- (2) Disconnect two housing upper side of comp connected in.
- (3) Loosen two screws on comp base.



- (4) Use a L-shaped flap tool to pry off the cover.
- (5) Assembly in reverse order of disassembly.

# 5. CIRCUIT DIAGRAM

## LG Electronics CIRCUIT DIAGRAM

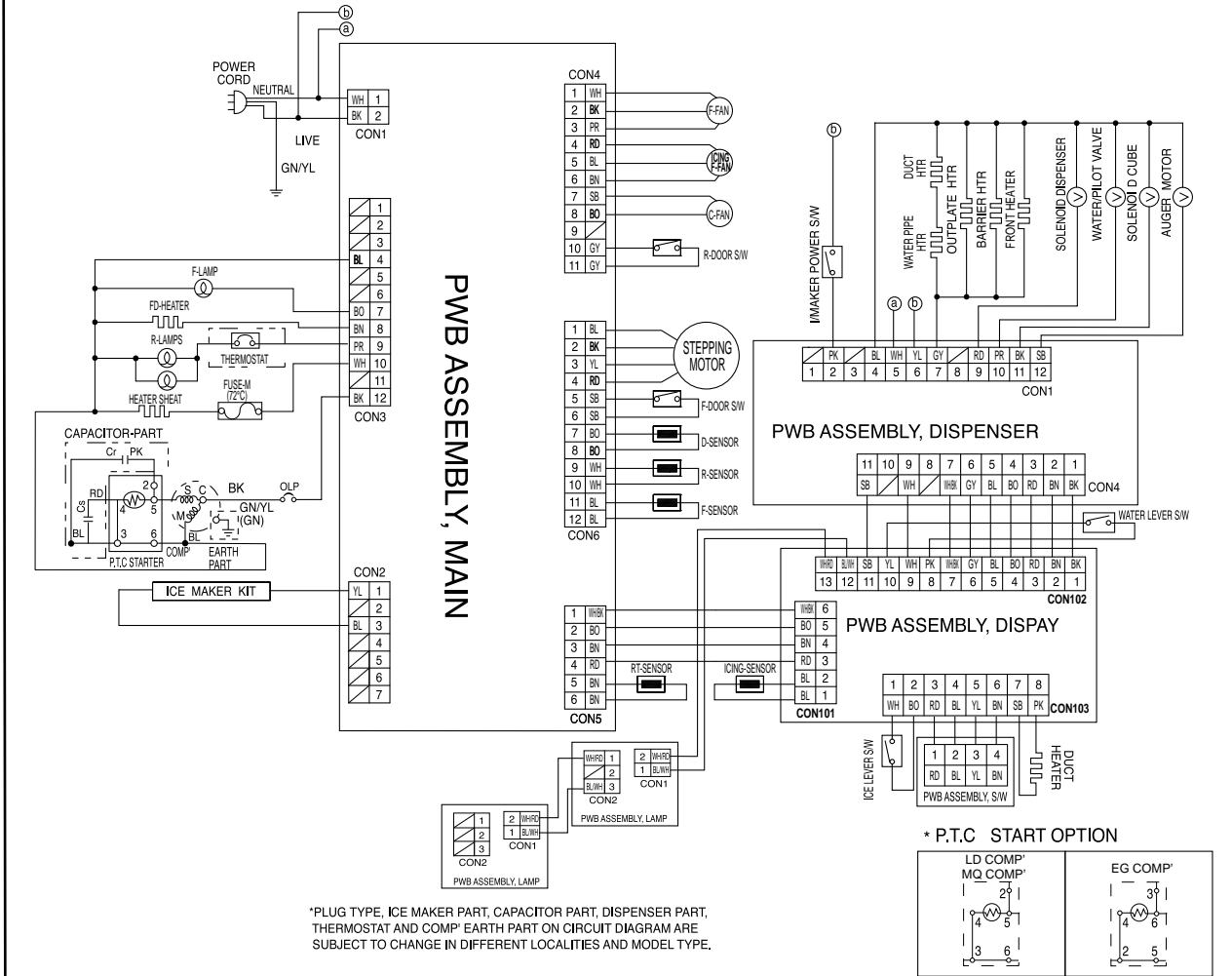

\*PLUG TYPE, ICE MAKER PART, CAPACITOR PART, DISPENSER PART, THERMOSTAT AND COMP' EARTH PART ON CIRCUIT DIAGRAM ARE SUBJECT TO CHANGE IN DIFFERENT LOCALITIES AND MODEL TYPE.

BK : BLACK      BN : BROWN      BO : BRIGHT ORANGE      GY : GRAY      RD : RED  
 YL : YELLOW      GN : GREEN      PR : PURPLE      WH : WHITE      WH/BK : WHITE/BLACK  
 SB : SKY BLUE      PK : PINK      GN/YN : GREEN/YELLOW      BL/WH : BLUE/WHITE      RD/WH : RED/WHITE

# 6. TROUBLESHOOTING

## 6-1 COMPRESSOR AND ELECTRIC COMPONENTS

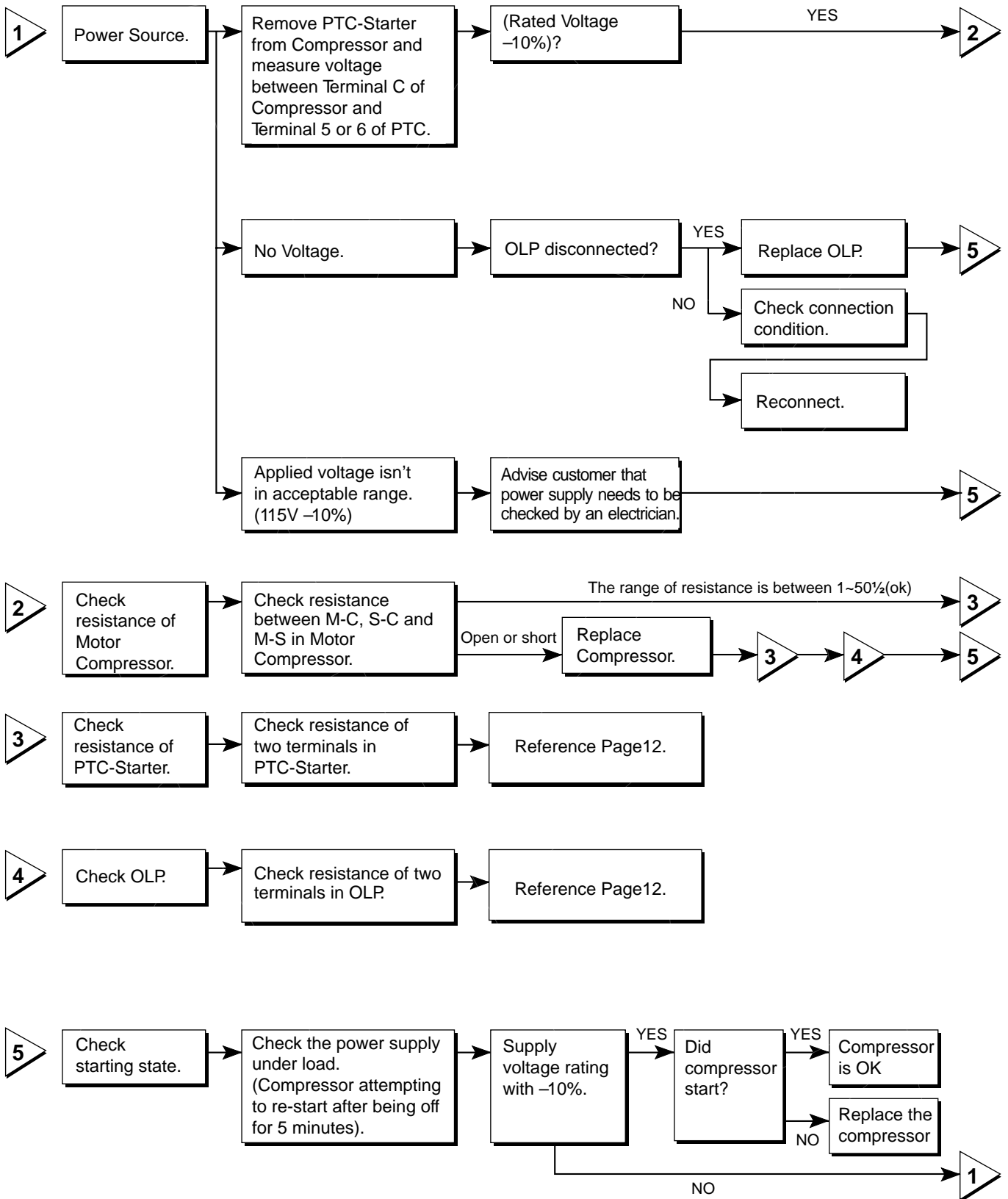

## 6-2 OTHER ELECTRICAL COMPONENTS

### • Not cooling at all

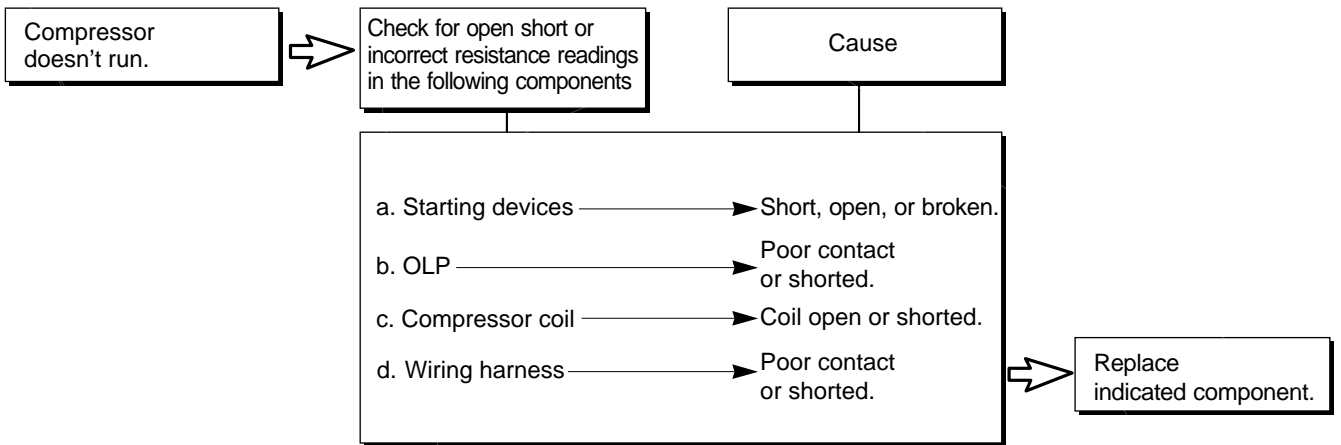

### t Poor cooling performance

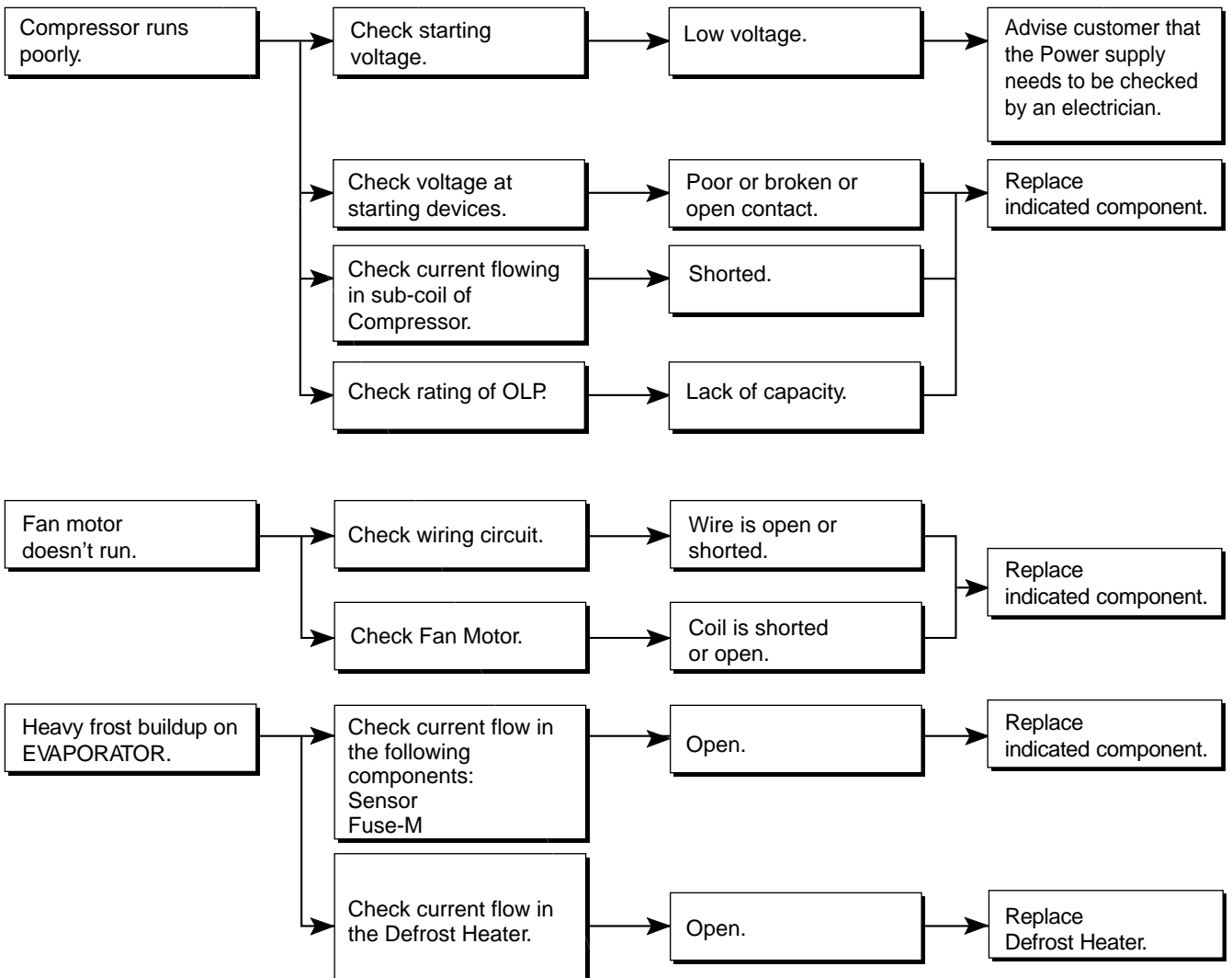

### 6-3 SERVICE DIAGNOSIS CHART

| COMPLAINT                                  | POINTS TO BE CHECKED  | REMEDY   |
|--|---|--|
| No Cooling.                                | <ul style="list-style-type: none"> <li>• Is the power cord unplugged from the outlet?</li> <li>• Check if the power switch is set to OFF.</li> <li>• Check if the fuse of the power switch is shorted.</li> <li>• Measure the voltage of the power outlet.</li> </ul>   | <ul style="list-style-type: none"> <li>• Plug into the outlet.</li> <li>• Set the switch to ON.</li> <li>• Replace the fuse.</li> <li>• If the voltage is low, correct the wiring.</li> </ul>  |
| Cools poorly.                              | <ul style="list-style-type: none"> <li>• Check if the unit is placed too close to the wall.</li> <li>• Check if the unit is placed too close to the stove, gas cooker, or in direct sunlight.</li> <li>• Is the ambient temperature too high or the room door closed?</li> <li>• Check if food put in the refrigerator is hot.</li> <li>• Did you open the door of the unit too often or check if the door is sealed properly?</li> <li>• Check if the Control is set to <b>Warm position</b>.</li> </ul> | <ul style="list-style-type: none"> <li>• Place the unit about 4 inches (10 cm) from the wall.</li> <li>• Place the unit away from these heat sources.</li> <li>• Lower the ambient temperature.</li> <li>• Put in foods after they have cooled down.</li> <li>• Don't open the door too often and close it firmly.</li> <li>• Set the control to <b>Recommended position</b>.</li> </ul> |
| Food in the Refrigerator is frozen.        | <ul style="list-style-type: none"> <li>• Is food placed in the cooling air outlet?</li> <li>• Check if the control is set to <b>colder position</b>.</li> <li>• Is the ambient temperature below 41°F(5°C)?</li> </ul>  | <ul style="list-style-type: none"> <li>• Place foods in the high-temperature section. (front part)</li> <li>• Set the control to <b>Recommended position</b>.</li> <li>• Set the control to <b>Warm position</b>.</li> </ul>   |
| Condensation or ice forms inside the unit. | <ul style="list-style-type: none"> <li>• Is liquid food sealed?</li> <li>• Check if food put in the refrigerator is hot.</li> <li>• Did you open the door of the unit too often or check if the door is sealed properly?</li> </ul>   | <ul style="list-style-type: none"> <li>• Seal liquid foods with wrap.</li> <li>• Put in foods after they have cooled down.</li> <li>• Don't open the door too often and close it firmly.</li> </ul>  |
| Condensation forms in the Exterior Case.   | <ul style="list-style-type: none"> <li>• Check if the ambient temperature and humidity of the surrounding air are high.</li> <li>• Is there a gap in the door gasket?</li> </ul>  | <ul style="list-style-type: none"> <li>• Wipe moisture with a dry cloth. It will disappear in low temperature and humidity.</li> <li>• Fill up the gap.</li> </ul>   |
| There is abnormal noise.                   | <ul style="list-style-type: none"> <li>• Is the unit positioned in a firm and even place?</li> <li>• Are any unnecessary objects placed in the back side of the unit?</li> <li>• Check if the Drip Tray is not firmly fixed.</li> <li>• Check if the cover of the compressor enclosure in the lower front side is taken out.</li> </ul>   | <ul style="list-style-type: none"> <li>• Adjust the Leveling Screw, and position the refrigerator in a firm place.</li> <li>• Remove the objects.</li> <li>• Fix the Drip Tray firmly in the original position.</li> <li>• Place the cover in its original position.</li> </ul>  |
| Door does not close well.                  | <ul style="list-style-type: none"> <li>• Check if the door gasket is dirty with an item like juice.</li> <li>• Is the refrigerator level?</li> <li>• Is there too much food in the refrigerator?</li> </ul>   | <ul style="list-style-type: none"> <li>• Clean the door gasket.</li> <li>• Position in a firm place and level the Leveling Screw.</li> <li>• Make sure food stored in shelves does not prevent the door from closing.</li> </ul>   |
| Ice and foods smell unpleasant.            | <ul style="list-style-type: none"> <li>• Check if the inside of the unit is dirty.</li> <li>• Are foods with a strong odor unwrapped?</li> <li>• The unit smells of plastic.</li> </ul>   | <ul style="list-style-type: none"> <li>• Clean the inside of the unit.</li> <li>• Wrap foods that have a strong odor.</li> <li>• New products smell of plastic, but this will go away after 1-2 weeks.</li> </ul>  |

- Other possible problems:

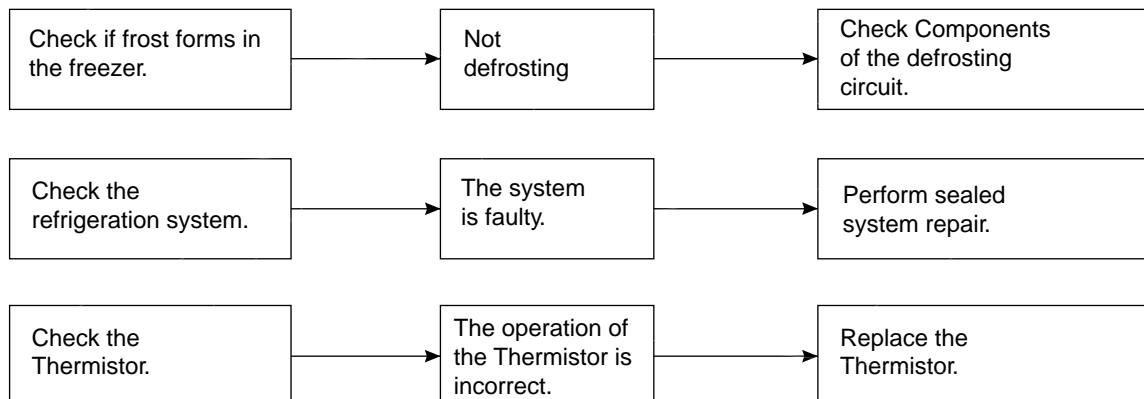

## 6-4 REFRIGERATION CYCLE

- Troubleshooting Chart

| CAUSE                 |                  | STATE OF THE UNIT   | STATE OF THE EVAPORATOR  | TEMPERATURE OF THE COMPRESSOR             | REMARKS   |
|-----------------------|------------------|---|--|---|---|
| LEAKAGE               | PARTIAL LEAKAGE  | Freezer compartment and Refrigerator don't cool normally. | Low flowing sound of Refrigerant is heard and frost forms in inlet only. | A little higher than ambient temperature. | <ul style="list-style-type: none"> <li>• Refrigerant level is low due to a leak.</li> <li>• Normal cooling is possible by restoring the normal amount of refrigerant and repairing the leak.</li> </ul> |
|                       | COMPLETE LEAKAGE | Freezer compartment and Refrigerator don't cool normally. | Flowing sound of refrigerant is not heard and frost isn't formed.        | Equal to ambient temperature.             | <ul style="list-style-type: none"> <li>• No discharging of Refrigerant.</li> <li>• Normal cooling is possible by restoring the normal amount of refrigerant and repairing the leak.</li> </ul>          |
| CLOGGED BY DUST       | PARTIAL CLOG     | Freezer compartment and Refrigerator don't cool normally. | Flowing sound of refrigerant is heard and frost forms in inlet only.     | A little higher than ambient temperature. | <ul style="list-style-type: none"> <li>• Normal discharging of the refrigerant.</li> <li>• The capillary tube is faulty.</li> </ul>   |
|                       | WHOLE CLOG       | Freezer compartment and refrigerator don't cool.          | Flowing sound of refrigerant is not heard and frost isn't Formed.        | Equal to ambient temperature.             | <ul style="list-style-type: none"> <li>• Normal discharging of the Refrigerant.</li> </ul>  |
| MOISTURE CLOG         |                  | Cooling operation stops periodically.                     | Flowing sound of refrigerant is not heard and frost melts.               | Lower than ambient temperature.           | <ul style="list-style-type: none"> <li>• Cooling operation restarts when heating the inlet of the capillary tube.</li> </ul>  |
| DEFECTIVE COMPRESSION | COMP-RESSION     | Freezer and Refrigerator don't cool.                      | Low flowing sound of refrigerant is heard and frost forms in inlet only. | A little higher than ambient temperature. | <ul style="list-style-type: none"> <li>• Low pressure at high side of compressor due to low refrigerant level.</li> </ul>   |
|                       | NO COMP-RESSION  | No compressing operation.                                 | Flowing sound of refrigerant is not heard and there is no frost.         | Equal to ambient temperature.             | <ul style="list-style-type: none"> <li>• No pressure in the high pressure part of the compressor.</li> </ul>  |

6-4-1 SEALED SYSTEM DIAGNOSIS

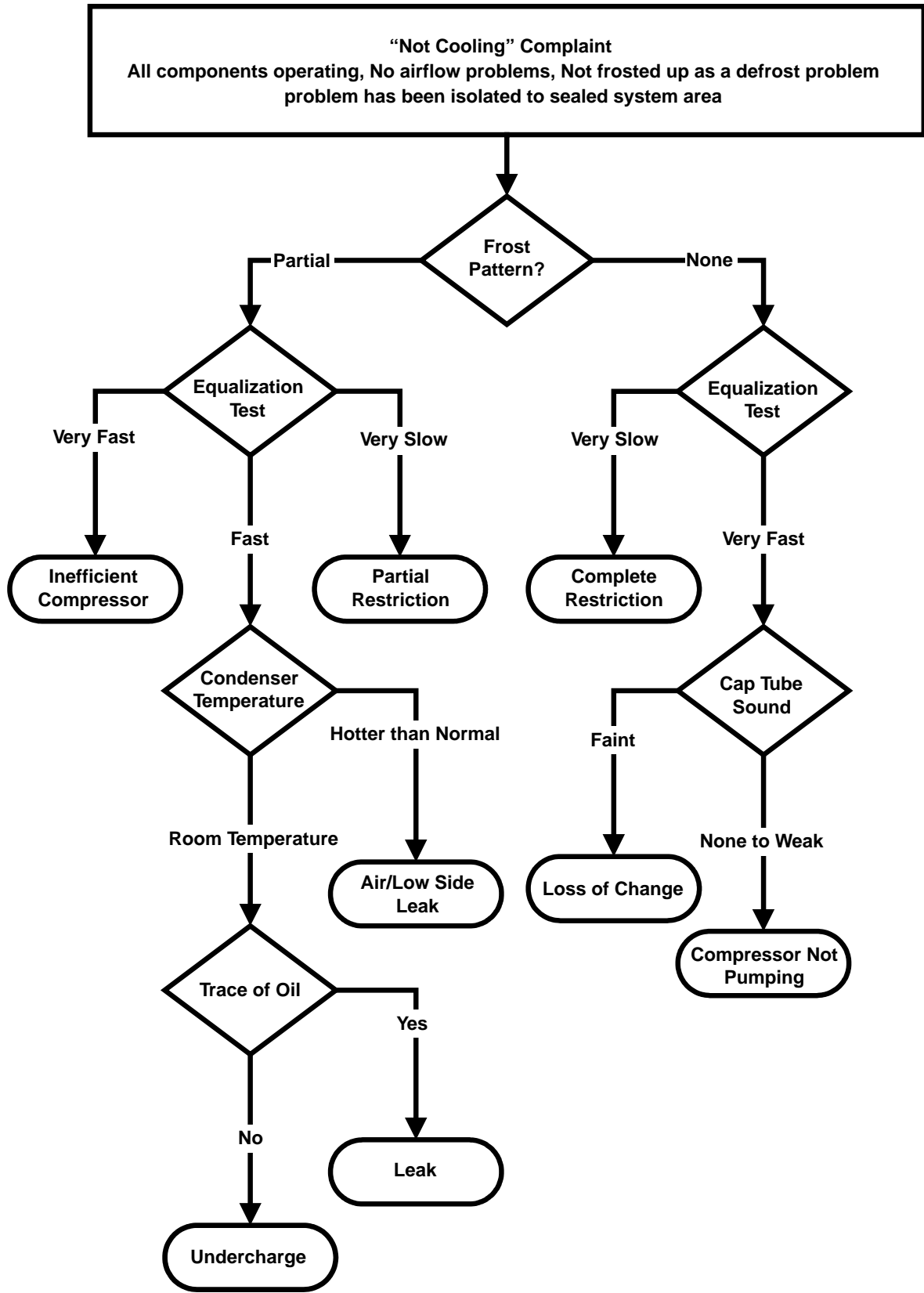

(The equalization test is trying to restart a compressor using a start kit after it has been operating.)

# 7. OPERATION PRINCIPLE AND REPAIR METHOD OF ICEMAKER

## 7-1 OPERATION PRINCIPLE

### 7-1-1 Operation Principle of IceMaker

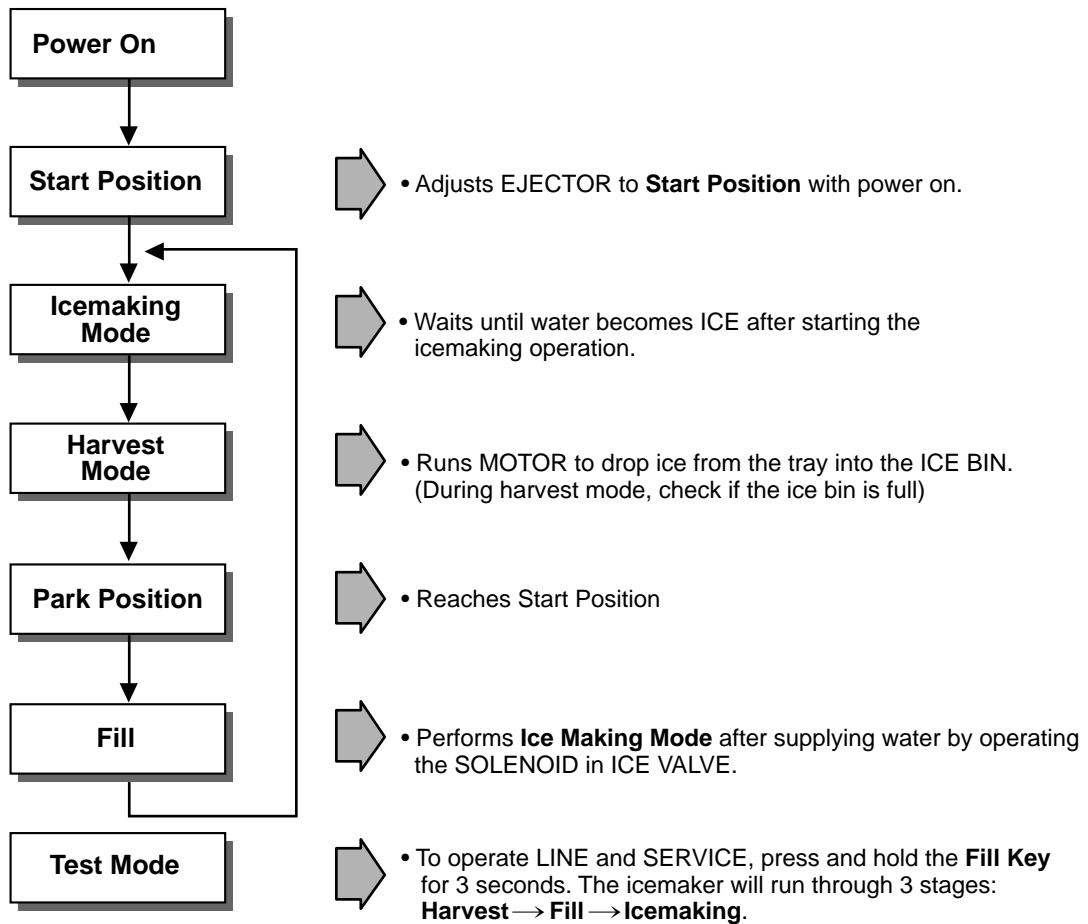

1. Turning the Icemaker stop switch off (O) stops the ice making function.
2. Setting the Icemaker switch to OFF and then turning it back on will reset the icemaker control.

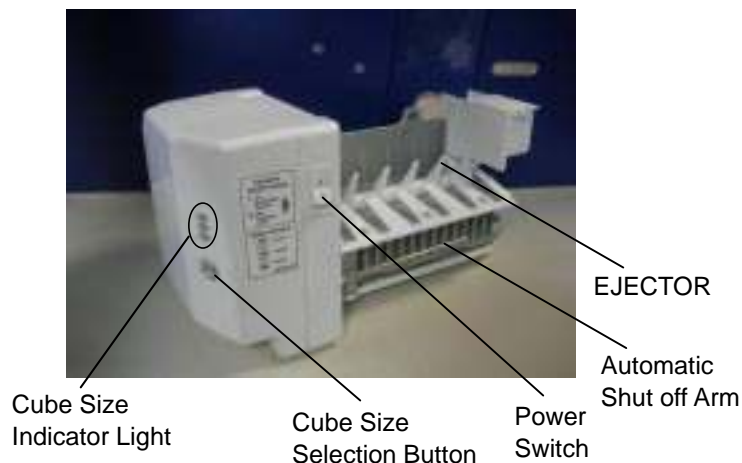

## 7-2 ICE MAKER FUNCTIONS

### 7-2-1. Icemaking Mode

1. Icemaking refers to the freezing of supplied water in the ice tray. Complete freezing is assured by measuring the temperature of the Tray with Icemaking SENSOR.
2. Icemaking starts after completion of the water fill operation.
3. The Ice Making function is completed when the sensor reaches 19°F (-7°C), 55 minutes after starting.

**NOTE** :After Icemaker Power is ON, the Icemaker heater will be on for test for 6 sec.



### 7-2-2. Harvest Mode

1. Harvest (Ice removing) refers to the operation of dropping ices into the ice bin from the tray when icemaking has completed.
  2. Harvest mode:
    - (1) The Heater is ON for 30 seconds, then the motor starts.
    - (2) The feeler arm senses the quantity of ice in the ice storage bin while rotating with the EJECTOR.
      - A. Ice storage bin is full : The EJECTOR stops (heater off).
      - B. Ice storage bin is not full : The EJECTOR rotates twice to open for ice.
- ※ If the EJECTOR does not rotate once within 5 minutes in B mode, separate heater control mode starts operating to prevent the EJECTOR from being constrained. (It is recommended that the user open for ice to return to normal mode.)

### 7-2-3. Fill/Park Position

1. Once a normal harvest mode has been completed, the water solenoid will be activated.
2. The amount of water is adjusted by pressing the Fill Key repeatedly. This changes the time allowed for fill as illustrated in the table below.





**Water supply amount TABLE**

| STAGE | TIME TO SUPPLY            | INDICATIONS   | REMARKS  |
|-------|---------------------------|---|--|
| 1     | 5 sec.                    |  | The water amount will vary depending on the water control Switch setting, as well as the water pressure of the connected water line. |
| 2     | 5.5 sec.<br>(FIRST STAGE) |  |  |
| 3     | 6 sec.                    |  |  |

### 7-2-4 Function TEST

1. This is a forced operation for TEST, Service, cleaning, etc. It is operated by pressing and holding the Fill Key for 3 seconds.
2. The test works only in the Icemaking Mode. It cannot be entered from the Harvest or Fill mode.
3. **Caution!** If the test is performed before water in the icemaker is frozen, the ejector will pass through the water. When the Fill mode begins (Stage 4), unless the water supply has been shut off, added water will overflow into the ice bin. If the control doesn't operate normally in the TEST mode, check and repair as needed.
4. After water is supplied, the normal CYCLE is followed: **icemaking Harvest Park Position Fill.**
5. Five seconds after Stage 5 is completed, the Ice Maker returns to MICOM control. The time needed to supply water resets to the pre- test setting.

#### Diagnosis TABLE

| STAGE | ITEMS      | INDICATOR   | REMARKS   |
|-------|------------|---|---|
| 1     | HEATER     |    | Five seconds after heater starts, a heater will go off if the temperature by sensor is higher than 10°C                   |
| 2     | MOTOR      |    | Five seconds after heater starts, you can confirm that a motor is moving.   |
| 3     | HALL IC I  |   | Check if Ice Bin is full or not. If Ice bin is full, the motor and heater are off and on stand by until Ice bin is empty. |
| 4     | HALL IC II |  | You can confirm HALL IC detection of start position.  |
| 5     | VALVE      |  | Two seconds after detection of start position, you can confirm that valve is on.  |
| 6     | Reset      | Return to Status prior to TEST MODE   | Five seconds after fifth stage is completed, The icemaker resets to initial status.                                       |

### 7-3 DEFECT DIAGNOSIS FUNCTION

#### 7-3-1 ERROR CODES shown on Ice Maker water supply control panel

| NO | DIVISION                     | INDICATOR   | CONTENTS                     | REMARKS  |
|----|------------------------------|---|------------------------------|--|
| 1  | Normal                       | Mark time to supply   | None                         | Display switch operates properly                     |
| 2  | Icemaking Sensor malfunction |  | Open or short-circuited wire | Make sure that the wire on each sensor is connected. |

# 8. DESCRIPTION OF FUNCTION & CIRCUIT OF MICOM

## 8-1 FUNCTION

### 8-1-1 Function

- When the appliance is plugged in, it is set to 37°F for Refrigerator and 0°F for freezer.  
You can adjust the Refrigerator and the Freezer control temperature by pressing the ADJUST button.
- When the power is initially applied or restored after a power failure, it is set to Control temperature Previously.

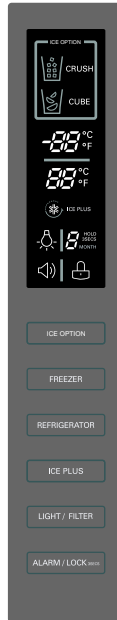

### 8-1-2 How to Toggle the Display between °F & °C

- The initial setting is °F and the display temperature mode can be changed from °F to °C or °C to °F by pressing and holding the FRZ TEMP and the REF TEMP keys at the same time for over 5 seconds.

### 8-1-3 Lock function (dispenser and display button lock)

- When the refrigerator is first turned on, the buttons are not locked. The display panel shows the padlock unlocked icon.
- To lock the display, the dispenser, and the control panel, press and hold the ALARM/ LOCK button for 3 seconds. The locked pad lock icon is displayed.
- The ALARM/ LOCK button is the only control feature that remains active in the locked state. The buzzer sound, other control buttons, and the dispenser are deactivated.
- To release from the locked state, press and hold the ALARM/LOCK button again for 3 seconds.

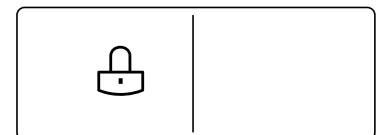

Ex) "LOCK"  
Function ON

Ex) "LOCK"  
Function OFF

### 8-1-4 Filter condition display function

- There is a replacement indicator for the filter cartridge on the dispenser.
- Water filter needs replacement once six months or of using water filter.
- Water Filter icon turn on to tell you need to replace the filter soon.
- After replacing the filter, press and hold the FILTER RESET button more than 3 seconds.  
HOLD 3 SECS icon turn off with reset status.

Classification

Filter Status  
Display

| In initial Power On / Filter RESET | Replace indicator light on |
|------------------------------------|----------------------------|
| 8 HOLD 3SECS MONTH                 | 8 MONTH                    |

### 8-1-5 Ice Plus selection

Please select this function for quick freezing.

¥ Function is repeat Ice Plus Icon whenever pressing Ice Plus button.

¥ Ice Plus function automatically turns off after a fixed time passes.



### 8-1-6 Dispenser use selection

#### 1. Water

\* Water switch: Hold your cup in the dispenser for a few seconds with pressing water switch to allow the last drops of water to fall into the cup.

\* Active water button: Place big bowl on the dispenser bottom with pressing active water button to allow the last drop of water to fall into the bowl.

\* When after initially establishing the water comes out, the water tank inside fills and until at the time of quality the hour is caught.

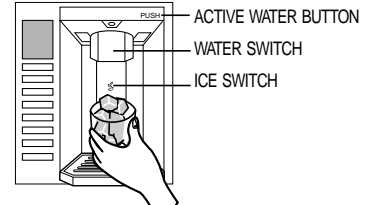

#### 2. Ice

\* You can select cube or crushed ice.

\* Select cube ice or crushed ice by cycling through the selections when pressing the ICE OPTION button.

\* Hold your cup in the dispenser for a few seconds with pressing ice switch to allow the last pieces of ice to fall into the cup.

### 8-1-7 DISPENSER LIGHT

Please select this function for DISPENSER LIGHT MODE.

1. Normal status (LIGHT icon is OFF): When dispenser is operated, DISPENSER LIGHT is ON.

2. ON status (LIGHT icon is ON): DISPENSER LIGHT is on continuously



### 8-1-8 CONTROL OF FREEZER FAN MOTOR

1. Freezer fan motor has high and standard speeds.

2. High speed is used at power-up, for Ice Plus, and when refrigerator is overloaded.

Standard speeds is used for general purposes.

3. To improve cooling speed, the RPM of the freezer fan motor change from normal speed to high.

4. High speed (2700RPM) : Initial power on or load corresponding operation, Ice Plus

Normal speed (2400RPM) : General working conditions.

5. Fan motor stops when refrigerator open.

### 8-1-9 Cooling Fan Motor

1. The cooling fan is switched ON and OFF in conjunction with the compressor.

2. The cooling fan runs at a single speed.

3. The Failure sensing method is the same as in the fan motor of the freezing fan motor(refer to failure diagnosis function table for failure display).

### 8-1-10 Icing Fan

The Icing Fan is controlled by the the sensor on the top of the ice room.

The Failure sensing method is the same as in the fan motor of the freezer (refer to failure diagnosis function table for failure display)

### 8-1-11 Ice Plus

1. The purpose of this function is to intensify the cooling speed of freezer and to increase the amount of ice.
2. Whenever selection switch is pressed, selection/release, the Icon will turn ON or OFF.
3. If there is a power outage and the refrigerator is powered on again, Ice Plus will be canceled.
4. To activate this function, press the Ice Plus key and the Icon will turn ON. This function will remain activated for 24 hrs. The first three hours the compressor and Freezer Fan will be ON. The next 21 hours the freezer will be controlled at the lowest temperature. After 24 hours or if the Ice Plus key is pressed again, the freezer will return to its previous temperature.
5. During the first 3 hours:
  - (1) Compressor and freezer fan (HIGH RPM) run continuously.
  - (2) If a defrost cycle begins during the first 90 minutes of Ice Plus, the Ice Plus cycle will complete its cycle after defrosting has ended.  
If the defrost cycle begins when Ice Plus has run for more than 90 minutes, Ice Plus will run for two hours after the defrost is completed.
  - (3) If Ice Plus is pressed during defrost, Ice Plus Icon is on but this function will start seven minutes after defrost is completed and it shall operate for three hours.
  - (4) If Ice Plus is selected within seven minutes after compressor has stopped, the compressor (compressor delays seven minutes) shall start after the balance of the delay time.
  - (5) The fan motor in the freezer compartment runs at high speed during Ice Plus.
6. For the rest of the 21 hours, the freezer will be controlled at the lowest temperature.

### 8-1-12 Alarm for Open Door

1. This feature sounds a buzzer when the freezer or refrigerator door is not closed within 1 minute after it is opened.
2. One minute after the door is opened, the buzzer sounds three times each for 1/2 seconds. These tones repeat every 30 seconds.
3. The alarm is cancelled when the freezer or the refrigerator is closed while the buzzer sounds.

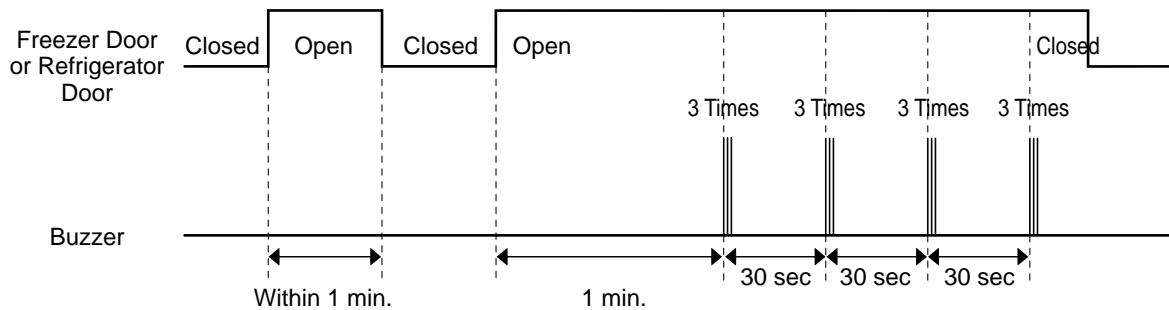

### 8-1-13 Defrosting (removing frost)

1. Defrosting starts each time the accumulated COMPRESSOR running time is between 7:30 and 40 hours. This time is determined by how often and how long the doors are opened.
2. For initial power on or for restoring power, defrosting starts when the compressor running time reaches 4 hours.
3. Defrosting stops if the sensor temperature reaches 46.4°F(8°C) or more. If the sensor doesn't reach 46.4°F(8°C) in 1 hour, the defrost mode is malfunctioning. (Refer to the defect diagnosis function, 8-1-14.)
4. Defrosting won't function if its sensor is defective (wires are cut or short circuited)

### 8-1-14 Defect Diagnosis Function

1. Automatic diagnosis makes servicing the refrigerator easy.
2. When a defect occurs, the buttons will not operate; but the tones, such as ding, will sound.
3. When the defect CODE removes the sign, it returns to normal operation (RESET).
4. The defect CODE shows on the Refrigerator and Freezer Display.

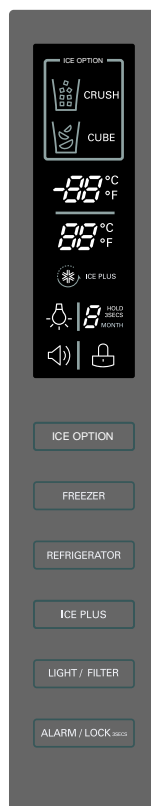

LED check function: If simultaneously pressing Ice Plus button and Frz Temp. for a second, display LED graphics on. If releasing the button, the LED graphic displays the previous status.

#### Demonstration Mode (Off Mode)

1. Any Door must be opened to enter in this mode
2. To activate this mode press and hold Ice Plus and Refrigerator buttons over 5 seconds.
3. The display will show the word "OFF"
4. In this mode all loads are turn Off (Compressor, Heater, Fans, etc)
5. Lamps and Dispenser Functions works normally.  
(Even in demonstration mode the refrigerator Lamp automatic off function works normally)
6. To exit Demonstration mode open any Door then press and hold Ice Plus and Refrigerator buttons over 5 seconds (Display return to normal mode).

**ERROR CODE on display panel**

| No. | ITEM  | ERROR CODE                        |          | CONTENTS   | REMARKS   |
|-----|---|-----------------------------------|----------|--|---|
|     |   | FRZ TEMP                          | REF TEMP |  |   |
| 1   | Failure of Freezer sensor                                       | Er                                | FS       | Cut or short circuit wire.   | Inspect Connecting wires on each sensor   |
| 2   | Failure of Refrigerator sensor                                  | Er                                | rS       | Cut or short circuit wire.   |   |
| 3   | Failure of defrost sensor                                       | Er                                | dS       | Cut or short circuit wire.   |   |
| 4   | Failure of Room Temperature sensor                              | When display check mode:<br>Er rt |          | Cut or short circuit wire.   |   |
| 5   | Failure of Icing sensor   | Er                                | IS       | Cut or short circuit wire.   |   |
| 6   | Failure of defrost mode   | Er                                | dH       | When defrost sensor doesn't reach 46°F(8°C) within 1 hour after starting defrost | Snapping of defrost heater or Temperature fuse, pull-out of connector (indicated minimum 1 hour after failure occurs) |
| 7   | Failure of BLDC Fan Motor at Freezing Compartment               | Er                                | FF       | If there is no fan motor signal for more than 115sec in operation fan motor      | Poor motor, hooking to wires of fan, contact of structures to fan, snapping or short circuit of Lead wires            |
| 8   | Failure of BLDC Fan Motor for Ice Maker at Freezing compartment | Er                                | IF       | If there is no fan motor signal for more than 114sec in operation fan motor      | Poor motor, hooking to wires of fan, contact of structures to fan, snapping or short circuit of Lead wires            |
| 9   | Failure of Communication between display and Main PCB           | Er                                | CO       | If there is no communication between display and main PCB                        | check the wires of display connection   |

LED check function: If simultaneously pressing Ultra Ice button and Frz Temp for a second, display LED graphics on. If releasing the button, the LED graphic displays the previous status.

## 8-1-16 TEST Mode

1. The Test mode allows checking the PCB and the function of the product as well as finding out the defective part in case of an error.
2. The test mode is operated by pressing test button at main PCB controller.
3. While in the test mode, the function control button is not recognized, but the recognition tone sounds.
4. After exiting the test mode, be sure to reset by unplugging and then plugging in the appliance.
5. If an error, such as a sensor failure, is detected while in the test mode, the test mode is cleared and the error code is displayed.
6. While an error code is displayed, the test mode will not be activated.

**Table 1. Function Test**

| MODE  | OPERATION                                  | FUNCTION  | REMARKS  |
|-------|--|---|--|
| TEST1 | Push Test Switch (in the main Board) once. | 1) Continuous operation of the COMPRESSOR and the Freezer fan<br>2) Stepping DAMPER OPEN<br>3) Defrosting HEATER OFF<br>4) DISPLAY LED all ON       | Maximum test time: 5 minutes   |
| TEST2 | Push TEST Switch once in TEST MODE1.       | 1) Continuous operation of the COMPRESSOR and the Freezer fan<br>2) Stepping DAMPER CLOSE<br>3) Defrosting HEATER OFF<br>4) DISPLAY LED shows no. 2 | Maximum test time: 5 minutes   |
| TEST3 | Push TEST Switch once in TEST MODE 2.      | 1) COMPRESSOR and the Freezer fan OFF<br>2) Stepping DAMPER CLOSE<br>3) Defrosting HEATER ON<br>4) DISPLAY LED shows no. 3                          | Reset if the Temperature of the Defrosting Sensor is 46°F(8°C)or more. |
| RESET | Push TEST Switch once in TEST MODE3.       | Reset to the previously setting Before TEST MODE.   | The compressor will Start after a 7-minute Delay.                      |

## 8-2 PCB FUNCTION

### 8-2-1 Power Circuit

1. Power is supplied to the control board at pin1 and 3 of connector #1.

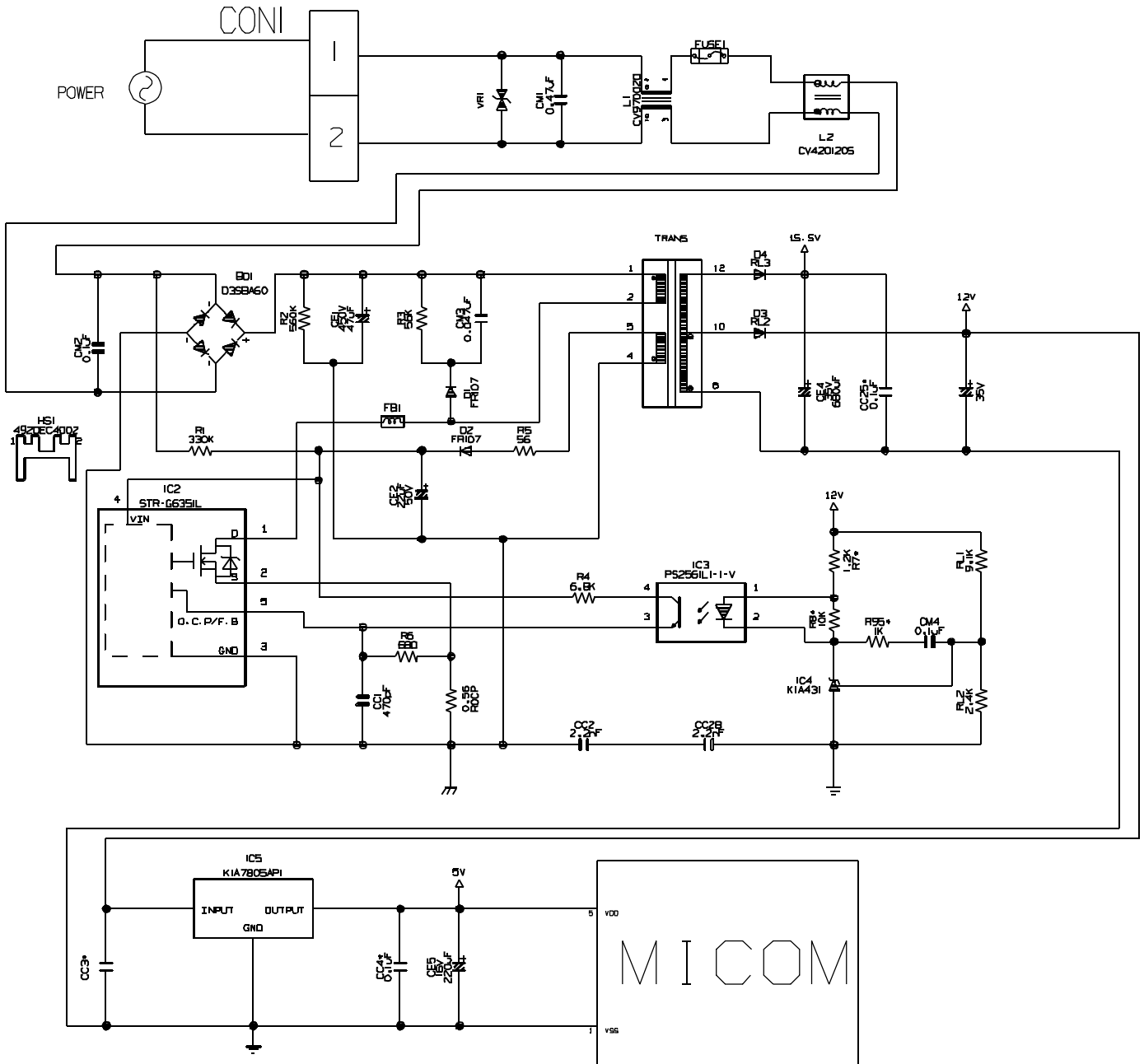

## 8-2-2 Load / Fan & Open Door Detection Circuit

### 1. Load Drive Condition Check

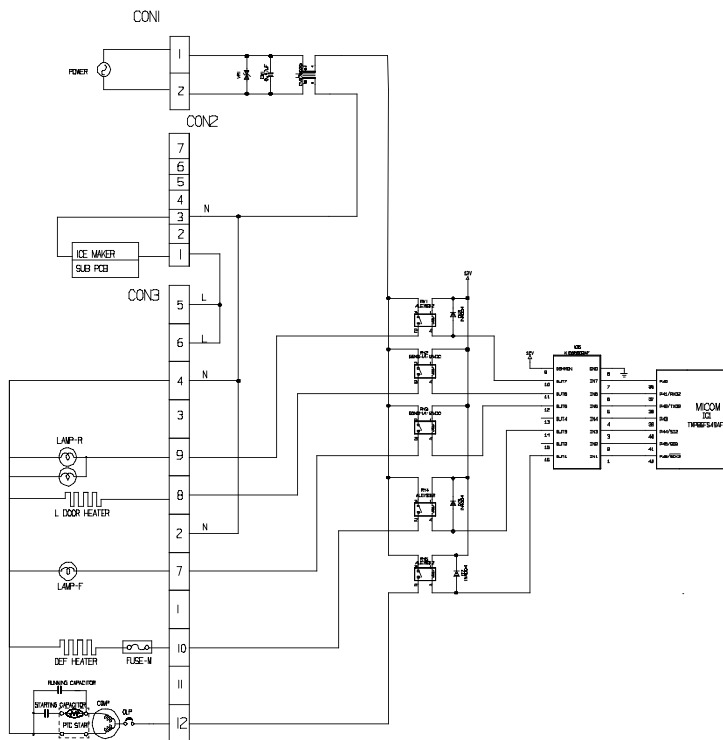

To measure outputs of the control board, check voltages between the pins for the following components:



| CONNECTOR 2 |     |     |     |     |   |     |          |
|-------------|-----|-----|-----|-----|---|-----|----------|
| PIN         | 7   | 6   | 5   | 4   | 3 | 2   | 1        |
|             | N/C | N/C | N/C | N/C | N | N/C | ICE MKFR |

| CONNECTOR 3 |    |    |            |        |        |        |
|-------------|----|----|------------|--------|--------|--------|
| PIN         | 12 | 11 | 10         | 9      | 8      | 7      |
|             | 6  | 5  | 4          | 3      | 2      | 1      |
| REG COM     | -- | -- | DEF HEATER | LAMP-R | FD-RTR | LAMP-F |
| --          | -- | N  | --         | --     | --     | --     |

\*LOAD DRIVE AREA ON MAIN PCB

| Circuit        | Pin Number | Pin Number | Output Voltage |
|----------------|------------|------------|----------------|
| Lamp-R         | Con3 Pin9  | Con3 Pin4  | 115 VAC        |
| Lamp-F         | Con3 Pin7  | Con3 Pin4  | 115 VAC        |
| Defrost Heater | Con3 Pin10 | Con3 Pin4  | 115 VAC        |
| Compressor     | Con3 Pin12 | Con3 Pin4  | 115 VAC        |
| L-Door Heater  | Con3 Pin8  | Con3 Pin4  | 115 VAC        |
| Ice Maker      | Con2 Pin1  | Con3 Pin4  | 115 VAC        |

To measure output of the fans on the control board check voltages between the pins for the following components:

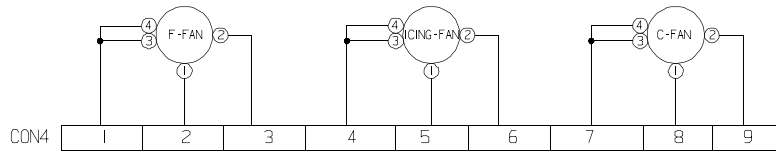

| FAN                      | PIN NUMBER | PIN NUMBER | OUTPUT VOLTAGE  |               |
|--------------------------|------------|------------|-----------------|---------------|
|                          |            |            | MOTOR ON        | MOTOR OFF     |
| Freezing compartment fan | Con4 Pin1  | Con4 Pin2  | 13 VDC - 15 VDC | 2 VDC or less |
| Machine compartment fan  | Con4 Pin7  | Con4 Pin8  | 13 VDC - 15 VDC | 2 VDC or less |
| Icing compartment fan    | Con4 Pin4  | Con4 Pin5  | 13 VDC - 15 VDC | 2 VDC or less |



| CONNECTOR 4 |       |   |   |           |   |   |       |   |   |            |    |
|-------------|-------|---|---|-----------|---|---|-------|---|---|------------|----|
| PIN         | 1     | 2 | 3 | 4         | 5 | 6 | 7     | 8 | 9 | 10         | 11 |
|             | F-FAN |   |   | ICING-FAN |   |   | C-FAN |   |   | R-DOOR S/W |    |
|             | V     | G | F | V         | G | F | V     | G | F |            |    |

### 3. Open Door Detection Circuit Check

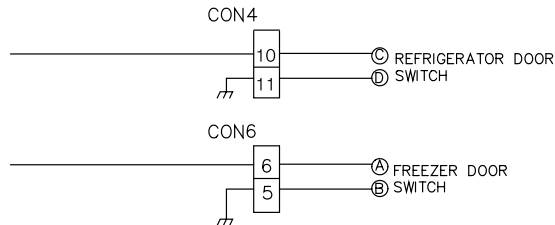

| Measurement Location | Pin 10 & 11 of con4 Ref.Door<br>Pin 5 & 6 of con6 Fre.Door |
|----------------------|--|
| Closed               | 5 V  |
| Open                 | 0 V  |



| CONNECTOR 4 |       |   |   |           |   |   |       |   |   |            |    |
|-------------|-------|---|---|-----------|---|---|-------|---|---|------------|----|
| PIN         | 1     | 2 | 3 | 4         | 5 | 6 | 7     | 8 | 9 | 10         | 11 |
|             | F-FAN |   |   | ICING-FAN |   |   | C-FAN |   |   | R-DOOR S/W |    |
|             | V     | G | F | V         | G | F | V     | G | F |            |    |



| CONNECTOR 6 |                |   |   |            |   |   |       |   |       |    |       |    |
|-------------|----------------|---|---|------------|---|---|-------|---|-------|----|-------|----|
| PIN         | 1              | 2 | 3 | 4          | 5 | 6 | 7     | 8 | 9     | 10 | 11    | 12 |
|             | STEPPING MOTOR |   |   | F-DOOR S/W |   |   | D-SNR |   | R-SNR |    | F-SNR |    |

### 8-2-3 Temperature Sensor Circuit

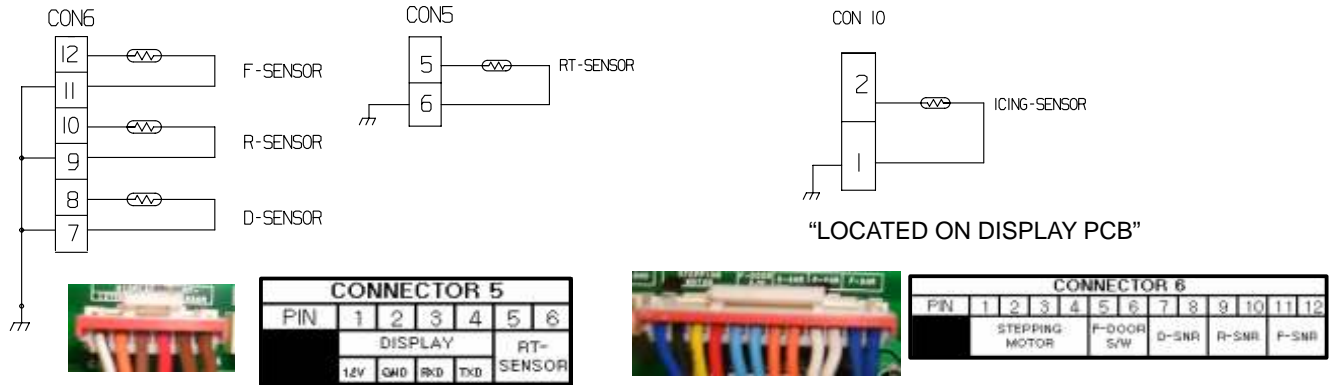

| TEMPERATURE      | RESISTANCE OF FREEZER/Icing SENSOR | RESISTANCE OF REFRIGERATOR & DEFROST SENSOR & ROOM SENSOR |
|------------------|------------------------------------|---|
| - 20 °C (-4 °F)  | 22.3 K?                            | 77 K?   |
| - 15 °C (5°E)    | 16.9 K?                            | 60 K?   |
| - 10 °C (14 °F)  | 13.0 K?                            | 47.3 K?   |
| - 5 °C (23 °F)   | 10.1 K?                            | 38.4 K?   |
| 0 °C (32 °F)     | 7.8 K?                             | 30 K?   |
| + 5 °C (41 °F)   | 6.2 K?                             | 24.1 K?   |
| + 10 °C (50 °F)  | 4.9 K?                             | 19.5 K?   |
| + 15 °C (59 °F)  | 3.9 K?                             | 15.9 K?   |
| + 20 °C (68 °F)  | 3.1 K?                             | 13 K?   |
| + 25 °C (77 °F)  | 2.5 K?                             | 11 K?   |
| + 30 °C (86 °F)  | 2.0 K?                             | 8.9 K?  |
| + 40 °C (104 °F) | 1.4 K?                             | 6.2 K?  |
| + 50 °C (122 °F) | 0.8 K?                             | 4.3 K?  |

- The resistance of the SENSOR has a  $\pm 5\%$  common difference.
- Measure the resistance of the SENSOR after leaving it for over 3 minutes in the measuring temperature. This delay is necessary due to sensor response speed.

### 8-2-4 Refrigeration Compartment Stepping Motor Damper Circuit

A reversible DC motor is used to open and close the damper.

To open the damper, push test button once.

To close the damper, push test button twice.

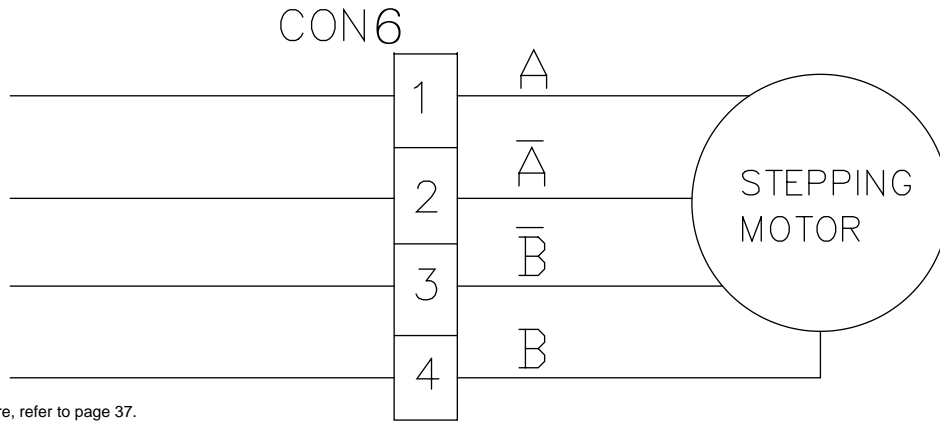

To see connector 6 picture, refer to page 37.

### 8-2-5 Dispenser Drive Circuit

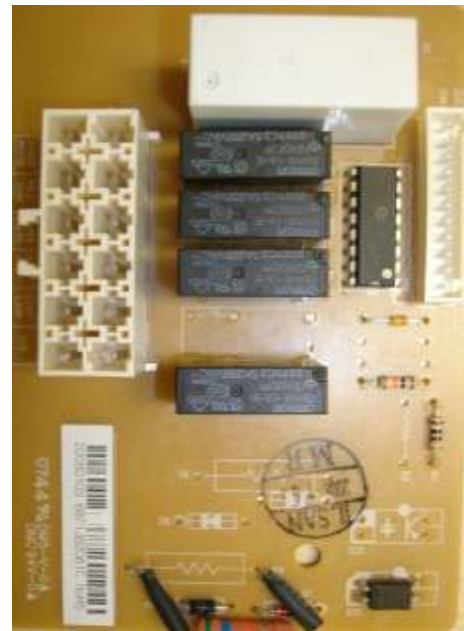
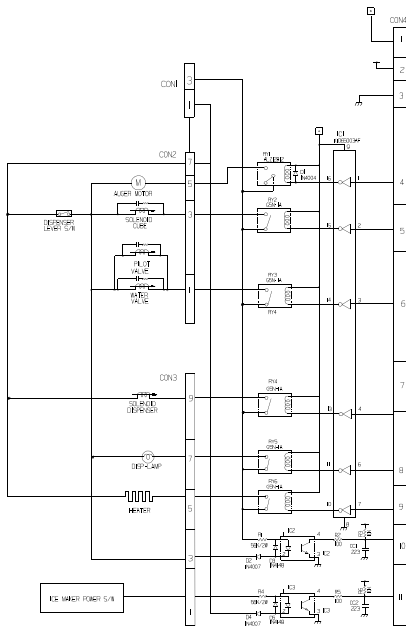

| Circuit            | Pin Number | Pin Number | Output Voltage |
|--------------------|------------|------------|----------------|
| Auger Motor        | Con1 Pin12 | Con1 Pin4  | 115 VAC        |
| Solenoid Cube      | Con1 Pin11 | Con1 Pin4  | 115 VAC        |
| Pilot/ Water Valve | Con1 Pin10 | Con1 Pin4  | 115 VAC        |
| Solenoid Dispenser | Con1 Pin9  | Con1 Pin4  | 115 VAC        |
| Heater             | Con1 Pin7  | Con1 Pin4  | 115 VAC        |

## 8-3 TROUBLESHOOTING

| PROBLEM               | INDICATED BY                            | CHECK  | CHECKING METHOD  | CAUSE                                       | SOLUTION  |
|-----------------------|---|--|--|---|---|
| POWER SOURCE is poor. | 1. The whole<br><br>2. DISPLAY LED      | 1. FREEZER/ REFRIGERATOR.                    | Check if FREEZER/REFRIGERATOR DOOR IS OPEN and check display.  | POWER SOURCE is poor.                       | Replace Main PWB  |
|                       |   | 2. If LAMP is dim.                           | Check visually.  | Applied voltage error.                      | Replace Main PWB  |
|                       |   | 3. The connection of the MAIN PWB CONNECTOR. | Check connection of CONNECTOR.   | CONNECTOR connection is poor.               | Reconnect CONNECTOR   |
| TRANS FUSE is open.   | Replace Main PWB                        |  |  |   |   |
| COOLING is poor.      | NO COOLING.                             | 1. If the COMPRESSOR operate.                | USE TEST MODE1 (forced COOLING). If less than 7 minutes pass after compressor shuts off, don't press the KEY and wait. | COMPRESSOR locked or blocked.               | Replace OLP, PTC.   |
|                       |   |  |  | OLP, PTC is poor. COMPRESSOR RELAY is poor. | Replace MAIN PWB.   |
|                       |   |  |  | THE CONNECTING WIRE is poor.                | Check the connection of the black wire of the MAIN PWB CONNECTOR (CON3).                              |
|                       |   |  |  | 2. If refrigerant is leaking.               | Measure the amount of frost sticking on EVAPORATOR and the surface temperature of the condenser pipe. |
|                       | FREEZER TEMPERATURE is incorrect        | 1. If FAN MOTOR operates.                    | USE TEST MODE1 (forced COOLING).   | FAN MOTOR is poor.                          | Replace the FAN MOTOR.  |
|                       |   |  |  | CONNECTING WIRE is poor.                    | Certify the MOTOR and the connection of the black wire of the MAIN PWB CONNECTOR (CON4).              |
|                       |   | 2. If DEFROSTING is normal.                  | Check the amount of frost sticking on the EVAPORATOR .   | DEFROSTING is poor.                         | See DEFROSTING is poor.   |
|                       |   | 3. If SENSOR is normal.                      | of the Refrigerator SENSOR.  | SENSOR RESISTANCE is poor.                  | Replace SENSOR.   |
| 4. Door Line contact. | Check the seal when the door is closed. | Door liner damaged.                          | Replace door liner.  |   |   |

| PROBLEM             | INDICATED BY                            | CHECK  | CHECKING METHOD  | CAUSE                           | SOLUTION  |
|---------------------|---|--|--|---------------------------------|---|
| COOLING is poor.    | If REFRIGERATOR TEMPERATURE is too low. | 1. If FREEZER TEMPERATURE is normal.                   | Check is FREEZER TEMPERATURE is too low.   |                                 | Make sure the DOOR is attached.                             |
|                     |   | 2. If amount of cool air from FAN MOTOR is sufficient. | Make sure that the amount and speed of cool air are sufficient by touching the check supplied on the REFRIGERATOR. | FAN MOTOR is poor.              | Replace FAN MOTOR.  |
|                     |   |  |  | Passage of cool air is blocked. | Remove impurities.  |
|                     |   | 3. Door Line contact.                                  | Check door seal when door is closed.   | EVA frozen.                     | See DEFROSTING is poor.                                     |
| Door liner damaged. | Replace Door liner.                     |  |  |                                 |   |
| DEFROSTING is poor. | NO DEFROSTING.                          | 1. If HEATER emits heat.                               | USE TEST MODE3 (forced DEFROSTING).  | HEATER disconnection.           | Replace HEATER.   |
|                     |   |  |  | TEMPERATURE FUSE disconnection. | Replace TEMPERATURE FUSE.                                   |
|                     |   |  |  | Connection is poor.             | Check EVAPORATOR connection and wire of MAIN PWB CONNECTOR. |
|                     |   |  |  | DEFROST-SENSOR is poor.         | Replace DEFROST-SENSOR.                                     |
|                     |   | 2. If DRAIN PIPE is blocked.                           | Check DRAIN PIPE.  | DRAIN PIPE is blocked.          | Remove ice and impurities.                                  |
|                     |   |  |  |                                 | Check HEATER PLATE resistance.                              |
|                     |   | 3. If ice remains after DEFROSTING.                    | Make sure that DEFROST SENSOR is connected.  | Connection is poor.             | Reassemble the DEFROST-SENSOR.                              |
|                     |   |  |  |                                 | Make sure that FREEZER /REFRIGERATOR DOOR is closed.        |



### 8-4-2 Dispenser Drive PWB Assembly

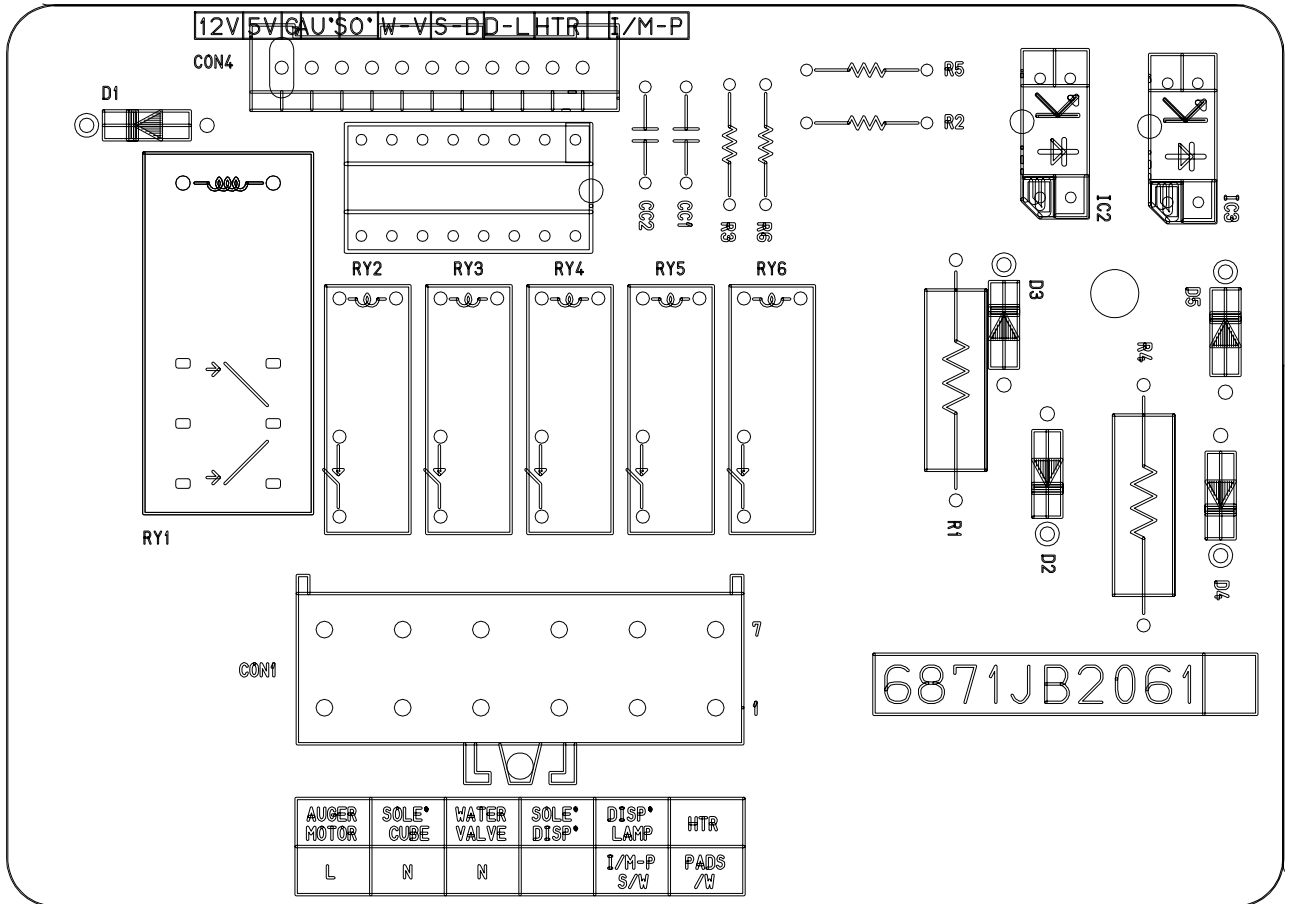



FREEZER PARTS

Caution: Use the part number to order part, not the position number.

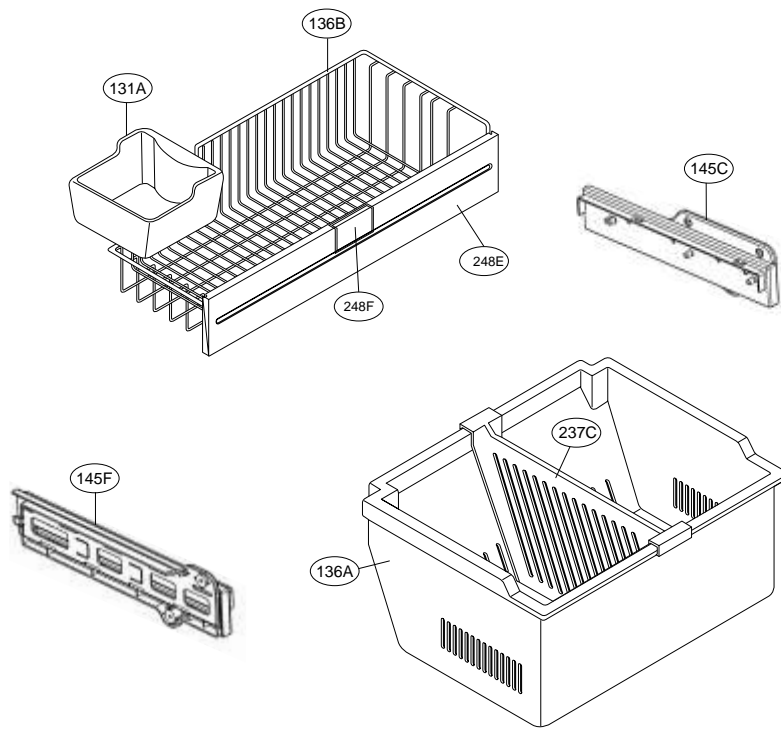

REFRIGERATOR PARTS

Caution: Use the part number to order part, not the position number.

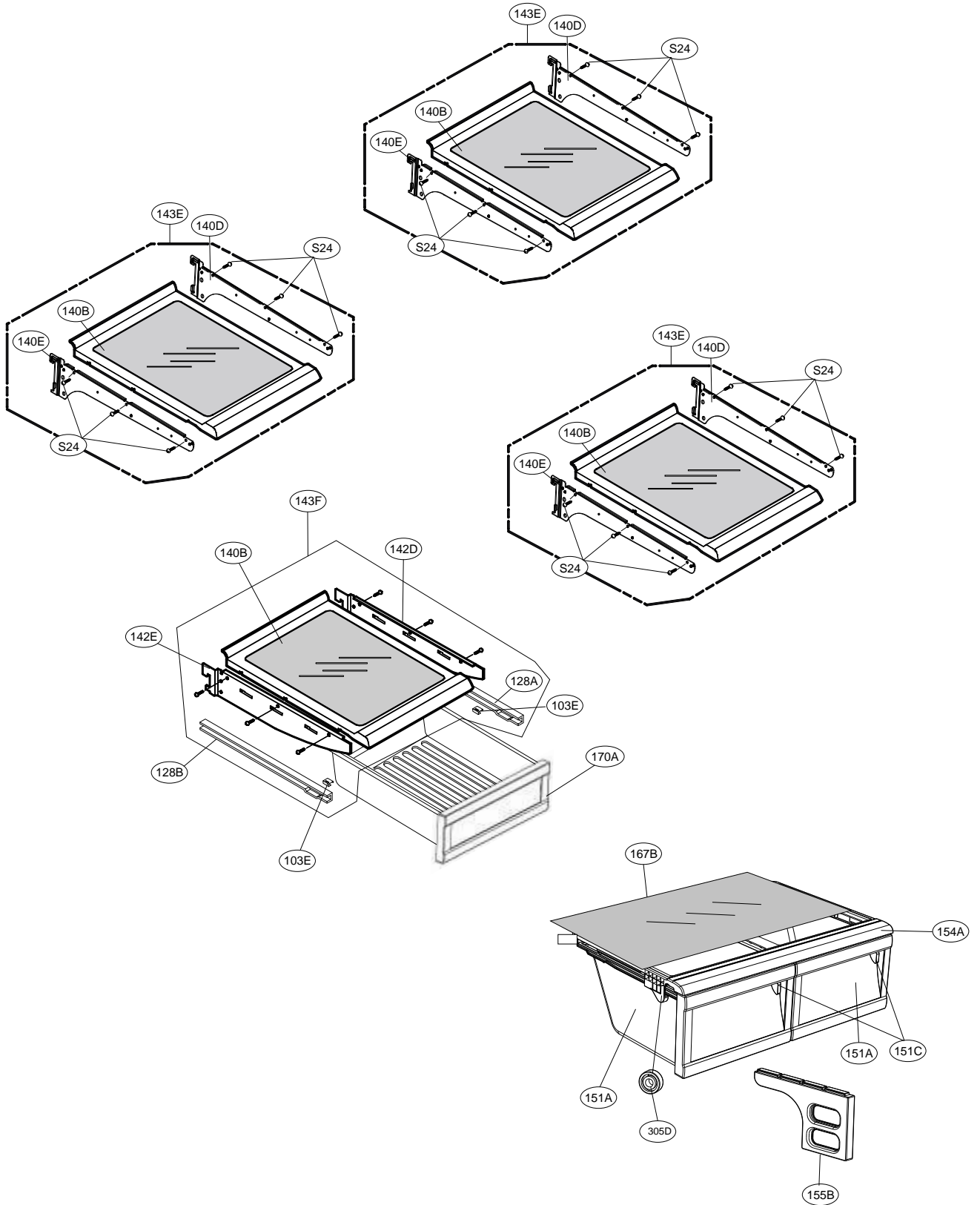

DOOR PARTS

Caution: Use the part number to order part, not the position number.

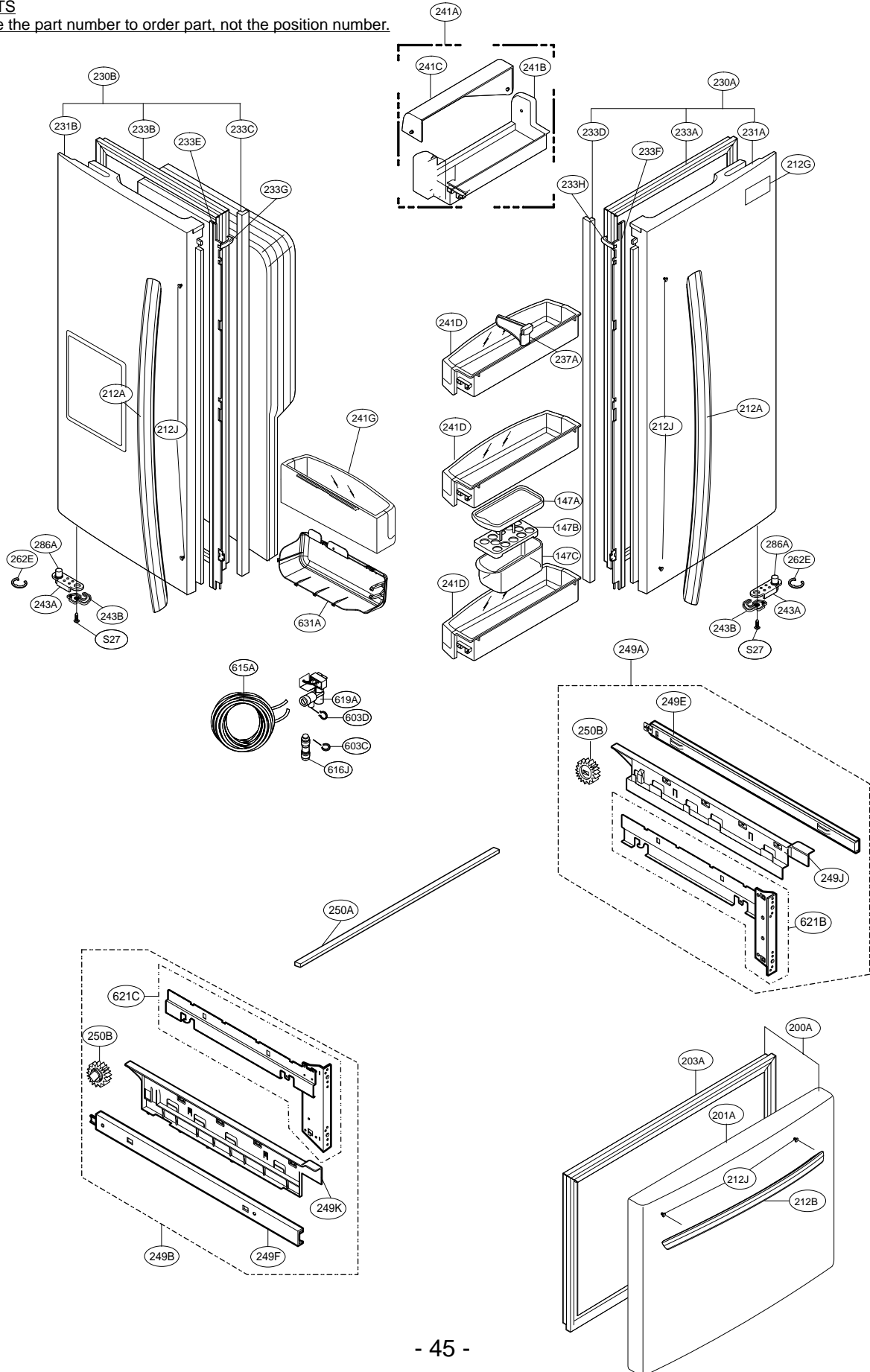

DISPENSER PARTS

Caution: Use the part number to order part, not the position number.

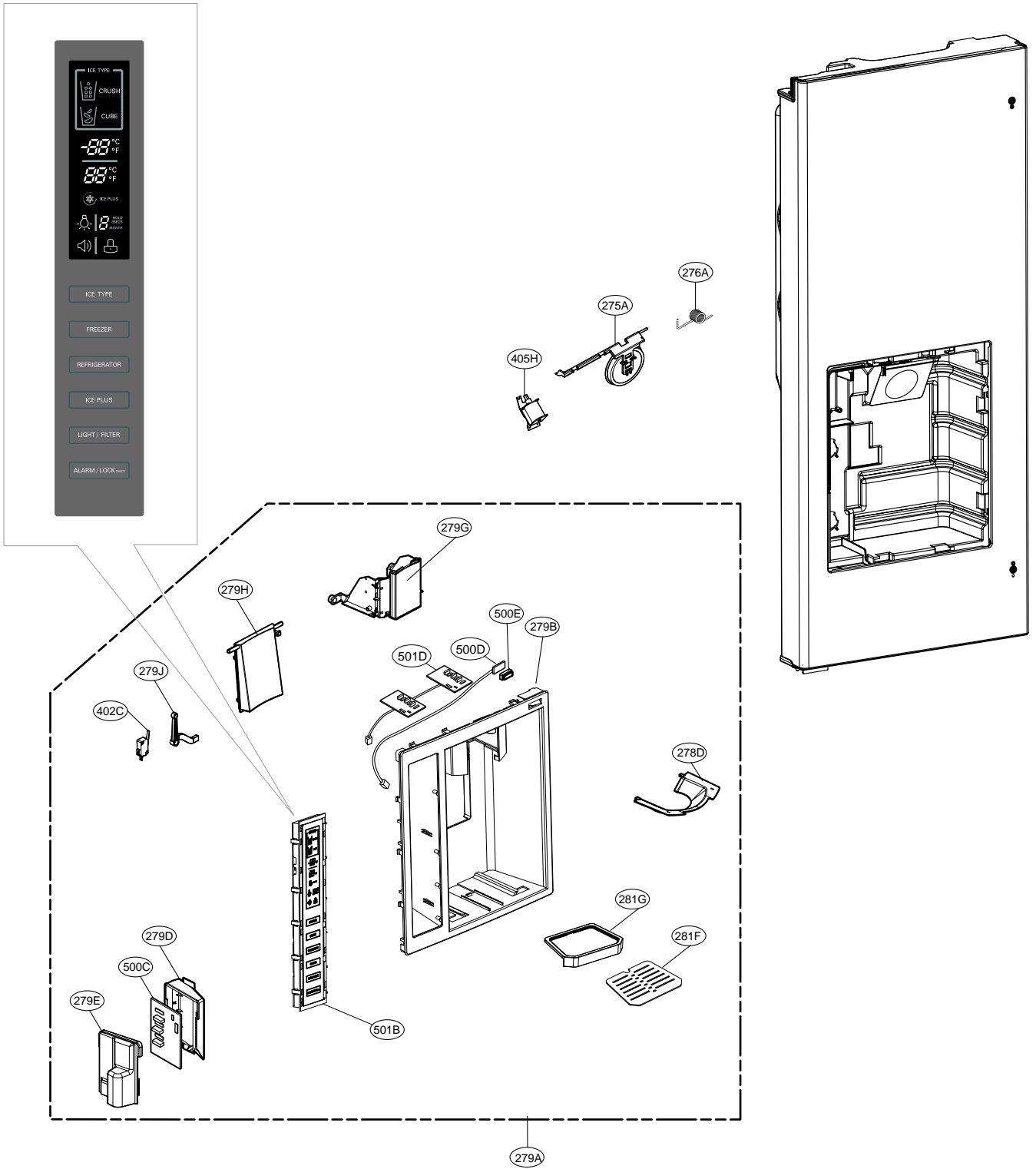

**ICE MAKER & ICE BANK PARTS**

Caution: Use the part number to order part, not the position number.

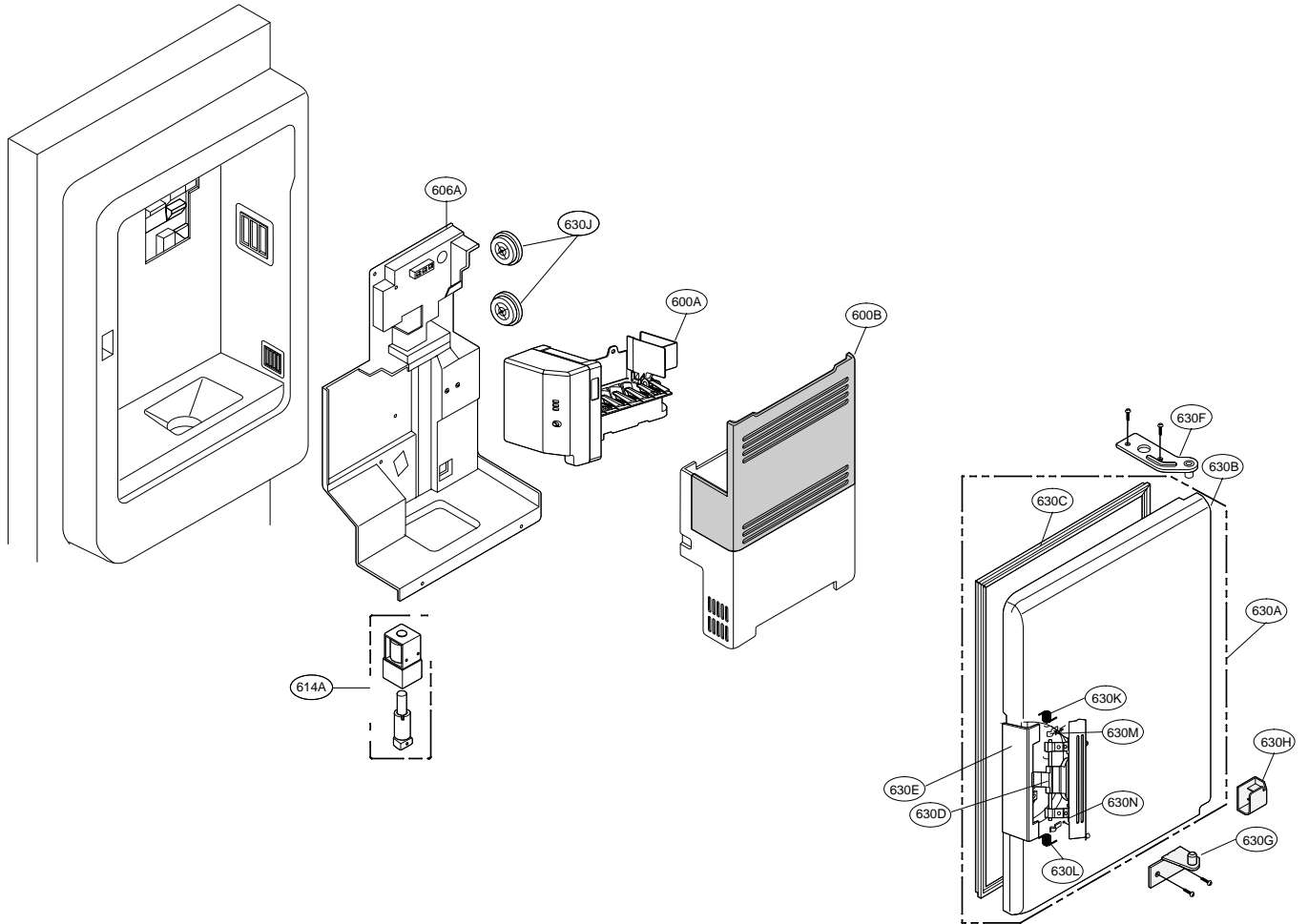

VALVE & WATER PARTS

Caution: Use the part number to order part, not the position number.

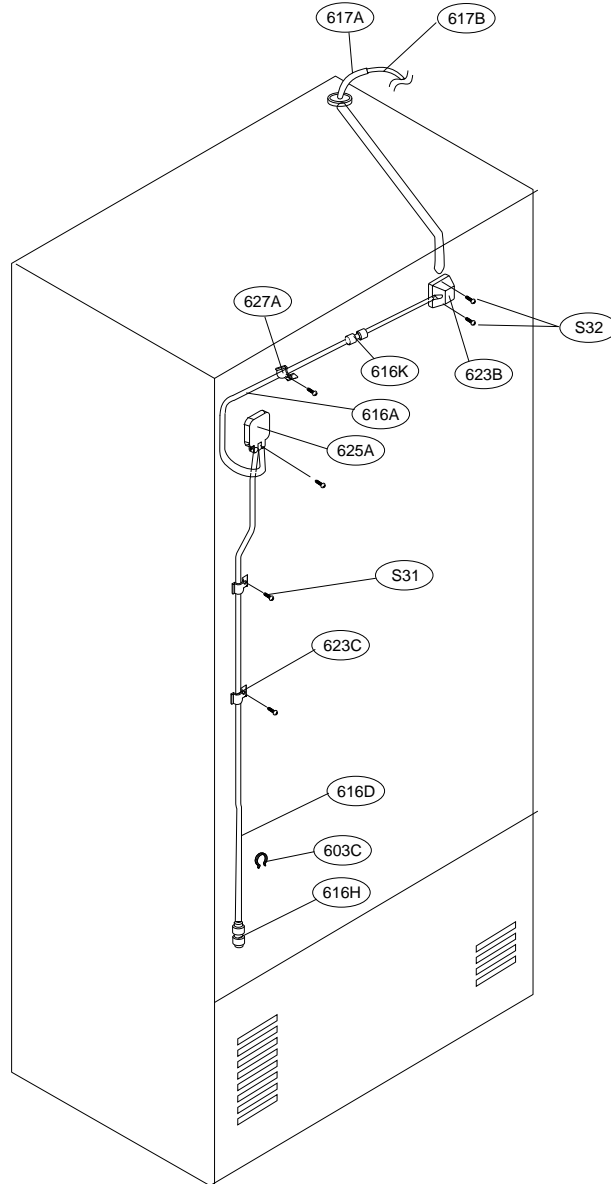

| LOC NO | PART NO     | DESCRIPTION                       | LOC NO | PART NO     | DESCRIPTION                           |
|--------|-------------|-----------------------------------|--------|-------------|---------------------------------------|
| 103A   | 3650JJ2003H | Handle,Rear                       | 304A   | 3551JJ2008B | Cover Assembly,Machinery(Rear)        |
| 103B   | 3650JJ2003D | Handle,Rear                       | 305B   | 4580JJ3001A | Roller                                |
| 103C   | 3551JJ1015H | Cover Assembly,Lower              | 305B   | 4580JJ3001A | Roller                                |
| 103E   | 5218JJ3001A | Rail,Slide                        | 305C   | 4J04238A    | Pin,Common                            |
| 103E   | 5218JJ3001A | Rail,Slide                        | 305C   | 4J04238A    | Pin,Common                            |
| 104E   | 4931JJ3002A | Holder Assembly,Gasket            | 305D   | 4580JA3042A | Roller                                |
| 105F   | 5070JJ3002A | Skirt,Lower                       | 307A   | TCA31748001 | Compressor,Set Assembly               |
| 106A   | 4779JA2003A | Leg Assembly,Adjust               | 308A   | 6748C0004D  | Thermistor Assembly,PTC               |
| 120B   | 5209JJ1002C | Duct Assembly,Multi               | 309A   | 6750C0004R  | Overload Protect                      |
| 125D   | 4930JJ3007A | Holder,Bracket                    | 310A   | 3550JA2059A | Cover,PTC                             |
| 128A   | 4975JJ2002A | Guide Assembly,Rail               | 312A   | 5040JA3031A | Damper,Compressor                     |
| 128B   | 4975JJ2002B | Guide Assembly,Rail               | 314A   | 4620JA3009A | Stopper,Compressor                    |
| 128E   | 4930JJ1025A | Holder,Rail                       | 315A   | 3103JJ1001J | Base Assembly,Compressor              |
| 128F   | 4930JJ1025B | Holder,Rail                       | 317A   | 5851JJ2002F | Drier Assembly                        |
| 131A   | MKK42003201 | Bucket,Ice                        | 318A   | 4930JA3034A | Holder,Drier                          |
| 136A   | 3391JJ1011B | Tray Assembly,Drawer              | 319A   | 3390JJ0004A | Tray,Drip                             |
| 136B   | MJS42003601 | Tray,Drawer                       | 319C   | MEA41997401 | Guide,Fan                             |
| 140B   | 5027JJ2007B | Shelf Assembly,Refrigerator       | 319E   | 4810JJ2005A | Bracket,Motor                         |
| 140B   | 5027JJ2007B | Shelf Assembly,Refrigerator       | 323B   | 5403JJ1007A | Condenser Assembly,Wire               |
| 140D   | MHL38615403 | Shelf,Net                         | 327A   | 5006JA3034A | Cap,Drain Tube                        |
| 140E   | MHL38615404 | Shelf,Net                         | 328B   | 4J04328A    | Damper,Pipe                           |
| 142D   | 5026JJ2001L | Shelf,Net                         | 329A   | 5901JJ1005A | Fan Assembly                          |
| 142E   | 5026JJ2001M | Shelf,Net                         | 329C   | ADP36665702 | Fan Assembly                          |
| 143E   | 5027JJ1008K | Shelf Assembly,Refrigerator       | 332A   | AEB36834001 | Grille Assembly,Fan                   |
| 143F   | 5027JJ1008D | Shelf Assembly,Refrigerator       | 401A   | 6615JB2005C | Controller Assembly                   |
| 145A   | 4930JJ2003A | Holder,Shelf                      | 402A   | 6600JB3007B | Switch,Push Button                    |
| 145B   | 4930JJ2004A | Holder,Shelf                      | 402A   | 6600JB3007B | Switch,Push Button                    |
| 145C   | 4975JJ2028C | Guide Assembly,Rail               | 404A   | EAU52096201 | Motor,DC                              |
| 145F   | 4975JJ2028D | Guide Assembly,Rail               | 405A   | 4810JJ0001A | Bracket,Motor                         |
| 147A   | 5074JJ1005A | Bucket,Dairy                      | 405B   | 5040JJ2001A | Damper,Motor Support                  |
| 147B   | 3390JJ1014A | Tray,Egg                          | 405C   | 5040JA2009B | Damper,Motor Support                  |
| 147C   | 3550JJ1017A | Cover,Bucket                      | 405F   | 5040JA2004B | Damper,Motor Support                  |
| 151A   | 3391JJ1038B | Tray Assembly,Vegetable           | 405G   | 4811JJ2002J | Bracket Assembly,Motor                |
| 151C   | 4940JJ2010A | KNOB,SHUTTER                      | 405H   | 6421JB2002D | Solenoid,Reversing,Valve              |
| 154A   | 3550JJ1108A | Cover,TV                          | 406B   | 6600JB1004A | Switch,Push Button                    |
| 155B   | 4980JJ1016A | SUPPORTER,COVER TV                | 407A   | 5209JJ2004A | Duct Assembly,Connector               |
| 158A   | 3550JJ1104A | Cover,Lamp                        | 407A   | ADJ36834101 | Duct Assembly,Connector               |
| 158E   | MCK30060901 | Cover,Lamp                        | 409B   | 6912JB2004M | Lamp,Incandescent                     |
| 167B   | 4890JL1002H | Shelf,Glass                       | 409D   | 3034JJ1002B | Reflector,Lamp                        |
| 170A   | 3391JJ2018D | Tray Assembly,Meat                | 410A   | 6621JK2003B | Drawing,Assembly                      |
| 200A   | ADC52734104 | Door Assembly,Freezer             | 410G   | 0CZZJB2012K | Capacitor,Electric Appliance Film,Box |
| 201A   | ADD36429904 | Door Foam Assembly,Freezer        | 411A   | 6411JK1006L | Power Cord Assembly                   |
| 203A   | 4987JJ1004Z | Gasket Assembly,Door              | 412D   | 6877JK2011A | Drawing,Assembly                      |
| 207C   | ACW36833904 | Decor Assembly,Case               | 418A   | 5300JB1100J | Heater,Sheath                         |
| 212B   | MEB41753001 | Handle,Freezer                    | 420A   | 4681JB1029J | Motor,DC                              |
| 212G   | 3846JD1007H | Name Plate                        | 501A   | EBR41956101 | PCB Assembly                          |
| 212J   | 4620JJ2010C | STOPPER,HANDLE                    | 501F   | 3551JJ1020A | Cover Assembly,PCB                    |
| 230A   | ADC52734304 | Door Assembly,Refrigerator(Right) | 503D   | 3110JJ1021A | Case,Display                          |
| 230B   | ADC52734204 | Door Assembly,Refrigerator(Left)  | 600A   | AEQ36756907 | Ice Maker Assembly,Kit                |
| 231A   | ADD36429804 | Door Foam Assembly,Refrigerator   | 600B   | AKC37000401 | Bucket Assembly,Ice                   |
| 231B   | ADD36429604 | Door Foam Assembly,Refrigerator   | 603B   | 4931JA3005B | Holder Assembly,Bracket               |
| 233A   | 4987JJ2003N | Gasket Assembly,Door              | 603C   | 4930JA3091A | Holder,Bracket                        |
| 233B   | 4987JJ2003G | Gasket Assembly,Door              | 603C   | 4930JA3091A | Holder,Bracket                        |
| 233D   | ACQ36835602 | Cover Assembly,Front              | 603C   | 4930JA3091A | Holder,Bracket                        |
| 237A   | 4974JJ2017A | Guide,Pitcher                     | 603D   | 4930JA3093A | Holder,Bracket                        |
| 237C   | 4974JJ1021A | Guide,Drawer                      | 606A   | MCK41991601 | Cover,Motor                           |
| 241A   | 3550JJ1103A | Cover,Bucket                      | 610A   | 3550JJ2020A | Cover,Sensor                          |
| 241B   | 5074JJ1019A | Bucket,Dairy                      | 611A   | 5231JA2006A | Filter Assembly,Water                 |
| 241C   | 5005JJ2021E | Basket Assembly,Door              | 611B   | 5230JA2003A | Filter,Head                           |
| 241D   | 5005JJ2022A | Basket Assembly,Door              | 611C   | 3550JL1008E | Cover,Filter                          |
| 241G   | AAP37000301 | Basket Assembly,Door              | 611D   | 3550JJ2028B | Cover,Filter                          |
| 243A   | 4620JJ3006D | Stopper,Door                      | 614A   | 6421JA3001X | Solenoid,Reversing,Valve              |
| 243A   | 4620JJ3006D | Stopper,Door                      | 615A   | 4838JA2003B | Tank,Water                            |
| 243B   | 4620JJ2009A | Stopper,Door                      | 616A   | 5210JA3005X | Tube,Plastic                          |
| 243B   | 4620JJ2009A | Stopper,Door                      | 616D   | 5210JA3004B | Tube,Plastic                          |
| 248E   | 3806JJ1048A | Decor,Tray                        | 616H   | 4932JA3014A | Connector,Tube                        |
| 248F   | 3806JL2011D | Decor,Tray                        | 616J   | MCD38280801 | Connector,Tube                        |
| 249A   | 5098JJ1002B | Connector Assembly                | 616K   | 4932JA2003B | Connector,Tube                        |
| 249B   | 5098JJ1002A | Connector Assembly                | 617A   | 5210JA3005G | Tube,Plastic                          |
| 249E   | 5218JA1010E | Rail,Slide                        | 617B   | 4970JA3004G | Spring                                |
| 249F   | 5218JA1010F | Rail,Slide                        | 619A   | MJX41869201 | Valve,Water                           |
| 249J   | 3550JJ1111A | Cover,Connector                   | 619B   | 3550JJ2024A | Cover,Valve                           |
| 249K   | 3550JJ1111B | Cover,Connector                   | 621B   | ACJ30147004 | Connector Assembly                    |
| 250A   | 4270JJ3001E | Bar                               | 621C   | ACJ30147003 | Connector Assembly                    |
| 250B   | 4403JJ3001A | Connector Assembly                | 623B   | 5006JJ2003A | Cap,Cover                             |
| 250B   | 4403JJ3001A | Connector Assembly                | 623C   | 4930JA3054A | Holder,Pipe                           |
| 262E   | 4350JA3005B | Ring                              | 625A   | 3550JA2184A | Cover,Tube                            |
| 262H   | 4775JJ2019F | Hinge Assembly,Center             | 627A   | 4770JA3001A | Band                                  |
| 271A   | AEH36437001 | Hinge Assembly,Upper              | 630L   | 4970JJ3005A | Spring                                |
| 271C   | AEH36437002 | Hinge Assembly,Upper              | 631A   | MCK41996401 | Cover,Front                           |
| 275A   | ABN52734601 | Cap Assembly,Duct                 | 903A   | 3550JJ0006D | Cover,Lower                           |
| 275B   | 5006JA2012G | Cap,Duct                          | 903B   | 4930JJ2021A | Holder,Cover(Lower)                   |
| 275C   | 5040JA3032A | Cap,Rubber                        | 903D   | 6500JK1003A | Sensor                                |
| 276A   | 4970JA3011C | Spring,Lever                      | 903E   | 6500JK1004A | Sensor                                |
| 276B   | 4930JA3043A | Holder,Lever                      | B01    | 1STZJA3004F | Screw,Customized                      |
| 279D   | 3110JJ1011E | Case,PCB                          | S01    | 1SZZJJ3010A | Screw,Customized                      |
| 281A   | ACQ36833808 | Cover Assembly,Hinge              | S24    | 1SZZJA3011B | Screw,Customized                      |
| 281G   | 3390JJ1039A | Tray,Drain                        | S24    | 1SZZJA3011B | Screw,Customized                      |
| 282B   | 4775JJ2019E | Hinge Assembly,Center             | S27    | 4J01424C    | Screw,Customized                      |
| 282E   | ACQ36833807 | Cover Assembly,Hinge              | S27    | 4J01424C    | Screw,Customized                      |
| 282F   | 3806JL2006H | Decor,Duct                        | S31    | 4J01425D    | Screw,Customized                      |
| 286A   | 4984JJ3003A | BUSH                              | S32    | 3J05696W    | Screw,Customized                      |
| 286A   | 4984JJ3003A | BUSH                              | S38    | 4J00415D    | Screw,Customized                      |
| 301A   | 5421JJ1001B | Evaporator Assembly               | S38    | 4J00415D    | Screw,Customized                      |

## LFX23961SW

| LOC NO | PART NO     | DESCRIPTION                       | LOC NO | PART NO     | DESCRIPTION                           |
|--------|-------------|-----------------------------------|--------|-------------|---------------------------------------|
| 103A   | 3650JJ2003E | Handle,Rear                       | 305B   | 4580JJ3001A | Roller                                |
| 103B   | 3650JJ2003A | Handle,Rear                       | 305C   | 4J04238A    | Pin,Common                            |
| 103C   | 3551JJ1015B | Cover Assembly,Lower              | 305C   | 4J04238A    | Pin,Common                            |
| 103E   | 5218JJ3001A | Rail,Slide                        | 305D   | 4580JA3042A | Roller                                |
| 103E   | 5218JJ3001A | Rail,Slide                        | 307A   | TCA31748001 | Compressor,Set Assembly               |
| 104E   | 4931JJ3002A | Holder Assembly,Gasket            | 308A   | 6748C0004D  | Thermistor Assembly,PTC               |
| 105F   | 5070JJ3002A | Skirt,Lower                       | 309A   | 6750C0004R  | Overload Protect                      |
| 106A   | 4779JA2003A | Leg Assembly,Adjust               | 310A   | 3550JA2059A | Cover,PTC                             |
| 120B   | 5209JJ1002C | Duct Assembly,Multi               | 312A   | 5040JA3031A | Damper,Compressor                     |
| 125D   | 4930JJ3007A | Holder,Bracket                    | 314A   | 4620JA3009A | Stopper,Compressor                    |
| 128A   | 4975JJ2002A | Guide Assembly,Rail               | 315A   | 3103JJ1001J | Base Assembly,Compressor              |
| 128B   | 4975JJ2002B | Guide Assembly,Rail               | 317A   | 5851JJ2002F | Drier Assembly                        |
| 128E   | 4930JJ1025A | Holder,Rail                       | 318A   | 4930JA3034A | Holder,Drier                          |
| 128F   | 4930JJ1025B | Holder,Rail                       | 319A   | 3390JJ0004A | Tray,Drip                             |
| 131A   | MKK42003201 | Bucket,Ice                        | 319C   | MEA41997401 | Guide,Fan                             |
| 136A   | 3391JJ1011B | Tray Assembly,Drawer              | 319E   | 4810JJ2005A | Bracket,Motor                         |
| 136B   | MJS42003601 | Tray,Drawer                       | 323B   | 5403JJ1007A | Condenser Assembly,Wire               |
| 140B   | 5027JJ2007B | Shelf Assembly,Refrigerator       | 327A   | 5006JA3034A | Cap,Drain Tube                        |
| 140B   | 5027JJ2007B | Shelf Assembly,Refrigerator       | 328B   | 4J04328A    | Damper,Pipe                           |
| 140D   | MHL38615403 | Shelf,Net                         | 329A   | 5901JJ1005A | Fan Assembly                          |
| 140E   | MHL38615404 | Shelf,Net                         | 329C   | ADP36665702 | Fan Assembly                          |
| 142D   | 5026JJ2001L | Shelf,Net                         | 332A   | AEB36834001 | Grille Assembly,Fan                   |
| 142E   | 5026JJ2001M | Shelf,Net                         | 401A   | 6615JB2005C | Controller Assembly                   |
| 143E   | 5027JJ1008K | Shelf Assembly,Refrigerator       | 402A   | 6600JB3007A | Switch,Push Button                    |
| 143F   | 5027JJ1008D | Shelf Assembly,Refrigerator       | 402A   | 6600JB3007A | Switch,Push Button                    |
| 145A   | 4930JJ2003A | Holder,Shelf                      | 404A   | EAU52096201 | Motor,DC                              |
| 145B   | 4930JJ2004A | Holder,Shelf                      | 405A   | 4810JJ0001A | Bracket,Motor                         |
| 145C   | 4975JJ2028C | Guide Assembly,Rail               | 405B   | 5040JJ2001A | Damper,Motor Support                  |
| 145F   | 4975JJ2028D | Guide Assembly,Rail               | 405C   | 5040JA2009B | Damper,Motor Support                  |
| 147A   | 5074JJ1005A | Bucket,Dairy                      | 405F   | 5040JA2004B | Damper,Motor Support                  |
| 147B   | 3390JJ1014A | Tray,Egg                          | 405G   | 4811JJ2002J | Bracket Assembly,Motor                |
| 147C   | 3550JJ1017A | Cover,Bucket                      | 405H   | 6421JB2002D | Solenoid,Reversing,Valve              |
| 151A   | 3391JJ1038B | Tray Assembly,Vegetable           | 406B   | 6600JB1004A | Switch,Push Button                    |
| 151C   | 4940JJ2010A | KNOB,SHUTTER                      | 407A   | 5209JJ2004A | Duct Assembly,Connector               |
| 154A   | 3550JJ1108A | Cover,TV                          | 407A   | ADJ36834101 | Duct Assembly,Connector               |
| 155B   | 4980JJ1016A | SUPPORTER,COVER TV                | 409B   | 6912JB2004M | Lamp,Incandescent                     |
| 158A   | 3550JJ1104A | Cover,Lamp                        | 409D   | 3034JJ1002B | Reflector,Lamp                        |
| 158E   | MCK30060901 | Cover,Lamp                        | 410A   | 6621JK2003B | Drawing,Assembly                      |
| 167B   | 4890JL1002H | Shelf,Glass                       | 410G   | 0CZZJB2012K | Capacitor,Electric Appliance Film,Box |
| 170A   | 3391JJ2018D | Tray Assembly,Meat                | 411A   | 6411JK1006L | Power Cord Assembly                   |
| 200A   | ADC52734101 | Door Assembly,Freezer             | 412D   | 6877JK2011A | Drawing,Assembly                      |
| 201A   | ADD36429901 | Door Foam Assembly,Freezer        | 418A   | 5300JB1100J | Heater,Sheath                         |
| 203A   | 4987JJ1004A | Gasket Assembly,Door              | 420A   | 4681JB1029J | Motor,DC                              |
| 207C   | ACW36833901 | Decor Assembly,Case               | 501A   | EBR41956101 | PCB Assembly                          |
| 212B   | MEB41753003 | Handle,Freezer                    | 501F   | 3551JJ1020A | Cover Assembly,PCB                    |
| 212G   | 3846JD1007F | Name Plate                        | 503D   | 3110JJ1021A | Case,Display                          |
| 212J   | 4620JJ2010C | STOPPER,HANDLE                    | 600A   | AEQ36756907 | Ice Maker Assembly,Kit                |
| 230A   | ADC52734301 | Door Assembly,Refrigerator(Right) | 600B   | AKC37000401 | Bucket Assembly,Ice                   |
| 230B   | ADC52734201 | Door Assembly,Refrigerator(Left)  | 603B   | 4931JA3005B | Holder Assembly,Bracket               |
| 231A   | ADD36429801 | Door Foam Assembly,Refrigerator   | 603C   | 4930JA3091A | Holder,Bracket                        |
| 231B   | ADD36429601 | Door Foam Assembly,Refrigerator   | 603C   | 4930JA3091A | Holder,Bracket                        |
| 233A   | 4987JJ2003E | Gasket Assembly,Door              | 603C   | 4930JA3091A | Holder,Bracket                        |
| 233B   | 4987JJ2003G | Gasket Assembly,Door              | 603D   | 4930JA3093A | Holder,Bracket                        |
| 233C   | ACQ36835601 | Cover Assembly,Front              | 606A   | MCK41991601 | Cover,Motor                           |
| 233D   | ACQ36835602 | Cover Assembly,Front              | 610A   | 3550JJ2020A | Cover,Sensor                          |
| 237A   | 4974JJ2017A | Guide,Pitcher                     | 611A   | 5231JA2006A | Filter Assembly,Water                 |
| 237C   | 4974JJ1021A | Guide,Drawer                      | 611B   | 5230JA2003A | Filter,Head                           |
| 241A   | 3550JJ1103A | Cover,Bucket                      | 611C   | 3550JL1008E | Cover,Filter                          |
| 241B   | 5074JJ1019A | Bucket,Dairy                      | 611D   | 3550JJ2028B | Cover,Filter                          |
| 241C   | 5005JJ2021E | Basket Assembly,Door              | 614A   | 6421JA3001X | Solenoid,Reversing,Valve              |
| 241D   | 5005JJ2022A | Basket Assembly,Door              | 615A   | 4838JA2003B | Tank,Water                            |
| 241G   | AAP37000301 | Basket Assembly,Door              | 616A   | 5210JA3005X | Tube,Plastic                          |
| 243A   | 4620JJ3006A | Stopper,Door                      | 616D   | 5210JA3004B | Tube,Plastic                          |
| 243A   | 4620JJ3006A | Stopper,Door                      | 616H   | 4932JA3014A | Connector,Tube                        |
| 243B   | 4620JJ2009A | Stopper,Door                      | 616J   | MCD38280801 | Connector,Tube                        |
| 243B   | 4620JJ2009A | Stopper,Door                      | 616K   | 4932JA2003B | Connector,Tube                        |
| 248E   | 3806JL1048A | Decor,Tray                        | 617A   | 5210JA3005G | Tube,Plastic                          |
| 248F   | 3806JL2011D | Decor,Tray                        | 617B   | 4970JA3004G | Spring                                |
| 249A   | 5098JJ1002B | Connector Assembly                | 619A   | MJX41869201 | Valve,Water                           |
| 249B   | 5098JJ1002A | Connector Assembly                | 619B   | 3550JJ2024A | Cover,Valve                           |
| 249E   | 5218JA1010E | Rail,Slide                        | 621B   | ACJ30147004 | Connector Assembly                    |
| 249F   | 5218JA1010F | Rail,Slide                        | 621C   | ACJ30147003 | Connector Assembly                    |
| 249J   | 3550JJ1111A | Cover,Connector                   | 623B   | 5006JJ2003A | Cap,Cover                             |
| 249K   | 3550JJ1111B | Cover,Connector                   | 623C   | 4930JA3054A | Holder,Pipe                           |
| 250A   | 4270JJ3001E | Bar                               | 625A   | 3550JA2184A | Cover,Tube                            |
| 250B   | 4403JJ3001A | Connector Assembly                | 627A   | 4770JA3001A | Band                                  |
| 250B   | 4403JJ3001A | Connector Assembly                | 630A   | 3581JA1182F | Door Assembly,Freeze Room             |
| 262E   | 4350JA3005B | Ring                              | 630F   | AEH36582801 | Hinge Assembly,Upper                  |
| 262H   | 4775JJ2019B | Hinge Assembly,Center             | 630G   | AEH36582701 | Hinge Assembly,Lower                  |
| 271A   | AEH36437001 | Hinge Assembly,Upper              | 630H   | MCK42523301 | Cover,Home Bar                        |
| 271C   | AEH36437002 | Hinge Assembly,Upper              | 630K   | 4970JA3004G | Spring                                |
| 275A   | ABN52734601 | Cap Assembly,Duct                 | 630L   | 4970JJ3005A | Spring                                |
| 275B   | 5006JA2012G | Cap,Duct                          | 631A   | MCK41996401 | Cover,Front                           |
| 275C   | 5040JA3032A | Cap,Rubber                        | 903A   | 3550JJ0006A | Cover,Lower                           |
| 276A   | 4970JA3011C | Spring,Lever                      | 903B   | 4930JJ2021A | Holder,Cover(Lower)                   |
| 276B   | 4930JA3043A | Holder,Lever                      | 903D   | 6500JK1003A | Sensor                                |
| 279D   | 3110JJ1011E | Case,PCB                          | 903E   | 6500JK1004A | Sensor                                |
| 281A   | ACQ36833802 | Cover Assembly,Hinge              | B01    | 1STZJA3004F | Screw,Customized                      |
| 281G   | 3390JJ1039A | Tray,Drain                        | S01    | 1SZZJJ3010A | Screw,Customized                      |
| 282B   | 4775JJ2019A | Hinge Assembly,Center             | S24    | 1SZZJA3011B | Screw,Customized                      |
| 282E   | ACQ36833801 | Cover Assembly,Hinge              | S24    | 1SZZJA3011B | Screw,Customized                      |
| 282F   | 3806JL2006H | Decor,Duct                        | S27    | 4J01424C    | Screw,Customized                      |
| 286A   | 4984JJ3003A | BUSH                              | S27    | 4J01424C    | Screw,Customized                      |
| 286A   | 4984JJ3003A | BUSH                              | S31    | 4J01425D    | Screw,Customized                      |
| 301A   | 5421JJ1001B | Evaporator Assembly               | S32    | 3J05696W    | Screw,Customized                      |
| 304A   | 3551JJ2008B | Cover Assembly,Machinery(Rear)    | S38    | 4J00415D    | Screw,Customized                      |
| 305B   | 4580JJ3001A | Roller                            | S38    | 4J00415D    | Screw,Customized                      |



MARCH, 2008