

This Owner's Manual is provided and hosted by Appliance Factory Parts.

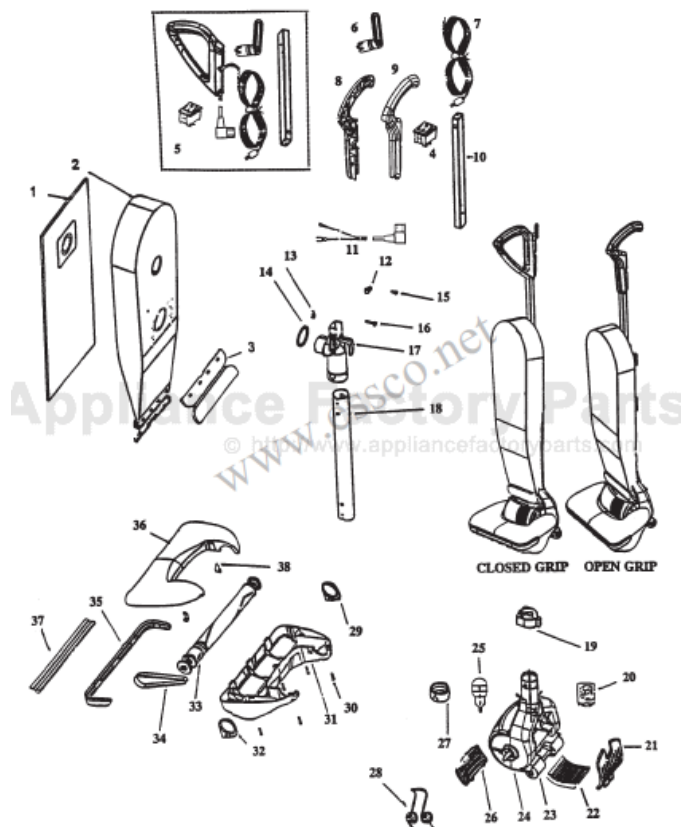

Bissell Prolite 3560 Owner's Manual

[Shop genuine replacement parts for Bissell Prolite
3560](#)



[Find Your Bissell Vacuum Cleaner Parts - Select From 376 Models](#)

----- Manual continues below -----



ProLite®

USER'S GUIDE

3560 SERIES

3 Safety Instructions

4 Product View

4-7 Assembly/Accessories

7 Operations / Special Tools

8-10 Routine Maintenance

11 Troubleshooting

11 Replacement Parts

12 Warranty

12 Consumer Services



Thanks for buying a BISSELL Lightweight Upright Vacuum Cleaner

We're glad you purchased a BISSELL Lightweight Upright Vacuum Cleaner. Everything we know about floor care went into the design and construction of this powerful, high-tech home vacuuming system.

Your BISSELL Prolite® Vacuum Cleaner is well made, and we back it with a comprehensive 10-year warranty on the motor housing and 5-year warranty on the motor. We also stand behind it with a knowledgeable, dedicated Consumer Services department, so, should you ever have a problem, you'll receive fast, considerate assistance.

My great-grandfather invented the floor sweeper in 1876. Today, BISSELL is a global leader in the design, manufacture, and service of high quality homecare products like your BISSELL Prolite Lightweight Upright Vacuum Cleaner.

Thanks again, from all of us at BISSELL.

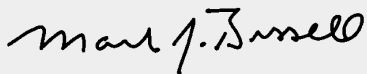

Mark J. Bissell
President and Chief Executive Officer

IMPORTANT SAFETY INSTRUCTIONS

When using an electrical appliance, basic precautions should be observed, including the following:

READ ALL INSTRUCTIONS BEFORE USING YOUR PRODUCT NAME HERE.

⚠ WARNING: To reduce the risk of fire, electric shock, or injury:

- Always connect to a polarized outlet (left slot is wider than right). Do not modify the polarized plug to fit a non-polarized outlet or extension cord.
- Do not leave vacuum cleaner when it is plugged in. Unplug from outlet when not in use and before servicing.
- Do not use outdoors or on wet surfaces.
- Do not allow to be used as a toy. Close attention is necessary when used by or near children.
- Do not use for any purpose other than described in this User's Guide. Use only manufacturer's recommended attachments.
- Do not use with damaged cord or plug. If appliance is not working as it should, has been dropped, damaged, left outdoors, or dropped into water, return it to a service center.
- Do not pull or carry by cord, use cord as a handle, close a door on cord, or pull cord around sharp edges or corners. Do not run appliance over cord. Keep cord away from heated surfaces.
- Do not unplug by pulling on cord. To unplug, grasp the plug, not the cord.
- Do not handle plug or vacuum cleaner with wet hands.
- Do not put any object into openings. Do not use with any opening blocked; keep openings free of dust, lint, hair, and anything that may reduce air flow.
- Keep hair, loose clothing, fingers, and all parts of body away from openings and moving parts.
- Turn off all controls before plugging or unplugging vacuum cleaner.

- Use extra care when cleaning on stairs.
- Do not use to pick up flammable or combustible materials (lighter fluid, gasoline, kerosine, etc.) or use in areas where they may be present.
- Do not use vacuum cleaner in an enclosed space filled with vapors given off by oil base paint, paint thinner, some moth proofing substances, flammable dust, or other explosive or toxic vapors.
- Do not use to pick up toxic material (chlorine bleach, ammonia, drain cleaner, etc.).
- Do not pick up anything that is burning or smoking, such as cigarettes, matches, or hot ashes.
- Do not use without dust bag and/or filters in place.
- Do not pick up hard or sharp objects such as glass, nails, screws, coins, etc.
- Use only on dry, indoor surfaces.
- Keep appliance on a level surface.
- Do not carry the vacuum cleaner while it is running.

SAVE THESE INSTRUCTIONS FOR FUTURE USE.

THIS MODEL IS FOR HOUSEHOLD USE ONLY.

THIS APPLIANCE HAS A POLARIZED PLUG.

To reduce the risk of electric shock, this appliance has a polarized plug (one blade is wider than the other). This plug will fit in a polarized outlet only one way. If the plug does not fit fully in the outlet, reverse the plug. If it still does not fit, contact a qualified electrician to install a proper outlet. Do not change the plug in any way.

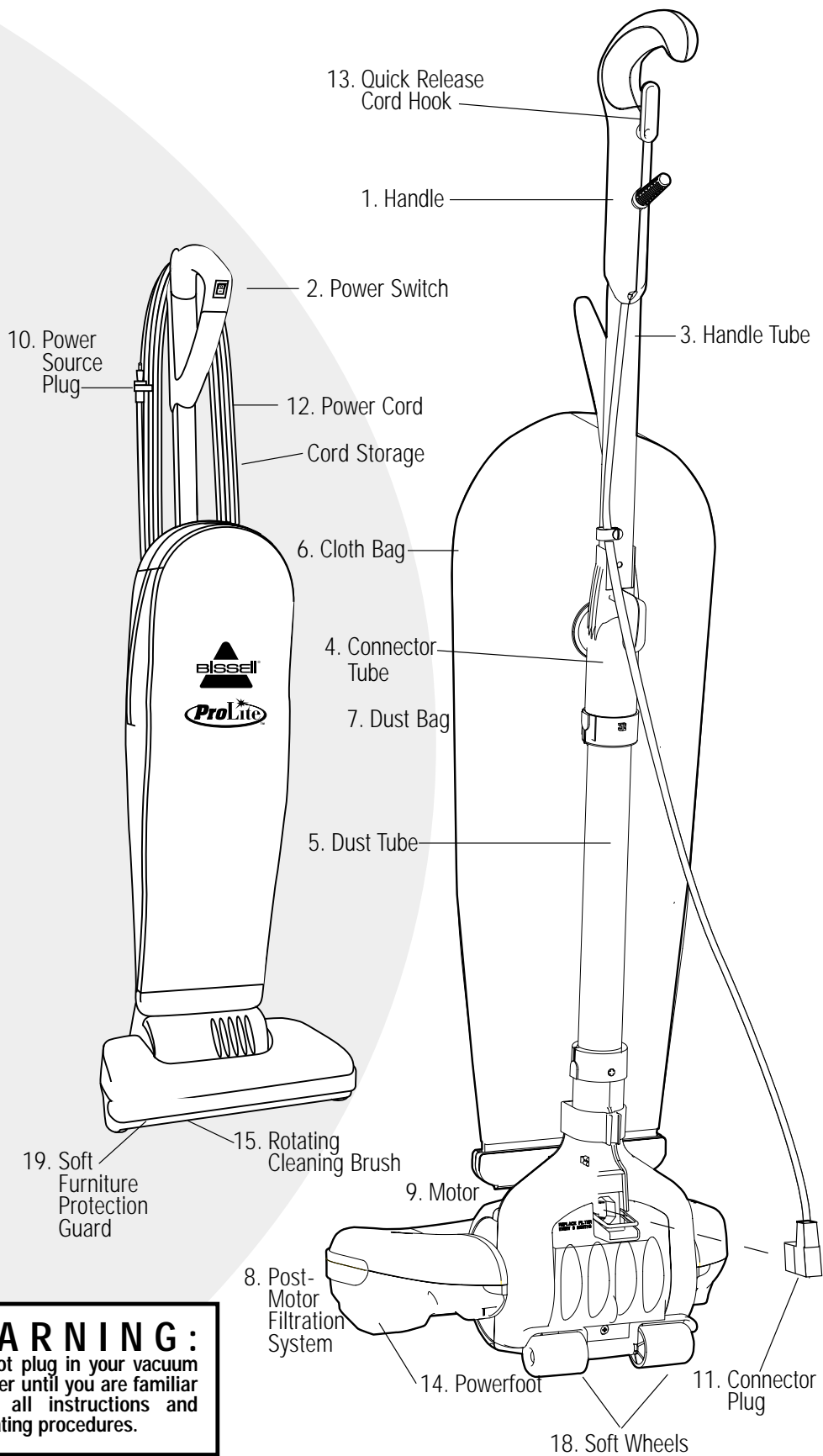

⚠ WARNING:
 Do not plug in your vacuum cleaner until you are familiar with all instructions and operating procedures.

How To Use This Guide

This User's Guide is designed to help you gain the best performance from your BISSELL® Lightweight Upright Vacuum Cleaner. Inside you will find assembly and operating instructions, safety precautions, and maintenance and troubleshooting instructions. Please read through this Guide thoroughly before assembling and using your vacuum cleaner.

Refer to the Product Diagram in this section to locate and familiarize yourself with its parts and features. This will be helpful in assembling the unit and in finding the proper location of parts when you perform routine maintenance. Additional diagrams are included in the maintenance and troubleshooting sections to simplify those tasks.

How To Assemble

The ProLite is packaged for convenience and requires minimal assembly. The only tool you will need is a Phillips head screwdriver.

1. Slide the Handle Tube into the Connector, aligning the hole in the Handle Tube with the molded hole at the top of the Connector.
2. Hold the hex nut in front of the connector in the hex shaped cavity while inserting the screw with your finger from the back. Tighten while placing your finger over the hex cavity to hold the hex nut in place. After a few turns, tighten further with a Phillips head screwdriver. Do not overtighten.
3. Slide screw through plastic retainer from the inside, and bag. Slide spacer onto screw and line up with hole in Handle Tube. Tighten screw.
4. Remove screw from filter cover. Remove filter cover. Insert the Connector Plug into the back of the unit at the rear of the Powerfoot—make sure it is fully inserted. Replace filter cover. Replace filter cover screw.

Your vacuum cleaner is now ready to use.

⚠ WARNING :
Plastic bags or film can be dangerous. To avoid danger of suffocation, keep away from babies and children.

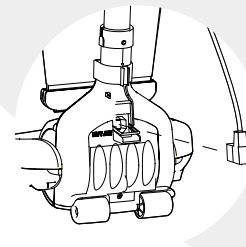
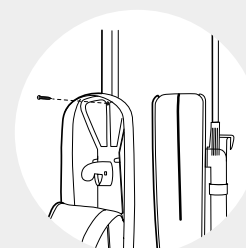
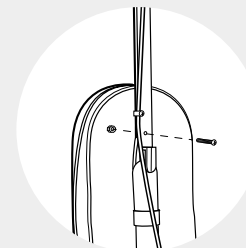
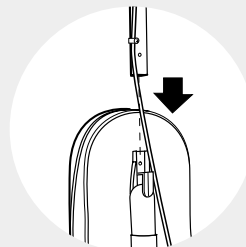

Product Features and Advantages

The BISSELL® ProLite® Lightweight Upright Vacuum Cleaner is a lightweight, yet powerful, cleaning system ideal for household use on all types of carpets and floors.

1. Handle - soft grip designed for comfort and easy maneuvering.
2. Power Switch - conveniently located in handle.
3. Handle Tube - lightweight, for easy movement and use.
4. Connector Tube.
5. Dust Tube - large diameter dust tube designed to minimize clogging.
6. Cloth Bag - durable, reinforced material for years of service.
7. Dust Bag - The ProLite dust bag is made of HEPA material for highest efficiency against problem allergens like dust mite waste, pet dander and pollen.
8. The Filtrete™ Post-Motor Filter, when combined with the HEPA Filtrete™ bag is a patented filtration system by 3M. The filter helps to reduce emissions into the air.
9. Motor - 6 amps of full cleaning power, saves energy.
10. Power Source Plug - polarized for safe, reliable operation.
11. Connector Plug - for enhanced safety.
12. Power Cord - 30 foot Heavy-Duty, Commercial Quality for extended reach.
13. Quick Release Cord Hook - for quick, easy removal of power cord.
14. Powerfoot - twin fan/dual suction design for removing deeply embedded dirt; wide cleaning path for fast pickup and superior edge cleaning.
15. Rotating Cleaning Brush - continuous, rotating dual action for thorough cleaning; white, non-marring bristles.
16. Pivoting Headlight - powerful beam makes it easier to see.
17. Hair Cutter - ensures that any long hair or other fibers are cut and broken down into lengths that are manageable for the vacuum. This helps to prevent clogs.

Product Features and Advantages

18. Soft Wheels - Soft material is easy on bare floors.
19. Soft Furniture Protection Guard.
20. Screw & Spacer.

How To Use Your BISSELL Vacuum

Power Supply

The Power Cord is stored at the back of the vacuum cleaner, and is looped around the upper and lower cord hooks. The polarized Power Plug is designed to attach to the cord during storage. Before using, make sure the Connector Plug is securely attached to the Powerfoot and that the Power Source Plug is plugged into a polarized outlet.

Power Switch

The Power Switch is located in the Handle of the cleaner. Push down (I) to turn on. Push (O) to turn off.

Operation

The ProLite® is designed to handle all types of basic household floor cleaning needs. It can be used on all types of carpeting. It also effectively and safely cleans wood, linoleum and vinyl floors. Its wide Powerfoot makes cleaning quick and easy.

To place the ProLite® in position for use, lightly press your foot on the Powerfoot and tip back the handle. When the ProLite® is in this position, the headlight will automatically become visible and turn on.

Power Cord Storage

When you are finished using your ProLite, return it to the upright position. Make sure the machine is turned OFF (O). Always unplug the unit by grasping the Power Plug (NOT the cord) and disconnecting from the outlet. Properly store the Power Cord by winding the cord around the cord hooks at the back of the machine in a continuous loop. Attach the Power Plug to the cord to secure.

Tip:

Before cleaning under low furniture, check area first for objects that might harm the rotating floor brush or get caught in the Dust Tube.

Tip:

Your BISSELL® Lightweight Upright Vacuum Features a Quick Release Cord Hook that allows you to remove the Power Cord quickly and easily. Just rotate the Hook towards the floor and remove the cord.

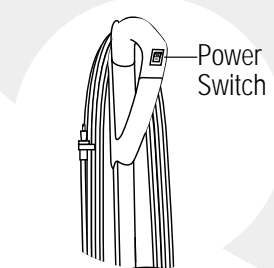
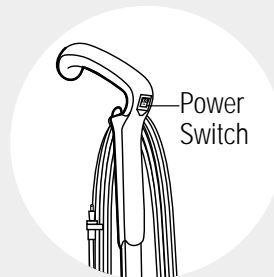
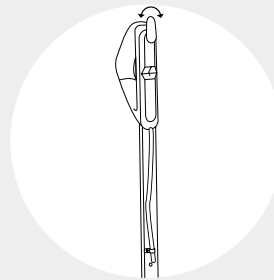

Routine Maintenance

For maximum performance from your BISSELL® ProLite® Lightweight Upright vacuum cleaner, it is recommended you perform these simple maintenance checks.

Replacing the Dust Bag

The Dust Bag should be checked weekly. It should be replaced when it is near full or when cleaning suction diminishes. **Never reuse a Vacuum Bag.**

1. Unplug vacuum.
2. Unzip cloth Bag. Remove Collar Retainer by pressing on the two tabs and then pull the top towards you. Slide Dust Bag collar up and out of retainer. Dispose of Dust Bag.
3. Slide collar of new Dust Bag completely into Collar Retainer.
4. Push Collar Retainer back into position and secure in place.
5. Tuck the remainder of the Dust Bag completely inside the cloth Bag. Make sure it lays flat, top to bottom, without bunching. Zip cloth Dust Bag.

Replacement Bag: BISSELL® Style 6 Filtrete™ HEPA Bags (#32052, package of 3).

Cleaning the Dust Tube

The ProLite® features a wide diameter Dust Tube designed to optimize cleaning power. For best performance it should be routinely checked and cleared of excess dust and other debris.

Note: It is recommended the tube be cleaned on a bare floor, or with some newspaper to cover the floor, to catch any loose material or dust removed during cleaning.

1. Release Bag Tension Spring.
2. Unplug Connector Plug.
3. Locate the Tube Release Button at the top of the Powerfoot. The button is hidden under a rubber collar. The button can be pressed through the rubber collar to release the tube. Lift off the tube while pressing on the rubber collar.
4. Use a wire brush to clean out the inside of the tube and the top section of the Powerfoot where the tube connects.

⚠ WARNING: To reduce the risk of electric shock, turn Power Switch OFF and disconnect polarized plug from electrical outlet before performing maintenance or troubleshooting checks.

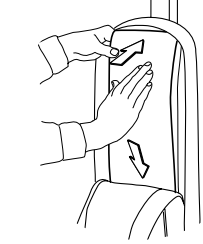
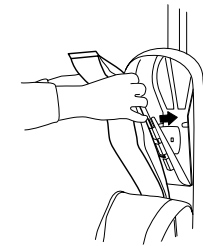
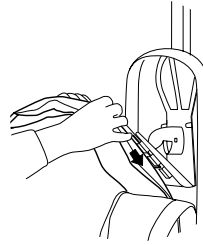

Tip:

Vacuum new carpet or vacuuming fine powders may clog the Dust Bag. So check the bag more often

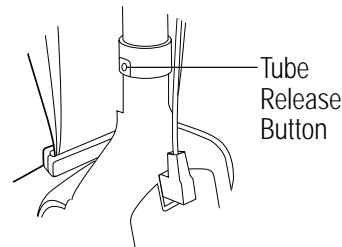
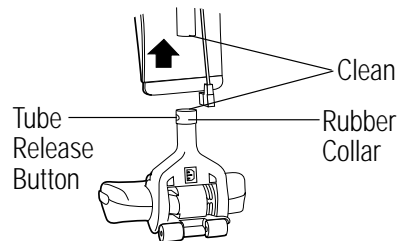

Cleaning the Dust Tube

5. Reconnect the tube with the Powerfoot. It should snap into place.
6. Plug the Connector Plug back into base of vacuum.

BISSELL Consumer Services

1-800-237-7691

Monday - Friday 8 a.m. — 9 p.m. EST

Saturday 9 a.m. — 5 p.m. EST

Or visit our Website - www.bissell.com

Replacing the Filter

The 3M Filtrete™ Filter is located in the Powerfoot of your vacuum cleaner. Combined with the Filtrete HEPA Dust Bag, it is designed to promote optimum cleaning efficiency, as well as the removal of dust and allergens. It should be regularly checked, and changed when the filter becomes dirty. If the filter appears excessively dirty, more frequent replacement is recommended.

⚠ WARNING :
To reduce the risk of injury from moving parts turn off vacuum cleaner and disconnect Power Source Plug from electrical outlet.

1. To replace filter, remove the screw with a Phillips head screwdriver.
2. Lift out filter frame.
3. Remove filter and empty into trash.
4. Replace with new Filtrete Style 6 filter by 3M.
5. Replace filter frame by sliding in the two tabs at the top of the frame and centering over the screw hole.
6. Replace screw.

Replacing the Light Bulb

1. Make sure vacuum cleaner is unplugged.
2. Insert the tip of blade type screwdriver at either of the connector tabs at the bottom of the headlight lens. Pry gently to remove the lens.
3. Remove old bulb.
4. Push new bulb into place.
5. Reinstall lens.

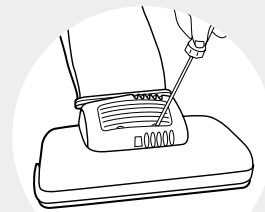

Checking the Rotating Brush and Drive Belt

The brush and drive belt should both regularly be checked for wear or damage. You should also keep the brush and brush ends free of string, hair, and carpet fibers as these can become entangled in the brush and reduce its cleaning effectiveness.

Cleaning the Brush/Replacing the Drive Belt

NOTE: The brush can most often be cleaned without removal from the vacuum. If there is an excessive amount of hair and debris, however, it is best to remove the brush.

1. Unplug the vacuum. Tip unit over, face down, on a flat surface.
2. Remove all 3 screws from the bottom of the Powerfoot.
3. Grip both the top cover and base while turning unit back over. Lift off top cover.
4. Check Belt. If it is broken or damaged, Brush Roll needs to be removed before replacing a new belt.
5. To remove the Brush Roll, pull the right side of the Brush Roll toward the front of the Powerfoot as you lift slowly.
6. Clean off brush roll as necessary.
7. Place existing or new Belt over Brush Roll Pulley and the Motor Shaft. Insert the End Cap Pin on the left of the Brush Roll into the slot on the Powerfoot and slide the End Cap Pin on the right end of the Brush Roll in to the slot in the Powerfoot and lower until it clicks into place.
8. Make sure the Furniture Protection Guard is still intact.
9. Align the 3 tabs on the top cover with the 3 slots in the Powerfoot. Press into place, making sure the Furniture Protection Guard is on the outside.
10. Turn vacuum cleaner back face down.
11. Replace the 3 screws.

Note: It may be easier to begin with the center screw.

Replacement Belt: BISSELL® Replacement Belt Style 6 (#32053, package of 2).

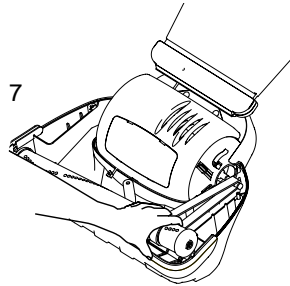
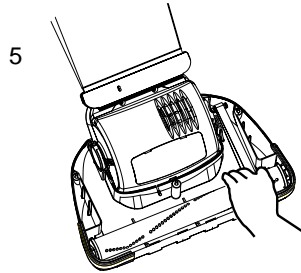
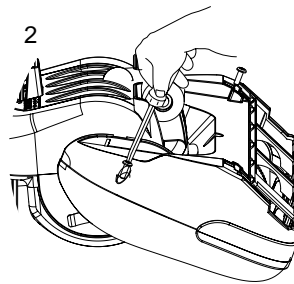
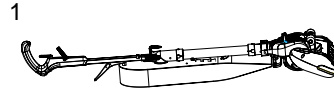

Troubleshooting

Vacuum cleaner won't run.

Possible Causes

- 1 Vacuum Cleaner is not plugged in
- 2 Household fuse/circuit breaker tripped

Vacuum cleaner won't pick up dirt.

Possible Causes

- 1 Dust Bag is full
- 2 Rotating Brush Drive Belt
- 3 Rotating Floor Brush bristles worn
- 4 Rotating Floor Brush Jammed
- 5 Air passageway clogged
- 6 Vacuum Tube is clogged

Accumulation of dust inside Cloth Bag

Possible Cause

- 1 Dust Bag is clogged or dirty
- 2 Dust Bag Retainer not closed
- 3 Clog at inlet

Remedies

- 1 Check electrical plug
Check electrical cord connection on back of vacuum
- 2 Check/replace fuse - Reset breaker

Remedies

- 1 Replace with new Bag
- 2 Realign Belt; if broken replace
- 3 Replace Brush
- 4 Remove brush and clean debris from Brush Ends; replace Belt
- 5 See "Cleaning the Dust Tube" from passageway
- 6 Clean tube - see instructions on page 8

Remedies

- 1 Replace Dust Bag
- 2 Engage snaps
- 3 Shake dust down to bottom of Bag

WARNING:

To reduce the risk of injury from moving parts and/ or electrical shock, turn Power Switch OFF and disconnect polarized plug from electrical outlet before performing troubleshooting checks.

Replacement Parts

Item	Part No.	Part Name
1	32053	Drive Belt (2-Pack)
2	32062	Micro Filtration Bags (3-Pack)
3	32054	Filtrete™ Filter (2-Pack)
4	G.E.921	Replacement Light Bulb

If suggested solutions for this or any function of the Cleaner do not correct the problem, call:

BISSELL Consumer Services

1-800-237-7691

Monday - Friday 8 a.m. — 9 p.m. EST

Saturday 9 a.m. — 5 p.m. EST

Or visit our website @ www.bissell.com

Please have your model and part numbers of unit ready.

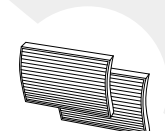
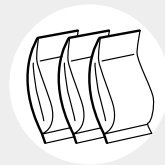

Warranty

This warranty gives you specific legal rights, and you may also have other rights which may vary from state to state. If you need additional instruction regarding this warranty or have questions regarding what it may cover, please contact BISSELL Consumer Services by E-mail, telephone, or regular mail as described below.

Full Three-Year Warranty on BISSELL® ProLite® Vacuum Parts

BISSELL Inc., upon receipt of the product, will repair (with new or remanufactured components), or if repair is not possible after a reasonable number of attempts, either replace (with new or remanufactured product) your ProLite Vacuum, or refund the purchase price, whichever you prefer, free of charge, for **THREE YEARS** from the date of purchase— **any** defective or malfunctioning part.

This warranty applies to product used for personal, and not commercial or rental service. This warranty does not apply to routine maintenance components such as filters, bags, or brushes. Damage or malfunction caused by negligence, abuse, neglect, unauthorized repair, or any other use not in accordance with the User's Guide is not covered. See information below on "How to obtain service for Your BISSELL product for Service".

Limited Warranty On BISSELL® ProLite® Vacuum Motor Housing

Subject to the *EXCEPTIONS AND EXCLUSIONS identified below, BISSELL will repair or replace, (with new or remanufactured components or product) at BISSELL's option, free of charge, from date of purchase by the original purchaser, for:

Five (5) Years – a defective or malfunctioning **Motor**.

Ten (10) Years – a defective or malfunctioning **Motor Housing**.

This warranty applies to product used for personal, and not commercial or rental service. This warranty does not apply to routine maintenance components such as filters, bags, or brushes. Damage or malfunction caused by negligence, abuse, neglect, unauthorized repair, or any other use not in accordance with the User's Guide is not covered. See information below on "How to obtain service for Your BISSELL product for Service".

*EXCEPTIONS AND EXCLUSIONS FROM THE TERMS OF THE LIMITED WARRANTY

THIS WARRANTY IS EXCLUSIVE AND IN LIEU OF ANY OTHER WARRANTIES EITHER ORAL OR WRITTEN ON THE BISSELL® PROLITE® VACUUM MOTOR AND HOUSING. ANY IMPLIED WARRANTIES WHICH MAY ARISE BY OPERATION OF LAW, INCLUDING THE IMPLIED WARRANTIES OF MERCHANTABILITY AND FITNESS FOR A PARTICULAR PURPOSE, ARE LIMITED TO THE THREE-YEAR DURATION FROM THE DATE OF PURCHASE AS DESCRIBED ABOVE.

Some States do not allow limitations on how long an implied warranty lasts, so the above limitation may not apply to you.

If your BISSELL product should require service:

Call BISSELL Consumer Service at 1-800-237-7691 and we will give you the name and address of an authorized BISSELL Service Center in your area. If there is not an authorized BISSELL Service Center in your area, one of our Service Representatives will be happy to assist you. You can also visit the BISSELL website - www.bissell.com to locate a Service Center near you.

For information about repairs or replacement parts, or questions about your warranty, call:

BISSELL Consumer Services

1-800-237-7691

BISSELL Consumer Services

1-800-237-7691

Monday - Friday 8 a.m. — 9 p.m. EST

Saturday 9 a.m. — 5 p.m. EST

Or visit our website @ www.bissell.com

When contacting BISSELL, have model number of unit available.

Please record your Model Number: _____

Please record your Purchase Date: _____

NOTE: Please keep your original sales receipt. It is your warranty.

It is suggested you staple your original sales receipt to the front of this guide.



©2001 BISSELL Homecare Inc
Grand Rapids, Michigan
All rights reserved. Printed in USA.
Part Number 010-6059
Rev 3/02

Visit our website at:
www.bissell.com