

EUREKA

HOME CLEANING SYSTEM and CANISTER VACUUM CLEANER

Household Type

Owner's Guide 6700-6800 Series

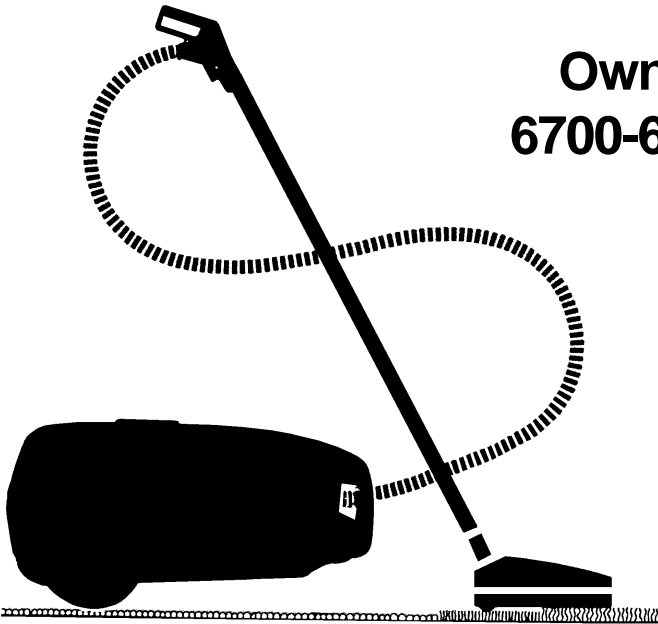

www.eureka.com

For location of nearest
Eureka Warranty Station
or Service Information call
1-800-282-2886.

Index

Important Safeguards	2
Service Information	4
Assembly & Use 6750-6799 ...	5
Assembly & Use 6820-6899 ...	6
Order Form	Insert
Dust Bag & Filter	11
Disposable Dust Bag	12
Brush Roll & Belt	13
Light Bulb	13
Warranty	14-15

IMPORTANT SAFEGUARDS

When using an electrical appliance, basic precautions should always be followed, including the following:

READ ALL INSTRUCTIONS BEFORE USING THIS VACUUM CLEANER.

WARNING

To reduce the risk of fire, electric shock, or injury:

- Do not use outdoors or on wet surfaces.
- Do not leave vacuum cleaner when plugged in. Turn off the switch and unplug the electrical cord when not in use and before servicing.
- Do not allow to be used as a toy. Close attention is necessary when used by or near children.
- Use only as described in this manual. Use only manufacturer's recommended attachments.
- The hose contains electrical wires. Do not use if damaged, cut, or punctured. Avoid picking up sharp objects.
- Always turn off this appliance before connecting or disconnecting either hose or motorized nozzle.
- Do not use with damaged cord or plug. If vacuum cleaner is not working as it should, has been dropped, damaged, left outdoors, or dropped into water, return it to a service center before using.
- Do not pull or carry by cord, use cord as a handle, close door on cord, or pull cord around sharp edges or corners. Do not run vacuum cleaner over cord. Keep cord away from heated surfaces.
- Do not use extension cords or outlets with inadequate current carrying capacity.
- Turn off all controls before unplugging.
- Do not unplug by pulling on cord. To unplug, grasp the plug, not the cord.
- Do not handle plug or vacuum cleaner with wet hands.
- Hold plug when rewinding onto cord reel. Do not allow plug to whip when rewinding.
- Do not put any object into openings. Do not use with any opening blocked; keep free of dust, lint, hair, and anything that may reduce airflow.
- This vacuum cleaner creates suction and contains a revolving brush roll. Keep hair, loose clothing, fingers, and all parts of body away from openings and moving parts.
- Do not pick up anything that is burning or smoking, such as cigarettes, matches or hot ashes.
- Do not use without dust bag or filter(s) in place.
- Belt pulleys can become hot during normal use. To prevent burns, avoid touching the belt pulley when servicing the drive belt.
- Use extra care when cleaning on stairs.
- Do not use to pick up flammable or combustible liquids such as gasoline, or use in areas where they may be present.
- Store your cleaner indoors in a cool, dry area.
- Keep your work area well lighted.
- Unplug electrical appliances before vacuuming them.

SAVE THESE INSTRUCTIONS

CONSEILS DE SÉCURITÉ

Lors de l'utilisation d'un appareil électrique, quelques précautions élémentaires doivent être observées, incluant les suivantes:

LISEZ TOUTES LES INSTRUCTIONS AVANT D'UTILISER VOTRE ASPIRATEUR.

AVERTISSEMENT

Pour réduire le risque de feu, de choc électrique, ou de blessure:

- Ne pas utiliser à l'extérieur ou sur des surfaces mouillées.
- Fermez le commutateur et débranchez l'appareil lorsque vous ne l'utilisez pas ou avant le nettoyage ou l'entretien.
- Ne permettez pas qu'il soit utilisé comme jouet. Une attention particulière est nécessaire lorsque utilisé par ou près d'un enfant.
- Suivez les recommandations d'utilisation de ce manuel. Utilisez uniquement les accessoires recommandés par le fabricant.
- Le tuyau contient des fils électriques et ne doit pas être utilisé s'il est abîmé, coupé ou percé. Éviter de ramasser les objets aigus.
- Eteindre toujours l'appareil avant de connecter ou de déconnecter le tuyau ou la lance motorisée.
- Ne pas utiliser si le cordon ou la fiche sont endommagés. Si l'aspirateur ne fonctionne pas comme il le devrait, s'il a été échappé, s'il est endommagé, s'il a été laissé à l'extérieur ou échappé dans l'eau, retournez-le à un centre de service avant d'utiliser.
- Ne pas le tirer ou le transporter par le cordon, ne pas utiliser le cordon un guise de poignée. Ne pas fermer une porte sur le cordon ou tirer le cordon sur des coins ou bordures pointus. Ne pas circuler sur le cordon avec l'aspirateur. Tenir le cordon à distance des surfaces chauffantes.
- Ne pas utiliser des rallonges ou des prises qui n'ont pas de capacité suffisante pour transporter le courant.
- Fermer tous les contrôles avant de débrancher.
- Ne pas débrancher en tirant sur le cordon. Pour débrancher, tenez la fiche et non le cordon.
- Ne pas manipuler la fiche ou l'aspirateur avec les mains mouillées.
- Tenir la fiche lorsque vous rebobinez le cordon électrique. Ne pas permettre que la fiche batte l'air.
- Ne pas rien insérer dans les ouvertures. Ne pas utiliser si des ouvertures sont bloquées; assurez-vous qu'elles soient dégagées de poussière, mousse, cheveux ou toute autre chose qui pourrait réduire le passage de l'air.
- Cet aspirateur crée de la succion et contient un rouleau-brosse tournant. Tenir les parties mobiles et les ouvertures loin des cheveux, du linge, des doigts et de toute partie du corps.
- Ne pas ramasser des objets qui brûlent ou fument comme les cigarettes, allumettes ou cendres chaudes.
- N'utilisez pas sans le sac de poussière en place.
- Les poulies du courroie peuvent devenir chaudes pendant l'utilisation normale. Pour prévenir des brûlures, évitez de touché la poulie du courroie lorsque vous réparez la courroie.
- Portez une attention particulière lorsque vous nettoyez les escaliers.
- Ne pas utiliser pour ramasser des liquides inflammables ou combustibles comme de l'essence. Ne pas utiliser dans les endroits où ces liquides pourraient être présents.
- Entrez votre aspirateur à l'intérieur dans un endroit propre et sec.
- Maintenez un bon éclairage à l'endroit où vous travaillez.
- Débrancher les appareils électrique avant de les balayer.

CONSERVEZ CES INSTRUCTIONS

To reduce the risk of electric shock, this appliance has a polarized plug (one blade is wider than the other). The plug will fit in a polarized outlet only one way. If the plug does not fit fully in the outlet, reverse the plug. If it still does not fit, contact a qualified electrician to install the proper outlet. Do not change the plug in any way.

Afin de réduire le risque de choc électrique, cet appareil est muni d'une fiche polarisée (une des lames est plus large). Cette fiche ne peut être insérée dans une prise polarisée que d'une seule façon. Si la fiche ne peut être insérée dans la prise, retourner la fiche. Si la fiche ne peut toujours pas être insérée dans la prise, faire installer une prise adéquate par un électricien qualifié. Ne pas modifier la fiche.

GENERAL INFORMATION

The bag may have become dislodged in shipping. Check the bag to insure proper seating before attempting to use the cleaner. Do not operate the cleaner without a dust bag. Damage may result to the motor (see Dust Bag).

The cleaner is designed to pick up dirt and dust particles. Avoid picking up hard or sharp objects with the cleaner to avoid bag breakage, hose clogging, or possible motor damage.

Service Information

The instructions in this booklet serve as a guide to routine maintenance. For additional service information telephone our toll free number for the nearest Eureka Authorized Warranty Station. **You should know the model, type and serial numbers when you call:**

USA: 1-800-282-2886
Mexico: 254 23 52
Canada: 1-800-282-2886

If you prefer, you can write to The Eureka Company, Service Division, 807 North Main Street, Bloomington, Illinois 61701, USA. In Canada write to The Eureka Company, 866 Langs Drive, Cambridge, Ontario N3H 2N7. Refer to The Eureka Warranty for complete service information.



DO NOT OIL the motors (in the canister and the motorized nozzle) or the brush roll at any time. The bearings are permanently lubricated and sealed.

Rating Plate

The model, type and serial numbers are indicated on the rating plate located on the underneath side of the cleaner. For prompt and complete service information, always refer to these numbers when inquiring about service.

MODEL	TYPE	SERIAL NO.
VOLTS	AMPS.	HERTZ
HOUSEHOLD TYPE	SERVICE INFORMATION: 1-800-282-2886	
THE EUREKA COMPANY BLOOMINGTON, ILLINOIS 61701		

Model No. & Type _____

Serial No. _____

Automatic Motor Shut-Off

To protect from overheating, this vacuum cleaner is equipped with a thermostat which automatically shuts off the motor if it overheats. Should this happen:

1. **Turn off the switch and unplug the cleaner** because the thermostat will allow the cleaner to automatically start running again when the motor cools (approximately 30 minutes);
 2. **Check the hose, bag, and filters** as a clogged hose, full bag, or dirty filters could cause the motor to overheat; and
 3. **Call a Eureka Service Station** if the cleaner will not operate after cooling for approximately 30 minutes.
- 4

HOW TO ASSEMBLE AND USE

Canister Models 6750-6799 Series

1. Place tools in storage area.
2. Depress buttons on side of hose coupling; insert swivel hose until it locks in place. **To remove hose, depress buttons on the side of hose coupling and pull up.**
3. Twist lower cord hook up to free cord. Plug into outlet. To rewind cord, twist quick release hook down. Fasten plug to cord to prevent unwinding.
4. Place wands together with a twist; attach to end of hose.
5. Select appropriate cleaning tool, see tools illustrated on the following pages.
6. Push On/Off power switch.

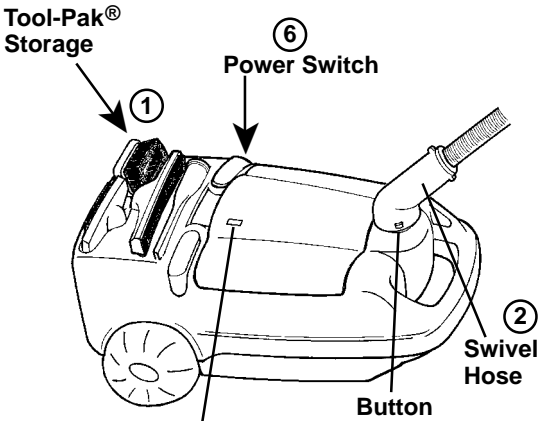

Bag Change Indicator
Change bag when warning appears.

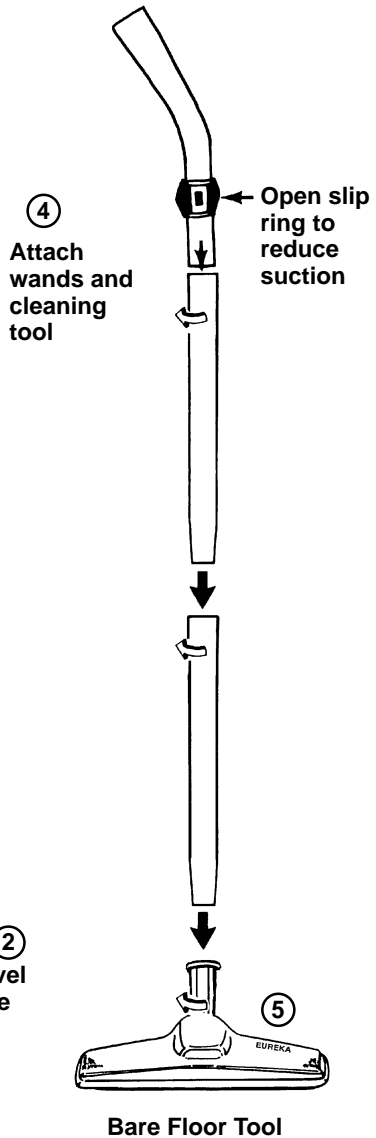
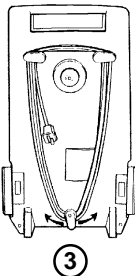

HOW TO ASSEMBLE AND USE

Home Cleaning System Models 6877-6899 Series

Power-Touch® Handle

Remote ON/OFF Selector
for bare floor or carpet

Carpet - push down on front

***Off** - middle

Bare Floor - push down on back

*Power ON/OFF can be controlled on some models from the Power-Touch handle switch or canister ON/OFF switch. Other models can only use the canister switch.

Remote Speed Control (on some models)

Regardless of the speed of the canister motor, slide to reduce or increase power as needed.

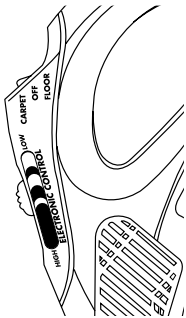

Vacuum Control (on some models)

Cleaning suction is reduced by pushing lever to LOW position. Place lever at High position to increase suction for carpet cleaning. **Available on models without Remote Speed Control.**

1. Snap interlocking wands together.
2. Push assembled wands into motorized nozzle handle socket.
3. Place electric cord between cord guide; turn to position (see Detail A).
4. Press cord into channel. **If the motorized nozzle cord plugs into the end of the hose, refer to steps 7, 8 & 9 (see Detail B). Continue below for the remote control handle.**
5. Push motorized nozzle plug into retainer; secure cord in slot (see Detail C).
6. Place Power-Touch hose handle into wands until plug connects and button locks.

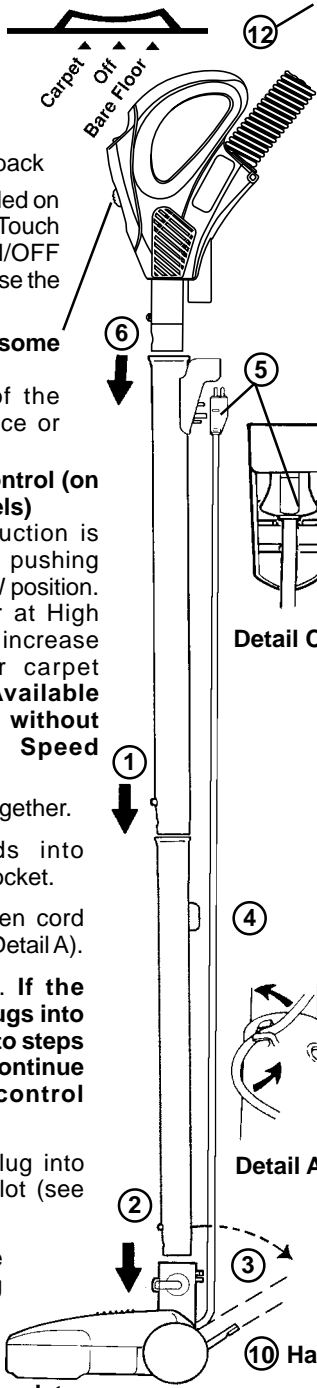

For Models 6820 - 6876 steps 1-4 and 7-9.

Detail B

9. Plug motorized nozzle cord into hose handle.

8. Insert handle end of hose into assembled wands.

7. Press cord into channels.

Open slip ring to reduce suction.

8

9

7

Detail C

Detail A

Continue on next page to complete assembly for both types of hose.

Continued

- 7. Depress buttons on side of hose coupling; insert swivel hose until it locks in place.
- 8. Plug short adapter cord into handle. Push down on the plug until the clip snaps over the ridge on the inside of the handle.
To remove hose, release the clip on the side of the handle and unplug the cord. Depress the buttons on the side of the hose coupling and pull up.

- 9. Step on Cordaway® cord reel button, pull cord, and place plug into outlet.

NOTE: Some cleaners feature a quick release cord wrap on the underneath side rather than the cord reel (see Detail D). Twist lower cord hook upward to release cord.

- 10. Step on motorized nozzle handle release; pull back to comfortable work position.
- 11. Push On/Off canister switch.
(A thermostat automatically shuts off the motor if it overheats, see Automatic Motor Shut-Off).
- 12. Select bare floor or carpet cleaning on remote control, only.

NOTE: Optional remote controls on the hose handle will only operate if the canister power switch is on.

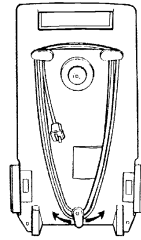

Detail D

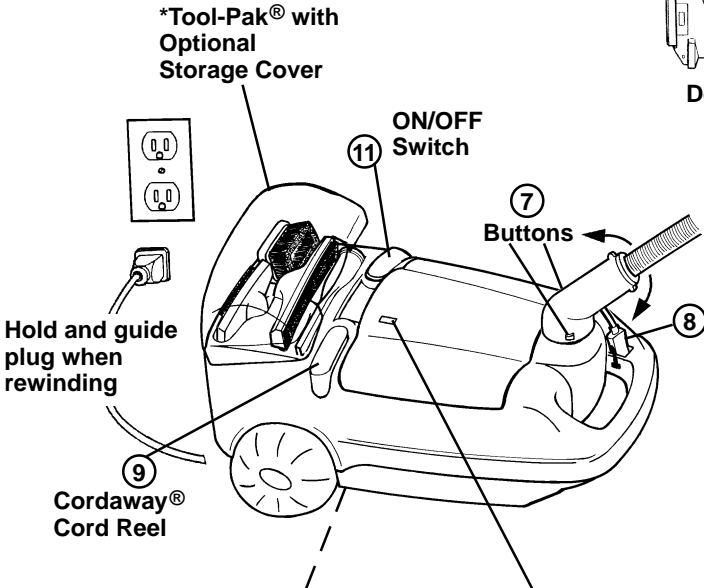

Refer to rating plate (on underside of cleaner) when inquiring about service.

Bag Change Indicator
Change bag when warning appears. Fine substances block air passage and cause indicator to move across window when bag does not appear to be full. Bag should be changed for maximum performance.

Quick Release™ Wand

System Instructions*

* On Some Models

1. Snap interlocking wands together.
2. Slide Quick Release Lower Assembly into motorized nozzle handle socket.
3. Slide interlocking wands into Quick Release Lower Assembly.
4. Run electric cord along the rear of the interlocking wands and press into cord retainer.
5. Slide top plug of the electric cord into the plug retainer of the top interlocking wand and snap cord into place. (See Detail A)
6. Place Power-Touch hose handle into wands until plug connects and button locks.

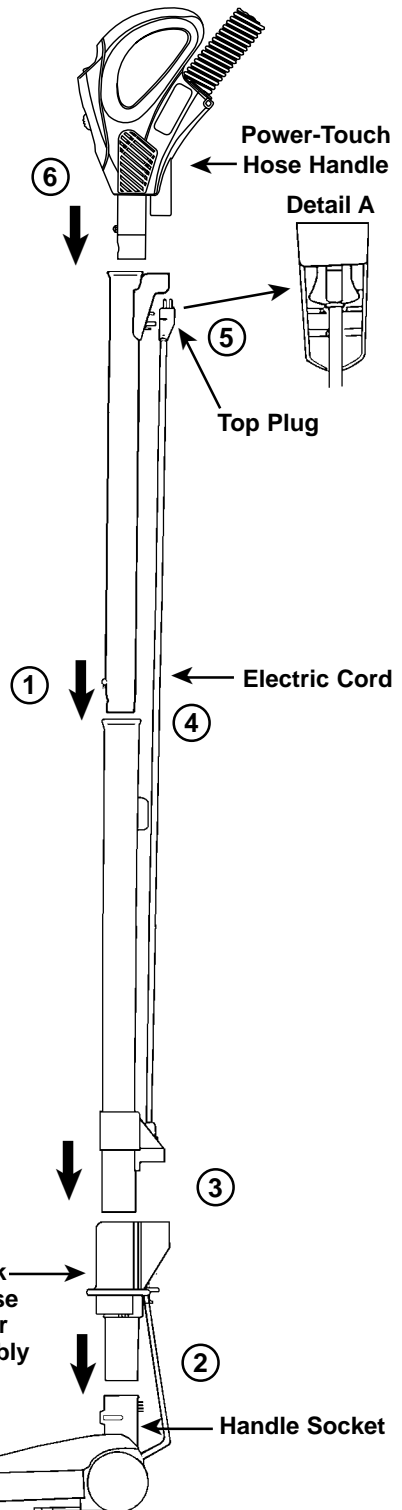

Step here
and
pull up
to release

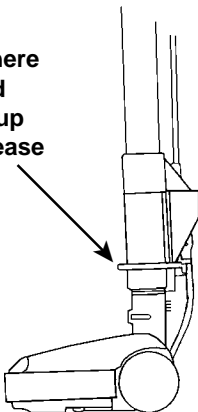

**Cyclonic Bag Saver available with some models.
To assemble the cleaner with this option
follow these instructions.**

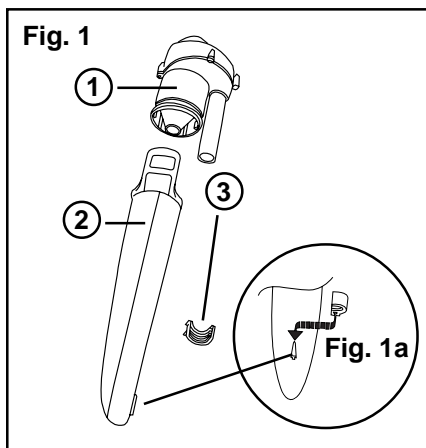

This accessory reduces the need for frequent bag changes. It does not eliminate the use of a paper bag. To remove the Cyclonic Bag Saver, follow the steps in reverse and reattach the large upper wand.

UNPACKING AND ASSEMBLING

Unpack and check that all the parts are included. The Cyclonic Bag Saver consists of three main parts, see Fig. 1:

1. Cyclonic Housing
2. Cyclone Dust Cup
3. Retaining Clip

Attach retaining clip onto the rear of the cyclonic cup as shown in Fig. 1a.

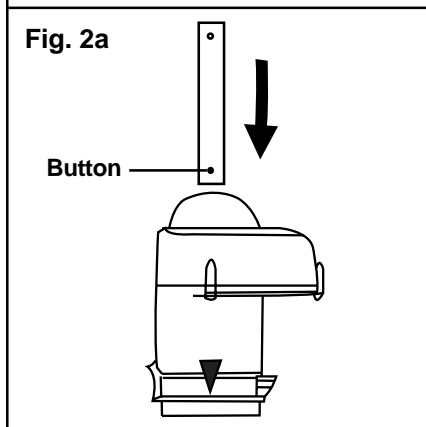

Attaching the Cyclonic Bag Saver onto the vacuum cleaner

NOTE: If the two long wands have already been assembled to the powerhead, remove the long upper wand to assemble the Cyclonic Bag Saver.

Your vacuum cleaner is equipped with three wands. Locate the short wand.

Fig. 2a Line up the small hole at the top of the short wand with the arrow on the front of the cyclonic housing. Push the short wand into the top of the cyclonic housing until button clicks into place. (You may need to rotate the wand slightly.)

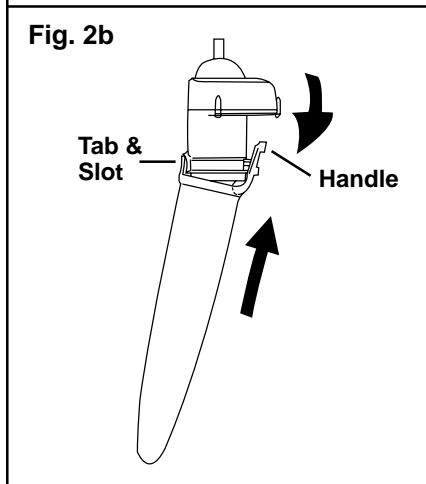
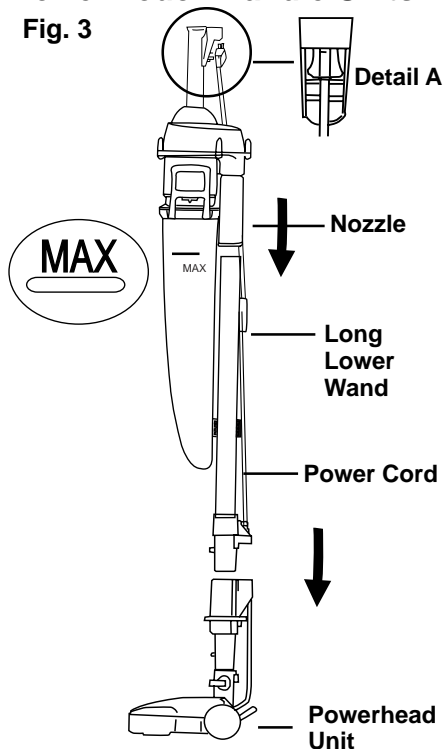

Fig. 2b Attach the cyclonic dust cup onto the cyclonic housing. Place the slot in the cyclonic dust cup over the tab on the cyclonic housing. Then grasp the handle on the cyclonic dust cup, and pivot the cyclonic dust cup up and over the ledge on the cyclonic housing.

Power-Touch Handle Units

Fig. 3



Continued

Fig. 3 Push the nozzle at the bottom of the cyclone unit into the top of the long lower wand. Adjust the position of the cyclone unit. Push the long lower wand into the powerhead unit. Plug the power cord into the power cord retainer at the top of the cyclonic housing, see Detail A. Attach the Power-Touch handle following instructions in the owner's guide.

Important Safety Information

- Do not vacuum surfaces which have been subjected to inflammable solvents.
- Do not pick up any liquid.
- Do not pick up hot ashes which could cause a fire.

Emptying

Empty the dust compartment of the cassette after each use or when the dust cup is filled up to the MAX level, Fig. 3. Detach the dust cup by following the instructions in Fig. 2b in reverse.

Empty the contents into a waste container. To reattach the dust cup again follow the described steps in Fig. 2b.

Standard Handle Units

Fig. 3

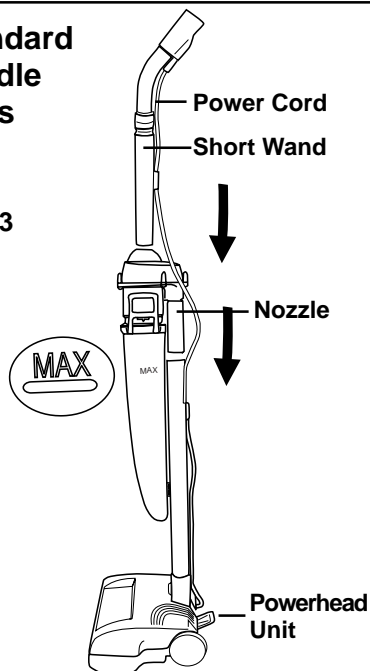

Maintenance

The Cyclonic Bag Saver can be washed in cold or warm water and a mild detergent. Thoroughly dry the dust compartment with a soft towel before using it again. If the cyclone unit clogs, use the vacuum cleaner to unclog it.

Tools

To use cleaning tools, attach directly to end of hose or use with a straight wand. Attach the circular end of tool to hose or wand with a twisting motion until it is secure.

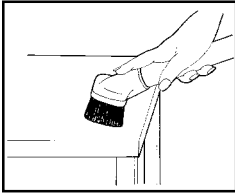

Dusting Brush

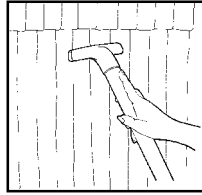

Upholstery Nozzle

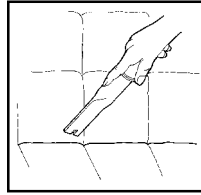

Crevice Tool

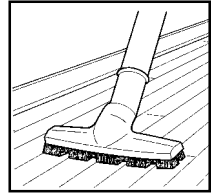

Floor Brush

Dusting brush. For furniture, blinds, books, lamp shades, shelves.

Upholstery nozzle. For curtains, draperies, cushions, fabrics.

Crevice tool. For corners, baseboards, between cushions, sliding door tracks.

Floor brush. For paneled walls, ceilings, beams, polished floors, and linoleum.

NOTE: Tools may vary with models.

HOW TO MAINTAIN

The instructions given in this booklet serve as a guide to routine maintenance. To avoid unnecessary service calls, check the bag and motor filter often.

Dust Bag and Filter

The paper bag and motor filter play a very important role in the efficiency of the vacuum cleaner. The purpose of the paper bag is to trap dirt. But at the same time, the paper bag must be porous enough to allow air to pass through. If the paper bag or the motor filter become clogged, no air can pass through the cleaner and no cleaning can take place regardless of how powerful the unit is. To keep the cleaner operating at maximum efficiency, change the dust bag frequently and clean the filter as needed. Some fine particles can restrict airflow very quickly and will decrease performance even before the bag appears to be full. For that reason, when vacuuming carpet fresheners or cleaners, powder, plaster dust, or similar fine substances, the bag may need to be changed and the filter cleaned more often.

Bag Change Indicator

(featured on some models)

To remind you to change the bag, some models feature a Bag Change Indicator. The Indicator, which is located on the canister lid, moves across the window as the airflow through the bag is decreased. Certain types of fine particles like powder, plaster dust, or fine road dust can restrict airflow very quickly and will decrease performance even before the bag appears to be full.

Therefore, when the warning color appears, the cleaner's performance is lower and the dust bag should be changed to restore maximum performance. If a clean dust bag does not restore maximum performance, check for obstructions in the hose or wands.

Check the Bag Change Indicator before each use by turning the cleaner on before attaching the cleaner hose.



Bag Change Indicator

FILTERAIRE® Disposable Dust Bag

Our high filtration bag is a two-layer, disposable bag that combines our standard paper bag with a non-woven air filter inside. Use a Filteraire dust bag to create a cleaner indoor environment because the bag filters better than our standard bag. The bags are available (three in a package) from your local dealer, or you can call 1-800-282-2886 for other locations. Look for the package of GENUINE EUREKA FILTERAIRE dust bags – Style V.

How To Change Style V Dust Bag

NOTE: Turn off the switch and unplug the electrical cord before changing dust bag. Never operate the vacuum cleaner without the dust bag or filter.

1. Lift up on bag cover; remove used bag.

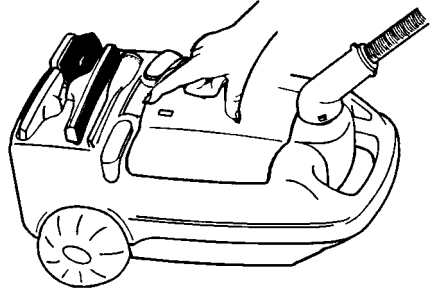

2. Clean motor filter. Remove filter and shake vigorously or rinse under warm running water. Filter must be completely dry before reinstalling to prevent motor damage. Use GENUINE EUREKA replacement motor filter 54131.

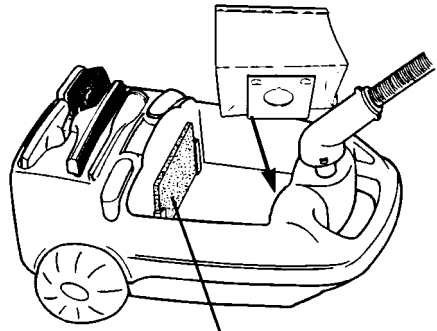

Motor Filter

3. Unfold new bag. Push bag collar into track; secure over inlet.
4. Replace bag cover.

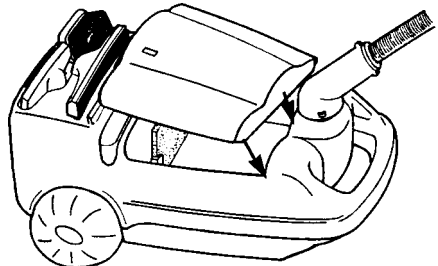

Ask for the GENUINE EUREKA dust bags – Style V

Look for the  symbol.

Brush Roll

The rotating brush roll sweeps and combs the carpet nap. Keep the brush roll free from hair and threads so it will continue brushing. When the bristles of the brush roll no longer touch a piece of cardboard held across the bottom plate, the brush roll is ineffective because the bristles no longer touch the carpet nap. To maintain the most effective cleaning, the brush roll should be replaced with a new one.

Brush Roll Belt and Light Bulb

The brush roll belt on the motorized nozzle drives the brush roll to agitate, sweep, and comb the carpet nap. The belt should be checked regularly to be sure that it is in good condition. Replace the belt if it is stretching, cracking, or slipping. Cut away any hair or thread wound around the brush roll or belt pulley because the buildup could cause the belt to rotate unevenly.

How to Replace Worn Belt or Light Bulb

Note: Turn off the switch and unplug the electrical cord before replacing belt or bulb. Pulleys can become hot during normal use. To prevent injury, avoid touching the pulleys when servicing the drive belt.

1. Remove four screws from bottom side. Turn unit over; pull up on hood to remove.

Replace light bulb, if necessary. Use GENUINE EUREKA 15 watt replacement bulb, 48815. Continue to step 2 to change belt. Skip to step 7 to replace hood.

2. Lift out brush roll and discard used belt.
3. Put new belt around brush roll pulley first; then the motor pulley.
4. Place left end cap into the base.
5. Pull right end down to seat end cap.
6. Rotate brush roll 1/2 turn to make sure belt is self-centered onto the brush roll pulley.
7. Position hood; secure with screws (see Item 1 above).

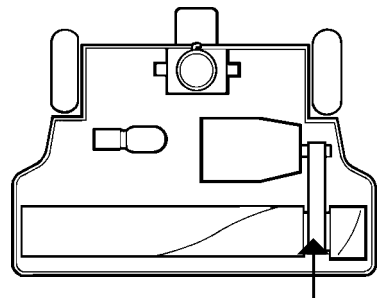
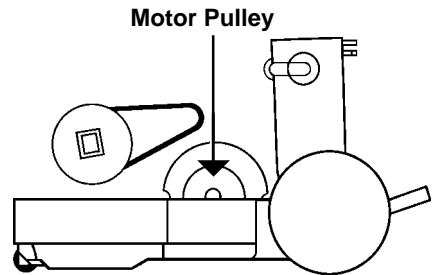
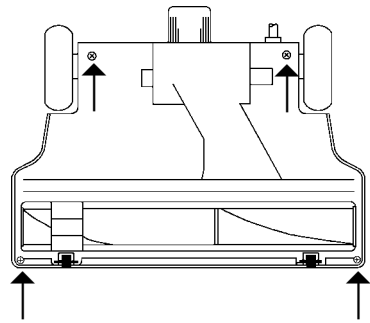

Look for the  symbol.

Use GENUINE EUREKA replacement belt, 58065.

Brush Roll Pulley

THE EUREKA LIMITED WARRANTY

What This Warranty Covers

Your Eureka cleaner is warranted to be free from all defects in material and workmanship in normal household use for a period of one year. The warranty is granted only to the original purchaser and members of his or her immediate household. The warranty is subject to the following provisions.

What This Warranty Does Not Cover

- Parts of the cleaner that require replacement under normal use, such as disposable dust bags, filters, drive belts, light bulbs, and brush roll bristles.
- Damages or malfunctions caused by negligence, abuse, or use not in accordance with the Owner's Guide.
- Defects or damages caused by unauthorized service or the use of other than Genuine Eureka parts.

What The Eureka Company Will Do

The Eureka Company will, at its option, repair or replace a defective cleaner or cleaner part that is covered by this warranty. As a matter of warranty policy, the Eureka Company will not refund the consumer's purchase price.

Warranty Registration

Please fill out and return the warranty registration card accompanying your cleaner.

Obtaining Warranty Service

To obtain warranty service you must return the defective cleaner or cleaner part along with proof of purchase to any Eureka Authorized Warranty Station. You will find the nearest location in the Yellow Pages, under "Vacuum Cleaners—Service and Repair." Be certain that the Warranty Station is "Eureka Authorized." For the location of the nearest Eureka Authorized Warranty Station or for service information, telephone toll free:

USA: 1-800-282-2886

Mexico: 254 23 52

Canada: 1-800-282-2886

If you prefer, you can write to The Eureka Company, Service Division, 807 North Main Street, Bloomington, Illinois 61701, USA. In Canada write to The Eureka Company, 866 Langs Drive, Cambridge, Ontario N3H 2N7.

If it is necessary to ship the cleaner outside your community to obtain warranty repair, you must pay the shipping charges to the Eureka Authorized Warranty Station. Return shipping charges will be paid by the Warranty Station. When returning parts for repair, please include the model, type, and serial numbers from the data plate on the cleaner.

Further Limitations and Exclusions

Any warranty that may be implied in connection with your purchase or use of the cleaner, including any warranty of Merchantability or any warranty for Fitness For A Particular Purpose is limited to the duration of this warranty. Some states do not allow limitations on how long an implied warranty lasts, so the above limitations may not apply to you.

Your relief for the breach of this warranty is limited to the relief expressly provided above. In no event shall Eureka be liable for any consequential or incidental damages you may incur in connection with your purchase or use of the cleaner. Some states do not allow the exclusion or limitation of incidental or consequential damages, so the above limitation or exclusion may not apply to you.

This warranty gives you specific legal rights. You may also have other rights which vary by state.



Questions & Answers about Genuine Eureka Products

- Q: Why should I use only Genuine Eureka paper bags, belts, and parts in my Eureka vacuum cleaner?
A: Using Genuine Eureka Products, which are made to our exacting specifications and engineered with emphasis on quality, performance, and customer satisfaction, ensures the long life and cleaning efficiency of your vacuum cleaner. Overall, this saves you money and helps to keep your home clean.
- Q: How can I be sure I am using only Genuine Eureka products in my vacuum cleaner?
A: Typically, packaged products and paper bags can be identified by a "Genuine Eureka Product" symbol (see illustration above). For further identification assistance, you may call our toll-free number, 1-800-282-2886, for the location of a nearby Eureka Authorized Warranty Station.
- Q: Are there any differences between "made to fit" or "imitation" and Genuine Eureka paper bags, belts, and parts?
A: Yes, there are some very important differences in materials, quality, and reliability. Many customers have mistakenly purchased "imitation" paper bags and parts while thinking they purchased genuine. Unfortunately, many of these customers discovered the differences after they experienced related difficulties.

**For Genuine Eureka Value, Accept No Limitations!
THE EUREKA COMPANY**

Bloomington, Illinois 61701

