

EUREKA

Upright Vacuum Cleaner

Household Type

Owner's Guide 7600-7800 Series

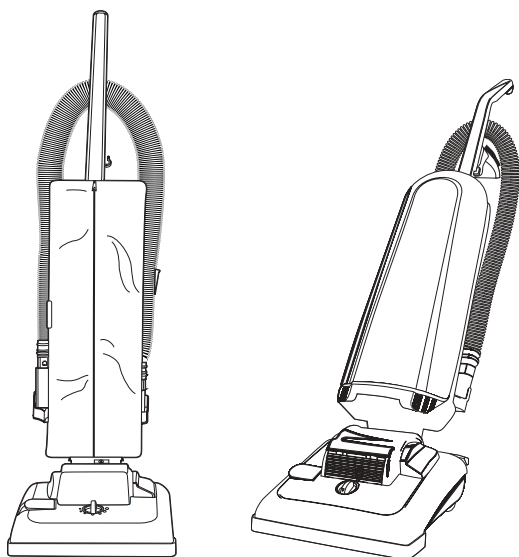

IMPORTANT

Do not return this product to the store.

For assembly problems or questions contact: Eureka's Customer Service Division toll free at 1-800-282-2886*, 7 a.m. to 8 p.m., Central Standard Time, Monday through Saturday.

For replacement of broken or missing items to be shipped directly to you, call 1-800-438-7352*, 8 a.m. to 4:45 p.m., Central Standard Time, Monday through Friday.

*En Mexico llame al 5670-6169

3 - 5	IMPORTANT INFORMATION
6 - 8	HOW TO USE
	ROUTINE MAINTENANCE
9 - 10	Dust Bag
	PERIODIC MAINTENANCE
10	Light Bulb
11	Brush Roll Brush Roll Belt
	PROBLEM SOLVING
12	Guide
13	CUSTOMER ORDER FORM
15	WARRANTY

IMPORTANT SAFEGUARDS

When using an electrical appliance, basic precautions should always be followed, including the following:

READ ALL INSTRUCTIONS BEFORE USING THIS VACUUM CLEANER.

WARNING

To reduce the risk of fire, electric shock, or injury:

- Do not use outdoors or on wet surfaces.
- **Do not leave vacuum cleaner when plugged in.** Turn off the switch and unplug the electrical cord when not in use and before servicing.
- Do not allow to be used as a toy. Close attention is necessary when used by or near children.
- Use only as described in this manual. Use only manufacturer's recommended attachments.
- Do not use with damaged cord or plug. If vacuum cleaner is not working as it should, has been dropped, damaged, left outdoors, or dropped into water, return it to a service center before using.
- Do not pull or carry by cord, use cord as a handle, close a door on cord, or pull cord around sharp edges or corners. Do not run vacuum cleaner over cord. Keep cord away from heated surfaces.
- Do not use extension cords or outlets with inadequate current carrying capacity.
- Turn off all controls before unplugging.
- Do not unplug by pulling on cord. To unplug, grasp the plug, not the cord.
- Do not handle plug or vacuum cleaner with wet hands.
- Do not put any object into openings. Do not use with any opening blocked; keep free of dust, lint, hair, and anything that may reduce airflow.
- This vacuum cleaner creates suction and contains a revolving brush roll. Keep hair, loose clothing, fingers, and all parts of body away from openings and moving parts.
- Do not place cleaner on furniture or stairs as the brush roll may cause damage. Place cleaner on floor with the handle in storage position while using attachments.
- Do not pick up anything that is burning or smoking, such as cigarettes, matches, or hot ashes.
- Do not use without dust bag in place.
- Belt pulleys can become hot during normal use. To prevent burns, avoid touching the belt pulley when servicing the drive belt.
- Use extra care when cleaning on stairs.
- Do not use to pick up flammable or combustible liquids such as gasoline, or use in areas where they may be present.
- Unplug your cleaner and store indoors in a cool, dry area.
- Keep your work area well lighted.
- Unplug electrical appliances before vacuuming them.

SAVE THESE INSTRUCTIONS

To reduce the risk of electric shock, this appliance has a polarized plug (one blade wider than the other). This plug will fit in a polarized outlet only one way. If the plug does not fit fully in the outlet, reverse the plug. If it still does not fit, contact a qualified electrician to install the proper outlet. Do not change the plug in any way.

Afin de réduire le risque de choc électrique, cet appareil est muni d'une fiche polarisée (une des lames est plus large). Cette fiche ne peut être insérée dans une prise polarisée que d'une seule façon. Si la fiche ne peut être insérée dans la prise, retourner la fiche. Si la fiche ne peut toujours pas être insérée dans la prise, faire installer une prise adéquate par un électricien qualifié. Ne pas modifier la fiche.

GENERAL INFORMATION

The cleaner is designed to pick up dirt and dust particles. Avoid picking up hard or sharp objects with the cleaner to prevent bag tears, hose clogs, and fan blade breakage with subsequent motor damage.

Service Information

The instructions in this booklet serve as a guide to routine maintenance. For additional service information telephone our toll free number for the nearest Eureka Authorized Warranty Station. **You should know the model, type and serial numbers when you call:**

USA: 1-800-282-2886
Mexico: 5670-6169
Canada: 1-800-282-2886

If you prefer, you can write to The Eureka Company, Service Division, 807 North Main Street, Bloomington, Illinois 61701, USA. In Canada write to The Eureka Company, 866 Langs Drive, Cambridge, Ontario N3H 2N7. Refer to The Eureka Limited Warranty for complete service information.



DO NOT OIL the motor or the brush roll at any time. The bearings are permanently lubricated and sealed.

Rating Plate

The model, type, and serial numbers are indicated on the rating plate located on the back of the cleaner. For prompt and complete service information, always refer to these numbers when inquiring about service.

Model & Type _____

Serial No. _____

MODEL	TYPE	SERIAL NO.
VOLTS	AMPS.	HERTZ
SERVICE INFORMATION: 1-800-282-2886		
THE EUREKA COMPANY		
BLOOMINGTON, ILLINOIS 61701		

Thermal Cut Off

This vacuum cleaner has a special thermostat that protects the cleaner from further damage in case of serious motor overheating. If the cleaner suddenly shuts off, unplug the unit, discontinue use, and take it to a Eureka Authorized Service Center for repair.

NOTE: The thermostat will reset after the motor cools off.

HOW TO USE

CAUTION: Never leave plugged in cleaner unattended.

An upright vacuum cleaner will clean any type of carpet. Use the attachments to clean upholstery or bare floors. **When using attachment tools, place the handle in the upright position. Do not place cleaner on furniture or steps as the brush roll may cause damage.**

HOW TO USE

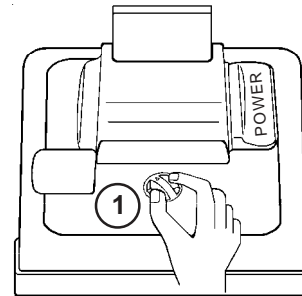
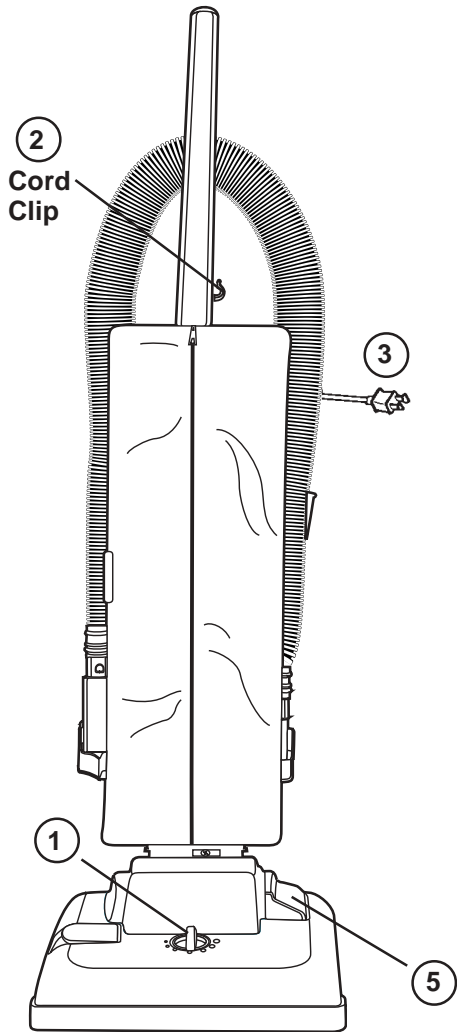

1. Adjust cleaner height setting to lowest position for maximum cleaning. Adjust to a higher setting to make pushing easier. For easy adjustment, tilt the cleaner back to move setting knob.
2. Place electrical cord out of the way on the cord clip while vacuuming or storing.
3. Plug electrical cord into outlet.

Cleaner Height Setting

WARNING: Avoid injury. Keep loose clothing, hair, fingers, and all other parts of body away from any moving part (such as the revolving brush). Turn off the switch and unplug the cleaner before changing the cleaner height setting.

The front of the cleaner has an adjustment that raises or lowers the cleaner base to match the type of carpet. With the cleaner cord unplugged, set the adjustment to lowest setting for maximum cleaning. If the cleaner is difficult to push, move adjustment to next highest setting until cleaner is comfortable to push. The brush roll must reach the carpet for effective cleaning.

Make each adjustment with cleaner switch off and cord disconnected from outlet. For ease in moving the adjustment knob, place handle in operating position and tilt cleaner back to remove weight from front wheels.

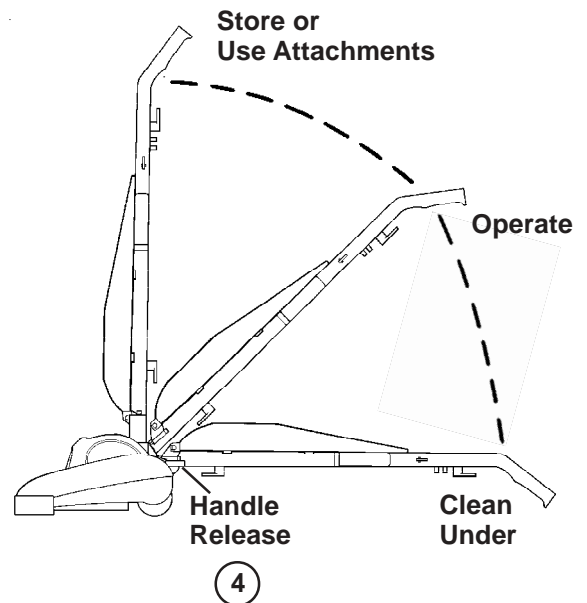

4. Step on handle release. Pull handle back to a comfortable position.
5. Push On or Off power switch.

Attachment Cleaning

Note: The revolving brush roll does not stop turning when using the attachment tools. Place the handle in the upright position. Do not place cleaner on furniture or steps as the brush roll may cause damage.

Attachment Door

The attachment door allows a quick conversion from floor to attachment tool cleaning. The quick connect hose has a notch in the converter that diverts the air suction from the brush roll area to the hose and attachments.

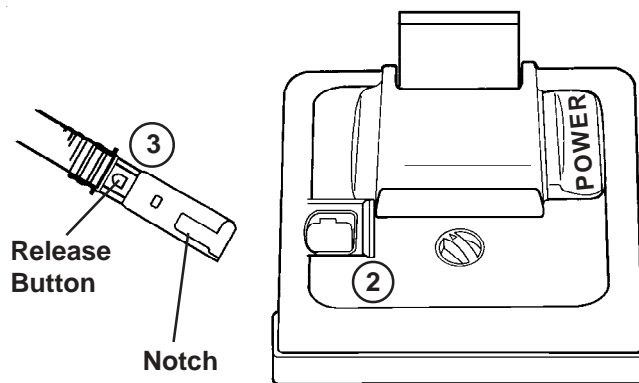
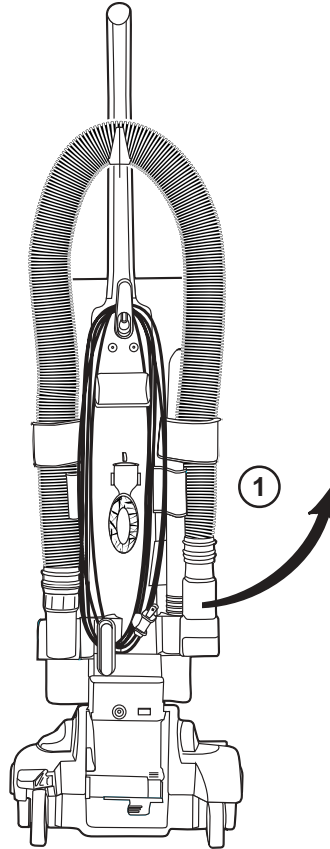

1. Remove quick connect hose.
2. Open and hold the attachment door.
3. Push hose converter into attachment door (be sure notch in the converter is toward back of cleaner).

To remove converter, push button on back of converter and lift to remove. Place into back of cleaner.

How To Use Attachments

NOTE: Do not place cleaner on furniture or steps as the brush roll may cause damage. Place cleaner on floor with the handle in storage position while using attachments.

Put attachment onto wand. Twist to secure.

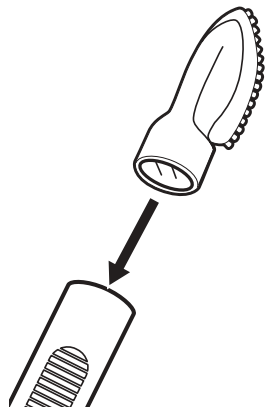

Dusting/Upholster Brush cleans furniture, blinds, books, lamp shades, curtains, draperies, cushions and fabrics.

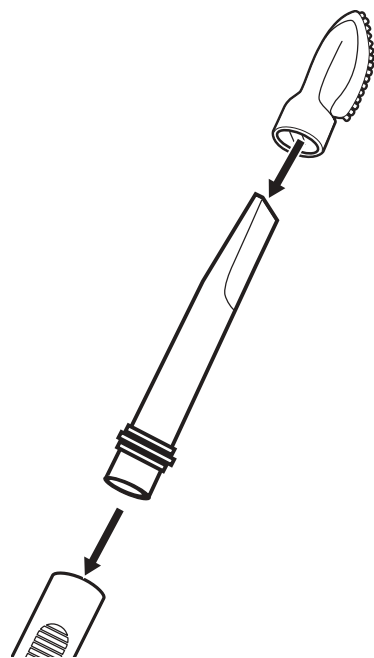

Crevice wand cleans corners, baseboards, between cushions.

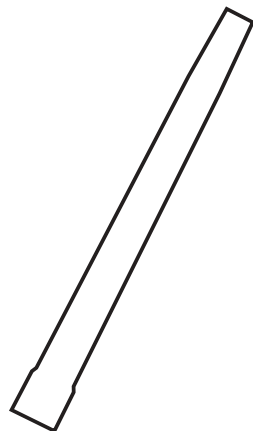

Extension wand for added reach. (On some models only.)

HOWTO USE

Disposable Dust Bags

The disposable dust bag plays a very important role in the efficiency of a vacuum cleaner. The purpose of the paper bag is to trap dirt. As the bag traps dirt, it must also be porous enough to allow air to pass on through. If the paper bag becomes clogged, no air can pass through the cleaner and no cleaning can take place regardless of how powerful the unit. Change the dust bag frequently. Some fine particles can restrict airflow very quickly and will decrease performance even before the bag appears to be full.

When vacuuming carpet fresheners or cleaners, powder, plaster dust, or similar fine substances, the bag may require more frequent maintenance.

Be sure to use GENUINE EUREKA bags for best performance. If a clean dust bag does not restore maximum performance, check for obstructions in the hose or airflow passage.

How To Change Dust Bag–Style U

NOTE: Turn off the switch and unplug the electrical cord before changing dust bag. Never operate the vacuum cleaner without the dust bag.

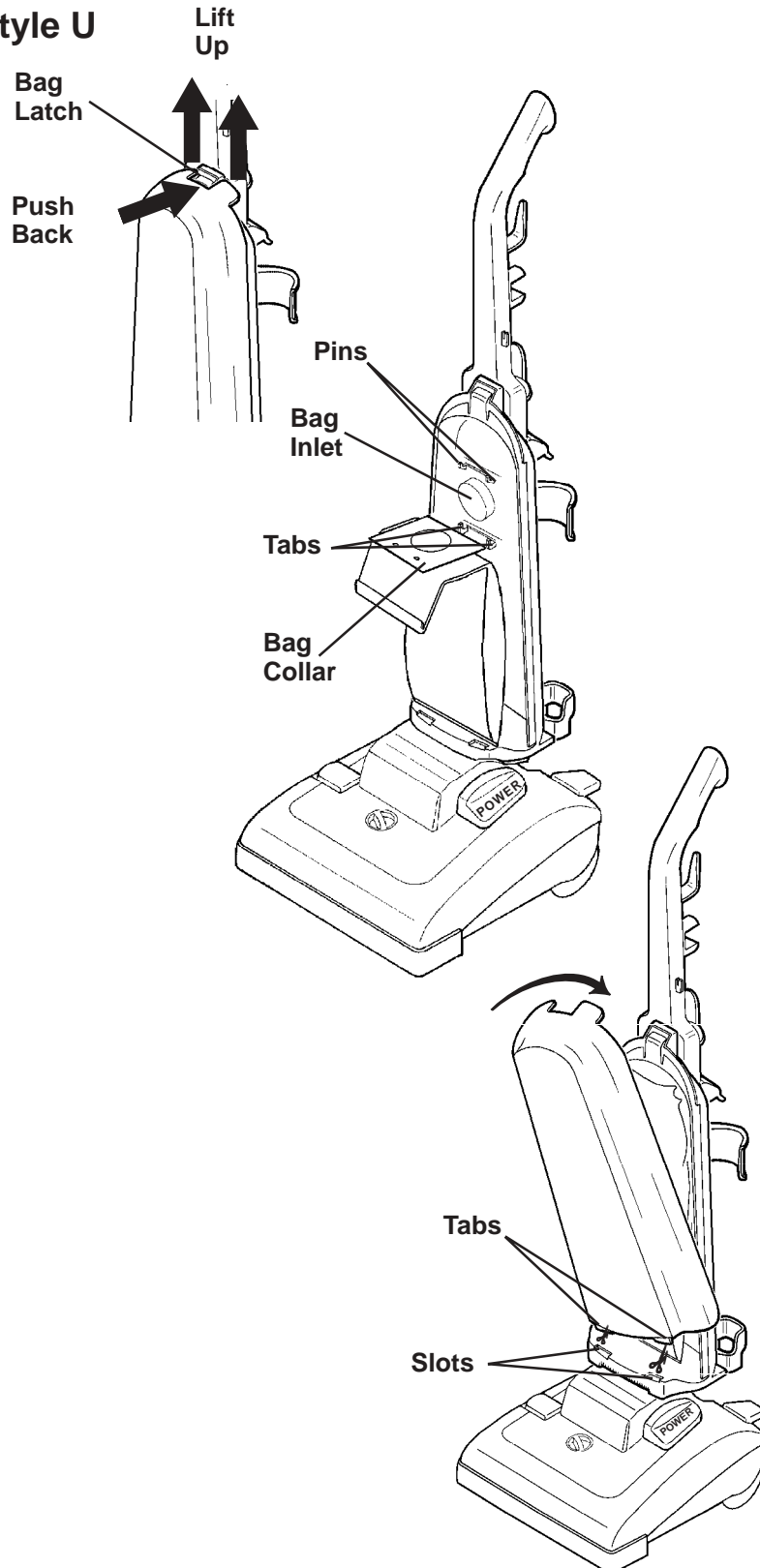

Hard Case Model

1. Remove the bag cover.
2. Fold top of paper bag down. Grasp bag collar to remove dirty bag from bag inlet. Discard bag.
3. Hold new dust bag collar facing the bag inlet.
4. Secure lower bag collar behind the tabs.
5. Push bag collar over bag inlet.
6. Snap over the two pins at the top.
7. Tuck top and bottom of paper bag into the area.
8. Replace bag cover.

Soft Bag Model

1. Unzip the bag.
2. Fold top of paper bag down. Grasp bag collar to remove dirty bag from bag inlet. Discard bag.
3. Hold new dust bag collar facing the bag inlet.
4. Secure lower bag collar behind the tabs.
5. Push bag collar over bag inlet.
6. Snap over the two pins at the top.
7. Tuck top and bottom of paper bag into the area.
8. Close the zipper.

Ask for **GENUINE EUREKA** dust bags—Style U.

Look for the red package and the symbol.

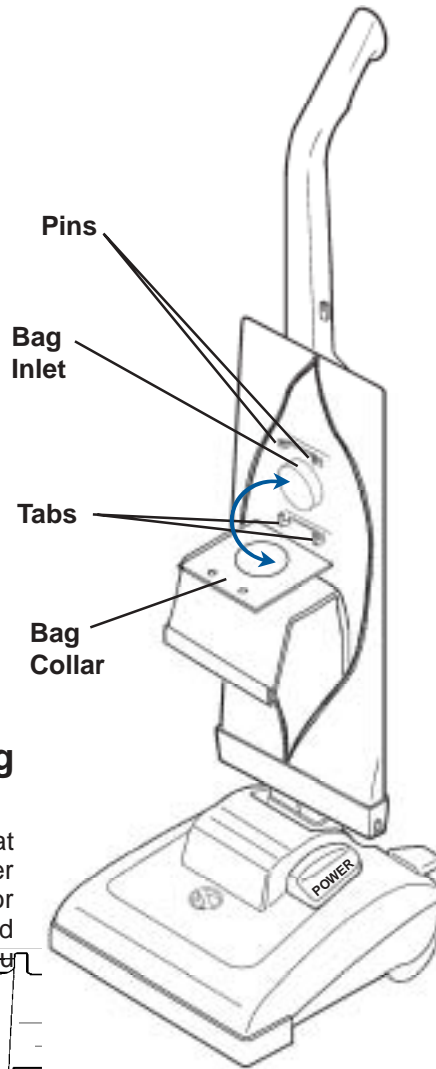

ROUTINE MAINTENANCE

Dust Bag

FILTERAIRE® Disposable Dust Bag (optional)

Our high filtration bag is a two-layer, disposable bag that combines our standard paper bag with a non-woven air filter inside. Use a Filteraire dust bag to create a cleaner indoor environment because the bag filters better than our standard bag. The bags are available from your local dealer, or you can call 1-800-282-2886 for other locations.

How To Replace Light Bulb

NOTE: Turn off the switch and unplug the electrical cord before changing light bulb.

1. Use blade screwdriver to release two tabs on top of lens. Push and twist blade screwdriver into notch. Repeat for second notch.
2. Pull out light bulb; push new bulb into place. **Use GENUINE EUREKA bulb, No. 57940-1.**
3. Place bottom of lens into hood; push top of lens to secure.

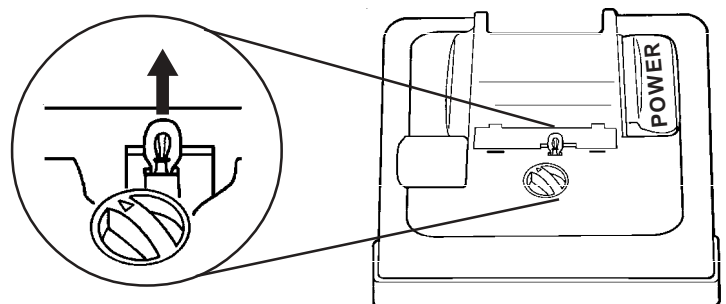
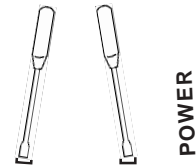

PERIODIC MAINTENANCE

Light Bulb

HOW TO MAINTAIN

The instructions in this booklet serve as a guide to routine maintenance. To avoid unnecessary service calls, check the bag, belt, and brush roll often.

Brush Roll

The brush roll turns to brush and sweep the carpet. Remove hair and threads from the brush roll so it can continue to brush the carpet. To maintain the most efficient cleaning, the bristles must touch the carpet. To test the bristle length, hold a ruler against the underneath side of the cleaner. If the bristles no longer touch the ruler, replace the brush roll.

Brush Roll Belt

The brush roll belt turns the brush roll as the bristles sweep and brush the carpet. Check the belt regularly to be sure it is in good condition. Replace the belt if it stretches, cracks or loses tension. Cut away any hair or threads wound around the brush roll or the belt pulley because the buildup could cause the belt to rotate unevenly.

How to Replace Brush Roll Belt

NOTE: Turn off the switch and unplug the electrical cord before replacing belt. Belt pulleys can become hot during normal use. To prevent injury, avoid touching the motor pulley when checking the belt.

CAUTION: Improper installation of the brush roll could cause carpet or cleaner damage.

1. Turn the cleaner over. Pull up to remove bottom plate.
2. Lift out brush roll and discard old belt.
3. Fold new belt to slide it around the motor pulley.
4. Place belt around pulley end of brush roll.
5. Pull left end of brush roll down to stretch belt. Align the end cap with the base and push down to secure.
6. Seat right end cap.
7. Turn the brush roll until the belt centers onto the brush roll pulley.
8. Slant front of bottom plate to catch tabs into cleaner slots. Push down above each hook to snap into place.

Use **GENUINE EUREKA** replacement belt, 54312.

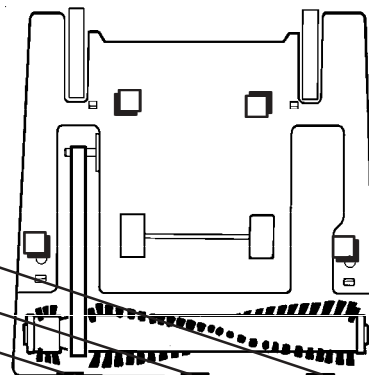
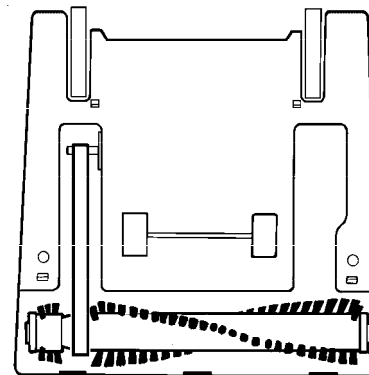
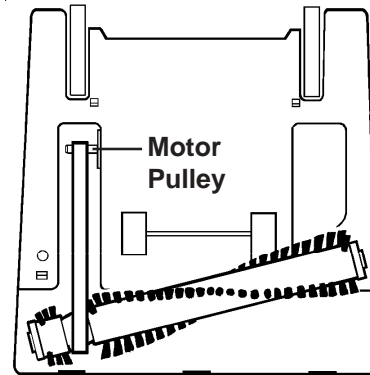
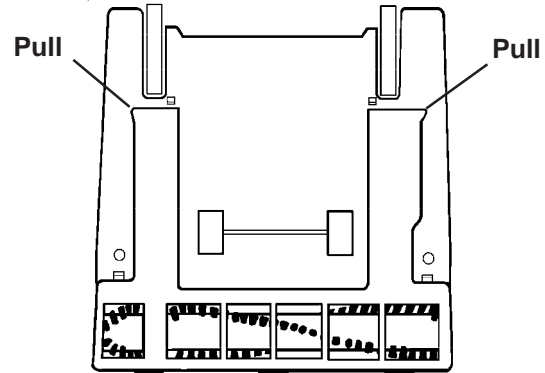

Look for the **GENUINE EUREKA PRODUCT** symbol.

For location of nearest Eureka Warranty Station or Service information call **1-800-282-2886**.

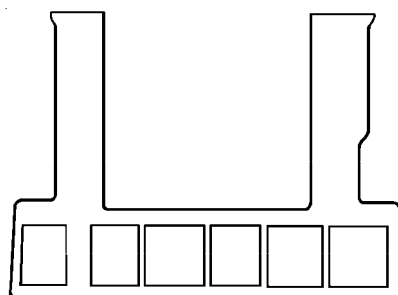

Tabs

Slots

PERIODIC MAINTENANCE

Brush Roll

Brush Roll Belt

PROBLEM SOLVING

NOTE: Turn off the switch and unplug the electrical cord before servicing.

PROBLEM	CAUSE	SOLUTION
Motor will not start.	<input checked="" type="checkbox"/> Electric Plug	<input type="checkbox"/> Push plug securely into outlet. <input type="checkbox"/> Try another outlet. <input type="checkbox"/> Check circuit breaker.
Does not clean the carpet.	<input checked="" type="checkbox"/> Disposable Dust Bag <input checked="" type="checkbox"/> Belt <input checked="" type="checkbox"/> Brush Roll <input checked="" type="checkbox"/> Hose	<input type="checkbox"/> Change the bag. Hint: If picking up fine dust, the bag may <u>not</u> look full but a fine substance tends to reduce suction when it blocks the airflow through the paper bag. <input type="checkbox"/> Replace a cut, loose or out of shape belt. <input type="checkbox"/> Clean hair and thread from bristles and end cap area. Replace brush roll if bristles are worn. <input type="checkbox"/> Remove any clogs from the hose that restrict the airflow.
No suction at the end of the hose.	<input checked="" type="checkbox"/> Hose Converter <input checked="" type="checkbox"/> Disposable Dust Bag <input checked="" type="checkbox"/> Hose <input checked="" type="checkbox"/> Attachment Door or Hose Connection on Base.	<input type="checkbox"/> Hose converter has to seat inside the attachment door. <input type="checkbox"/> Hint: Place converter notch to the back of the cleaner. Change the bag. Hint: If picking up fine dust, the bag may <u>not</u> look full, but a fine substance tends to reduce suction when it blocks the airflow through the paper bag. <input type="checkbox"/> Remove any clogs from the hose that restrict the airflow. Check both ends of the hose. <input type="checkbox"/> Remove bottom plate and clean debris from the attachment door area or around the hose connection.
Motor suddenly shuts off.	<input checked="" type="checkbox"/> Thermal Cut-Off	<input type="checkbox"/> Refer to page 5.
Headlight not working.	<input checked="" type="checkbox"/> Light Bulb	<input type="checkbox"/> Replace light bulb.
Noise from the brush roll area.	<input checked="" type="checkbox"/> Brush Roll <input checked="" type="checkbox"/> Belt	<input type="checkbox"/> Remove bottom plate and clean debris from the brush roll area. <input type="checkbox"/> Replace a cut, loose or out of shape belt.
Cleaner is hard to push.	<input checked="" type="checkbox"/> Cleaner Height Setting <input checked="" type="checkbox"/> Belt	<input type="checkbox"/> Turn adjustment knob to a higher position. Hint: Put handle in operating position. Tilt the cleaner back to raise the front wheels off floor Then turn the knob. <input type="checkbox"/> Replace cut, loose or out of shape belt.
Brush roll will not turn.	<input checked="" type="checkbox"/> Belt	<input type="checkbox"/> Replace cut, loose or out of shape belt.
Burning smell.	<input checked="" type="checkbox"/> Belt	<input type="checkbox"/> Replace cut, loose or out of shape belt.
Cleaning height knob will not turn.	<input checked="" type="checkbox"/> Cleaner Height Setting	<input type="checkbox"/> Hint: Put handle in operating position. Tilt the cleaner back to raise the front wheels off floor. Then turn the knob.
Missing parts		<input type="checkbox"/> Call 1-800-438-7352 between 8:00 am and 4:45 pm central standard time, Monday through Friday. Know the model and serial numbers when you call.
Questions?		<input type="checkbox"/> Call 1-800-282-2886, 7 am to 8 pm, central standard time, Monday through Saturday. Know the model and serial numbers when you call.

THE EUREKA LIMITED WARRANTY

What This Warranty Covers

Your Eureka cleaner is warranted to be free from all defects in material and workmanship in normal household use for a period of one year. The warranty is granted only original purchaser and members of his or her immediate household. The warranty is subject to the following provisions.

What This Warranty Does Not Cover

- Parts of the cleaner that require replacement under normal use, such as disposable dust bags, filters, drive belts, light bulbs, and brush roll bristles
- Damages or malfunctions caused by negligence, abuse, or use not in accordance with the Owner's Guide.
- Defects or damages caused by unauthorized service or the use of other than Genuine Eureka parts.

What The Eureka Company Will Do

The Eureka Company will, at its option, repair or replace a defective cleaner or cleaner part that is covered by this warranty. As a matter of warranty policy, the Eureka Company will not refund the consumer's purchase price.

Warranty Registration

Please fill out and return the warranty registration card accompanying your cleaner.

Obtaining Warranty Service

To obtain warranty service you must return the defective cleaner or cleaner part along with proof of purchase to any Eureka Authorized Warranty Station. You will find the nearest location in the Yellow Pages, under "Vacuum Cleaners—Service and Repair." Be certain that the Warranty Station is "Eureka Authorized." For the location of the nearest Eureka Authorized Warranty Station or for service information, telephone toll free:

USA: 1-800-282-2886

Mexico: 5670-6169

Canada: 1-800-282-2886

If you prefer, you can write to The Eureka Company, Service Division, 807 North Main Street, Bloomington, Illinois 61701, USA. In Canada write to The Eureka Company, 866 Lings Drive, Cambridge, Ontario N3H 2N7.

If it is necessary to ship the cleaner outside your community to obtain warranty repair, you must pay the shipping charges to the Eureka Authorized Warranty Station. Return shipping charges will be paid by the Warranty Station. When returning parts for repair, please include the model, type, and serial number from the data plate on the cleaner.

Further Limitations and Exclusions

Any warranty that may be implied in connection with your purchase or use of the cleaner, including any warranty of Merchantability or any warranty for Fitness For A Particular Purpose is limited to the duration of this warranty. Some states do not allow limitations on how long an implied warranty lasts, so the above limitations may not apply to you.

Your relief for the breach of this warranty is limited to the relief expressly provided above. In no event shall Eureka be liable for any consequential or incidental damages you may incur in connection with your purchase or use of the cleaner. Some states do not allow the exclusion or limitation of incidental or consequential damages, so the above limitation or exclusion may not apply to you.

This warranty gives you specific legal rights. You may also have other rights which vary by state.



Questions & Answers about Genuine Eureka Products

- Q** Why should I use only Genuine Eureka paper bags, belts, and parts in my Eureka vacuum cleaner?
A Using Genuine Eureka Products, which are made to our exacting specifications and engineered with emphasis on quality, performance, and customer satisfaction, ensures the long life and cleaning efficiency of your vacuum cleaner. Overall, this saves you money and helps to keep your home clean.
- Q** How can I be sure I am using only genuine Eureka products in my vacuum cleaner?
A Typically, packaged products and paper bags can be identified by a "Genuine Eureka Product" symbol (see illustration above). For further identification assistance, you may call our toll-free number, 1-800-282-2886, for the location of a nearby Eureka Authorized Warranty Station.
- Q** Are there any differences between "made to fit" or "imitation" and Genuine Eureka paper bags, belts, and parts?
A Yes, there are some very important differences in materials, quality, and reliability. Many customers have mistakenly purchased "imitation" paper bags and parts while thinking they purchased genuine. Unfortunately, many of these customers discovered the differences after they experienced related difficulties.

For Genuine Eureka Value, Accept No Imitations!

THE EUREKA COMPANY

Household Warranty
abs 190

Bloomington, Illinois 61701

Questions? Do Not Return To Store Call 1-800-282-2886

7 a.m. to 8 p.m., Central Standard Time, Monday thru Saturday

Accessory Items in This Carton



1 crevice wand



1 dusting brush/
upholstery brush



1 extension wand
(On some models only.)

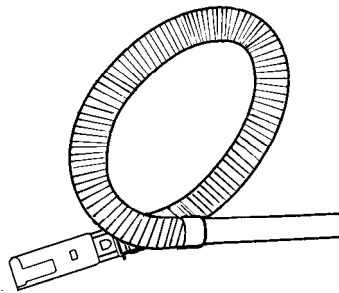

7600 Series Only

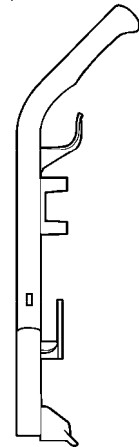

1 vacuum cleaner handle



(2 fasteners)



1 screw
1 nut

Thank you for selecting a Eureka cleaner.

Don't Forget to Use Genuine Eureka Bags and Belts

Caution: Damages caused by the use of non-genuine Eureka bags are not covered by the Eureka Limited Warranty.