

EUREKA

Mighty Mite®

Household Type

Vacuum Cleaner Owner's Guide 3690 Series

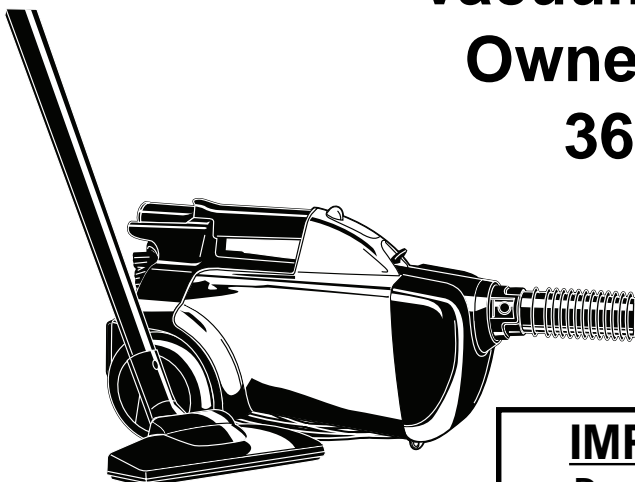

Index

Important Safeguards	2
Service Information	4
How to Use	5-6
Dust Cup	7
Filters	8-9
Problem Solving	10
Warranty	11-12
Customer Order Form	Center

IMPORTANT

Do not return this product to the store.

For assembly problems or questions contact: Eureka's Customer Service Division toll free at 1-800-282-2886*, 7 a.m. to 8 p.m., Central Standard Time, Monday through Saturday.

For replacement of broken or missing items to be shipped direct to you, call 1-800-438-7352*, 8 a.m. to 4:45 p.m., Central Standard Time, Monday through Friday.

***En Mexico llame al 5670-6169.**

IMPORTANT SAFEGUARDS

When using an electric appliance, basic precautions should always be followed, including the following:

READ ALL INSTRUCTIONS BEFORE USING THIS VACUUM CLEANER.

WARNING

To reduce the risk of fire, electric shock, or injury:

- Do not use outdoors or on wet surfaces.
- **Do not leave vacuum cleaner when plugged in.** Turn off the switch and unplug the electrical cord when not in use and before servicing.
- Do not allow to be used as a toy. Close attention is necessary when used by or near children.
- Use only as described in this manual. Use only manufacturer's recommended attachments.
- Do not use with damaged cord or plug. If vacuum cleaner is not working as it should, has been dropped, damaged, left outdoors, or dropped into water, return it to a service center before using.
- Do not pull or carry by cord, use cord as a handle, close a door on cord, or pull cord around sharp edges or corners. Do not run vacuum cleaner over cord. Keep cord away from heated surfaces.
- Do not use extension cords or outlets with inadequate current carrying capacity.
- Turn off all controls before unplugging.
- Do not unplug by pulling on cord. To unplug, grasp the plug, not the cord.
- Do not handle plug or vacuum cleaner with wet hands or operate without shoes.
- Do not put any object into openings. Do not use with any opening blocked; keep free of dust, lint, hair, and anything that may reduce airflow.
- This vacuum cleaner creates suction. Keep hair, loose clothing, fingers, and all parts of body away from openings and moving parts.
- Do not pick up anything that is burning or smoking, such as cigarettes, matches, or hot ashes.
- Do not use without dust bag or filter(s) in place.
- Use extra care when cleaning on stairs.
- Do not pick up flammable or combustible liquids such as gasoline, or use in areas where they may be present.
- Store your cleaner indoors in a cool, dry area.
- Keep your work area well lighted.
- Unplug electrical appliances before vacuuming them.

SAVE THESE INSTRUCTIONS

CONSEILS DE SÉCURITÉ

Lors de l'utilisation d'un appareil électrique, quelques précautions élémentaires doivent être observées, incluant les suivantes:

LISEZ TOUTES LES INSTRUCTIONS AVANT D'UTILISER VOTRE ASPIRATEUR.

AVERTISSEMENT

Pour réduire le risque de feu, de choc électrique ou de blessure:

- Ne pas utiliser l'aspirateur à l'extérieur ou sur une surface mouillée.
- **Ne pas laisser l'aspirateur seul quand il est branché.** Mettre l'interrupteur sur arrêt et débrancher l'appareil lorsque vous ne l'utilisez pas ou avant l'entretien.
- Ne pas permettre que l'aspirateur soit utilisé comme un jouet. Une attention particulière est nécessaire lorsqu'il est utilisé par ou près d'un enfant.
- Suivre strictement les recommandations d'utilisation de ce manuel. Utiliser uniquement les accessoires recommandés par le fabricant.
- Ne jamais utiliser l'aspirateur si le cordon ou la fiche sont endommagés. Si l'aspirateur ne fonctionne pas comme il le devrait, s'il a été échappé, s'il est endommagé, s'il a été laissé à l'extérieur ou échappé dans de l'eau, le retourner à un centre de service avant de l'utiliser.
- Ne pas l'aspirateur ou le transporter par le cordon. Ne pas utiliser le cordon en guise de poignée. Ne pas fermer une porte sur le cordon ou tirer le cordon sur des bordures ou des coins pointus. Ne pas passer l'aspirateur sur le cordon. Tenir le cordon à distance des surfaces chauffantes.
- Ne pas utiliser des cordons de rallonge ou des prises qui n'ont pas une capacité suffisante pour transporter le courant.
- Mettre sur arrêt tous les boutons de commande avant de débrancher.
- Ne pas débrancher l'aspirateur en tirant sur le cordon. Pour débrancher saisir la fiche et non pas le cordon.
- Ne pas manipuler la fiche ou l'aspirateur les mains mouillées ou faire fonctionner pieds nus.
- Ne rien insérer dans les ouvertures. Ne pas utiliser l'aspirateur si des ouvertures sont bloquées. Vous assurer qu'elles soient dégagées de poussière, de mousse, de cheveux ou de tout autre chose qui pourrait réduire le passage de l'air.
- Cet aspirateur crée de la succion. Tenir les parties mobiles et les ouvertures loin des cheveux, du linge, des doigts et de toute partie du corps.
- Ne pas ramasser des objets qui brûlent ou fument comme les cigarettes, les allumettes ou les cendres chaudes.
- Ne pas utiliser sans que le sac à poussière ou le(s) filtre(s) ne soient en place.
- Porter une attention particulière lorsque vous nettoyez les escaliers.
- Ne pas utiliser pour ramasser des liquides inflammables ou combustibles, comme de l'essence. Ne pas utiliser dans les endroits où ces liquides pourraient être présents.
- Entreposer votre aspirateur à l'intérieur, dans un endroit propre et sec.
- Maintenir un bon éclairage à l'endroit où vous travaillez.
- Débrancher les appareils électriques avant de les passer à l'aspirateur.

CONSERVEZ CES INSTRUCTIONS

To reduce the risk of electric shock, this appliance has a polarized plug (one blade is wider than the other). This plug will fit in a polarized outlet only one way. If the plug does not fit fully into the outlet, reverse the plug. If it still does not fit, contact a qualified electrician to install the proper outlet. Do not change the plug in any way.

Afin de réduire le risque de choc électrique, cet appareil est muni d'une fiche polarisée (une des lames est plus large). Cette fiche ne peut être insérée dans une prise polarisée que d'une seule façon. Si la fiche ne peut être insérée dans la prise, retourner la fiche. Si la fiche ne peut toujours pas être insérée dans la prise, faire installer une prise adéquate par un électricien qualifié. Ne pas modifier la fiche.

GENERAL INFORMATION

The cleaner is designed to pick up dirt and dust particles. Avoid picking up hard or sharp objects with the cleaner to avoid bag breakage, hose clogging, or possible motor damage.

Service Information

The instructions in this booklet serve as a guide to routine maintenance. For additional service information telephone our toll free number for the nearest Eureka Authorized Warranty Station. **You should know the model, type and serial numbers when you call:**

USA: 1-800-282-2886

Mexico: 5670-6169

Canada: 1-800-282-2886

If you prefer, you can write to The Eureka Company, Service Division, 807 North Main Street, Bloomington, Illinois 61701, USA. In Canada write to The Eureka Company, 866 Langs Drive, Cambridge, Ontario N3H 2N7. Refer to The Eureka Warranty for complete service information.



DO NOT OIL the motor at any time. The bearings are permanently lubricated and sealed.

Rating Plate

The model, type, and serial numbers are indicated on the rating plate located on the back side of the cleaner. For prompt and complete service information, always refer to these numbers when inquiring about service.

MODEL	TYPE	SERIAL NO.
VOLTS	AMPS.	HERTZ
SERVICE INFORMATION: 1-800-282-2886		
THE EUREKA COMPANY BLOOMINGTON, ILLINOIS 61701		

Model & Type _____ **Serial No.** _____

Automatic Motor Shut-Off

To protect from overheating, this vacuum cleaner is equipped with a thermostat which automatically shuts off the motor if it overheats. Should this happen:

1. **Turn off the switch and unplug the cleaner** because the thermostat will allow the cleaner to automatically start running again when the motor cools (approximately 30 minutes).
2. **Check the hose, bag and filter** regularly, as a clogged hose, full bag or dirty filter could cause the motor to overheat.
3. **Call a Eureka Service Station** if the cleaner will not operate after cooling for approximately 30 minutes.

HOW TO USE

CAUTION: Moving parts. Make sure on/off switch is in off position before plugging in.

A carpet should be cleaned regularly over heavily traveled areas, and once a week over the entire carpeted area. Vacuum slowly, making several passes (forward and backward) over the carpet, covering small areas at a time. The time required to clean the carpet will depend on several factors – including type of carpet and amount of dirt.

1 Connect Hose

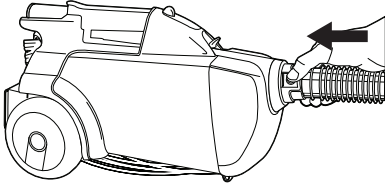

2 Rotate Swivel Hook to release cord

3 Plug in

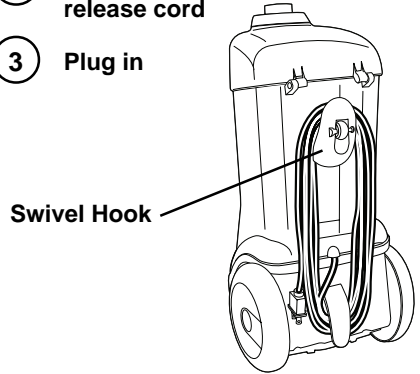

4 Store Tools

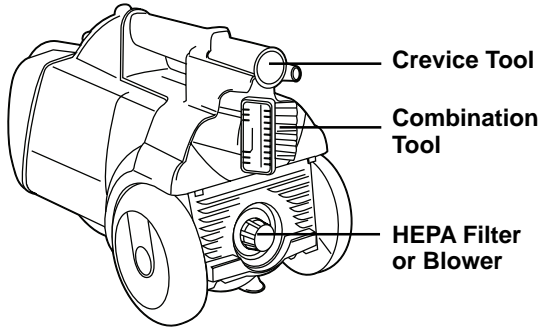

5 Push ON/OFF Switch (A thermostat automatically shuts the motor off if it overheats, see Automatic Motor Shut-Off)

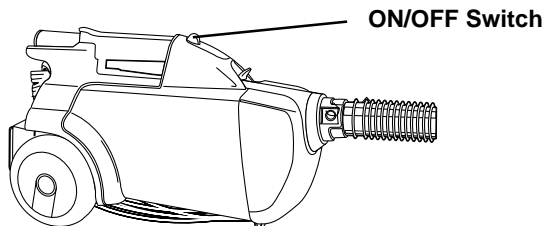

Cleaning Accessories

Attach wands and cleaning tools

Slip the circular end of an accessory tool onto the end of the hose handle and twist slightly to secure. If additional reach is needed, place a wand on the hose handle first.

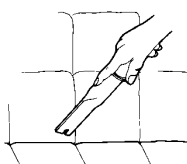
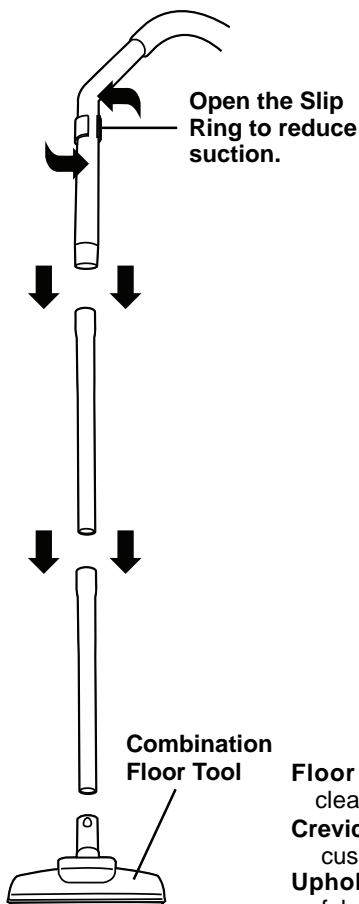

Crevice Tool

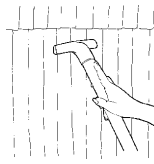

***Upholstery Nozzle (optional)**

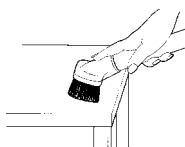

***Dusting Brush (optional)**

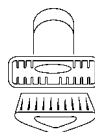

Combination Tool

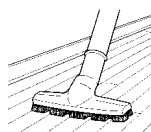

***Bare Floor Brush (optional)**

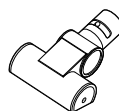

***Floor Nozzle**

Floor Nozzle (on some models): For effective floor cleaning. i.e. stair treads and furniture.

Crevice Tool: For crevices, corners, baseboards, between cushions.

Upholstery Nozzle: For curtains, draperies, cushions, fabrics.

Dusting Brush: For furniture, blinds, books, lamp shades, shelves.

Combination Tool: One tool with bristles for dusting, and nozzle for floors and upholstery.

Bare Floor Brush: For any type of hard surface floor.

*May be purchased separately.

Blower

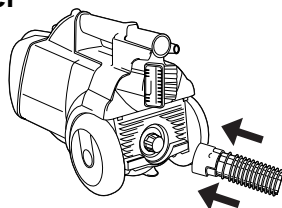

To use the blower feature, turn the cleaner off. Remove the hose from the hose inlet at the front of the cleaner. Place the hose firmly into the blower at the back of the cleaner. This feature is useful for cleaning blockages out of the hose.

The blower feature is not available on cleaners with the HEPA filter feature.

HOW TO MAINTAIN

The instructions given in this booklet serve as a guide to routine maintenance. To avoid unnecessary service calls, check the hose, dust cup and filters often. Clear a clogged hose with the blower, empty the dust cup if it is full, and clean or replace the filters when dirty.

How to Remove Dust Cup and Empty Dust Cup

NOTE: Turn off vacuum and unplug the electrical cord before changing dust bag or cleaning filters. Never operate the vacuum cleaner without the dust bag or filters.

- 1 Turn off and unplug cleaner.
- 2 Open canister hood by pushing down hood latch and lifting up on lid.

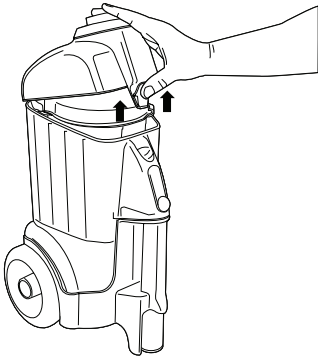

- 3 Lift dust cup out of canister by handle.

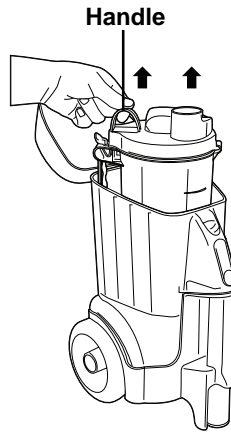

- 4 Release latch and tilt dust cup lid. Pull dust cup lid back towards handle to release. Pull dust cup up to remove from dust cup.

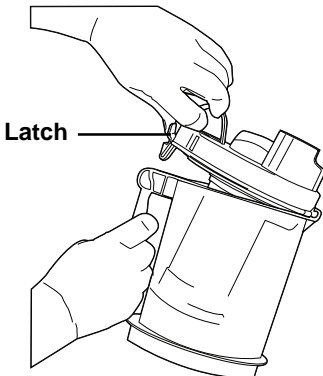

- 5 Empty dust cup over trash receptacle. To replace dust cup in canister follow these instructions in reverse.

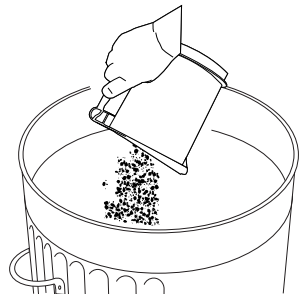

Disposable Filters

The filters play a very important roll in the efficiency of the vacuum cleaner. If the filters become clogged, no air can pass through the cleaner and no cleaning can take place regardless of how powerful the unit is. To keep the cleaner operating at maximum efficiency, change or clean the filters as needed. Some fine particles can restrict airflow very quickly and will decrease performance even before the filters appear to be dirty. For that reason, when vacuuming carpet fresheners or cleaners, powder, plaster dust, or similar fine substances, the filters may need to be changed more often.

Look for the  symbol.

How to Check and Replace Disposable Dust Cup Filter

NOTE: Turn off vacuum and unplug the electrical cord before changing dust bag or cleaning motor filter. Never operate the vacuum cleaner without the dust bag or filter.

- 1 Follow the directions on the previous page on how to remove the dust cup from the canister.
- 2 Release latch and tilt dust cup lid. Pull dust cup lid back towards handle to release. Pull dust cup up to remove from dust cup.
- 3 Grasp orange filter frame and twist counter clockwise to remove.

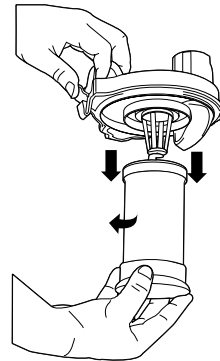
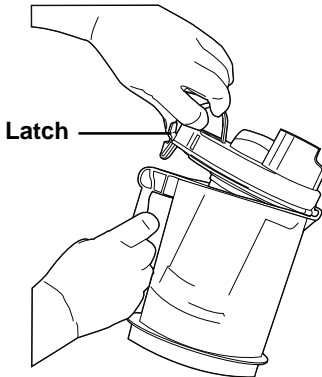

- 4 Shake filter vigorously and brush off dust and lint. If filter needs further cleaning, wash in warm water using a mild detergent.
- 5 When all parts are completely dry, replace filter on gray dust cup lid by twisting clockwise to snap and lock in place.
- 6 Reinstall dust cup by following the above directions in reverse.

CAUTION: Dust cup lid and filter are not dishwasher safe.

CAUTION: Do not submerge gray dust cup lid, wipe only with a damp cloth.

How to Clean or Replace Motor Filter

- 1 Turn off and unplug cleaner.
- 2 Open lid by pushing down hood latch and lifting up on lid.
- 3 Lift dust cup out of canister by handle.
- 4 Locate motor filter in bottom of canister body and lift out.
- 5 Clean motor filter by rinsing under warm water and let air dry if heavily soiled.
- 6 Reinstall completely dry motor filter before use.

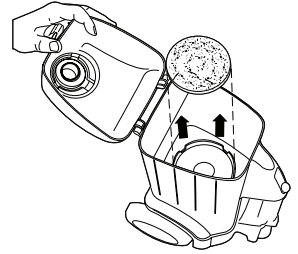
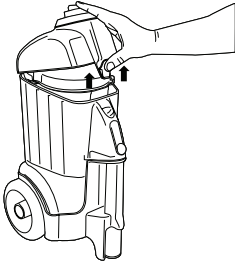

How to Install HEPA Filter (on some models)

Check the HEPA filter each time the dust cup is emptied. Replace twice a year or as needed.

Upper Filter Tabs

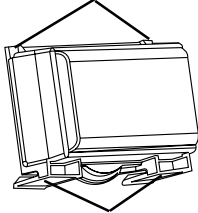

Bottom Clips

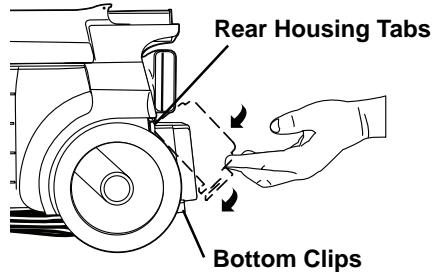

Insert upper filter corner tabs firmly under rear housing tabs and pivot filter down until bottom clips on filter click securely into place on the cleaner.

How to Remove HEPA Filter

Grasp the bottom clips on the filter and pull out and down to release the upper filter tabs from the rear housing tabs on the cleaner.

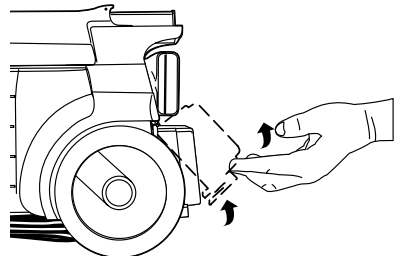

PROBLEM SOLVING

NOTE: Turn OFF the power switch and unplug the electrical cord before servicing.

PROBLEM	CAUSE	SOLUTION
Motor won't start	<input checked="" type="checkbox"/> Electric plug <input checked="" type="checkbox"/> Power switch not turned "ON"	<input type="checkbox"/> Push plug securely into outlet. <input type="checkbox"/> Try another outlet. <input type="checkbox"/> Check circuit breaker. <input type="checkbox"/> Make sure power switch is "ON."
No suction at end of hose	<input checked="" type="checkbox"/> Full dust cup <input checked="" type="checkbox"/> Hose <input checked="" type="checkbox"/> Clogged or dirty filter. <input checked="" type="checkbox"/> Canister lid not latched	<input type="checkbox"/> Empty dust cup. <input type="checkbox"/> Remove any clogs from hose that restrict airflow, then try again. <input type="checkbox"/> Check filter. If dirty, clean or replace with a new filter. <input type="checkbox"/> Push canister lid until it latches firmly.
Reduced suction	<input checked="" type="checkbox"/> Full dust cup <input checked="" type="checkbox"/> Slip ring open <input checked="" type="checkbox"/> Hose <input checked="" type="checkbox"/> Clogged or dirty filter.	<input type="checkbox"/> Empty dust cup. <input type="checkbox"/> Rotate slip ring on wand until hole is covered. <input type="checkbox"/> Remove any clogs from hose that restrict airflow, then try again. <input type="checkbox"/> Check filter. If dirty, clean or replace with a new filter.
Cleaner shuts off	<input checked="" type="checkbox"/> Internal safety thermostat trips	<input type="checkbox"/> Unplug cleaner and check for obstructions in hose, wands and attachments. <input type="checkbox"/> Check for full dust cup.
General questions	<input checked="" type="checkbox"/> Assembly or related attachments	<input type="checkbox"/> Call 1-800-282-2886 between 7:00 AM-8:00PM central standard time. <input type="checkbox"/> Know the Model number and Serial number when you call.

THE EUREKA LIMITED WARRANTY

What This Warranty Covers

Your Eureka cleaner is warranted to be free from all defects in material and workmanship in normal household use for a period of one year. The warranty is granted only to the original purchaser and members of his or her immediate household. The warranty is subject to the following provisions.

What This Warranty Does Not Cover

- Parts of the cleaner that require replacement under normal use, such as disposable dust bags, filters, drive belts, light bulbs, and brush roll bristles
- Damages or malfunctions caused by negligence, abuse, or use not in accordance with the Owner's Guide.
- Defects or damages caused by unauthorized service or the use of other than Genuine Eureka parts.

What The Eureka Company Will Do

The Eureka Company will, at its option, repair or replace a defective cleaner or cleaner part that is covered by this warranty. As a matter of warranty policy, the Eureka Company will not refund the consumer's purchase price.

Warranty Registration

Please fill out and return the warranty registration card accompanying your cleaner.

Obtaining Warranty Service

To obtain warranty service you must return the defective cleaner or cleaner part along with proof of purchase to any Eureka Authorized Warranty Station. You will find the nearest location in the Yellow Pages, under "Vacuum Cleaners—Service and Repair." Be certain that the Warranty Station is "Eureka Authorized." For the location of the nearest Eureka Authorized Warranty Station or for service information, telephone toll free:

USA: 1-800-282-2886

Mexico: 5670-6169

Canada: 1-800-282-2886

If you prefer, you can write to The Eureka Company, Service Division, 807 North Main Street, Bloomington, Illinois 61701, USA. In Canada write to The Eureka Company, 866 Langs Drive, Cambridge, Ontario N3H 2N7.

If it is necessary to ship the cleaner outside your community to obtain warranty repair, you must pay the shipping charges to the Eureka Authorized Warranty Station. Return shipping charges will be paid by the Warranty Station. When returning parts for repair, please include the model, type, and serial numbers from the data plate on the cleaner.

Further Limitations and Exclusions

Any warranty that may be implied in connection with your purchase or use of the cleaner, including any warranty of Merchantability or any warranty for Fitness For A Particular Purpose is limited to the duration of this warranty. Some states do not allow limitations on how long an implied warranty lasts, so the above limitations may not apply to you.

Your relief for the breach of this warranty is limited to the relief expressly provided above. In no event shall Eureka be liable for any consequential or incidental damages you may incur in connection with your purchase or use of the cleaner. Some states do not allow the exclusion or limitation of incidental or consequential damages, so the above limitation or exclusion may not apply to you.

This warranty gives you specific legal rights. You may also have other rights which vary by state.



Questions & Answers about Genuine Eureka Products

- Q:** Why should I use only Genuine Eureka paper bags, belts, and parts in my Eureka vacuum cleaner?
A: Using Genuine Eureka Products, which are made to our exacting specifications and engineered with emphasis on quality, performance, and customer satisfaction, ensures the long life and cleaning efficiency of your vacuum cleaner. Overall, this saves you money and helps to keep your home clean.
- Q:** How can I be sure I am using only genuine Eureka products in my vacuum cleaner?
A: Typically, packaged products and paper bags can be identified by a "Genuine Eureka Product" symbol (see illustration above). For further identification assistance, you may call our toll-free number, 1-800-282-2886, for the location of a nearby Eureka Authorized Warranty Station.
- Q:** Are there any differences between "made to fit" or "imitation" and Genuine Eureka paper bags, belts, and parts?
A: Yes, there are some very important differences in materials, quality, and reliability. Many customers have mistakenly purchased "imitation" paper bags and parts while thinking they purchased genuine. Unfortunately, many of these customers discovered the differences after they experienced related difficulties.

**For Genuine Eureka Value, Accept No Limitations!
THE EUREKA COMPANY**

Bloomington, Illinois 61701

Household Warranty
abs 190