

GoldStar

Website: <http://www.LGService.com>
E-mail: <http://www.LGService.com/techsup.html>

MICROWAVE OVEN SERVICE MANUAL

MODEL: MS-104YC

CAUTION

BEFORE SERVICING THE UNIT, READ THE
SAFETY PRECAUTIONS IN THIS MANUAL.

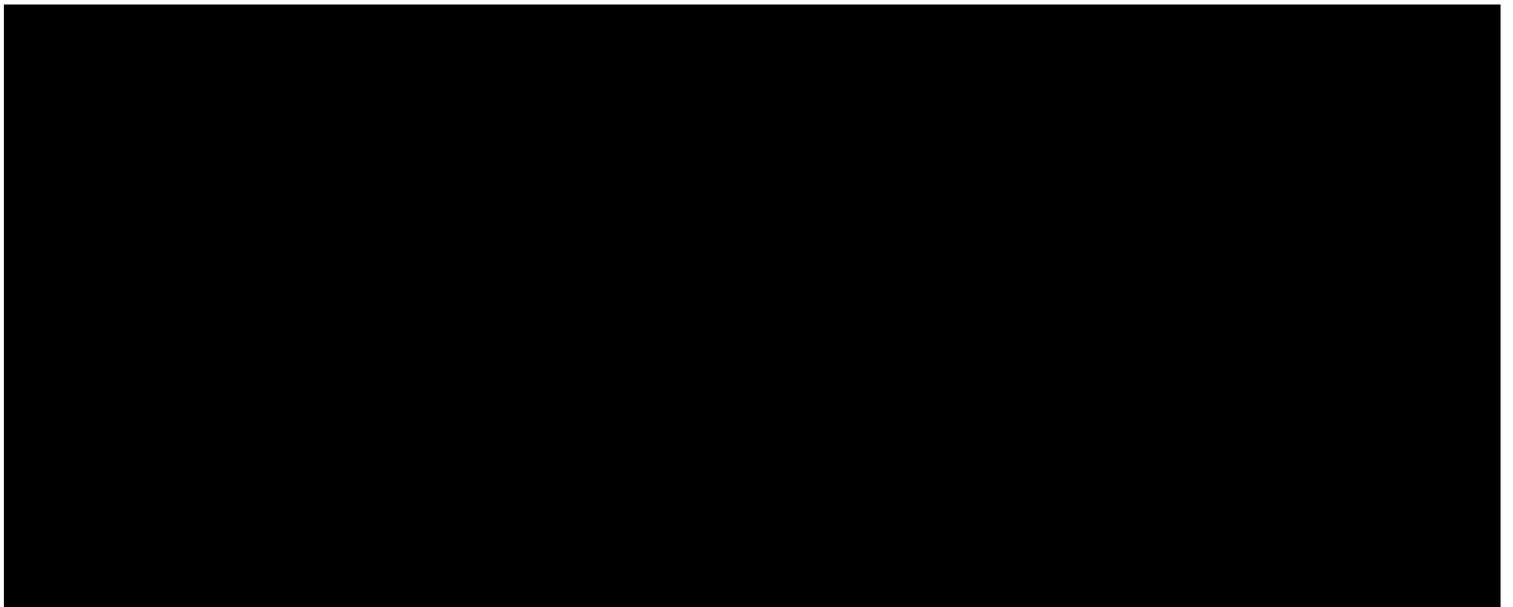
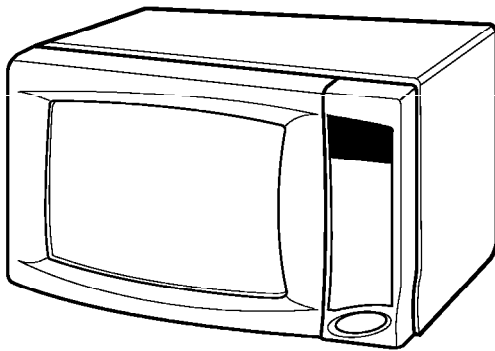

SAFETY PRECAUTIONS

This device is to be serviced only by properly qualified service personnel.

Consult the service manual for proper service procedures to assure continued safety operation and for precautions to be taken to avoid possible exposure to excessive microwave energy.

PRECAUTIONS TO BE OBSERVED BEFORE AND DURING SERVICING TO AVOID POSSIBLE EXPOSURE TO EXCESSIVE MICROWAVE ENERGY

- A) Do not operate or allow the oven to be operated with the door open.
- B) Make the following safety checks on all ovens to be serviced before activating the magnetron or other microwave source, and make repairs as necessary; (1) interlock operation, (2) proper door closing, (3) seal and sealing surfaces (arcing, wear, and other damage), (4) damage to or loosening of hinges and latches, (5) evidence of dropping or abuse.
- C) Before turning on microwave power for any service test or inspection within the microwave generating compartments, check the magnetron, wave guide or transmission line, and cavity for proper alignment, integrity, and connections.
- D) Any defective or misadjusted components in the interlock, monitor, door seal, and microwave generation and transmission systems shall be repaired, replaced, or adjusted by procedures described in this manual before the oven is released to the owner.
- E) A microwave leakage check to verify compliance with the CSA should be performed on each oven prior to release to the owner.

CONTENTS

(Page)

SAFETY PRECAUTIONS	Inside front cover
SPECIFICATIONS	1-1
CAUTIONS	2-1
INSTALLATIONS	3-1
OPERATING INSTRUCTIONS	4-1
FEATURES.....	4-1
CONTROL PANEL	4-1
OPERATING SEQUENCE.....	4-2
SCHEMATIC DIAGRAM	4-3
CIRCUIT DESCRIPTION	4-4
SERVICE INFORMATION	5-1
TOOLS AND MEASURING INSTRUMENTS	5-1
MICROWAVE LEAKAGE TEST	5-1
MEASUREMENT OF MICROWAVE POWER OUTPUT	5-3
DISASSEMBLY AND ADJUSTMENT	5-3
INTERLOCK CONTINUITY TEST.....	5-8
COMPONENT TEST PROCEDURE	5-9
TROUBLE SHOOTING	5-12
EXPLODED VIEW	6-1
REPLACEMENT PARTS LIST	7-1
SCHEMATIC DIAGRAM OF P.C.B.	8-1
PRINTED CIRCUIT BOARD.....	8-2
P.C.B. PARTS LIST	9-1

SPECIFICATIONS

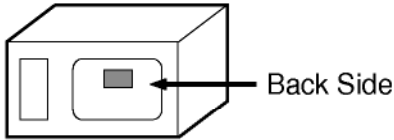
ITEM	DESCRIPTION
MODEL	MS-104YC
Power Requirement	120 Volts AC 60 Hz 1,500 Watts (13.0A) Single phase, 3 wire grounded
Power Output	1100 Watts full microwave power (IEC705)
Microwave Frequency	2,450 MHz
Magnetron	2M248/2M246
Timer	0 ~ 99 min. 99 sec.
Outside Dimensions	20 ¹ / ₈ " (W) x 12" (H) x 14 ¹ / ₂ " (D)
Cavity Dimensions	13" (W) x 9" (H) x 14 ¹ / ₄ " (D)
Net Weight	32 lbs (approx.)
Shipping weight	35 lbs (approx.)
Control Complement	Touch Control System Clock : 1:00 - 12:59 Microwave Power for Variable Cooking Power level HIGH ----- Full power throughout the cooking time 9 (Saute) ----- approx. 90% of Full power, 8 (Reheat) ----- approx. 80% 7 (Med.-High) ----- approx. 70%, 6 (Medium) ----- approx. 60% 5 (Med.-Low) ----- approx. 50%, 4 (Defrost) ----- approx. 40% 3 (Low) ----- approx. 30%, 2 (Simmer) ----- approx. 20% 1 (Warm) ----- approx. 10%
Nameplate Location	
Accessories	Owner's manual & cooking guide Glass turntable Rotating ring
<p>This microwave oven is designed for household use only. It is not recommended for commercial purposes.</p>	

CAUTIONS

Unlike other appliances, the microwave oven is high-voltage and high-current equipment. Though it is free from danger in ordinary use, extreme care should be taken during repair.

- DO NOT operate on a 2-wire extension cord during repair and use.
- NEVER TOUCH any oven components or wiring during operation.
- BEFORE TOUCHING any parts of the oven, always remove the power plug from the outlet.
- For about 30 seconds after the oven stops, an electric charge remains in the high voltage capacitor. When replacing or checking, you must discharge the high voltage capacitor by shorting across the two terminals with an insulated screwdriver.

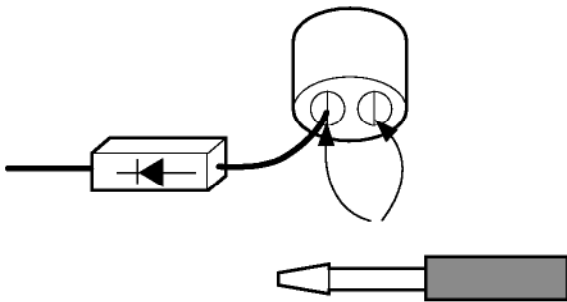

- Remove your watches whenever working close to or replacing the Magnetron.
- DO NOT touch any parts of the control panel circuit. A resulting static electric discharge may damage this P.C.B.
- NEVER operate the oven with no load.
- NEVER injure the door seal and front plate of the oven cavity.
- NEVER put iron tools on the magnetron.
- NEVER put anything into the latch hole and the interlock switches area.

MICROWAVE RADIATION

Personnel should not be exposed to the microwave energy which may radiate from the magnetron or other microwave generating device if it is improperly used or connection. All input and output microwave connections, waveguide, flange, and gasket must be secure never operate the device without a microwave energy absorbing load attached. Never look into an open waveguide or antenna while the device is energized.

- Proper operation of the microwave oven requires that the magnetron be assembled to the waveguide and cavity. Never operate the magnetron unless it is properly installed.
- **Be sure that the magnetron gasket is properly installed around the dome of the tube whenever installing the magnetron.**

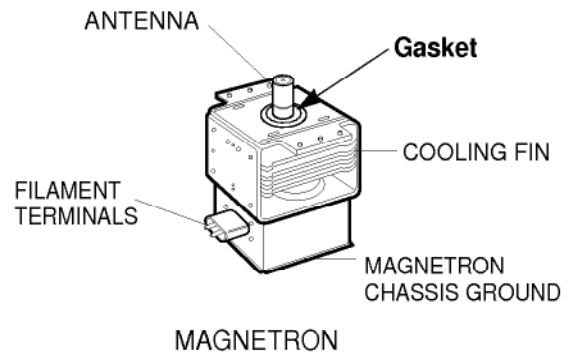

THE OVEN IS TO BE SERVICED ONLY BY PROPERLY QUALIFIED SERVICE PERSONNEL.

INSTALLATIONS

BEFORE YOU BEGIN, READ THE FOLLOWING INSTRUCTIONS COMPLETELY AND CAREFULLY.

INSTALLING

1. Empty the microwave oven and clean inside it with a soft, damp cloth. Check for damage such as misaligned door, damage around the door or dents inside the cavity or on the exterior.
2. Put the oven on a counter, table, or shelf that is strong enough to hold the oven and the food and utensils you put in it. (The control panel side of the oven is the heavy side. Use care when handling.)
3. Do not block the vent and the air intake openings. Blocking vent or air intake openings can cause damage to the oven and poor cooking results. Make sure the microwave oven legs are in place to ensure proper air flow.
4. The oven should not be installed in any area where heat and steam are generated, because they may damage the electronic or mechanical parts of the unit. Do not install the oven next to a conventional surface unit or above a conventional wall oven.
5. Use microwave oven in an ambient temperature less than 104°F(40°C).
6. Place the microwave oven on a sturdy and flat surface at least 10 cm(4 inches) from the wall.
7. Place the microwave oven as far away as possible from TV, RADIO, COMPUTER, etc., to prevent interference.

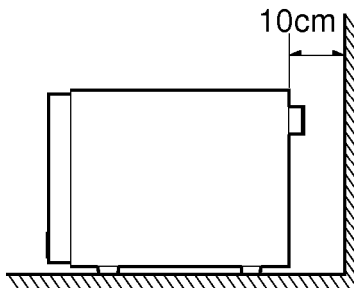

GROUNDING INSTRUCTIONS

For personal safety, this appliance must be fully grounded at all times.

In the event of an electrical short circuit, grounding reduces the risk of electrical shock.

The plug must be plugged into an outlet that is properly installed and grounded.

WARNING

Improper use of the grounding plug can result in a risk of electric shock.

Do not, under any circumstances, cut or remove the third ground prong from the power cord plug.

PREFERRED METHOD

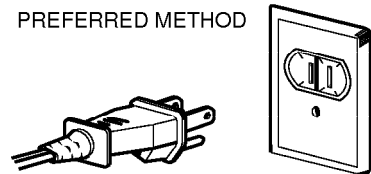

ENSURE PROPER GROUND EXISTS BEFORE USE

TEMPORARY METHOD
(ADAPTER PLUGS NOT PERMITTED IN CANADA)

ALIGN LARGE PRONGS/SLOTS

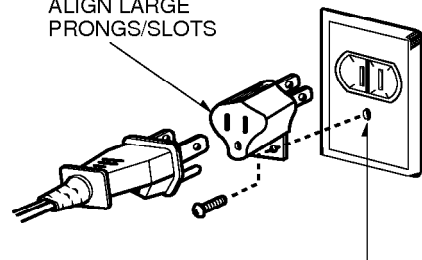

ENSURE PROPER GROUND AND FIRM CONNECTION BEFORE USE

OPERATING INSTRUCTIONS

FEATURES

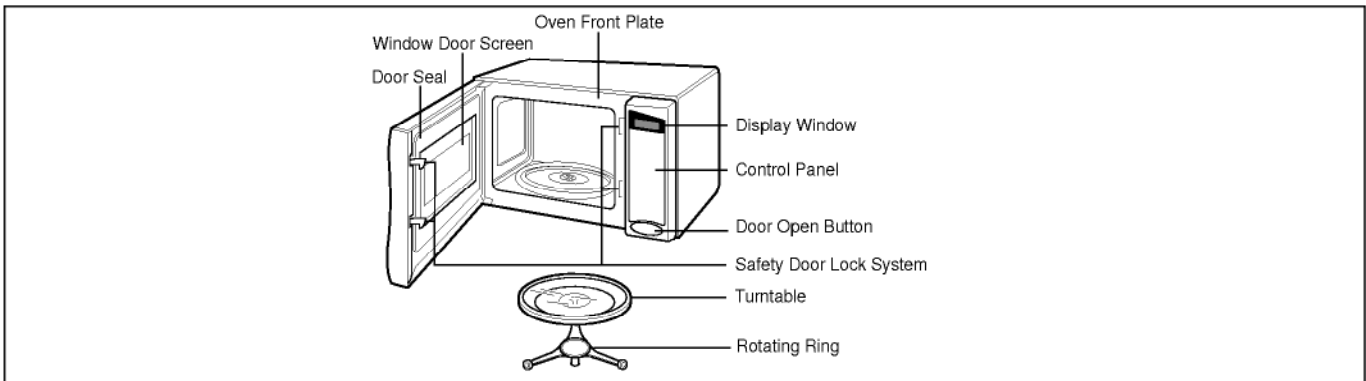

CONTROL PANEL

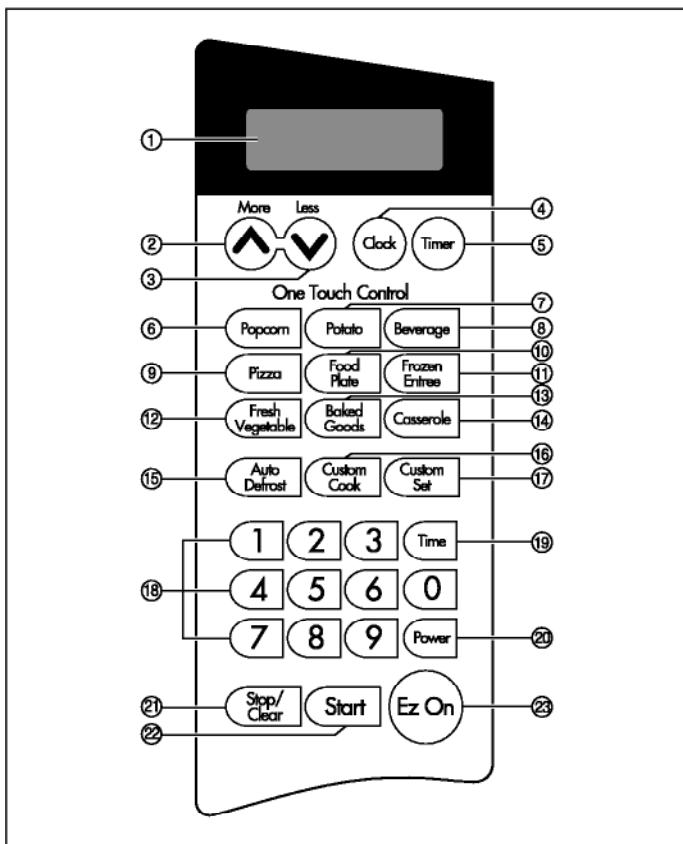

6. **ONE TOUCH POPCORN** : Touch this pad to pop a bag of microwave popcorn without entering a cook power or time.
7. **ONE TOUCH POTATO** : Touch this pad to cook up to 4 potatoes without entering a cook power or time.
8. **ONE TOUCH BEVERAGE** : Touch this pad to heat up to 2 cups of beverage without entering a cook power or time.
9. **ONE TOUCH PIZZA** : Touch this pad to heat up to 3 slices of **refrigerated** pizza without entering a cook power or time.
10. **ONE TOUCH FOOD PLATE** : Touch this pad to heat a plate of food without entering a cook power or time.
11. **FROZEN ENTREE** : Touch this pad to cook a 10 oz. frozen entrée without entering a cook power or time.
12. **FRESH VEGETABLE** : Touch this pad to cook fresh vegetables without entering a cook power or time.
13. **BAKED GOODS** : Touch this pad to heat up to 4 items without entering a cook power or time.
14. **CASSEROLE** : Touch this pad to heat up to 4 cups of casserole without entering a cook power or time.
15. **AUTO DEFROST**: Touch this pad to meat, poultry, or fish by entering a weight.
16. **CUSTOM COOK** : Touch this pad to set and execute frequently-used, single-stage cooking programs.
17. **CUSTOM SET** : Touch this pad to select sound Off or On, Auto Off or On, Lbs/kg.
18. **NUMBER PADS** : Touch number pads to enter cooking time, power level, quantities, or weights.
19. **TIME** : Touch this pad to set a cooking time.
20. **POWER** : Touch this pad to set a cooking power.
21. **STOP/CLEAR** : Touch this pad to stop the oven or clear entries.
22. **START** : Touch this pad to start all entries (except the ONE TOUCH and EZ ON functions, which start automatically).
23. **EZ ON** : Touch this pad to cook at 100% cook power for 30 seconds to 99 minutes, 59 seconds.

1. **DISPLAY** : The display includes a clock and indicators that tell you time of day, cooking time settings, and cooking functions selected.
2. **MORE** : Each time you touch this pad, you add 10 seconds to the cooking time.
3. **LESS** : Each time you touch this pad, you subtract 10 seconds from the cooking time.
4. **CLOCK** : Touch this pad to enter the time of day.
5. **TIMER** : Touch this pad to use your microwave oven as a kitchen timer.

OPERATING SEQUENCE

The following is a description of component functions during oven operation.

1. SETTING THE CLOCK

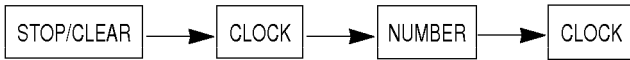

ex.) To set 4:30, touch number key [4],[3], and [0].

NOTE: 1) This is a 12 hour clock.

2) Clock will operate as long as power is applied to the oven.

2. CANCEL FUNCTION

Touch the **STOP/CLEAR** pad whenever you need to cancel an entry or a function currently in use.

The display will either return to the last item entered or to the clock.

3. EZ ON

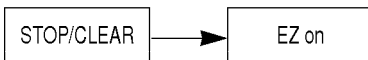

4. ONE TOUCH CONTROL



NOTE: Heat only 1 package at a time

5. TIME COOKING

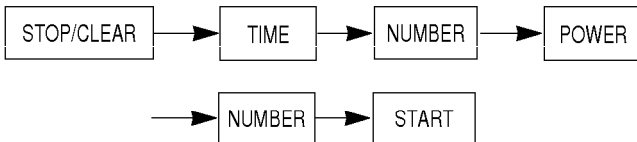

6. MULTI-STAGE COOKING

1ST STAGE

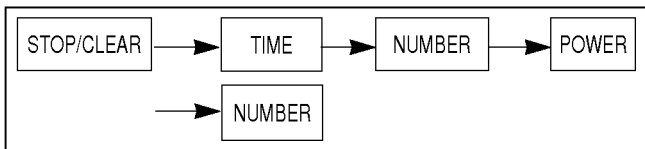

2ND STAGE

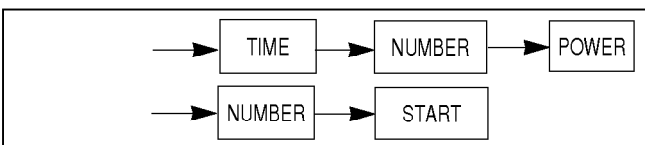

7. AUTO DEFROST COOKING



8. CHILD LOCK

This oven has a CHILD LOCK feature

TO SET CHILD LOCK

- Touch the **STOP/CLEAR** pad
- Touch and hold **"0"** pad → **LOCK** appear on the display.

TO CANCEL CHILD LOCK

- Touch the **STOP/CLEAR** pad
- Touch and hold **"0"** pad → **LOCK** disappears on the display.

9. MORE / LESS

The cook time is adjustable by MORE pad or LESS pad

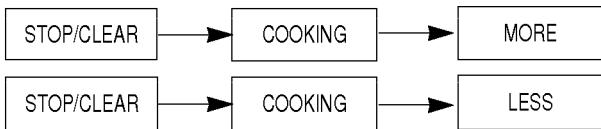

10. CUSTOM COOK

You can program the cook time and power level by using CUSTOM COOK pad.

ex) To set cook time 10 mine 30seconds, touch number key [1],[0],[3], and [0]

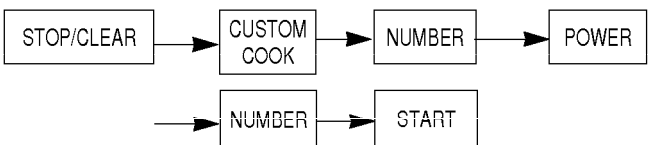

11. CUSTOM SET

You can program your microwave oven to turn the sound and clock on or off, adjust the scroll speed of the display, switch between pounds and kilograms, and demonstration on or off.

TOUCH KEYPAD	CHOICE
1	Sound On or Sound Off
2	Auto On/Off
3	Lbs or Kg

NOTE: When the power cord is first plugged in the default settings are; Sound On, Auto On, Normal Speed, Lbs.

SCHEMATIC DIAGRAM

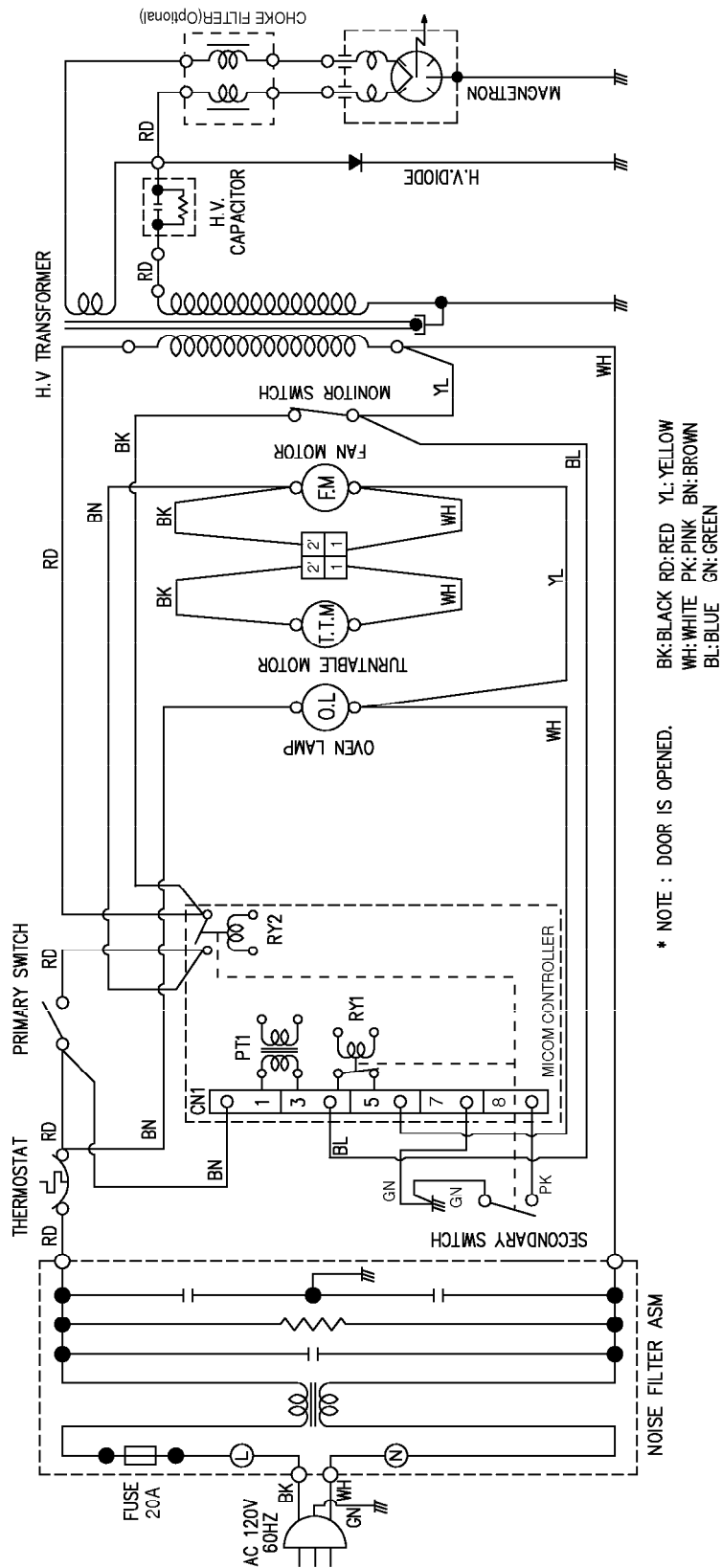

* NOTE : DOOR IS OPENED.
 BK:BLACK RD:RED YL:YELLOW
 WH:WHITE PK:PINK BN:BROWN
 BL:BLUE GN:GREEN

IMPORTANT SAFETY NOTE: THE SHADED AREAS ON THIS SCHEMATIC DIAGRAM INCORPORATE SPECIAL FEATURES IMPORTANT FOR PROTECTION FROM MICROWAVE RADIATION, FIRE, ELECTRICAL SHOCK, AND HAZARDS. WHEN SERVICING IT IS ESSENTIAL THAT ONLY MANUFACTURER'S SPECIFIED PARTS BE USED FOR THE CRITICAL COMPONENTS IN THE SHADED AREAS OF THE SCHEMATIC DIAGRAM.

NOTICE: SINCE THIS IS BASIC SCHEMATIC DIAGRAM, THE VALUES OF COMPONENTS AND SOME PARTIAL CONNECTIONS ARE SUBJECT TO CHANGE FOR IMPROVEMENT.

CIRCUIT DESCRIPTION

GENERAL DETAILS

- The low voltage transformer supplies the necessary voltage to the micom controller when power cord is plugged in.
- When the door is closed, the primary switch is ON, the secondary switch is ON, and the monitor switch opens (contact COM and NO).

WHEN SELECTING COOKING POWER LEVEL AND TIME

- The micom controller memorizes the function you set.
- The time you set appears in the display window.
- Each indicator light turns on to indicate that the stage has been set.

WHEN TOUCHING THE START PAD

- The coil of the relay is energized by the micom controller.
- Power input is supplied to the high voltage transformer through the fuse to the primary switch and relay 2.
- Turntable rotates.

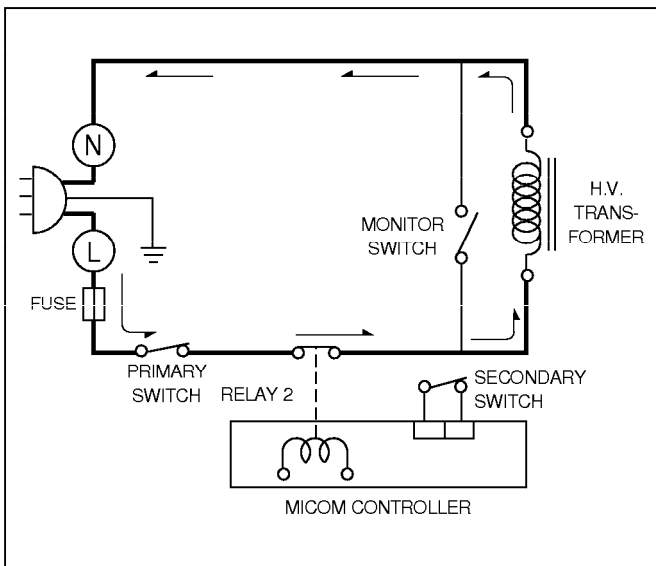

- The fan motor rotates and cools the magnetron by blowing the air (coming from the intake on the base-plate).
- The air is also directed into the oven to exhaust the vapor in the oven through the upper plate.
- Cooking time starts counting down.
- 3.3 volts AC is generated from the filament winding of the high voltage transformer. This 3.3 volts is applied to the magnetron to heat the magnetron filament through two noise-preventing choke coils.

- A high voltage of approximately 2100 volts AC is generated in the secondary of the high voltage transformer which is increased by the action of the high voltage diode and charging of the high voltage capacitor.
- The negative 4,000 Volts DC is applied to the filament of the magnetron.

WHEN THE OVEN IS SET AT ANY LEVEL EXCEPT MAXIMUM.

- The micom controller controls the ON-OFF time of relay 2 by the applied signal to vary the average output power of microwave oven as POWER LEVEL. (refer to page 1-1)
- One complete cycle of relay 2 is 22 seconds.

WHEN THE DOOR IS OPENED DURING COOKING

- Both the primary switch and relay 2 cut off the primary winding voltage of the high voltage transformer.
- ON-OFF of relay 2 is coupled electrically with opening and closing of the secondary switch.
- When the door is opened, the secondary switch is opened and when the door is closed, the secondary switch is closed.
- The cooking time stops counting down.
- Relay stops functioning.
- As the door is opened, if the contact of primary switch and relay 2 and/or secondary switch fail to open, the fuse opens due to the large current surge caused by the monitor switch activation, which in turn stops magnetron oscillation.

