

# GoldStar

<http://www.LGService.com>  
E-mail:Techsupport@LGService.com

# MICROWAVE OVEN SERVICE MANUAL

**MODEL : MS-114SA**

**CAUTION**

BEFORE SERVICING THE UNIT, READ THE  
SAFETY PRECAUTIONS IN THIS MANUAL.

# **SAFETY PRECAUTIONS**

This device is to be serviced only by properly qualified service personnel.

Consult the service manual for proper service procedures to assure continued safety operation and for precautions to be taken to avoid possible exposure to excessive microwave energy.

## **PRECAUTIONS TO BE OBSERVED BEFORE AND DURING SERVICING TO AVOID POSSIBLE EXPOSURE TO EXCESSIVE MICROWAVE ENERGY**

- A) Do not operate or allow the oven to be operated with the door open.
- B) Make the following safety checks on all ovens to be serviced before activating the magnetron or other microwave source, and make repairs as necessary; (1) interlock operation, (2) proper door closing, (3) seal and sealing surfaces (arcing, wear, and other damage), (4) damage to or loosening of hinges and latches, (5) evidence of dropping or abuse.
- C) Before turning on microwave power for any service test or inspection within the microwave generating compartments, check the magnetron, wave guide or transmission line, and cavity for proper alignment, integrity, and connections.
- D) Any defective or misadjusted components in the interlock, monitor, door seal, and microwave generation and transmission systems shall be repaired, replaced, or adjusted by procedures described in this manual before the oven is released to the owner.
- E) A microwave leakage check to verify compliance with the CSA should be performed on each oven prior to release to the owner.

# CONTENTS

(Page)

<b>SAFETY PRECAUTIONS</b> .....	<b>Inside front cover</b>
<b>SPECIFICATIONS</b> .....	<b>1-1</b>
<b>CAUTIONS</b> .....	<b>2-1</b>
<b>INSTALLATIONS</b> .....	<b>3-1</b>
<b>OPERATING INSTRUCTIONS</b> .....	<b>4-1</b>
FEATURES.....	4-1
CONTROL PANEL .....	4-1
OPERATING SEQUENCE.....	4-2
SCHEMATIC DIAGRAM .....	4-3
CIRCUIT DESCRIPTION .....	4-4
<b>SERVICE INFORMATION</b> .....	<b>5-1</b>
TOOLS AND MEASURING INSTRUMENTS.....	5-1
MICROWAVE LEAKAGE TEST .....	5-1
MEASUREMENT OF MICROWAVE POWER OUTPUT .....	5-3
DISASSEMBLY AND ADJUSTMENT.....	5-3
INTERLOCK CONTINUITY TEST.....	5-7
COMPONENT TEST PROCEDURE .....	5-8
TROUBLE SHOOTING .....	5-11
<b>EXPLODED VIEW</b> .....	<b>6-1</b>
<b>REPLACEMENT PARTS LIST</b> .....	<b>7-1</b>
<b>SCHEMATIC DIAGRAM OF P.C.B.</b> .....	<b>8-1</b>
PRINTED CIRCUIT BOARD.....	8-2
<b>P.C.B. PARTS LIST</b> .....	<b>9-1</b>

# SPECIFICATIONS

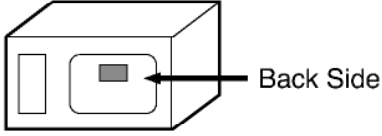
ITEM	DESCRIPTION
<b>MODEL</b>	<b>MS-114SA</b>
Power Requirement	120 Volts AC 60 Hz 1,500 Watts Single phase, 3 wire grounded
Power Output	1,100 Watts full microwave power (IEC705)
Microwave Frequency	2,450 MHz
Magnetron	2M246, 2M248J
Timer	0 ~ 99 min. 99 sec.
Outside Dimensions	20 <sup>7</sup> / <sub>8</sub> (W) x 12 <sup>3</sup> / <sub>8</sub> (H) x 15 <sup>1</sup> / <sub>2</sub> (D)
Cavity Dimensions	13 <sup>3</sup> / <sub>4</sub> (W) x 9 <sup>3</sup> / <sub>8</sub> (H) x 14 <sup>3</sup> / <sub>8</sub> (D)
Net Weight	35 lbs (approx.)
Shipping weight	38 lbs (approx.)
Control Complement	Touch Control System Clock : 1:00 - 12:59 Microwave Power for Variable Cooking Power level HIGH -----Full power throughout the cooking time 9 (Saute) -----approx. 90% of Full power,    8 (Reheat) -----approx. 80% 7 (Med.-High)-----approx. 70%,                      6 (Medium) -----approx. 60% 5 (Med.-Low) -----approx. 50%,                      4 (Defrost) -----approx. 40% 3 (Low) -----approx. 30%,                              2 (Simmer)-----approx. 20% 1 (Warm)-----approx. 10%
Nameplate Location	
Accessories	Owner's manual & cooking guide Glass turntable Rotating ring
This microwave oven is designed for household use only. It is not recommended for commercial purposes.	

# CAUTIONS

Unlike other appliances, the microwave oven is high-voltage and high-current equipment. Though it is free from danger in ordinary use, extreme care should be taken during repair.

- DO NOT operate on a 2-wire extension cord during repair and use.
- NEVER TOUCH any oven components or wiring during operation.
- BEFORE TOUCHING any parts of the oven, always remove the power plug from the outlet.
- For about 30 seconds after the oven stops, an electric charge remains in the high voltage capacitor. When replacing or checking, you must discharge the high voltage capacitor by shorting across the two terminals with an insulated screwdriver.

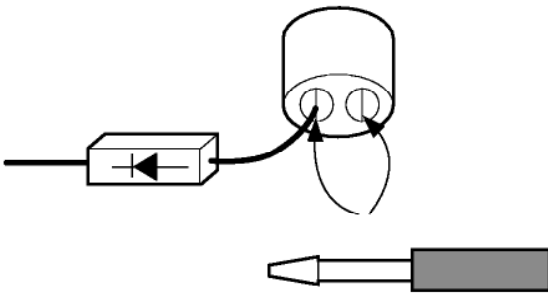

- Remove your watches whenever working close to or replacing the Magnetron.
- DO NOT touch any parts of the control panel circuit. A resulting static electric discharge may damage this P.C.B.
- NEVER operate the oven with no load.
- NEVER injure the door seal and front plate of the oven cavity.
- NEVER put iron tools on the magnetron.
- NEVER put anything into the latch hole and the interlock switches area.

## MICROWAVE RADIATION

Personnel should not be exposed to the microwave energy which may radiate from the magnetron or other microwave generating device if it is improperly used or connection. All input and output microwave connections, waveguide, flange, and gasket must be secure never operate the device without a microwave energy absorbing load attached. Never look into an open waveguide or antenna while the device is energized.

- Proper operation of the microwave oven requires that the magnetron be assembled to the waveguide and cavity. Never operate the magnetron unless it is properly installed.
- **Be sure that the magnetron gasket is properly installed around the dome of the tube whenever installing the magnetron.**

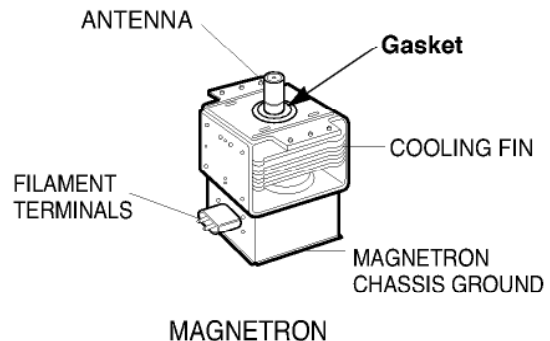

**THE OVEN IS TO BE SERVICED ONLY BY PROPERLY QUALIFIED SERVICE PERSONNEL.**

# INSTALLATIONS

**BEFORE YOU BEGIN, READ THE FOLLOWING INSTRUCTIONS COMPLETELY AND CAREFULLY.**

## INSTALLING

1. Empty the microwave oven and clean inside it with a soft, damp cloth. Check for damage such as misaligned door, damage around the door or dents inside the cavity or on the exterior.
2. Put the oven on a counter, table, or shelf that is strong enough to hold the oven and the food and utensils you put in it. (The control panel side of the oven is the heavy side. Use care when handling.)
3. Do not block the vent and the air intake openings. Blocking vent or air intake openings can cause damage to the oven and poor cooking results. Make sure the microwave oven legs are in place to ensure proper air flow.
4. The oven should not be installed in any area where heat and steam are generated, because they may damage the electronic or mechanical parts of the unit.  
Do not install the oven next to a conventional surface unit or above a conventional wall oven.
5. Use microwave oven in an ambient temperature less than 104°F(40°C).
6. Place the microwave oven on a sturdy and flat surface at least 10 cm(4 inches) from the wall.
7. Place the microwave oven as far away as possible from TV, RADIO, COMPUTER, etc., to prevent interference.

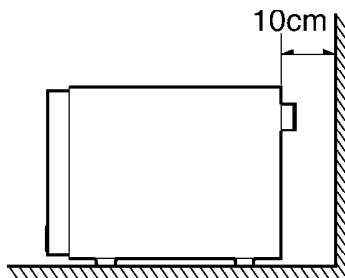

## GROUNDING INSTRUCTIONS

For personal safety, this appliance must be fully grounded at all times.

In the event of an electrical short circuit, grounding reduces the risk of electrical shock.

The plug must be plugged into an outlet that is properly installed and grounded.

### WARNING

Improper use of the grounding plug can result in a risk of electric shock.

Do not, under any circumstances, cut or remove the third ground prong from the power cord plug.

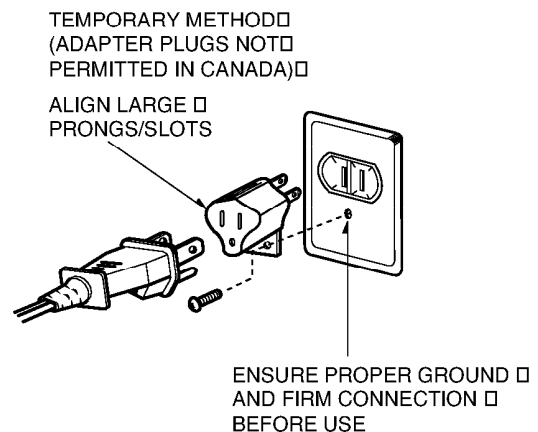
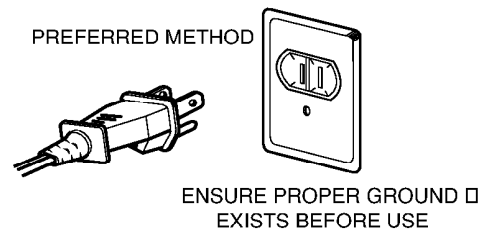

# OPERATING INSTRUCTIONS

## FEATURES

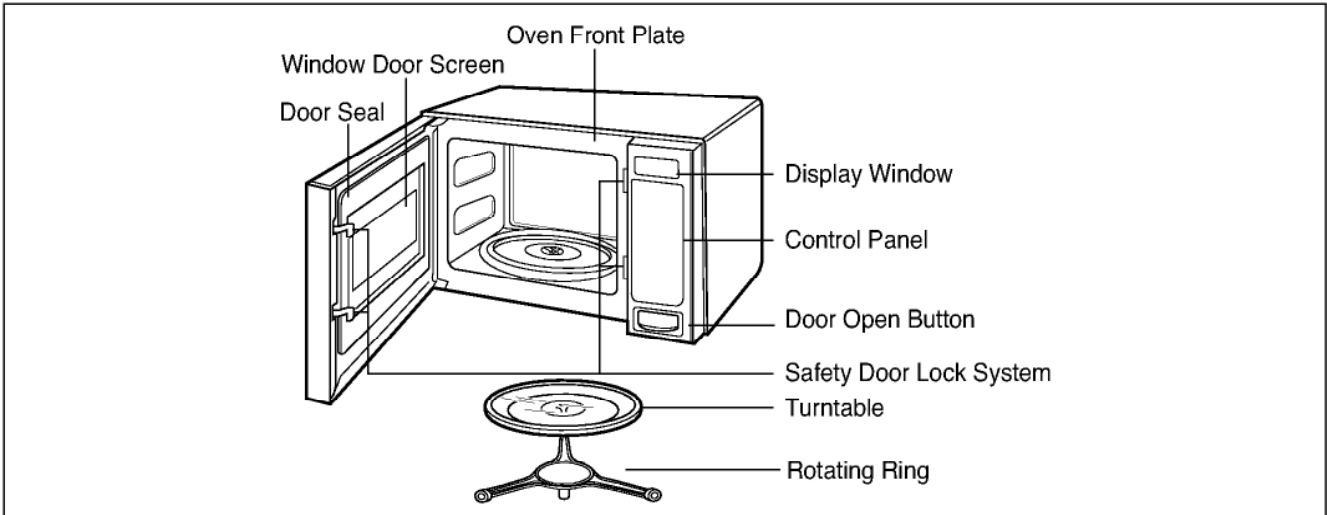

## CONTROL PANEL

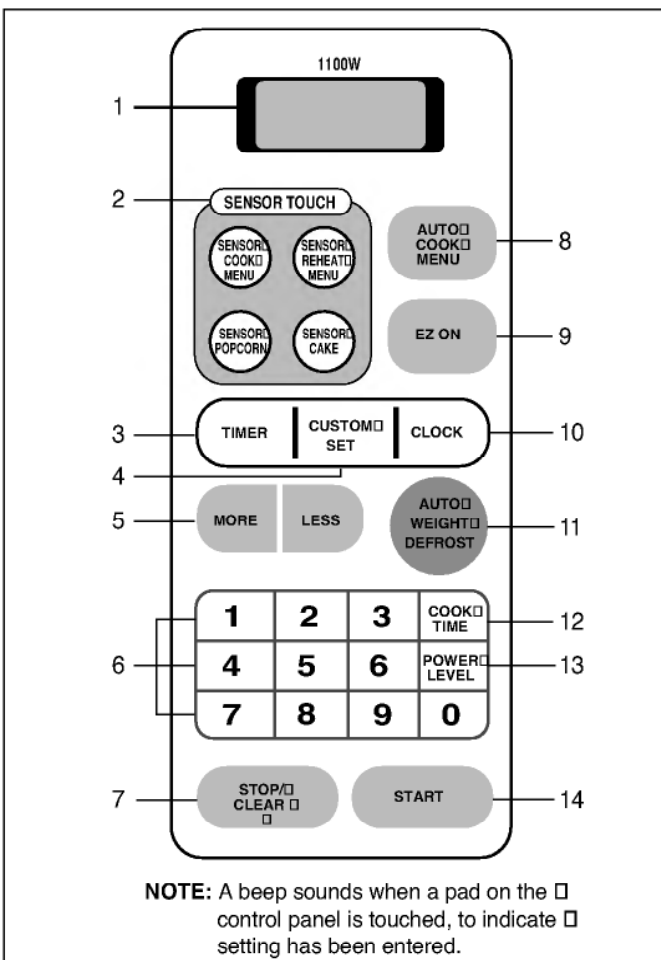

- 1. DISPLAY WINDOW.**
- 2. SENSOR TOUCH:** SENSOR COOK MENU / SENSOR REHEAT MENU / SENSOR POPCORN / SENSOR CAKE
- 3. TIMER.**
- 4. CUSTOM SET:** You can select sound on/off, clock on/off, scroll speed, lbs/kg choice, demo on/off mode.
- 5. MORE / LESS:** All of the one touch cook and TIMED COOK can be adjusted to cook food for a longer or shorter time.
  - MORE → Pressing MORE will add 10 seconds to the cooking time.
  - LESS → Pressing LESS will subtract 10 seconds of cooking time.
- 6. NUMBER:** These used to set for time of day, cooking time, power level, or defrost weight.
- 7. STOP/CLEAR:** It used to stop oven and clear all entries except time of day.
- 8. AUTO COOK MENU.**
- 9. EZ ON:** You can extend cooking time in multiples of 30 seconds by repeatedly touching this pad during cooking.
- 10. CLOCK:** It is used to set the time of day.
- 11. AUTO WEIGHT DEFROST:** This feature provides you with the best defrosting method for frozen foods.
- 12. COOK TIME:** You can set the desired cook time.
- 13. POWER LEVEL:** You can select the desired power level for cooking.
- 14. START:** This feature allows oven to begin functioning.

# OPERATING SEQUENCE

The following is a description of component functions during oven operation.

## 1. SETTING THE CLOCK

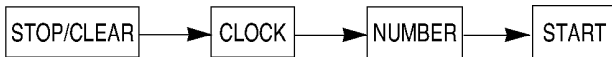

ex.) To set 4:30, touch number key [4],[3], and [0].

NOTE: 1) This is a 12 hour clock.

2) Clock will operate as long as power is applied to the oven.

## 2. CANCEL FUNCTION

Touch the [STOP/CLEAR] pad whenever you need to cancel an entry or a function currently in use.

The display will return either to the last item entered or to the clock.

## 3. EZ ON



## 4. AUTO COOKING

AUTO COOK has 6 foods categories

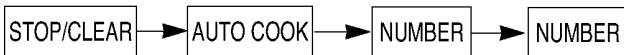

## 5. TIME COOKING

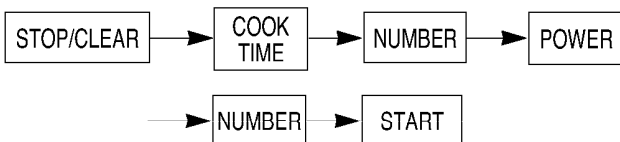

## 6. MULTI-STAGE COOKING

1ST STAGE

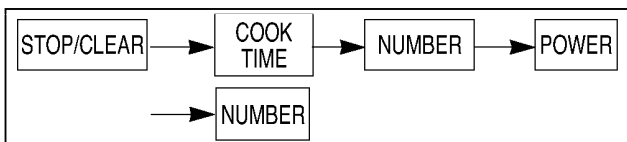

2ND STAGE

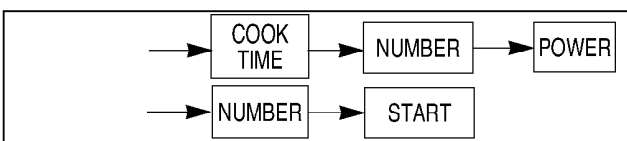

## 7. AUTO WEIGHT DEFROST COOKING

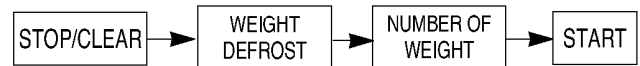

## 8. CHILD LOCK

This oven has a CHILD LOCK feature  
TO SET CHILD LOCK

- Touch the [STOP/CLEAR] pad
- Touch and hold [0] pad → **LOCKED** appears on the display.

TO CANCEL CHILD LOCK

- Touch and hold [0] pad → **LOCKED** disappears.

## 9. MORE / LESS

The cook time is adjustable by MORE pad or LESS pad.

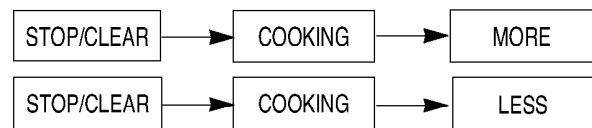

## 10. SENSOR COOK

Sensor cook has 10 foods categories.



## 11. CUSTOM SET

You can select Sound On/Off, Clock On/Off, Scroll Speed, Lbs/Kg Choice, Demo On/Off modes.

- To turn ON/OFF sound.



- To select scroll speed

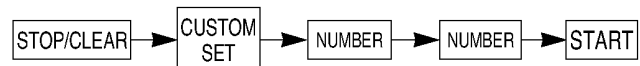



# SCHEMATIC DIAGRAM

4-3

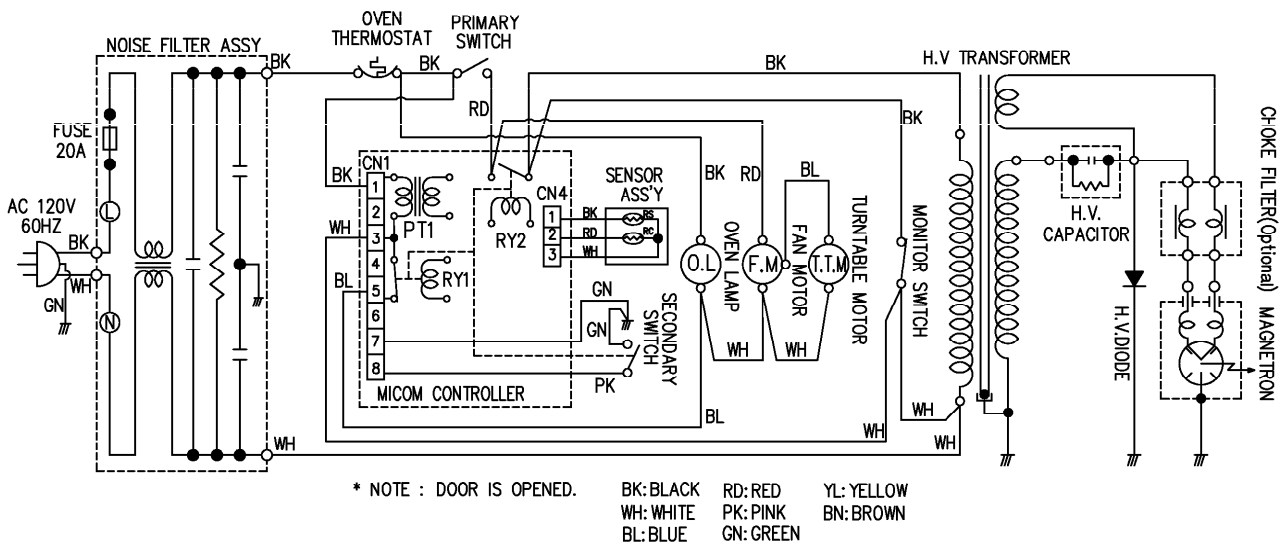

IMPORTANT SAFETY NOTE: THE SHADED AREAS ON THIS SCHEMATIC DIAGRAM INCORPORATE SPECIAL FEATURES IMPORTANT FOR PROTECTION FROM MICROWAVE RADIATION, FIRE, ELECTRICAL SHOCK, AND HAZARDS. WHEN SERVICING IT IS ESSENTIAL THAT ONLY MANUFACTURER'S SPECIFIED PARTS BE USED FOR THE CRITICAL COMPONENTS IN THE SHADED AREAS OF THE SCHEMATIC DIAGRAM.

NOTICE: SINCE THIS IS BASIC SCHEMATIC DIAGRAM, THE VALUES OF COMPONENTS AND SOME PARTIAL CONNECTIONS ARE SUBJECT TO CHANGE FOR IMPROVEMENT.

# CIRCUIT DESCRIPTION

## GENERAL DETAILS

- The low voltage transformer supplies the necessary voltage to the micom controller when power cord is plugged in.
- When the door is closed, the primary switch is ON, the secondary switch is ON, and the monitor switch opens (contact COM and NO).

## WHEN SELECTING COOKING POWER LEVEL AND TIME

- The micom controller memorizes the function you set.
- The time you set appears in the display window.
- Each indicator light turns on to indicate that the stage has been set.

## WHEN TOUCHING THE START PAD

- The coil of the relay is energized by the micom controller.
- Power input is supplied to the high voltage transformer through the fuse to the primary switch and relay 2.
- Turntable rotates.

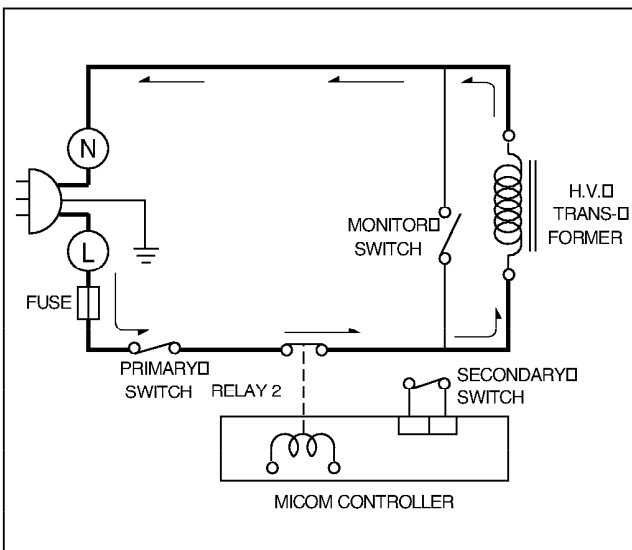

- The fan motor rotates and cools the magnetron by blowing the air (coming from the intake on the base-plate).
- The air is also directed into the oven to exhaust the vapor in the oven through the upper plate.
- Cooking time starts counting down.
- 3.3 volts AC is generated from the filament winding of the high voltage transformer. This 3.3 volts is applied to the magnetron to heat the magnetron filament through two noise-preventing choke coils.

- A high voltage of approximately 2100 volts AC is generated in the secondary of the high voltage transformer which is increased by the action of the high voltage diode and charging of the high voltage capacitor.
- The negative 4,000 Volts DC is applied to the filament of the magnetron.

## WHEN THE OVEN IS SET AT ANY LEVEL EXCEPT MAXIMUM.

- The micom controller controls the ON-OFF time of relay 2 by the applied signal to vary the average output power of microwave oven as POWER LEVEL. (refer to page 1-1)
- One complete cycle of relay 2 is 22 seconds.

## WHEN THE DOOR IS OPENED DURING COOKING

- Both the primary switch and relay 2 cut off the primary winding voltage of the high voltage transformer.
- ON-OFF of relay 2 is coupled electrically with opening and closing of the secondary switch.
- When the door is opened, the secondary switch is opened and when the door is closed, the secondary switch is closed.
- The cooking time stops counting down.
- Relay stops functioning.
- As the door is opened, if the contact of primary switch and relay2 and/or secondary switch fail to open, the fuse opens due to the large current surge caused by the monitor switch activation, which in turn stops magnetron oscillation.

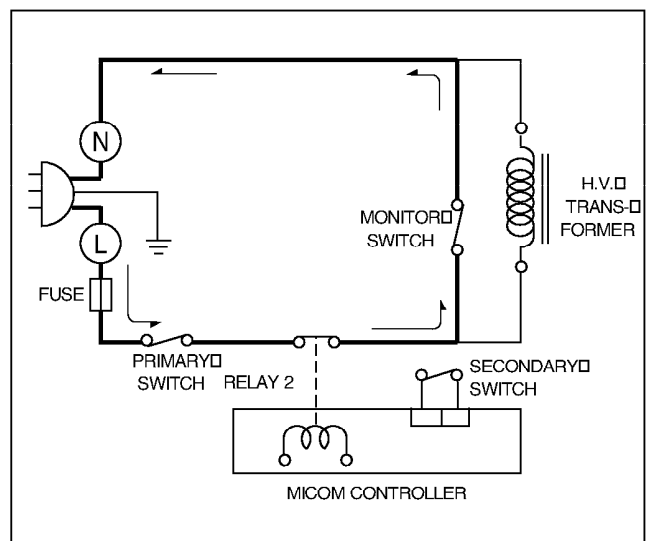

# SERVICE INFORMATION

## TOOLS AND MEASURING INSTRUMENTS

---

### NECESSARY TOOLS

Tools normally used for TV servicing are sufficient. Standard tools are listed below.

- Diagonal pliers
- Long nose pliers
- Phillips screwdriver
- Flat blade screwdriver
- Wrench (size 5mm)
- Nutdriver (size 5mm)
- Adjustable wrench
- Soldering iron
- Solder
- Vinyl insulation tape
- Polishing cloth

### NECESSARY MEASURING INSTRUMENTS

- TESTER (VOLTS-DC, AC, Ohmmeter)
- Microwave survey meter
  - Holaday HI-1500  
HI-1501
  - Narda 8100  
8200
- Inch scale
- 600 cc non conductive material beaker (glass or plastic),  
inside diameter: approx. 8.5 cm (3 1/2 in.)
- Cylindrical and made of borosilicate glass vessel.  
max. thickness: 3 mm  
outside diameter: approx. 190mm  
height: approx. 90mm
- Glass thermometer: 100°C or 212°F (1 deg scale)

## MICROWAVE LEAKAGE TEST

---

### CAUTIONS

- **Be sure to check microwave leakage prior to servicing the oven if the oven is operative prior to servicing.**
- **The service personnel should inform the manufacture importer, or assembler of any certified oven unit found to have a microwave emission level in excess of 5 mW/cm<sup>2</sup> and should repair any unit found to have excessive emission levels at no cost to the owner and should ascertain the cause of the excessive leakage. The service personnel should instruct the owner not to use the unit until the oven has been brought into compliance.**
- **If the oven operates with the door open, the service personnel should:**
  - **Tell the user not to operate the oven.**
  - **Contact the manufacturer.**
- The service personnel should check all surface and vent openings for microwave leakage.
- Check for microwave leakage after every servicing. The power density of the microwave radiation leakage emitted by the microwave oven should not exceed 4 mW/cm<sup>2</sup>. Always start measuring of an unknown field to assure safety for operating personnel from radiation leakage.

### MEASURING MICROWAVE ENERGY LEAKAGE

- **Pour 275±15cc of 20±5°C(68±9°F) water in a beaker which is graduated to 600 cc, and place the beaker on the center of the turntable.**
- **Set the energy leakage monitor to 2,450 MHz and use it following the manufacturer's recommended test procedure to assure correct result.**
- **When measuring the leakage, always use the 2-inch (5cm) spacer supplied with the probe.**
- **Operate the oven at its maximum output.**
- **Measure the microwave radiation using and electromagnetic radiation monitor by holding the probe perpendicular to the surface being measured**

Move probe along shaded area

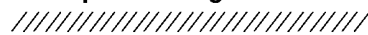

Probe scanning speed

Less than 2.5 cm/sec

( 1in/sec)

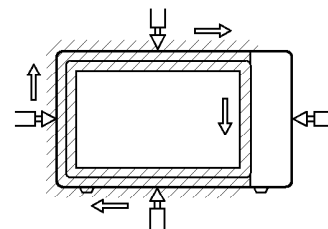

## MEASUREMENT WITH OUTER CASE REMOVED

- When you replace the magnetron, measure for microwave energy leakage before the outer case is installed and after all necessary components are replaced or adjusted.  
Special care should be taken in measuring the following parts. (Circled area of Fig. below)
  - Around the magnetron
  - The waveguide

**WARNING : AVOID CONTACTING ANY HIGH VOLTAGE PARTS**

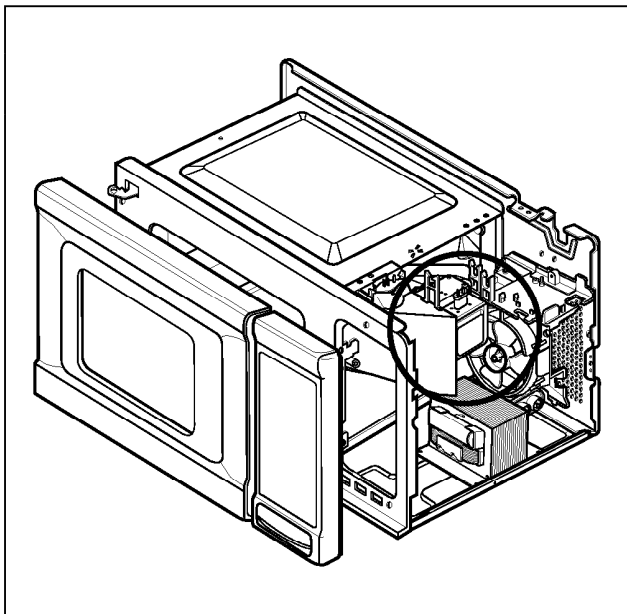

## MEASUREMENT WITH A FULLY ASSEMBLED OVEN

- After all components, including the outer case, are fully assembled, measure for microwave energy leakage around the door viewing window, the exhaust opening, and air inlet openings.
- Microwave energy leakage must not exceed the values prescribed below.

**NOTE:** Leakage with the outer case removed less than 5 mW/cm.sq. Leakage for a fully assembled oven (Before the latch switch (primary) is interrupted) with the door in a slightly opened position-less than 2 mW/cm.sq.

## NOTES WHEN MEASURING

- Do not exceed meter full scale deflection.
- The test probe must be removed no faster than 1 inch/sec (2.5 cm/sec) along the shaded area, otherwise a false reading may result.
- The test probe must be held with the grip portion of the handle.  
A false reading may result if the operator's hand is between the handle and the probe.
- When testing near a corner of the door, keep the probe perpendicular to the surface making sure the probe horizontally along the oven surface; this may possibly cause probe damage.

## RECORD KEEPING AND NOTIFICATION AFTER MEASUREMENT

- After adjustment and repair of any microwave energy interruption or microwave energy blocking device, record the measured values for future reference. Also enter the information on the service invoice.
- The microwave energy leakage should not be more than 4 mW/cm.sq. after determining that all parts are in good condition, functioning properly and genuine replacement parts which are listed in this manual have been used.
- At least once a year, have the electromagnetic energy leakage monitor checked for calibration by its manufacturer.

# MEASUREMENT OF MICROWAVE POWER OUTPUT

- Microwave power output measurement is made with the microwave oven supplied at its rated voltage and operated at its maximum microwave power setting with a load of (1000±5) g of potable water.
- The water is contained in a cylindrical borosilicate glass vessel having a maximum material thickness of 3 mm and an outside diameter of approximately 190mm.
- The oven and the empty vessel are at ambient temperature prior to the start of the test.
- The initial temperature (T1) of the water is (10±2)°C It is measured immediately before the water is added to the vessel. After addition of the water to the vessel, the load is immediately placed on the center of the turntable which is in the lowest position and the microwave power switched on.
- The time T for the temperature of the water to rise by a value Δ T of (10±2)°K is measured, where T is the time in seconds and ΔT is the temperature rise. The initial and final water temperatures are selected so that the maximum difference between the final water temperature and the ambient temperature is 5°K.

- The microwave power output P in watts is calculated from the following formula :

$$P = \frac{4187 \times (\Delta T)}{T}$$

is measured while the microwave generator is operating at full power. Magnetron filament heat-up time is not included. (about 3 sec)

- The water is stirred to equalize temperature throughout the vessel, prior to measuring the final water temperature.
- Stirring devices and measuring instruments are selected in order to minimize addition or removal of heat.

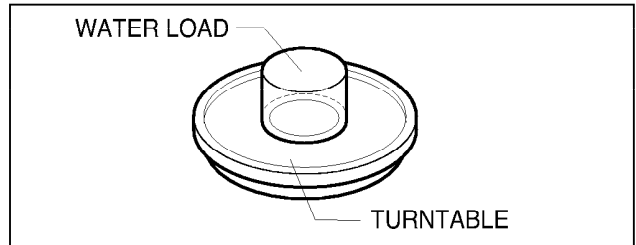

# DISASSEMBLY AND ADJUSTMENT

## A. OUTER CASE REMOVAL

- 1) Disconnect the power supply cord from the outlet.
- 2) Remove the screws from the rear of the case.  
The outer case must be moved backward to be lifted off.

## B. POWER SUPPLY CORD

- 1) Remove the outer case.
- 2) Disconnect two terminals, and remove one screw of the ground terminal.

## C. CONTROL PANEL ASSEMBLY

- 1) Open the door.
- 2) Disconnect the leadwire from RELAY (RY2) of the PCB SUB ASS'Y.
- 3) Disconnect the leadwire from connector (CN1) of the PCB SUB ASS'Y.
- 4) Lift up and pull out control panel assembly carefully from the cavity.

**CAUTION: DISCHARGE THE HIGH VOLTAGE CAPACITOR BEFORE SERVICING**  
(refer to page 2-1)

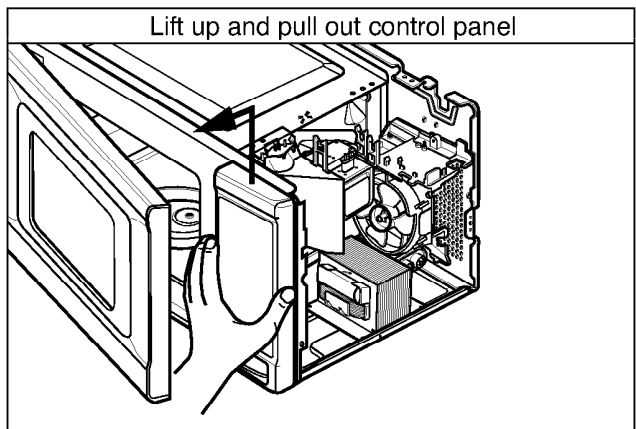
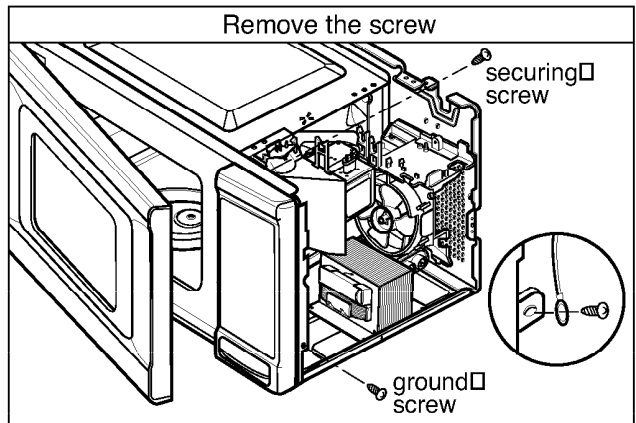

## D. PCB ASSEMBLY REMOVAL

- 1) Remove the control panel assembly from the cavity. (Refer to control panel assembly removal on previous page.)
- 2) Remove screws which hold the PCB SUB ASS'Y to the control panel.
- 3) Disconnect the flat cable from the PCB SUB ASS'Y and take off the PCB SUB ASS'Y

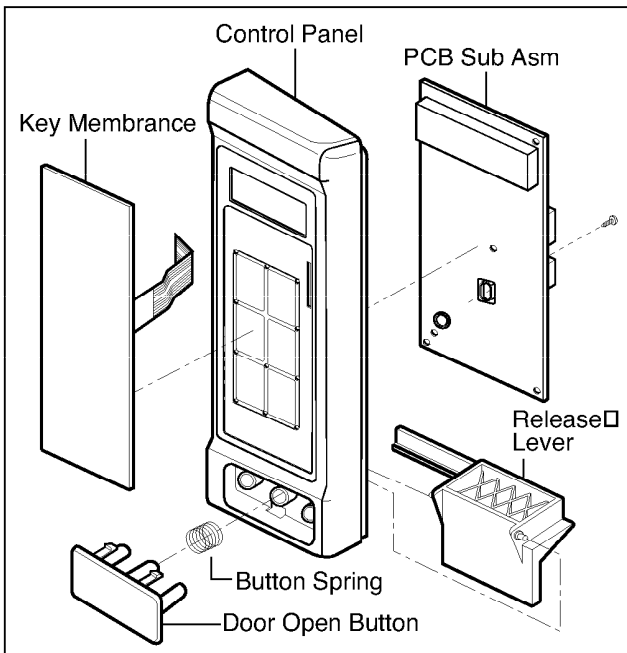

## E. DOOR MAIN ASSEMBLY REMOVAL

- 1) Open the door.
  - 2) Remove the choke cover very carefully with a flat-blade screwdriver.
- CAUTION: Be careful not to damage door seal plate by screwdriver.**
- 3) Lift up and push the door.

### NOTE:

1. After replacing the door, be sure to check that the primary switch, monitor switch, and secondary switch operate normally.
2. After replacing the door, check for microwave energy leakage with a survey meter. Microwave energy must be below the limit of 4 mW/cm. (with a 275 ml water load)
3. When mounting the door assembly to the oven assembly, be sure to adjust the door assembly parallel to the chassis. Also adjust so the door has no play between the inner door surface and oven frame assembly. If the door assembly is not mounted properly, microwaves may leak from the clearance between the door and the oven.

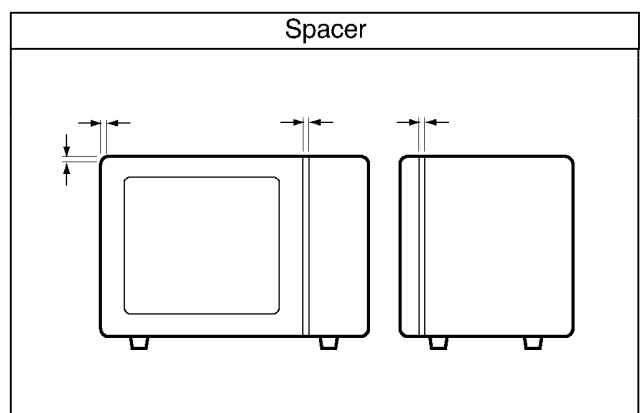
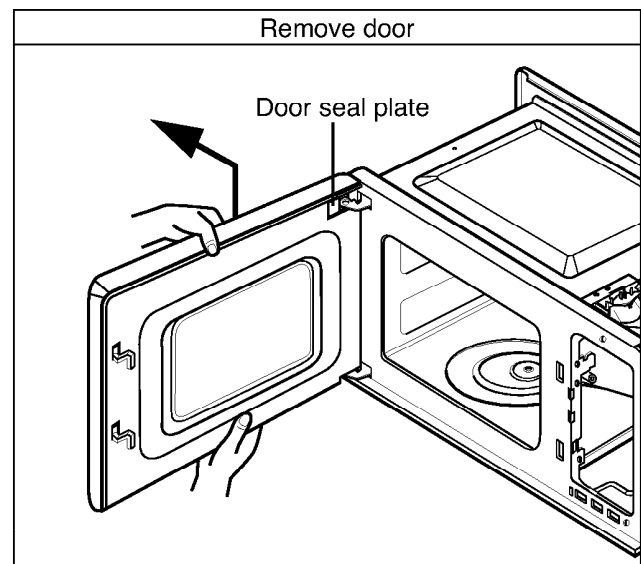
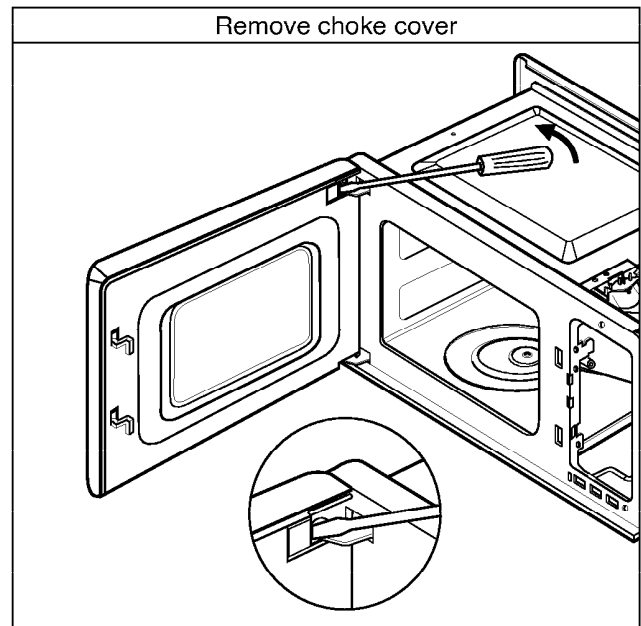

## F. MAGNETRON REMOVAL

- 1) Disconnect the leadwire from the magnetron.
- 2) Carefully remove the mounting screws holding the magnetron and the waveguide.
- 3) Remove the magnetron ASS'Y until the tube is clear from the waveguide.

### NOTE:

1. When removing the magnetron, make sure its dome does not hit any adjacent parts, or it may be damaged.
2. When replacing the magnetron, be sure to install the magnetron gasket in the correct position and be sure that the gasket is in good condition.
3. After replacing the magnetron, check for microwave leakage with a survey meter around the magnetron. Microwave energy must be below the limit of  $5 \text{ mW/cm}^2$ . (With a 275 ml. water load).

**Make sure that gasket is rigidly attached to the magnetron.** To prevent microwave leakage, tighten the mounting screws properly, making sure there is no gap between the waveguide and the magnetron.

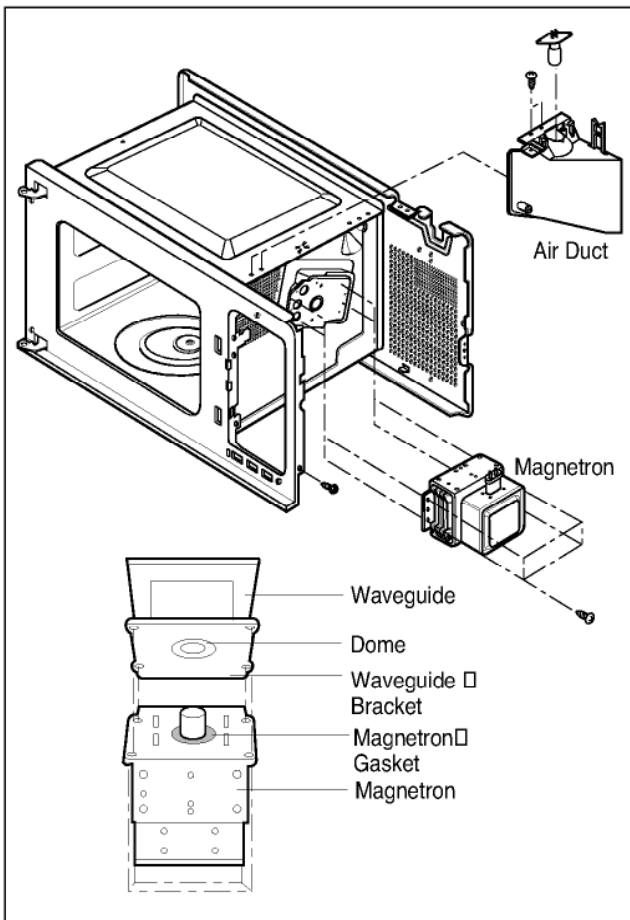

## G. REMOVING THE TURNTABLE MOTOR

- 1) Remove the turntable and rotating ring.
- 2) Lay the unit down on its back.
- 3) Remove the turntable motor cover. The turntable base cover is easily removed by pinching the eight parts with a wire cutting.
- 4) Disconnect the leadwire from the turntable motor terminals.
- 5) Remove the screw securing the turntable motor to the oven cavity ASS'Y
- 6) After repairing the motor, rotate the removed turntable motor cover.
- 7) Fit the turntable motor cover's projecting part to the base plate slit.

### NOTE:

1. Remove the wire lead from the turntable motor VERY CAREFULLY.
2. Be sure to grasp the connector, not the wires, when removing.

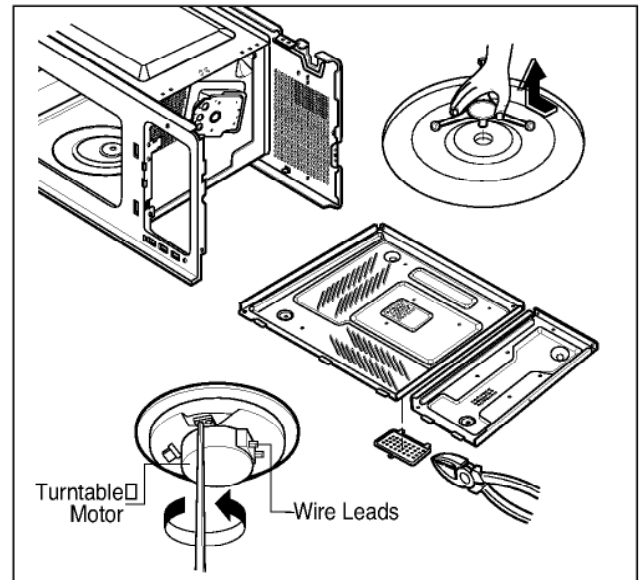

## H. REMOVING SENSOR

- 1) Disconnect the leadwire from PCB Assembly.
- 2) Remove a screw securing the sensor duct.

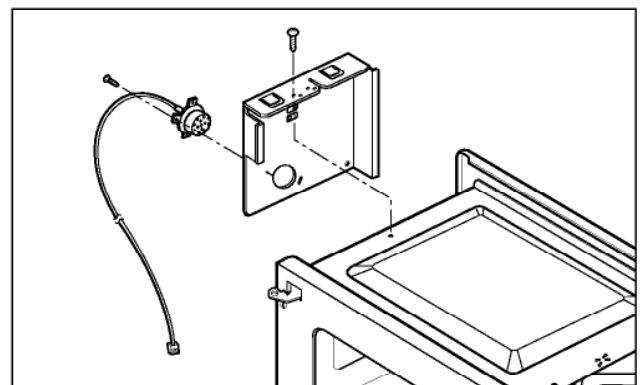

## I. HIGH VOLTAGE TRANSFORMER REMOVAL

- 1) Discharge the high voltage capacitor.
- 2) Disconnect the leadwire from magnetron, high voltage transformer, and capacitor.
- 3) Remove the screw holding the high voltage transformer to the baseplate.

## J. FAN MOTOR ASSEMBLY REMOVAL

- 1) Discharge the high voltage capacitor.
- 2) Disconnect the leadwire from fan motor, noise filter and high voltage capacitor.
- 3) Remove the two screws holding the the suction guide ASS'Y to the oven cavity and remove the high voltage diode earth screw.
- 4) Remove the two screws holding the fan motor ASS'Y to the suction guide ASS'Y.

## K. HIGH VOLTAGE CAPACITOR AND DIODE REMOVAL

- 1) Discharge the high voltage capacitor.
- 2) Disconnect the leadwire from fan motor, noise filter and high voltage capacitor.
- 3) Remove the screw holding the suction guide ASS'Y to the oven cavity and remove the high voltage diode earth screw.
- 4) Remove the screw holding the high voltage capacitor bracket.

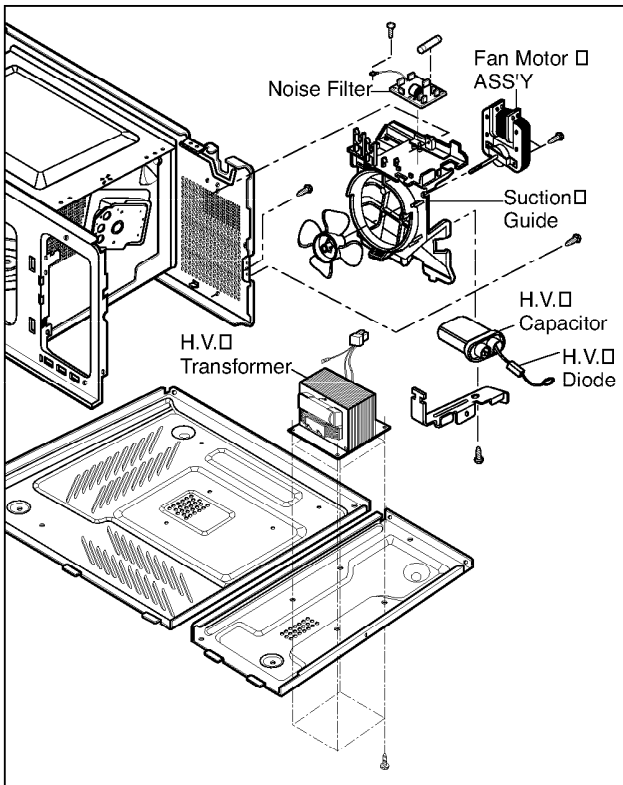

## L. INTERLOCK SYSTEM

### 1) INTERLOCK MECHANISM

The door lock mechanism is a device which has been specially designed to eliminate completely microwave activity when the door is opened during cooking and thus to prevent the danger resulting from the microwave leakage.

### 2) MOUNTING OF THE PRIMARY/MONITOR/SECONDARY SWITCHES TO THE LATCH BOARD

### 3) INSTALLATION AND ADJUSTMENT OF THE LATCH BOARD TO THE OVEN ASSEMBLY

- Mount the latch board to the oven assembly.
- Adjust the latch board in the arrow direction so that oven door will not have any play in it when the door is closed.
- Tighten the mounting screw.
- **Check for play in the door by pushing the door release button. Door movement should be less than 0.5 mm. (1/64 inch)**

Don't push the door release button while making this adjustment. Make sure that the latch moves smoothly after adjustment is completed and that the screws are tight. Make sure the primary, monitor, and secondary switches operate properly by following the continuity test procedure.

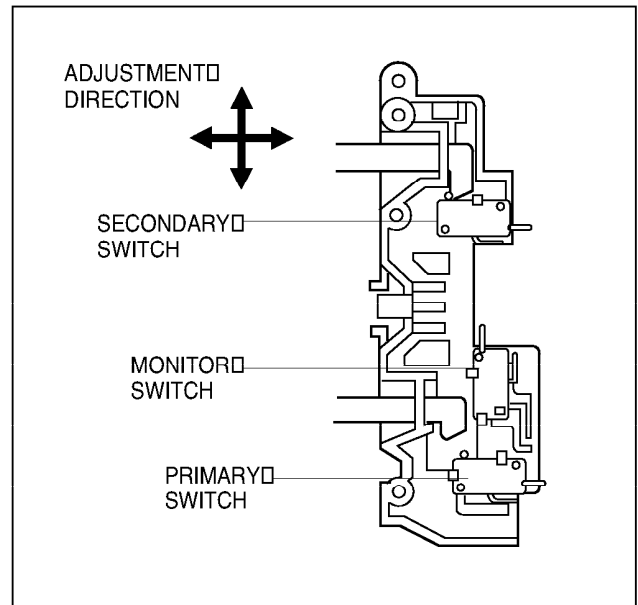



# INTERLOCK CONTINUITY TEST

**WARNING : FOR CONTINUED PROTECTION AGAINST EXCESSIVE RADIATION EMISSION, REPLACE ONLY WITH IDENTICAL REPLACEMENT PARTS.**

TYPE NO. SZM-V 16-FA-63 OR VP-533A-OF FOR PRIMARY SWITCH  
 TYPE NO. SZM-V 16-FA-62 OR VP-532A-OF FOR MONITOR SWITCH  
 TYPE NO. SZM-V 16-FA-63 OR VP-533A-OF FOR SECONDARY SWITCH

## A. PRIMARY INTERLOCK SWITCH TEST

When the door release button is depressed slowly with the door closed, an audible **click** should be heard at the same time or successively at intervals. When the button is released slowly, the latches should activate the switches with an audible **click**.

If the latches do not activate the switches when the door is closed, the switches should be adjusted in accordance with the adjustment procedure. Disconnect the wire lead from the primary switch. Connect the ohmmeter leads to the common (COM) and normally open (NO) terminal of the switch. The meter should indicate an open circuit in the door open condition. When the door is closed, the meter should indicate a closed circuit.

When the primary switch operation is abnormal, make the necessary adjustment or replace the switch only with the same type of switch.

## B. SECONDARY INTERLOCK SWITCH TEST







Disconnect the wire lead from the secondary switch.

Connect the ohmmeter leads to the common (COM) and normally open (NO) terminals of the switch. The meter should indicate a open circuit in the door open condition. When the door is closed, meter should indicate an closed circuit. When the secondary switch operation is abnormal, make the necessary adjustment or replace the switch only with the same type of switch.

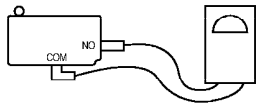
## C. MONITOR SWITCH TEST

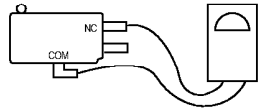
Disconnect the wire lead from the monitor switch. Connect the ohmmeter leads to the common (COM) and normally closed (NC) terminals of the switch. The meter should indicate closed circuit in the door open condition. When the door is closed, meter should indicate an open circuit. When the monitor switch operation is abnormal, replace with the same type of switch.

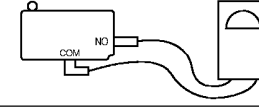
**NOTE: After repairing the door or the interlock system, it is necessary to do this continuity test before operating the oven.**

COMPONENTS	TEST PROCEDURE	RESULTS	
		Door open	Door closed
SWITCHES (Wire leads removed)	Check for continuity of the switch with an Ohm-meter		
	Primary Switch 		
	Monitor Switch 		
	Secondary Switch 		
NOTE : After checking for the continuity of switches, make sure that they are connected correctly.			



# COMPONENT TEST PROCEDURE

## CAUTIONS

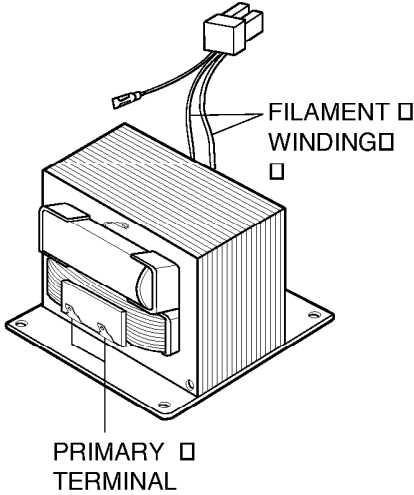
1. DISCONNECT THE POWER SUPPLY CORD FROM THE OUTLET WHENEVER REMOVING THE OUTER CASE FROM THE UNIT. PROCEED WITH THE TEST ONLY AFTER DISCHARGING THE HIGH VOLTAGE CAPACITOR AND REMOVING THE WIRE LEADS FROM THE PRIMARY WINDING OF THE HIGH VOLTAGE TRANSFORMER. (SEE PAGE 2-1)
2. ALL OPERATIONAL CHECKS WITH MICROWAVE ENERGY MUST BE DONE WITH A LOAD (1 LITER OF WATER IN CONTAINER) IN THE OVEN.

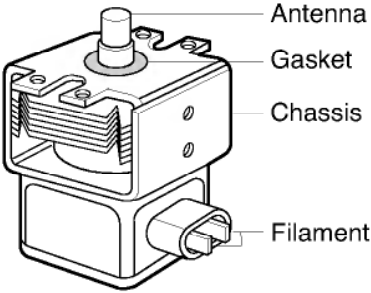
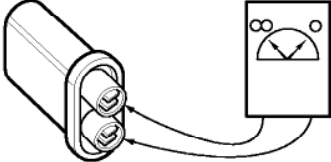
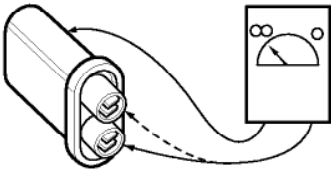
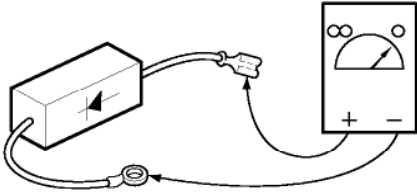
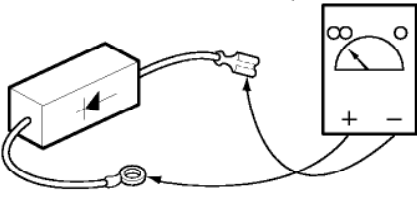
COMPONENTS	TEST PROCEDURE	RESULTS
<p>HIGH VOLTAGE TRANSFORMER (Wire leads removed)</p>	 <p>The diagram shows a high voltage transformer with a filament winding on top and a primary terminal on the bottom. A cable with a connector is attached to the filament winding.</p> <ol style="list-style-type: none"> <li>1. Measure the resistance. (Ohm-meter scale: Rx1 and Rx100) <ul style="list-style-type: none"> <li>• Primary winding</li> <li>• Secondary winding</li> <li>• Filament winding</li> </ul> </li> <li>2. Measure the resistance. (Ohm-meter scale: Rx1000) <ul style="list-style-type: none"> <li>• Primary winding to ground</li> <li>• Filament winding to ground</li> </ul> </li> </ol>	<p>Approx.: 0.2 ~ 0.4 ohm Approx.: 60 ~ 90 ohm Less than: 1 ohm</p> <p>Normal: Infinite Normal: Infinite</p>
<p>MAGNETRON (Wire leads removed)</p>	<ol style="list-style-type: none"> <li>1. Measure the resistance. (Ohm-meter scale: Rx1) <ul style="list-style-type: none"> <li>• Filament terminal</li> </ul> </li> <li>2. Measure the resistance. (Ohm-meter scale: Rx1000) <ul style="list-style-type: none"> <li>• Filament to chassis</li> </ul> </li> </ol>	<p>Normal: Less than 1 ohm</p> <p>Normal: Infinite</p>

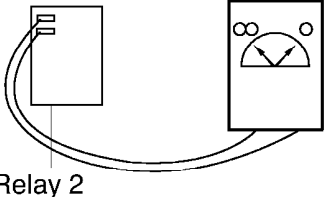
COMPONENTS	TEST PROCEDURE	RESULTS
	 <p>NOTE: When testing the magnetron, be sure to install the magnetron gasket in the correct position and be sure that the gasket is in good condition.</p>	
HIGH VOLTAGE CAPACITOR	<p>Measure the resistance. (Ohm-meter scale: Rx1000) • Terminal to terminal.</p> 	Normal: Momentarily indicates several ohms, and then gradually returns to infinite.
	<p>Measure the resistance. (Ohm-meter scale: Rx1000) • Terminal to case.</p> 	Normal: Infinite.
HIGH VOLTAGE DIODE	<p>Measure the continuity (Forward). (Ohm-meter scale: Rx10000)</p> 	Normal: Continuity. Abnormal: Infinite.
NOTE : Some inexpensive meters may indicate infinite resistance in both direction.	<p>Measure the continuity (Reverse). (Ohm-meter scale: Rx10000)</p> 	Normal: Infinite. Abnormal: Continuity.

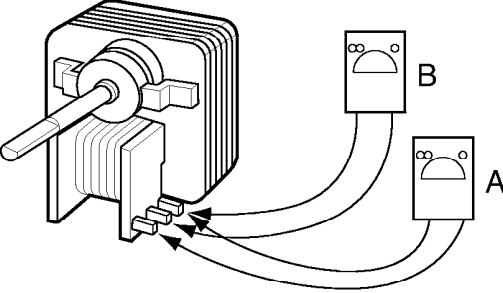
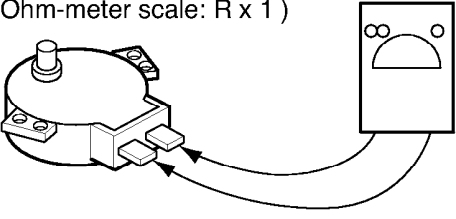
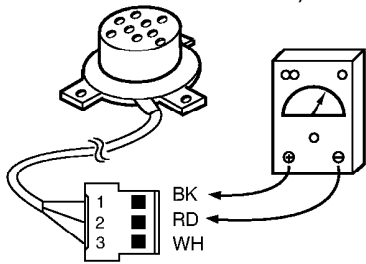
COMPONENTS	TEST PROCEDURE	RESULTS		
RELAY 2	Check for continuity of relay 2 with an ohm-meter. (Remove wire leads from relay 2 and operate the unit.)  	POWER LEVEL		
FAN MOTOR (Wire leads removed)	Measure the resistance. (Ohm-meter scale: R x 1)  	Normal: A: Approx. 85 ~ 100 ohm. B: Approx. 10 ~ 25 ohm.  Abnormal: Infinite or several ohm.		
TURNTABLE MOTOR (Wire leads removed)	Measure the resistance. (Ohm-meter scale: R x 1)  	Normal: Approx. 100~150 ohm Abnormal: Infinite or several ohm.		
SENSOR	1) Disconnect sensor connector from micom computer board. 2) Measure resistance terminal to terminal (ohm meter scale: R X 1000)  	Normal: Approximately BK - RD: 6.2 Kohm RD - WH: 3.1 Kohm BK - WH: 3.1 Kohm  Abnormal: Infinite or several.  * Sensor cooking condition 1. Oven should be plugged in at least 5 minutes before sensor cooking. 2. Room temperature should not exceed 95°F . 3. Be sure the exterior of the cooking container and the interior of the oven are dry. Wipe each off with paper towel. 4. The oven will not generate microwave energy for the first 28 seconds of the sensor cooking cycle.		
NOTE : • A MICROWAVE LEAKAGE TEST MUST ALWAYS BE PERFORMED WHEN THE UNIT IS SERVICED FOR ANY REASON. • MAKE SURE THE WIRE LEADS ARE IN THE CORRECT POSITION. • WHEN REMOVING THE WIRE LEADS FROM THE PARTS, BE SURE TO GRASP THE CONNECTOR, NOT THE WIRES.				

# TROUBLE SHOOTING

WHEN YOU GET A COMPLAINT FROM YOUR CUSTOMER, EVALUATE THE COMPLAINT CAREFULLY. IF THE FOLLOWING SYMPTOMS APPLY, PLEASE INSTRUCT THE CUSTOMER IN THE PROPER USE OF THE MICROWAVE OVEN. THIS CAN ELIMINATE AN UNNECESSARY SERVICE CALL.

## CAUTIONS

1. Check grounding before checking for trouble.
2. Be careful of the high voltage circuit.
3. Discharge the high voltage capacitor. (See page 2-1)
4. When checking the continuity of the switches or of the high voltage transformer, disconnect one lead wire from these parts and then check continuity with the AC plug removed. To do otherwise may result in a false reading or damage to your meter.
5. Do not touch any part of the circuit on the PCB since static electric discharge may damage this control panel.  
Always touch yourself to ground while working on this panel to discharge any static charge built up in your body. (Micom model only)

CONDITION	CAUSE	REMEDY
Microwave oven does not work.	Inserting many plugs into one outlet and using them at the same time. (blown fuse or breaker)	Avoid using other electrical appliances when you use the microwave oven.
	Microwave oven plug is not inserted tightly.	Insert microwave oven plug securely.
Output power is too low.	Low AC input voltage.	Use the microwave oven at adequate line voltage.
	Food temperature is too low.	This may not be a defect. It is possible that the food should be cooked for a longer time period.
Sparks occur.	Using metallic ware and allowing it to touch the oven wall.	Do not use metallic ware for cooking except that noted in the cooking guide.
	Ceramic ware trimmed in gold or silver powder is used.	Do not use any type of cookware with metallic trimming.
Uneven cooking.	Inconsistent intensity of microwave by their characteristics.	<ol style="list-style-type: none"> <li>1. Use plastic wrap or lid.</li> <li>2. Stir once or twice while cooking soup, cocoa or milk, etc.</li> </ol>

**(TROUBLE 1) The following visual conditions indicate a probable defective control circuit.**

1. Incomplete segments.
  - Segment missing.
  - Partial segment missing.
  - Digit flickering (NOTE: Slight flickering is normal.)
2. Colon does not turn on or blink.
3. A distinct change in the brightness of one or more numbers in display.
4. One or more digits in the display are not lighting.
5. Display indicates a number different from one touched, for example, key in **5** and **3** appears in the display.
6. Specific numbers (for example 7 or 9) will not display when key pad is touched.
7. Display does not count down with time blinking or up with clock operation.
8. Display obviously jumps in time while counting down.
9. Display counts down too fast while cooking.
10. Each indicator light does not turn on after setting cooking cycle.
11. Display time of day does not reappear when cooking is finished.

CONDITION	CHECK	RESULT	CAUSE	REMEDY
1. No input can be programmed.	Check the connection between membrane key assembly and PCB assembly.	Continuity	Defective PCB assembly.	Replace PCB assembly.
		No continuity	Loose connection.	Connect them tightly.
2. Some inputs cannot be programmed.	Replace key membrane assembly and check operation.	Everything works as specified.	Defective key membrane assembly.	Replace key membrane assembly.
3. Display shows a number or figure different from one touched.		Still have trouble.	Defective PCB assembly.	Replace PCB assembly.
4. Random programming when touching other pads.				
5. Display is fixed at some figure and can not accept any input.				

**(TROUBLE 2) Oven does not operate at all, Display window does not display any figures, and no input is accepted.**

CONDITION	CHECK	RESULT	CAUSE	REMEDY		
1. Fuse blows.	Check continuity of monitor switch (with door closed).	Continuity.	Malfunction of the monitor switch.	Replace fuse, primary, monitor, secondary switches, and RELAY(RY2) of P.C.B Assembly.		
		No continuity.				
	Replace fuse					
	Check continuity of primary switch (with door opened).	Continuity.	Shorted contact at the primary switch.		Replace fuse, primary, monitor, secondary switches, and RELAY(RY2) of P.C.B Assembly.	
		No continuity.				
	Check continuity of secondary switch (with door opened).	Continuity.	Malfunction of secondary switch.			Replace fuse, primary, monitor, secondary switches, and RELAY(RY2) of P.C.B Assembly.
		No continuity.				
	Disconnect one side of the wire lead connected from transformer to the high voltage capacitor and operate the unit.	Normal.	Defective high voltage capacitor.			
Fuse blows again		Defective high voltage transformer.	Replace high voltage transformer.			

**NOTE : All these switches must be replaced at the same time. Refer to page 5-7, 5-8**

2. Fuse does not blow.	Check continuity of thermostat.	No continuity.	Defective thermostat.	Replace thermostat.
		Continuity.		
	Check continuity of power supply cord.	No continuity.	Defective power supply cord.	Replace power supply cord.

**(TROUBLE 3) Display shows all figures set, but oven does not start cooking while desired program times are set and START pad is touched.**

CONDITION	CHECK	RESULT	CAUSE	REMEDY
1. Setting time does not count down when touching START pad.	Check continuity of secondary switch (with door closed).	No continuity.	Defective secondary switch.	Replace secondary switch.
		Continuity.		
	Check the connection between CN1 connector and PCB assembly.	Continuity	Defective PCB assembly.	Replace PCB assembly.
		No continuity	Loose connection.	Connect them tightly.
2. Fan motor or oven lamp do not turn on.	Check fan motor.	Abnormal	Defective fan motor.	Replace fan motor.
	Check oven lamp.	Abnormal	Defective oven lamp.	Replace oven lamp.
		Normal		

**(TROUBLE 4) Oven seems to be operating but little heat is produced in oven load.**

CONDITION	CHECK	RESULT	CAUSE	REMEDY
Output is low	Check the power source voltage.	Lower than 90% of rating voltage.	Decrease in power source voltage with load.	Suggest customer contact local electric power utility co. or qualified electrician.
		Normal		
	Disconnect the wire leads from relay 2 and check on and off time with multimeter.	Abnormal	Defective PCB assembly.	Replace PCB assembly.
	Normal			
	Measure the output power.	Abnormal	Defective magnetron.	Replace magnetron.

**NOTE :** Simple test of power output-conducted by heating one liter water for one min. if available. Minimum 8.5°C temperature rise is normal condition.



**(TROUBLE 5) No microwave oscillation even though oven lamp and fan motor run.  
(Display operates properly)**

CONDITION	CHECK	RESULT	CAUSE	REMEDY
No microwave oscillation.	Disconnect the wire leads from relay 2 and check continuity of relay 2. (Operate the unit)	No continuity.	Defective PCB assembly.	Replace PCB assembly.
		Continuity.		
	Check high voltage transformer	Abnormal	Defective high voltage transformer.	Replace high voltage transformer.
		Normal		
	Check high voltage capacitor.	Abnormal	Defective high voltage capacitor.	Replace high voltage capacitor.
		Normal		
	Check high voltage diode.	Abnormal	Defective high voltage diode.	Replace high voltage diode.
		Normal		
	Check magnetron.	Abnormal	Defective magnetron.	Replace magnetron.
		Normal		

**NOTE :** • Make sure the wire leads correct position.

- When Removing the wire leads from the parts, be sure to grasp the connector, not the wires.
- When removing the magnetron, be sure to install the magnetron gasket in the correct position and in good condition.

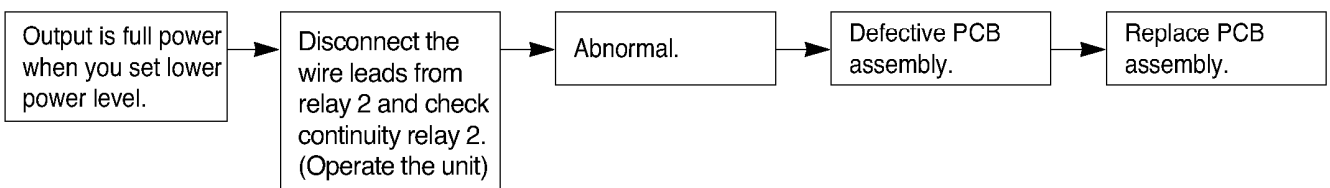

# EXPLODED VIEW

## INTRODUCTION

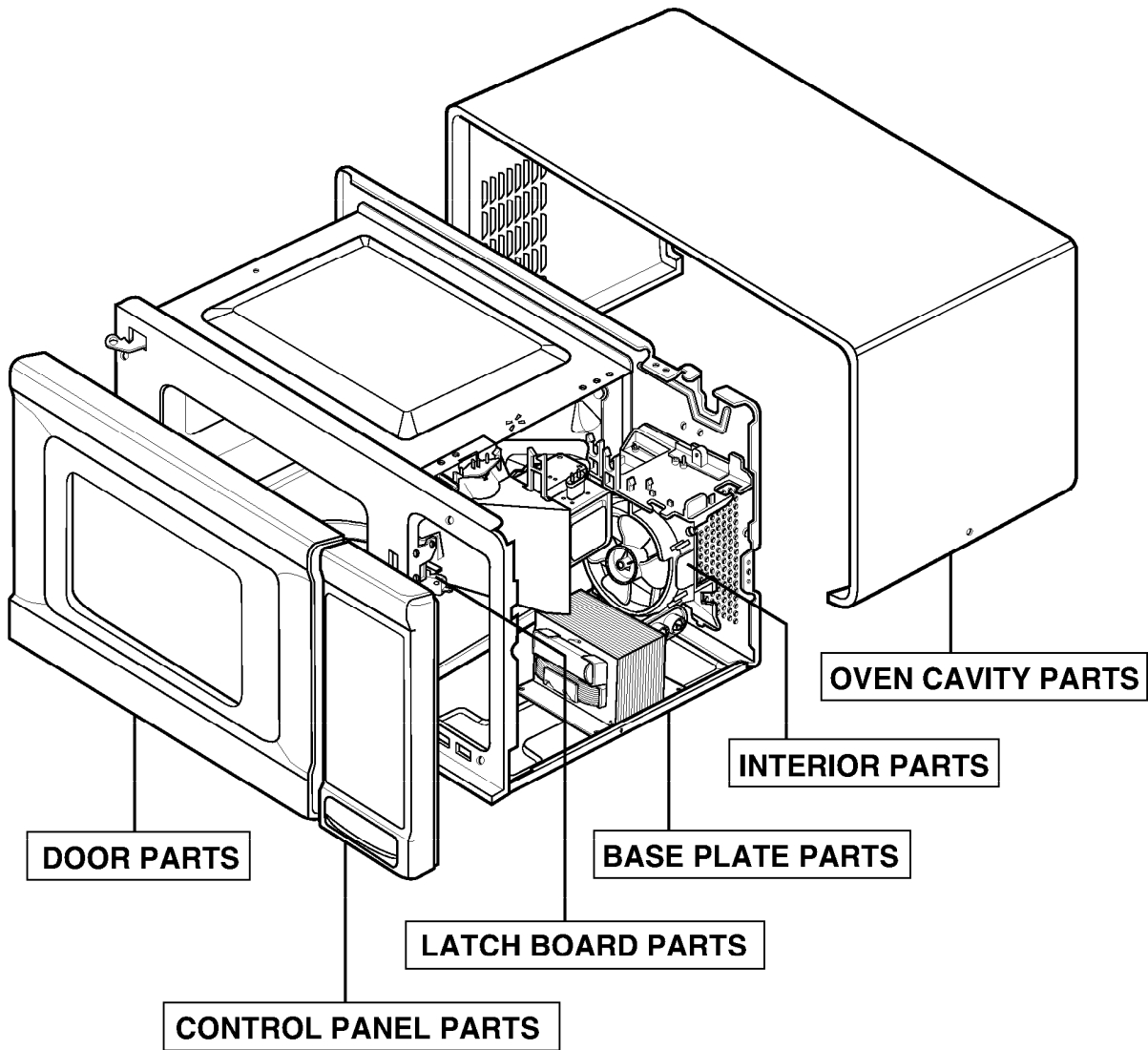

# DOOR PARTS

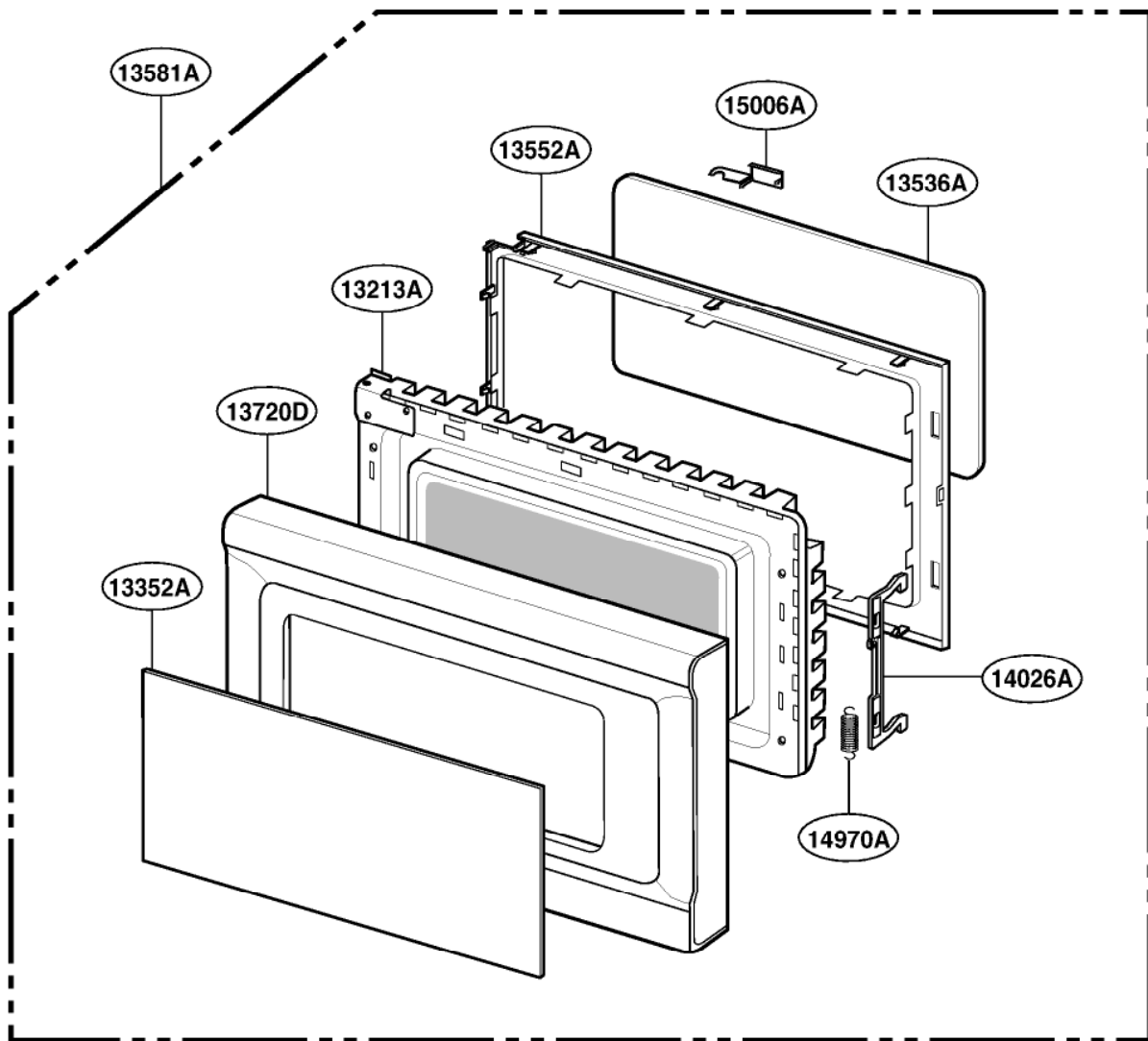

# CONTROLLER PARTS

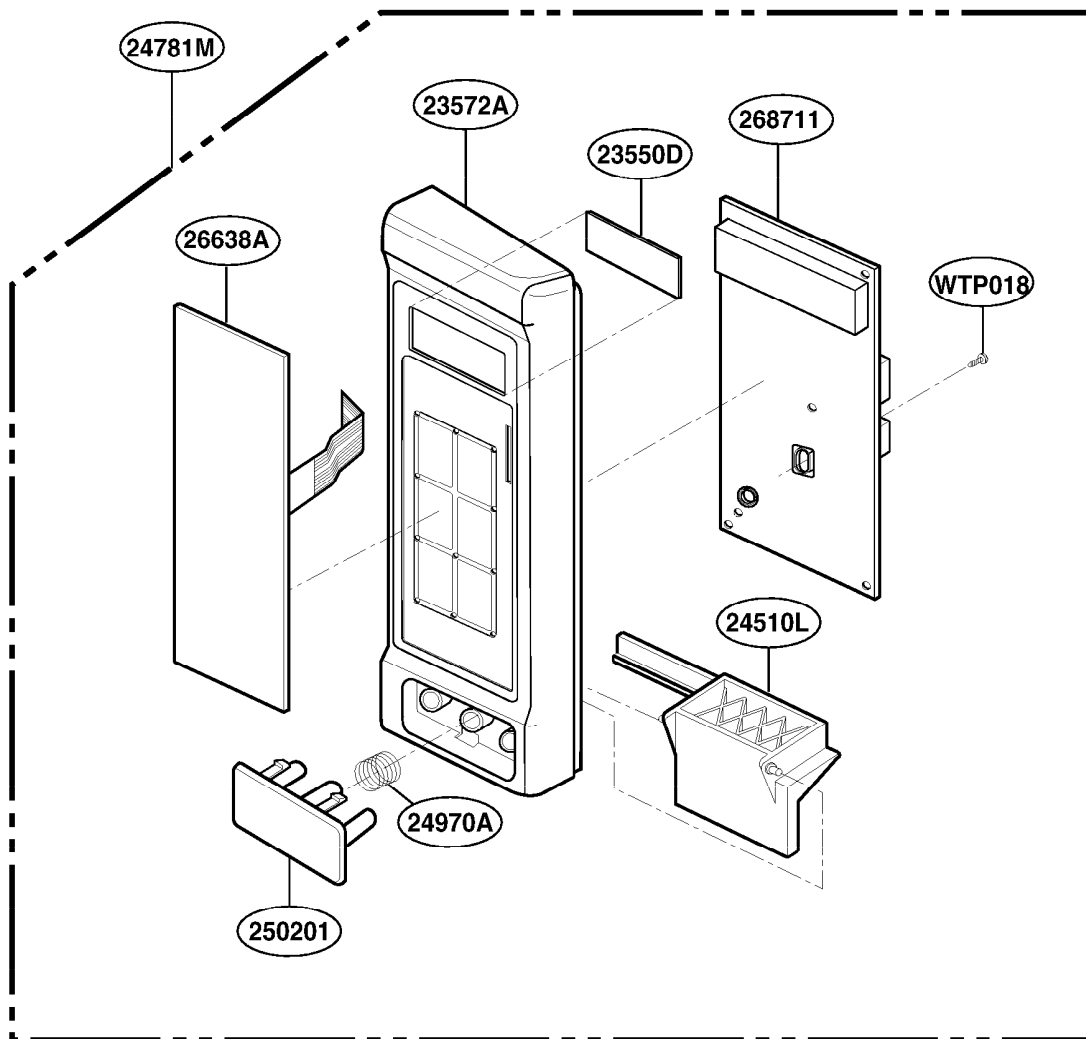

# OVEN CAVITY PARTS

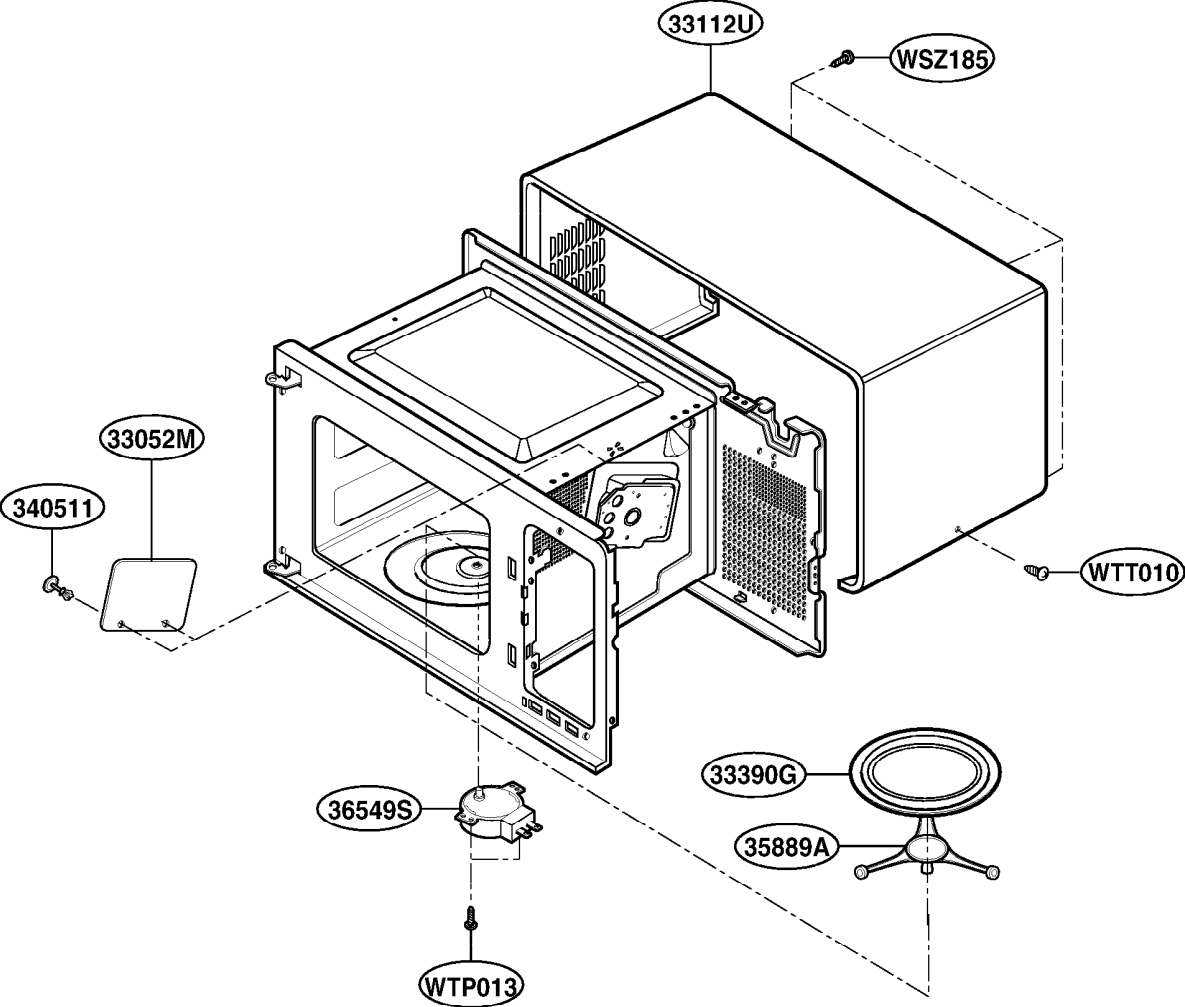

# LATCH BOARD PARTS

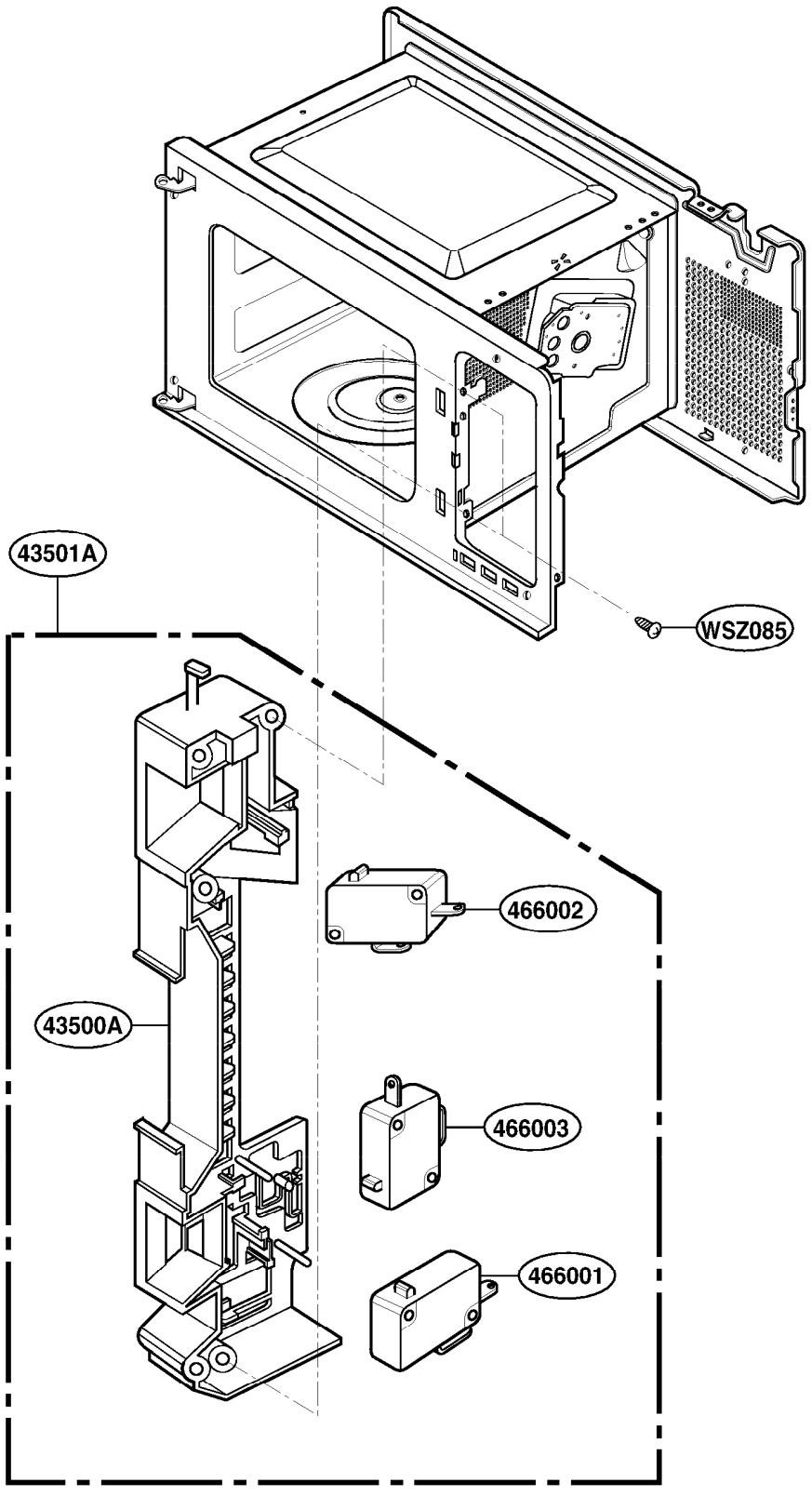

# INTERIOR PARTS

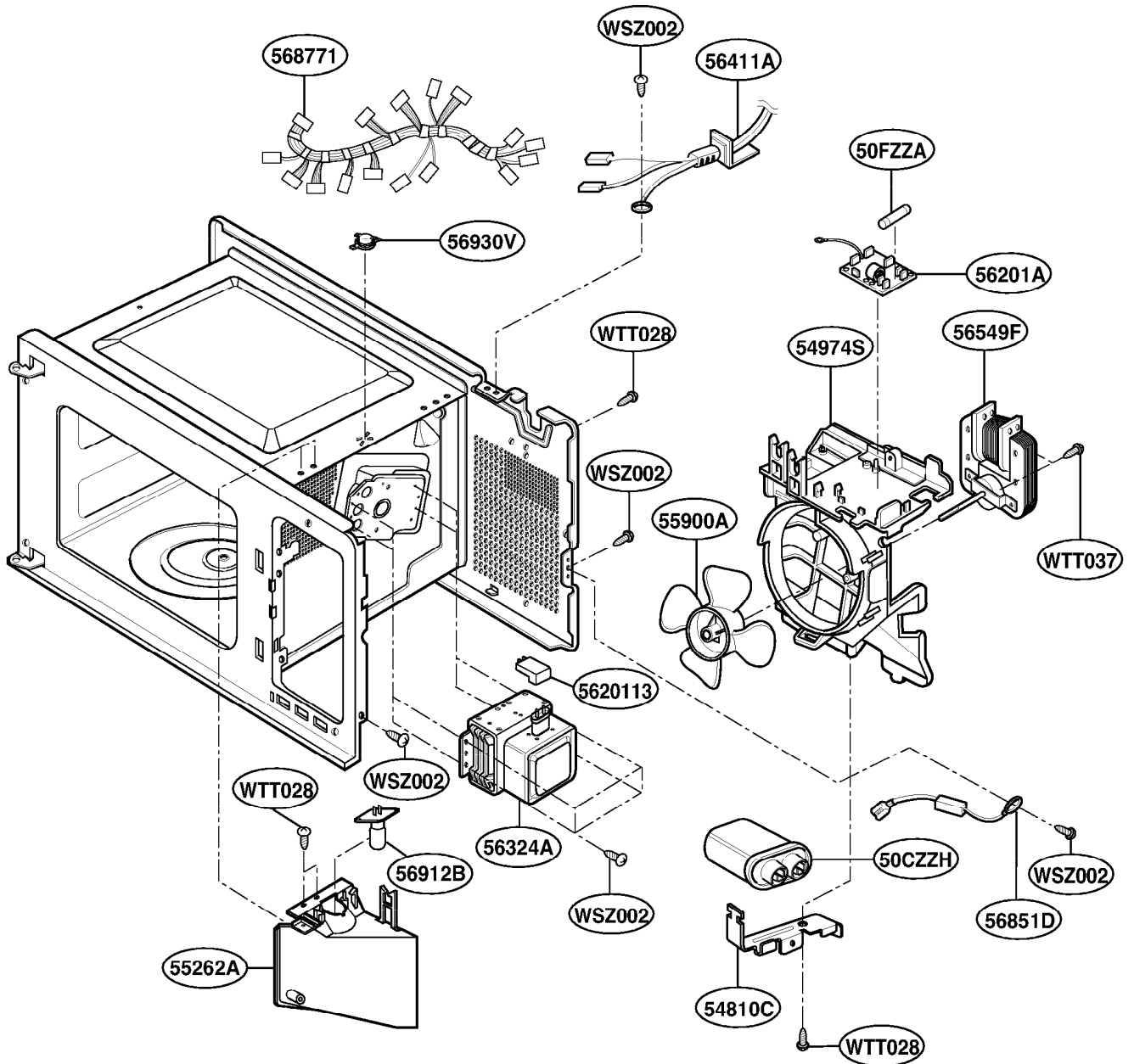

# BASE PLATE PARTS

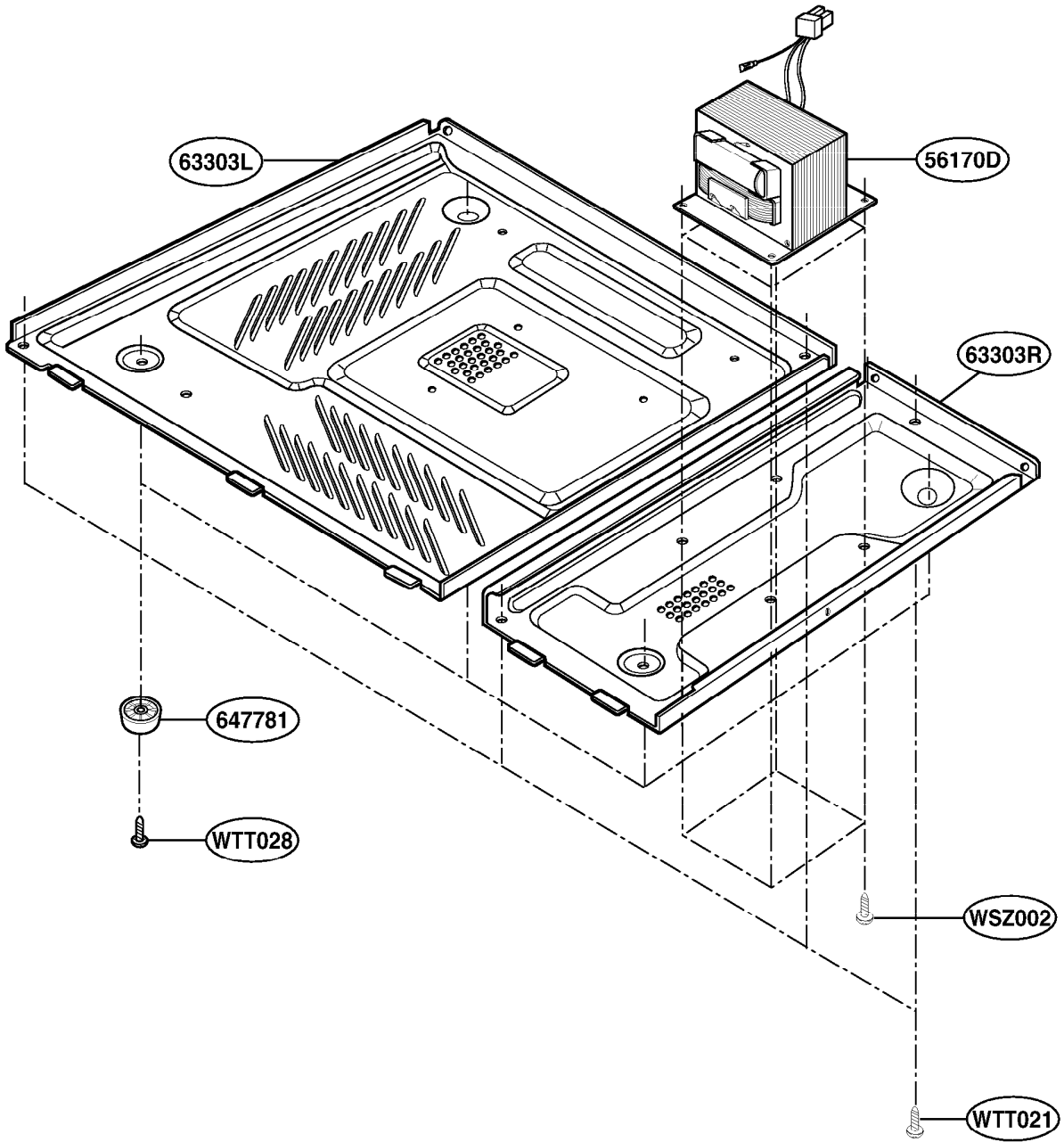



# SENSOR PARTS

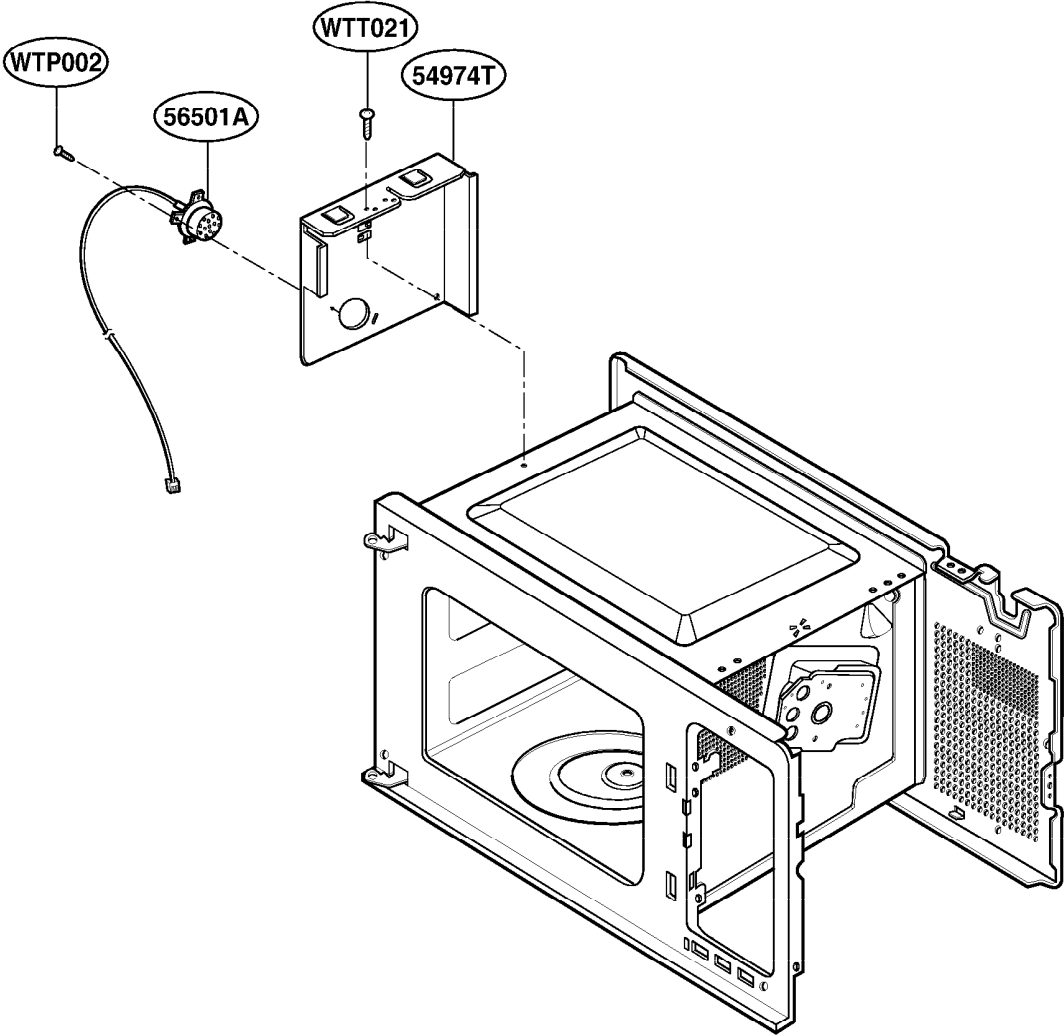

# SCHEMATIC DIAGRAM OF P.C.B.

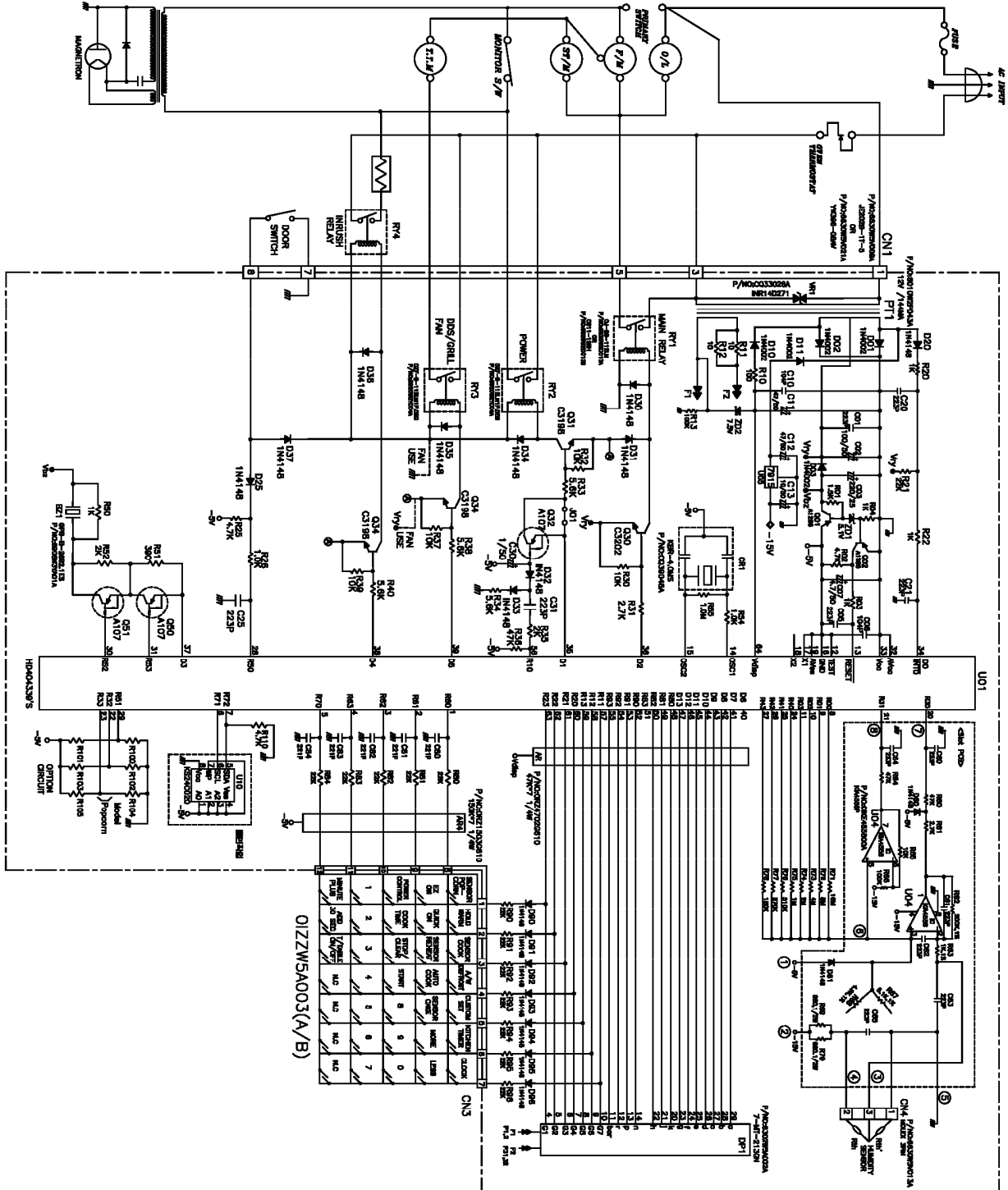

# PRINTED CIRCUIT BOARD

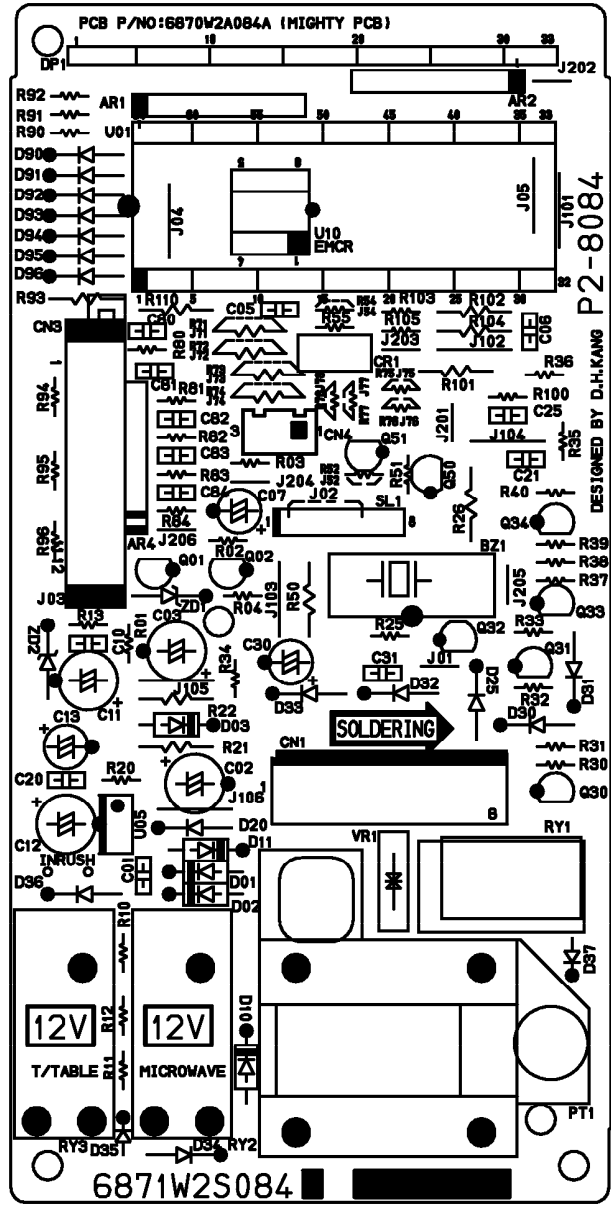
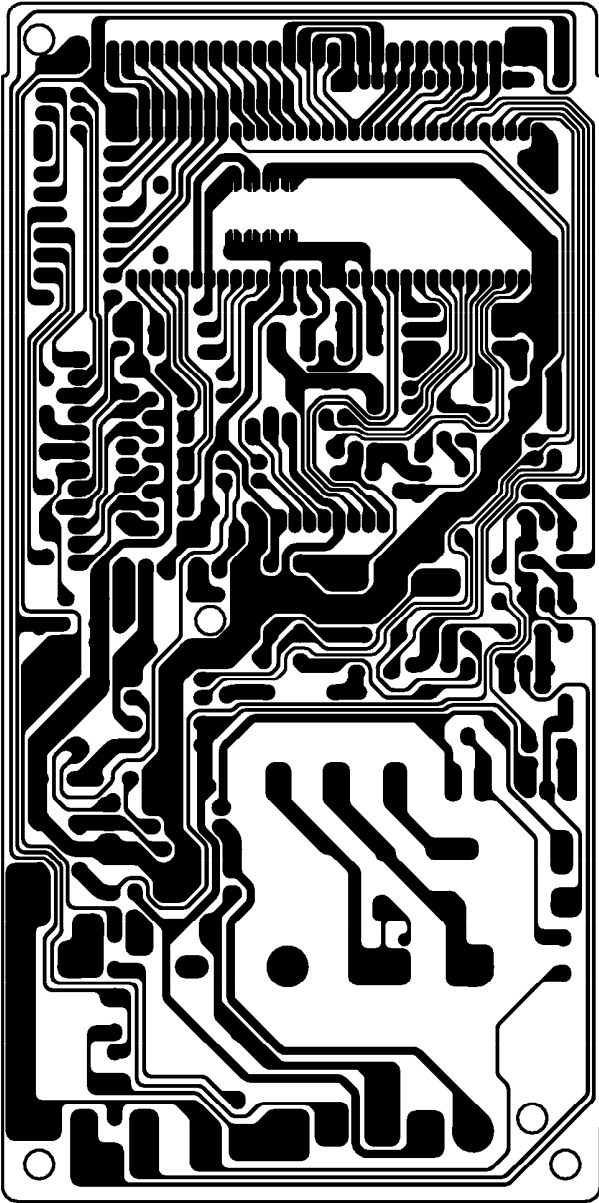



P/NO : 3828W5S0980

Feb, 1999  
Printed in Korea