

This Owner's Manual is provided and hosted by [Appliance Factory Parts](#).

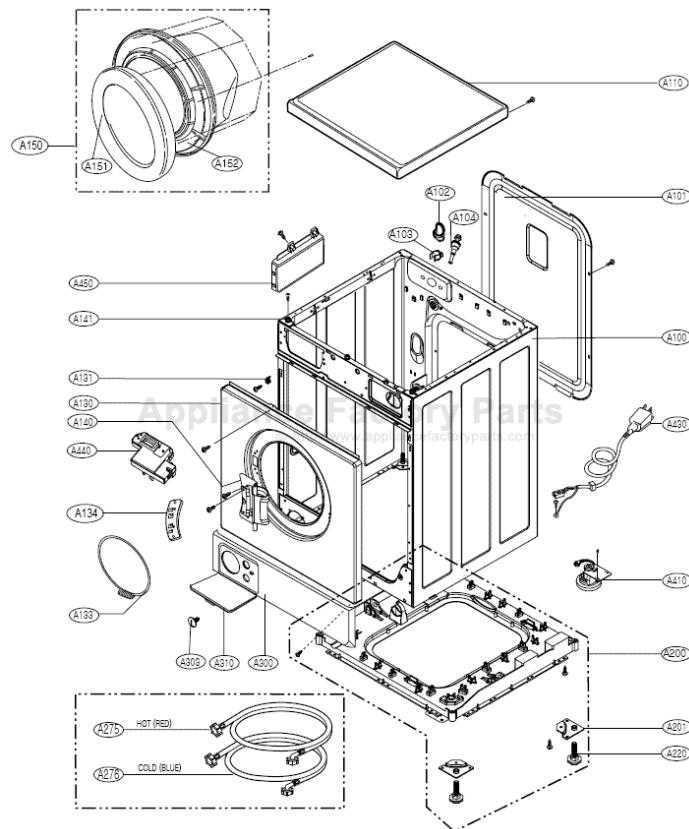

LG WD-1243FHB Owner's Manual

[Shop genuine replacement parts for LG WD-1243FHB](#)



[Find Your LG Washer Parts - Select From 393 Models](#)

----- Manual continues below -----



website : <http://www.LGService.com>

e-mail : <http://LGService.com/techsup.html>

WASHING MACHINE SERVICE MANUAL

CAUTION

READ THIS MANUAL CAREFULLY TO DIAGNOSE TROUBLE
CORRECTLY BEFORE OFFERING SERVICE.

**MODEL : WD-803(4)0(W)(F)(H)
WD-803(4)0F(H)(B)
WD-1042F(H)(B)
WD-1041(3)F(H)(B)
WD-102(4)1(5)W(F)(H)
WD-102(4)(5)F(H)(B)
WD-1223(5)F(H)(B)
WD-1243(5)F(H)(B)**



LG Electronics Inc.

JUN. 2001 PRINTED IN KOREA

P/No.:3828ER3008B

CONTENTS

1. SPECIFICATION.....	3
2. FEATURES & TECHNICAL EXPLANATION	4
3. PARTS IDENTIFICATION	6
4. INSTALLATION	7
5. OPERATION.....	10
6. WIRING DIAGRAM	18
7. PROGRAM CHART	19
8. TROUBLESHOOTING.....	20
8-1. BEFORE PERFORMING SVICE	20
8-2. QC TEST MODE.....	20
8-3. HOW TO KNOW THE WATER LEVEL FREQUENCY.....	21
8-4. ERROR DISPLAY	22
9. ERROR DIAGNOSIS AND CHECK LIST	26
9-1. DIAGNOSIS AND ANSWER FOR ABNORMAL OPERATION	26
9-2. FAULT DIAGNOSIS AND TROUBLESHOOTING	29
10. DISASSEMBLY INSTRUCTIONS	39
11. EXPLODED VIEW AND PART LIST	47
11-1. THE EXPLODED VIEW OF CABINET ASSEMBLY.....	47
11-2. THE EXPLODED VIEW OF CONTROL PANEL & DISPENSER ASSEMBLY	48
11-3. THE EXPLODED VIEW OF DRUM & TUB ASSEMBLY.....	49
※ APPENDIX(Replacement parts list)	50

1. SPECIFICATION

ITEM		WD-1223(5)F(H)(B) WD-1243(5)F(H)(B) WD-1041(3)F(H)B WD-1042F(H)B WD-102(4)1F(H)B WD-803(4)0F(H)B	WD-803(4)0(W)(F)(H) WD-102(4)1W(F)(H) WD-1042F(H)
POWER SUPPLY		220V - 240V~, 50Hz	
PRODUCT WEIGHT		63kg	67kg
ELECTRICITY CONSUMPTION	WASHING	120W	190W
	SPIN (800rpm)	300W	
	DRAIN MOTOR	32W	
	WASH HEATOR	2000W	
REVOLUTION SPEED	WASH	45 rpm	
	SPIN	600/800/1000/1200 rpm 400/600/800/1000 rpm [WD-1041(3)F(H)B / WD-1042F(H)B / WD-102(4)1(5)F(H)B] No Spin/500/800 rpm[WD-803(4)0F(H)B]	600/800/1000 rpm No Spin/500/800 rpm[WD-803(4)0(W)(F)(H)]
OPERATION WATER PRESSURE		0.3-10kgf/cm ² (30-1000kPa)	
CONTROL TYPE		Electronic	
WASH CAPACITY		7.0kg Wool (2.0kg), Synthetic (4.0), Delicate (3.0kg)	
DIMENSION		600mm (W) x 600mm (D) x 850mm (H)	
WASH PROGRAM		Coloreds, Whites, Rapid, Synthetic, Wool, Delicate	
RINSE PROGRAM		Normal, Super, Normal+Rinse Hold, Super+Rinse Hold	
DOOR SWITCH TYPE		Automatic type by pressing the button	
WATER LEVEL		9 steps (by sensor)	
SENSING OF THE LAUNDRY AMOUNT		Adapted	
NEURO - FUZZY		Adapted	
DISPLAY OF THE REMAINING TIME		Adapted	
DIAGNOSIS ERROR		10 ITEMS	7 ITEMS
POWER AUTO OFF		Adapted	
AUTO RESTART		Adapted	
CHILD LOCK		Adapted	

2. FEATURES & TECHNICAL EXPLANATION

2-1.FEATURES



■ **Jumbo drum**

Jumbo drum can wash about 40% more per load than conventional washing machine. A bigger drum improves the wash performance.

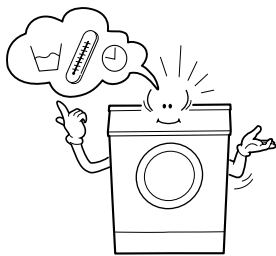

■ **More economical by Fuzzy Logic System**

FUZZY Logic System detects the amount of load and water temperature, and then determines the optimum water level and washing time to minimize energy and water consumption.

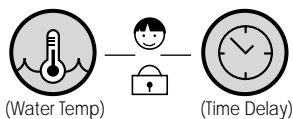

■ **Child-Lock**

The Child-Lock system has been developed to prevent children from pressing any button to change the programme during operation.

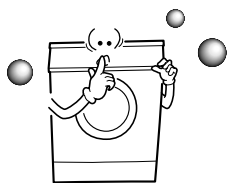

■ **Low noise speed control system**

By sensing the amount of load and balance, automatical distributes load evenly to minimize the spinning noise level.

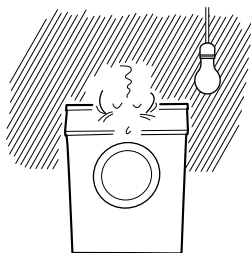

■ **Auto Restart**

Although the washing machine is turned off by a power failure, it restarts automatically where it stopped process when power is supplied again. It will be the same when the machine is unplugged and is plugged in again.

2-2.DETERMINE WASHING TIME BY FUZZY LOGIC

To get the best washing performance optimal time is determined by sensing of water temperature, selected washing temperature and laundry amount.

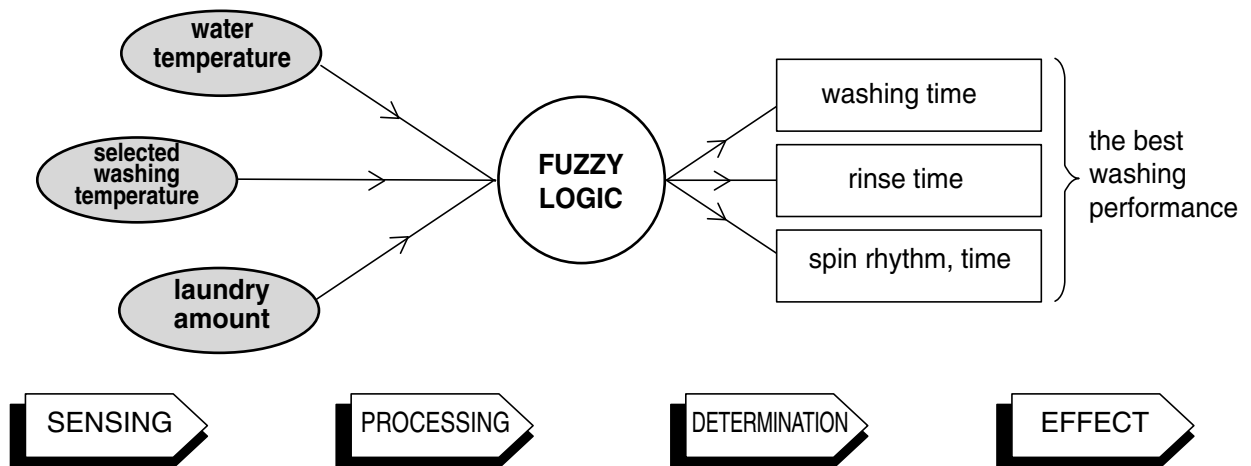

2-3.WATER LEVEL CONTROL

- This model adopts a pressure sensor which can sense the water level in the tub.
- When the water level reaches to the preset level the water supply is stopped, then the washing program proceeds.
- Spinning does not proceed until the water in the tub reduces a certain level.

2-4.THE DOOR CAN NOT BE OPENED

- While program is operating.
- While Door Lock light turns on.

3. PARTS IDENTIFICATION

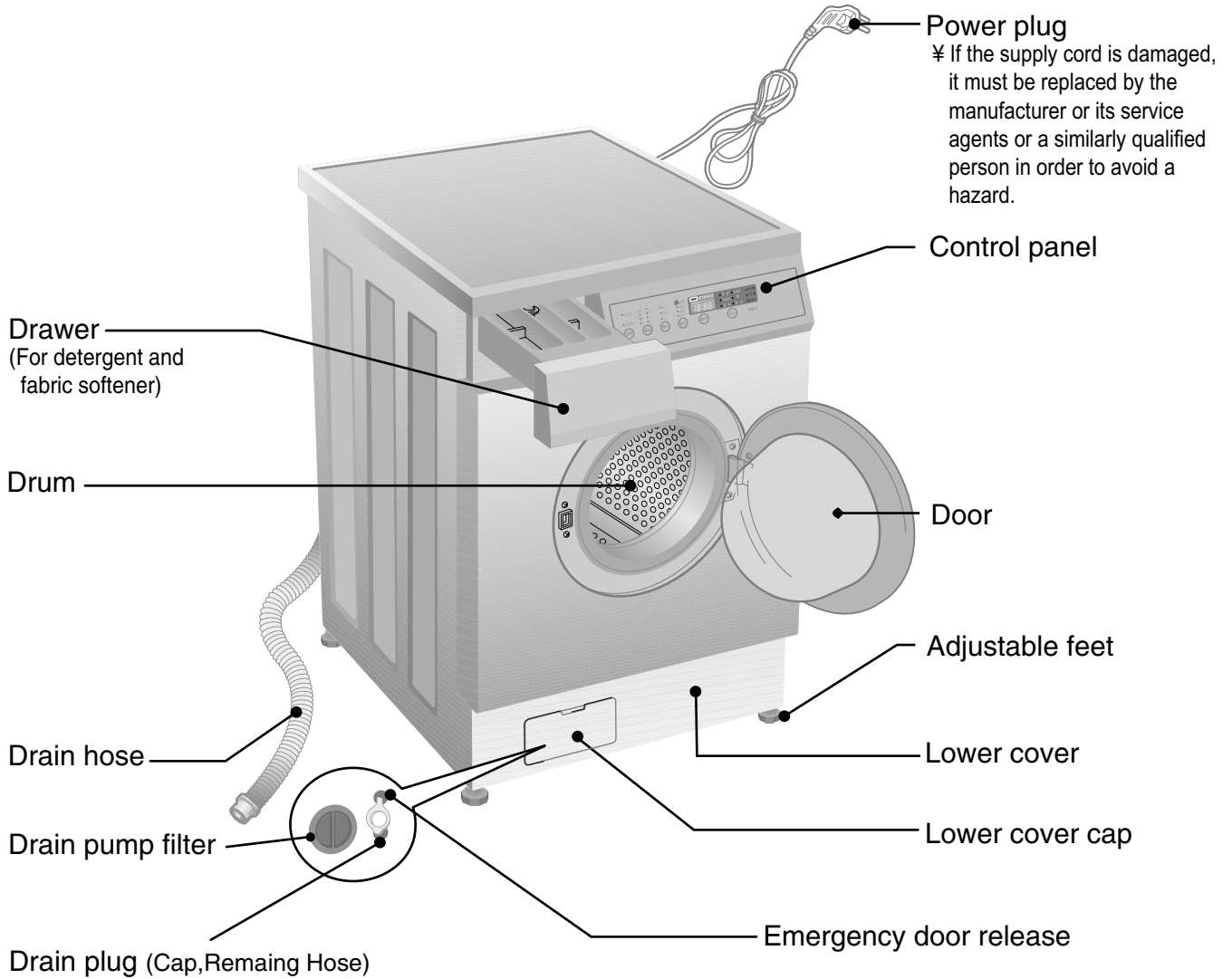

■ ACCESSORIES

* Option : Cold - 1EA
Cold/Hot - 2EA

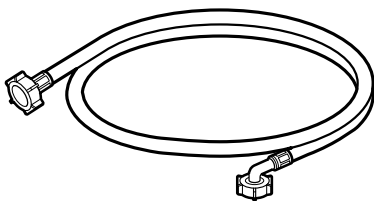

Inlet hose

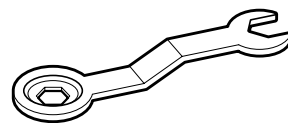

Wrench(1EA)

4. INSTALLATION

- ① Before servicing ask the customer what the trouble is.
- ② Check the adjustment (power supply is 220-240V, remove the transit bolts....)
- ③ Check the troubles referring to the troubleshooting.
- ④ Decide service steps referring to disassembly instructions.
- ⑤ Then, service and repair.
- ⑥ After servicing, operate the appliance to see whether it works O·K or NOT.

■ STANDARD INSTALLATION

The appliance should be installed as follows.

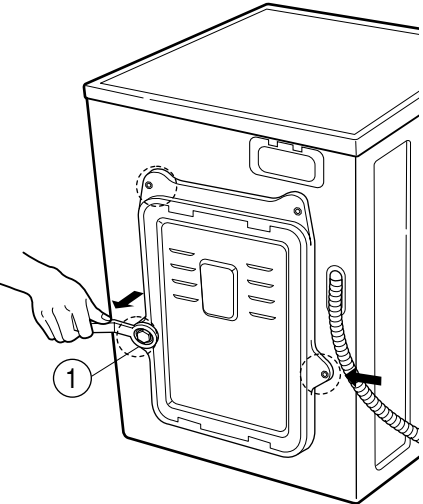
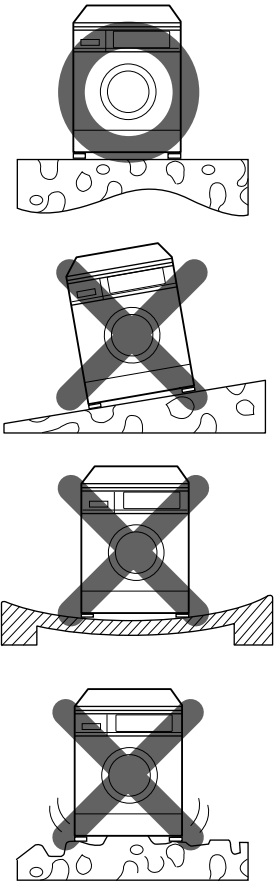
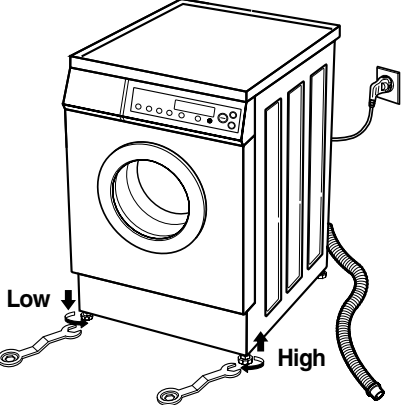
REMOVE THE TRANSIT BOLTS	INSTALL THE APPLIANCE ON FLAT AND FIRM SURFACE	ADJUST THE HORIZONTAL
<ul style="list-style-type: none"> • Remove the transit bolts (4EA: ①) with supplied spanner. • Keep the transit bolts and spanner for future use. 		<ul style="list-style-type: none"> • Turn the adjustable feet to set the appliance horizontally.  <ul style="list-style-type: none"> • The appliance goes up by rotating the feet clockwise. • The appliance comes down by rotating the feet counter-clockwise.

■ HOW TO CONNECT INLET HOSE

- Check that the rubber washer is inside of the valve connector.
- Connect the inlet hose firmly to prevent leak.

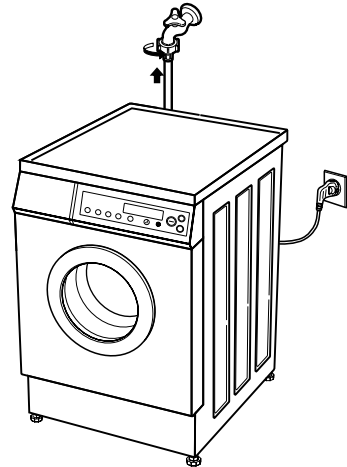

■ CONNECT DRAIN HOSE

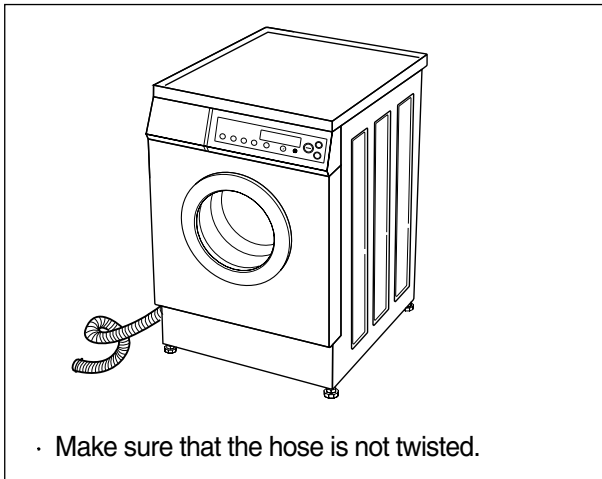

※ The drain hose should be placed under 100cm from the floor.

■ CONNECT POWER PLUG

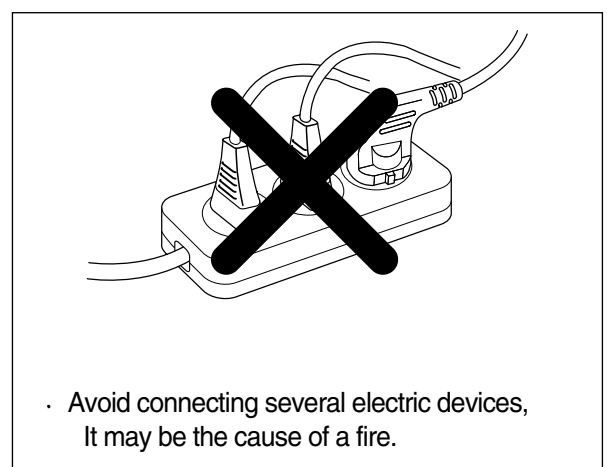
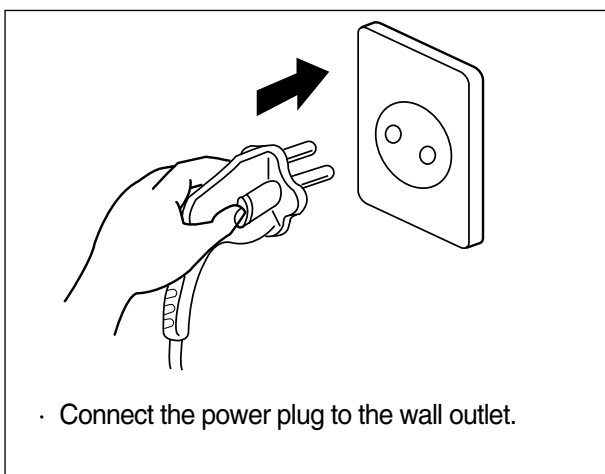

7 TEST OPERATION

1 Preparation for washing.

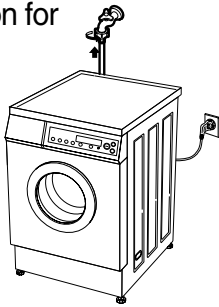

- Connect the power plug to the outlet.
- Connect the inlet hose.

2 Press the POWER () button.



- In case of coloreds program.

3 Press the PROGRAM () button.





- In case of coloreds program.

4 Press the (START/PAUSE) () button.

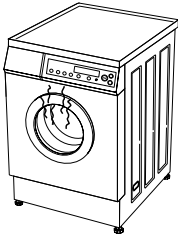

7 Check the water heating.



- Press the button (WATER TEMP) () and then the present temperature in displayed.

6 Check automatic reverse turn.

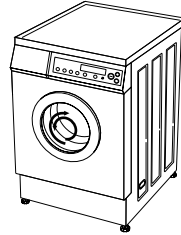

- Check if the drum rotates to clockwise and counterclockwise.

5 Check the water supply.

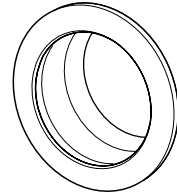



- Check shower because the water supplied on the door at first.

8 Check the drain and spin

• Pre	• Rinse hold	• 1200
• Main	• Super	• 1000
	• Normal	• 800
		• 600
		• no Spin



(Wash)

(Rinse)

(Spin)

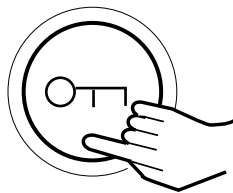
9 Power off



- After power off, press the DOOR OPEN () button to check the door open.

10 Water removal



- If SVC is needed, during check and remove the remaining water by pulling out the hose cap.



- Troubleshooting refer to (8-4.ERROR DISPLAY)
- Assemble and disassemble refer to (10.Disassembly Instructions)

5. OPERATION

■ WD-1223(5)F(H)(B) / WD-1243(5)F(H)(B)

※ () : WD-1041(3)F(H)B / WD-102(4)1(5)F(H)B

Rinse hold

- Rinse hold function can be selected by pressing the rinse () button, and rinse hold lamp turns ON.
- Selection rinse hold washer waits without drain / spinning after rinse.
- To drain and spin, press rinse () button, rinse hold lamp turns off and drain / spinning starts.

Displaying abnormal operation

- Display the remaining time (Hour : Minute)
- The remaining time is reduced by the washing cycle.
- Error lamp is indicated the abnormal operation. (*DE, FE, PE, CE, LE, SE, EE*)
- Display the reservation time.

For manual wash, rinse, and spin

- Use these buttons to change washing method, rinse method spinning speed.
- When lamp is off, no selection has been made.
- Prewashing is available for coloreds, whites, and synthetic program.

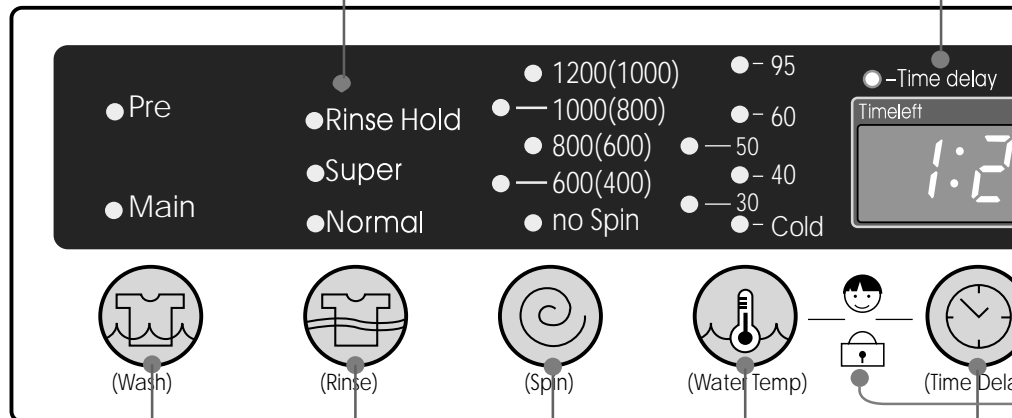

How to select water temperature

- Press the button to select water temperature.
- The water temperature can be selected [40°C → 50°C → 60°C → Cold → 30°C] during coloreds, or synthetic programs.
- 95°C is selected only for whites program.
- By pressing the button while operating the present temperature is displayed.

How to use delayed washing

- Press the button when reservation washing is needed.
- When the button is pressed, 「3:00」 is displayed. A maximum delay of 「19:00」 hours can be set.
- Whenever pressing it, one hour increases.
- [Time delay] the power () button to cancel it.
- [Time delay] means the time required from the present to the completion of washing.

How to select a program

- 6 programs can be selected by the kind of the laundry.
- By pressing the program () button, [Coloreds→Whites→Rapid→Delicate→Wool→Synthetic] can be selected.

Error display

- The display blinks if there is an error.
- no inlet : Trouble with water supply.
- imbalance : The laundry is tilted to one side.
- no drain : The drain filter is clogged or the drain pump is out of order.



Power button

- By pressing the button, it repeats turning on and off.
- Press the button to cancel the time delay.
- It turns off in 8 sec. after the program is finished.

Start/Pause button

- Use the button to start or pause wash cycle.
- The power turns off automatically in 4 minutes after the pause button is pressed.
- Press the button to change the program.

Child-Lock

- Once Child-Lock is set, all buttons are inoperable during operation.
- The Child-Lock system can be set at any time even including during Power Off, on Pause and operation. It is automatically cancelled when an operational error occur and when the cycle ends.
- When power is off, the LED indicates [] only. During operation, or when the program paused the LED Will indicate [] and the remaining time.

Door lock display

- It shows whether the door can be open or not during the washing cycle.
- If the lamp is off, the door can be opened.

How to open the door

- Use the button to add the laundry.
- Press the button to open the door.
- Only operates when the power plug is connected to 220-240V~ outlet.

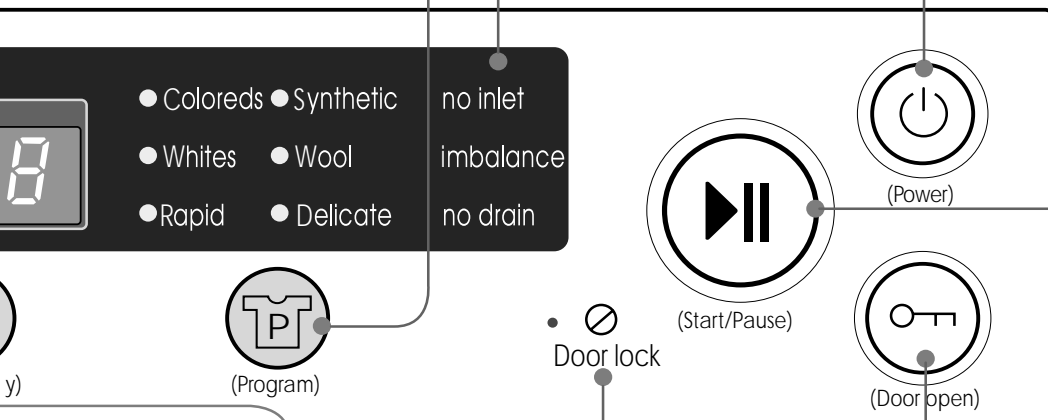

■ WD-1021(5)W(F)(H)/WD-1041(5)W(F)(H)

Rinse hold

- Rinse hold function can be selected by pressing the rinse button, and rinse hold lamp turns ON.
- Selection rinse hold washer waits without drain / spinning after rinse.
- To drain and spin, press rinse button, rinse hold lamp turns off and drain / spinning starts.

Displaying abnormal operation

- Display the remaining time (Hour : Minute)
- The remaining time is reduced by the washing cycle.
- Error lamp is indicated the abnormal operation. (*UE, FE, FE*)
- Display the reservation time.

For manual wash, rinse, and spin

- Use these buttons to change washing method, rinse method spinning speed.
- When lamp is off, no selection has been made.
- Prewashing is available for coloreds, whites, and synthetic program.

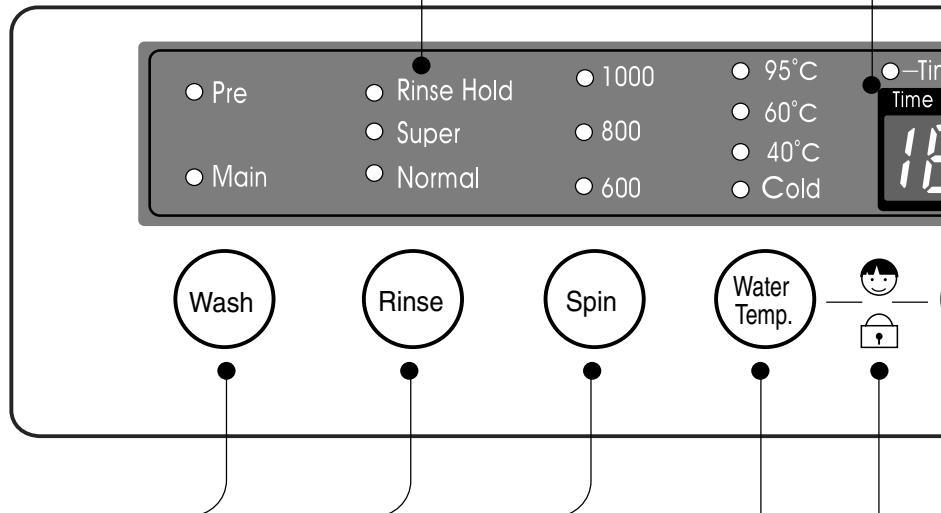

How to select water temperature

- Press the button to select water temperature.
- The water temperature can be selected [40°C → 60°C → Cold] during coloreds, or synthetic programs.
- 95°C is selected only for whites program.
- By pressing the button while operating the present temperature is displayed.

How to use delayed washing

- Press the button when reservation washing is needed.
- When the button is pressed, 「 3:00 」 is displayed. A maximum delay of 「 19:00 」 hours can be set.
- Whenever pressing it, one hour increases.
- Use the power button to cancel it.
- [Time delay] means the time required from the present to the completion of washing.

How to select a program

- 6 programs can be selected by the kind of the laundry.
- By pressing the program button, [Coloreds → Whites → Rapid → Delicate → Wool → Synthetic] can be selected.

Error display

- The display blinks if there is an error.
- **no inlet** : Trouble with water supply.
- **imbalance** : The laundry is tilted to one side.
- **no drain** : The drain filter is clogged or the drain pump is out of order.



Power button

- By pressing the button, it repeats turning on and off.
- Press the button to cancel the time delay.
- It turns off in 8 sec. after the program is finished.

Start/Pause button

- Use the button to start or pause wash cycle.
- The power turns off automatically in 4 minutes after the pause button is pressed.
- Press the button to change the program.

Child-Lock

- Once Child-Lock is set, all buttons are inoperable during operation.
- The Child-Lock system can be set at any time even including during Power Off, on Pause and operation. It is automatically cancelled when an operational error occur, and when the cycle ends.
- When power is off, the LED indicates [] only. During operation, or when the program paused the LED Will indicate [] and the remaining time.

Door lock display

- It shows whether the door can be open or not during the washing cycle.
- If the lamp is off, the door can be opened.

How to open the door

- Use the button to add the laundry.
- Press the button to open the door.
- Only operates when the power plug is connected to 220-240V~ outlet.

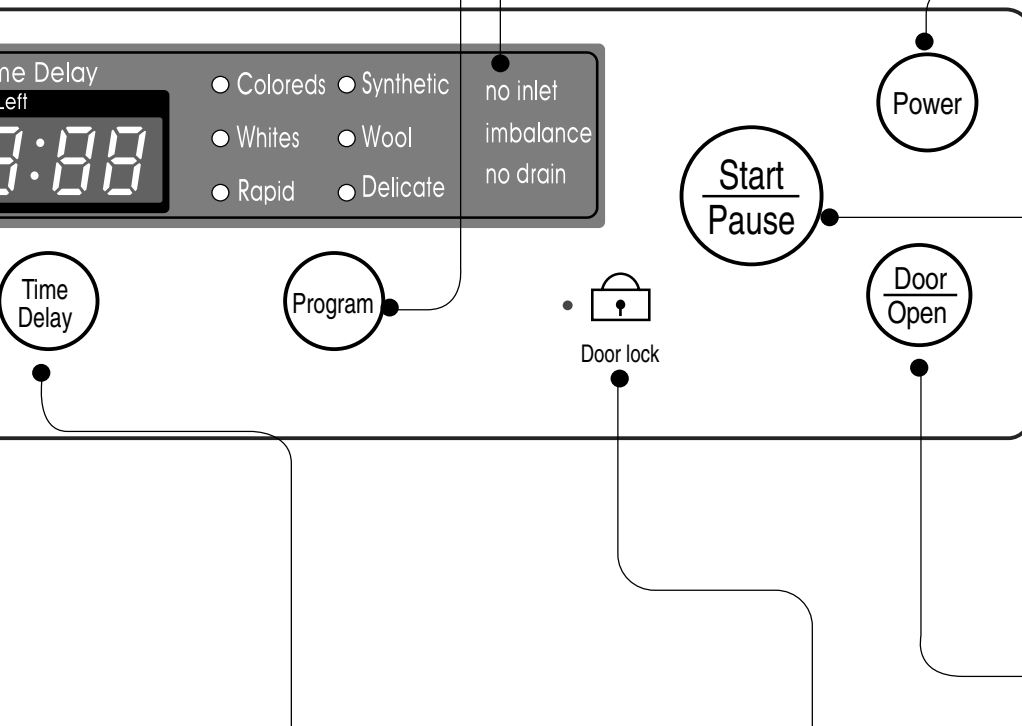

■ WD-8030(W)(F)(H)/WD-8040(W)(F)(H)/WD-1042F(H)

Rinse hold

- If you desire to leave fabrics in the machine without spinning after rinse to prevent them getting wrinkled, you may select rinse Hold by pressing the Rinse button.
- To drain and spin, press the rinse button to turn off the rinse Hold lamp.

Water temperature selector

- Press the button to select water temperature.
- The water temperature [40° C → 60° C → cold] during coloreds program.
- 95° C is selected only for White program.

※ ():WD-1042F(H)

● Pre	● Rinse Hold	● 800 (1000)	● 95 °C	● Eco
● Main	● Super	● 600 (800)	● 60 °C	● Chi
	● Normal	● no Spin (600)	● 40 °C	
			● Cold	

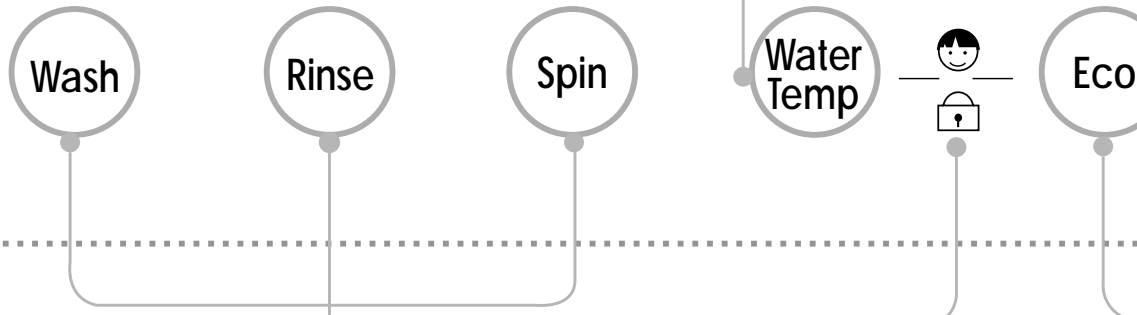

For manual wash, rinse and spin speed

- Use these buttons to change washing method, rinse method and spin speed.
- When lamp is off, no selection has been made.
- Prewash is available for Coloreds, Whites, Synthetic program.

Child - lock

- The Child Lock system can be programme and canceled by pressing both [Water Temp.] and [Eco] simultaneously. Once this system is set, all button are inoperable work during operation. (Child Lock Lamp is on on when it is selected.)
- The Child Lock system can be set at any time even including during Power-Off on. Pause and operation. It is automatically cancelled when operational error occur and when end of the cycle ends.

Wash program selector

- 6 programs can be set depending on the type of the laundry.
- If the power button is pressed. Coloreds program is automatically set.
- By pressing the button, [Coloreds → Whites → Rapid → Delicate → Wool → Synthetic] can be selected.

Start/Pause button

- Use the button to start or pause wash cycle.
- The power turns off automatically 4 minutes after the pause button is pressed.

Power button

- Press the button to turn power on and off.

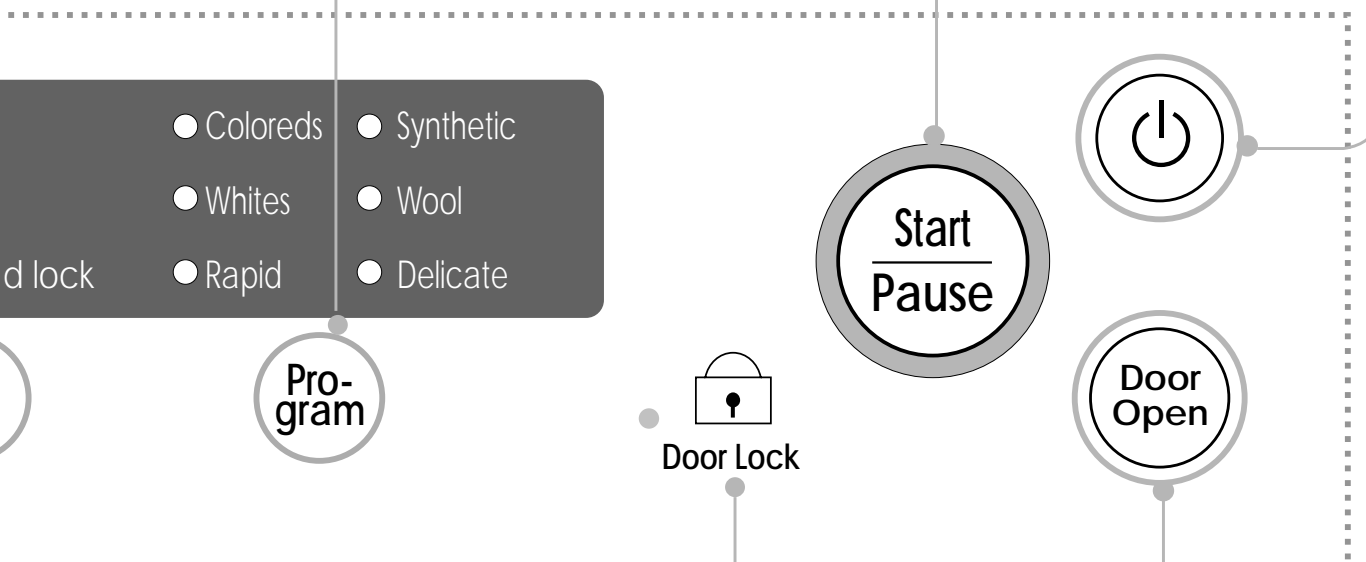

Eco button

- If you press the Eco button in while Whites program, Eco function is selected. Eco function gives you almost the same washing effect as that in 95 with less energy consumption.

Door lock display

- It shows whether the door can be open or not during the washing cycle.
- If the light is off, the door can be opened.

Door lock display

- Press the button to open the door.
- Only operate when power plug is connected.

Rinse hold

- If you desire to leave fabrics in the machine without spinning after rinse to prevent them getting wrinkled, you may select rinse Hold by pressing the Rinse button.
- To drain and spin, press the Rinse button to turn off the rinse Hold lamp.

Water temperature selector

- Press the button to select water temperature.
- The water temperature [40° C → 50° C → 60° C → cold → 30° C] during Coloreds program.
- 95° C is selected only for White program.

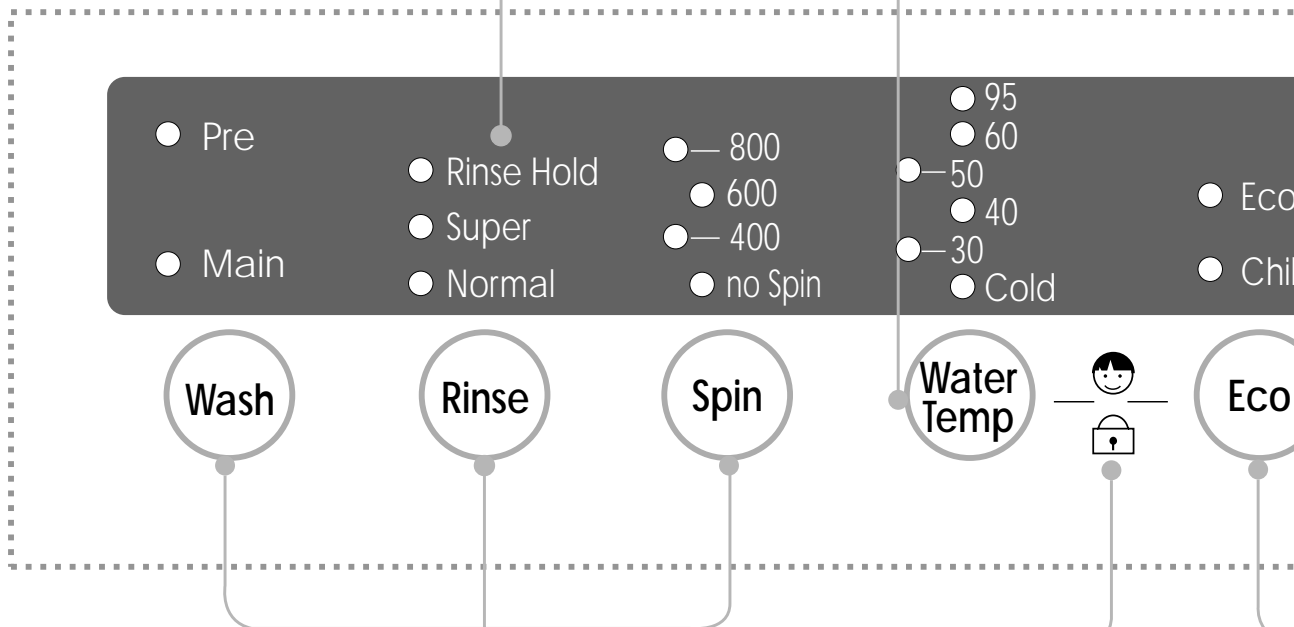

For manual wash, rinse and spin speed

- Use these buttons to change washing method, rinse method and spin speed.
- When lamp is off, no selection has been made.
- Prewash is available for Coloreds, Whites, Synthetic program.

Child - lock

- The Child Lock system can be programme and canceled by pressing both [Water Temp.] and [Eco] simultaneously. Once this system is set, all button are inoperable work during operation. (Child Lock Lamp is on on when it is selected.)
- The Child Lock system can be set at any time even including during Power-Off on. Pause and operation. It is automatically cancelled when operational error occur and when end of the cycle ends.

Wash program selector

- 6 programs can be set depending on the type of the laundry.
- If the power button is pressed. Coloreds program is automatically set.
- By pressing the button, [Coloreds → Whites → Rapid → Delicate → Wool → Synthetic] can be selected.

Start/Pause button

- Use the button to start or pause wash cycle.
- The power turns off automatically 4 minutes after the pause button is pressed.

Power button

- Press the button to turn power on and off.

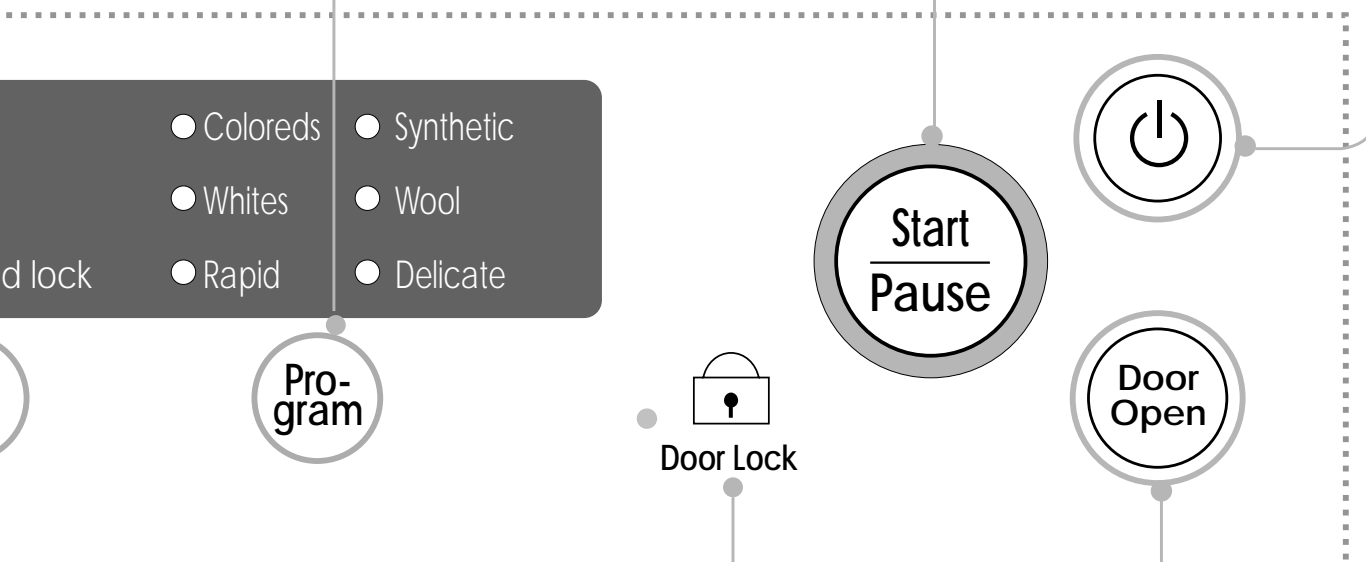

Eco button

- If you push the Eco button in while Whites program, Eco function is selected. Eco function gives you almost the same washing effect as that in 95 with less energy consumption.

Door lock display

- It shows whether the door can be open or not during the washing cycle.
- If the light is off, the door can be opened.

Door lock display

- Press the button to open the door.
- Only operate when power plug is connected.

6. WIRING DIAGRAM

■ WD-1223(5)F(H)(B) / WD-1243(5)F(H)(B) / WD-1041(2)(3)F(H)(B)
 WD-102(4)1(5)F(H)(B) / WD-803(4)0F(H)(B)

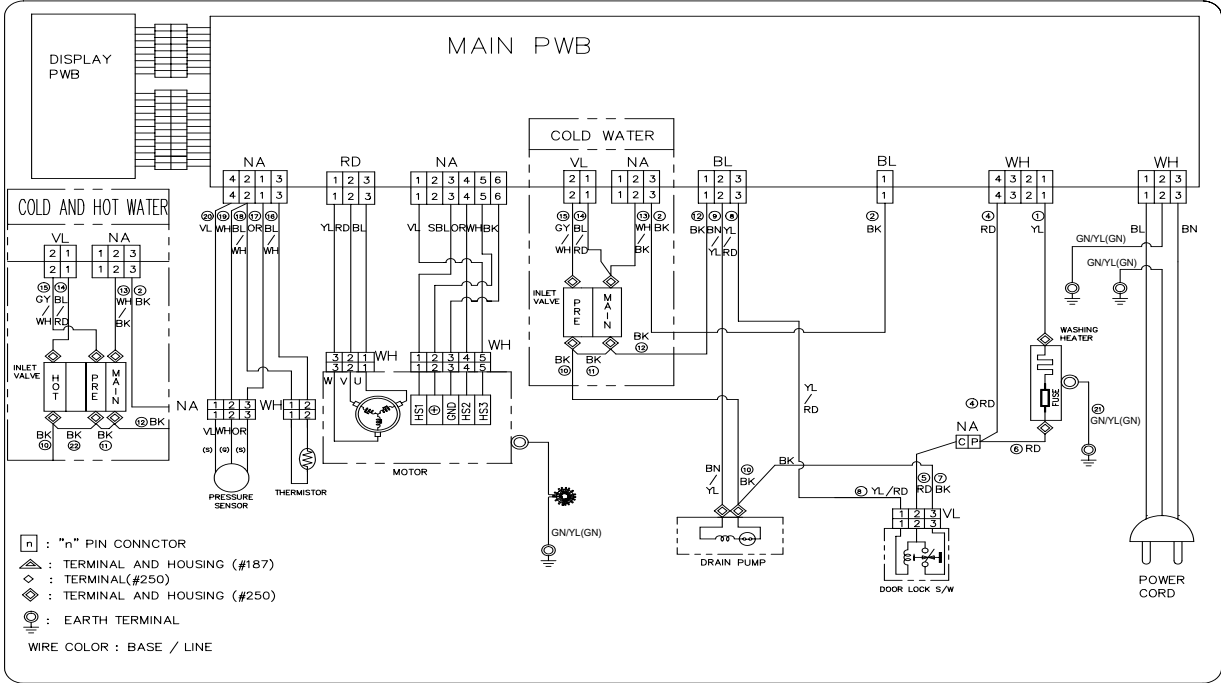

■ WD-803(4)0(W)(F)(H) / WD-102(4)1(5)W(F)(H) / WD-1042F(H)

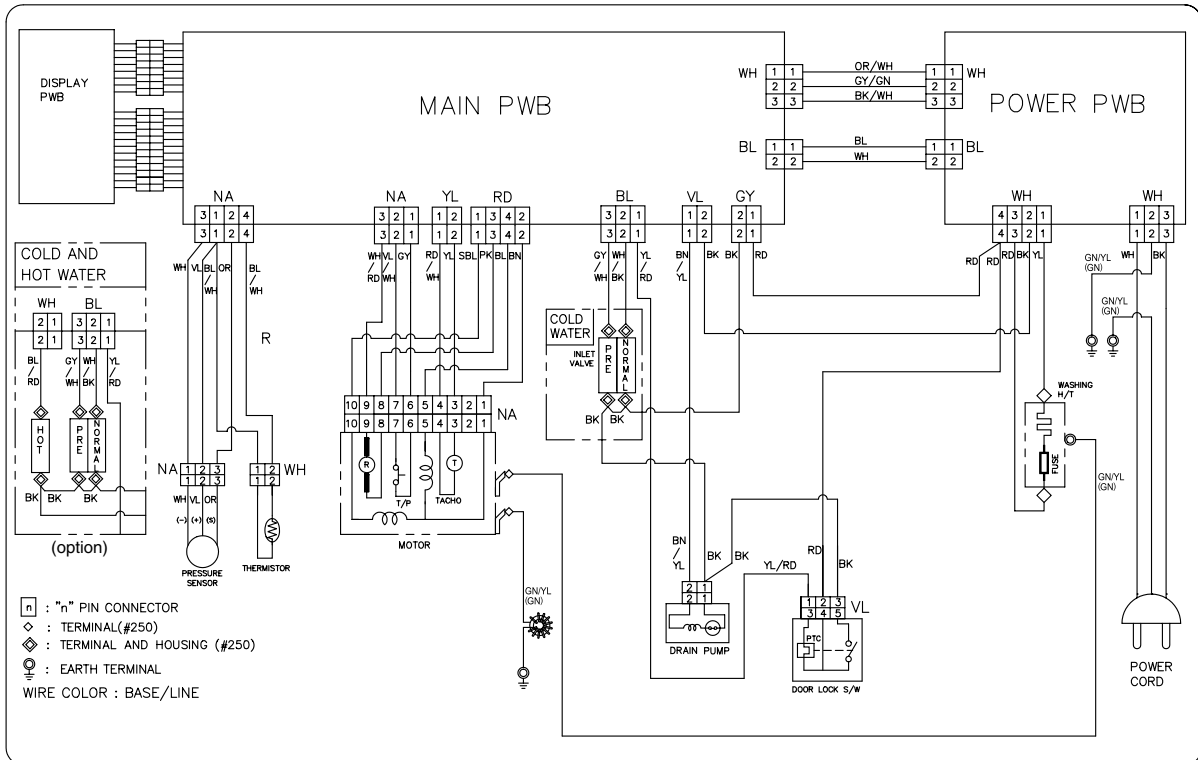

7. PROGRAM CHART

■ WD-8030(4)(W)(F)(H) / WD-102(4)1(5)W(F)(H) / WD-1042F(H) / WD-1223(5)F(H)(B) / WD-1243(5)F(H)(B)

* Water Supply : W-S * Intermittent Spin : I-S * Disentangle : D-T

CYCLE STEP Time (SEC)	Washing										Rinse										Spin		AUTO OFF END 20	Normal Working Time (Hour:Minute)							
	Pre				Main						Normal (Hold)				Extra (Hold)				Spin	D-T											
	W.S	Washing	Drain	I-S	W.S	Washing	Staycooling	W.S	Rinsing	Drain	Drain	I-S	W.S	Rinsing	Drain	I-S	W.S	Rinsing			Drain	I-S			W.S	Rinsing	Drain	W.S	Rinsing	Drain	
	1	2	3	4	5	6	7	8	9	10	11	12	13	14	15	16	17	18	19	20	21	22			23	24	25	26	27	28	29
Coloreds	8				22																										About 1:46
Whites	8				51																										About 2:20
Rapid					43																										About 2:23
Delicate					10																										About 1:09
Wool					25																										About 46
Synthetic					15																										About 45
Washing	8				22																										About 1:08
Rinsing					51																										About 28
Rinsing Hold																															About 28
Spin																															About 11
Washing + Rinsing	8				22																										About 1:36
Washing + Spin	8				22																										About 1:13
Rinse + Spin					51																										About 38

- * Basic Cycle
- * Optional Cycle
- * Pre-Setting Time : Water Supply - 120 sec.
Drain - 60 sec.
- * ~ Time for varies as the temperature or the amount of laundry
- * For Wool or Synthetic course only 650 rpm is operated
- * Shower Rinsing : Rinsing time is 20 sec
- * Basic time is minute in washing chart
- * The actual program time can be varied with the load amount, water temperature or ambient temperature

■ WD-1041(3)F(H)B/803(4)0F(H)B/102(4)2F(H)B/102(4)5F(H)B

* Water Supply : W-S * Intermittent Spin : I-S * Disentangle : D-T

CYCLE STEP Time (SEC)	Washing										Rinse										Spin		AUTO OFF END 20	Normal Working Time (Hour:Minute)							
	Pre				Main						Normal (Hold)				Extra (Hold)				Spin	D-T											
	W.S	Washing	Drain	I-S	W.S	Washing	Staycooling	W.S	Rinsing	Drain	Drain	I-S	W.S	Rinsing	Drain	I-S	W.S	Rinsing			Drain	I-S			W.S	Rinsing	Drain	W.S	Rinsing	Drain	
	1	2	3	4	5	6	7	8	9	10	11	12	13	14	15	16	17	18	19	20	21	22			23	24	25	26	27	28	29
Coloreds	8				22																										About 1:46
Whites	8				51																										About 2:20
Rapid					43																										About 41
Delicate					10																										About 1:07
Wool					25																										About 46
Synthetic					15																										About 1:46
Washing	8				22																										About 1:08
Rinsing					51																										About 28
Rinsing Hold																															About 28
Spin																															About 11
Washing + Rinsing	8				22																										About 1:36
Washing + Spin	8				22																										About 1:13
Rinse + Spin					51																										About 38





- * Basic Cycle
- * Optional Cycle
- * Pre-Setting Time : Water Supply - 120 sec.
Drain - 60 sec.
- * ~ Time for varies as the temperature or the amount of laundry
- * For Wool or Synthetic course only 650 rpm is operated
- * Shower Rinsing : Rinsing time is 20 sec
- * Basic time is minute in washing chart
- * The actual program time can be varied with the load amount, water temperature or ambient temperature

8. TROUBLESHOOTING

8-1. BEFORE PERFORMING SERVICE

- Be careful of electric shock or disconnecting the parts while troubleshooting.
- Voltage of each terminal in AC 220-240V and DC while applying an electric current.

8-2. QC TEST MODE.

- ① Pressing RINSE (), and SPIN () button simultaneously.
- ② Power supply ON with pressing upper two button. then buzzer sound twice.
- ③ Press the START/PAUSE () button as follows.
[Press the START/PAUSE () button more 4 times until stop spinning]

- WD-1223(5)F(H)(B) / WD-1243(5)F(H)(B) / WD-102(4)1(5)W(F)(H)
WD-102(4)1(5)F(H)B / WD-1041(3)F(H)B

Pressing number of [START/PAUSE] button	Checking Point	Display Status
None	All lamps turn on	
1 time	Clockwise spin (right)	Motor rpm (About 45)
2 times	Low speed spin	Motor rpm (About 63~67)
3 times	High speed spin	Motor rpm (About 114~117)
4 times	Inlet valve for pre-wash operation	Water level frequency (25~65)
5 times	Inlet valve for main-wash operation	Water level frequency (25~65)
	Hot inlet valve in case of hot water fill	
6 times	Inlet valve for main-wash operation	Water level frequency (25~65)
7 times	Counterclockwise spin (left)	Motor rpm (About 45)
8 times	A Heater is in operation for 3 sec.	Water Temperature
9 times	Draining pump operation	Water level frequency
10 times	Auto off operation	

■ WD-803(4)0(W)(F)(H) / WD-803(4)0F(H)(B) / WD-102(4)2F(H)(B)

Times of press	Checking Point
None	All lamps turn on
1 time	Counterclockwise spin
2 times	Low speed Spin
3 times	High speed Spin
4 times	Inlet valve for pre-wash operation (Cold)
5 times (FOR WD-****FH)	Inlet valve for main-wash operation (Hot)
6 times	Inlet valve for main-wash operation (Cold)
7 times	Clockwise spin
8 times	The Heater is in operation for 3 sec.
9 times	Draining pump operation
10 times	Auto off operation

8-3. HOW TO KNOW THE WATER LEVEL FREQUENCY

■ WD-1223(5)F(H)(B)/WD-1243(5)F(H)(B)/WD-102(4)1(5)W(F)(H) / WD-1041(3)F(H)(B)

* Press the WASH and RINSE button simultaneously.

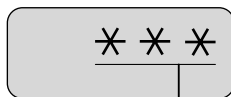







● The digits means water level frequency (10^{-1} KHz)

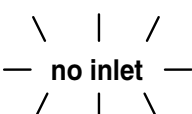
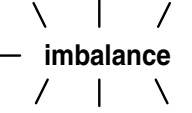
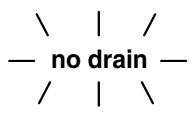

$$\begin{aligned} \text{ex) 241 : Water level frequency} &= 241 \times 10^{-1} \text{ KHz} \\ &= 24.1 \text{ KHz} \end{aligned}$$

8-4. ERROR DISPLAY.

■ WD-1223(5)F(H)(B)/WD-1243(5)F(H)(B)/WD-102(4)1(5)WF(H) / WD-1041(3)F(H)B

- If you press the [Start/Pause]  button when an error is displayed, any error except FE will disappear and the machine will change into pause status.
- In case of FE, LE, SE, if the error is not resolved within 20 sec. In the case of other errors, if the error is not resolved within 4 min. power will be turned off automatically and the error code will blink.

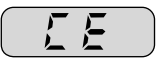
	ERROR	SYMPTOM	CAUSE
1	WATER INLET ERROR		<ul style="list-style-type: none"> ○ Water has not reached to the pre-set level within 4 min. since inlet valve operated, or water has not reached to the normal level within 25 min.
2	IMBALANCE ERROR		<ul style="list-style-type: none"> ○ The appliance is tilted. ○ Laundry is gathered to one side. ○ Non-distributable things are put into the drum.
3	DRAIN ERROR		<ul style="list-style-type: none"> ○ Water has not drained enough within 5 min.
4	OVERFLOW ERROR		<ul style="list-style-type: none"> ○ Water is automatically being pumped out because too much water is in the tub.
5	SENSOR PRESSURE S/W ERROR		<ul style="list-style-type: none"> ○ The sensor pressure switch is out of order.
6	DOOR OPEN ERROR		<ul style="list-style-type: none"> ○ The [Start/Pause]  button is pressed with the door open. ○ The door switch is out of order.
7	HEATING ERROR		<ul style="list-style-type: none"> ○ The thermistor is out of order.
8	SENSOR ERROR		<ul style="list-style-type: none"> ○ The connector (5-pin, male, white) in the wire harness is not connected to the connector (5-pin, female) of hall sensor in the MOTOR. 🔧 Reconnect or repair the contact in the connector.

	ERROR	SYMPTOM	CAUSE
8	SENSOR ERROR		<ul style="list-style-type: none"> • The electric contact between the connectors (5-pin, male in the wire harness and 5-pin female in the hall sensor) is bad or unstable. <ul style="list-style-type: none"> ☞ Reconnect or repair the contact in the connector. • The connector (6-pin, male, natural) in the wire harness is not connected to the connector (6-pin, female, natural) of PWB assembly (Main) or the electric contact of connectors is bad/unstable. <ul style="list-style-type: none"> ☞ Reconnect or repair the contact in the connector. • The electric contact between the connectors [6-pin, male in the wire harness and 6-pin female in the controller (Main)] is bad or unstable. <ul style="list-style-type: none"> ☞ Reconnect or repair the contact in the connector. • The wire harness between hall sensor in the MOTOR and PWB assembly (Main) is cut (open circuited). <ul style="list-style-type: none"> ☞ Repair/replace the damaged WIRE HARNESS. • The hall sensor is out of order/defective. <ul style="list-style-type: none"> ☞ Replace the motor. • The controller (Main) is out of order/defective. <ul style="list-style-type: none"> ☞ Replace the PWB assembly (Main).
9	CURRENT ERROR		<ul style="list-style-type: none"> • PWB assembly (Main) is out of order. <ul style="list-style-type: none"> ☞ Replace the PWB assembly (Main). • Winding in the MOTOR is short-circuited. <ul style="list-style-type: none"> ☞ Replace the MOTOR.
10	LOCK ERROR		<ul style="list-style-type: none"> • The connector (3-pin, male, white) in the wire harness is not connected to the connector (3-pin, female, white) of MOTOR. <ul style="list-style-type: none"> ☞ Reconnect or repair the connector. • The electric contact between the connectors [3-pin, male, white in the wire harness and 6 pin, female, white in the PWB assembly (Main)] is bad or unstable. <ul style="list-style-type: none"> ☞ Reconnect or repair the contact in the connector. • The wire harness between the MOTOR and PWB assembly (Main) is cut (open circuited). <ul style="list-style-type: none"> ☞ Repair the damaged (open-circuited) WIRE HARNESS. • The hall sensor is out of order/defective. <ul style="list-style-type: none"> ☞ Replace the PWB assembly (Main).

■ WD-8030(W)(F)(H)/WD-8040W(F)(H)/WD-1042F(H)/WD-803(4)0F(H)B/WD-102(4)2F(H)B







- If you press the [Start/Pause] button when an error is displayed, any error except **SENSOR PRESSURE S/W ERROR** will disappear and the machine will change into pause status.
- In case of 『**SENSOR PRESSURE S/W ERROR, THERMISTOR ERROR**』 if the error is not resolved within 20 sec. In the case of other errors, if the error is not resolved within 4 min. power will be turned off automatically and the error code will blink. But in case of 『**OVER FLOW ERROR**』, power will not be turned off.



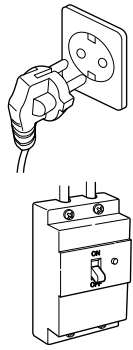
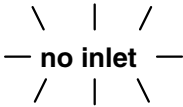

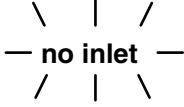



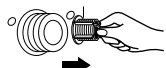





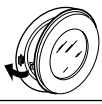





	ERROR	SYMPTOM	CAUSE
1	WATER INLET ERROR	☀ Pre ☀ Main	○ Water has not reached to the pre-set level within 4 min. since inlet valve operated, or water has not reached to the normal level within 25 min.
2	IMBALANCE ERROR	☀ Rinse Hold ☀ Super ☀ Normal	○ The appliance is tilted. ○ Laundry is gathered to one side. ○ Non-distributable things are put into the drum.
3	DRAIN ERROR	☀ 800 (1000) ☀ 600 (800) ☀ no Spin (600) ----- ☀ 1000 for ☀ - 800 WD-8030F(H)B ☀ 600 WD-8040F(H)B ☀ - 400 WD-1022F(H)B ☀ no spin WD-1042F(H)B	○ Water has not drained enough within 5 min. ※ () :WD-1042F(H)
4	OVERFLOW ERROR	☀ Coloreds ☀ Whites ☀ Rapid	○ Water is automatically being pumped out because too much water is in the tub.
5	SENSOR PRESSURE S/W ERROR	☀ Synthetic ☀ Wool ☀ Delicate	○ The sensor pressure switch is out of order.
6	DOOR OPEN ERROR	 Door Lock	○ The Start/Pause button is pressed with the door open. ○ The door switch is out of order.
7	THERMISTOR ERROR	☀ 95 C° ☀ 60 C° ☀ 40 C° ☀ Cold ----- ☀ - 95 for ☀ - 60 WD-8030F(H)B ☀ - 50 WD-8040F(H)B ☀ - 40 WD-1022F(H)B ☀ - 30 WD-1042F(H)B ☀ - Cold	○ The thermistor is out of order.

	ERROR	SYMPTOM	CAUSE
8	SENSOR ERROR	☀ (1000) ☀ - 800 ☀ Super ☀ 600 ☀ Normal ☀ - 400 ☀ no spin for WD-8030F(H)B / WD-8040F(H)B WD-1022F(H)B / WD-1042F(H)B	<ul style="list-style-type: none"> • The electric contact between the connectors (5-pin, male in the wire harness and 5-pin female in the hall sensor) is bad or unstable. <ul style="list-style-type: none"> ☞ Reconnect or repair the contact in the connector. • The connector (6-pin, male, natural) in the wire harness is not connected to the connector (6-pin, female, natural) of PWB assembly (Main) or the electric contact of connectors is bad/unstable. <ul style="list-style-type: none"> ☞ Reconnect or repair the contact in the connector. • The electric contact between the connectors [6-pin, male in the wire harness and 6-pin female in the controller (Main)] is bad or unstable. <ul style="list-style-type: none"> ☞ Reconnect or repair the contact in the connector. • The wire harness between hall sensor in the MOTOR and PWB assembly (Main) is cut (open circuited). <ul style="list-style-type: none"> ☞ Repair/replace the damaged WIRE HARNESS. • The hall sensor is out of order/defective. <ul style="list-style-type: none"> ☞ Replace the motor. • The controller (Main) is out of order/defective. <ul style="list-style-type: none"> ☞ Replace the PWB assembly (Main).
9	CURRENT ERROR	☀ Pre ☀ Rinse Hold ☀ Super ☀ Main ☀ Normal for WD-8030F(H)B / WD-8040F(H)B WD-1022F(H)B / WD-1042F(H)B	<ul style="list-style-type: none"> • PWB assembly (Main) is out of order. <ul style="list-style-type: none"> ☞ Replace the PWB assembly (Main). • Winding in the MOTOR is short-circuited. <ul style="list-style-type: none"> ☞ Replace the motor.
10	LOCK ERROR	☀ (1000) ☀ - 95 ☀ - 800 ☀ - 60 ☀ 600 ☀ - 50 ☀ - 400 ☀ - 40 ☀ no spin ☀ - 30 ☀ - Cold for WD-8030F(H)B / WD-8040F(H)B WD-1022F(H)B / WD-1042F(H)B	<ul style="list-style-type: none"> • The connector (3-pin, male, white) in the wire harness is not connected to the connector (3-pin, female, white) of MOTOR. <ul style="list-style-type: none"> ☞ Reconnect or repair the connector. • The electric contact between the connectors [3-pin, male, white in the Wire Harness and 6-pin, female, white in the PWB assembly (Main)] is bad or unstable. <ul style="list-style-type: none"> ☞ Reconnect or repair the contact in the connector. • The wire harness between the MOTOR and PWB assembly (Main) is cut (open circuited). <ul style="list-style-type: none"> ☞ Repair the damaged (open-circuited) WIRE HARNESS. • The hall sensor is out of order/defective. <ul style="list-style-type: none"> ☞ Replace the PWB assembly (Main).

9. ERROR DIAGNOSIS AND CHECK LIST

9-1. DIAGNOSIS AND ANSWER FOR ABNORMAL OPERATION

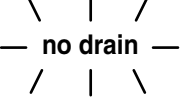
SYMPTOM	GUIDE FOR SERVICE CALL	
<p>NO POWER</p>	<p>Is the power plug connected firmly to 220-240V outlet?</p> <p style="text-align: center;">YES</p> <p>Power failure? or Breaker opened? Is the outlet controlled by a switch.</p> <p style="text-align: center;">NO</p> <p style="text-align: center;">Visit to check</p>	
<p>Water inlet trouble</p> <p style="text-align: center;">  no inlet </p> <p>  Pre  Main </p> <p> WD-803(4)0(W)(F)(H) WD-803(4)0F(H)(B) WD-102(4)2F(H)(B) </p>	<p>Is no inlet displayed?</p> <p style="text-align: center;">YES</p> <p>Is the tap opened?</p> <p style="text-align: center;">YES</p> <p>Is the tap frozen?</p> <p style="text-align: center;">NO</p> <p>Is the water supply shut-off?</p> <p style="text-align: center;">NO</p> <p>Is filter in the inlet valve clogged with foreign material?</p> <p style="text-align: center;">NO</p> <p style="text-align: center;">Visit to check</p>	<p style="text-align: center;">  no inlet </p>    <div style="border: 1px solid black; padding: 5px; margin-top: 10px;"> <p style="text-align: center;">Clean the filter of inlet valve</p>  </div>

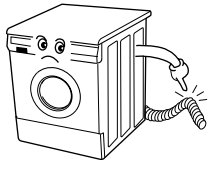
SYMPTOM	GUIDE FOR SERVICE CALL
<p>◦ Door open trouble</p> <p>◦ Error displayed on the program</p>   <p>Door Lock</p> <p>WD-803(4)0(W)(F)(H) WD-803(4)0F(H)(B) WD-102(4)2F(H)(B)</p>	<p>When the door opened, Is the started or on the program TIME DELAY () ?</p> <p>YES </p> <p>Close the door</p>  <p>NO</p> <p>Didn't you press the DOOR OPEN () button when water remained in the tub?</p> <p>YES</p> <p>1. Press the START/PAUSE () button to stop the appliance. 2. Drain water by selecting spin. 3. Open the door by pressing the DOOR OPEN () button.</p> <p>NO</p> <p>Isn't door opened in spite of pressing the DOOR OPEN () button</p> <p>NO</p> <p>Visit to check</p> <p>Check if the door switch is O · K.</p>
<p>◦ Drain trouble</p> <p>※ () : WD-1042F(H)</p>  <p>no drain</p> <p> 800 (1000)  600 (800)  no Spin (600)</p> <p>WD-803(4)0(W)(F)(H)</p> <hr/> <p> 1000 for WD-8030F(H)B  800 WD-8040F(H)B  600 WD-1022F(H)B  400 WD-1042F(H)B  no spin</p>	<p>Is no drain displayed?</p> <p>YES </p> <p>Is the foreign material clogged in the drain pump filter such as pins, coins etc.?</p> <p>YES Clean up the filter.</p>  <p>NO</p> <p>Is the Drain Hose frozen with water, kinked, or curshed?</p> <p>NO</p> <p>Visit to check</p> 

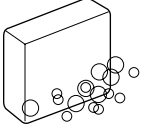
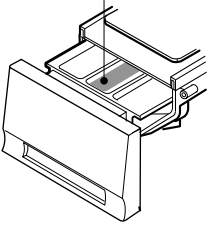
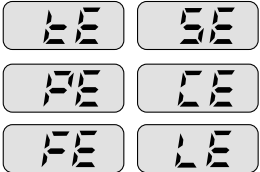
SYMPTOM	GUIDE FOR SERVICE CALL	
<p>◦ Lather overflow from the appliance.</p> <p>(In this condition, wash and spin do not operate normally)</p>	<p>Is low-lathering detergent for the drum washing machine used?</p> <p style="text-align: center;">↓ YES ↓</p> <p>Is the proper amount of detergent used as recommended?</p> <p style="text-align: center;">↓ YES ↓</p> <p>Recommend to reduce the amount of detergent.</p> <p>* This appliance has the automatic suds sensing function which operates under much suds condition for good rinse and preventing overflow.</p> <p>* When much suds are sensed, the suds removing function such as drain, water input, and pause will operate without rotating the drum.</p>	 <p>LOW SUDSING DETERGENT</p>
<p>◦ No effect of softener</p>	<p>Is softener put in the correct compartment of drawer?</p> <p style="text-align: center;">↓ YES ↓</p> <p>Is the drawer closed during wash?</p> <p style="text-align: center;">↓ YES ↓</p> <p>Is the softener cap clogged?</p> <p style="text-align: center;">↓ YES ↓</p> <p>Explain how to use softener</p> <p>Clean the compartment for softener</p>	<p>Compartment for softener</p> 
<p>◦ Error displayed as follows</p> <p>※ WD-1223(5)F(H)(B) WD-1243(5)F(H)(B) WD-102(4)1W(F)(H) WD-1041(3)F(H)B</p>	<p style="text-align: center;">Visit to check</p>	
<p>◦ Error displayed as follows</p> <p>※ WD-803(4)0(W)(F)(H) WD-1042F(H)</p>	<p style="text-align: center;">Visit to check</p> <p>◦ OVER FLOW ERROR ◦ PRESSURE SW ERROR ◦ THERMISTOR ERROR</p>	

9-2. FAULT DIAGNOSIS AND TROUBLESHOOTING

■ WD-1223(5)F(H)(B)/WD-1243(5)F(H)(B) / WD-1041(3)F(H)B / WD-102(4)1(5)F(H)B / WD-803(4)0F(H)B

CAUTION

1. Be careful of electric shock or disconnecting the parts while troubleshooting.
2. First of all, check the connection of each part terminal with wiring diagram.
3. Voltage of each terminal is AC 220-240V while applying an electric current.
(except secondary part of the transformer and sensor pressure)

NO POWER

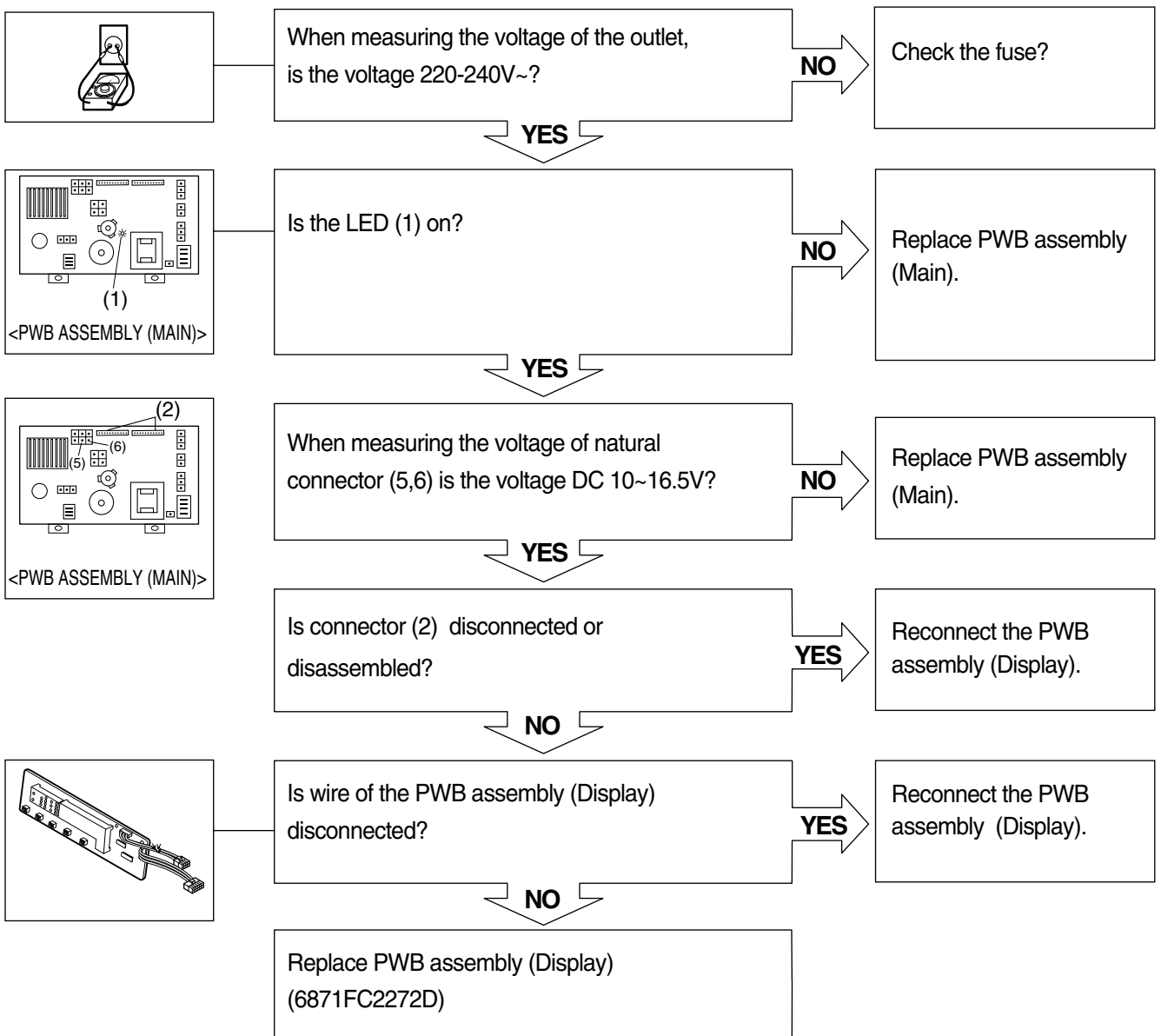

■ WD-803(4)0(W)(F)(H)/WD-102(4)1(5)W(F)(H)/WD-1042F(H)

CAUTION

1. Be careful of electric shock or disconnecting the parts while troubleshooting.
2. First of all, check the connection of each part terminal with wiring diagram.
3. Voltage between each terminal is AC 220-240V while applying an electric current.
(except secondary part of the transformer and sensors)

NO POWER

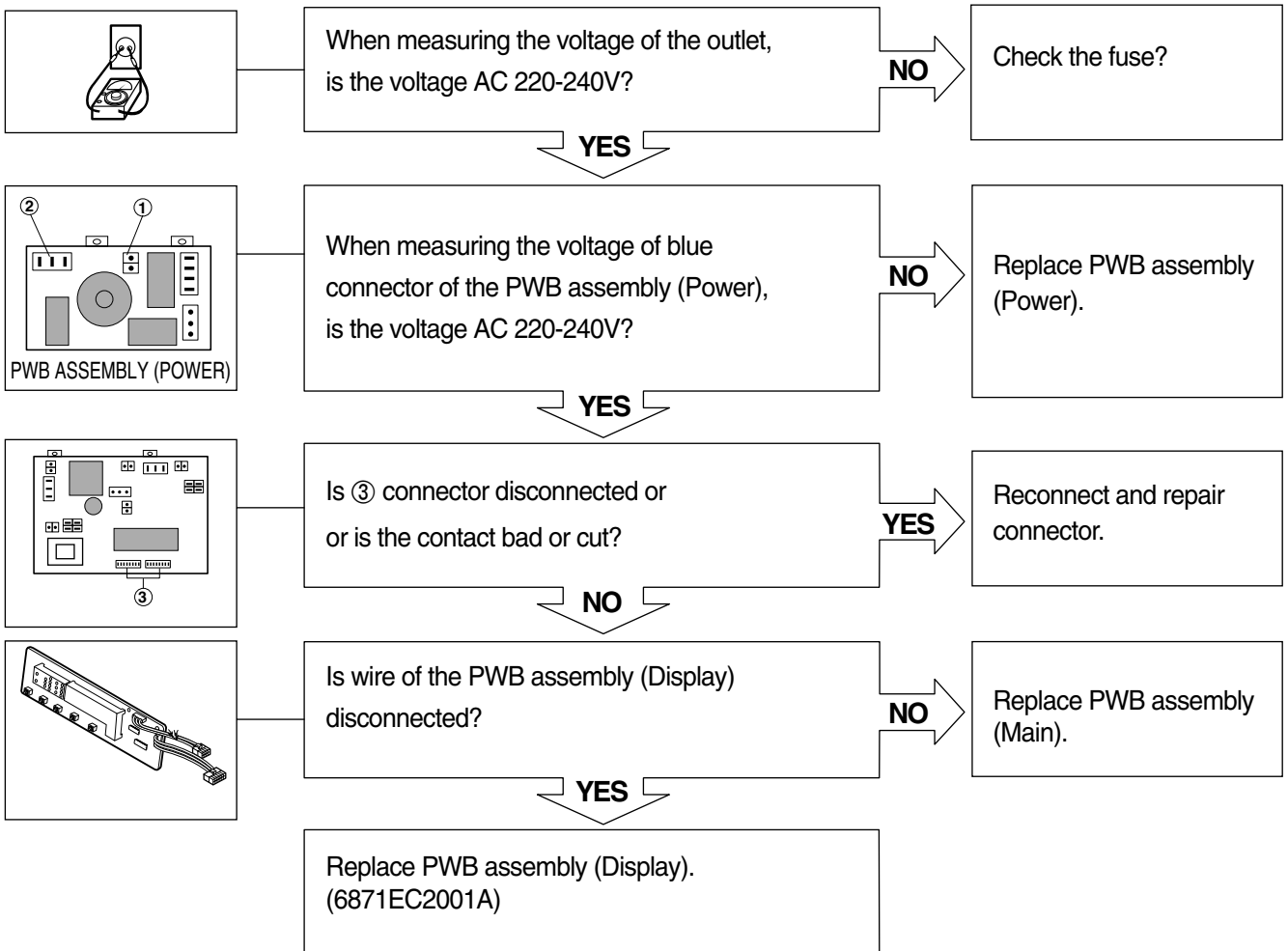

NO WATER SUPPLY

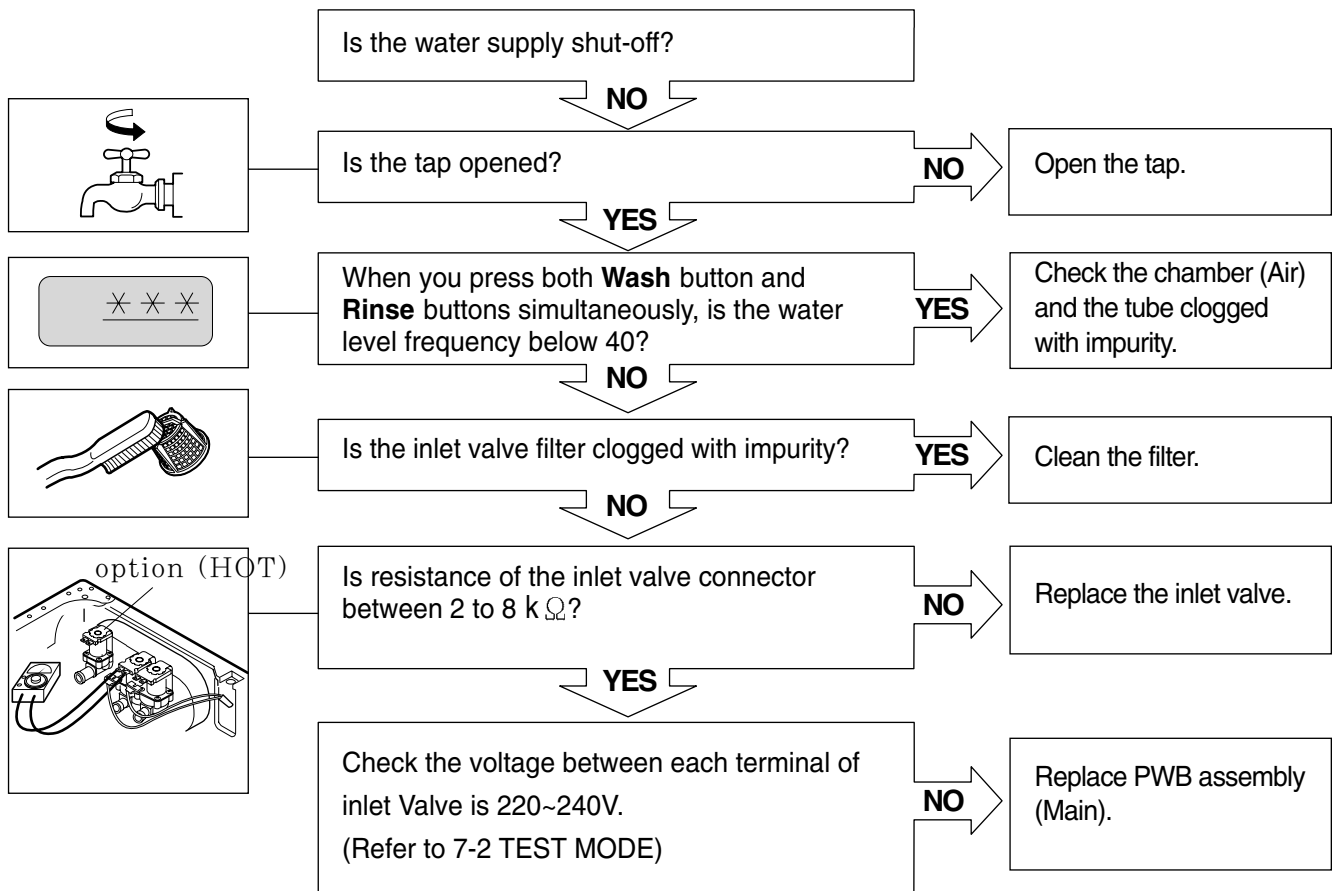

DETERGENT DOES NOT FLOW IN

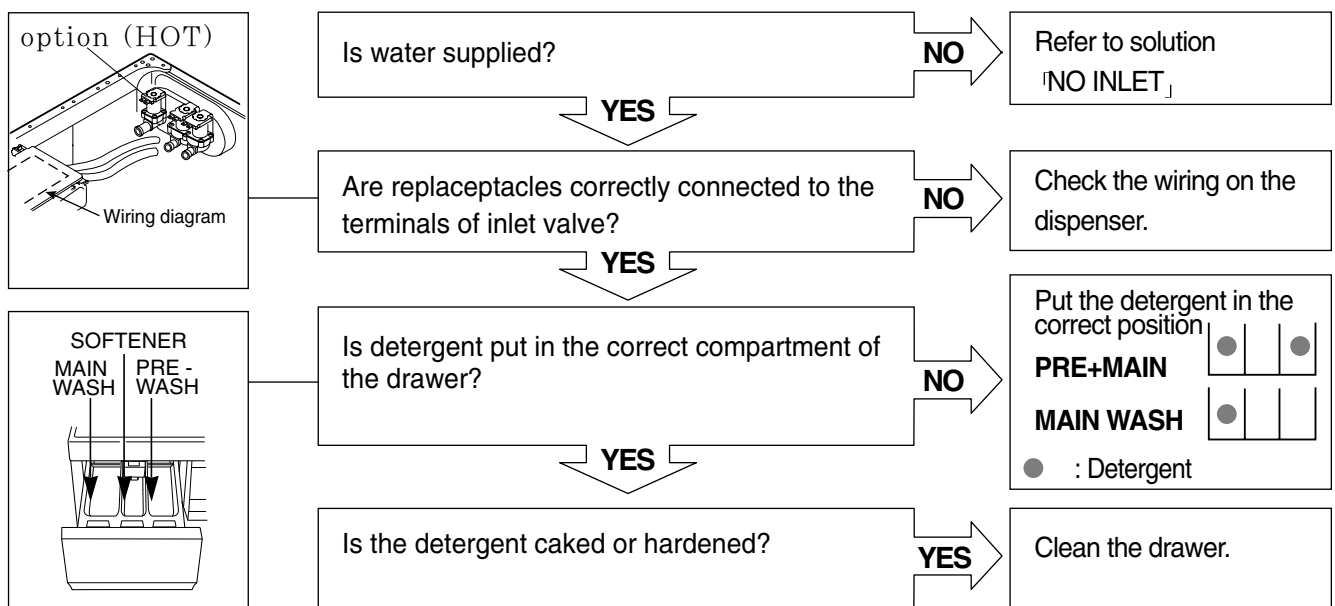

SOFTENER DOES NOT FLOW IN

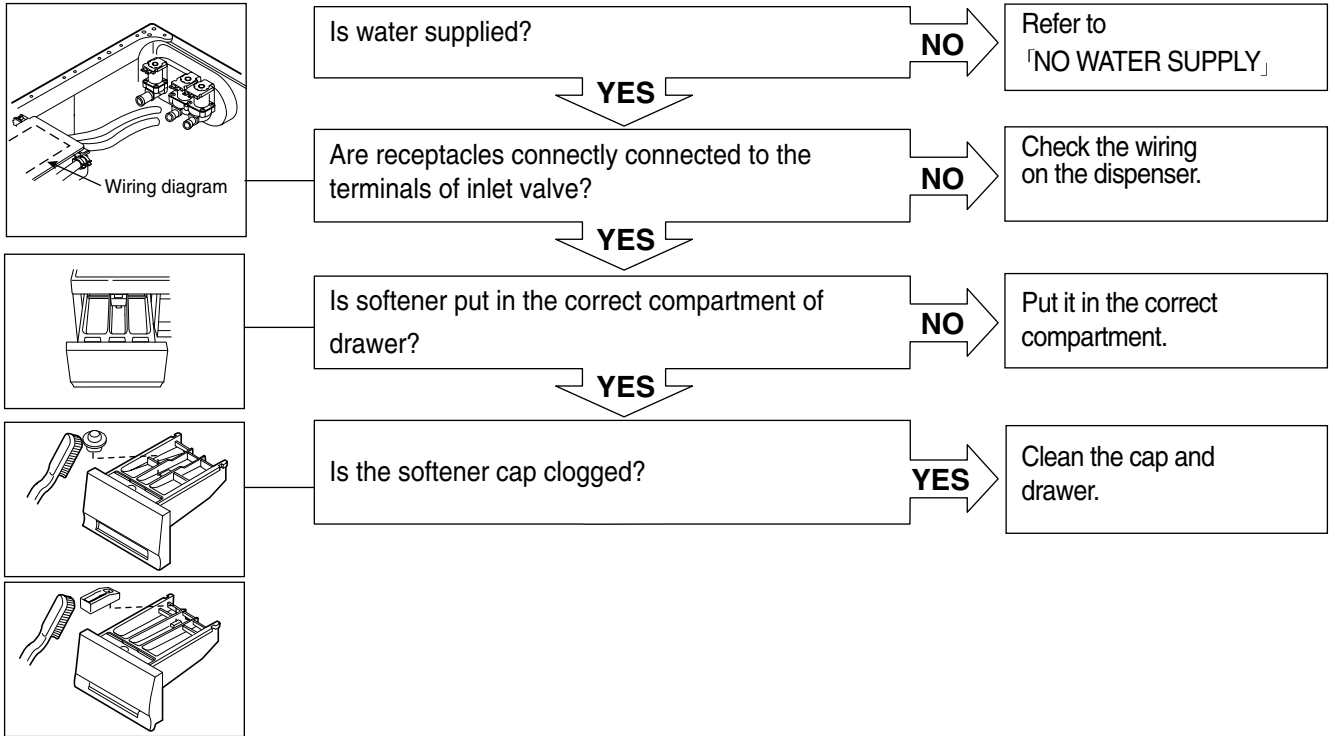

ABNORMAL SOUND

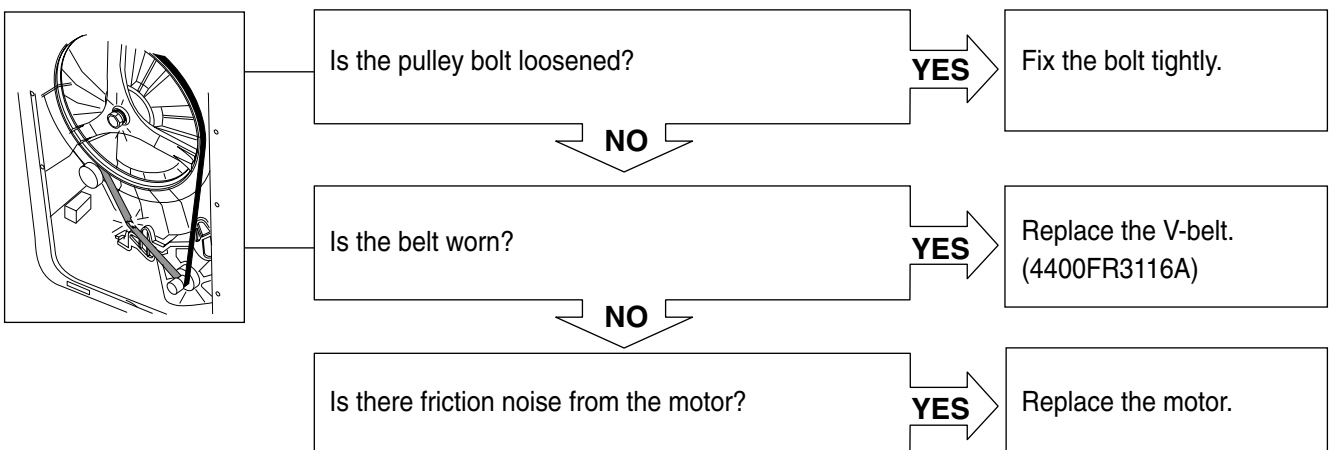

HEATING WITHOUT WATER

■ WD-1223(5)F(H)(B)/WD-1243(5)F(H)(B) / WD-1041(3)F(H)B / WD-102(4)1(5)F(H)B / WD-803(4)0F(H)B

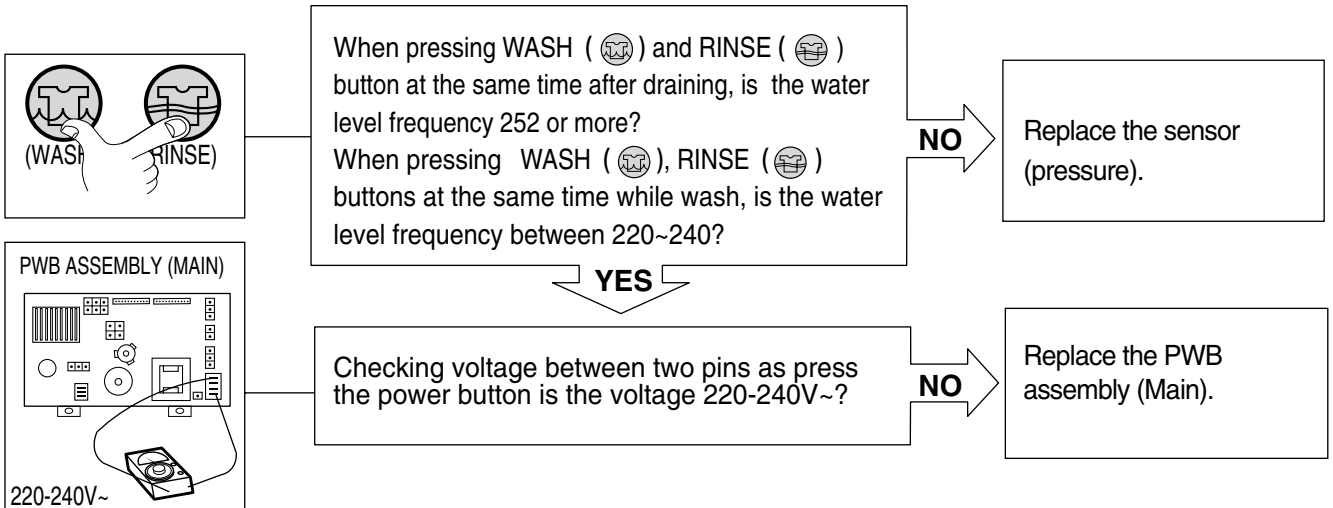

■ WD-803(4)0(W)(F)(H)/WD-102(4)1(5)W(F)(H)/WD-1042F(H)

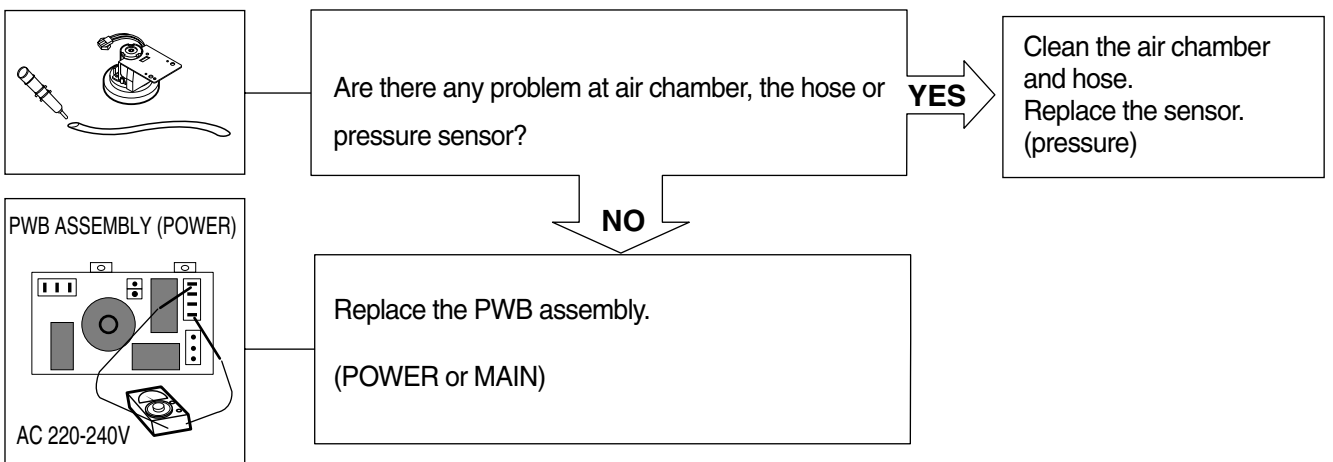

DRAIN MALFUNCTIONING

■ WD-1223(5)F(H)(B)/WD-1243(5)F(H)(B) / WD-1041(3)F(H)B / WD-102(4)1(5)F(H)B / WD-803(4)0F(H)B

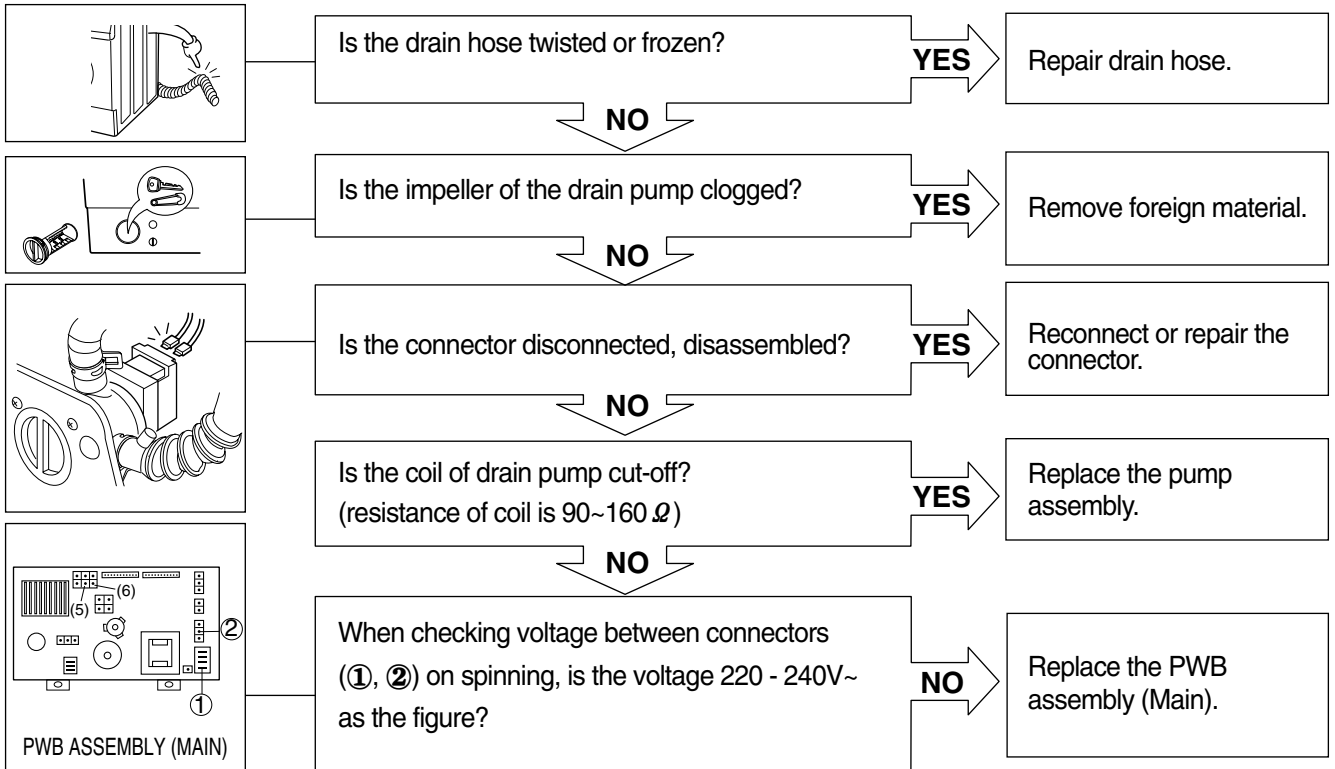

■ WD-803(4)0(W)(F)(H)/WD-102(4)1(5)W(F)(H)/WD-1042F(H)

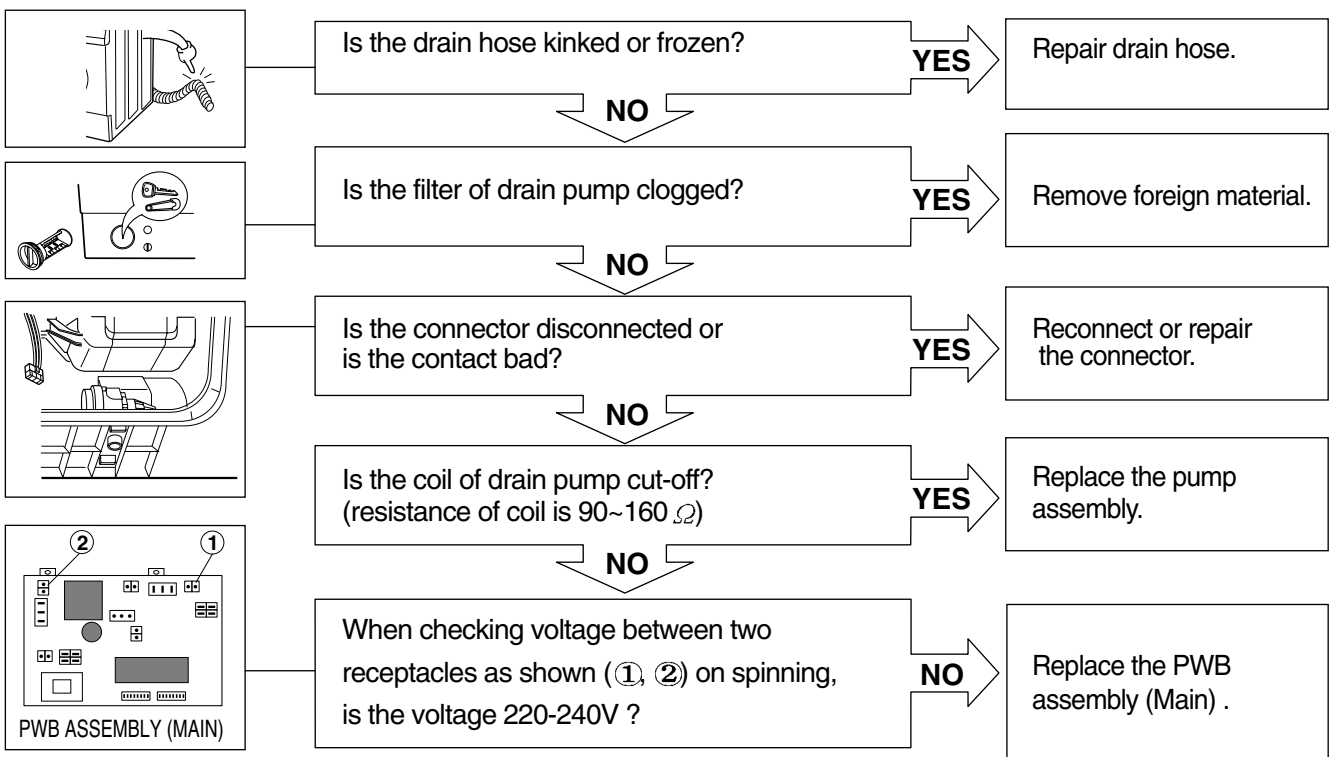

WASH HEATER TROUBLE

■ WD-1223(5)F(H)(B)/WD-1243(5)F(H)(B) / WD-1041(3)F(H)B / WD-102(4)1(5)F(H)B / WD-803(4)0F(H)B

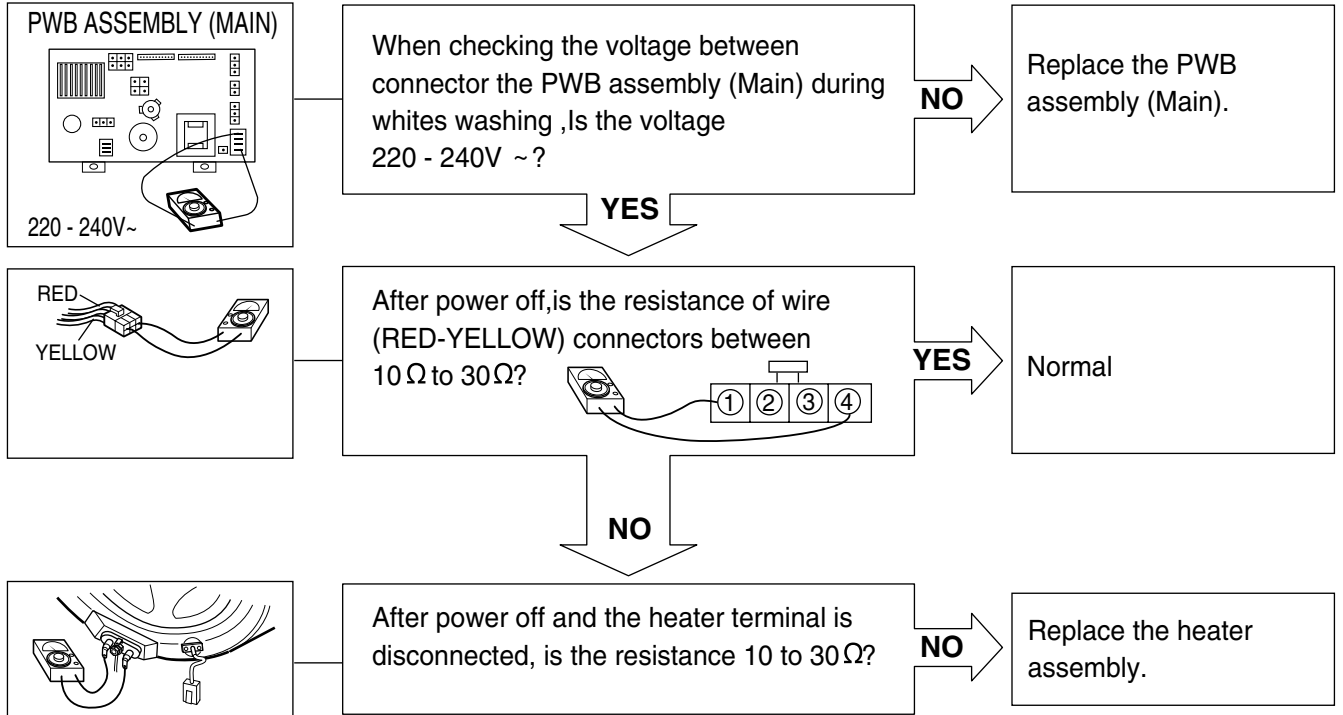

■ WD-803(4)0(W)(F)(H)/WD-102(4)1(5)W(F)(H)/WD-1042F(H)

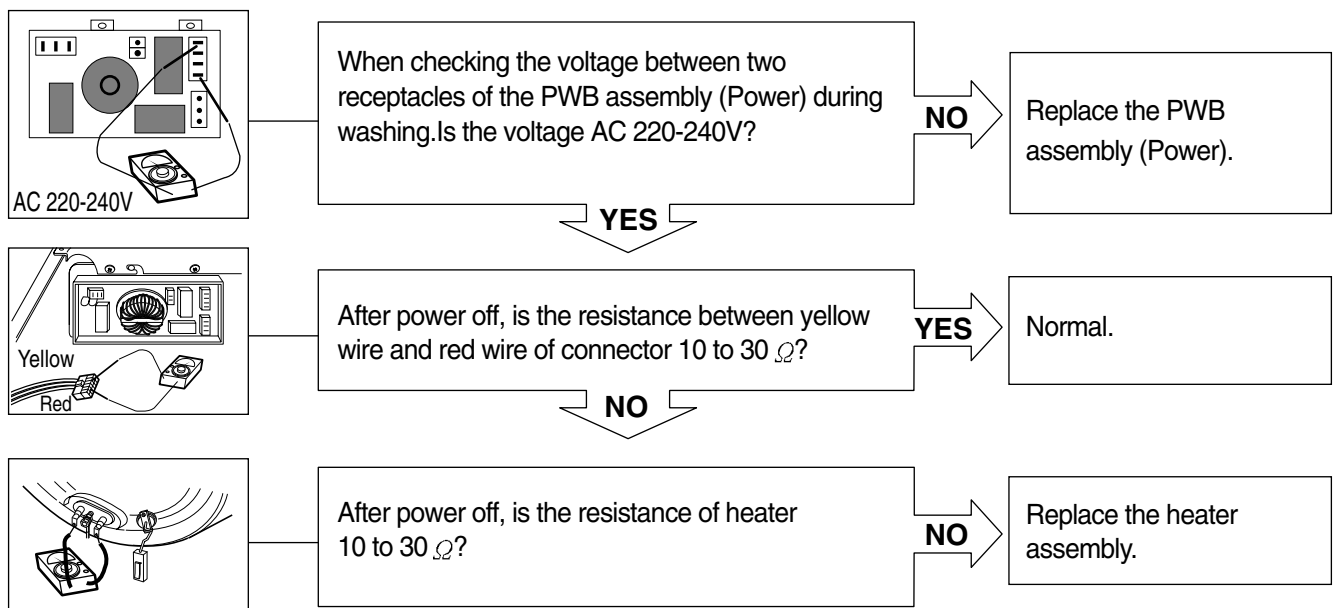

HEATING CONTINUOUSLY ABOVE THE SETTING WATER TEMPERATURE

■ WD-1223(5)F(H)(B)/WD-1243(5)F(H)(B) / WD-1041(3)F(H)B / WD-102(4)1(5)F(H)B / WD-803(4)0F(H)B

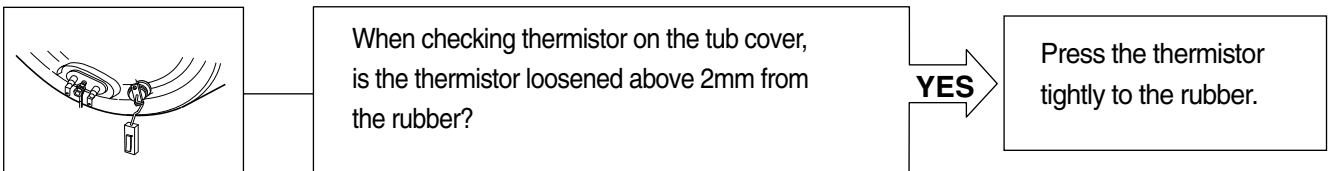
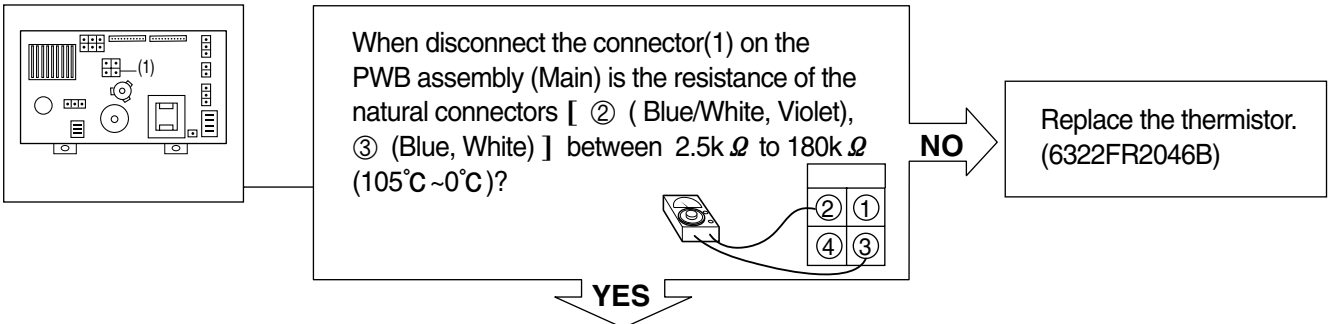

■ WD-803(4)0(W)(F)(H)/WD-102(4)1(5)W(F)(H)/WD-1042F(H)

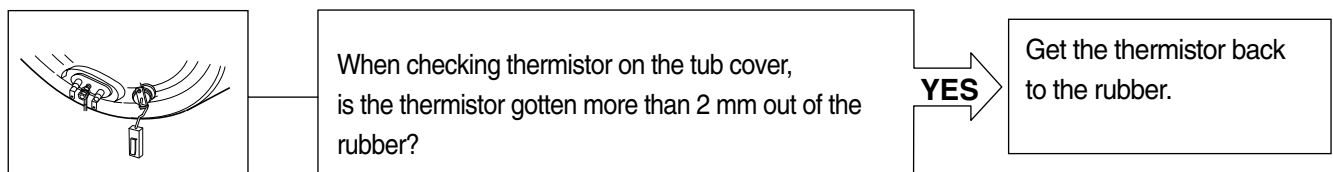
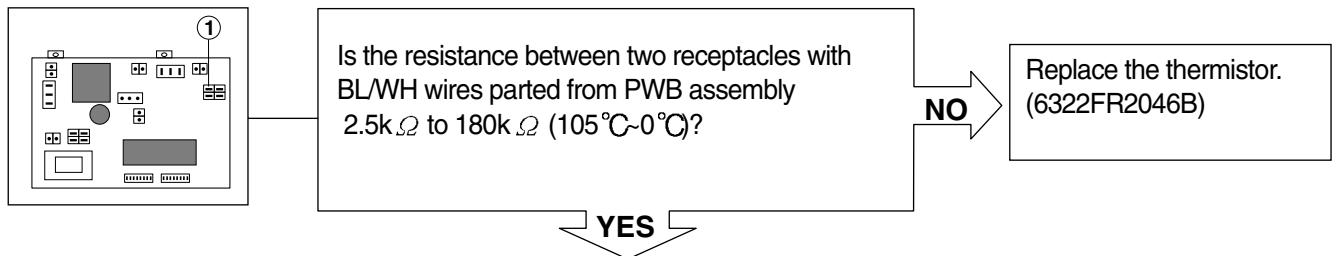

SPIN TROUBLE

■ WD-1223(5)F(H)(B)/WD-1243(5)F(H)(B) / WD-1041(3)F(H)B / WD-102(4)1(5)F(H)B / WD-803(4)0F(H)B

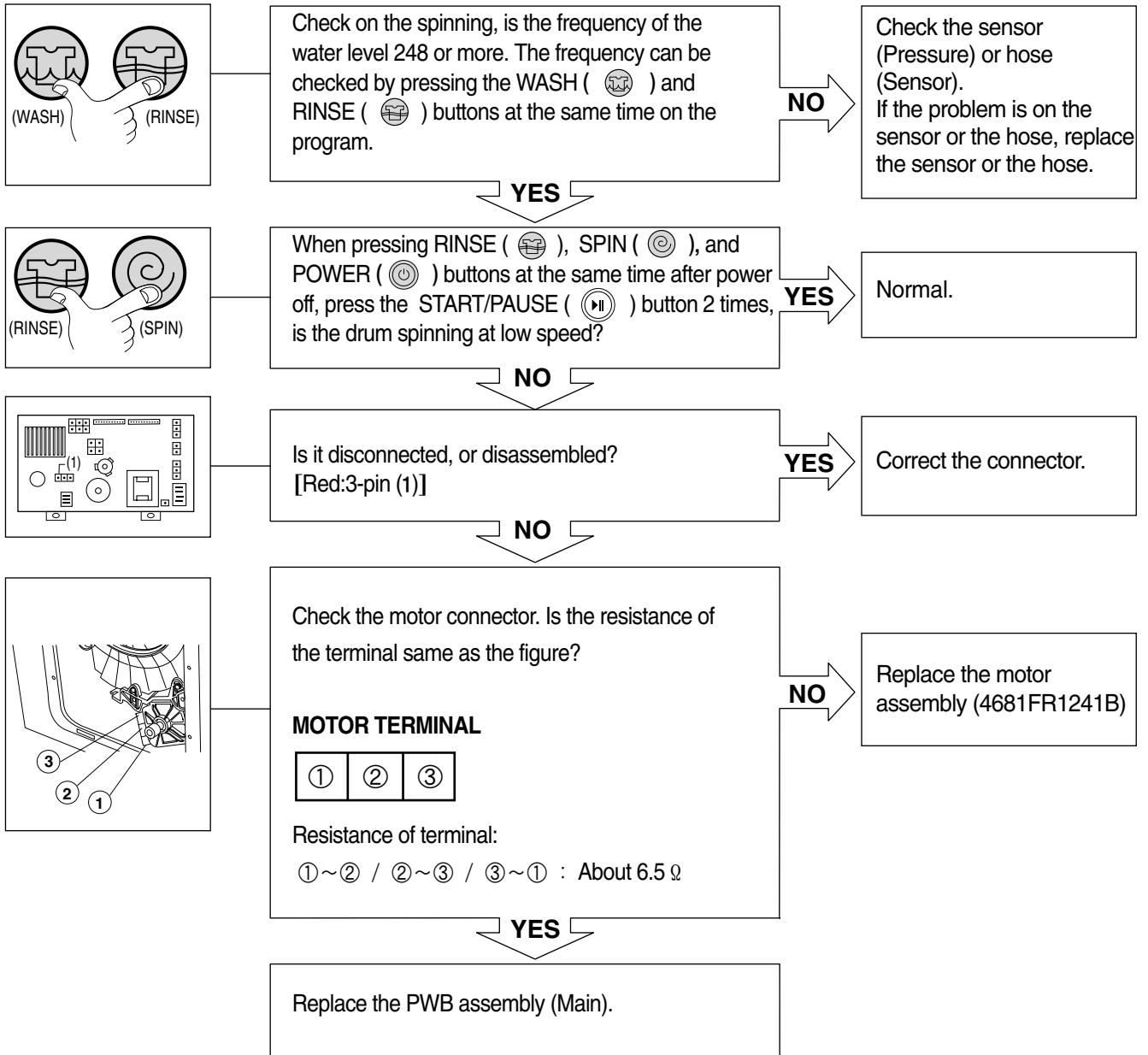

■ WD-803(4)0(W)(F)(H)/WD-102(4)1(5)W(F)(H)/WD-1042F(H)

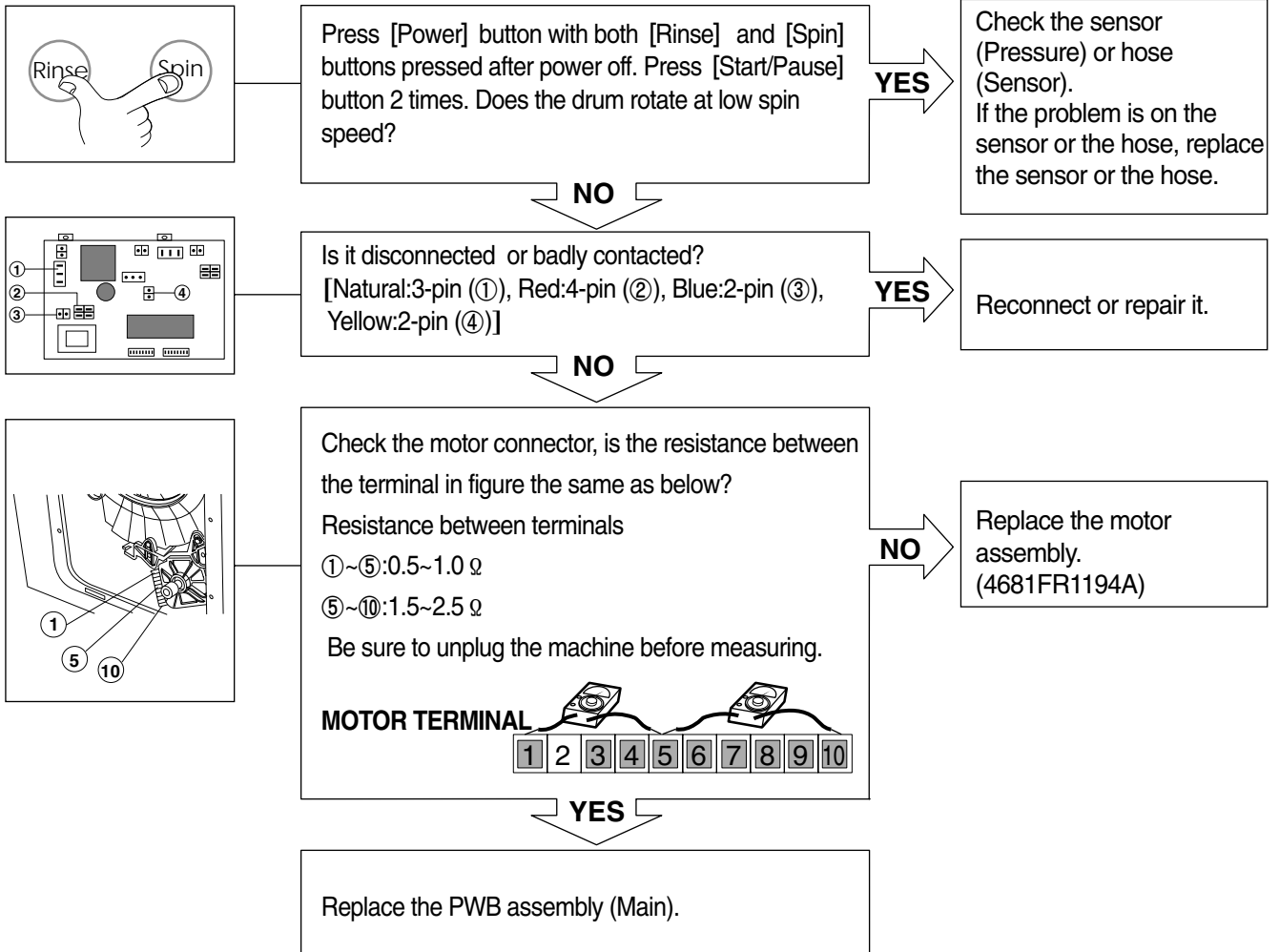

10. DISASSEMBLY INSTRUCTIONS

* Disassemble and repair the parts after pulling out power cord from the outlet

CONTROL PANEL

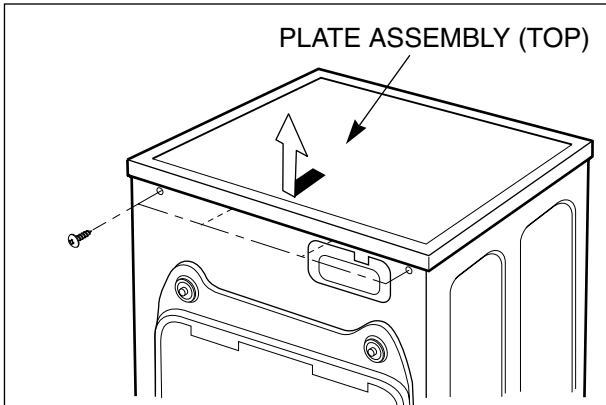

- ① Two screws are unscrewed on the top plate.
- ② The plate assembly (Top) is pulled back and then upward to arrow direction.

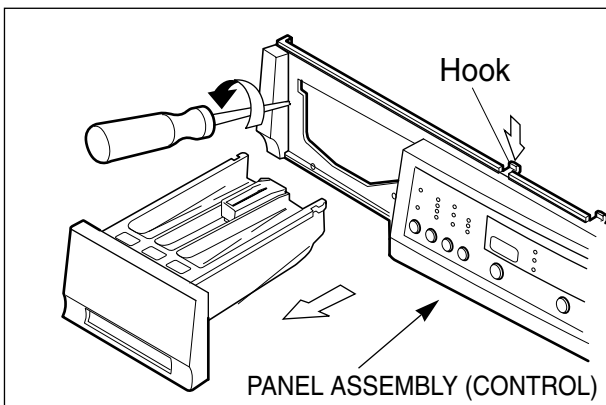

- ① The PWB assembly (Display) connectors are disconnected.
- ② Pull out drawer, three screws are unscrewed.

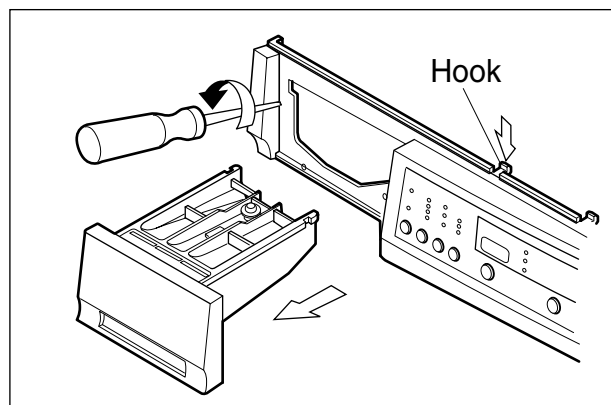

- ③ Push two upper hooks and pull the control panel forward.

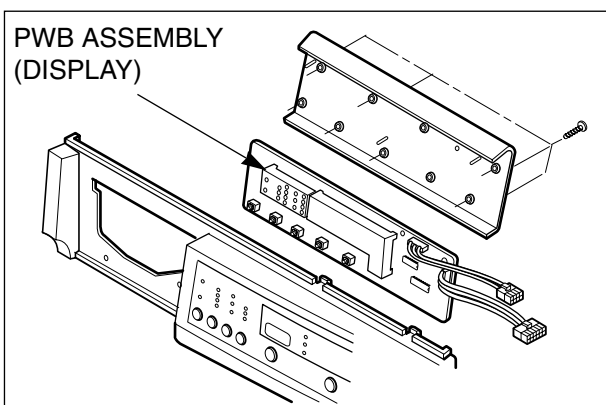

- ① The PWB assembly (Display) is disconnected.
- ② When 9 screws are unscrewed on the PWB insulator and the PWB assembly (Display) is disassembled from the PWB insulator.

DISPENSER ASSEMBLY

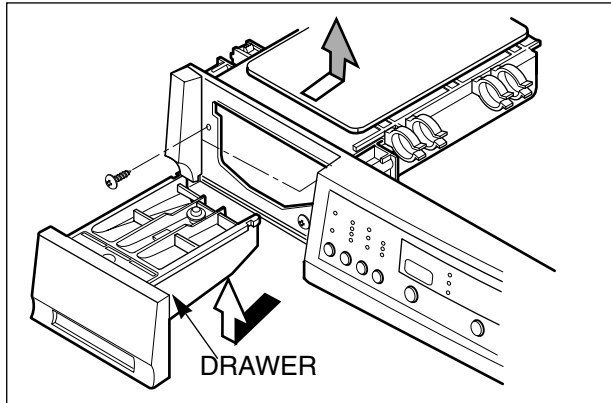
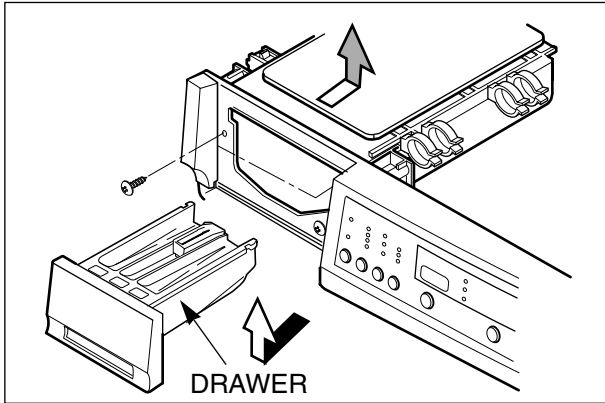

- ① Disassemble the top plate assembly.
- ② Pull the drawer to arrow direction.
- ③ Two screws are unscrewed.

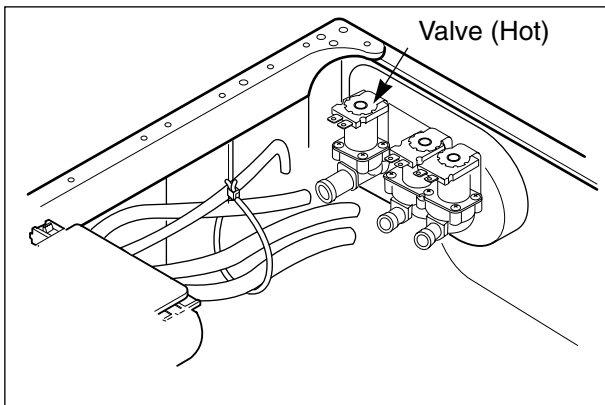

- ① The hose clamps and the hose are disassembled.
- ② The ventilation bellows and the water inlet bellows are disassembled on the tub.

INLET VALVE

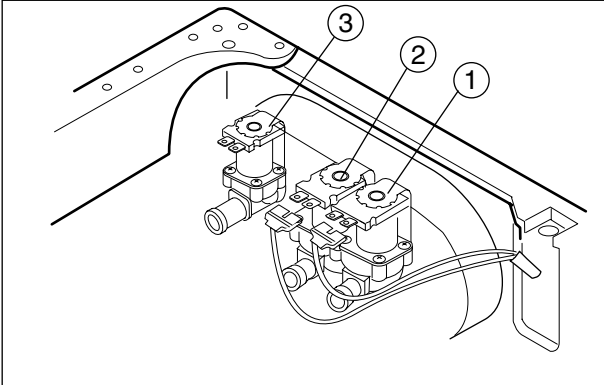

- ① Disconnect the wiring connector.
- ② Unscrew 2 screws from the back.

* When reconnecting the connector

VALVE#1 (MAIN)	White/Black - Black
VALVE#2 (PRE)	Gray/ White - Black

VALVE#3 (HOT)	Blue/Red-Black
---------------	----------------

[WD-1223FH(B)/1225FH(B)/1243FH(B)

WD-1245FH(B)/1041(3)FH(B)

WD-803(4)0(W)(F)H

WD-102(4)1(5)W(F)H/102(4)1(5)FH(B)

WD-1042FH(B)/803(4)0FH(B)]

PWB ASSEMBLY (MAIN)

- WD-1223(5)F(H)(B) / WD-1243(5)F(H)(B)
WD-1041(3)F(H)B / WD-102(4)1(5)F(H)B
WD-803(4)0F(H)B

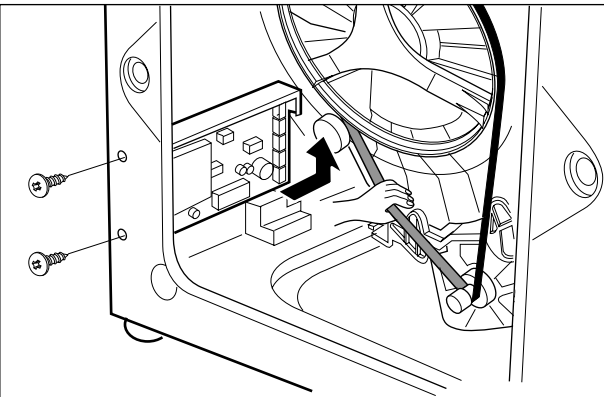

- WD-803(4)0(W)(F)(H)/WD-102(4)1(5)W(F)(H)
WD-1042F(H)

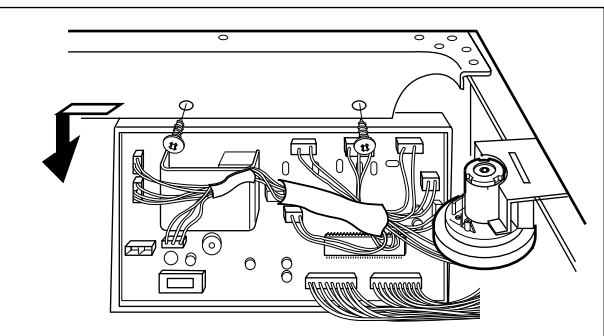

- ① The back cover is removed.
- ② Unscrew 2 screws
- ③ Pull the PWB assembly (Main) as shown.

LOWER COVER

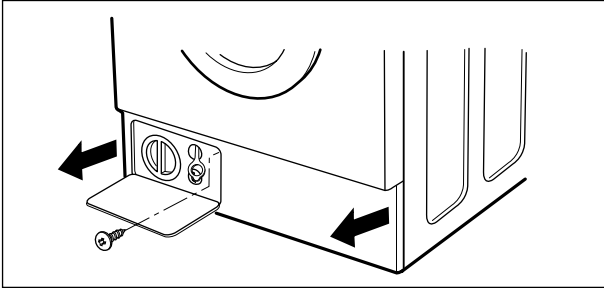

- Open the lower cover cap by using coin and remove the lower cover to arrow direction after screw is unscrewed.

DOOR

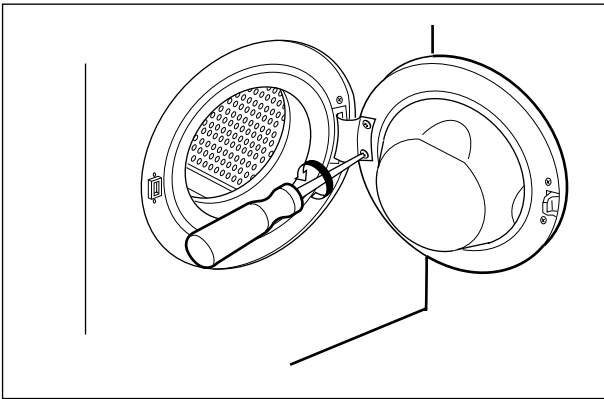

- ※ When the power cord is plugged, the door can be opened by pressing the DOOR OPEN () button.

- ① Open the door completely.
- ② Remove the two screws from the hinge.

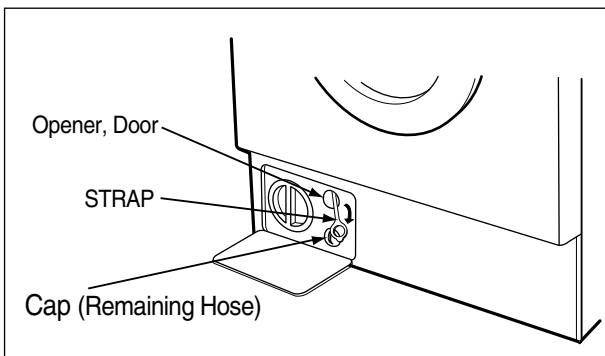

Opening the door in emergency

- ① When you can not the door with the front door button (i.e. power failure) there is an emergency opener on your machine.
- ② To reach this opener you have to open the lower cover cap and pull the opener to open the front door.

ATTENTION!

Do not use this emergency opener during wash.

Removing method of remained water

- ① Rotate the drain plug (remaining hose) to arrow direction.
- ② Pull it out from hose.

※ First, prepare a bucket to put in the remained water

GASKET ASSEMBLY

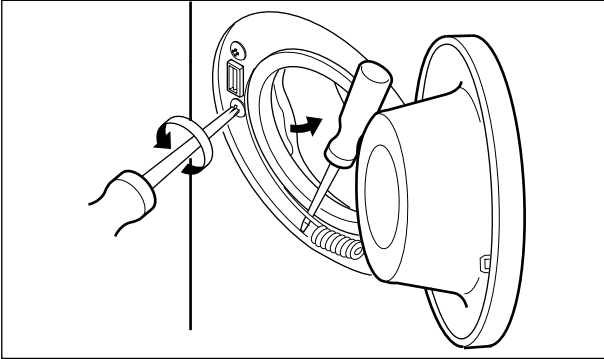

- ① The cabinet gasket clamp is released.
- ② Two screws are unscrewed from the cabinet cover.

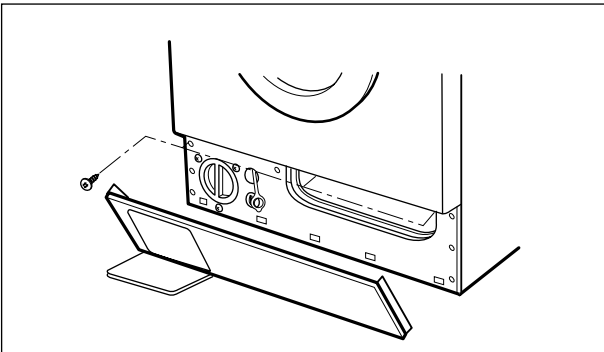

- ① Three screws are unscrewed from the lower cover.
- ② The lower cover is disassembled.

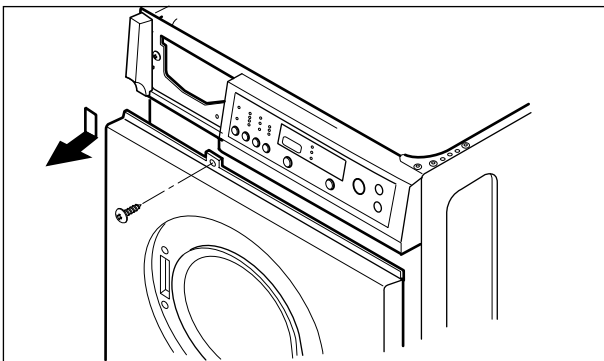

- ① The control panel is removed.
- ② Screw is unscrewed from the cabinet cover.

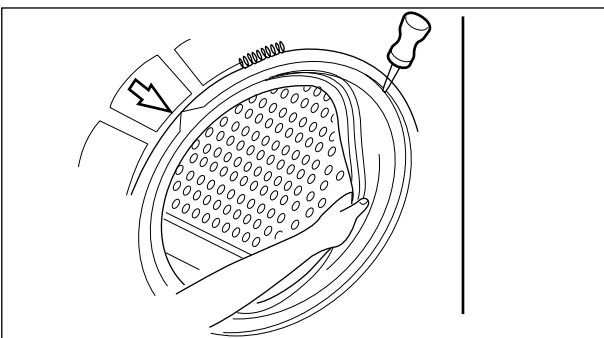

- ① Take apart the tub gasket clamp
 - ② Make sure that the drain hole of the gasket is put beneath when reassembling the gasket.
- ※ Refer to the arrow mark on the tub cover.

PULLEY, MOTOR, DAMPER

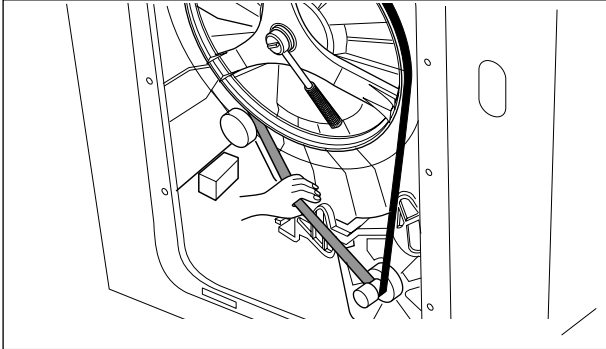

(PULLEY)

- ① The back cover is removed.
- ② The belt is pulled off while turning over the pulley.
- ③ The bolt is unscrewed to the shaft and then the pulley pulled off.

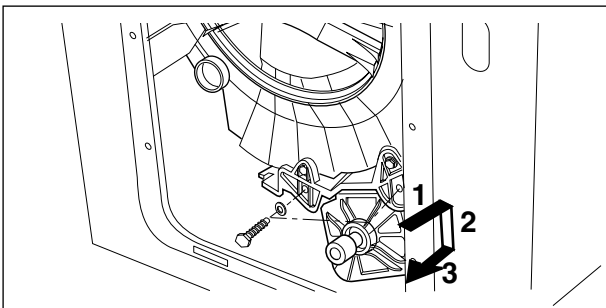

(MOTOR)

- ① Two screws are unscrewed from the bracket (Motor).
- ② The motor is pushed to arrow direction and then it is disassembled.
(When mounting the bushing should be fit the bracket holder <Motor>)

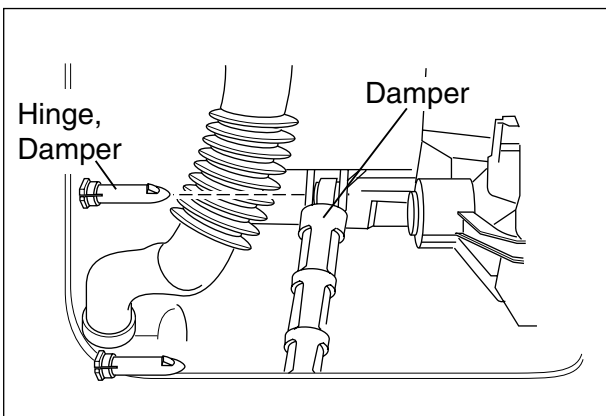

(DAMPER)

- ① Lay the washing machine.
- ② The hinge (Damper) at the tub is pulled off pressing on the snaps at the sharp end.
- ③ The hinge at the base is pulled off.

PUMP

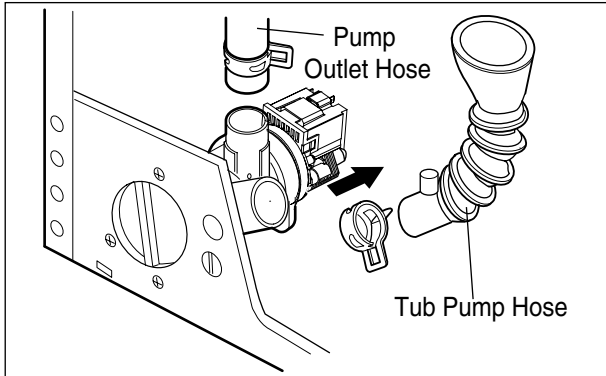

- ① Remove the pump outlet hose.
- ② Remove the tub pump hose.
- ③ The pump connectors are disconnected, the hose is pulled off.
- ④ Three screws are unscrewed.
- ⑤ The pump is disassembled to arrow direction.

HEATER

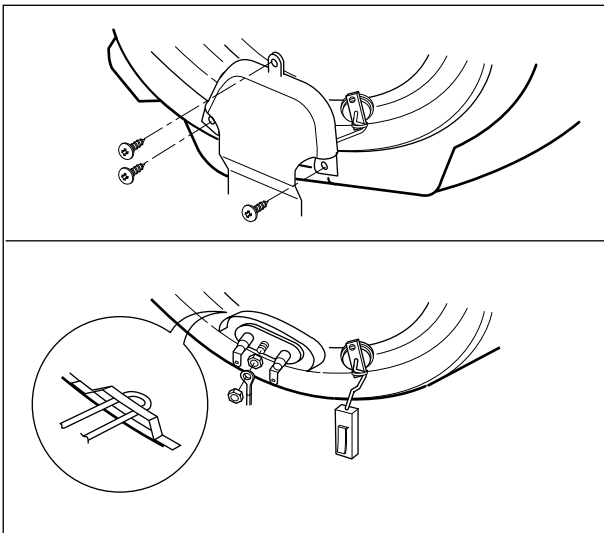

CAUTION

When mounting the heater, the heater should be inserted the heater clip on the bottom of the tub.

THERMISTOR

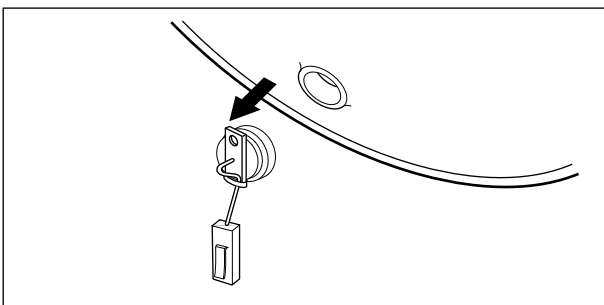

DOOR HINGE ASSEMBLY

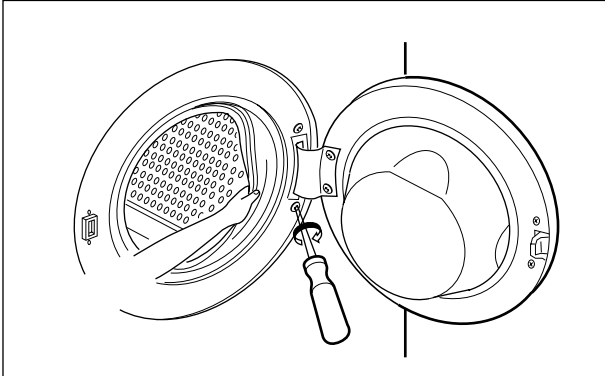

- ① Two screws are unscrewed on the door and the door is disassembled.
- ② The cabinet cover clamp is removed and the gasket is released.
- ③ Two screws are unscrewed on the door hinge.
- ④ The door hinge is disassembled by pressing the door hinge arm inside the cabinet cover.

SWITCH ASSEMBLY, DOOR LOCK

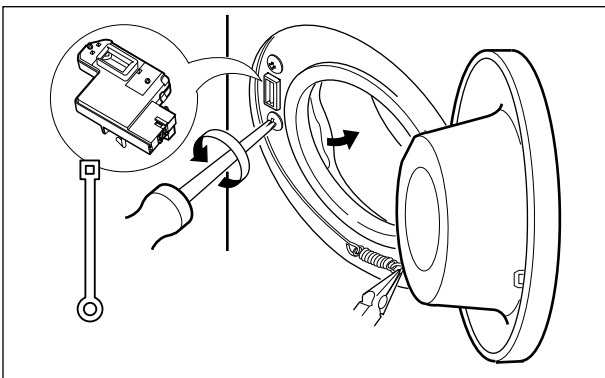

- ① The cabinet cover clamp is removed and the gasket is released.
- ② Two screws are unscrewed.
- ③ The door lock S/W is disconnected from the wiring connector and the strap.

WHEN FOREIGN MATERIAL STACK BETWEEN DRUM AND TUB

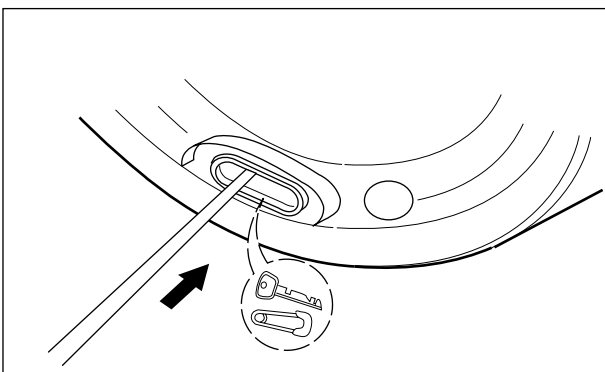

- ① The heater is removed.
- ② The foreign material (wire, coin, etc) is removed by inserting the long bar in the hole.

11. EXPLODED VIEW

11-1. THE EXPLODED VIEW OF CABINET ASSEMBLY

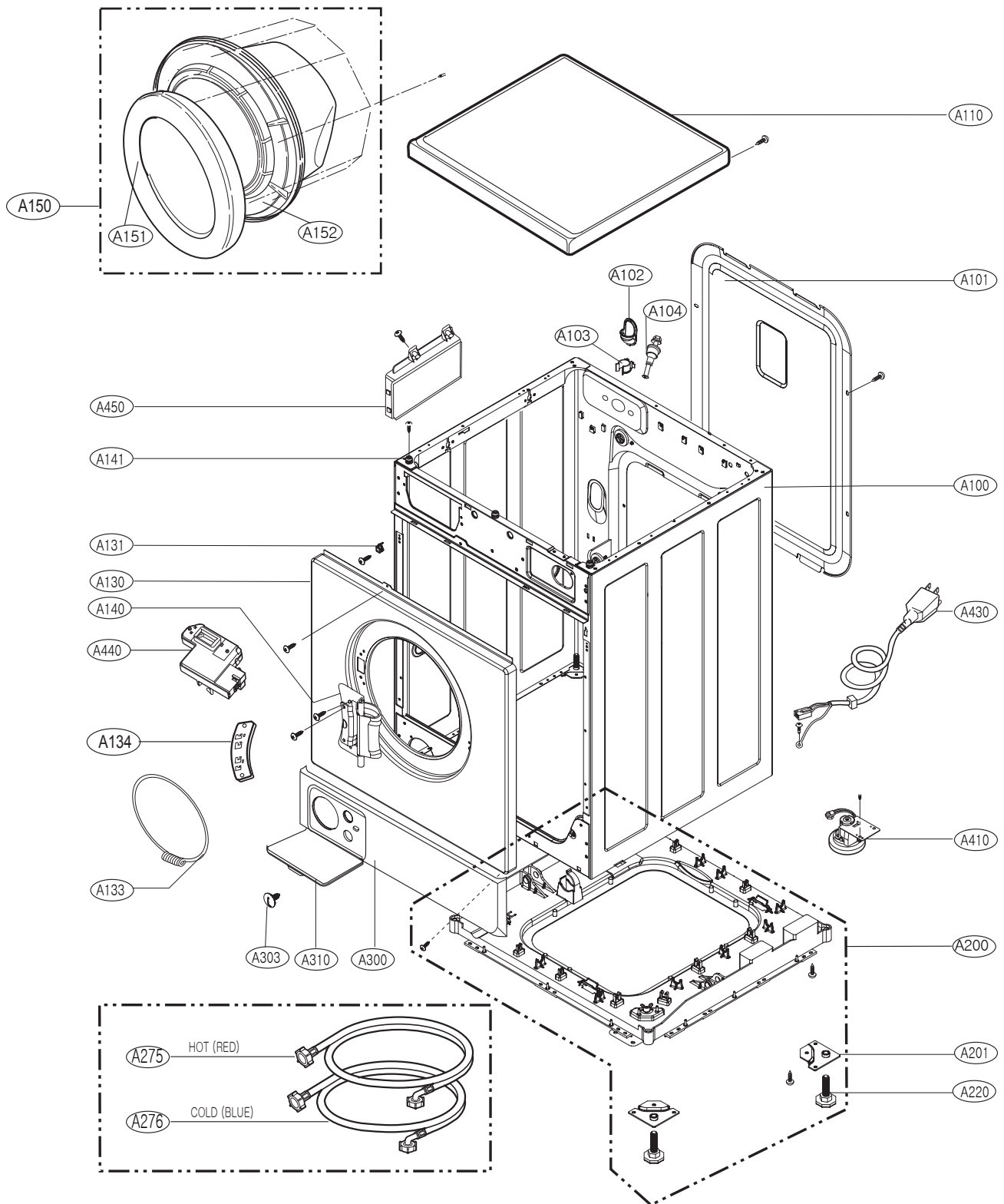

11-2 THE EXPLODED VIEW OF CONTROL PANEL & DISPENSER ASSEMBLY

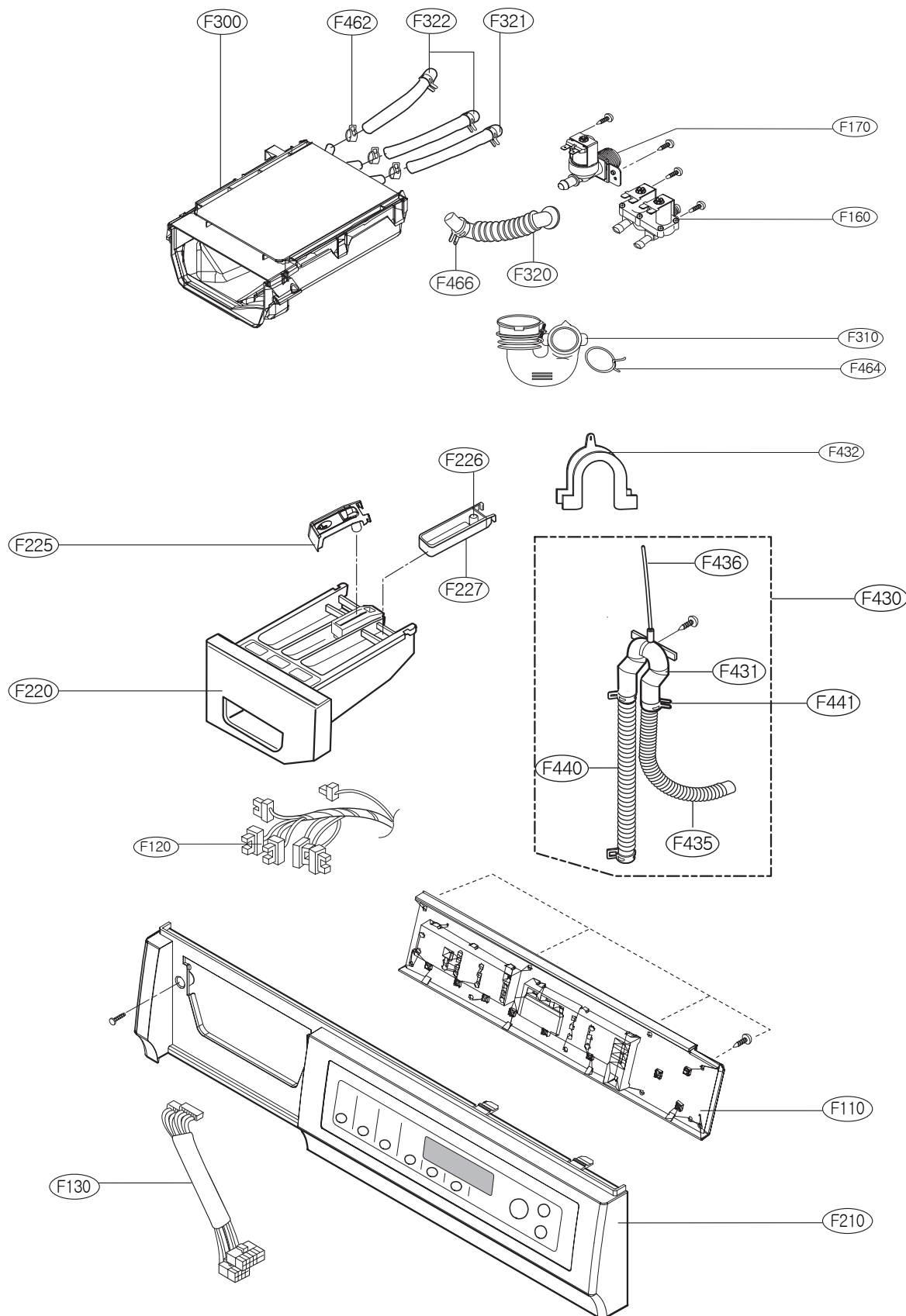

11-3 THE EXPLODED VIEW OF DRUM & TUB ASSEMBLY

