

This Owner's Manual is provided and hosted by [Appliance Factory Parts](#).

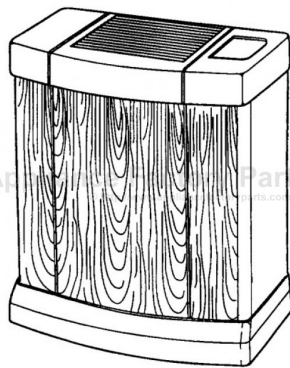

EMERSON HD70020 Owner's Manual

[Shop genuine replacement parts for EMERSON
HD70020](#)



[Find Your EMERSON Humidifier Parts - Select From 160 Models](#)

----- Manual continues below -----

**CAUTION: Read all instructions carefully before installation.
Save this Owner's Manual for future reference.**

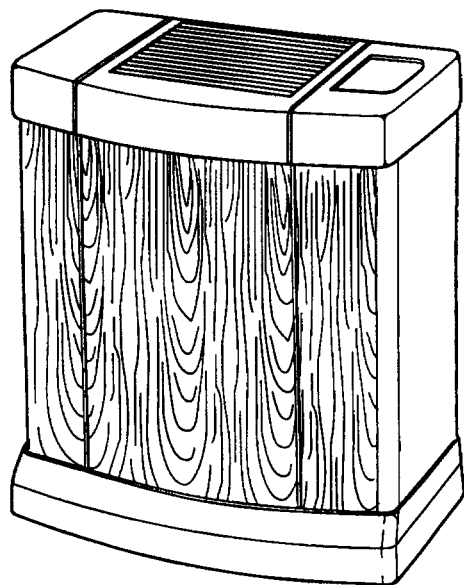

Model Nos. HD7002 1 & HD7005 0

EMERSON®

***MoistAIR™* HD7002 & HD7005
Evaporative Console
Humidifier Owner's Manual**

Limited Warranty

All products covered by this Owner's Manual are warranted against defects in workmanship and materials for one year from the date of sale except for motors, which are warranted for two years. This warranty does not apply to damage from accident, misuse or alteration nor where the connected voltage is more than 5% above the nameplate voltage, nor to equipment improperly installed or wired or maintained in violation of this Owner's Manual. No other written or oral warranty applies. No employee, agent, dealer or other person is authorized to give any warranties on behalf of Emerson Electric.

The customer shall be responsible for all costs incurred in the removal or reinstallation and shipping of the product for repairs. Within the limitations of this warranty, inoperative units should be returned, freight prepaid to the nearest Emerson authorized service center and we will repair or replace, at our option, at no charge to you with return freight paid by Emerson. It is agreed that such repair or replacement is the exclusive remedy available from Emerson Electric Co. and that **Emerson Is Not Responsible For Damages Of Any Kind, Including Incidental And Consequential Damage**. Some states do not allow the exclusion or limitation of incidental or consequential damages, so the above exclusion or limitation may not apply to you.

The warranty gives you specific legal rights, and you may also have other rights which vary from state to state or province to province.

Sales receipt required as proof of purchase for warranty claims.

GENERAL SAFETY INSTRUCTIONS

Safety Signal Words

DANGER: means if the safety information is not followed, someone **will** be seriously injured or killed.

WARNING: means if the safety information is not followed, someone **could** be seriously injured or killed.

CAUTION: means if the safety information is not followed, someone **may** be seriously injured or killed.

1. To reduce the risk of fire or shock hazard, plug humidifier directly into a 120V, A.C. electrical outlet. Do not use extension cords.
2. Keep the electric cord out of traffic areas. To reduce the risk of fire hazard, never put the electric cord under rugs, near heat registers, radiators, stoves or heaters.
3. Always unplug the humidifier before moving it, before cleaning, or whenever the humidifier is not in service.

4. Keep the humidifier clean.
5. Do not put foreign objects inside the humidifier.
6. Never use your humidifier while any part is missing or damaged in any manner.
7. To reduce the risk of electrical hazard or damage to humidifier, do not tilt, jolt or tip humidifier while unit is running.
8. To reduce the risk of damage to humidifier, unplug humidifier, when water bottle is empty or when the humidifier is not in use.
9. To reduce the risk of accidental electrical shock, do not touch the cord or controls with wet hands.
10. Note the warning label shown.

WARNING: To reduce risk of fire, electric shock, or injury always unplug before filling, servicing or cleaning.

Know Your Humidifier

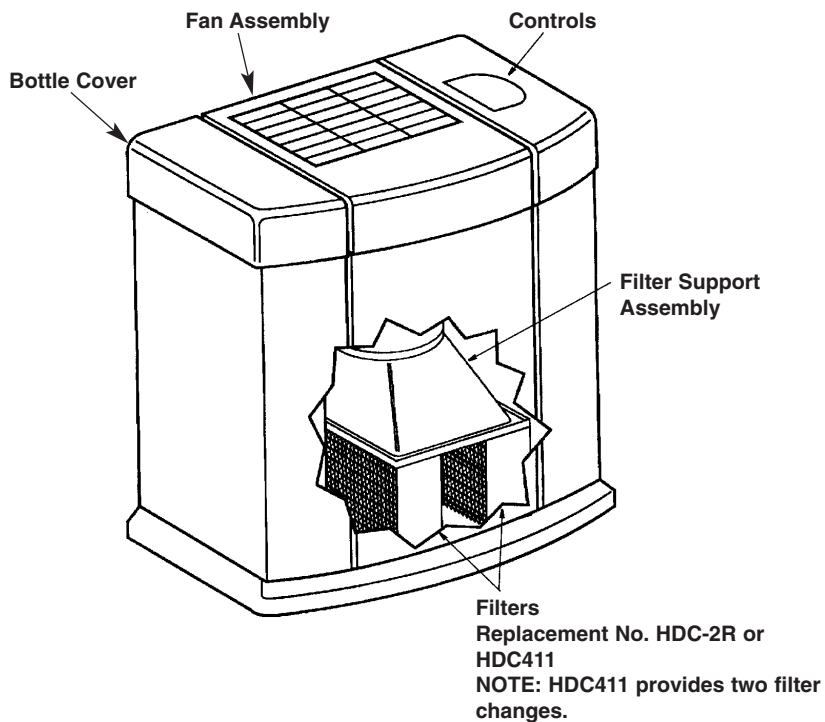

| Description | HD7002 & HD7005 |
|------------------------|-----------------|
| Gallon Output / 24 hrs | 7 |
| Litre Output / 24 hrs. | 26.5 |
| Capacity of Bottle | 2.5 Gallons |
| Capacity of Bottle | 9.4 Litres |
| * Sq. Ft. Coverage | 1500 |
| Fan Speeds | 3 |
| Number of Filters | 2 |
| Fill Light | Yes |
| Auto Humidistat | Yes |
| Auto Shut Off | Yes |
| Controls | Rotary |
| CUL Listed | Yes |
| Volts | 120 A.C. |
| Hertz | 60 |
| Amps | 1.14 |
| Watts | 65 |

* Based on an area with average insulation and an 8-foot ceiling height.

Humidifier Operations

Your new Emerson humidifier is designed to satisfy home humidity requirements through the principle of evaporation of water into the air.

After water is added to the bottle and positioned in the humidifier, the filters begin to soak up the water and become totally saturated in approximately 30 minutes. Air is drawn in from the rear of the humidifier and through the filters by means of one circulation fan. As air passes through the filters, moisture is absorbed into the air and then released through the top of the humidifier. This moist air is released in the form of vapor. No water droplets will enter the home. All evaporation into the air takes place in the humidifier, which means that the residue left by evaporating water is not passed into the home, but remains in the filter.

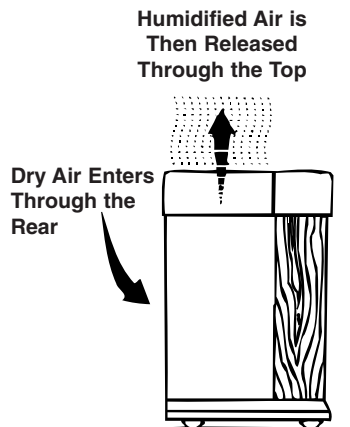

CAUTION: Use only liquid EPA Registered Bacteriostat available from your local retail store or call (800) 654-3545 to order. Under no circumstances should you use water treatment products for Roto belt or Ultrasonic humidifiers.

CAUTION: Keep your humidifier clean. While humidifiers do not cause colds, some studies suggest that dirty humidifiers can cause cold-like symptoms in some people. To avoid this, clean your humidifier weekly with cleaners specifically recommended for evaporative humidifiers.

Assembly

Your new Emerson *MoistAIR* humidifier is completely assembled for you to use.

Follow the instructions of this owner's manual for proper usage.

Electrical Hook-Up

Locate nearest 120V A.C. wall socket in the location desired, preferably on inside wall. Plug in the electrical cord.

install the proper outlet. Do not change the plug in any way.

WARNING: To reduce the risk of fire or shock hazard, do not use extension cords. Humidifier should be plugged directly into a 120V A.C. outlet.

To reduce the risk of electrical shock, this humidifier has a polarized plug (one blade is wider than the other). This plug will fit in a polarized outlet only one way. If the plug does not fit fully in the outlet, reverse plug. If it still does not fit, contact a qualified electrician to

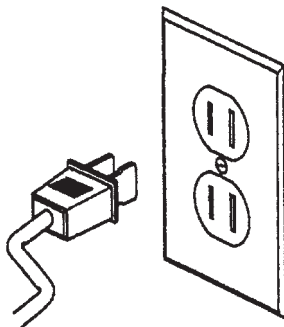

Location Instructions

WARNING: For your own safety, do not use humidifier if any parts are damaged or missing.

1. Place humidifier on a flat level surface in area of house where most humidity is needed, or an area which would likely result in moist air being circulated throughout the house, such as near a cold air return. Placing the unit level is very important if the humidifier is located on carpeting.

Moist air (humidity) produced will disperse into the whole house, but area closest to the unit will have the highest humidity. If the unit is positioned close to a window, condensation may form on the window pane. If this is not acceptable, the unit should be repositioned in another location.

NOTE: Due to release of cool, moist air from humidifier, it is best to direct air away from home thermostat and hot air registers. It is best to position humidifier

next to an inside wall. Hot air registers and cold air from outside walls can affect the efficiencies of the controls. Unit should not be placed where warm air from a hot air register blows directly on unit.

2. The humidifier should be positioned with the back (cord exit side), at least 2 inches away from the wall. Air needs to enter through louvers in the rear panel in order for the humidifier to operate at peak efficiency.

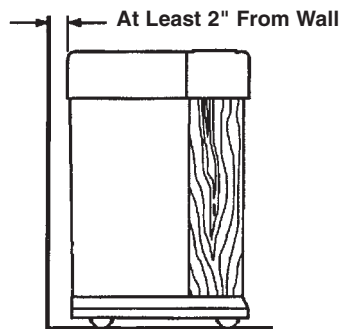

Water Fill

WARNING: To reduce the risk of shock, always unplug humidifier before cleaning or servicing.

WARNING: To reduce the risk of fire or shock hazard, do not pour or spill water into control or motor area. If controls get wet, let them dry completely and have unit checked by an authorized service personnel before plugging in.

This humidifier is designed for use with the water bottle located under the bottle cover to the left of the fan assembly. The unit should be positioned where it will be operating.

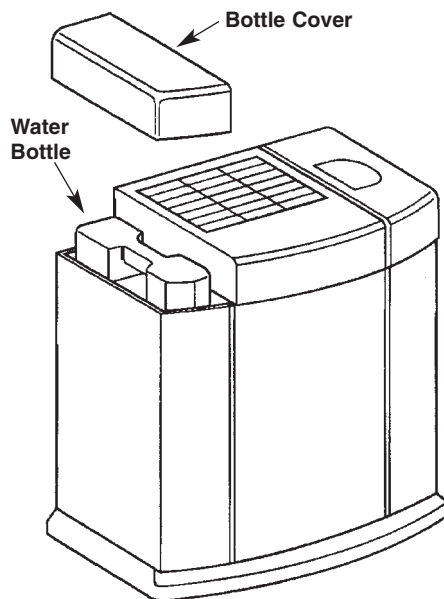

Water Fill (continued)

To fill this humidifier, close the control cover and remove the bottle cover. To remove the water bottle, lift the bottle straight up and out of the cabinet.

The water bottle is designed with an "E-Z-Fill Side-Cap". Remove the "E-Z-Fill Side-Cap" on the side of the water bottle by twisting counterclockwise.

Place the opening of the water bottle under a water faucet (the bottle should fit under a four-inch clearance faucet). Fill the water bottle. Use only clear cold water. Solid debris could make the valve leak.

Install the fill cap by twisting clockwise. Hand tighten only.

Check for possible leaks by performing the following:

1. Grasp bottle handle and hold the bottle upright over sink.
2. Press up on valve cap plunger for about one second to let out a little water.
3. Release the plunger.
4. Listen for air bubbles. Look for leaks around fill cap.
5. If you hear air bubbles or see leaks, retighten cap and check for leaks again.

NOTE: If either the fill cap or the valve cap leaks, water may overflow and leak out the rear vents of the cabinet.

Wipe off excess water from the bottle.

Position the water bottle back into the unit. Grasp the water bottle handle, and lower into the cabinet. For proper operation, the "E-Z-Fill Side-Cap" must be facing the center of the cabinet. When positioned properly, the plunger will open and water will flow into the cabinet. The water level will automatically remain at approximately 1" until the bottle is empty. The unit is now ready for operation.

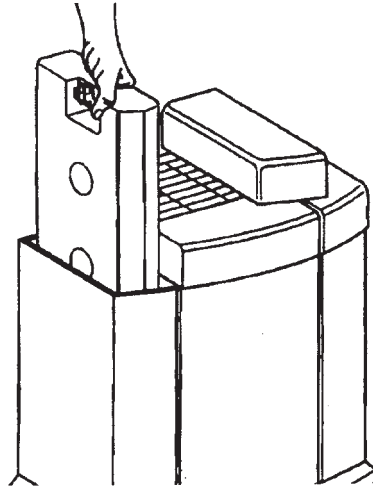
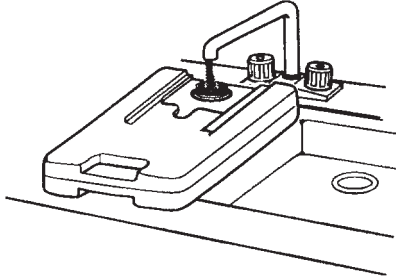
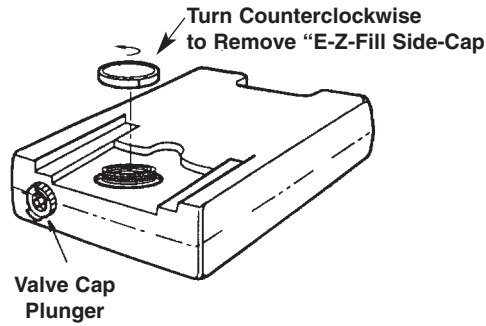

Operating Humidifier Controls

The operating controls of your Emerson evaporative humidifier are located on the top right of the humidifier. The controls are found under the smoked cover

Lift the control cover by placing your finger in the round cutout and lifting. The cover will stay open. Now you can clearly see the control area. Familiarize yourself with the controls and their functions as described below.

Humidity Control:

Adjust the amount of humidity depending on your needs. The humidifier will turn on and off as required to maintain level of humidity selected. A medium setting (midway between) is recommended, but there are times when a low or high amount of humidity may be preferred. For constant operation of humidifier, rotating knob all the way clockwise allows for the maximum amount of humidity to be evaporated into the air continuously.

IMPORTANT: Water damage may result if condensation starts to form on windows or walls. Humidity Control setting should be lowered until condensation no longer forms.

Air Flow (Speed) Control

The unit is adjusted from OFF " " to high " " with a three speed rotary control.





The higher the air flow speed, the more water is evaporated and released into the air. Low speed " " is the quietest and is provided for conditions that may not require as high an evaporation rate.

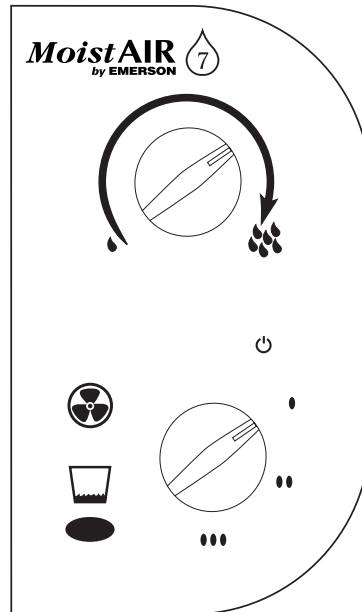

Fill Light

When the unit has a small amount of water left in it, the fill light will come on and the unit will automatically shut off.



Using Your Humidifier

1. Be sure unit is full of water and plugged in.
2. Set air flow control  to desired fan speed.
3. Set Humidity Control  to medium position (halfway between  and ).
4. If humidifier stops running and the Fill Light  is not illuminated, the humidity level is at the normal requirements for that setting or it is adjusting to the home conditions. The table below shows relative humidity percentages which are recommended at various outdoor temperatures. The figure below shows approximate relative humidity percentages which correspond to the various settings of the Humidity Control

NOTE: Humidifier should operate with humidity control on the recommended medium setting (midway between  and ). If it does not, the humidity is at a relatively high level. To test the unit under this condition, turn Humidity Control all the way to clockwise and unit should begin to operate. After the unit has been tested, set Humidity Control to medium or desired level.

Allow 24 hours for humidifier to adjust.

If humidity level in home is sufficient, the humidifier will only operate with Humidity control set on or near  position.

IMPORTANT: Water damage may result if condensation starts to form on windows or walls. HUMIDITY control setting should be lowered until condensation no longer forms.

| When Outdoor Temperature is: | Recommended Indoor Relative Humidity is: |
|------------------------------|--|
| -10°F | 20% |
| 0°F | 25% |
| 10°F | 30% |
| 20°F & above | 35% |

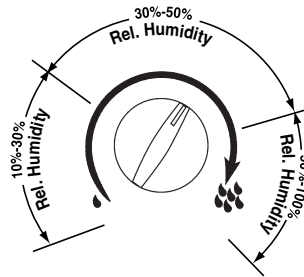

RELATIVE HUMIDITY

Operating Tips for Best Performance

1. Position the humidifier at least 2 inches from any wall and away from any heat registers.
2. Do not restrict airflow from entering or exiting the humidifier.
3. Use liquid EPA-approved bacteriostat to retard bacteria growth that may cause odors and may be harmful to your health.
4. Regular cleaning as instructed in "Cleaning Your Humidifier" section of this manual is recommended.
5. Replace the evaporative wicking filters at least once per humidification season or more depending on water conditions in your area.

Replacement and Care of Filters

WARNING: To reduce the risk of shock or injury from moving parts, always unplug humidifier before removing or replacing any parts.

CAUTION: To help retard bacteria growth and keep maximum efficiency, the filters should be replaced at least once a season, or more often under hard water conditions. Use only Emerson HDC-2R or HDC411 replacement filters.

NOTE: HDC411 provides two complete filter changes.

All filters may be rinsed in clear water only. Take care not to damage paper.

To replace the evaporative wicking filter in your Emerson humidifier, follow the instructions below:

1. Unplug humidifier, and proceed to clean.

Before removing the filters, we recommend moving the humidifier to an area where floor coverings are not susceptible to water damage, i.e. kitchen or bath areas.

2. To remove parts:

Remove the water bottle cover. Lift the fan assembly and set aside on a clean flat surface. Remove water bottle. Lift and remove the filter housing from the cabinet and set to the side. The paper filters are now accessible.

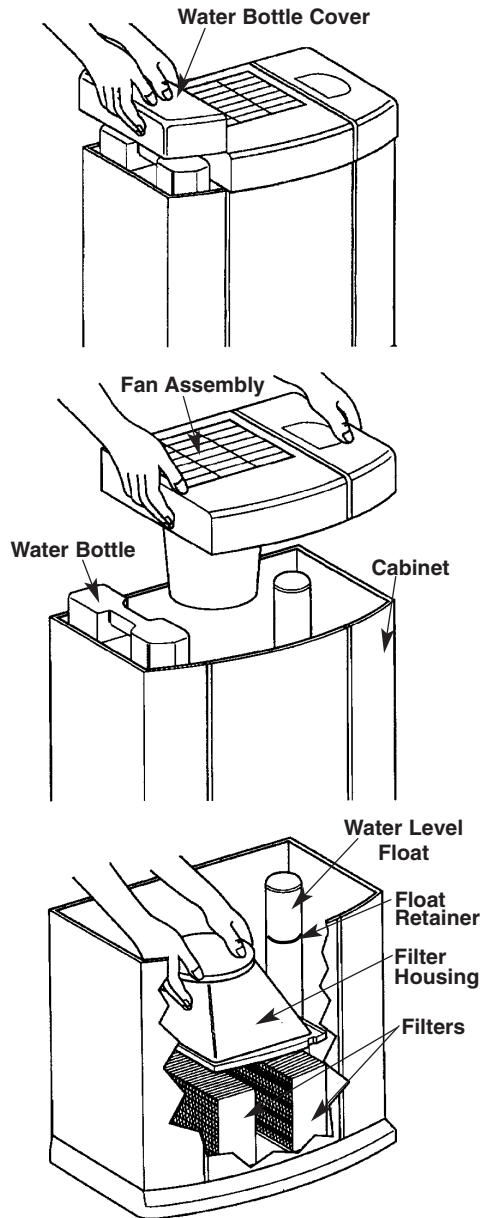

Replacement and Care of Filters (continued) —

3. a. Remove the two filters and dispose of properly.
 - b. Clean internal parts of the humidifier per the "Cleaning Your Humidifier" section of your owner's manual.
 - c. Install new filters inside the cabinet with the glue beads on the filter facing the center of the cabinet. Make sure the filters are resting on the floor of the cabinet.
 - d. Return the filter housing to the cabinet. Position the filter housing onto the filters. Align the back of the filter housing over the filters and between the rear ribs of the cabinet. Place the filter housing down onto the filters. Make sure the filters are captured inside the side flanges of the filter housing.
 - e. Position fan assembly onto the cabinet. Make sure the fan venturi (lowest cylinder section below the fan) is placed inside the filter housing. The left edge of the fan assembly housing should rest in the groove of the cabinet.
 - f. Replace water bottle and the water bottle cover. The right edge of the water bottle cover should rest in the groove of the cabinet.
4. The unit is ready for use or to be stored away for the next season.

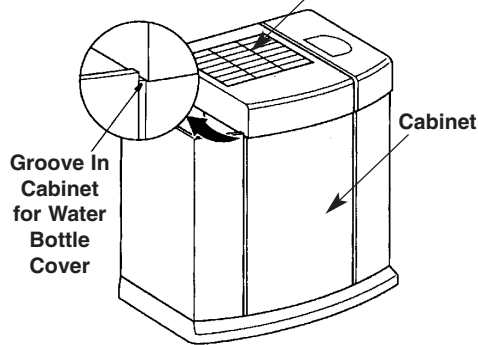
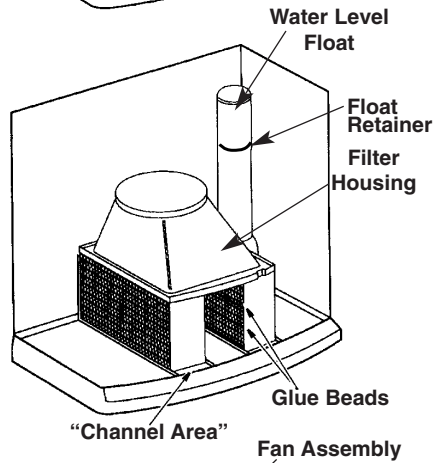
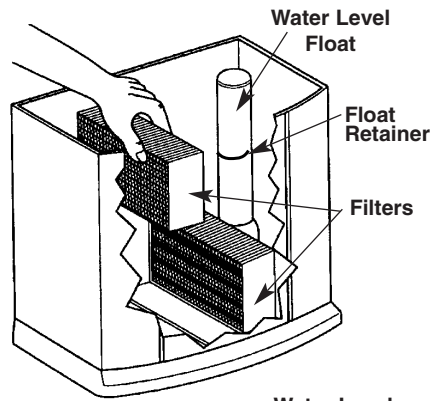

Cleaning Your Humidifier

WARNING: To reduce the risk of injury, fire or damage to humidifier, use only cleaners specifically recommended for humidifiers. Never use flammable, combustible or poisonous materials to clean your humidifier. To reduce the risk of scalds and damage to humidifier, never put hot water in humidifier.

CAUTION: Local water purity varies from area to area and under certain conditions water impurities and airborne bacteria may promote the growth of micro-organisms in the reservoir of the humidifier.

To retard bacteria growth that may cause odors and be harmful to your health, use only Emerson HDC-2R or HDC411 replacement filters. We also recommend using liquid EPA-approved bacteriostat, available at your local retail store.

NOTE: If it is necessary to use approved bacteriostat, follow directions correctly.

1. To make cleaning easier, the cabinet should be emptied. To accomplish this, allow the humidifier to run until the automatic shutoff turns the humidifier "OFF". Unplug the humidifier.

WARNING: If humidifier is not unplugged, fan could start after housing is removed.

Refer to pages 9 and 10 to remove parts if necessary.

NOTE: Before removing the internal parts of the humidifier cabinet, we recommend moving the humidifier to an area where floor coverings are not susceptible to water damage, i.e., kitchen or bath area.

2. Remove the bottle cover and water bottle. Grasp the fan assembly at the front center and rear center, and lift it off the cabinet. Set aside on a clean flat surface.
3. Lift the filter housing assembly out of the cabinet and set to the side.
4. Remove the filters and water level float from the humidifier cabinet. To remove the water level float simply pinch the float retainer to disengage it from the rear of the cabinet.
5. Empty any remaining water in the bottom of cabinet.
6. Proceed to "Bi-Weekly Maintenance" or "End-of-Season Maintenance".
7. Continue as described below.
8. Install new filters in the humidifier. Reinstall the float and float retainer into the cabinet and install the filter housing on top of the new filters. Position the fan assembly on top of the cabinet and return the humidifier to the desired location for use.
9. Refill water bottle with fresh cool water and replace bottle cover.
10. Plug the unit into a 120V A.C. power outlet and set the controls per the "Operating Humidifier Controls" section of this manual.

Cleaning Your Humidifier (continued)—————

Bi-Weekly Maintenance

Removing Scale

1. Pour one 8 ounce cup of undiluted white vinegar into the cabinet. Let solution stay in for 20 minutes.
2. Clean all interior surfaces with a soft brush. Dampen a soft cloth with undiluted white vinegar and wipe out the cabinet to remove scale.
3. Rinse thoroughly with clean warm water to remove scale and cleaning solution before disinfecting cabinet.
4. Dust the fan assembly and outside surfaces with a soft cloth only.

Disinfecting Water Bottle and Cabinet

1. Pour 1 gallon of water and 1 teaspoon chlorine bleach into the cabinet. Let solution stay for 20 minutes, swishing every few minutes. Wet all surfaces normally exposed to water.
2. Empty cabinet after 20 minutes. Rinse with water until bleach smell is gone. Allow unit to dry out completely.
3. Water bottle should be cleaned in the same manner.

End of Season Maintenance

1. Follow “Bi-Weekly Maintenance” instructions at end of humidification season.
2. Remove and throw away filters.
3. Let humidifier dry completely before storing. Do not store with water inside cabinet or water bottle.
4. Store in cool, dry location.
5. Install new filters in clean humidifier before next season begins.
6. “Bi-Weekly Maintenance” is also recommended if you do not plan to run the humidifier for one week or more.

CAUTION: Use liquid EPA-approved bacteriostat available from your local retail store.

Use of other water treatment products may damage the filter elements. Under no circumstances should you use water treatment products designed for Roto belt or Ultrasonic humidifiers.

Troubleshooting

| TROUBLE | PROBABLE CAUSE | REMEDY |
|--|---|--|
| Unit will not run and Fill Light is not on. | <ul style="list-style-type: none"> • Speed control in off position. • Selected humidity level is obtained. • No power. | <ul style="list-style-type: none"> • Turn speed control clockwise. • Raise humidistat setting if desired. • Check 120 volt source for power. |
| Unit will not shut off. | <ul style="list-style-type: none"> • Float is not free. | <ul style="list-style-type: none"> • Free float from obstruction. |
| Unit will not dry out completely. | <ul style="list-style-type: none"> • This is normal. | <ul style="list-style-type: none"> • A small amount of water remains in the cabinet after fill light comes on. |
| Bottle continues to empty. | <ul style="list-style-type: none"> • Air is entering water bottle. | <ul style="list-style-type: none"> • Check "E-Z-Fill Side-Cap" and valve assembly cap to ensure tightness. • Check for leak in water bottle. • Ensure gaskets for "E-Z-Fill Side Cap" are in place (see repair parts list). |
| Unit is not emptying during operation. | <ul style="list-style-type: none"> • Dirty filters. • Bottle cap plunger missing post in bottom of cabinet. | <ul style="list-style-type: none"> • Change to fresh new filters. • Check orientation of bottle. Reposition so that bottle cap plunger is depressed by post in bottom of cabinet. |
| Bottle not emptying and/or fill indicator turns on before bottle is empty. | <ul style="list-style-type: none"> • Unit is not set up on a level surface. (Float will not sense water at the rear of the cabinet.) | <ul style="list-style-type: none"> • Position unit level. (Some carpet padding may allow unit to set lower on the left side than the right side due to the weight of the water bottle on the left side. Install coasters under left casters to level. |
| Water smells. | <ul style="list-style-type: none"> • Poor water conditions. | <ul style="list-style-type: none"> • Clean humidifier as instructed in your Owner's Manual • Replace filters and use an EPA Approved Bacteriostat. |
| No mist appears. | <ul style="list-style-type: none"> • This is an evaporative humidifier. | <ul style="list-style-type: none"> • No mist will appear. |

FOR TECHNICAL HELP

If in the USA call 1-800-654-3545

If in Canada call 1-888-744-4687

Repair Parts

PARTS LIST FOR EMERSON HUMIDIFIER MODEL NO. HD7002 1 & HD7005 0

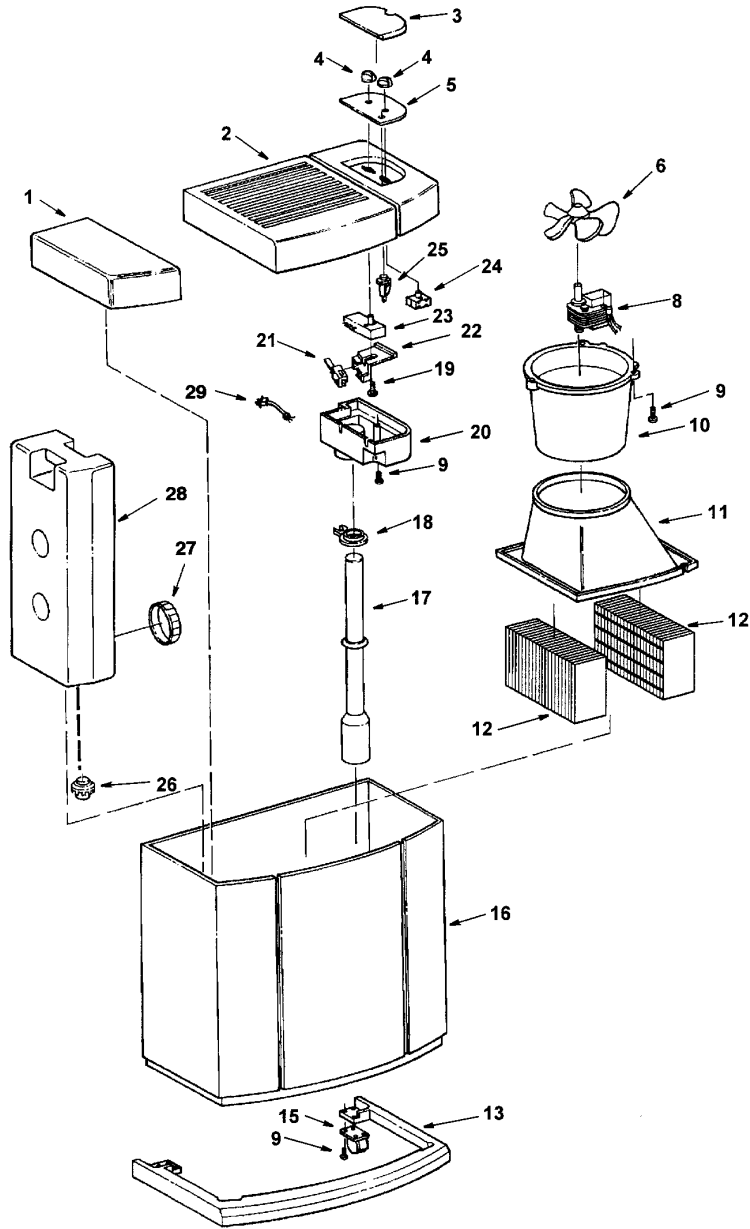

Repair Parts

| Key No. | Description | Model HD7002 1 | Model HD7005 0 |
|---------|------------------------------------|---------------------|---------------------|
| 1 | Cover, Bottle | 825807-1 | 825807 |
| 2 | Lid, Stationary | 825837-1 | 825837 |
| 3 | Cover, Dust | 825809 | 825809 |
| 4 | Knob | 826544-1 | 826544-1 |
| 5 | Label, Control | 826206 | 826206 |
| 6 | Fan | 822406-1 | 822406-1 |
| 8 | Motor | 828115 | 828115 |
| 9 | Screw, Pan Head Type "AB" 10 x 3/4 | 806742-5 | 806742-5 |
| 10 | Support, Motor | 828534 | 828534 |
| 11 | Housing, Filter | 825848 | 825848 |
| 12 | Filter, Evaporative | HDC-2R or HDC411 | HDC-2R or HDC411 |
| 13 | Rail, Kick | 825847-1 | 825847 |
| 15 | Caster, Twin Wheel | 828515 | 828515 |
| 16 | Cabinet | 825867-1 | 825867-3 |
| 17 | Float, Water Level | 823712-2 | 823712-2 |
| 18 | Retainer, Float | 824101-1 | 824101-1 |
| 19 | Screw, Pan Head Ty "AB" 8 x 3/8 | 808872-3 | 808872-3 |
| 20 | Cover, Electronics | 825806 | 825806 |
| 21 | Switch, Micro | 823728 | 823728 |
| 22 | Retainer, Micro Switch | 825855 | 825855 |
| 23 | Humidistat | 13805-02 | 13805-02 |
| 24 | Switch, Three Speed | 818983 | 818983 |
| 25 | Light, Pilot | 825858 | 825858 |
| 26 | Cap, Valve Assembly | 509229-1 | 509229-1 |
| 27 | "E-Z-Fill Side-Cap" | 824690 | 824690 |
| 28 | Bottle (includes Key No's 26 & 27) | 825849 | 825849 |
| 29 | Cord w/Plug | 821904 | 821904 |
| - | Owners Manual (Not Illustrated) | SP6470 | SP6470 |

FOR PARTS:

If in the USA call 1-800-654-3545

If in Canada call 1-866-258-7847

For more information about Emerson *MoistAIR*™ humidifiers
visit our website at www.moistair.com

FOR TECHNICAL HELP, CALL
(800) 654-3545 FROM USA OR (888) 744-4687 FROM CANADA
(Please have complete model number)

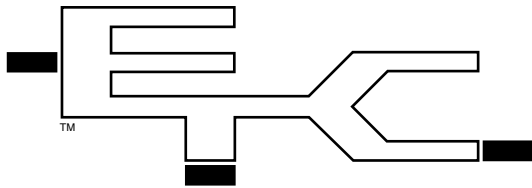

EMERSON TOOL COMPANY
9999 Highway 48
Markham, Ontario Canada L3P 3J3

© 2002 Emerson Electric Co.

Part. No. SP6470

Form. No. SP6470

Printed in Canada 06/02