



# GoldStar

website <http://biz.LGservice.com>

e-mail <http://www.LGservice.com/techsup.html>

## Room Air Conditioner

# SERVICE MANUAL

### CAUTION

- BEFORE SERVICING THE UNIT, READ THE SAFETY PRECAUTIONS IN THIS MANUAL.
- ONLY FOR AUTHORIZED SERVICE PERSONNEL.

**MODEL: WG8000R, KG8000R, WG1000R,  
KG1000R, WG1200R, KG1200R,  
Y5USC10-2R, Y5USC12-2R, Y5USC12-6R,  
LWC1232PAS**

# CONTENTS

## 1. PREFACE

1.1 SAFETY PRECAUTIONS.....	2
1.2 INSULATION RESISTANCE TEST.....	2
1.3 SPECIFICATIONS.....	3
1.4 FEATURES.....	4
1.5 CONTROL LOCATIONS.....	4

## 2. DISASSEMBLY INSTRUCTIONS

2.1 MECHANICAL PARTS.....	6
2.1.1 FRONT GRILLE.....	6
2.1.2 CABINET.....	6
2.1.3 CONTROL BOX.....	6
2.2 AIR HANDLING PARTS.....	7
2.2.1 AIR GUIDE AND BLOWER.....	7
2.2.2 FAN AND SHROUD.....	7
2.3 ELECTRICAL PARTS.....	8
2.3.1 OVERLOAD PROTECTOR.....	8
2.3.2 COMPRESSOR.....	8
2.3.3 CAPACITOR.....	8
2.3.4 POWER CORD.....	9
2.3.5 ROTARY SWITCH.....	9
2.3.6 MOTOR.....	9
2.4 REFRIGERATION CYCLE.....	10
2.4.1 CONDENSER.....	10
2.4.2 EVAPORATOR.....	10
2.4.3 CAPILLARY TUBE.....	10

## 3. INSTALLATION

3.1 SELECT THE BEST LOCATION.....	13
3.2 CHECK OF INSTALLATION.....	13
3.3 HOW TO DRAIN.....	13
3.4 HOW TO INSTALL.....	14
3.5 HOW TO USE THE REVERSIBLE INLET GRILLE...	18

## 4. TROUBLESHOOTING GUIDE

4.1 OUTSIDE DIMENSIONS.....	19
4.2 PIPING SYSTEM.....	19
4.3 TROUBLESHOOTING GUIDE.....	20

## 5. SCHEMATIC DIAGRAM

5.1 CIRCUIT DIAGRAM.....	29
5.2 ELECTRONIC CONTROL DEVICE.....	30
5.3 COMPONENTS LOCATION (OFF MAIN P.C.B ASSEMBLY).....	31
5.4 COMPONENTS LOCATION (OFF DISPLAY P.C.B ASSEMBLY).....	31

## 6. EXPLODED VIEW.....32

## 7. REPLACEMENT PARTS LIST.....33

## 1. PREFACE

This SERVICE MANUAL provides various service information, including the mechanical and electrical parts etc. This room air conditioner was manufactured and assembled under a strict quality control system. The refrigerant is charged at the factory. Be sure to read the safety precautions prior to servicing the unit.

### 1.1 SAFETY PRECAUTIONS

1. When servicing the unit, set the ROTARY SWITCH or POWER SWITCH to OFF and unplug the power cord.
2. Observe the original lead dress.  
If a short circuit is found, replace all parts which have been overheated or damaged by the short circuit.
3. After servicing the unit, make an insulation resistance test to protect the customer from being exposed to shock hazards.

### 1.2 INSULATION RESISTANCE TEST

1. Unplug the power cord and connect a jumper between 2 pins (black and white).
2. The grounding conductor (green) is to be open.
3. Measure the resistance value with an ohm meter between the jumpered lead and each exposed metallic part on the equipment at all mode (except OFF).
4. The value should be over 1MΩ.

### 1.3 SPECIFICATIONS

ITEMS		MODELS			
		8000 Btu Series	10,000 Btu Series	12,000 Btu Series	
POWER SUPPLY		1ø, 115, 60Hz		1ø, 220, 60Hz	
COOLING CAPACITY (Btu/h)		8,000	10,000	12,000	
INPUT (W)		800	1,020	1,220	
RUNNING CURRENT (A)		7.3	9.2	11.0	5.5
E.E.R (BTU/W.h)		10.0	9.8		
OPERATING CONDITION	INDOOR (°C)	26.7(DB)*		19.4(WB)**	
	OUTDOOR (°C)	35(DB)*		23.9(WB)**	
REFRIGERANT (R-22) CHARGE		385g (13.6 oz)		530g (18.7 oz)	555g (19.5 oz)
FAN, INDOOR		BLOWER or TURBO FAN			
FAN, OUTDOOR		PROPELLER TYPE FAN WITH SLINGER-RING			
FAN SPEEDS, FAN/COOLING		3/3			
FAN MOTOR		6 POLES			
OPERATION CONTROL		TOUCH & REMOTE CONTROL			
ROOM TEMP. CONTROL		THERMISTOR			
AIR DIRECTION CONTROL		VERTICAL LOUVER (RIGHT & LEFT)			
		HORIZONTAL LOUVER (UP & DOWN)			
CONSTRUCTION		SLIDE IN-OUT CHASSIS			
PROTECTOR	COMPRESSOR	OVERLOAD PROTECTOR			
	FAN MOTOR	INTERNAL THERMAL PROTECTOR			
OUTSIDE DIMENSION (W x H x D)	(inch)	18 <sup>1</sup> / <sub>2</sub> x 13 <sup>7</sup> / <sub>8</sub> x 20 <sup>11</sup> / <sub>16</sub>		23 <sup>5</sup> / <sub>8</sub> x 14 <sup>31</sup> / <sub>32</sub> x 22 <sup>5</sup> / <sub>16</sub>	
	(mm)	470 x 353 x 525		600 x 380 x 567	

\* DB: Dry Bulb

\*\* WB: Wet Bulb

NOTE : Specifications are subject to minor change without notice for further improvement.

## 1.4 FEATURES

- Designed for COOLING ONLY.
- Powerful and whispering cooling.
- Slide-in and slide-out chassis for the simple installation and service.
- Side air-intake, side cooled-air discharge.
- Washable one-touch filter
- Compact size
- Reliable and efficient rotary compressor is equipped.

## 1.5 CONTROL LOCATIONS

### 1.5.1 COOLING ONLY MODEL

#### • VENTILATION

The ventilation lever must be in the CLOSE position in order to maintain the best cooling conditions.

When a fresh air is necessary in the room, set the ventilation lever OPEN position.

The damper is opened and room air is exhausted.

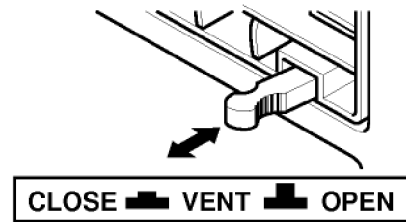

### 1.5.2 COOLING ONLY MODEL WITH REMOTE CONTROL AND TOUCH TYPE

#### • DISPLAY

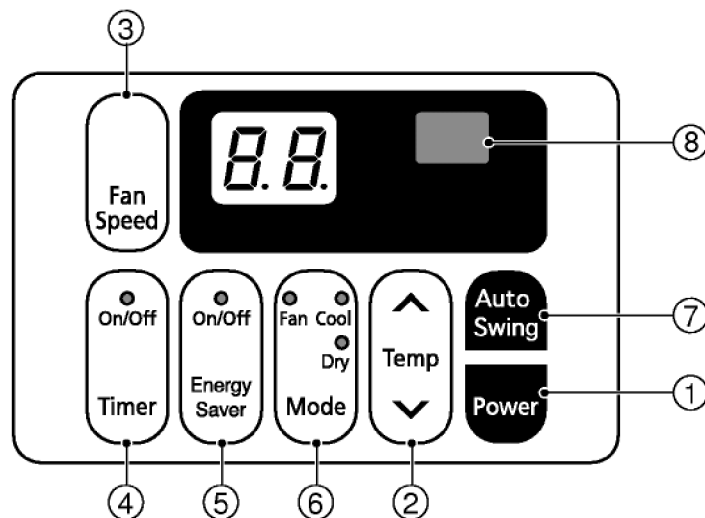
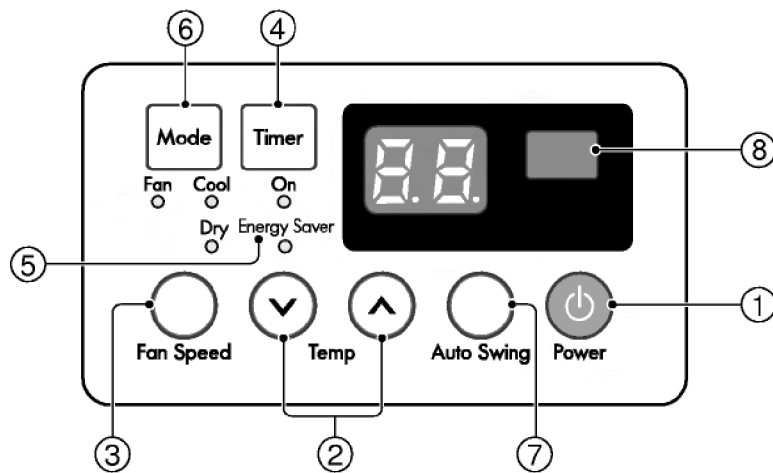

## • REMOTE CONTROLLER

**Precaution:** The Remote Controller will not function properly if strong light strikes the sensor window of the air conditioner or if there are obstacles between the Remote Controller and the air conditioner.

### 1 POWER

- To turn the air conditioner ON, push the button. To turn the air conditioner OFF, push the button again.
- This button takes priority over any other buttons.
- When you first turn it on, the air conditioner is on the High cool mode and the temp. at 72°F(22°C).

### 2 TEMPERATURE SETTING

- This button can automatically control the temperature of the room. The temperature can be set within a range of 60°F to 86°F by 1°F. (16°C to 30°C by 1°C)  
Select the lower number for lower temperature of the room.

### 3 FAN SPEED

- Everytime you push this button it is set as follows. {High(F3) → Low(F1) → Med(F2) → High(F3)...}.

### 4 ON/OFF TIMER

- STOPPING OPERATION

- Everytime you push this button, when the air conditioner is operating, timer is set as follows. (1Hour → 2Hours → 3Hours → 4Hours → 5Hours → 6Hours → 7Hours → 8Hours → 9Hours → 10Hours → 11Hours → 12Hours → Cancel)
- The Setting Temperature will be raised by 2°F (1°C) 30min. later and by 2°F (1°C) after another 30 min.

- STARTING OPERATION

- Everytime you push this button, when the air conditioner is not operating, timer is set as follow. (1Hour → 2Hours → 3Hours → 4Hours → 5Hours → 6Hours → 7Hours → 8Hours → 9Hours → 10Hours → 11Hours → 12Hours → Cancel)

### 5 ENERGY SAVER (AVAILABLE IN SOME MODELS)

- If the switch is set to "On", the fan stops when the compressor stops cooling. Approximately every 3 minutes the fan will turn on and check the room air to determine if cooling is needed.

### 6 MODE

- Everytime you push this button, it will toggle between COOL, FAN and DRY.

### 7 AUTO SWING

- This button can automatically control the air flow direction.

### 8 REMOCON SIGNAL RECEIVER

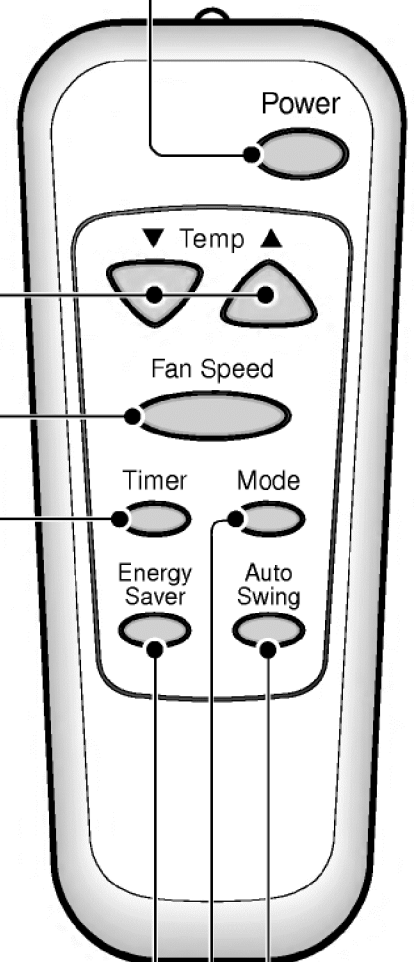

## AUTO RESTART

*In failure of electric power, the unit runs as previous setting operation. (Available in some models)*

## 2. DISASSEMBLY INSTRUCTIONS

— Before the following disassembly, POWER SWITCH set to OFF and disconnect the power cord.

### 2.1 MECHANICAL PARTS

#### 2.1.1 FRONT GRILLE

1. Open the Inlet grille upward or downward.
2. Remove the screw which fastens the front grille.
3. Pull the front grille from the right side.
4. Remove the front grille.
5. Re-install the component by referring to the removal procedure, above.(See Figure 1)

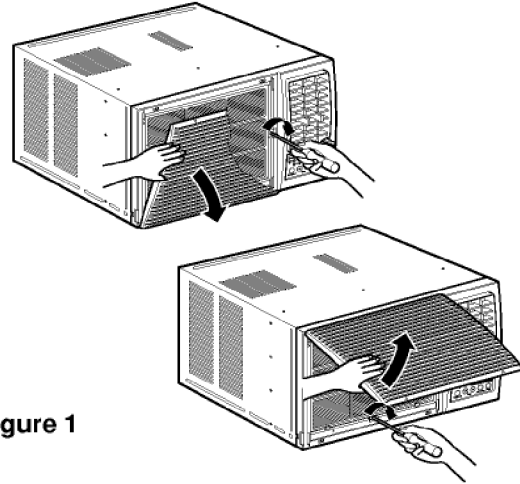

Figure 1

#### 2.1.2 CABINET

1. After disassembling the FRONT GRILLE, remove the 2 screws which fasten the cabinet at both sides.
2. Remove the 2 screws which fasten the cabinet at back.
3. Pull the base pan forward. (See Figure 2)
4. Remove the cabinet.
5. Re-install the component by referring to the removal procedure, above.

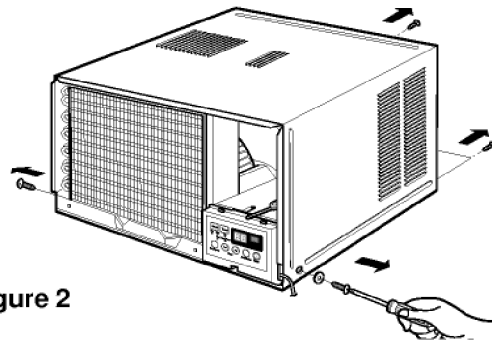

Figure 2

#### 2.1.3 CONTROL BOX

1. Disconnect the unit from the power source.
2. Remove the front grille. (Refer to section 2.1.1)
3. Remove the cabinet. (Refer to section 2.1.2)
4. Remove the screw which fastens the control box cover.
5. Remove the housing which connects motor wire in the control box.
6. Remove the 3 leads from the compressor. (Refer to section 2.3.1)
7. Discharge the capacitor by placing a 20,000 ohm resistor across the capacitor terminals.
8. Remove the 2 screws which fasten the control box. (See Figure 3)
9. Pull the control box forward completely.
10. Re-install the components by referring to the removal procedure, above. (See Figure 3) (Refer to the circuit diagram found on page 24 in this manual or on the control box.)

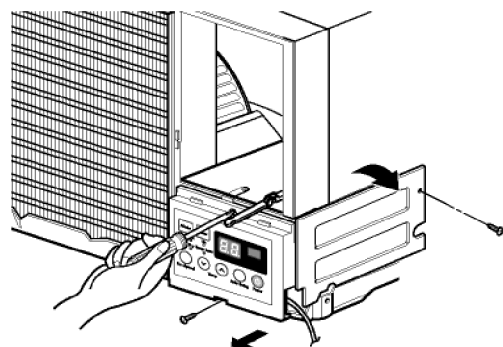

Figure 3

## 2.2 AIR HANDLING PARTS

### 2.2.1 AIR GUIDE AND BLOWER

1. Remove the front grille. (Refer to section 2.1.1)
2. Remove the cabinet. (Refer to section 2.1.2)
3. Remove the control box. (Refer to section 2.1.3)
4. Remove the 3 screws which fasten the brace.
5. Remove the brace.
6. Remove the 2 screws which fasten the evaporator.
7. Move the evaporator forward and pulling it upward slightly. (See Figure 4)
8. Move the evaporator to the left carefully.
9. Pull out the hook of orifice by pushing the tabs and remove it. (See Figure 5)
10. Remove the clamp with a hand plier which secures the blower.
11. Remove the blower.
12. Remove the 4 screws which fasten the air guide from the barrier.
13. Move the air guide backward, pulling out from the base pan.
14. Re-install the components by referring to the removal procedure, above.

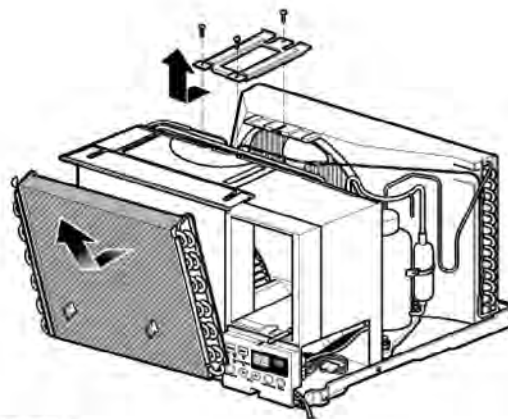

Figure 4

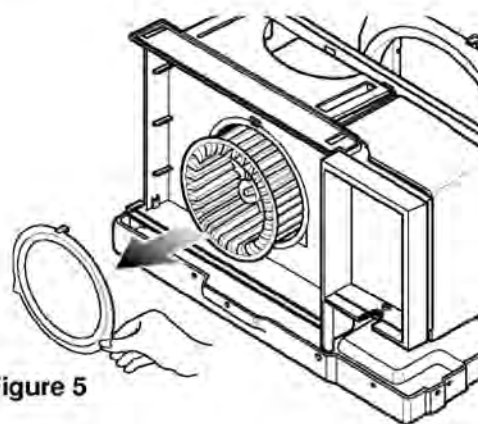

Figure 5

### 2.2.2 FAN AND SHROUD

1. Remove the cabinet. (Refer to section 2.1.2)
2. Remove the brace (Refer to section 2.2.1)
3. Remove the 3 screws which fasten the condenser.
4. Move the condenser to the left carefully.
5. Remove the clamp which secures the fan.
6. Remove the fan and then pull out the shroud. (See Figure 6)
7. Re-install by referring to the removal procedure.

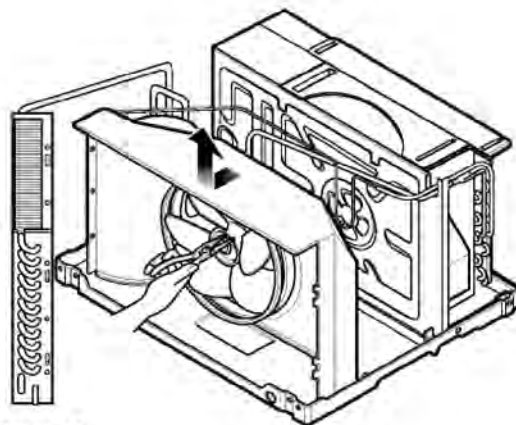

Figure 6

## 2.3 ELECTRICAL PARTS

### 2.3.1 OVERLOAD PROTECTOR

1. Remove the cabinet. (Refer to section 2.1.2)
2. Remove the nut which fastens the terminal cover.
3. Remove the terminal cover. (See Figure 7)
4. Remove all the leads from the overload protector.
5. Remove the overload protector.
6. Re-install the component by referring to the removal procedure, above.

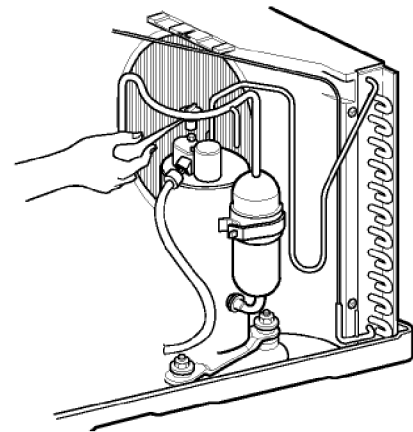

Figure 7

### 2.3.2 COMPRESSOR

1. Remove the cabinet. (Refer to section 2.1.2)
2. Discharge the refrigerant system using a Freon™ Recovery System.  
If there is no valve to attach the recovery system, install one (such as a WATCO A-1) before venting the Freon™. Leave the valve in place after servicing the system.
3. Remove the overload protector. (Refer to section 2.3.1)
4. After purging the unit completely, unbraid the suction and discharge tubes at the compressor connections.
5. Remove the 3 nuts and the 3 washers which fasten the compressor.
6. Remove the compressor. (See Figure 8)
7. Re-install the components by referring to the removal procedure, above.

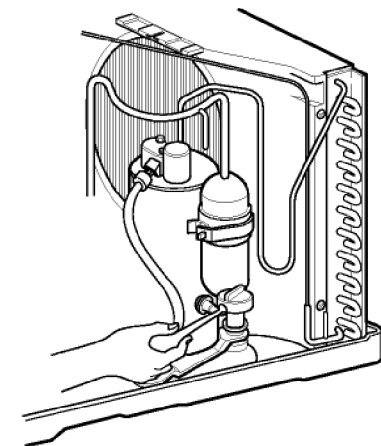

Figure 8

### 2.3.3 CAPACITOR

1. Remove the control box. (Refer to section 2.1.3)
2. Remove the screw which fasten control panel from control box.
3. Remove the screw which located in the front.
4. Open the bottom side of control box.
5. Remove the screw and the clamp which fastens the capacitor.
6. Disconnect all the leads of capacitor terminals.
7. Re-install the components by referring to the removal procedure, above. (See Figure 9)

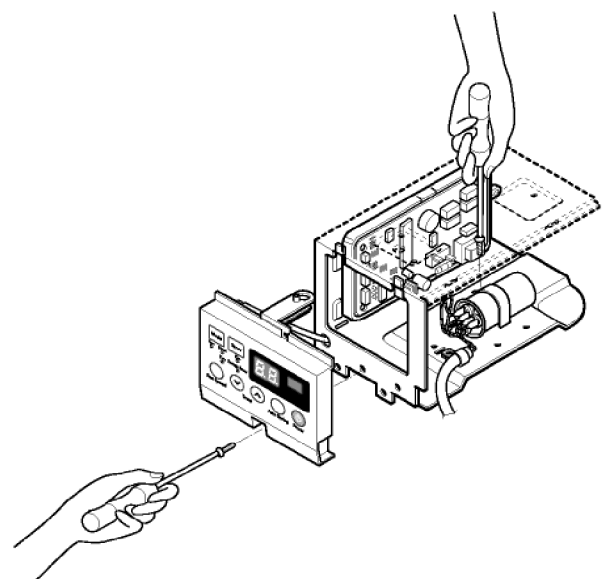

Figure 9

### 2.3.4 POWER CORD

1. Remove the control box. (Refer to section 2.1.3)
2. Open the control box. (Refer to section 2.3.3)
3. Disconnect the grounding screw from the control box.
4. Disconnect the 2 receptacles.
5. Remove a screw which fastens the clip cord. (See Figure 10)
6. Remove the power cord.
7. Re-install the component by referring to the above removal procedure, above. (Use only one ground-marked hole  $\ominus$  for ground connection.)
8. If the supply cord of this appliance is damaged, it must be replaced by the special cord. (The special cord means the cord which has the same specification marked on the supply cord attached at the unit.)

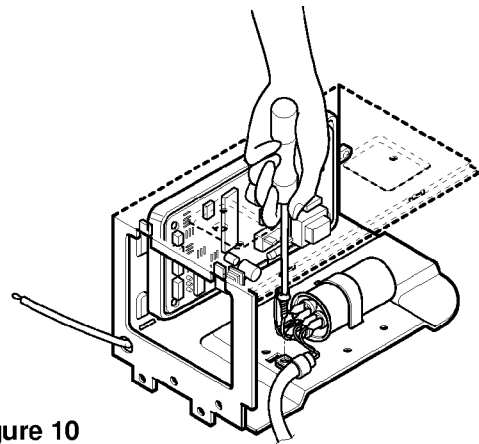

Figure 10

### 2.3.5 MOTOR

1. Remove the cabinet. (Refer to section 2.1.2)
2. Remove the evaporator. (Refer to section 2.2.1)
3. Remove the orifice. (Refer to section 2.2.1)
4. Remove the blower. (Refer to section 2.2.1)
5. Remove the fan. (Refer to section 2.2.2)
6. Remove the control box cover and housing of the motor in the control box. (Refer to section 2.1.3)
7. Remove the 2 screws which fasten the motor from the mount motor. (See Figure 11)
8. Remove the motor.
9. Re-install the components by referring to the removal procedure, above. (See Figure 11)

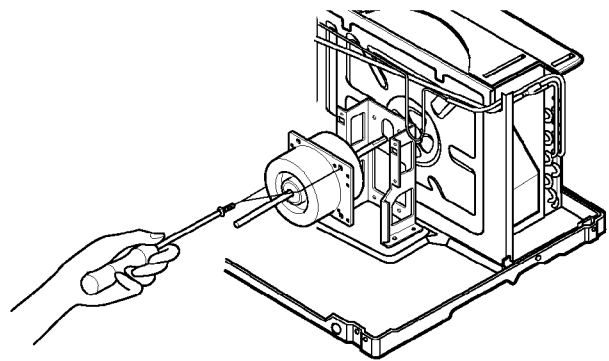

Figure 11

## 2.4 REFRIGERATING CYCLE

### **CAUTION**

Discharge the refrigerant system using a Freon™ Recovery System.  
If there is no valve to attach the recovery system, install one (such as a WATCO A-1) before venting the Freon™. Leave the valve in place after servicing the system.

### 2.4.1 CONDENSER

1. Remove the cabinet. (Refer to section 2.1.2)
2. Remove the 3 screws which fasten the brace.(Refer to section 2.2.1)
3. Remove the 3 screws which fasten the condenser and shroud.
4. After discharging the refrigerant completely, unbrazed the interconnecting tube at the condenser connections.
5. Remove the condenser carefully.
6. Re-install the component by referring to notes. (See Figure 12)

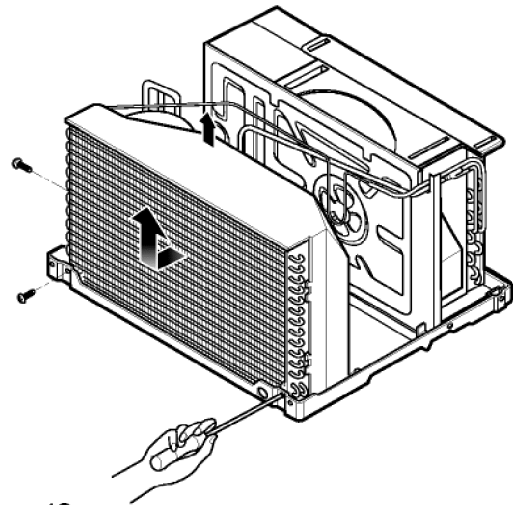

Figure 12

### 2.4.2 EVAPORATOR

1. Remove the cabinet. (Refer to section 2.1.2)
2. Remove the 2 screws which fasten the evaporator.
3. Move the evaporator sideways carefully. (Refer to section 2.2.1)
4. After discharging the refrigerant completely, unbrazed the interconnecting tube at the evaporator connections.
5. Remove the evaporator carefully.
6. Re-install the component by referring to notes. (See Figure 13)

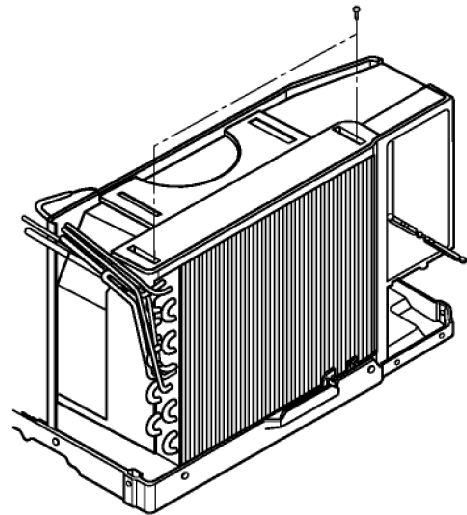

Figure 13

### 2.4.3 CAPILLARY TUBE

1. Remove the cabinet. (Refer to section 2.1.2)
2. After discharging the refrigerant completely, unbrazed the interconnecting tube at the capillary tube.(See caution above)
3. Remove the capillary tube.
4. Re-install the component by referring to notes.

## NOTES

— Replacement of the refrigeration cycle.

1. When replacing the refrigeration cycle, be sure to Discharge the refrigerant system using a Freon™ recovery System.  
If there is no valve to attach the recovery system, install one (such as a WATCO A-1) before venting the Freon™. Leave the valve in place after servicing the system.
2. After discharging the unit completely, remove the desired component, and unbrazed the pinch-off tubes.
3. Solder service valves into the pinch-off tube ports, leaving the valves open.
4. Solder the pinch-off tubes with Service valves.
5. Evacuate as follows.
  - 1) Connect the vacuum pump, as illustrated figure 14A.
  - 2) Start the vacuum pump, slowly open manifold valves A and B with two full turns counterclockwise and leave the valves open. The vacuum pump is now pulling through valves A and B up to valve C by means of the manifold and entire system.

### CAUTION

If high vacuum equipment is used, just crack valves A and B for a few minutes, then open slowly with the two full turns counterclockwise. This will keep oil from foaming and being drawn into the vacuum pump.

- 3) Operate the vacuum pump for 20 to 30 minutes, until 600 microns of vacuum is obtained. Close valves A and B, and observe vacuum gauge for a few minutes. A rise in pressure would indicate a possible leak or moisture remaining in the system. With valves A and B closed, stop the vacuum pump.
- 4) Remove the hose from the vacuum pump and place it on the charging cylinder. See figure 14B.  
Open valve C.  
Discharge the line at the manifold connection.
- 5) The system is now ready for final charging.

6. Recharge as follows :

- 1) Refrigeration cycle systems are charged from the High-side. If the total charge cannot be put in the High-side, the balance will be put in the suction line through the access valve which you installed as the system was opened.
- 2) Connect the charging cylinder as shown in figure 14B.  
With valve C open, discharge the hose at the manifold connection.
- 3) Open valve A and allow the proper charge to enter the system. Valve B is still closed.
- 4) If more charge is required, the high-side will not take it. Close valve A.
- 5) With the unit running, open valve B and add the balance of the charge.
  - a. Do not add the liquid refrigerant to the Low-side.
  - b. Watch the Low-side gauge; allow pressure to rise to 30 lbs.
  - c. Turn off valve B and allow pressure to drop.
  - d. Repeat steps b. and c. until the balance of the charge is in the system.
- 6) When satisfied the unit is operating correctly, use the pinch-off tool with the unit still running and clamp on to the pinch-off tube. Using a tube cutter, cut the pinch-off tube about 2 inches from the pinch-off tool. Use sil-fos solder and solder pinch-off tube closed. Turn off the unit, allow it to set for a while, and then test the leakage of the pinch-off connection.

**Equipment needed:** Vacuum pump, Charging cylinder, Manifold gauge, Brazing equipment. Pin-off tool capable of making a vapor-proof seal, Leak detector, Tubing cutter, Hand Tools to remove components, Service valve.

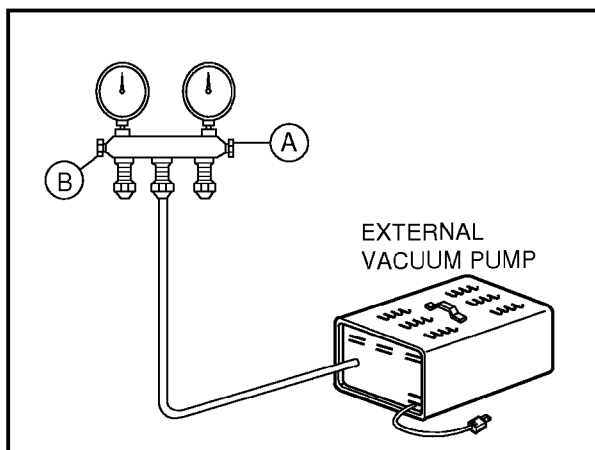
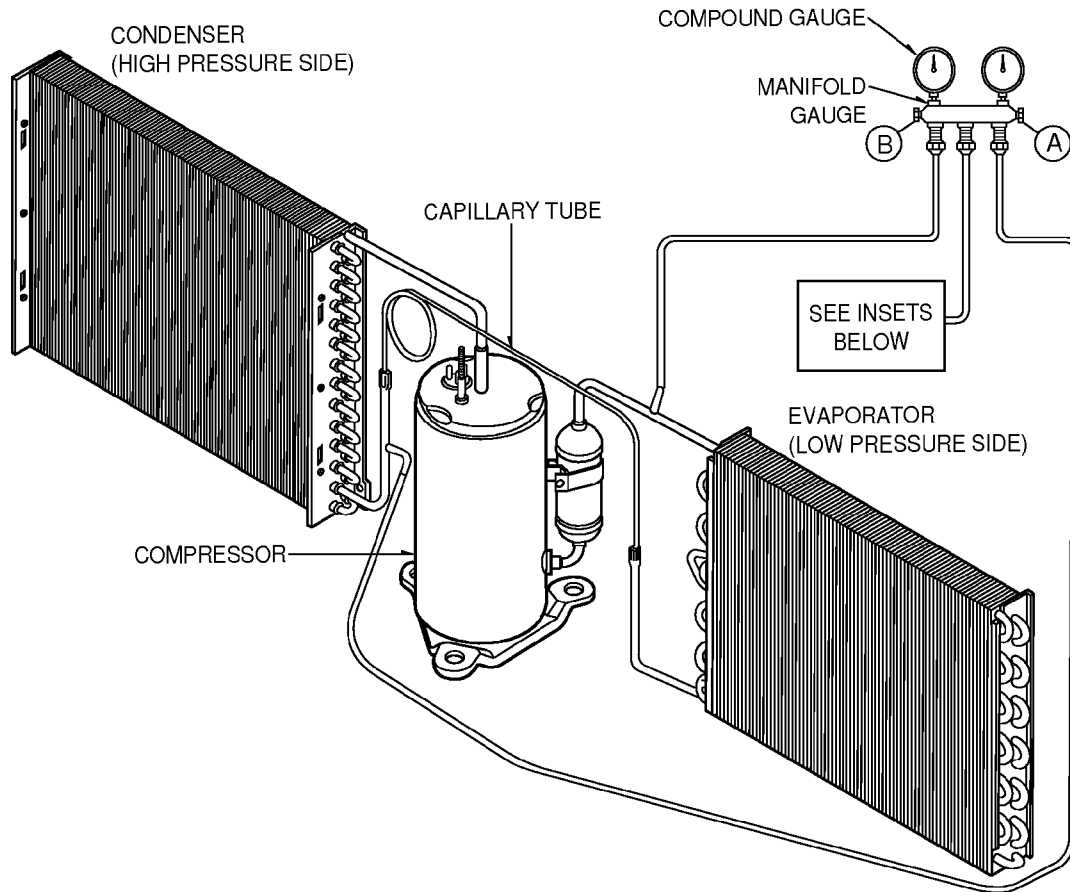

**Figure 14A-Pulling Vacuum**

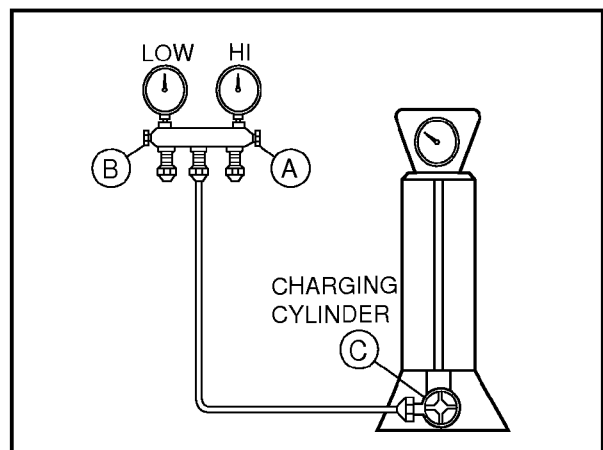

**Figure 14B-Charging**

## 3. INSTALLATION

### 3.1 SELECT THE BEST LOCATION

1. To prevent vibration and noise, make sure the unit is installed securely and firmly.
2. Install the unit where the sunlight does not shine directly on the unit.
3. The outside of the cabinet must extend outward for at least 11" and there should be no obstacles, such as a fence or wall, within 20" from the back of the cabinet because it will prevent heat radiation of the condenser.  
Restriction of outside air will greatly reduce the cooling efficiency of the air conditioner.

#### ⚠ CAUTION

All side louvers of the cabinet must remain exposed to the outside of the structure.

4. Install the unit a little slanted so the back is slightly lower than the front (about  $\frac{1}{2}$ "). This will help force condensed water to the outside.
5. Install the unit from the bottom about 30"~60" above the floor level.

### 3.2 CHECK OF INSTALLATION

The setting conditions must be checked prior to initial starting.

The undermentioned items are especially important checking points when the installation is finished.

1. Grounding wire (Green or Green and Yellow) is provided in the power cord. The green wire must be grounded.
2. Connect to a single-outlet 15A circuit.
3. To avoid vibration or noise, make sure the air conditioner is installed securely.
4. Avoid placing furniture or draperies in front of the air inlet and outlet.

### 3.3. HOW TO DRAIN (When using drain pipe)

The air conditioner must be installed horizontally or tilted slightly to the outside for proper water drainage.

On exceptionally hot and humid days the air conditioner may overflow condensed water.

If the air conditioner is used in a hot and high humidity zone, exchange the ① HOLE RUBBER for the ② DRAIN PIPE. (See figure 16, figure 17.)

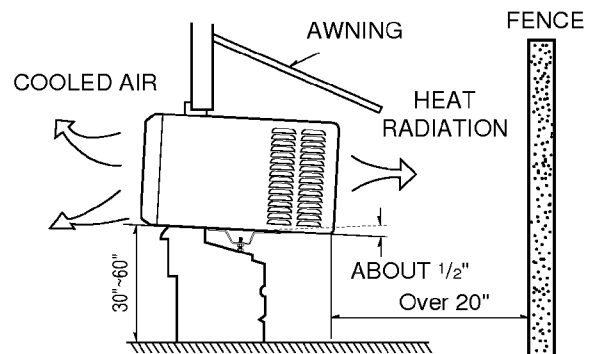

Figure 15

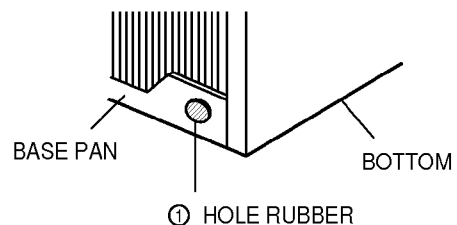

Figure 16

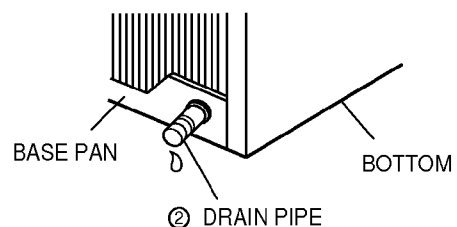
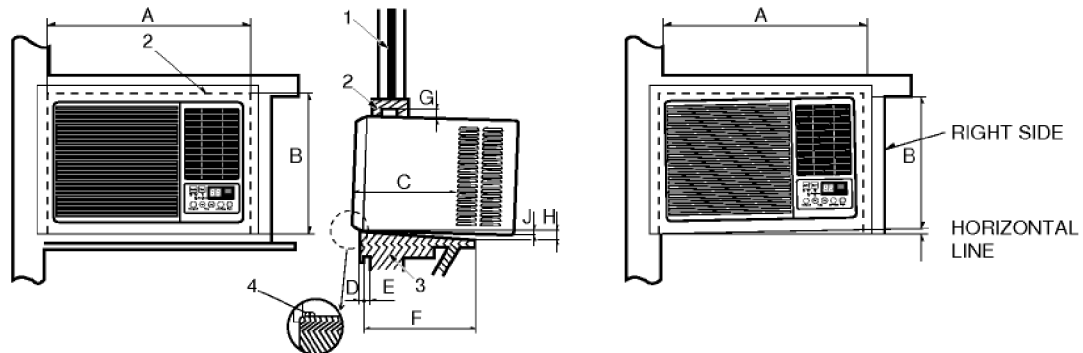

Figure 17

### 3.4 HOW TO INSTALL

#### 3.4.1 WHEN USING GASKET



- 1. WINDOW (WIDTH-A, HEIGHT-B)
- 2. GASKET
- 3. WALL

- 4. DETAILS 5.1 x 30 ROUND HEAD WOOD SCREWS

A	B	C	D	E	F	G	H	J	K
495mm (19 1/2")	366mm (14 7/16")	250mm (10")	30mm (1 1/16")	0~25mm (0~1")	OVER 420mm (OVER 16 17/32")	12mm (1/2")	32mm (1 1/4")	5~10mm (3/16"~3/8")	0~5mm (0~3/16")

#### 3.4.2 WHEN USING INSTALLATION KITS

##### A. WINDOW REQUIREMENTS

This unit is designed for installation in standard double hung windows with actual opening widths from 22" to 36".

The top and bottom window sash must open sufficiently to allow a clear vertical opening of 15" from the bottom of the upper sash to the window stool.

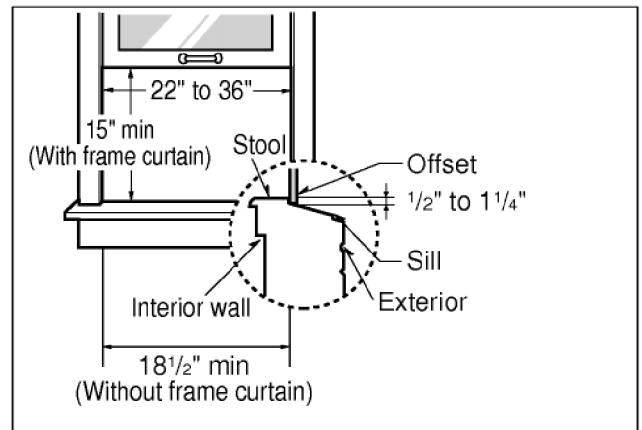

##### B. INSTALLATION KITS CONTENTS

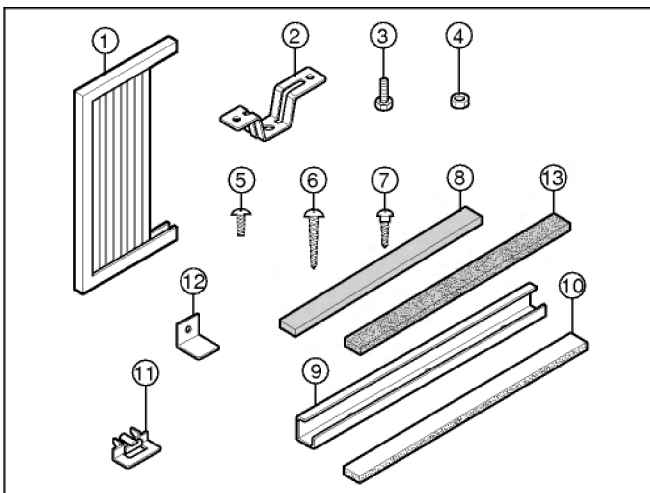

NO.	NAME OF PARTS	Q'TY
1	FRAME CURTAIN	2
2	SILL SUPPORT	2
3	BOLT	2
4	NUT	2
5	SCREW(TYPE A)	16
6	SCREW(TYPE B)	3
7	SCREW(TYPE C)	5
8	FOAM-STRIP	1
9	UPPER GUIDE	1
10	FOAM-PE	1
11	FRAME GUIDE	2
12	WINDOW LOCKING BRACKET	1
13	FOAM-PE	1

## SUGGESTED TOOL REQUIREMENTS

**SCREWDRIVER(+, -), RULER, KNIFE, HAMMER, PENCIL, LEVEL**

### PREPARATION OF CHASSIS

1. Remove the screws which fasten the cabinet at both sides and at the back.
2. Slide the unit from the cabinet by gripping the base pan handle and pulling forward while bracing the cabinet.
3. Cut the window sash seal to the proper length. Peel off the backing and attach the foam-pe ⑬ to the underside of the window sash.
4. Remove the backing from the top upper guide Foam PE ⑩ and attach it to the bottom of the upper guide ⑨.
5. Attach the upper guide onto the top of the cabinet with 3 type A screws.
6. Insert the frame guides ⑪ into the bottom of the cabinet.
7. Insert the Frame Curtain ① into the upper guide ⑨ and frame guides ⑪.
8. Fasten the curtains to the unit with 4 Type A screws.

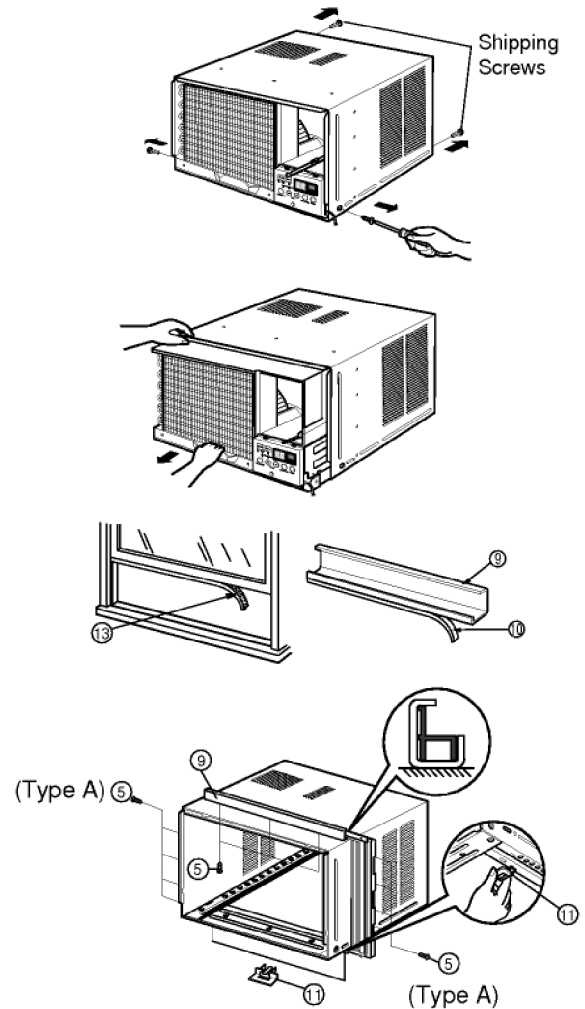

### CABINET INSTALLATION

1. Open the window. Mark a line on center of the window stool(or desired air conditioner location). Carefully place the cabinet on the window stool and align the center mark on the bottom front with the center line marked in the window stool.
2. Pull the bottom window sash down behind the upper guide until it meets.

#### NOTE:

- Do not pull the window sash down so tightly that the movement of Frame Curtain is restricted.

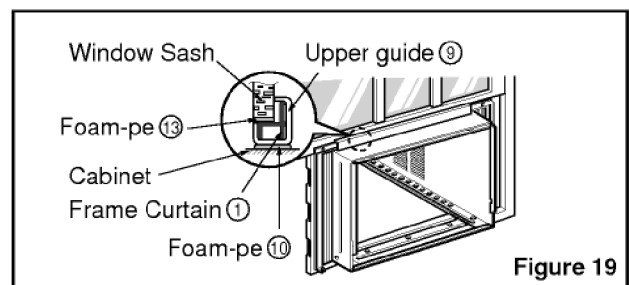
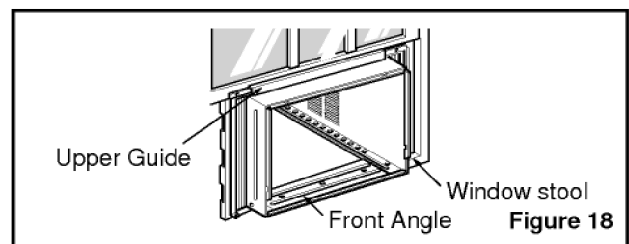

3. Loosely assemble the sill support using the parts in Figure 20.

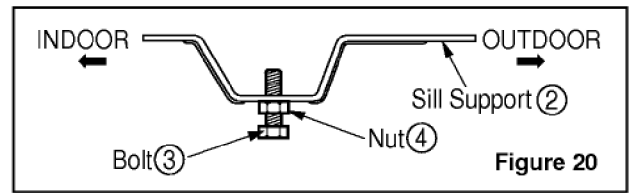

4. Select the position that will place the sill support near the outer most point on sill (See Figure 21)

**NOTE:** Be careful when you install the cabinet (frame guides ① are broken so easily).

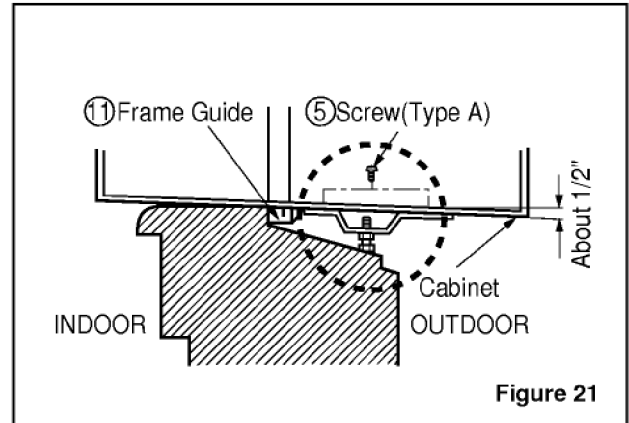

5. Attach the sill support to the cabinet track hole in relation to the selected position using 2 Type A screws in each support(See Figure 21).

6. The cabinet should be installed with a very **slight tilt (about 1/2") downward** toward the outside (See Figure 22).  
Adjust the bolt and the nut of sill support for balancing the cabinet.

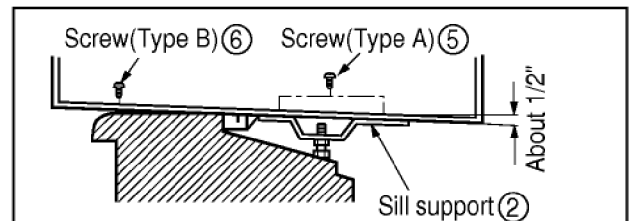

7. Attach the cabinet to the window stool by driving the screws ⑥(Type B: Length sixteen millimeters and below.) through the front angle into window stool.

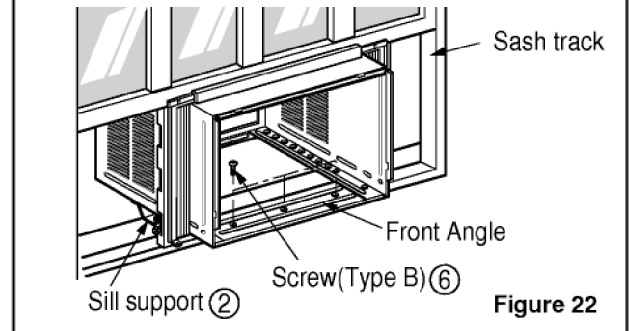

8. Pull each Frame curtain fully to each window sash track, and repeat step 2.

9. Attach each Frame curtain the window sash using screws ⑦(Type C).(See Figure 23)

**CAUTION: DO NOT DRILL A HOLE IN THE BOTTOM PAN.**

The unit is designed to operate with approximately 1/2" of water in bottom pan.

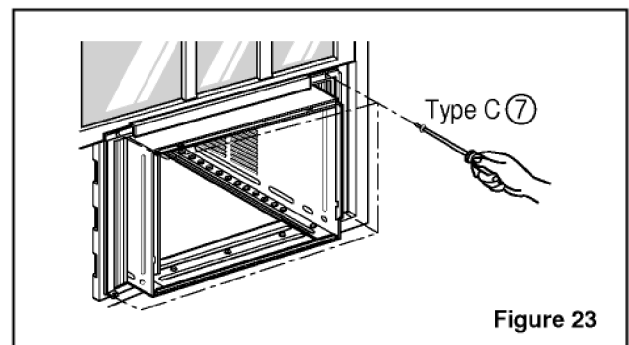

10. Slide the unit into the cabinet.(See Figure 24)

**CAUTION:** For security purpose, reinstall screws(Type A) at cabinet's sides.

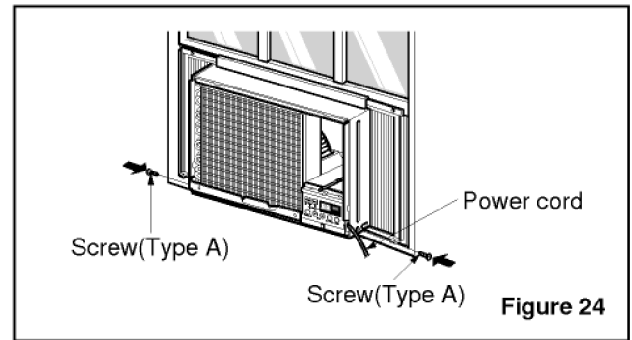

11. Cut the foam-strip ⑧ to the proper length and insert between the upper window sash and the lower window sash.  
(See Figure 25)

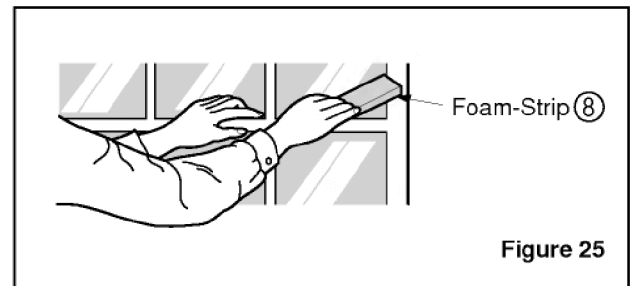

12. Attach the window locking bracket ⑫ with a type C screw. (See Figure 26)

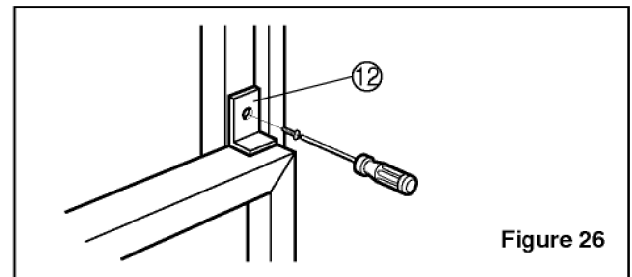

13. Attach the front grille to the cabinet by inserting the tabs on the grille into the tabs on the front of the cabinet. Push the grille in until it snaps into place.  
(See Figure 27)

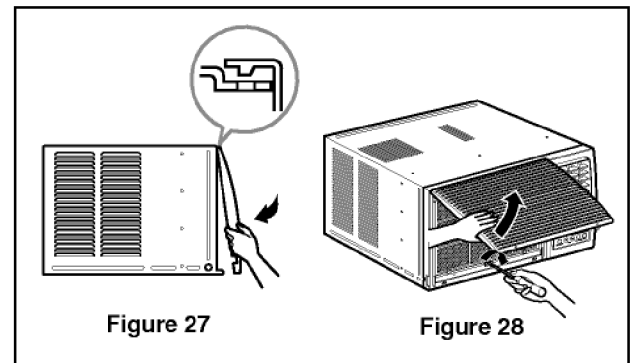

14. Lift the inlet grille and secure it with a type A screw through the front grille.  
(See Figure 28)

15. **Window installation of room air conditioner is now completed. See ELECTRICAL DATA for attaching power cord to electrical outlet.**

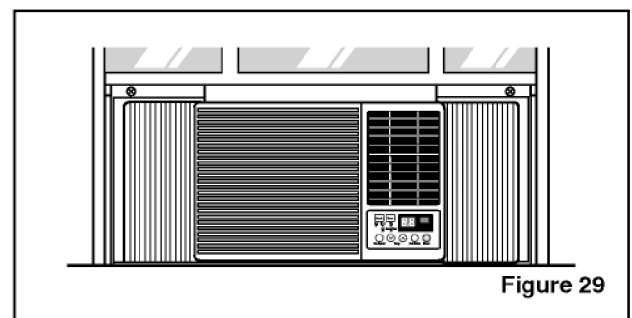

### 3.5 HOW TO USE THE REVERSIBLE INLET GRILLE

1. If you want to pull out the filter upward, open the inlet grille slightly. Turn inside out the front grille. Disassemble the inlet grille from the front grille with separating the hinged part by inserting a "—" type screw-driver tip. Rotate the inlet grille 180 degrees and insert the hooks into the lower holes of front grille. Then, insert the filter. (See Figure 30, 31)

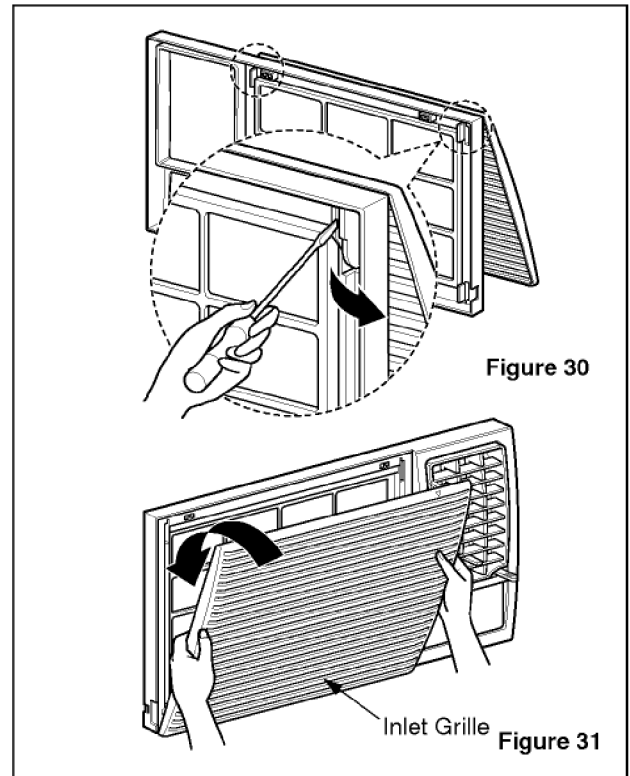

2. Attach the front grille to the cabinet by inserting the tabs on the grille into the tabs on the front of the cabinet. Push the grille in until it snaps into place. (See Figure 32)

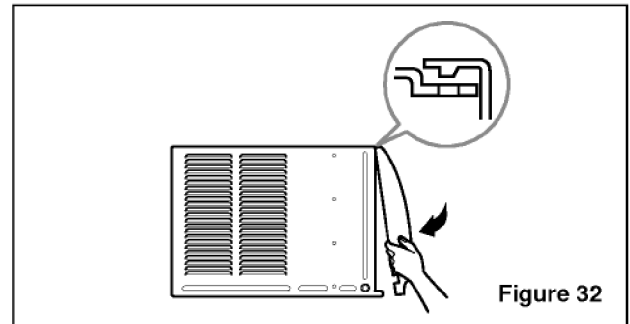

3. Lift the inlet grille and secure it with a type A screw through the front grille. (See Figure 33)

4. If you want to pull out the filter downward, use the reversible inlet grille without change. (The grille is already assembled for that way.)

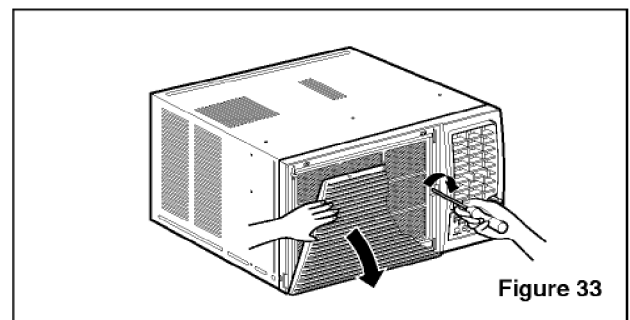

# 4. TROUBLESHOOTING GUIDE

## 4.1 OUTSIDE DIMENSIONS

unit: mm(inch)

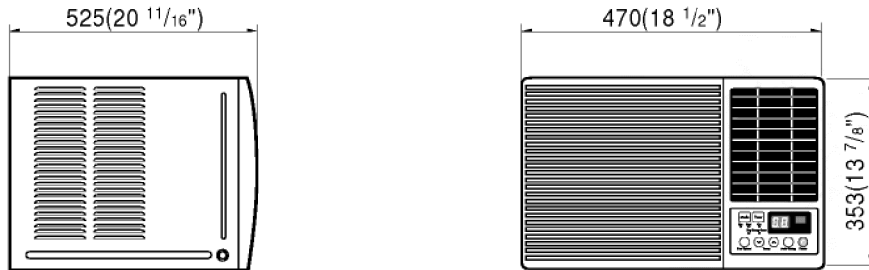

## 4.2 PIPING SYSTEM

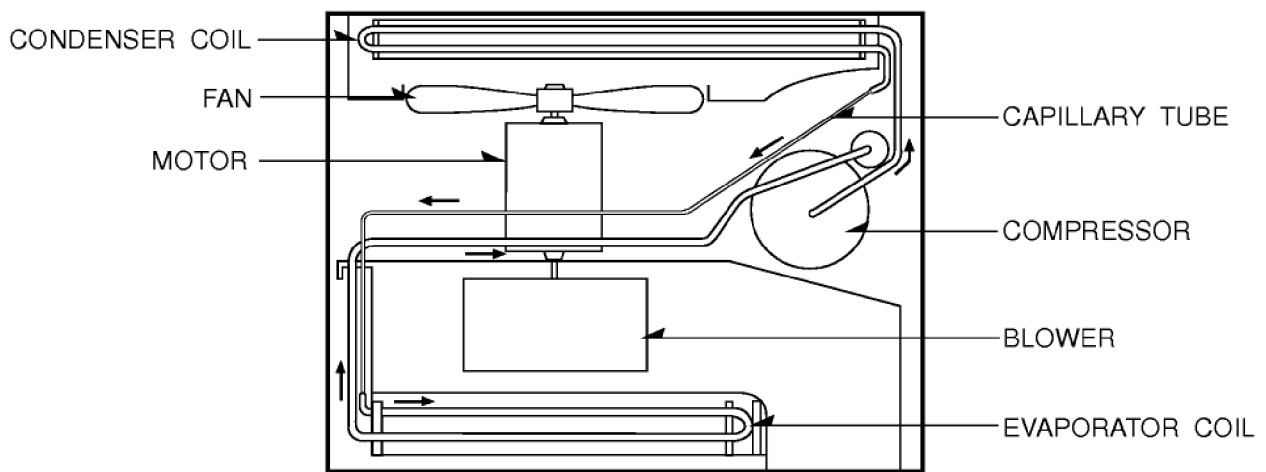

Following is a brief description of the important components and their function in what is called the refrigeration system. Reference should be made to Figure 34 to follow the refrigeration cycle and the flow of the refrigerant in the cooling cycle.

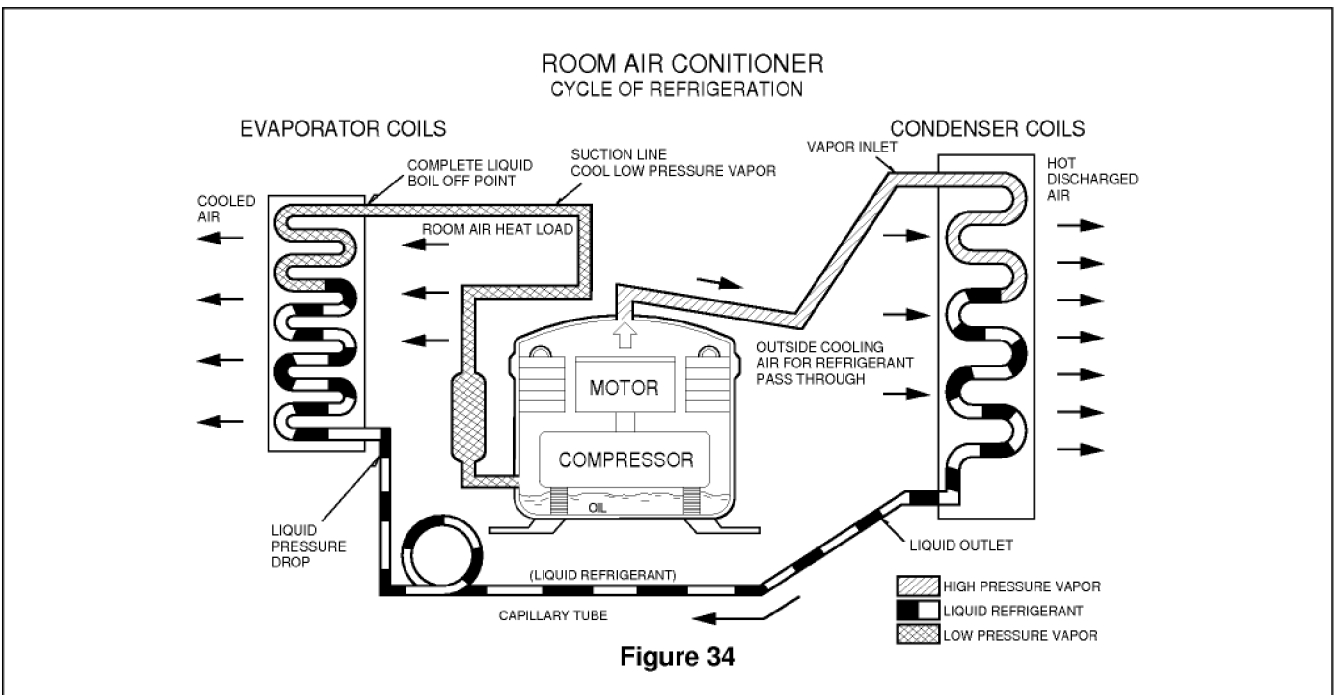

### 4.3 TROUBLESHOOTING GUIDE

In general, possible trouble is classified in two kinds.

The one is called Starting Failure which is caused from an electrical defect, and the other is ineffective Air Conditioning caused by a defect in the refrigeration circuit and improper application.

#### Unit runs but poor cooling.

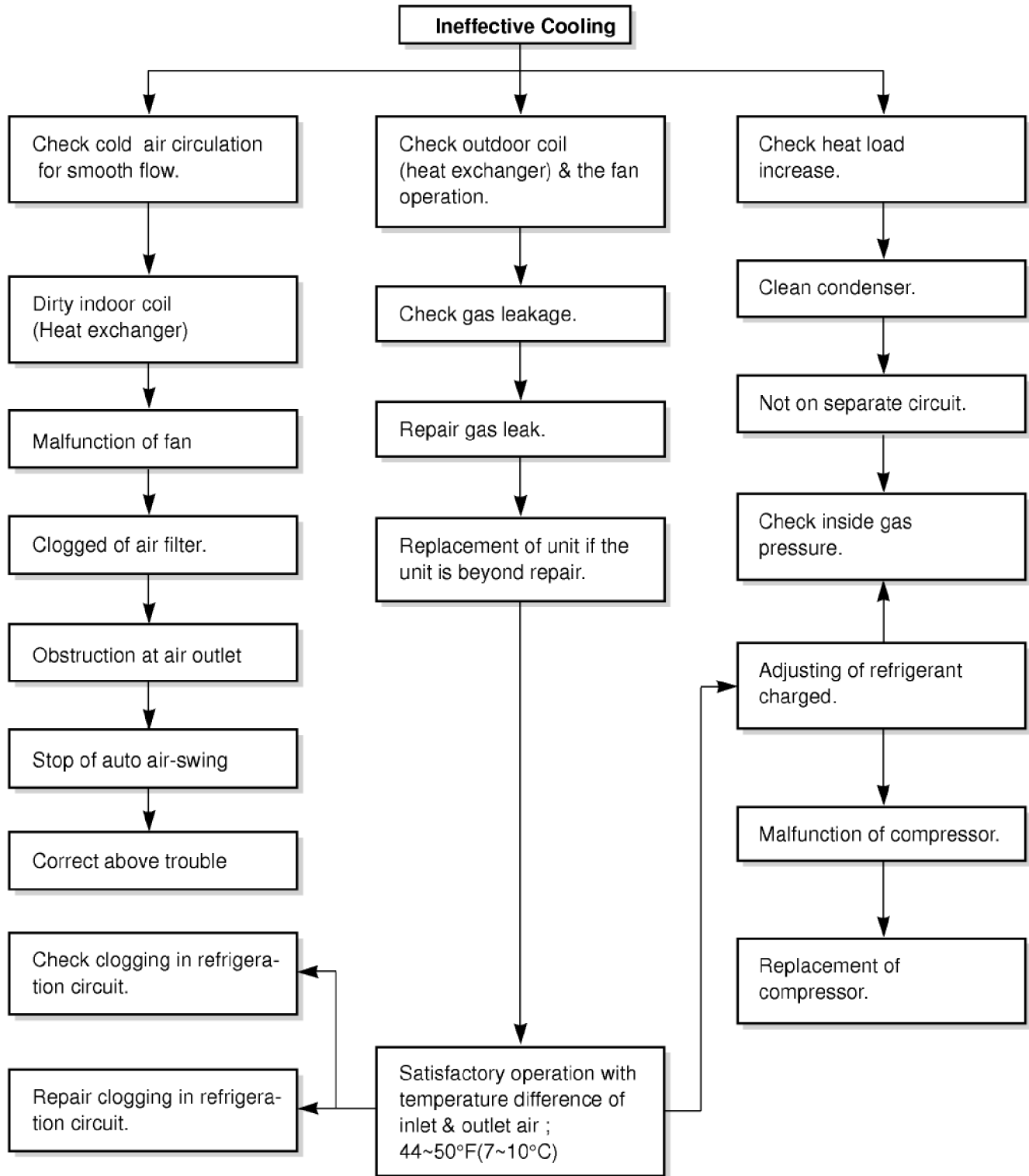

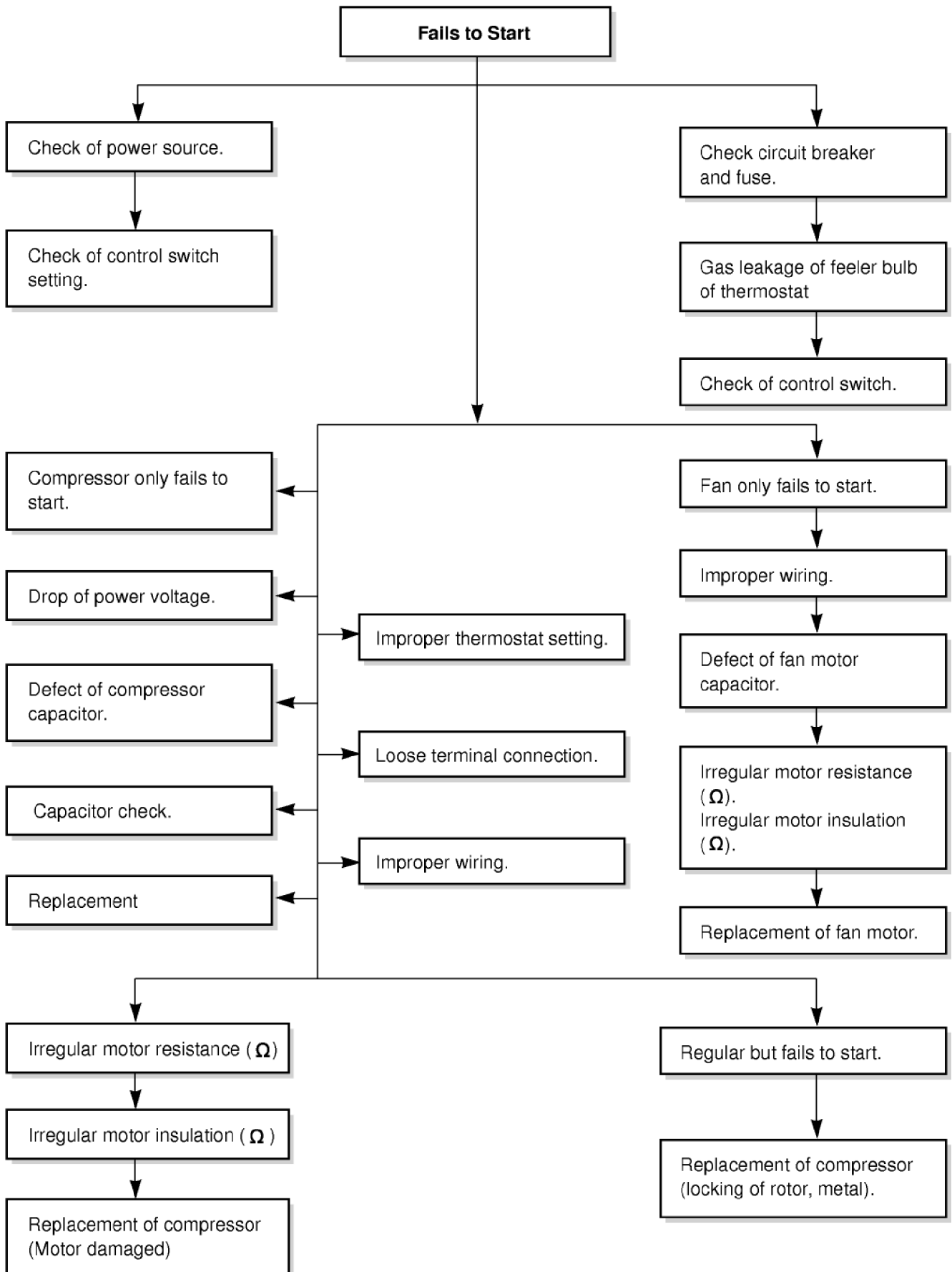

## ■ ELECTRICAL PARTS TROUBLESHOOTING GUIDE: M8000R, M-8000

### Possible Trouble 1

The unit does not operate.

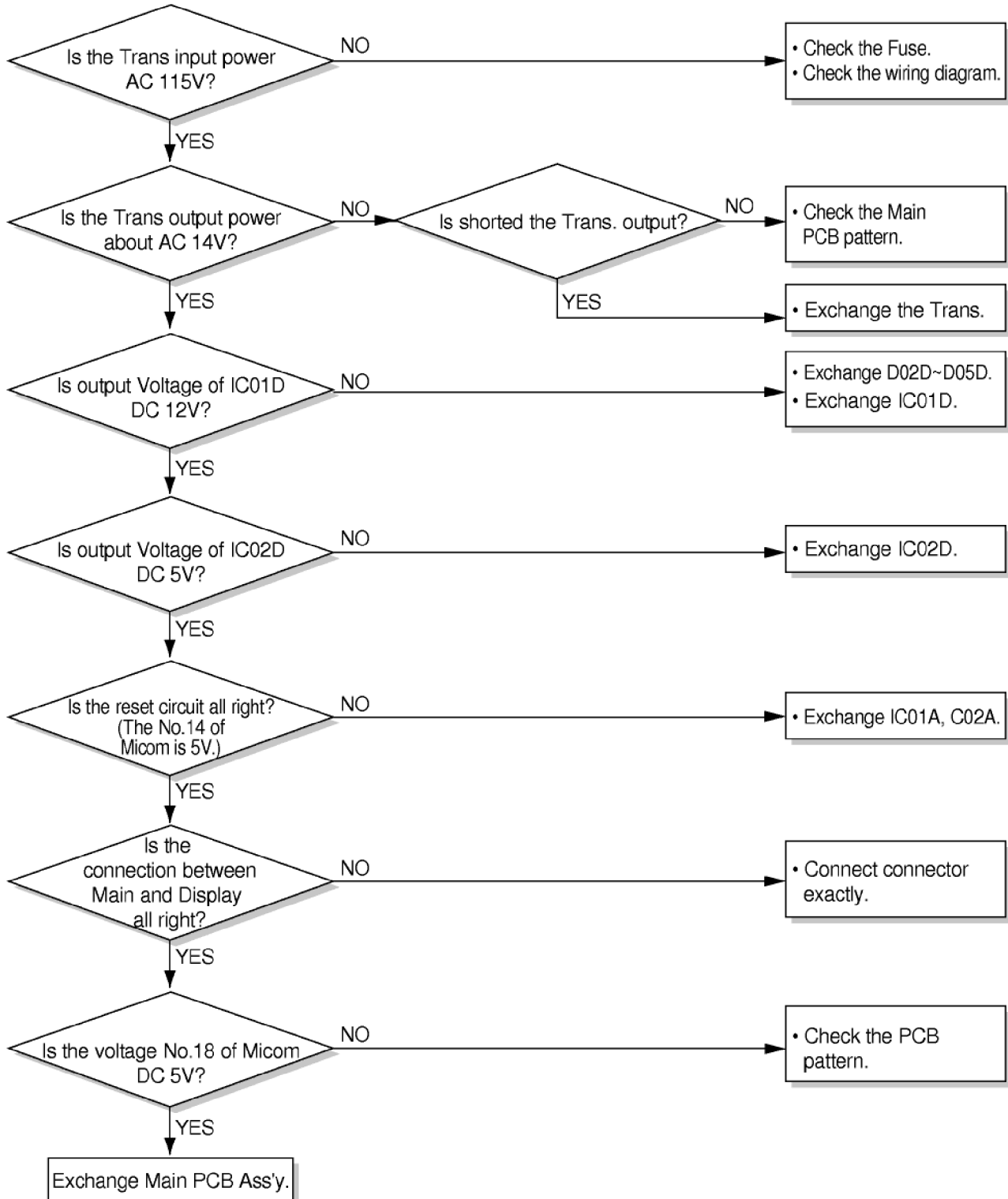

**Possible Trouble 2**

The compressor does not operate.

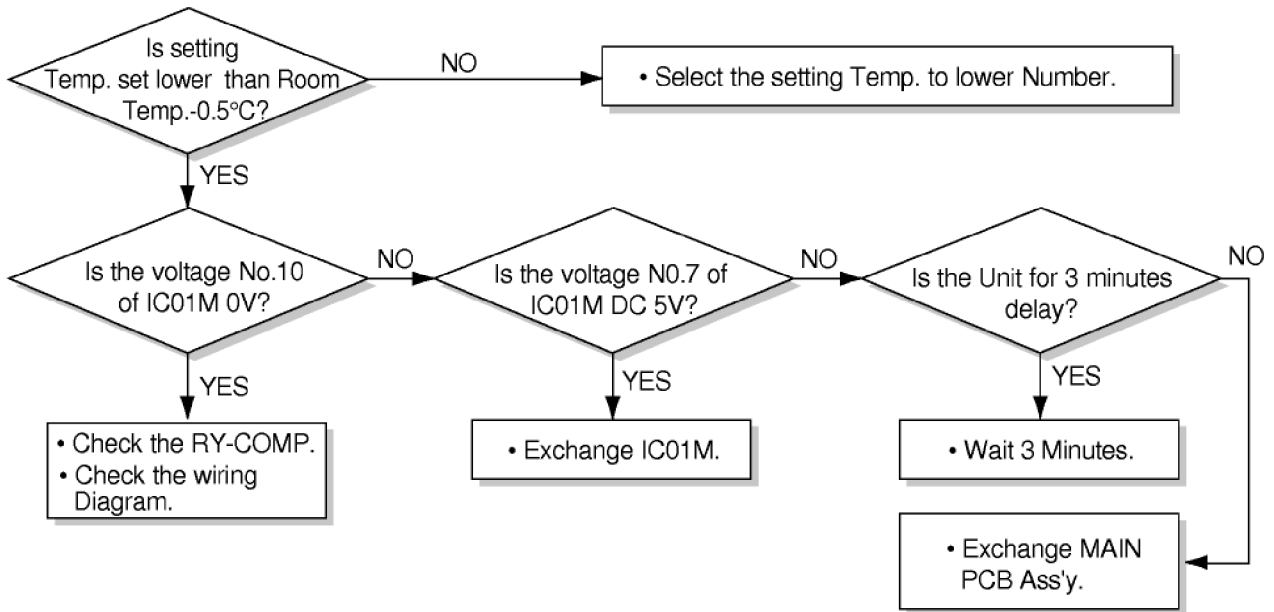

**Possible Trouble 3**

The compressor always operate.



**Possible Trouble 4**

FAN does not operate.

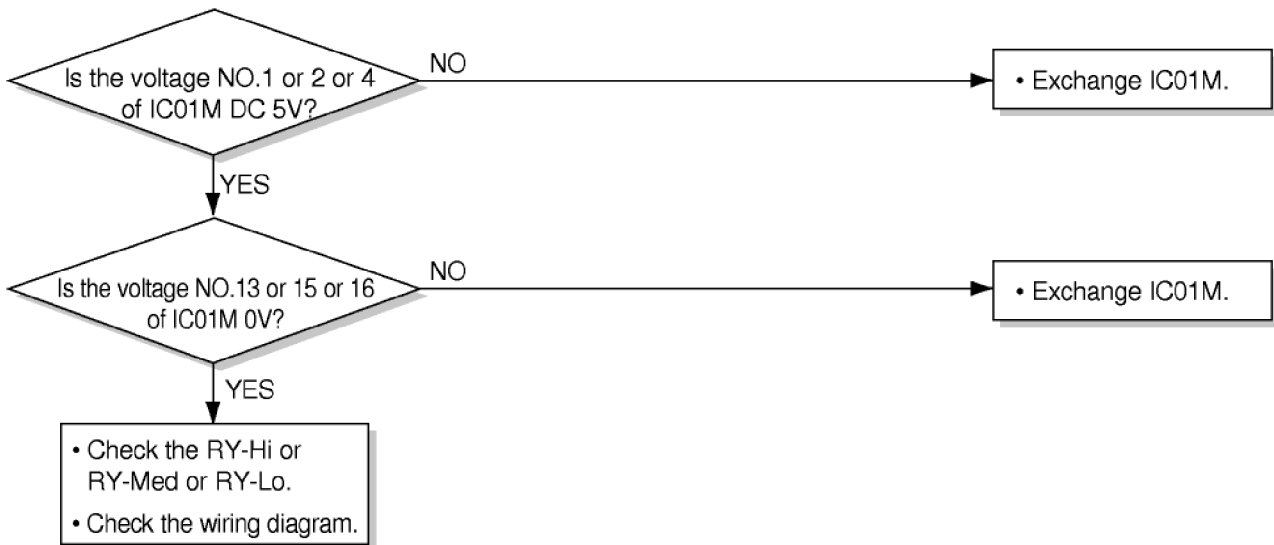
**Possible Trouble 5**

The function of Energy Saver does not operate.

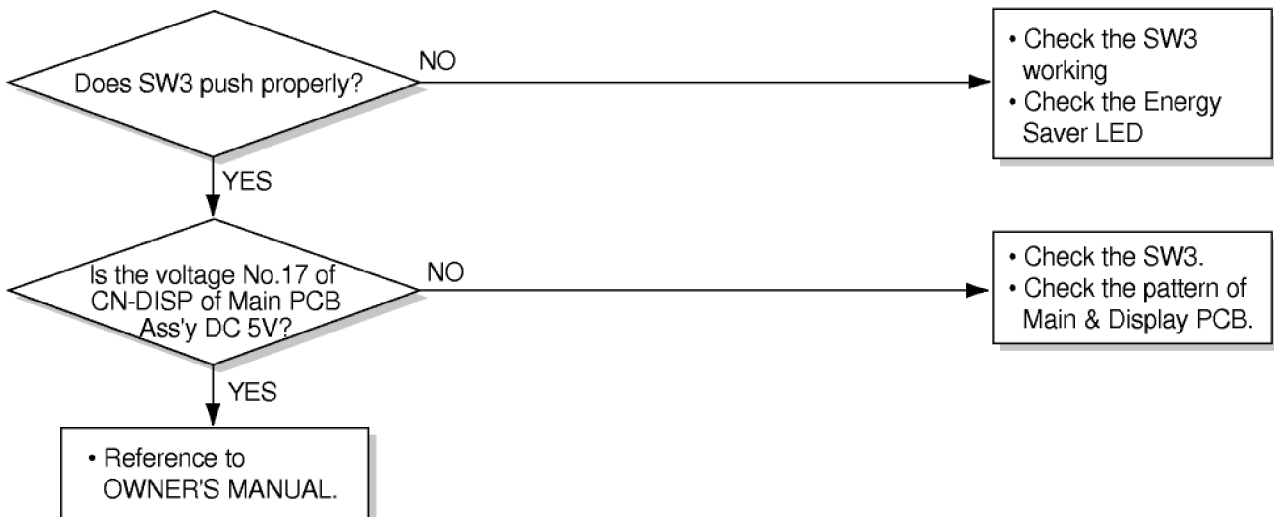

**Possible Trouble 6**

Remote controller does not operate.

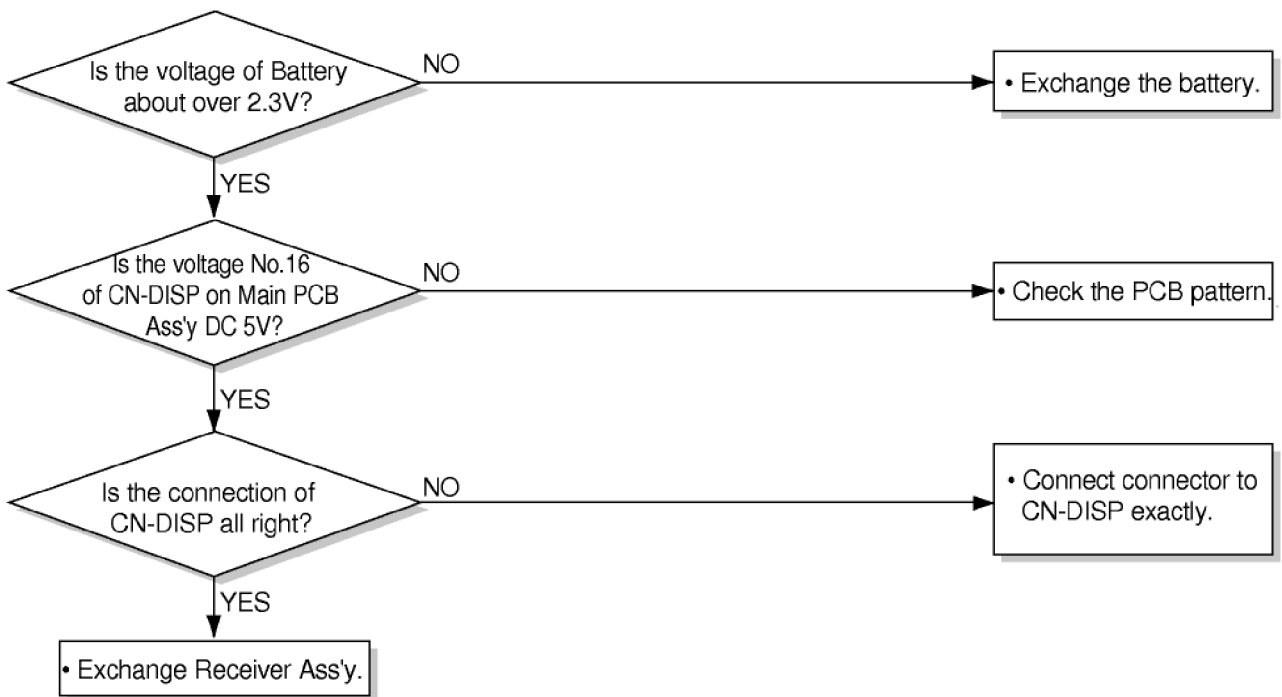
**Possible Trouble 7**

It displays abnormally on display PCB Ass'y.

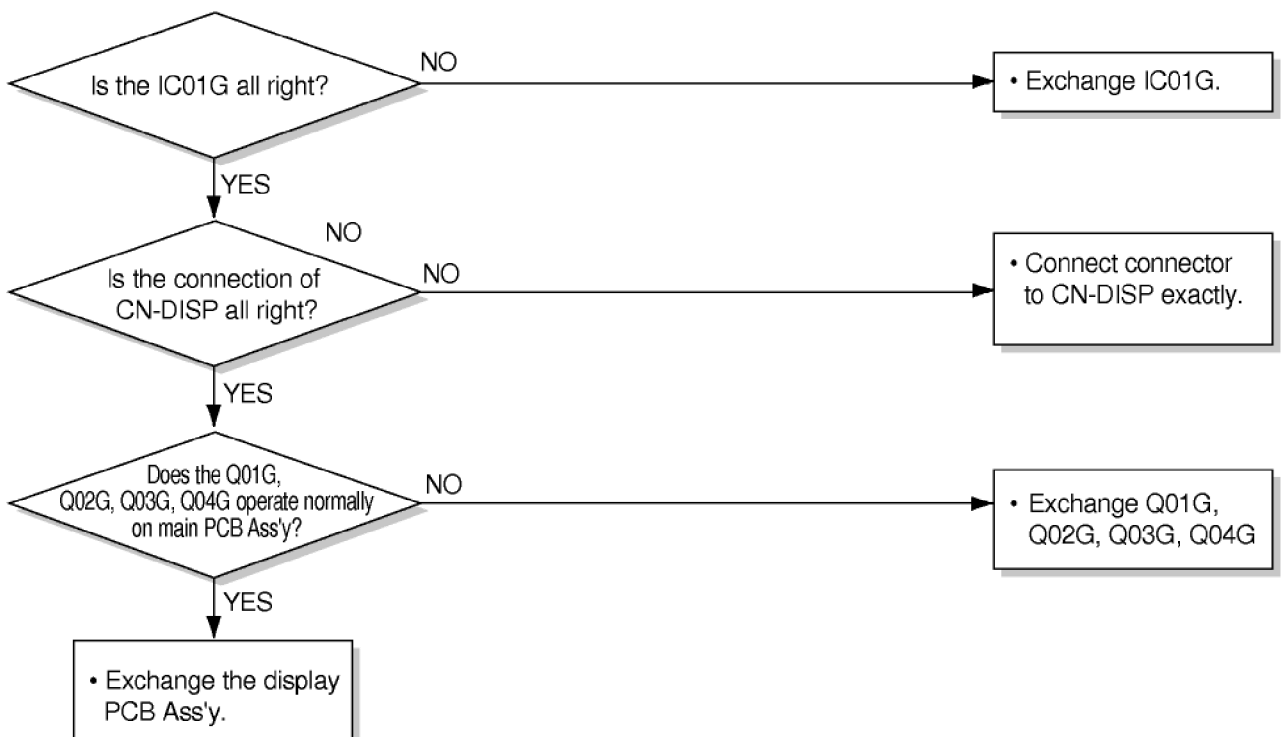

## ROOM AIR CONDITIONER VOLTAGE LIMITS

NAME PLATE RATING	MINIMUM	MAXIMUM
115V ± 10%	103.5V	126.5V

COMPLAINT	CAUSE	REMEDY
Fan motor will not run.	No power	Check voltage at outlet. Correct if none.
	Power supply cord	Check voltage to rotary switch. If none, check power supply cord. Replace cord if circuit is open.
	Rotary switch	Check switch continuity. Refer to wiring diagram for terminal identification. Replace switch if defective.
	Wire disconnected or connection loose	Connect wire. Refer to wiring diagram for terminal identification. Repair or replace loose terminal.
	Capacitor (Discharge capacitor before testing.)	Test capacitor. Replace if not within ±10% of manufacturer's rating. Replace if shorted, open, or damaged.
	Will not rotate	Fan blade hitting shroud or blower wheel hitting scroll. Realign assembly.  Units using slinger ring for condenser fan must have 1/4 to 5/16 inch clearance to the base. If it hits the base, shim up the bottom of the fan motor with mounting screw(s).  Check fan motor bearings; if motor shaft will not rotate, replace the motor.
Fan motor runs intermittently	Revolves on overload.	Check voltage. If not within limits, call an electrician.
		Test capacitor. Check bearings. Does the fan blade rotate freely? If not, replace fan motor.
		Pay attention to any change from high speed to low speed. If the speed does not change, replace the motor.

COMPLAINT	CAUSE	REMEDY
Fan motor noise.	Fan	If cracked, out of balance, or partially missing, replace it.
	Blower	If cracked, out of balance, or partially missing, replace it.
	Loose clamper	Tighten it.
	Worn bearings	If knocking sounds continue when running or loose, replace the motor. If the motor hums or noise appears to be internal while running, replace motor.
Compressor will not run, but fan motor runs.	Voltage	Check voltage. See the limits on the preceding page. If not within limits, call an electrician.
	Wiring	Check the wire connections, if loose, repair or replace the terminal. If wires are off, refer to wiring diagram for identification, and replace. Check wire locations. If not per wiring diagram, correct.
	Rotary	Check for continuity, refer to the wiring diagram for terminal identification. Replace the switch if circuit is open.
	Thermostat	Check the position of knob. If not at the coldest setting, advance the knob to this setting and restart unit. Check continuity of the thermostat. Replace thermostat if circuit is open.
	Capacitor (Discharge capacitor before servicing.)	Check the capacitor. Replace if not within $\pm 10\%$ of manufacturer's rating. Replace if shorted, open, or damaged.
	Compressor  Overload	Check the compressor for open circuit or ground. If open or grounded, replace the compressor.  Check the compressor overload, if externally mounted. Replace if open. (If the compressor temperature is high, remove the overload, cool it, and retest.)
Compressor cycles on overload.	Voltage	Check the voltage. If not within limits, call an electrician.
	Overload	Check overload, if externally mounted. Replace if open. (If the compressor temperature is high, remove the overload, cool, and retest.)

<b>COMPLAINT</b>	<b>CAUSE</b>	<b>REMEDY</b>
Compressor cycles on overload(Cont'd)	Fan motor	If not running, determine the cause. Replace if required.
	Condenser air flow restriction	Remove the cabinet. inspect the interior surface of the condenser; if restricted, clean carefully with a vacuum cleaner (do not damage fins) or brush. Clean the interior base before reassembling.
	Condenser fins (damaged)	If condenser fins are closed over a large area on the coil surface, head pressures will increase, causing the compressor to overload. Straighten the fins or replace the coil.
	Capacitor	Test capacitor.
	Wiring	Check the terminals. If loose, repair or replace.
	Refrigerating system	Check the system for a restriction.
Insufficient cooling	Air filter	If restricted, clean or replace.
	Exhaust damper door	Close if open.
	Unit undersized	Determine if the unit is properly sized for the area to be cooled.
Excessive noise.	Blower or fan	Check the set screw or clamp. If loose or missing, correct. If the blower or fan is hitting air guide, rearrange the air handling parts.
	Copper tubing	Remove the cabinet carefully and rearrange tubing not to contact cabinet, compressor, shroud, and barrier.

# 5. SCHEMATIC DIAGRAM

## 5.1 CIRCUIT DIAGRAM

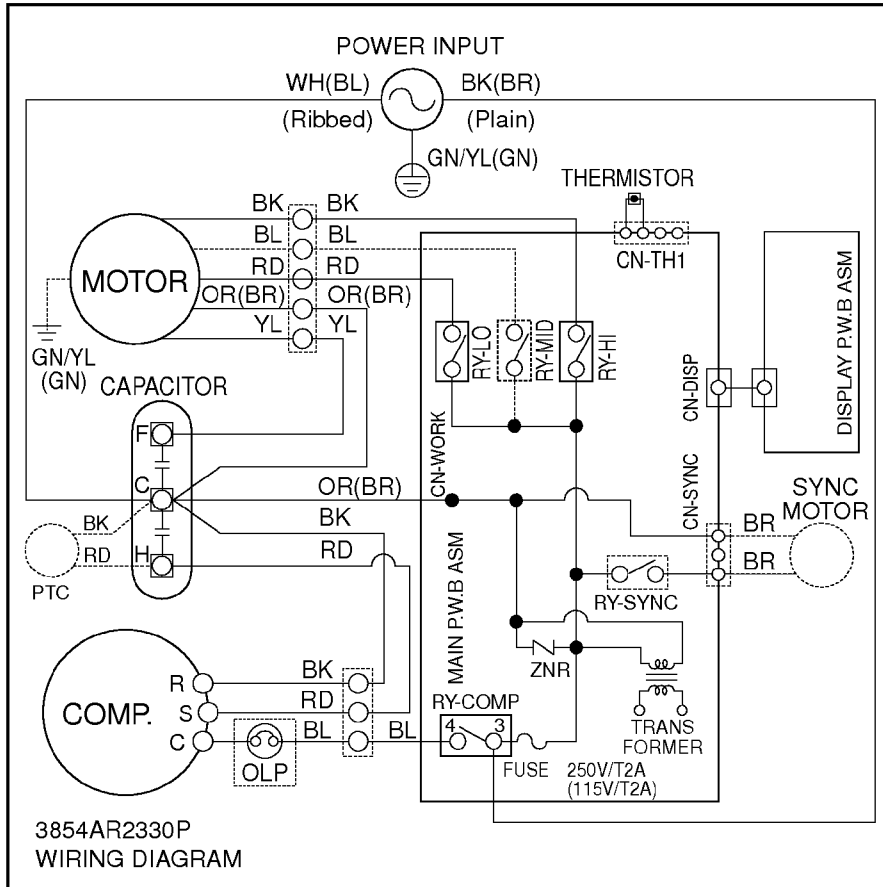



### 5.3 COMPONENTS LOCATION(OF MAIN P.C.B ASM)

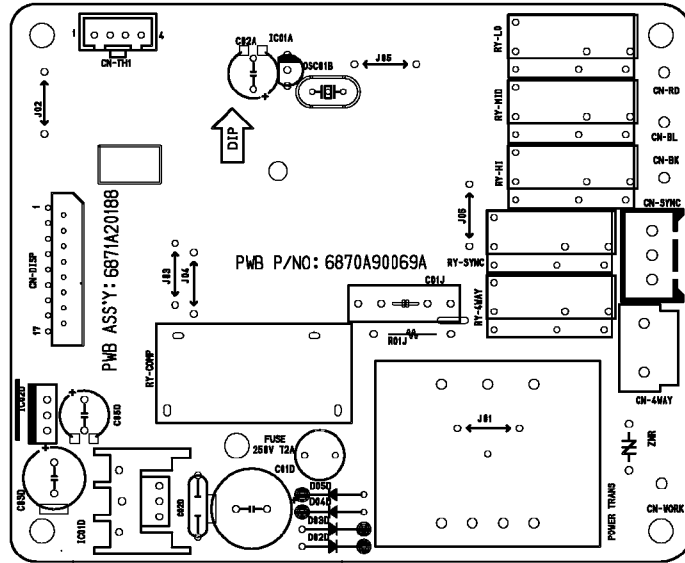

### 5.4 COMPONENTS LOCATION(OF DISPLAY P.C.B ASM)

• 8K, 10K Btu

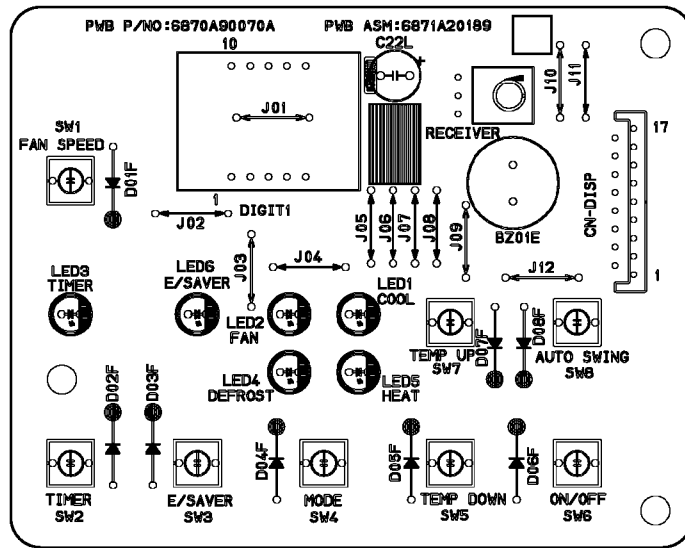

• 12K Btu

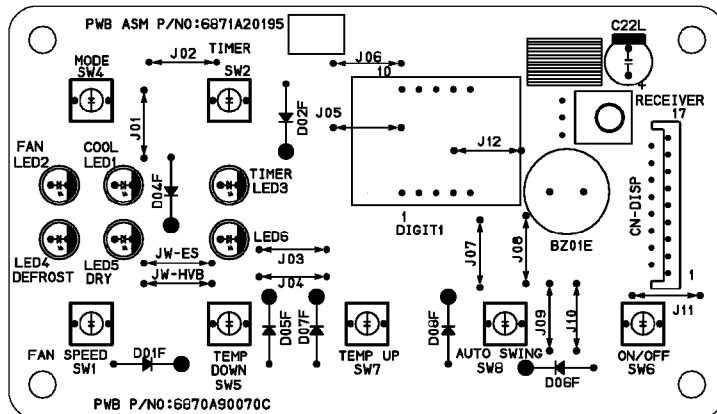

# 6. EXPLODED VIEW

