

The Sears logo is displayed in a stylized, bold, italicized font within a rectangular border.

MODEL	721.62362
	721.62364
	721.62365
	721.62369

DIVISION 20

BASIC FIELD MANUAL

FOR

ULTRA WAVE™

MICROWAVE OVEN

MODEL 721.62362
721.62364
721.62365
721.62369

January, 2003

CAUTION

WARNING TO SERVICE TECHNICIANS

PRECAUTIONS TO BE OBSERVED BEFORE AND DURING SERVICING TO AVOID POSSIBLE EXPOSURE TO EXCESSIVE MICROWAVE ENERGY

- a. Do not operate or allow the oven to be operated with the door open.
- b. Make the following safety checks on all ovens to be serviced before activating the magnetron or other microwave source, and make repairs as necessary; (1) Interlock operation, (2) proper door closing, (3) seal and sealing surfaces (arcing, wear, and other damage), (4) damage to or loosening of hinges and latches, (5) evidence of dropping or abuse.
- c. Before turning on microwave for any service test or inspection within the microwave generating compartments, check the magnetron, wave guide or transmission line, and cavity for proper alignment, integrity, and connections.
- d. Any defective or misadjusted components in the interlock, monitor, door seal, and microwave generation and transmission systems shall be repaired adjusted by procedures described in this manual before the oven is released to the owner.
- e. A Microwave leakage check to verify compliance with the Federal performance standard should be performed on each oven prior to release to the owner.
 - Proper operation of the microwave ovens requires that the magnetron be assembled to the wave guide and cavity. Never operate the magnetron unless it is properly installed.
 - Be sure that the magnetron gasket is properly installed around the dome of the tube whenever installing the magnetron.
 - Routine service safety procedures should be exercised at all times.
 - Untrained personnel should not attempt service without a thorough review of the test procedures and safety information contained in this manual.

FOREWORD

Read this Manual carefully. Failure to adhere to or observe the information in this Manual may result in exposing yourself to the Microwave Energy normally contained within the oven cavity.

MODEL 721.62362 721.62364 721.62365 721.62369

MECHANICAL SERVICE INFORMATION

TABLE OF CONTENTS

1. Adjustment Procedures	3
2. Precautions on Installation	5
3. General Precautions in Use	5
4. Trial Operation	5
5. Features and Specifications	5
6. Overall Circuit Diagram	7-8
7. Operating Procedures	9-11
8. Procedure for Measuring Microwave Energy Leakage	12-13
9. Disassembly Instructions	14-18
10. Interlock Continuity Test	19
11. Test and Checkout Procedures, and Troubleshooting	
A. Test Procedures	20-22
B. Checkout Procedures	23-25
C. Troubleshooting	26-30

1. ADJUSTMENT PROCEDURES

To avoid possible exposure to microwave energy leakage, adjust the door latches and interlock switches, using the following procedure.

ONLY AUTHORIZED SERVICE PERSONNEL SHOULD MAKE THIS ADJUSTMENT.

The Interlock Monitor and Primary Interlock Switch acts as the final safety switch protecting the user from microwave energy. The terminals between "COM" and "NC" of the Interlock Monitor must close when the door is opened. After adjusting the Interlock Monitor Switch, make sure that it is correctly connected. See Figures 1-a and 1-b throughout this procedure.

CHECK THE DOOR LATCH AND SWITCH CLOSINGS.

NOTE: The out case of the microwave oven is removed.

- (1) Set the microwave oven on its side so that you can see the latch board and the switches, as shown in Figure 1-a.
- (2) Close the door tightly and check gaps A and B to be sure they are no more than 1/64" (0.5 mm). See Figure 1-b for close-up view of gaps A and B (door latches). If all gaps are less than 1/64" (0.5 mm), adjustment of the latch board may not be necessary. Go to Steps 5 and 6 to check the sequence of the switches.

NOTE: To correct sequence of the Primary Interlock Switch, Secondary Interlock Switch and the Interlock Monitor Switch is very important.

If any gap is larger than 1/64" (0.5 mm), you will need to adjust the latch board-U, L. Go to step 3 and follow all steps in order.

ADJUST THE LATCH AND SWITCH CLOSINGS

- (3) Loosen the screw holding the plastic latch board as shown.
- (4) With the oven door closed tightly, move the latch board upward toward the top of the oven and/or away from the door latch until the gaps are less than 1/64" (0.5 mm).

Hold the latch board tightly in this position until you check the sequence of the switches in steps 5 and 6.

TEST THE LATCH AND SWITCH SEQUENCE

- (5) Open the oven door slowly. Watch the door latch, the Primary Switch. Release Rod and Lever on the switches to make sure they are zero to the body of the switches in the following sequence:
 - Primary Interlock Switch
 - Secondary Interlock Switch
 - Interlock Monitor Switch

Adjust the latch board until the switches operate in this sequence. See Steps 3 and 4.

- (6) Close the oven door slowly and be sure it is tightly closed. Watch the three switches to make sure they are zero to the body of the switches in the following sequence:
 - Interlock Monitor Switch
 - Primary Interlock Switch
 - Secondary Interlock Switch

NOTE: The Interlock Monitor Switch is an added safety check on the Primary and Secondary Interlock Switches. If the Primary and Secondary Interlock Switches allow the oven to operate with the door open, the Monitor Switch will blow the fuse.

- (7) When you achieve the proper sequence of switches in Steps 5 and 6, tighten the latch board screws at that point.

TEST THE MICROWAVE ENERGY LEAKAGE

- (8) Using a survey meter, make sure the microwave energy is below 5 mW/cm.sq.

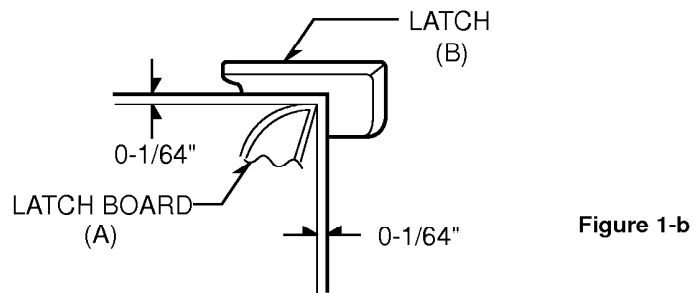
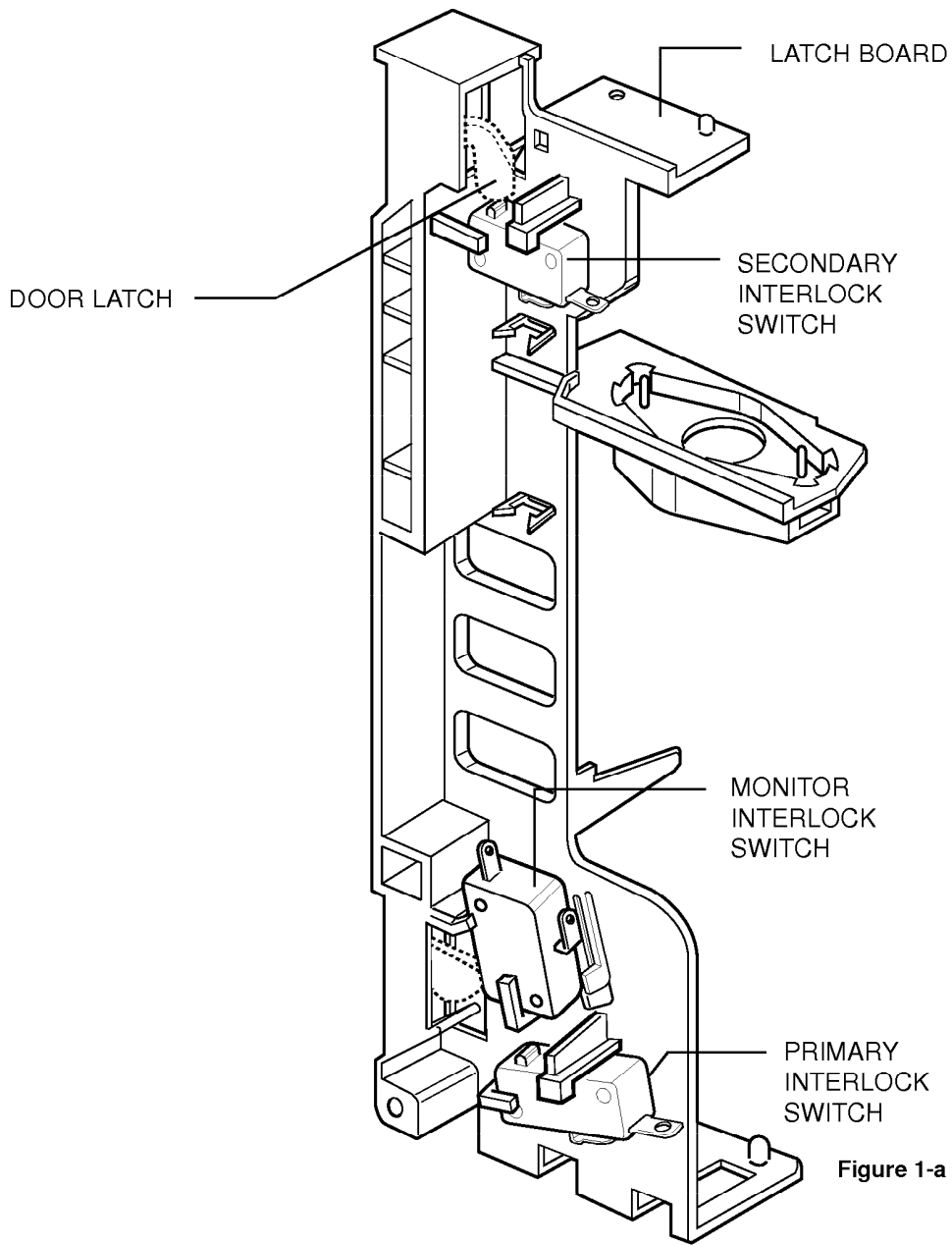

2. PRECAUTIONS ON INSTALLATION

(Figure 2)

- A. Plug the power supply cord into a 120 V AC, 60 Hz, single-phase power source with a capacity of at least 20 amperes.
- B. Since the unit weights about 38 lbs., be sure to place it on a sturdy and flat surface.
- C. Avoid placing the unit in a location where there is direct heat or splashing water.
- D. Place the unit as far away as possible from TV, radio, etc. to prevent interference.

CAUTION

This unit is equipped with a 3-prong plug for your safety. If the wall outlet is a grounded 3-hole type, the unit will be grounded automatically.

Properly Polarized and Grounded Outlet

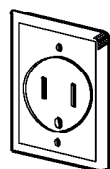
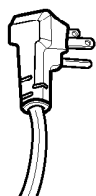

Three-Pronged(Grounding) Plug

Figure 2

3. GENERAL PRECAUTIONS IN USE

- A. Never operate the unit when it is empty. Operating the oven with no load may shorten the life of the magnetron. Whenever cooking dry foods (dried fish, bread, etc.) or a small amount of food, be sure to put a glass of water into the cooking compartment. The turntable tray may become hot after operating, be careful when touching it.
- B. Aluminum foil should be avoided because it will disrupt cooking and may cause arcing. However, small pieces may be used to cover some parts of food to slow the cooking. Any aluminum foil used should never be closer than 2.5 cm to any side wall of the oven.

4. TRIAL OPERATION

After installation, the following sequences and results should be checked carefully.

- A. Put a container filled with water (about 1 liter) into the oven, and close the door tightly.
- B. Touch the STOP/CLEAR and the COOK TIME keys. "0" appears in the display window.
- C. Set cooking time for 10 minutes by touching "1" and then "0" three times. "1000" appears in the display window.
- D. Touch the START key.
Make sure the cavity light comes on. The unit will begin cooking and the display window will show the time counting down by seconds.
- E. After about 5 minutes, make sure the primary interlock switch, the secondary interlock switch and the interlock monitor and oven lamp switch operate properly by opening and closing the door several times. Touch the START key each time the door is closed.
- F. Continue operating the unit. Two short and a long beep sound signal is heard when the time is up. The unit will shut off automatically.
- G. Confirm the water is hot.
- H. Finally, measure the output power according to "POWER OUTPUT MEASUREMENT" on page 13.

5. FEATURES AND SPECIFICATIONS

- A. The safety systems incorporated in this model are:
 - (1) Primary interlock switch
 - (2) Secondary interlock switch
 - (3) Interlock monitor switch
 - (4) Choke system
 - (5) Oven cavity thermostat
(Note: This thermostat located on the oven cavity will open and stop the unit from operation only if a high temperature is reached, such as, a fire created by overcooking food.)
- B. Any one of 10 power output levels ranging 0W to 1200W can be selected by the touch control and electronic computer system.
- C. Cooking time can be displayed on the digital readout.
- D. Three different cooking stages (Include Defrost) can be set. The oven remembers three cooking stages and changes from one cooking stage to another. This is made possible with the memory function of the microprocessor.

SPECIFICATIONS

Rated Power Consumption	1250W maximum
Output	1200W maximum (*IEC 60705 Rating standard) Adjustable 0W through 1200W, 10 steps
Frequency	2,450 MHz ± 50 MHz
Power Supply	120V ± 12V AC, 60Hz
Rated Current	11 Amp.
Magnetron Cooling	Forced Air Cooling
Microwave Stirring	Turntable
Rectification	Rectification Voltage Doubler Half-Wave (Inverter type)
Door Sealing	Choke System
Safety Devices	Thermostat: Open at 90 °C ± 5 °C Close at 75 °C ± 5 °C Fuse(20A) Primary Interlock Switch Secondary Interlock Switch Interlock Monitor
Magnetron	2M261
Cavity Lamp	125V, 20W
Timer	Digital, up to 99 mm. 99 sec. (in each cooking stage)
Tray	Tempered Safety Glass
Overall Dimensions	20 ³ / ₄ " (W) x 15 ¹ / ₄ " (D) x 19 ¹ / ₄ " (H)
Oven Cavity Size	17 ¹ / ₄ " (W) x 9" (D) x 16 ³ / ₄ " (H)
Effective Capacity of Oven Cavity	1.4 Cu.ft.
Accessories	Use and Care Manual , Turntable, Rotating Ring Assembly.

SWITCH CHART

SWITCH MODE	PRIMARY INTERLOCK SWITCH	SECONDARY INTERLOCK SWITCH	INTERLOCK MONITOR SWITCH
CONDITIONS	COM NO	COM NO	COM NC
DOOR OPEN	∞	∞	0
DOOR CLOSED	0	0	∞

NOTE: Use the above switch chart with circuit diagram on page 7.

6. OVERALL CIRCUIT DIAGRAM
 A. SCHEMATIC DIAGRAM

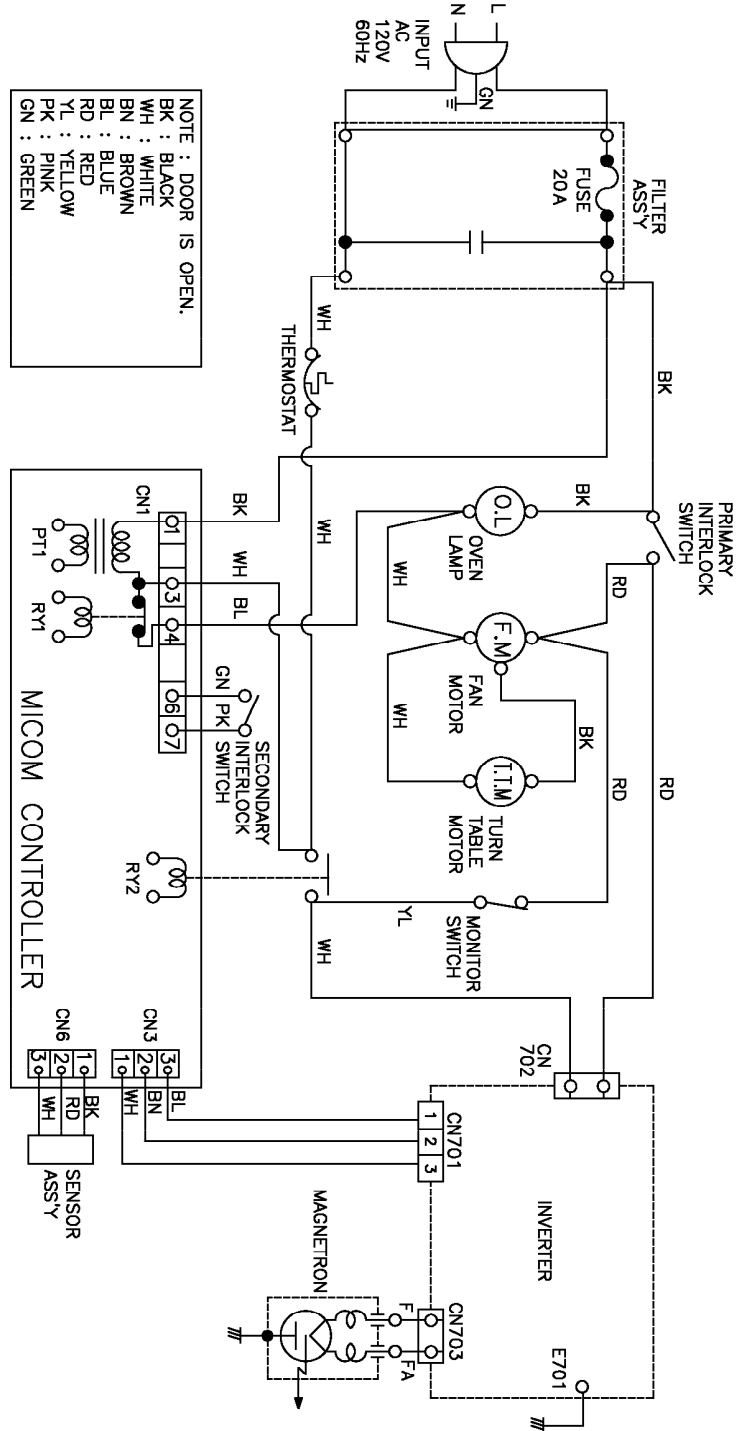

Figure 3

B. MATRIX CIRCUIT FOR TOUCH KEY BOARD

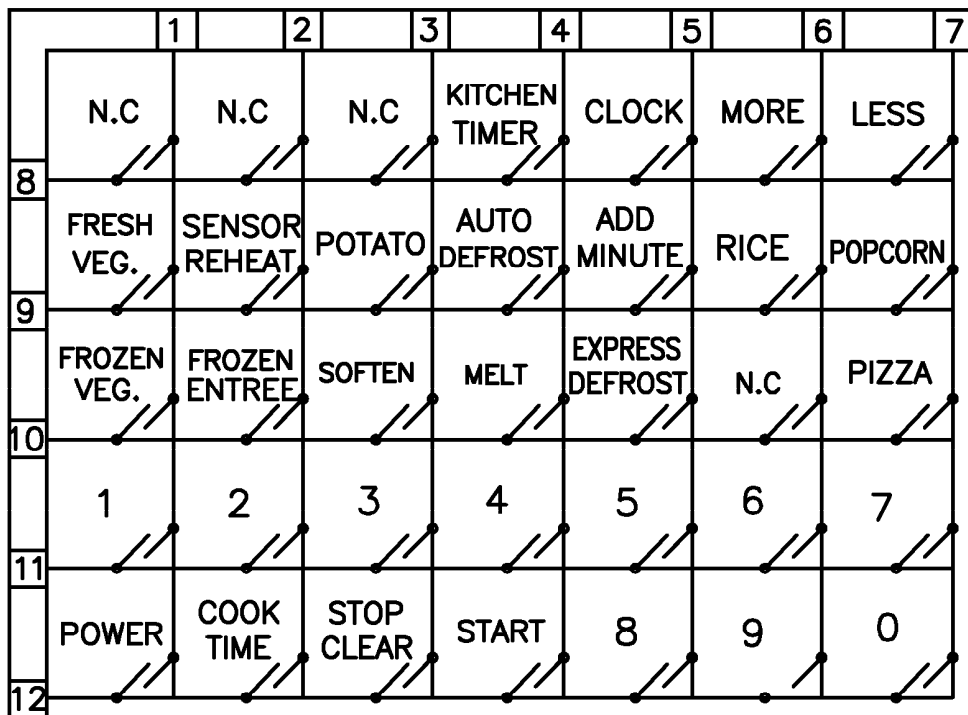

Figure 4

7. OPERATING PROCEDURES

A. OVEN CONTROL PANEL

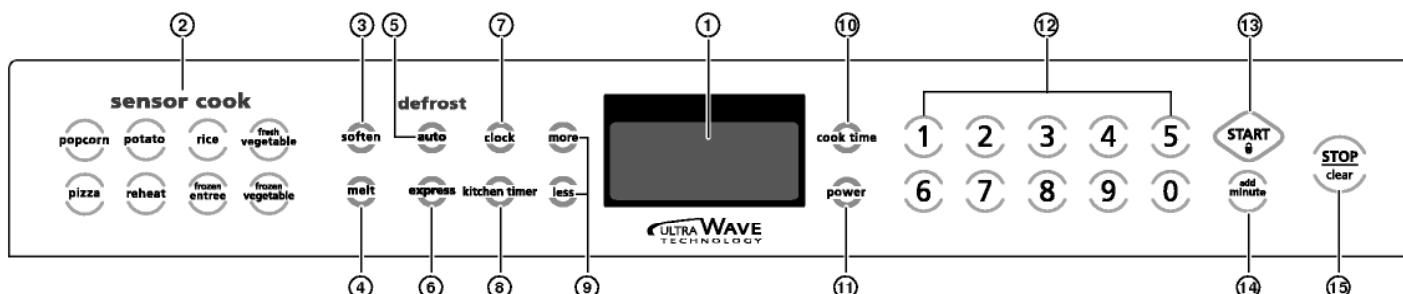

Figure 5

- 1. Display.** The Display includes a clock and indicators that tell you time of day, cooking time settings, and cooking functions selected.
- 2. Sensor Cook.** This pad allows you to cook most of your favorite foods without having to select cooking times and power levels.
- 3. Soften.** Touch this pad to soften ice cream, cream cheese, butter or frozen juice.
- 4. Melt.** Touch this pad to melt chocolate, cheese, butter or marshmallows.
- 5. Auto Defrost.** This pad is an accurate defrosting method for frozen meat, poultry and fish up to 6.0 lbs..
- 6. Express Defrost.** This pad provides you with the quick defrosting method for 1.0 lb. frozen ground beef.
- 7. Clock.** Touch this pad to enter the time of day.
- 8. Kitchen Timer.** Touch this pad to use your microwave oven as a kitchen timer.
- 9. More / Less.** Touch these pads to adjust cooking time in 10 second increments.
- 10. Cook time.** Touch this pad to set a cooking time.
- 11. Power.** Touch this pad to set a cooking power.
- 12. Number pads.** Touch Number pads to enter cooking time, Power level, quantities, or weights.
- 13. Start.** Touch this pad to start all entries (Except Sensor Cook, Express Defrost and Add Minute functions which start automatically). Also used to turn Child Lock on and off.
- 14. Add minute.** Touch this pad to cook for 1 minute to 99 minutes.
- 15. Stop/Clear.** Touch this pad to stop the oven or clear entries.

B. PANEL INSTRUCTIONS (Figure 5)

The entire operation is done by simple touch control pads.

(1) Display Window

Numbers and letters explained in Figure 5 are shown in the display window (Vacuum Fluorescent Tube).

- (a) The Time in four digits (12-hour indication): 00 Hour 00 Minute.
- (b) Cooking Time of Day in four digits 00 Minutes 00 Seconds.
- (c) Power Control Level in three digits: P-000
- (d) Each Indicator Light shows which function is set and involved in the course of cooking by turning itself on. Indicator Lights automatically go out upon completion of cooking.

(2) SENSOR COOK key

Use humidity sensor for certain food item.

(3) CLOCK Key

Used in setting Time of Day.

(4) COOK TIME Key

The TIME key is used to set the cooking time. Touch the TIME key and then the number keys that correspond to the desired cooking time. The remaining time is continuously displayed during cooking.

(5) STOP/CLEAR Key

Used to stop the oven or clear all entries except CLOCK.

(6) AUTO DEFROST key (DEFROST MEAT, POULTRY & FISH)

Used in setting AUTO DEFROST.

(7) EXPRESS DEFROST key

Used in setting EXPRESS DEFROST.

(8) KITCHEN TIMER Key

Used as a kitchen timer.

(9) POWER Key

Used to select cooking power level.

(10) ADD MINUTE Key

Used to cook for 1 minute to 99 minutes.

(11) START Key

Touch the START key after setting the desired cooking times etc. Also touch the START key to resume cooking after the cooking is temporarily stopped by opening the door. The key will not function unless the door is closed.

(12) Soften

Used to soften ice cream, cream cheese, butter or frozen juice.

(13) Melt

Used to melt chocolate cheese, butter or marshmallows.

(14) More/Less

Used to adjust cooking time in 10 second increments.

C. EASY USE CHART

(1) CLOCK

1. Touch STOP/CLEAR.
2. Touch CLOCK.
3. Touch numbers for correct time of day.
4. Touch CLOCK.

(2) "HI-POWER" COOKING

1. Touch STOP/CLEAR.
2. Touch COOK TIME.
3. Touch numbers for desired cooking time.
4. Touch START.

(3) "MULTI-STAGE" COOKING

1. Touch STOP/CLEAR.
2. Touch COOK TIME.
3. Touch numbers for cooking time.
4. Touch POWER.
5. Touch number for cooking power level.
6. Repeat steps 2-5 to set 2nd cooking stage.
7. Touch START.

(4) CHILD LOCK

To set:

1. Touch STOP/CLEAR.
2. Hold STOP/CLEAR more than 2 seconds.

To cancel:

1. Touch STOP/CLEAR.
2. Hold STOP/CLEAR more than 2 seconds.

(5) SOFTEN

1. Touch STOP/CLEAR.
2. Touch SOFTEN.
Four different soften menus are provided.
3. Select Menu 1 to 4- See cooking guide.
4. Enter the amount of the Category.

(6) MELT

1. Touch STOP/CLEAR.
2. Touch MELT.
Four different melt menus are provided.
3. Select Menu 1 to 4- See cooking guide.
4. Enter the amount of the Category.

(7) AUTO DEFROST

1. Touch STOP/CLEAR.
2. Touch AUTO DEFROST.
Three different defrosting category are provided.
(MEAT, POULTRY, FISH)
3. Enter the weight of your food in decimal increments from 0.1 to 6.0 pounds.
4. Touch START
5. At beeping, turn food over by following the instructions in the manual.
6. After turning food over, touch START to resume defrosting.

(8) EXPRESS DEFROST

1. Touch STOP/CLEAR.
2. Touch EXPRESS DEFROST.

(9) KITCHEN TIMER

1. Touch STOP/CLEAR.
2. Touch KITCHEN TIMER.
3. Touch correct numbers for time.
4. Touch START.

8. PROCEDURE FOR MEASURING MICROWAVE ENERGY LEAKAGE

A. CAUTIONS

- (1) Be sure to check a microwave emission prior to servicing the oven if the oven is operative prior to servicing.
- (2) The service personnel should inform the manufacturer, importer, or assembler of any certified oven unit found to have a microwave emission level in excess of 5mW/cm.sq. and should repair any unit found to have excessive emission levels at no cost to the owner and should ascertain the cause of the excessive leakage. The service personnel should instruct the owner not to use the unit until the oven has been brought into compliance.
- (3) If the oven operates with the door open, the service personnel should;
 - Tell the user not to operate the oven
 - Contact the manufacturer and CDRH (Center for Devices and Radiological Health) immediately.
NOTE: Address on CDRH
Office of Compliance (HFZ-312)
Center for Devices and Radiological Health
1390 Piccard Drive Rockville, Maryland 20850
- (4) The service personnel should check all surface and vent openings for microwave emission testing.
- (5) Check for microwave energy leakage after every servicing. The power density of the microwave radiation leakage emitted by the microwave oven should not exceed 1mW/cm.sq. And always start measuring of an unknown field to assure safety for operating personnel from radiation leakage.
NOTE: The standard is 5mW/cm.sq. while in the customer's home. 1mW/cm.sq. stated here is manufacturer's own voluntary standard for units in customer's home.

EQUIPMENT

- Electromagnetic energy leakage monitor (NARDA 8100B, HOLADAY HI 1501)
- 600cc glass beaker
- Glass thermometer 100°C

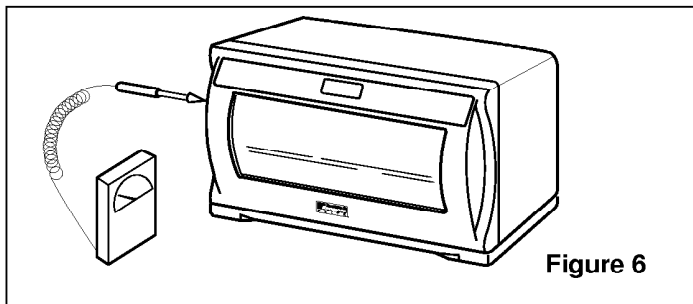

Figure 6

B. MEASURING MICROWAVE ENERGY LEAKAGE

- (1) Pour 275 ± 15cc of 20 ± 5 °C water in a beaker which is graduated to 600 cc, and place the beaker in the center of the oven.
- (2) Set the energy leakage monitor to 2,450 MHz and use it following the manufacturer's recommended test procedure to assure correct result.
- (3) When measuring the leakage, always use the 2 inch (5 cm) spacer supplied with the probe.
- (4) Operate the oven at its maximum output.
- (5) Measure the microwave radiation using an electromagnetic radiation monitor by holding the probe perpendicular to the surface being measured. (See Figure 7)

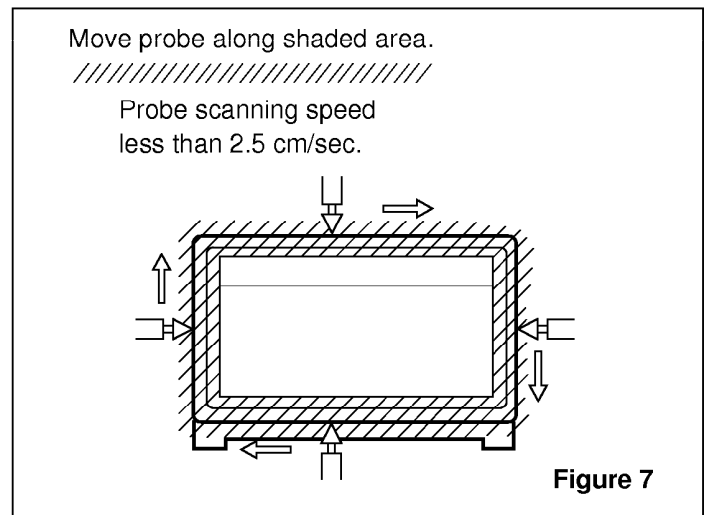

Figure 7

C. MEASUREMENT WITH THE OUT CASE REMOVED

- (1) When you replace the magnetron, measure for microwave energy leakage before the outer case is installed and after all necessary components are replaced or adjusted. Special care should be taken in measuring the following parts.
 - Around the magnetron
 - The waveguide

WARNING: AVOID CONTACTING ANY HIGH VOLTAGE PARTS.

D. MEASUREMENT WITH A FULLY ASSEMBLED OVEN

- (1) After all components, including the outer panels, are fully assembled, measure for microwave energy leakage around the door viewing window, the exhaust opening and air inlet openings.
- (2) Microwave energy leakage must not exceed the values prescribed below.

NOTES:

Leakage with the outer panels removed - less than 5mW/cm.sq. Leakage for a fully assembled oven (Before the latch switch (primary) is interrupted) with the door in a slightly opened position - less than 1 mW/cm .sq.

E. NOTE WHEN MEASURING

- (1) Do not exceed meter full scale deflection.
- (2) The test probe must be removed no faster than 1 inch/sec (2.5cm/sec) along the shaded area, otherwise a false reading may result.
- (3) The test probe must be held with the grip portion of the handle. A false reading may result if the operator's hand is between the handle and the probe.
- (4) When testing near a corner of the door, keep the probe perpendicular to the surface making sure the probe horizontally along the oven surface, this may possibly cause probe damage.

F. RECORD KEEPING AND NOTIFICATION AFTER MEASUREMENT

- (1) After adjustment and repair of any microwave energy interruption or microwave energy blocking device, record the measured values for future reference. Also enter the information on the service invoice.
- (2) Should the microwave energy leakage not be more than 1mW/cm.sq. after determining that all parts are in good condition, functioning properly and genuine replacement parts which are listed in this manual have been used.
- (3) At least once a year, have the electromagnetic energy leakage monitor checked for calibration by its manufacturer.

G. POWER OUTPUT MEASUREMENT

**Be sure oven cavity is clean and cool .
(not used recently)**

- (1) Fill the test beaker with 59 °F(15 °C) ~ 75 °F(24 °C) 1 liter tap water.
- (2) Stir the water in the beaker with thermometer (°F or °C) and measure temperature as T1.
- (3) Place the beaker on the center of turntable.
- (4) Set for one (1) minute.
- (5) When the heating is finished, stir the water again with thermometer and measure the temperature of water as T2.
- (6) Subtract T1 from T2, this will give you the temperature rise.
- (7) The microwave power output is within specification, if the temperature rise is as shown below:

Voltage (VAC under load)	Temperature Rise	
	°C	°F
120V	13 - 15	23.4 - 27
108V	11.5 - 13.5	20.7 - 24.3

- (8) Power output will be influenced by line voltage of power supply. Consequently, correct power output must be measured within 120V AC \pm 1 Volt while unit is operating.

SPECIAL TIP

- This oven used the button head screws.

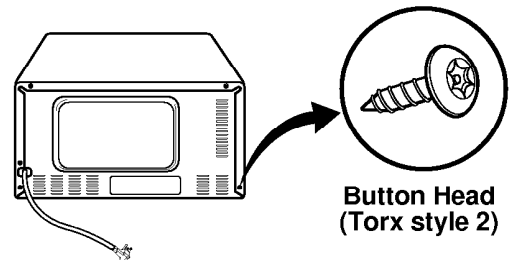

- When you remove the screws, using the tamper-resistant Torx driver have a pin-in-head.

9. DISASSEMBLY INSTRUCTIONS

IMPORTANT NOTES:

UNIT MUST BE DISCONNECTED FROM ELECTRICAL OUTLET WHEN MAKING REPAIRS, RE-PLACEMENTS, ADJUSTMENTS AND CONTINUITY CHECKS. WAIT AT LEAST ONE MINUTE, UNTIL THE HIGH VOLTAGE CAPACITOR IN THE HIGH VOLTAGE POWER SUPPLY HAS FULLY DISCHARGED.

THE CAPACITOR SHOULD BE DISCHARGED BY USING INSULATED WIRE - I.E. TEST PROBE CONNECTED TO 10K-OHM RESISTOR IN SERIES TO GROUND.

WHEN RECONNECTING THE WIRE LEADS TO ANY PART, MAKE SURE THE WIRING CONNECTIONS AND LEAD COLORS ARE CORRECTLY MATCHED ACCORDING TO THE OVERALL CIRCUIT DIAGRAM. (ESPECIALLY SWITCHES AND HIGH VOLTAGE CIRCUIT.)

A. REMOVING OUT CASE (Figure 8)

- (1) Unfasten five screws from the rear section.
- (2) Unfasten two screws from the side section.
- (3) Push the out case back about 1 inch (3cm).
- (4) Lift the case from the set.

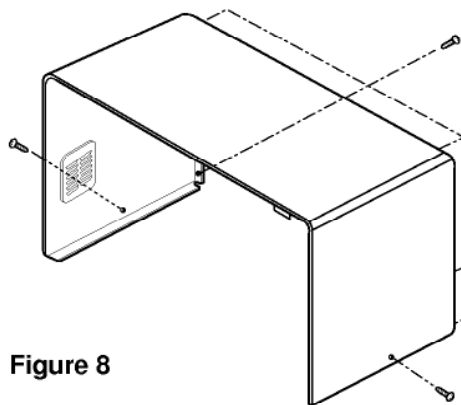

Figure 8

B. DOOR ASSEMBLY REMOVAL (Figure 9)

- (1) Remove out case.
- (2) Unfasten two screws for removing deco front.
- (3) Disconnect the lead wires from main board and pull that out from the cavity.
- (4) Remove the choke cap very carefully with a flat-blade screw driver.
- (5) Lift up and pull out Door assembly carefully from the cavity.

CAUTION: Be careful not to damage door seal plate with the screw driver.

Remove deco front

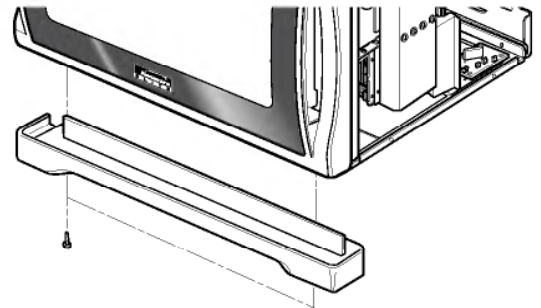

Disconnect the lead wires

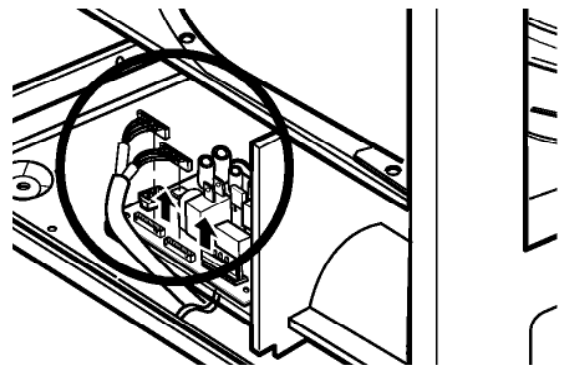

Remove choke cap

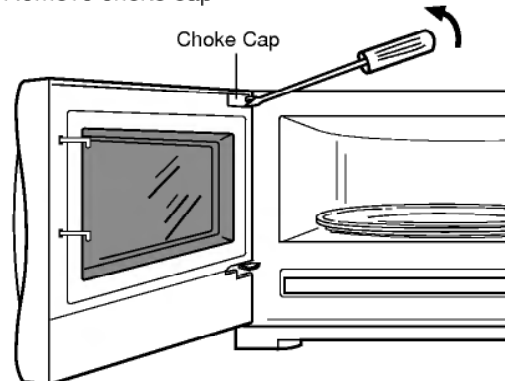

Remove door

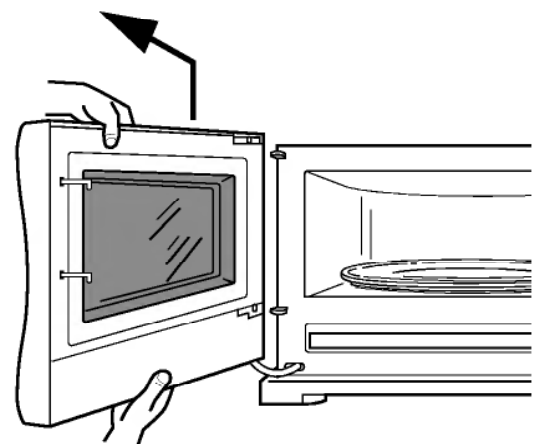
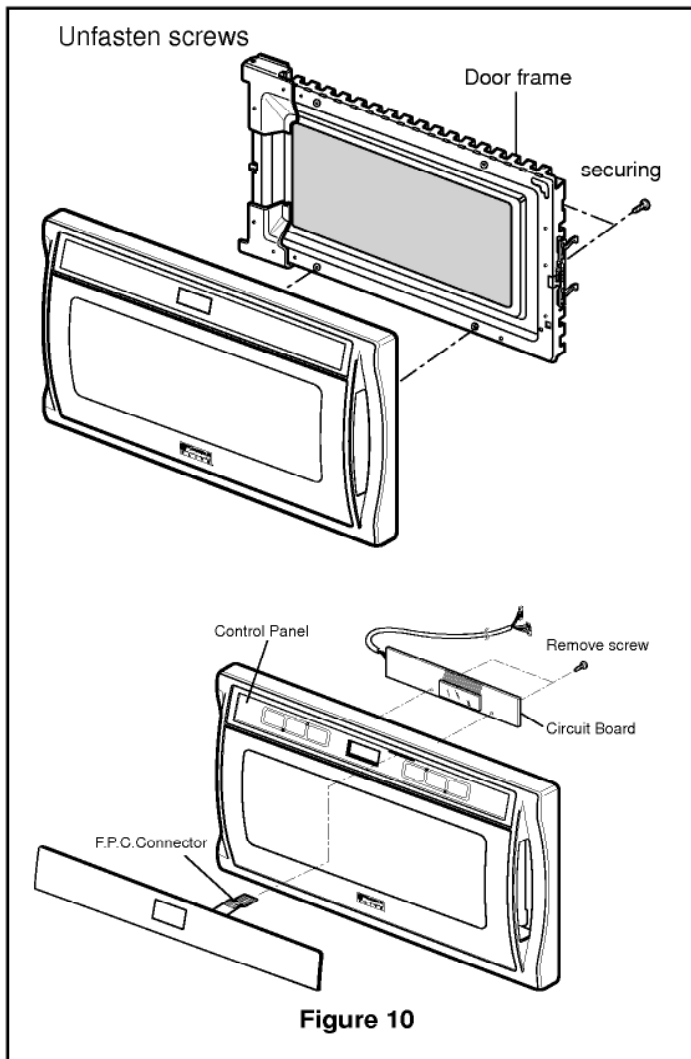

Figure 9

C. REMOVING CONTROL CIRCUIT BOARD (Figure 10)

- (1) Remove out case.
- (2) Remove door assembly.
- (3) Unfasten two screws.
- (4) Lift up and pull out control panel assembly carefully from the cavity.
- (5) Remove door frame.
- (6) Remove the F.P.C connector from the terminal socket.
- (7) Unfasten two screws which tighten the circuit board.
- (8) Remove control circuit board from the door panel assembly.



D. SEPARATE CAVITY AND BASE PLATE (Figure 11)

- (1) Remove out case.
- (2) Remove Door Assembly.
- (3) Remove five screws at the base plate.
(Front 3 EA, Back 2 EA).
- (4) Disconnect the lead wires from filter.
- (5) Disconnect all the lead wires from main board.
- (6) Disconnect the MGT high voltage lead wire and turn table motor lead wire.
- (7) Lift up the cavity and disconnect the fan motor lead wire.

CAUTION: BE CAREFUL NOT TO DAMAGE LEAD WIRE.

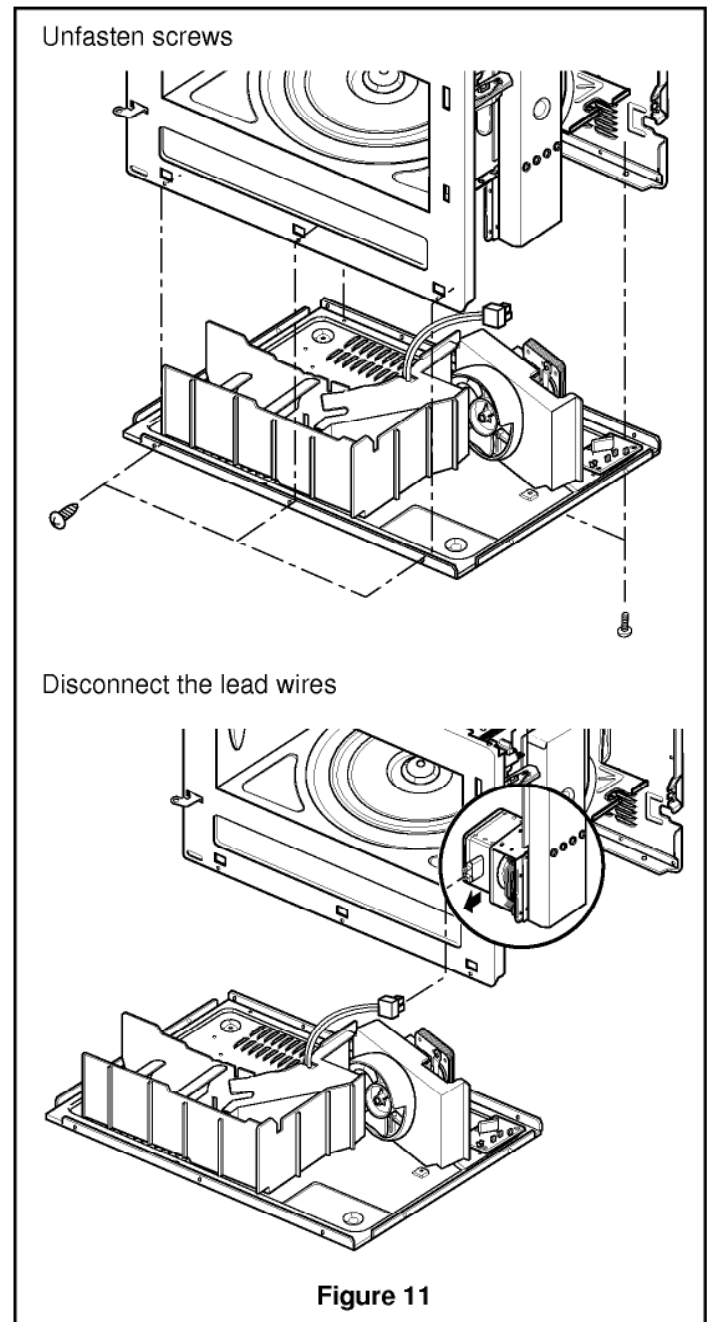

E. AIR GUIDE REMOVAL (Figure 12)

- (1) Separate cavity and base plate.
- (2) Unfasten the screws which hold the air guide in the base plate.
- (3) Unfasten the air guide from hook.

F. POWER BOARD AND INVERTER MODULE AND SUCTION GUIDE (Figure 12)

- (1) Separate cavity and base plate.
- (2) Remove air guide.
- (3) Unfasten the screws.
- (4) Lift up the power board, inverter module and suction guide.

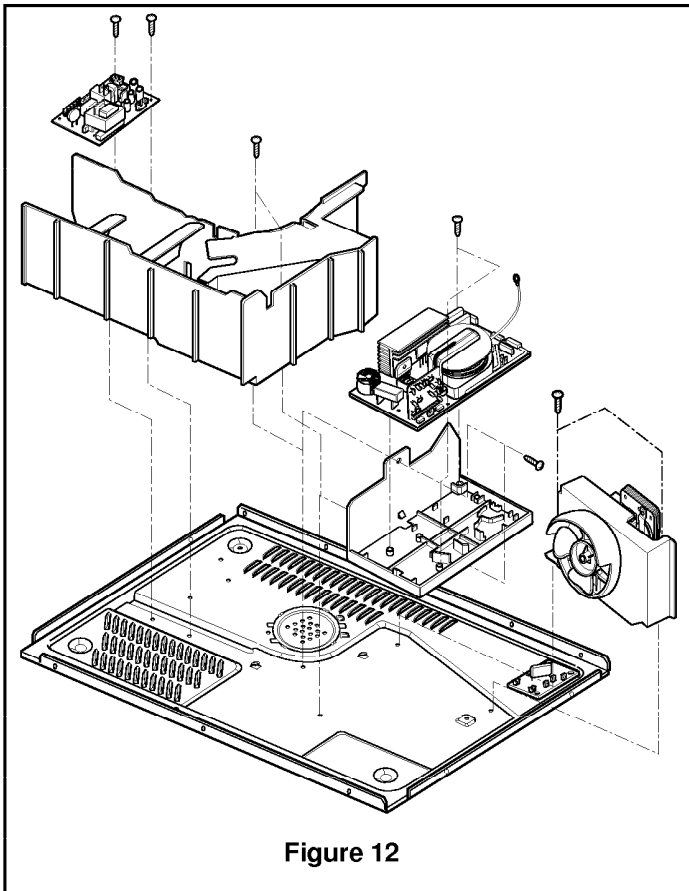

G. SENSOR DUCT REMOVAL (Figure 13)

- (1) Remove out case.
- (2) Unfasten the sensor duct screw.
- (3) Disconnect sensor lead wire.
- (4) Pull the sensor duct out.

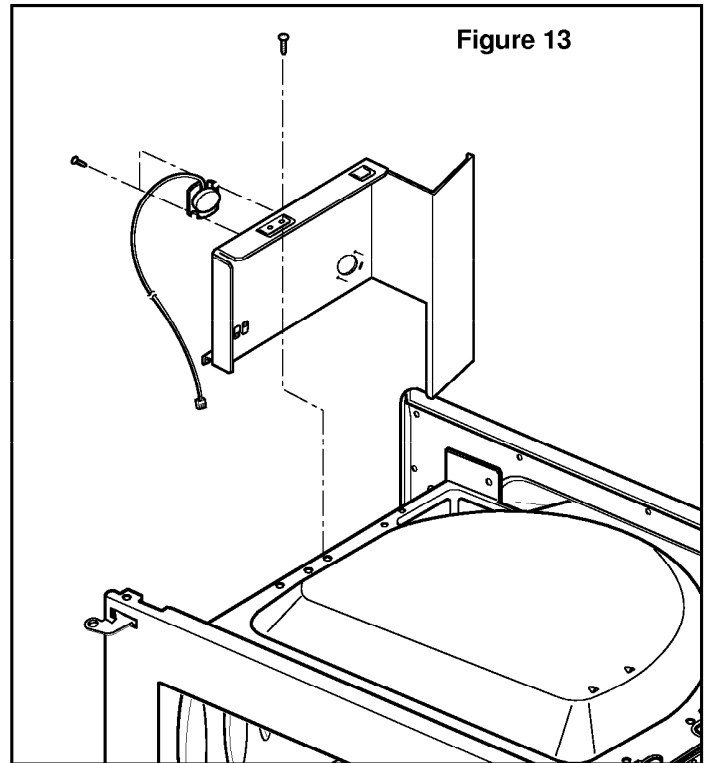

H. MAGNETRON REMOVAL

- (1) Disconnect the leadwire from the magnetron.
- (2) Carefully remove the mounting screws holding the magnetron at the waveguide.
- (3) Remove the magnetron from the waveguide.

NOTE:

1. When removing the magnetron, make sure its dome does not hit any adjacent parts, or it may be damaged.
2. When replacing the magnetron, be sure to install the magnetron gasket in the correct position and be sure that the gasket is in good condition.
3. After replacing the magnetron, check for microwave leakage with a survey meter around the magnetron. Microwave energy must be below the limit of 5 mW/cm². (With a 275 ml. water load).

Make sure that gasket is rigidly attached to the magnetron. To prevent microwave leakage, tighten the mounting screws properly, making sure there is no gap between the waveguide and the magnetron.

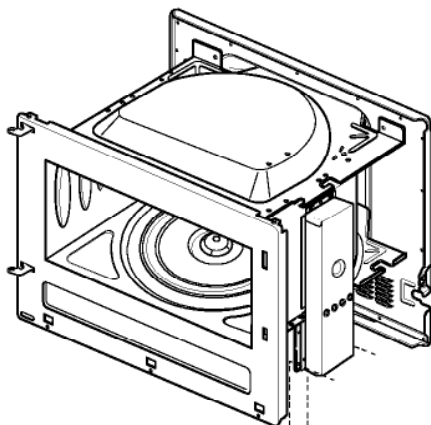

Magnetron

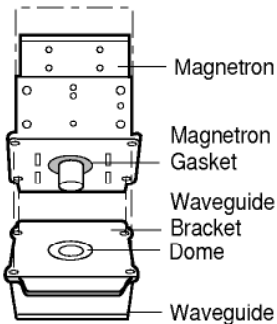

Magnetron

Magnetron

Gasket

Waveguide

Bracket

Dome

Waveguide

Figure 14

I. REMOVING THE TURNTABLE MOTOR

- (1) Remove the turntable and turntable roller rest.
- (2) Lay the unit down on its back.
- (3) Remove the turntable motor cover.
The turntable base cover is easily removed by pinching the four parts with a wire cutting.
- (4) Disconnect the leadwire from the turntable motor terminals.
- (5) Remove the screw securing the turntable motor to the oven cavity ASSEMBLY.
- (6) After repairing the motor, rotate the removed turntable motor cover.
- (7) Fit the turntable motor cover's projecting part to the base plate slit.

NOTE:

1. Remove the lead wires from the turntable motor VERY CAREFULLY.
2. Be sure to grasp the connector, not the wires, when removing.

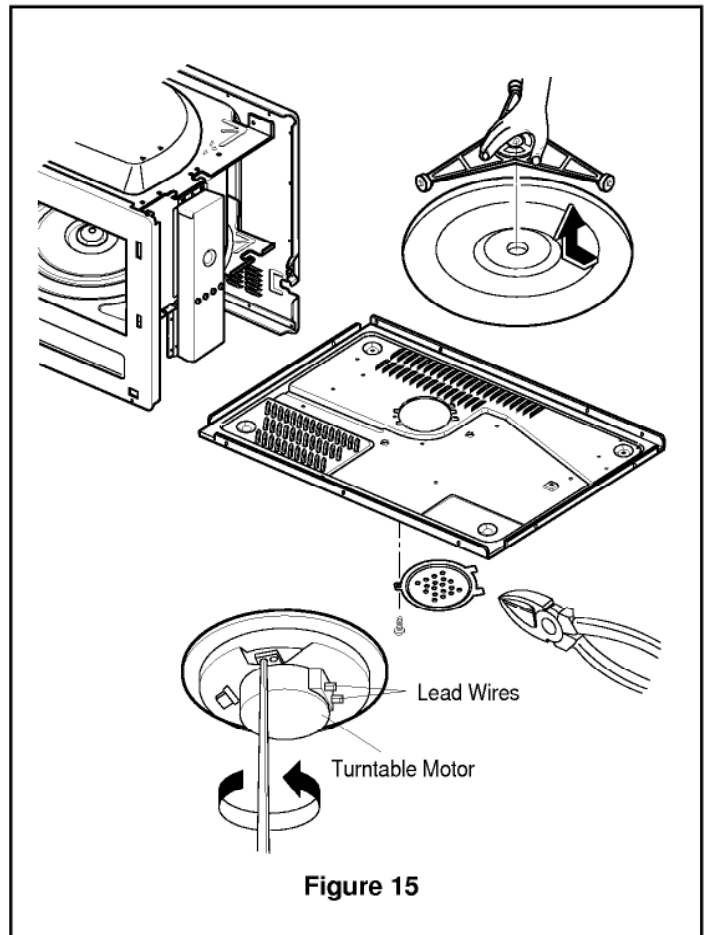

Figure 15

10. INTERLOCK CONTINUITY TEST

WARNING : FOR CONTINUED PROTECTION AGAINST EXCESSIVE RADIATION EMISSION, REPLACE ONLY WITH IDENTICAL REPLACEMENT PARTS.

TYPE NO. SZM-V 16-FA-63 OR VP-533A-OF OR V-5230Q FOR PRIMARY SWITCH

TYPE NO. SZM-V 16-FA-62 OR VP-532A-OF OR V-5220Q FOR MONITOR SWITCH

TYPE NO. SZM-V 16-FA-63 OR VP-533A-OF OR V-5230Q FOR SECONDARY SWITCH

A. PRIMARY INTERLOCK SWITCH TEST

When the door release button is depressed slowly with the door closed, an audible **click** should be heard at the same time or successively at intervals. When the button is released slowly, the latches should activate the switches with an audible **click**.

If the latches do not activate the switches when the door is closed, the switches should be adjusted in accordance with the adjustment procedure. Disconnect the wire lead from the primary switch. Connect the ohmmeter leads to the common (COM) and normally open (NO) terminal of the switch. The meter should indicate an open circuit in the door open condition. When the door is closed, the meter should indicate a closed circuit.

When the primary switch operation is abnormal, make the necessary adjustment or replace the switch only with the same type of switch.







B. SECONDARY INTERLOCK SWITCH TEST

Disconnect the wire lead from the secondary switch. Connect the ohmmeter leads to the common (COM) and normally open (NO) terminals of the switch. The meter should indicate a open circuit in the door open condition. When the door is closed, meter should indicate an closed circuit. When the secondary switch operation is abnormal, make the necessary adjustment or replace the switch only with the same type of switch.

C. MONITOR SWITCH TEST

Disconnect the wire lead from the monitor switch. Connect the ohmmeter leads to the common (COM) and normally closed (NC) terminals of the switch. The meter should indicate closed circuit in the door open condition. When the door is closed, meter should indicate an open circuit. When the monitor switch operation is abnormal, replace with the same type of switch.

NOTE: After repairing the door or the interlock system, it is necessary to do this continuity test before operating the oven.

COMPONENTS	TEST PROCEDURE	RESULTS	
		Door open	Door closed
SWITCHES (Lead wires removed)	Check for continuity of the switch with an Ohm-meter		
	Primary Switch		
	Monitor Switch		
	Secondary Switch		
NOTE : After checking for the continuity of switches, make sure that they are connected correctly.			

11. TEST AND CHECKOUT PROCEDURES, AND TROUBLESHOOTING

CAUTIONS

1. DISCONNECT THE POWER SUPPLY CORD FROM THE OUTLET WHENEVER REMOVING THE OUTER CASE FROM THE UNIT. PROCEED WITH THE TEST ONLY AFTER DISCHARGING THE HIGH VOLTAGE CAPACITOR AND REMOVING THE LEAD WIRES FROM THE INVERTER MODULE.
2. ALL OPERATIONAL CHECKS WITH MICROWAVE ENERGY MUST BE DONE WITH A LOAD (1 LITER OF WATER IN CONTAINER) IN THE OVEN.

A. TEST PROCEDURES

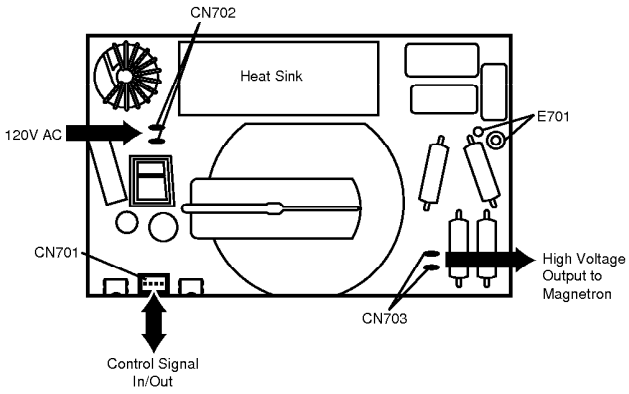
COMPONENTS	TEST PROCEDURE	RESULTS
<p>INVERTER (Lead wires removed)</p>	 <p>Note: Do not try to repair the inverter board, nor try to make any adjustments to the board.</p> <p>Check wiring to the inverter:</p> <ol style="list-style-type: none"> 1. Unplug the oven's main power supply. 2. Visually inspect 4 connectors on the inverter board: CN701, CN702, CN703, E701 to see whether there are any signs of failure due to loose wires, bad crimping, sign of overheating, etc. 	
<p>MAGNETRON (Lead wires removed)</p>	<ol style="list-style-type: none"> 1. Measure the resistance. (Ohm-meter scale: Rx1) • Filament terminal 2. Measure the resistance. (Ohm-meter scale: Rx1000) • Filament to chassis 	<p>Normal: Less than 1 ohm</p> <p>Normal: Infinite</p>

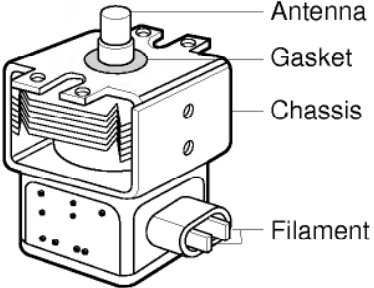
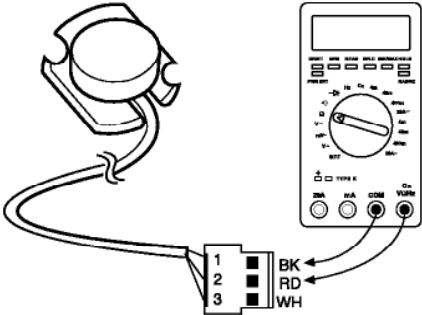
COMPONENTS	TEST PROCEDURE	RESULTS
	 <p data-bbox="517 636 1426 698">NOTE: When testing the magnetron, be sure to install the magnetron gasket in the correct position and be sure that the gasket is in good condition.</p>	
SENSOR	<ol data-bbox="529 743 1015 869" style="list-style-type: none"> 1. Disconnect sensor connector from micom computer board. 2. Measure resistance terminal to terminal (Select the ohm scale on the meter)  <p data-bbox="529 1303 1034 1482">NOTE: MAKE SURE THE LEAD WIRES ARE IN THE CORRECT POSITION. WHEN REMOVING THE LEAD WIRES FROM THE PARTS, BE SURE TO GRASP THE CONNECTOR, NOT THE WIRES.</p>	<p data-bbox="1114 743 1369 842">Normal: Approximately BK-RD: 5.2 Kohms RD-WH: 2.1 Kohms BK-WH: 2.1 Kohms</p> <p data-bbox="1114 869 1305 927">Abnormal: Infinite or several</p> <p data-bbox="1114 958 1407 990">*Sensor cooking condition</p> <ol data-bbox="1114 994 1474 1361" style="list-style-type: none"> 1. Oven should be plugged in at least 5 minutes before sensor cooking. 2. Room temperature should not exceed 95°F. 3. Be sure the exterior of the cooking container and the interior of the oven are dry. 4. The oven will not generate microwave energy for the first 28 seconds of the sensor cooking cycle.

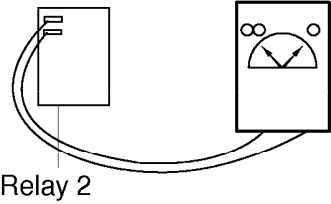
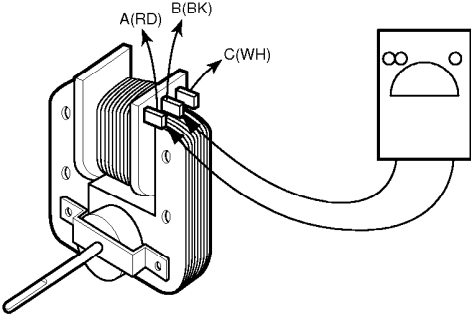
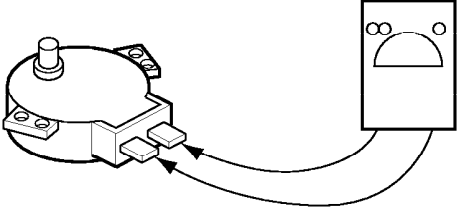
COMPONENTS	TEST PROCEDURE	RESULTS
RELAY	<p>Check for continuity of relay with an ohm-meter. (Remove lead wires from relay and operate the unit.)</p> 	<p>Normal: Approx. ON: 0 ohm OFF: ∞ ohms Abnormal: Infinite or several ohms.</p>
FAN MOTOR (Wire leads removed)	<p>Measure the resistance. (Ohm-meter scale: R x 100)</p> 	<p>Normal: Approx. 50 ~ 150 ohms Abnormal: Infinite or several ohms.</p>
TURNTABLE MOTOR (Wire leads removed)	<p>Measure the resistance. (Ohm-meter scale: R x 1000)</p> 	<p>Normal: Approx. 2 ~ 4K ohms Abnormal: Infinite or several ohms.</p>
<p>NOTE : • A MICROWAVE LEAKAGE TEST MUST ALWAYS BE PERFORMED WHEN THE UNIT IS SERVICED FOR ANY REASON. • MAKE SURE THE WIRE LEADS ARE IN THE CORRECT POSITION. • WHEN REMOVING THE WIRE LEADS FROM THE PARTS, BE SURE TO GRASP THE CONNECTOR, NOT THE WIRES.</p>		

B. CHECKOUT PROCEDURES

(1) CHECKOUT PROCEDURES FOR FUSE BLOWING

CAUTION: REPLACE BLOWN FUSE WITH 20 AMPERE FUSE.

PROBLEMS	CAUSES
Fuse blows immediately after the door is closed.	Improper operation of the primary interlock, secondary interlock switches and/or the interlock monitor switch.
Fuse blows immediately after the door is opened.	
Fuse blows when the door is closed and START key is touched.	Malfunction of the Inverter, the magnetron, the fan motor or the circuit board.

NOTES:

- If the fuse is blown by an improper switch operation, replace the defective switches and the fuse at the same time. After replacing the defective switches with new ones, make sure that they are correctly connected.
- Check for microwave energy leakage according to "1. ADJUSTMENT PROCEDURES" on page 3, when the primary interlock, secondary interlock switches and/or the interlock monitor switches are adjusted or replaced.

(2) CHECKOUT PROCEDURES FOR RELAY

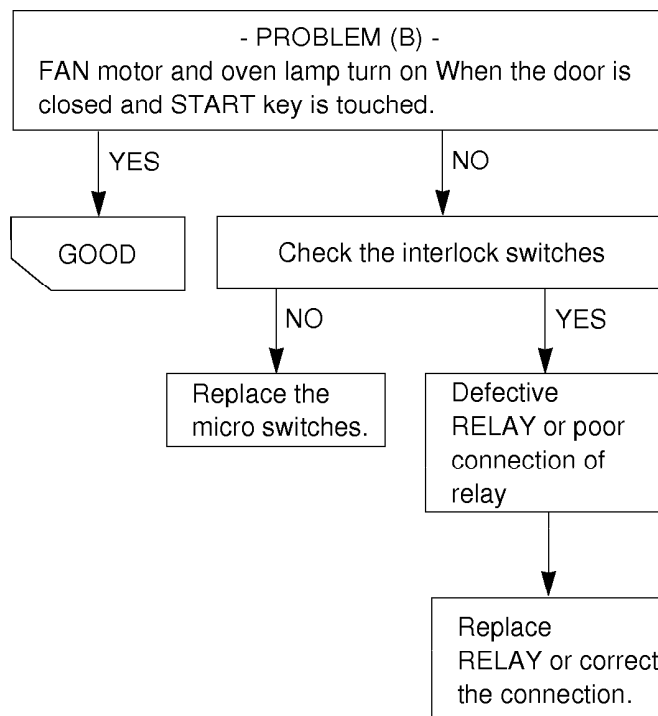
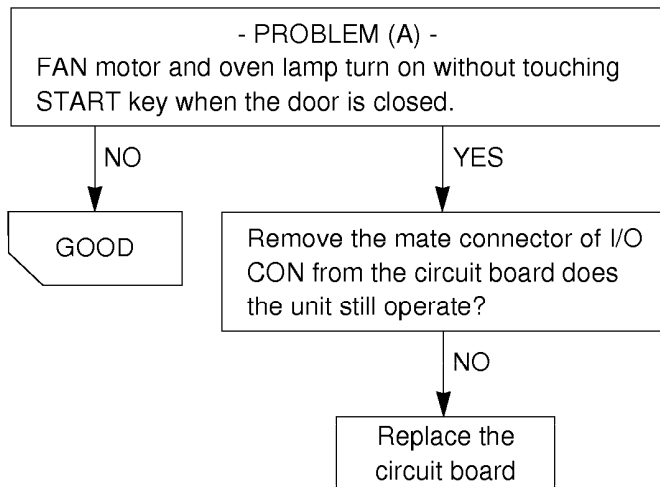

(3) CHECKOUT PROCEDURES FOR CIRCUIT BOARD

The following symptoms indicate a defective circuit board.

- (1) Check the input current. If the input current is more than 20A, check the magnetron and wiring. If the input current is less than 0.5 A, there is no input to the inverter.
- (2) The start function fails to operate but the interlock switches, the door sensing and the relay check good.
- (3) The unit with a normal relay continuously operates.
- (4) The buzzer does not sound or continues to sound.
- (5) Some segments of one or more digits do not light up, or they continue to light up, or segments light when they should not.
- (6) Wrong figures appear.
- (7) The figures of all digits flicker.
- (8) Some of the indicators do no light up.
- (9) The clock does not keep time properly.

NOTE: A MICROWAVE ENERGY LEAKAGE TEST MUST ALWAYS BE PERFORMED WHEN THE UNIT IS SERVICED FOR ANY REASON.

C. TROUBLE SHOOTING

WHEN YOU GET A COMPLAINT FROM YOUR CUSTOMER, EVALUATE THE COMPLAINT CAREFULLY. IF THE FOLLOWING SYMPTOMS APPLY, PLEASE INSTRUCT THE CUSTOMER IN THE PROPER USE OF THE MICROWAVE OVEN. THIS CAN ELIMINATE AN UNNECESSARY SERVICE CALL.

CAUTIONS

1. Check grounding before checking for trouble.
2. Be careful of the Inverter.
3. When checking the continuity of the switches or of the inverter, disconnect one lead wire from these parts and then check continuity with the AC plug removed. To do otherwise may result in a false reading or damage to your meter.
4. Do not touch any part of the circuit on the PCB since static electric discharge may damage this control panel.
Always touch yourself to ground while working on this panel to discharge any static charge built up in your body. (Micom model only)

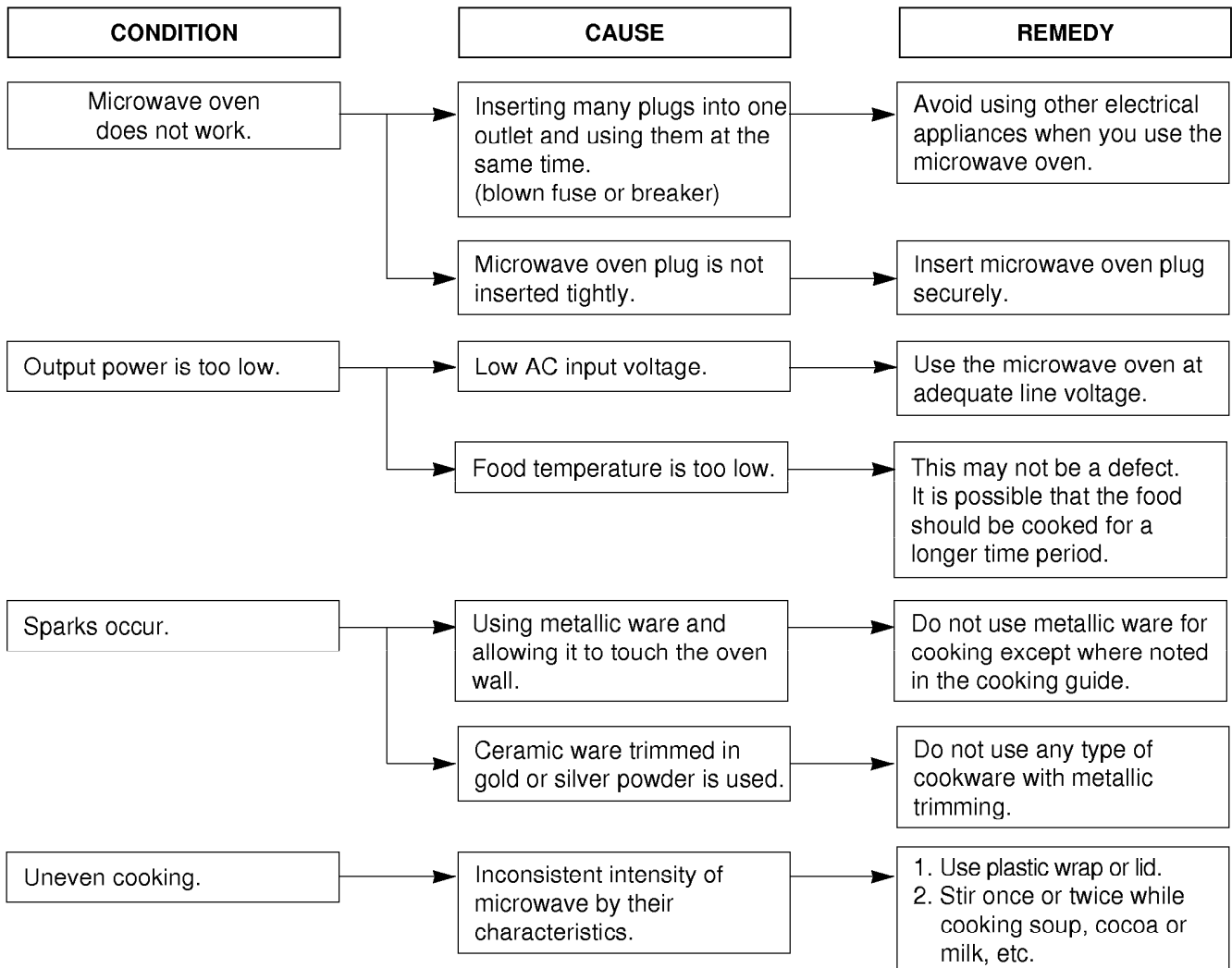

(TROUBLE 1) The following visual conditions indicate a probable defective control circuit.

1. Incomplete segments.
 - Segment missing.
 - Partial segment missing.
 - Digit flickering (NOTE: Slight flickering is normal.)
2. Colon does not turn on or blink.
3. A distinct change in the brightness of one or more numbers in display.
4. One or more digits in the display are not lighting.
5. Display indicates a number different from one touched, for example, key in **5** and **3** appears in the display.
6. Specific numbers (for example 7 or 9) will not display when key pad is touched.
7. Display does not count down with time blinking or up with clock operation.
8. Display obviously jumps in time while counting down.
9. Display counts down too fast while cooking.
10. Each indicator light does not turn on after setting cooking cycle.
11. Display time of day does not reappear when cooking is finished.

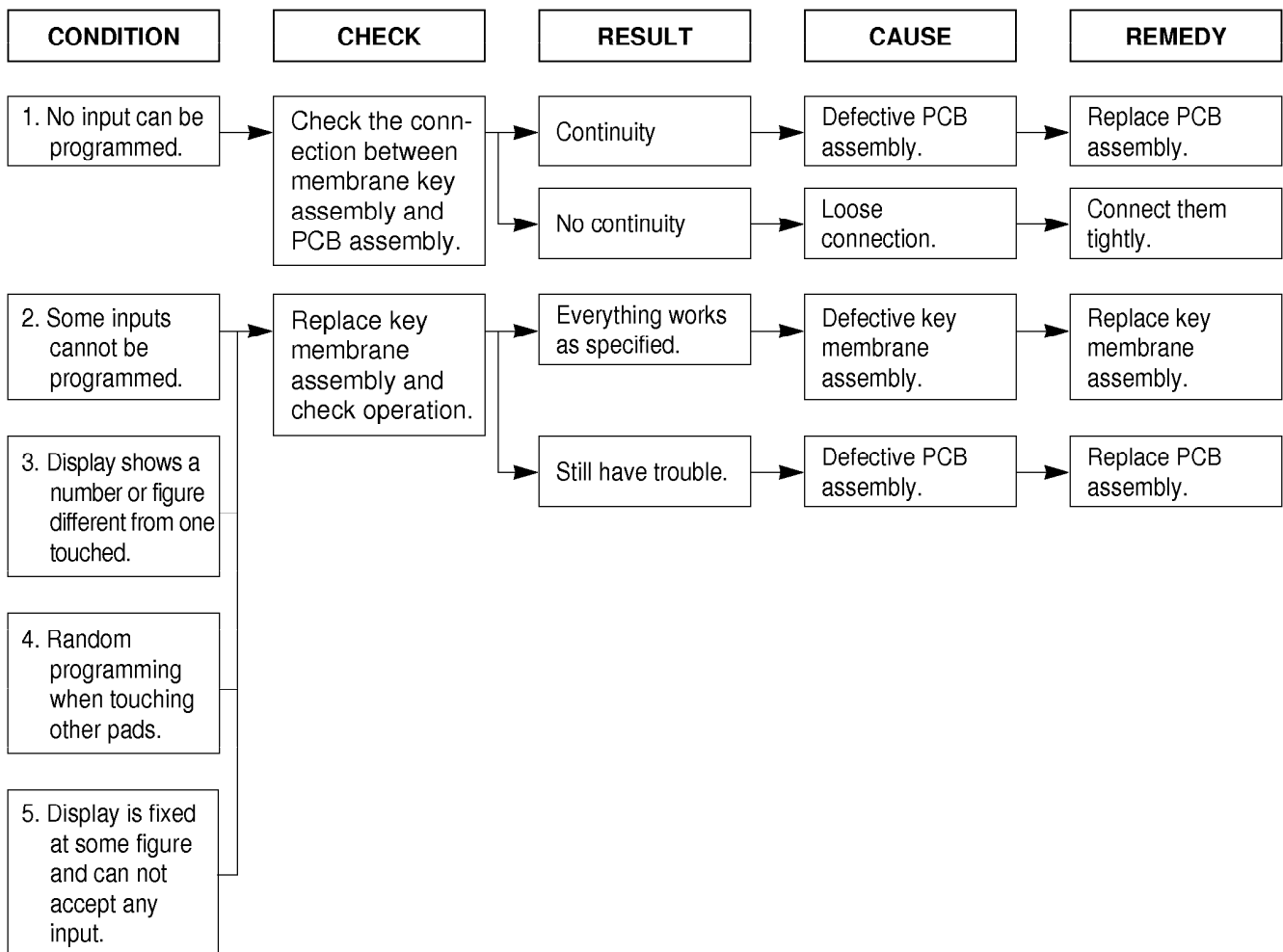

(TROUBLE 2) Oven does not operate at all, Display window does not display any figures, and no input is accepted.

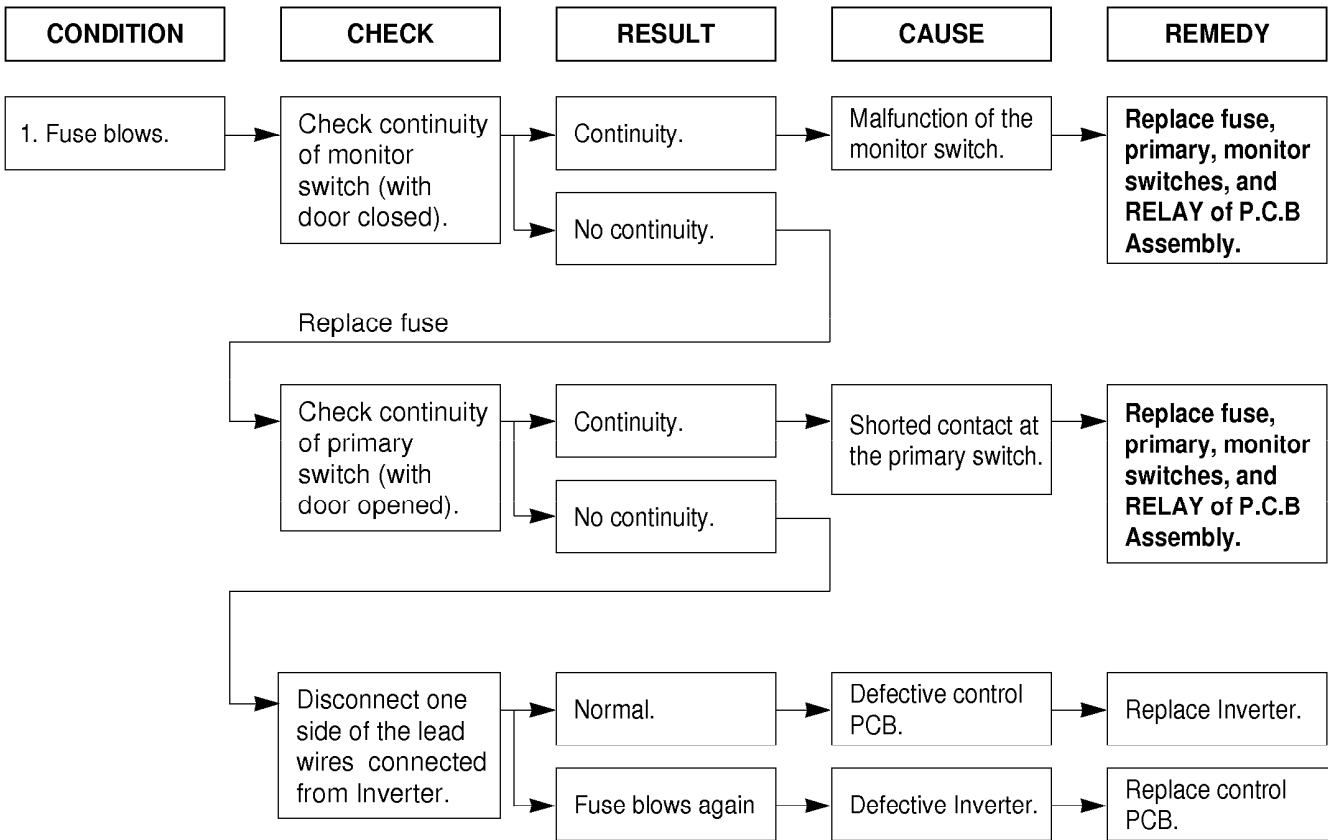

NOTE : All these switches must be replaced at the same time. Refer to page 18, 19

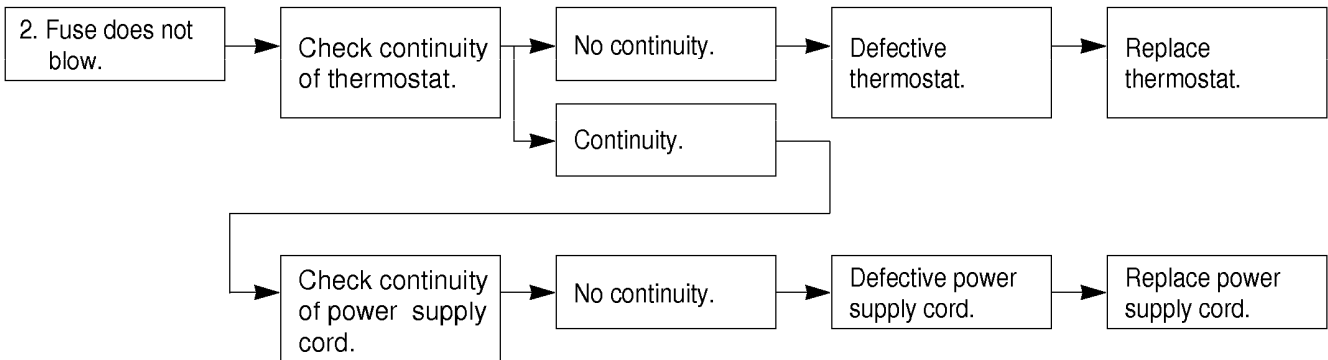

(TROUBLE 3) Display shows all figures set, but oven does not start cooking while desired program times are set and START pad is touched.

CONDITION	CHECK	RESULT	CAUSE	REMEDY
1. Setting time does not count down when touching START pad.	Check continuity of secondary switch (with door closed).	No continuity.	Defective secondary switch.	Replace secondary switch.
		Continuity.		
	Check the connection between CN1 connector and PCB assembly.	Continuity	Defective Power PCB assembly.	Replace Power PCB assembly.
		No continuity	Loose connection.	Connect them tightly.
2. Fan motor or oven lamp do not turn on.	Check fan motor.	Abnormal	Defective fan motor.	Replace fan motor.
	Check oven lamp.	Abnormal	Defective oven lamp.	Replace oven lamp.
		Normal		

(TROUBLE 4) Oven seems to be operating but little heat is produced in oven load.

CONDITION	CHECK	RESULT	CAUSE	REMEDY
Output is low	Check the power source voltage.	Lower than 90% of rating voltage.	Decrease in power source voltage with load.	Suggest customer contact local electric power utility co. or qualified electrician.
		Normal		
			Defective Magnetron.	Replace Magnetron.

NOTE : Simple test of power output-conducted by heating one liter water for one min. if available.
Minimum 8.5°C temperature rise is normal condition.

**(TROUBLE 5) No microwave oscillation even though oven lamp and fan motor run.
(Display operates properly)**

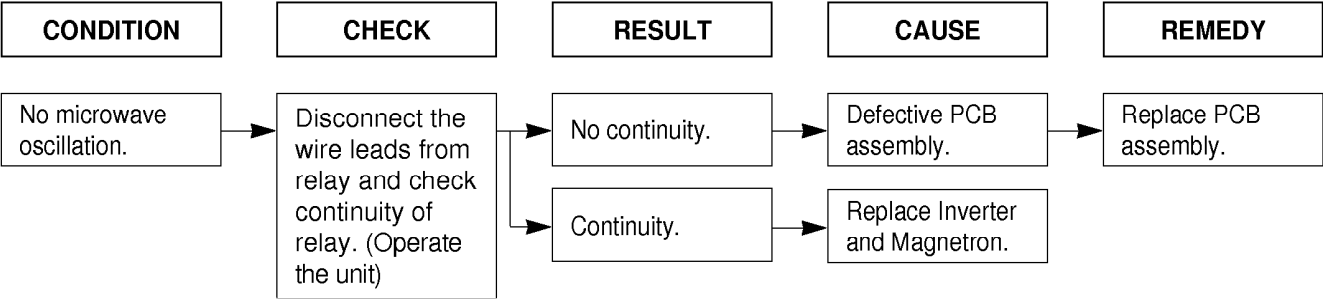

- NOTE :**
- Make sure the wire leads correct position.
 - When Removing the lead wires from the parts, be sure to grasp the connector, not the wires.
 - When removing the magnetron, be sure to install the magnetron gasket in the correct position and in good condition.

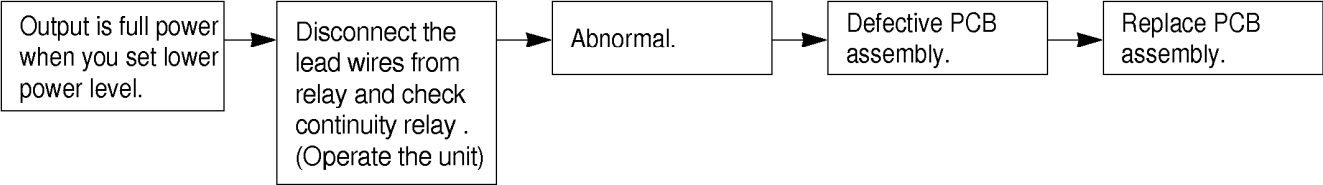

KENMORE MICROWAVE OVEN
MODEL NO. 721.62362 721.62364
721.62365 721.62369

INTRODUCTION

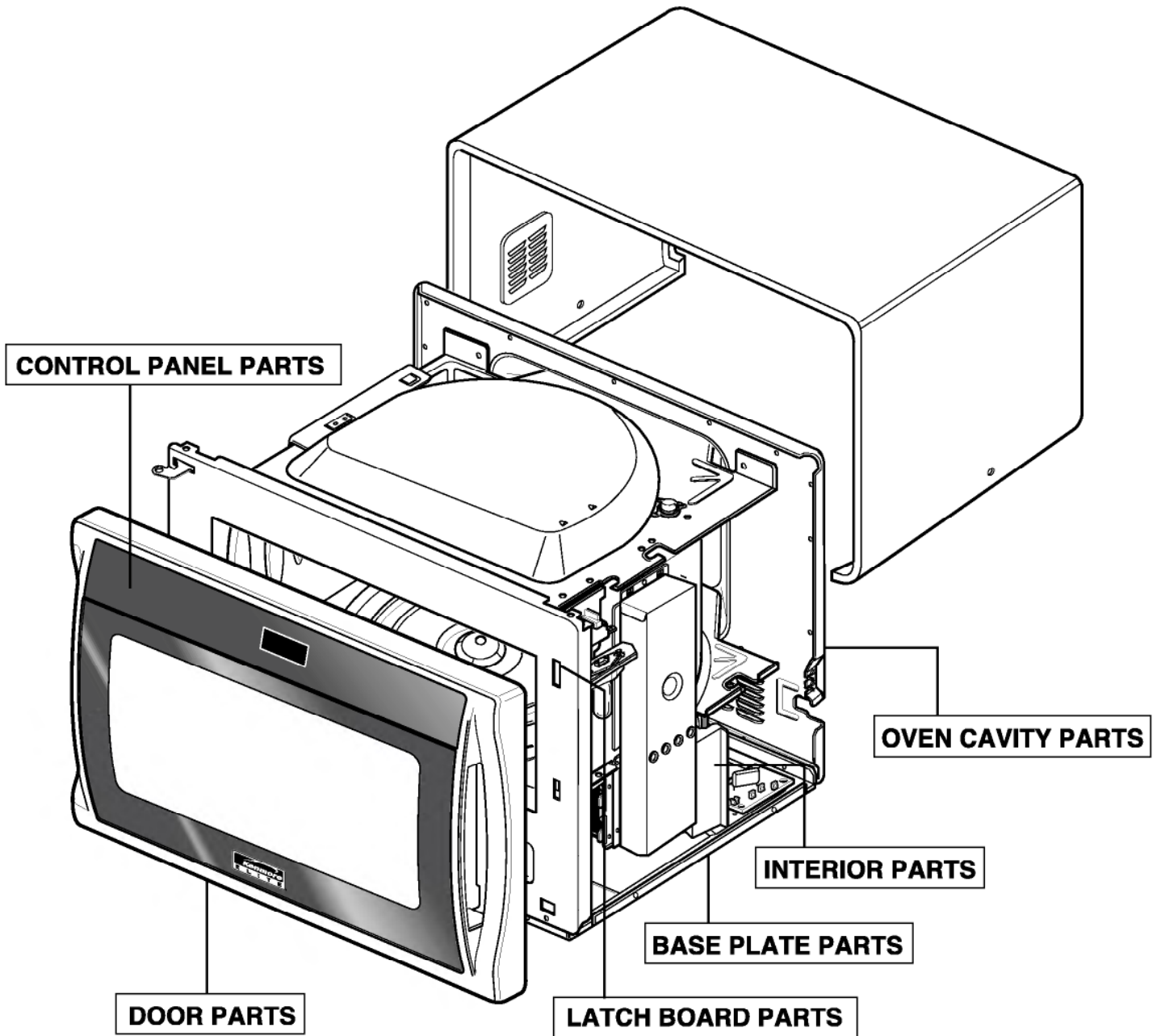

KENMORE MICROWAVE OVEN
MODEL NO. 721.62362 721.62364
721.62365 721.62369

DOOR PARTS

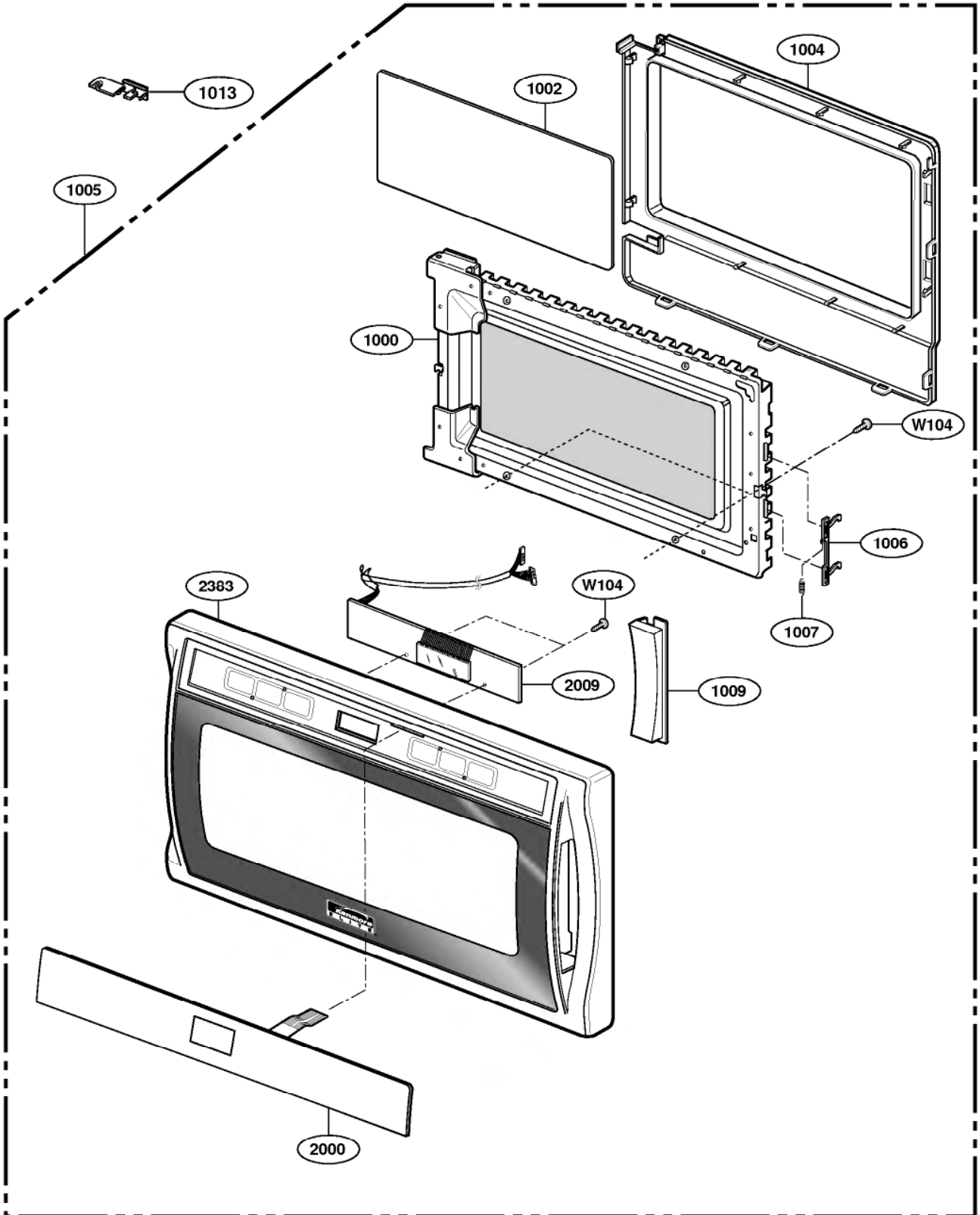

KENMORE MICROWAVE OVEN
MODEL NO. 721.62362 721.62364
721.62365 721.62369

CONTROLLER PARTS

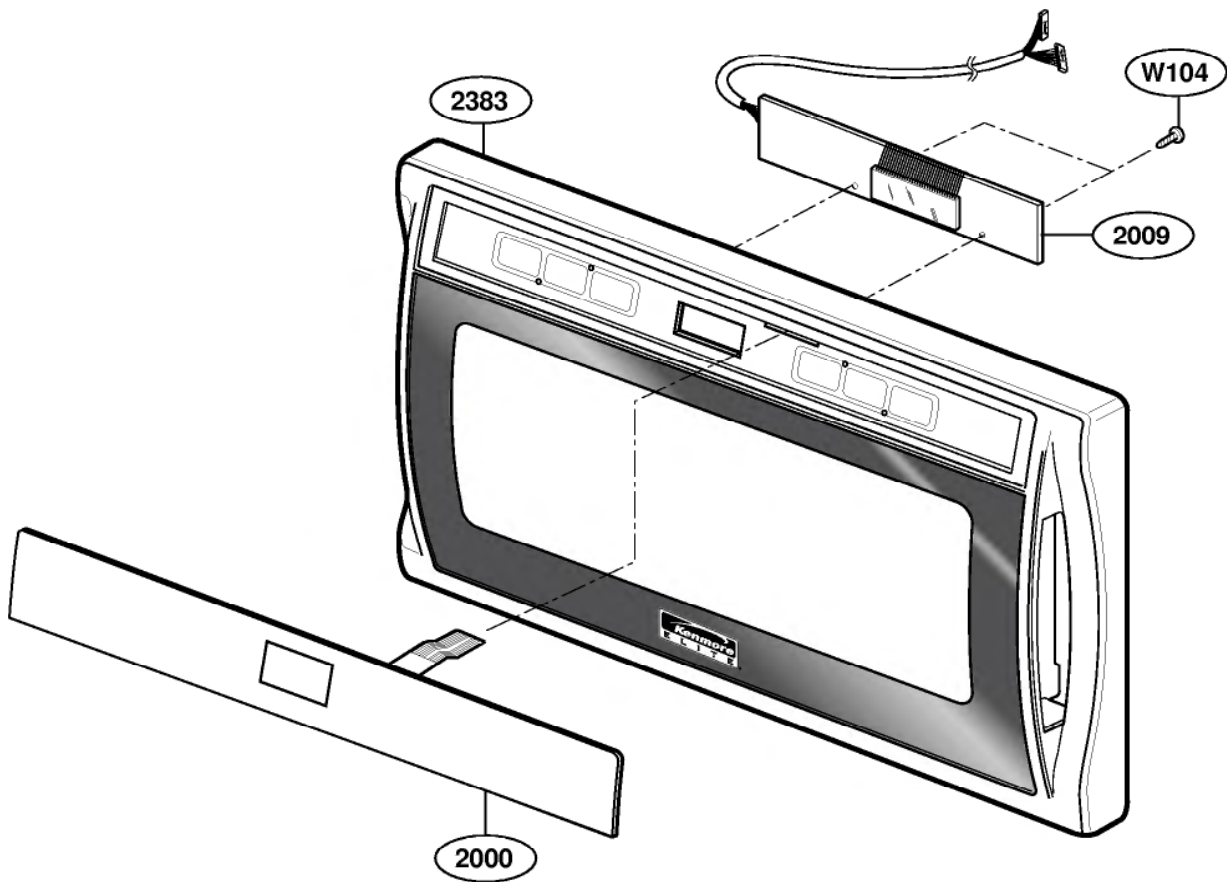

KENMORE MICROWAVE OVEN
 MODEL NO. 721.62362 721.62364
 721.62365 721.62369

OVEN CAVITY PARTS

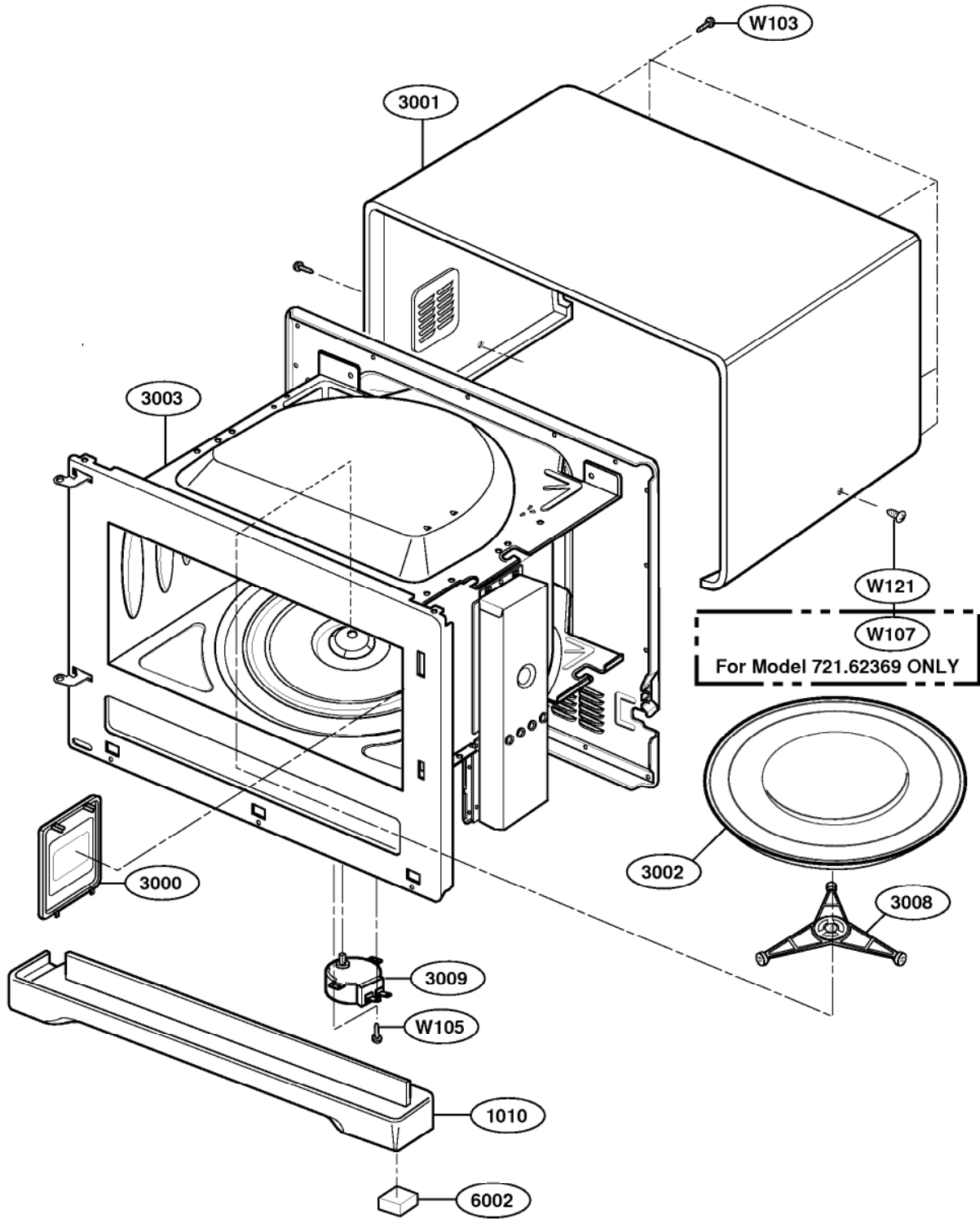

KENMORE MICROWAVE OVEN
MODEL NO. 721.62362 721.62364
721.62365 721.62369

LATCH BOARD PARTS

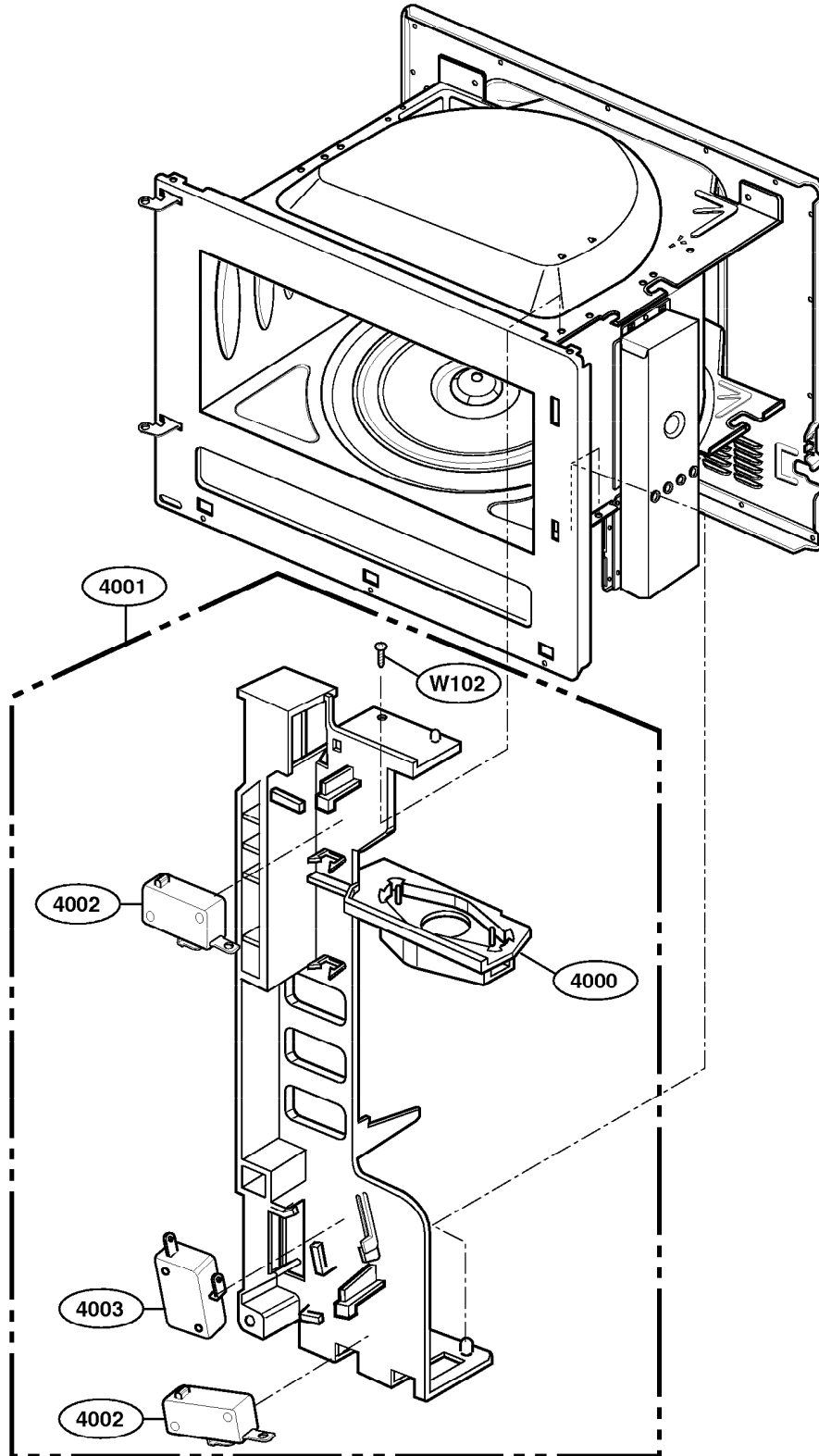

KENMORE MICROWAVE OVEN
MODEL NO. 721.62362 721.62364
721.62365 721.62369

OVEN INTERIOR PARTS

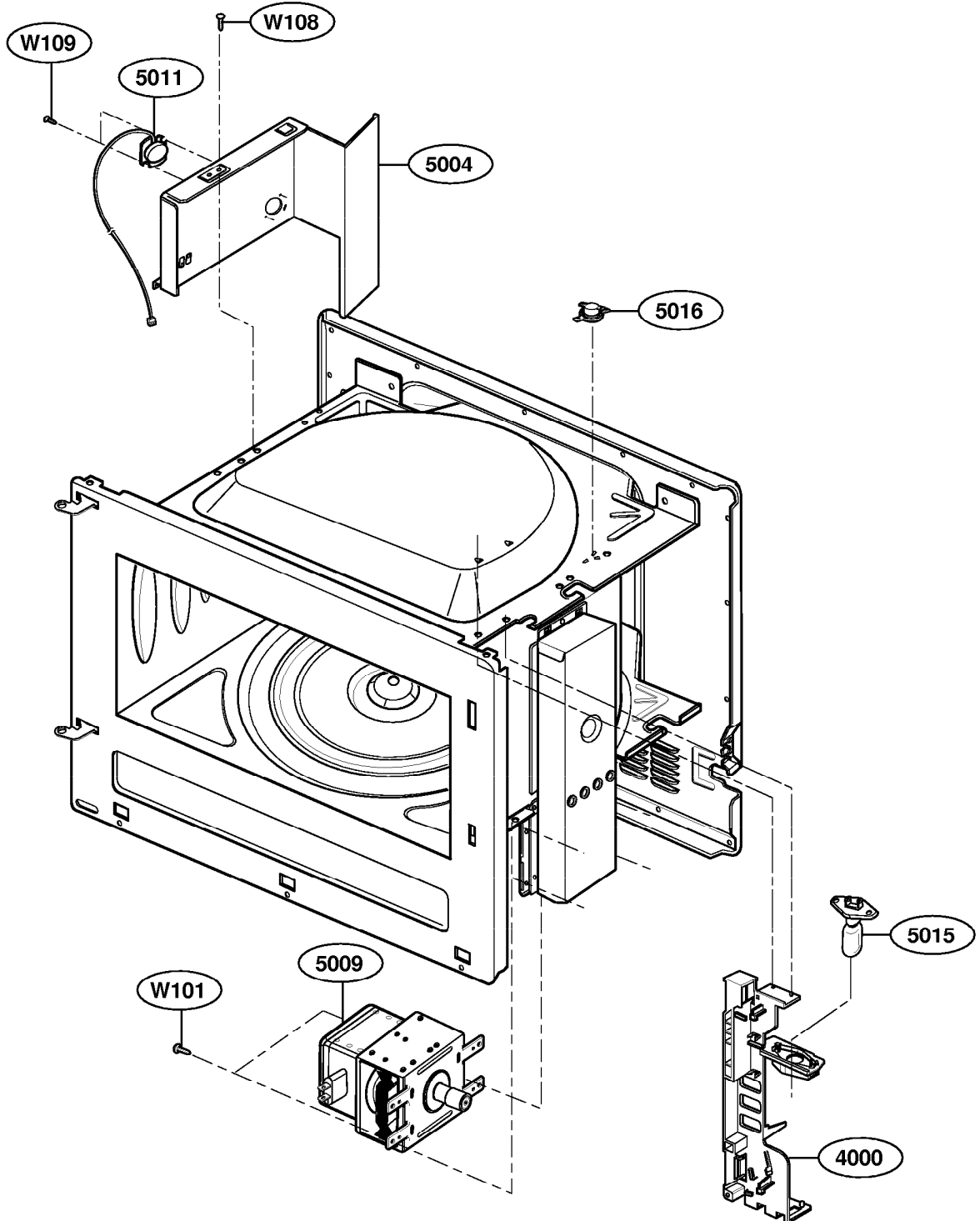

KENMORE MICROWAVE OVEN
MODEL NO. 721.62362 721.62364
721.62365 721.62369

BASE PLATE PARTS

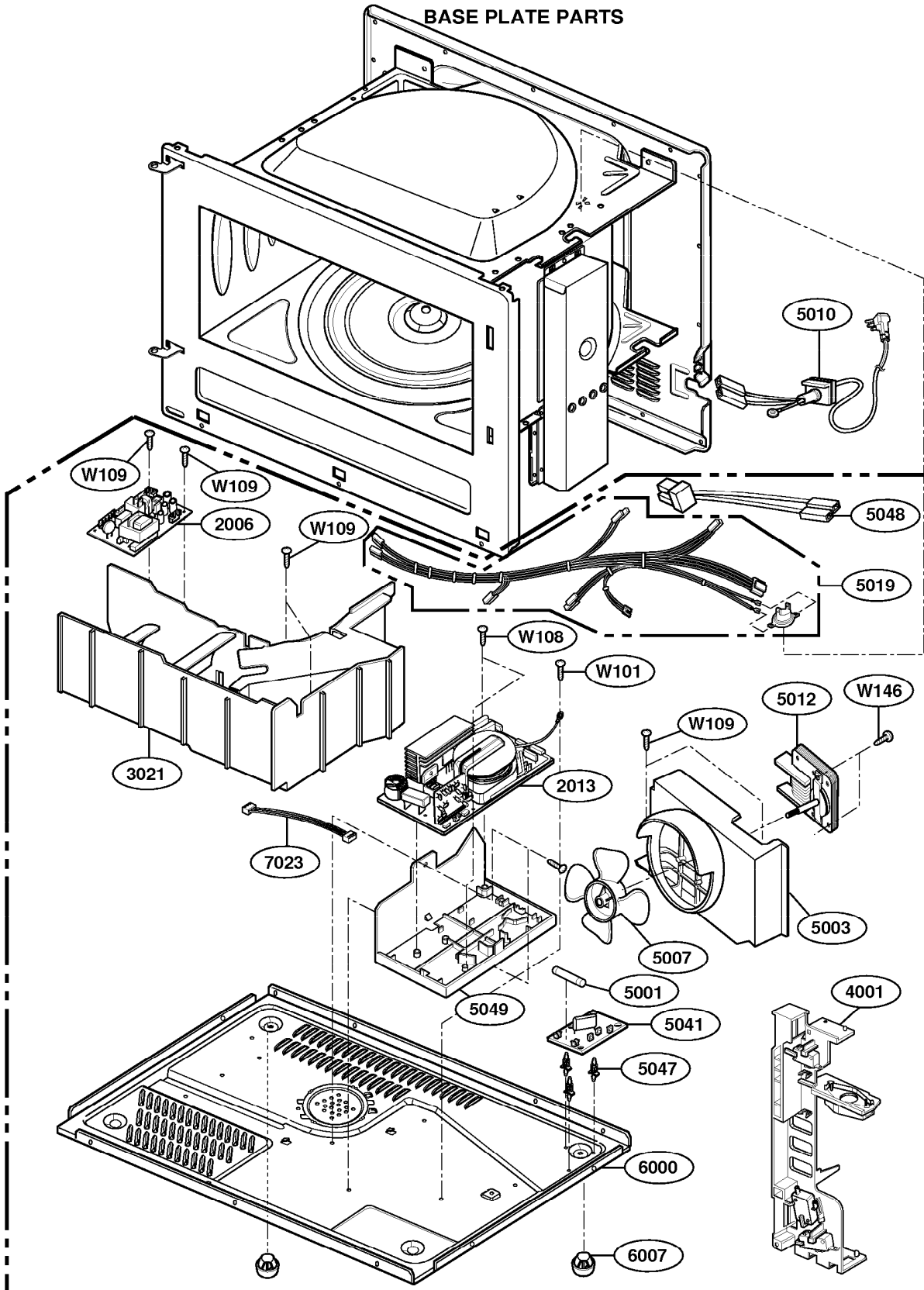

SCHEMATIC DIAGRAM OF P.C.B

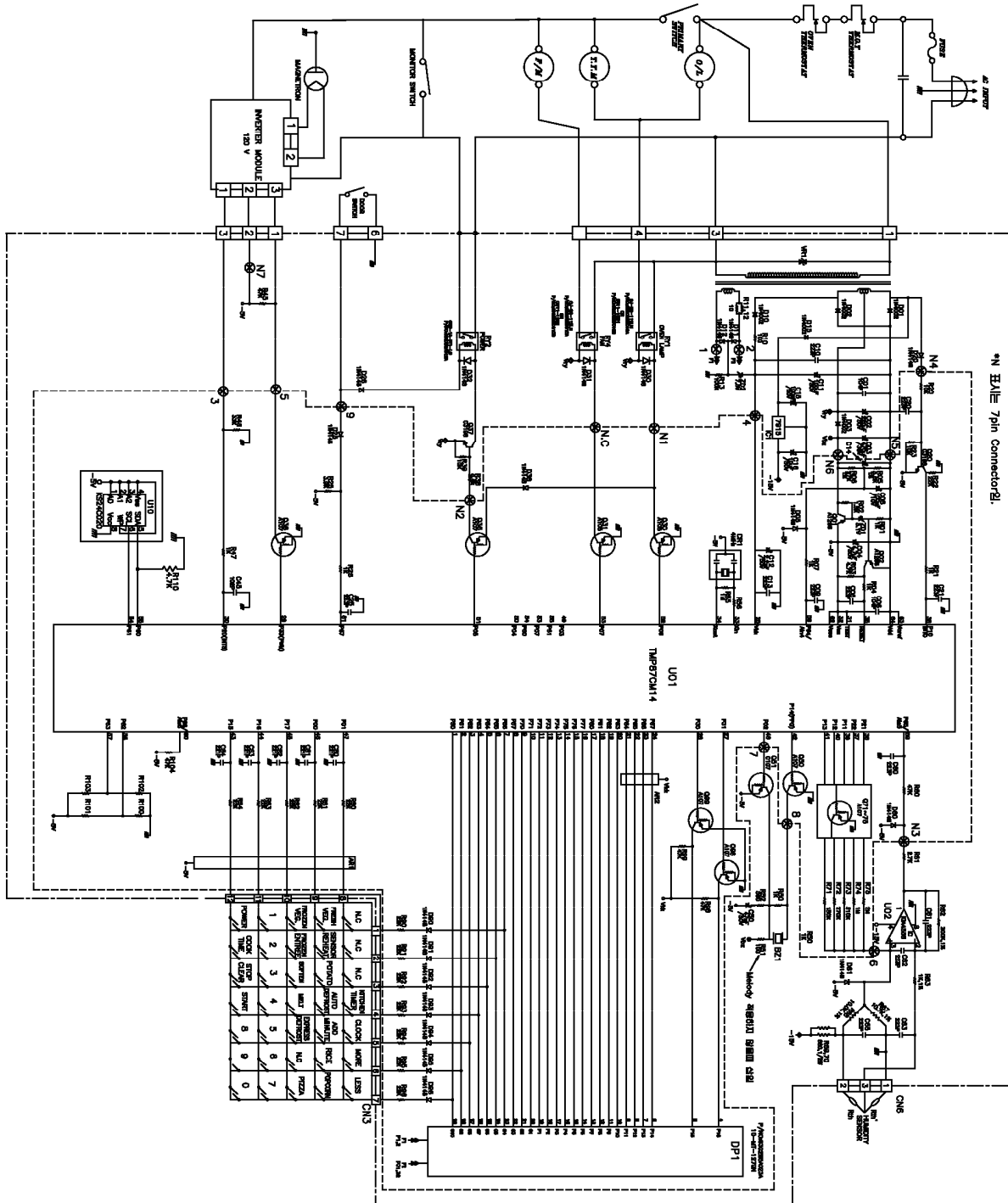

PRINTED CIRCUIT BOARD

KEY PCB

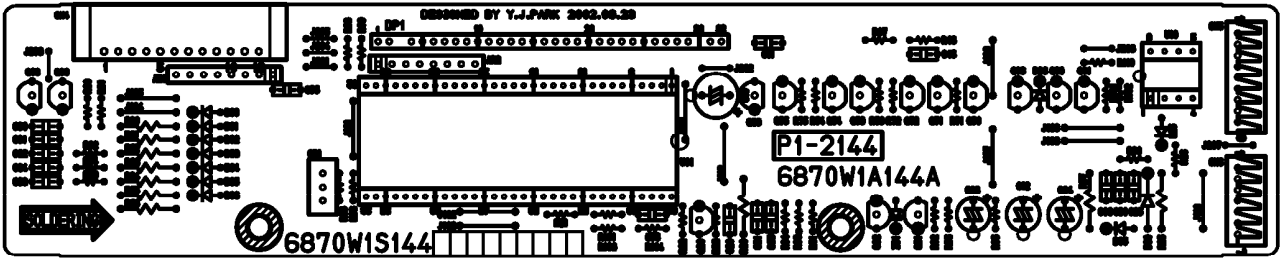

MAIN PCB

