

This Owner's Manual is provided and hosted by [Appliance Factory Parts](#).



# ULTRAVATION 90-037 Owner's Manual

[Shop genuine replacement parts for ULTRAVATION  
90-037](#)



[Find Your ULTRAVATION Air Cleaner Parts - Select From 378 Models](#)

----- Manual continues below -----

# Ultravation®

## Complete Whole House Air Cleaning System Straight Through Media Air Cleaner OWNERS GUIDE



**Models: 90-005, 90-006, 90-007, 90-015, 90-016**  
**Models: 90-036, 90-037, 90-038, 90-039 (14" Wide Cabinet)**

### Table of Contents:

Page 2 - Shipping and Packing List, Introduction, Applications, Installation requirements, Maintenance

Page 3 - Typical mounting positions

Page 4- Turning Vanes, Transitions, Humidifiers, Air Conditioning

Page 5- **Photronic Upgradeable Options**, Filter Specifications

Page 6- Warranty, Replacement Filters

**LEAVE FOR HOMEOWNER**

### Shipping and Packaging List:

- Filter Housing including Access Doors
- MERV-11 Media Air Filter

### Introduction and Application:

This Ultravation Media Air Cleaner is a high efficiency air filtration unit designed to remove dirt, dust, pollen, and other microscopic particles from the air that circulates through it. By adding this device to your HVAC system, you are helping to create a cleaner indoor living environment for your whole household.

The filter works by trapping particles in the pleats of the media filter. With an extra large surface area, the filter allows for maximum dirt holding capacity and a long, useful filter life with minimum air flow restriction.

This media air cleaner is to be installed in a forced air heating, cooling and ventilation system. It should be installed so that all the system air is circulated through the filter. The air cleaner will only filter the air that is circulated through it. For maximum filtration effect, set your blower to operate continuously.

### Installation Requirements:

The desired location for installation of the Ultravation Media Air Cleaner is in the return air next to the blower compartment. In this location, the blower motor and internal components will be kept clean.

By installing the air cleaner in this location (upstream from the cooling coils) you also will assure that the cooling coils of the air conditioning system will be kept clean. This increases coil life, improves system efficiency, and reduces maintenance costs.

Once the Ultravation Media Air Cleaner is installed, it is very important to maintain the unit by changing the filter periodically so as not obstruct airflow, damage components or increase energy costs.

The Ultravation Media Air Cleaner has been designed for use in conjunction with many styles of HVAC systems.

Do not install this unit in the supply duct.

Be sure to plan adequate space to allow filter replacement.

Before installation is complete, seal all joints and seams airtight with duct tape or caulking.

### Maintenance:

The filter media in your air cleaner must be changed periodically. The frequency of filter replacement is best determined by visual examination. However, an annual replacement of the filter is strongly recommended.

**Replacement filters** can be obtained through your installing contractor or local dealer.

Steps for replacing filter:

1. Open the access door by pressing down on handle then pull top of door forward slightly and lift.
2. Pull out used filter and discard.
3. Slide new filter into cabinet with "airflow label pointing in the direction of the airflow.
4. Replace access door.

# Typical mounting positions:

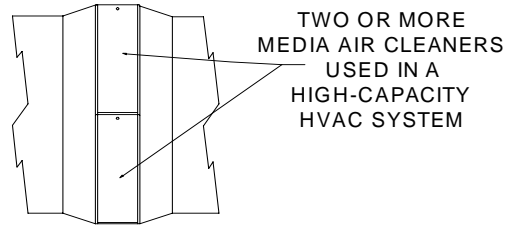
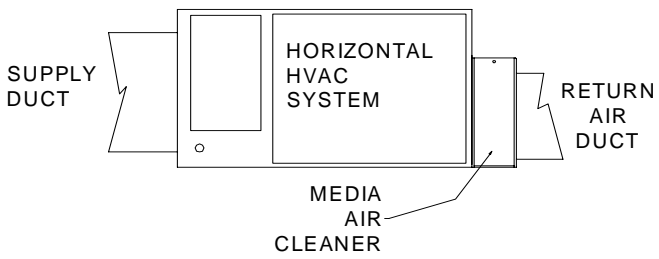
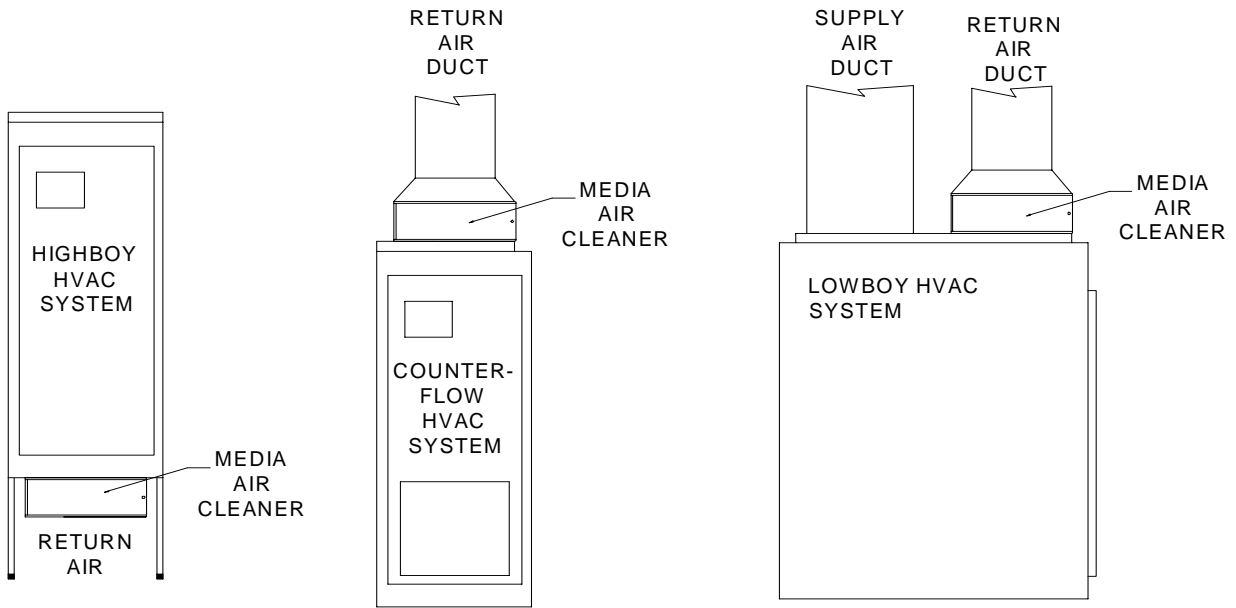

### Turning Vanes:

If the air cleaner is installed adjacent to a 90-degree duct elbow, add turning vanes inside the duct to improve the air distribution across the face of the air cleaner. (See diagram below)

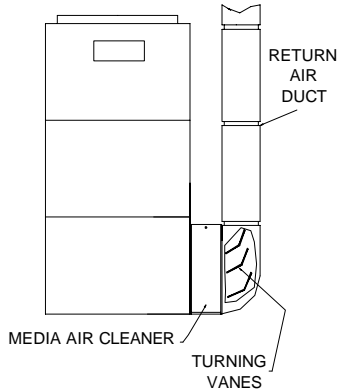

### Application with a Humidifier:

The Media Air Cleaner is compatible with humidifiers. Avoid applications where water mist will reach the media. When an evaporative type humidifier is used, it may be installed between the furnace warm air duct and the return air duct without affecting the air cleaner. Atomizing and spray type humidifiers should be installed at least 6 feet between the air cleaner and humidifier.

### Air Conditioning:

The air cleaner should be installed upstream of the cooling coil. This will keep the coil clean and reduce air conditioning coil maintenance. Improved cooling efficiency is the result, which directly affects energy costs. A clean coil will reduce utility costs. Failure to replace media can cause damage to the cooling system.

### Transitions:

If the air duct does not fit the air cleaner cabinet opening, gradual transitions are recommended to reduce air turbulence through the air cleaner and maximize efficiency. Not more than 20 degrees (about 4" per running foot) of expansion should be used on each side of the transition fitting. (See diagram above)

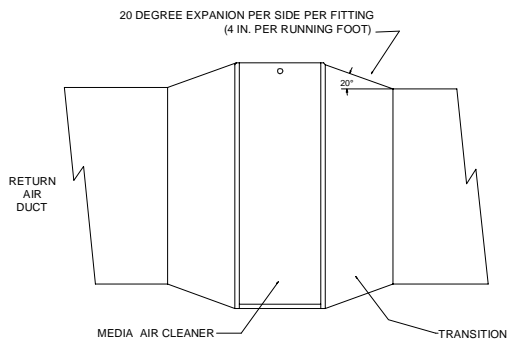

**Photronic Upgradeable Options**

Most of Ultravations media air cleaners are designed for the future upgrades. Excluding a few of Ultravations media air cleaners all of the units are upgradeable to high efficiency Photronic air disinfection. The units come equipped with removable knock outs and designed to fit the Ultra-Ion Re-fresh PCO module. Another option to the upgrade is remote UVC lamps which can be located within 12 ft. of the electrical Photronic housing. With these upgrades your unit becomes a high efficiency multi stage air disinfection system. The Photronic works in 3 stages to remove almost everything in your air stream, starting with large particles (dust and other airborne debris), then removing odors through the Ultra-Ion Re-fresh PCO module, and finally removing microorganisms (germs, mildew, mold) using Ultravations patented T3 UVC lamps.

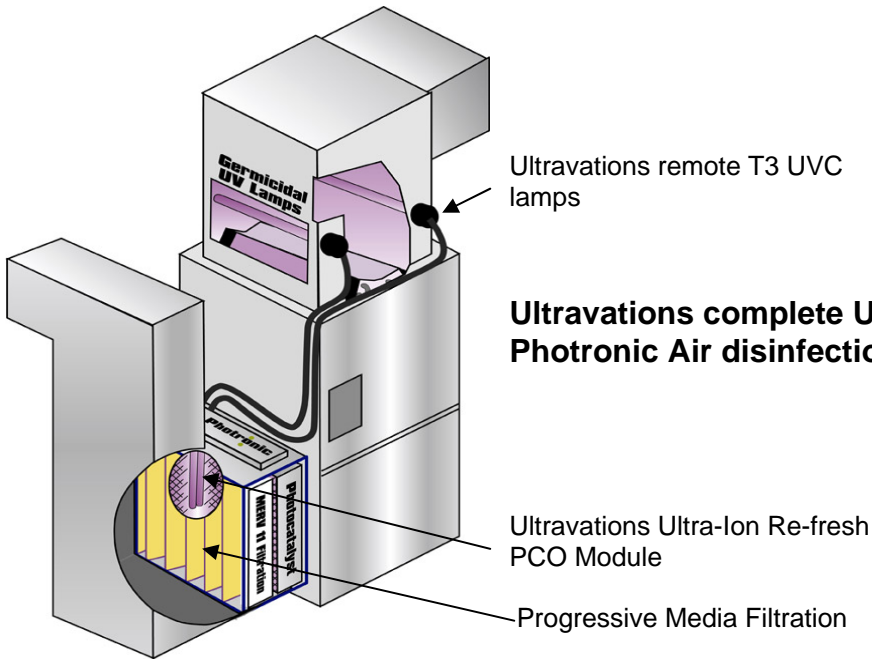

**Ultravations complete Upgraded Photronic Air disinfection system**

- | <b>Photronic Electrical Housings</b>                          |
|---|
| 1. Photronic Electronics Upgrade no Remote UVC (94-001)       |
| 2. Photronic Electronics Upgrade with 12" Remote UVC (94-002) |
| 3. Photronic Electronics Upgrade with 17" Remote UVC (94-003) |

**Upgrade Options and Replacement Components**

Models	Photronic Electronics Housing	1" MERV-11 Filters	5" MERV-11 Filters	Re-fresh PCO Filter
	<b>*See List Above</b>			
90-005	Not Upgradeable	NA	NA	NA
90-006 / 90-037	1,2,3	91-020 MERV-11	91-005 MERV-11	91-031
90-007 / 90-036	1,2,3	91-021 MERV-11	91-006 MERV-11	91-030
90-015 / 90-039	1,2,3	91-023 MERV-11	91-012 MERV-11	91-034
90-016 / 90-038	1,2,3	91-022 MERV-11	91-013 MERV-11	91-032

**Replacement filters:**

Models	1" MERV-11 Replacement Filters	5" MERV-11 Replacement Filters
90-005	91-021 MERV-11	NA
90-006 / 90-037	91-020 MERV-11	91-005 MERV-11
90-007 / 90-036	91-021 MERV-11	91-006 MERV-11
90-015 / 90-039	91-023 MERV-11	91-012 MERV-11
90-016 / 90-038	91-022 MERV-11	91-013 MERV-11

**\*(See Serial Number Label inside of equipment door for unit replacement part numbers)**

**Warranty:**

Ultravation warrants this product against any defects in material or workmanship for a period of 10 years after date of purchase, with the exception of the disposable pleated media filter, the ductwork and installation.

This warranty does not include damage to the unit from accident, misuse or improper installation. If this product should become defective during the warranty period, Ultravation will elect to repair or replace the product free of charge. Ultravation will return repaired or replaced warranted products pre-paid, provided that the product was delivered pre-paid.

Ultravation shall have no responsibilities for charges incurred by the customer for installation or removal of warranted items. Liability is limited only to the replacement or repair of this product.

This warranty gives you specific legal rights, and you may also have other rights, which vary from state to state. All returns must be accompanied by a return authorization number, which may be obtained by contacting Ultravation, Inc.

Ultravation, Inc. ~ P.O. Box 165 ~ 212 Ideal Way ~ Poultney, Vermont 05764  
Phone: 802-287-9735 ~ Fax: 802-287-9203~ [www.ultravation.com](http://www.ultravation.com)