

This Owner's Manual is provided and hosted by [Appliance Factory Parts](#).



# Kenmore 721.67602790 Owner's Manual

[Shop genuine replacement parts for Kenmore  
721.67602790](#)

## DOOR PARTS

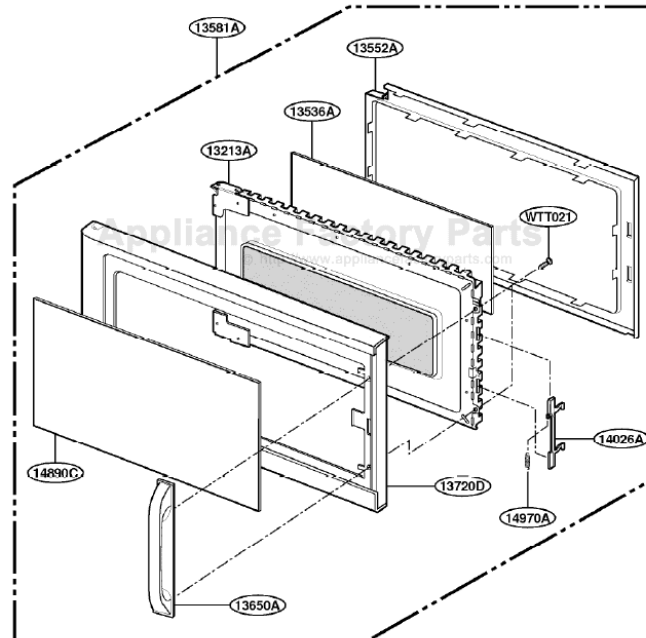

[Find Your Kenmore Microwave Parts - Select From 532 Models](#)

----- Manual continues below -----

## 8. PROCEDURE FOR MEASURING MICROWAVE ENERGY LEAKAGE

### A. CAUTIONS

- (1) Be sure to check a microwave emission prior to servicing the oven if the oven is operative prior to servicing.
- (2) The service personnel should inform the manufacturer, importer, or assembler of any certified oven unit found to have a microwave emission level in excess of  $5 \text{ mW/cm}^2$  and should repair any unit found to have excessive emission levels at no cost to the owner and should ascertain the cause of the excessive leakage. The service personnel should instruct the owner not to use the unit until the oven has been brought into compliance.
- (3) The service personnel should check all surface and vent openings for microwave emission testing.
- (4) Check for microwave energy leakage after every servicing. The power density of the microwave radiation leakage emitted by the microwave oven should not exceed  $2 \text{ mW/cm}^2$ . And always start measuring of an unknown field to assure safety for operating personnel from radiation leakage.

### EQUIPMENT

- (1) Electromagnetic energy leakage monitor (NARDA 8100B, HOLADAY HI 1501).
- (2) 600cc glass beaker.
- (3) Glass thermometer  $100^\circ\text{C}$  or  $212^\circ\text{F}$ .

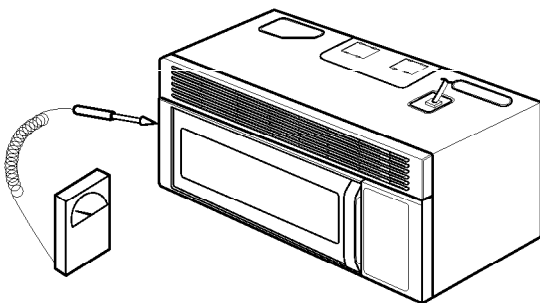

Figure 6

### B. MEASURING MICROWAVE ENERGY LEAKAGE

- (1) Pour  $275 \pm 15\text{cc}$  of  $20 \pm 5^\circ\text{C}$  water in a beaker which is graduated to 600 cc, and place the beaker in the center of the oven.
- (2) Set the energy leakage monitor to 2,450 MHz and use it following the manufacturer's recommended test procedure to assure correct result.
- (3) When measuring the leakage, always use the 2 inch (5cm) spacer supplied with the probe.
- (4) Operate the oven at its maximum output.
- (5) Measure the microwave radiation using and electromagnetic radiation monitor by holding the probe perpendicular to the surface being measured.

### C. MEASUREMENT WITH THE OUTER CASE

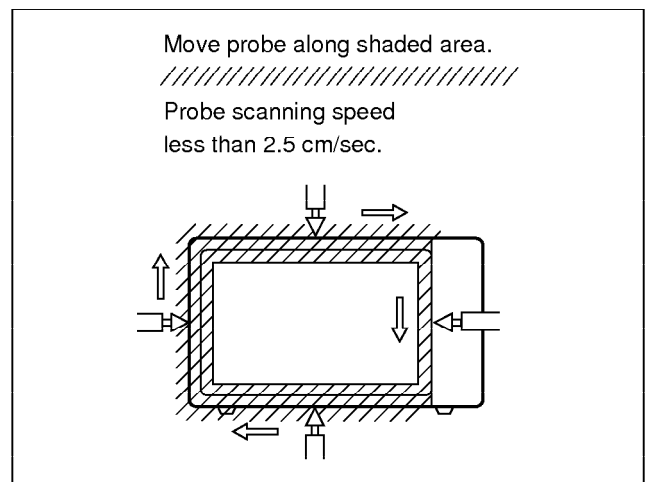

Figure 7

### REMOVED

- (1) When you replace the magnetron, measure for microwave energy leakage before the outer case is installed and after all necessary components are replaced or adjusted. Special care should be taken in measuring the following parts.
  - Around the magnetron
  - The waveguide

**WARNING:** AVOID CONTACTING ANY HIGH VOLTAGE PARTS.

#### D. MEASUREMENT WITH A FULLY ASSEMBLED OVEN

- (1) After all components, including the outer panels, are fully assembled, measure for microwave energy leakage around the door viewing window, the exhaust opening and air inlet openings.
- (2) Microwave energy leakage must not exceed the values prescribed below.

##### NOTES:

Leakage with the outer panels removed - less than 5 mW/cm<sup>2</sup>.

Leakage for a fully assembled oven ("Before the latch switch (primary) is interrupted") with the door in a slightly opened position - less than 2 mW/cm<sup>2</sup>.

#### E. NOTE WHEN MEASURING

- (1) Do not exceed meter full scale deflection.
- (2) The test probe must be removed no faster than 1 inch/sec (2.5cm/sec) along the shaded area, otherwise a false reading may result.
- (3) The test probe must be held with the grip portion of the handle. A false reading may result if the operator's hand is between the handle and the probe.
- (4) When testing near a corner of the door, keep the probe perpendicular to the surface making sure the probe horizontally along the oven surface, this may possibly cause probe damage.

#### F. RECORD KEEPING AND NOTIFICATION AFTER MEASUREMENT

- (1) After adjustment and repair of any microwave energy interruption or microwave energy blocking device, record the measured values for future reference. Also enter the information on the service invoice.
- (2) Should the microwave energy leakage not be more than 2 mW/cm<sup>2</sup> after determining that all parts are in good condition, functioning properly and genuine replacement parts which are listed in this manual have been used.
- (3) At least once a year, have the electromagnetic energy leakage monitor checked for calibration by its manufacturer.

#### G. POWER OUTPUT MEASUREMENT

- (1) Microwave power output measurement is made with the microwave oven supplied at its rated voltage and operated at its maximum microwave power setting with a load of (1000±5) g of potable water.
- (2) The water is contained in a cylindrical borosilicate glass vessel having a maximum material thickness of 1/8" (3 mm) and an outside diameter of approximately 7.6" (190mm).
- (3) The oven and the empty vessel are at ambient temperature prior to the start of the test.
- (4) The initial temperature (T<sub>1</sub>) of the water is (10±2)°C (50°F) It is measured immediately before the water is added to the vessel. After addition of the water to the vessel, the load is immediately placed on the center of the turntable which is in the lowest position and the microwave power switched on.
- (5) The time T for the temperature of the water to rise by a value ΔT of (10±2)°K is measured, where T is the time in seconds and ΔT is the temperature rise. The initial and final water temperatures are selected so that the maximum difference between the final water temperature and the ambient temperature is 5°K.
- (6) The microwave power output P in watts is calculated from the following formula :

$$P = \frac{4187 \times (\Delta T)}{T}$$

is measured while the microwave generator is operating at full power. Magnetron filament heat-up time is not included. (about 3 sec)

- (7) The water is stirred to equalize temperature throughout the vessel, prior to measuring the final water temperature.
- (8) Stirring devices and measuring instruments are selected in order to minimize addition or removal of heat.

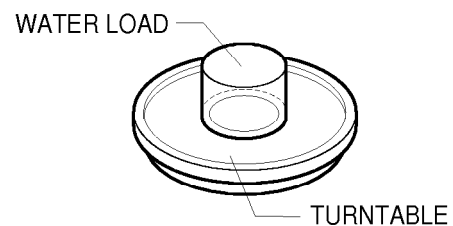

## 9. DISASSEMBLY INSTRUCTIONS

### IMPORTANT NOTES:

UNIT MUST BE DISCONNECTED FROM ELECTRICAL OUTLET WHEN MAKING REPAIRS, REPLACEMENTS, ADJUSTMENTS AND CONTINUITY CHECKS. WAIT AT LEAST ONE MINUTE, UNTIL THE HIGH VOLTAGE CAPACITOR IN THE HIGH VOLTAGE POWER SUPPLY HAS FULLY DISCHARGED.

THE CAPACITOR SHOULD BE DISCHARGED BY USING INSULATED WIRE - I.E. TEST PROBE CONNECTED TO 10K-OHM RESISTOR IN SERIES TO GROUND.

WHEN RECONNECTING THE WIRE LEADS TO ANY PART, MAKE SURE THE WIRING CONNECTIONS AND LEAD COLORS ARE CORRECTLY MATCHED ACCORDING TO THE OVERALL CIRCUIT DIAGRAM. (ESPECIALLY SWITCHES AND HIGH VOLTAGE CIRCUIT.)

### A. REMOVING POWER AND CONTROL CIRCUIT BOARD (Figures 8, 9 and 10)

- (1) Remove 1 screw securing the control panel assembly to the oven cavity. (Figure 8)
- (2) Remove the control panel with pushing it upward.
- (3) Remove the two connectors (CN1, CN2) and wire leads (Relay2) from the circuit board.

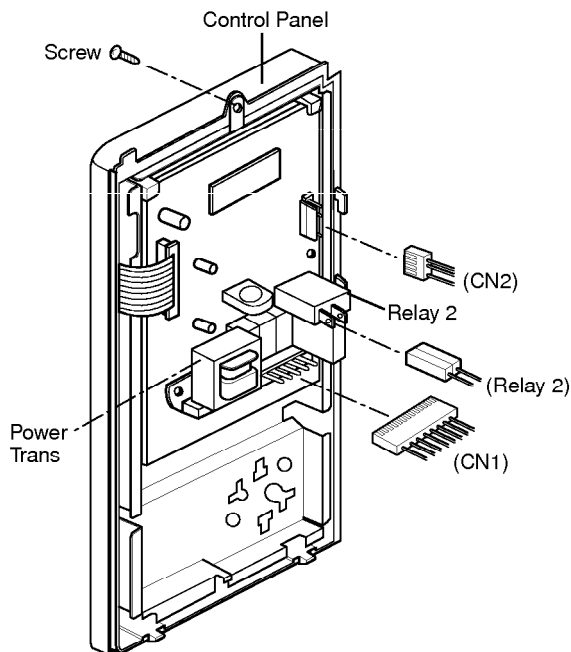

Figure 8

- (4) Remove 3 screws securing the circuit board. (Figure 9)

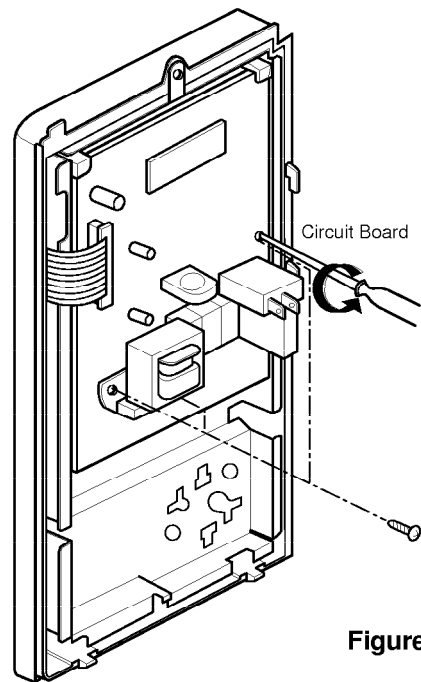

Figure 9

- (5) Remove the FPC connector from the terminal socket following "HOW TO REMOVE THE FPC CONNECTOR" on the next page.
- (6) Remove the circuit board from the control bracket carefully.

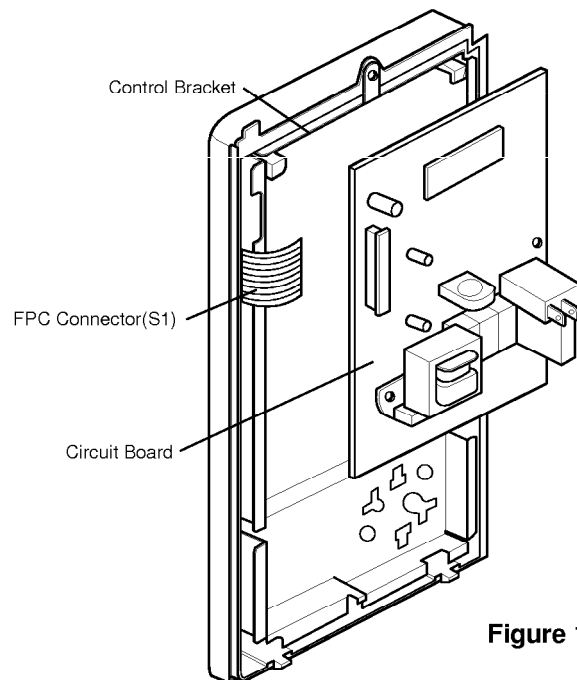

Figure 10

### HOW TO REMOVE THE F.P.C. CONNECTOR

Follow the steps below as illustrated in Figures 11 and 12 to remove the F.P.C. connector.

- (1) Hold the edges of the plastic fastener with thumb and forefinger.  
(Figure 11)
- (2) Lift up the lever of the plastic fastener from the terminal socket by lightly pressing the lever end with forefinger.  
(Figure 12)
- (3) Remove the F.P.C. connector from the terminal socket.

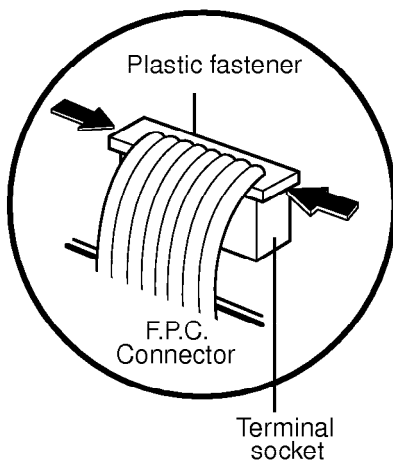

Figure 11

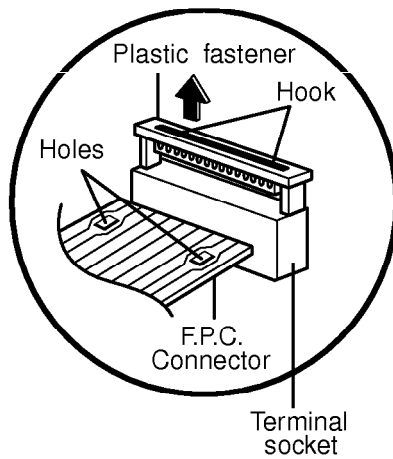

Figure 12

### HOW TO INSERT THE F.P.C. CONNECTOR

Follow the steps below as illustrated in Figures 13 and 14 to insert the F.P.C. connector.

- (1) Insert the F.P.C. connector into the terminal socket securely with the fingers.
- (2) Hold the plastic fastener with thumb and forefinger of the other hand, and push it slowly into the terminal socket. (Figure 13)

**NOTE:** When reconnecting the F.P.C. connector make sure that the holes on the F.P.C. connector are properly engaged with the hooks on the plastic fastener

- (3) Lock the level of the plastic fastener into the hook of the terminal socket securely by releasing the fingers.  
(Figure 14)

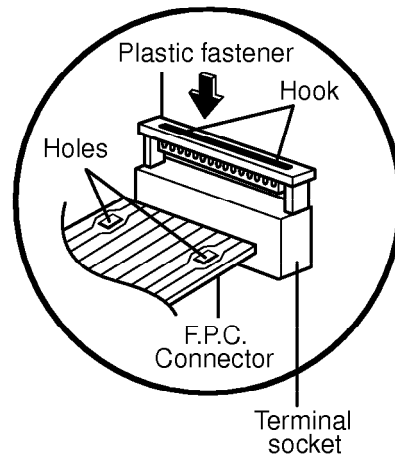

Figure 13

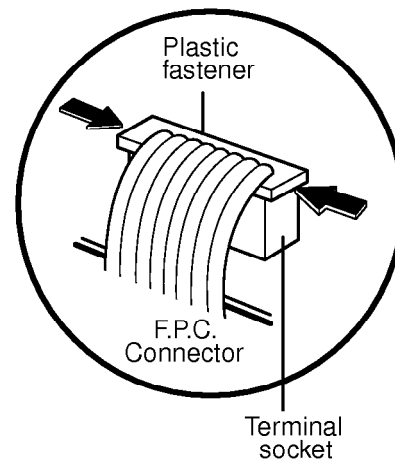
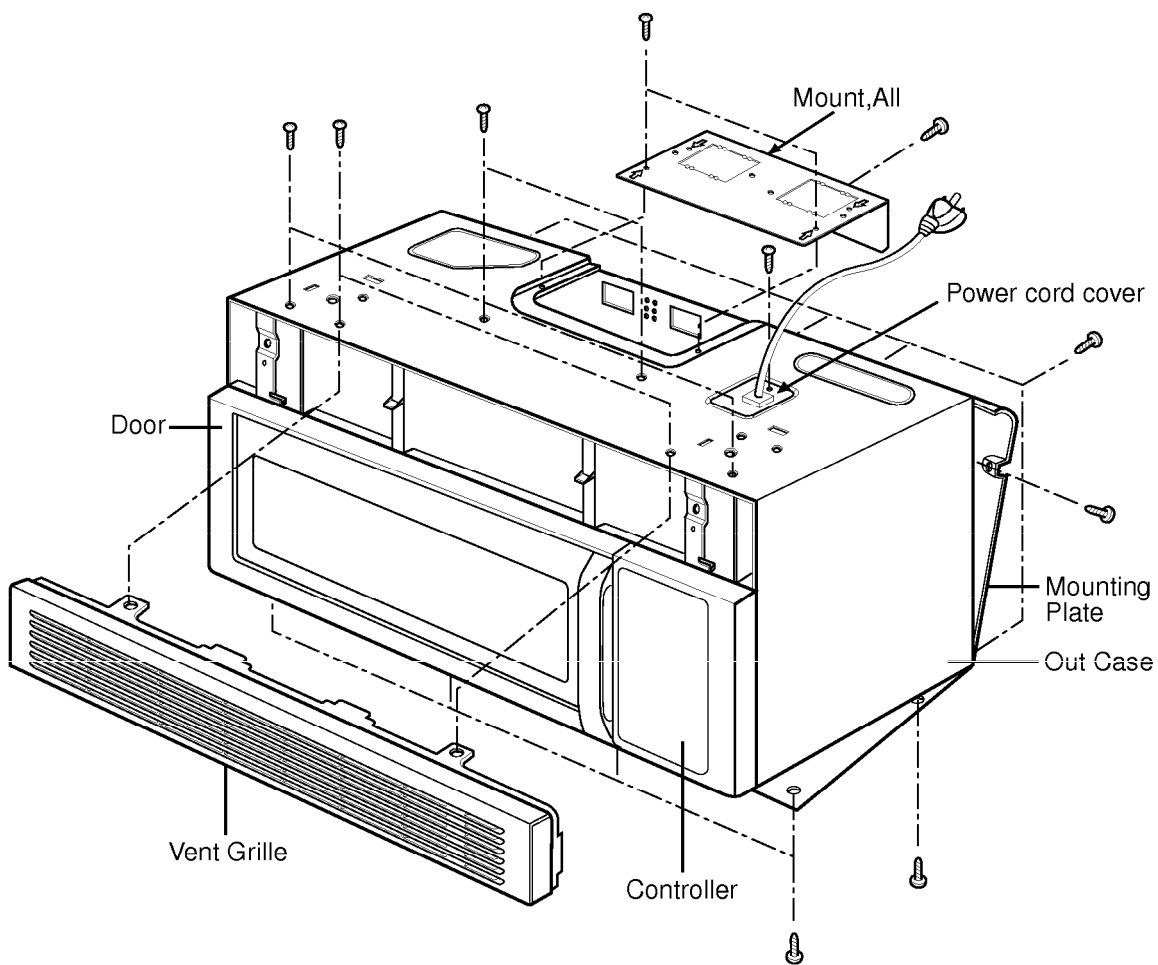

Figure 14

**B. REMOVING THE OUT CASE(Figure 15)**

- (1) Remove the vent grille by removing two screws securing it to the out case.
- (2) Remove two screws securing it to the front bracket.
- (3) Remove two screws securing it to the air duct.
- (4) Remove the mounting plate by turning the two screws securing it to the out case.
- (5) Remove the base plate by removing six screws securing it to the out case. Remove the Mount, All from the out case by removing two screws securing it to the out case and one screw securing it to the ventilation motor ASS'Y and cavity.
- (6) Remove the power cord cover from outcase by removing a screw.
- (7) Remove the power cord to the inner of the out case with turning power cord and remove the out case with pushing it back.

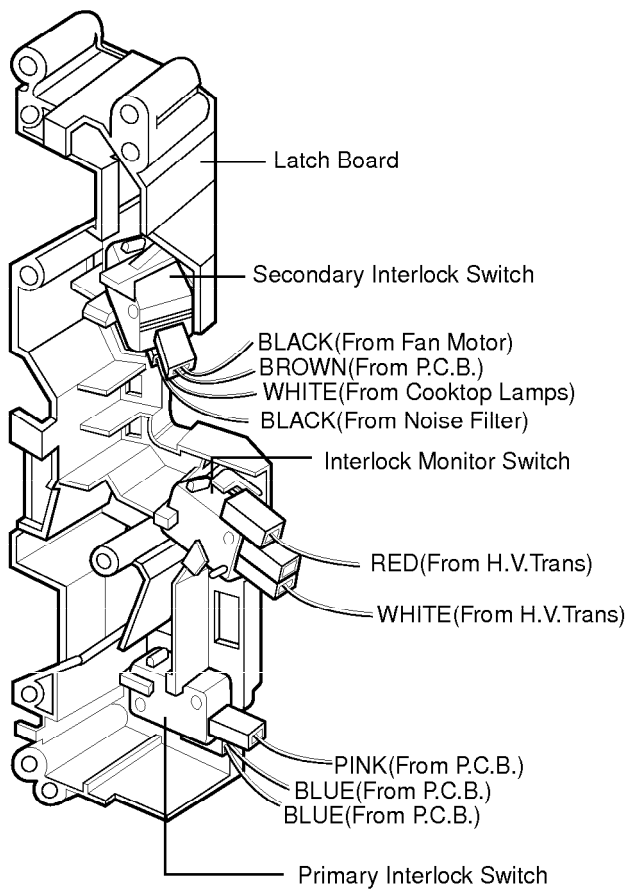

**Figure 15**

**C REMOVING THE PRIMARY INTERLOCK SWITCH, INTERLOCK MONITOR SWITCH AND SECONDARY INTERLOCK SWITCH**

**(Figures 16,17)**

- (1) Disconnect the wire leads from the interlock switches.
- (2) Remove two screws securing the Latch Board.
- (3) Make necessary replacements and check microwave energy leakage according to "1. ADJUSTMENT PROCEDURE" on page 3.



**Figure 16**

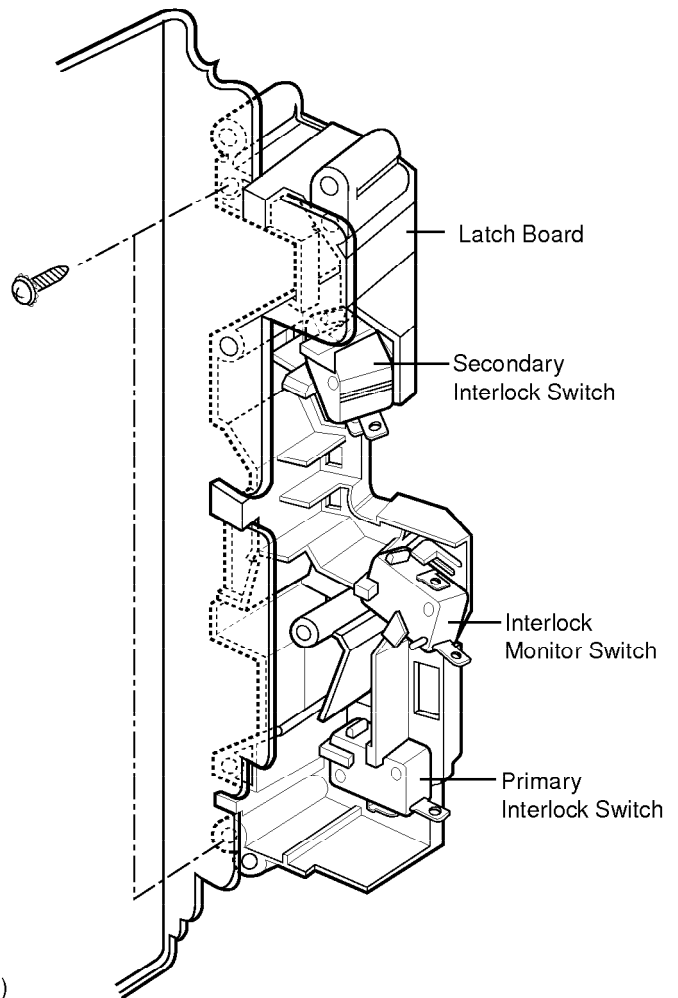

**Figure 17**

## E. REMOVING MAGNETRON

### (Figures 18 Through 21)

- (1) Remove the vent grille by removing two screws. (Figure 18)
- (2) Remove the controller by removing a screw and disconnect all wire leads. (Figure 18)
- (3) Remove the mount all from the out case by removing two screws securing it to the out case and one screw securing it to the ventilation motor ASS'Y and cavity. (Figure 19)
- (4) Remove the base plate by removing six screws securing it to the oven front plate and outcase, remove the outcase by removing nine screws securing it to the oven back plate, air duct, and front bracket. (Figure 20)
- (5) Remove four tap tite screws securing the magnetron to the wave guide. (Figure 21)
- (6) Remove the magnetron VERY CAREFULLY.

## NOTES:

- When removing the magnetron, make sure that its dome does not hit any adjacent parts, or it may be damaged.
- When replacing the magnetron, be sure to install the magnetron gasket in the correct position and be sure that the gasket is in good condition.
- After replacing the magnetron, check for microwave energy leakage with a survey meter. Check microwave energy leakage must be below the limit of 5mW/cm<sup>2</sup>. (All service adjustments should be made for minimum microwave energy leakage readings.)

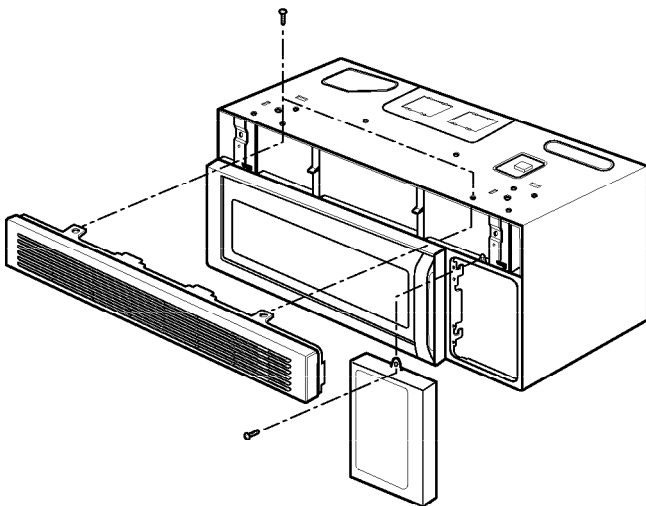

Figure 18

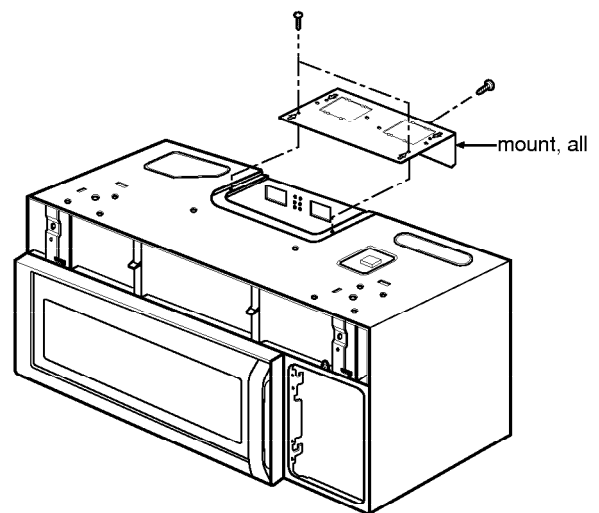

Figure 19

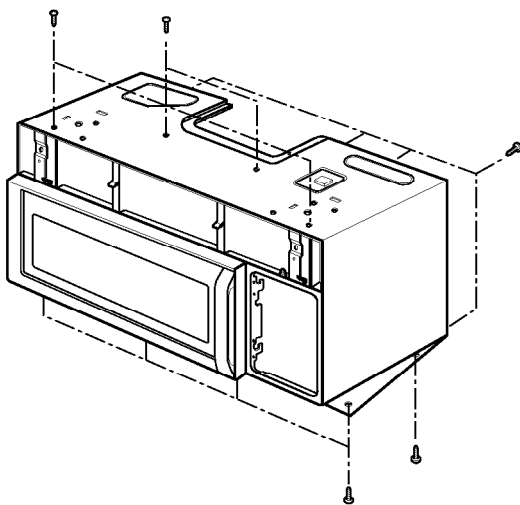

Figure 20

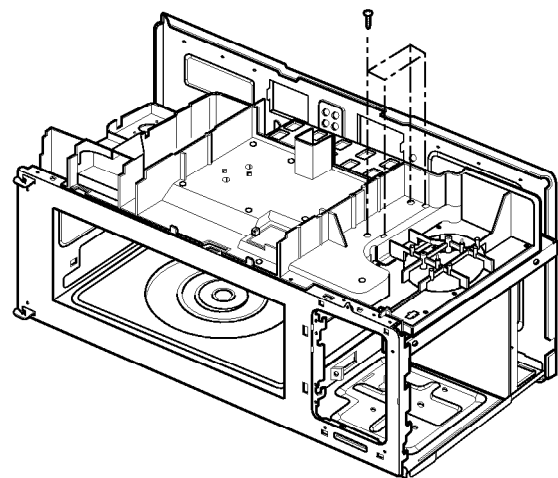

Figure 21

**F. REMOVING STIRRER FAN DISK  
(Figures 22 and 23)**

- (1) Remove 2 rivet ASS'Y securing it to the oven upper plate by using knife blade.
- (2) Pull out cover ASS'Y.
- (3) Remove the stirrer fan disk.

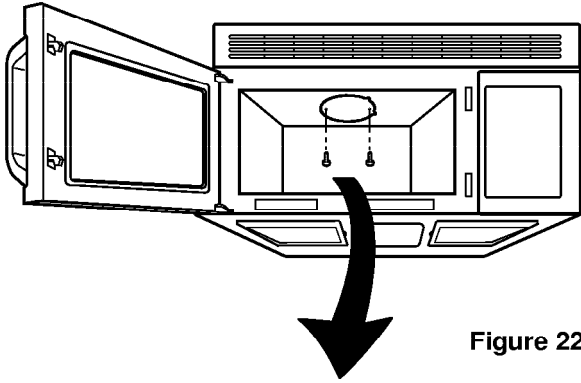

Figure 22

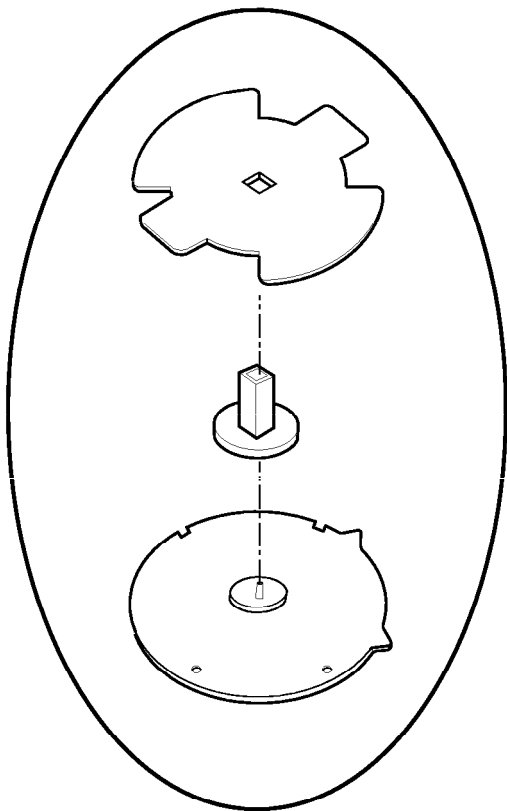

Figure 23

**G. REMOVING DOOR (Figure 24)**

- (1) Remove the vent grille by removing two screws securing it to the front bracket.
- (2) Lift up and push the door.

**NOTES:**

- After replacing the door, be sure to check that the primary interlock switch, the secondary interlock switch and the interlock monitor switch operate normally.
- After replacing the door, check for microwave energy leakage with a survey meter. Microwave energy leakage must be below the limit of 5mW/cm<sup>2</sup>. (With a 275 ml water load)

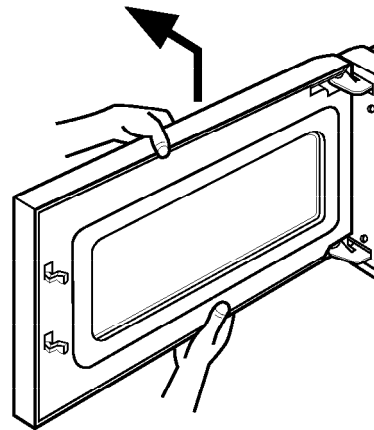

Figure 24

**H. DISASSEMBLING DOOR (Figure 25)**

- (1) Remove the dielectric choke by using knife blade or small screw driver, etc.
- (2) Remove two screws securing it to the door handle.

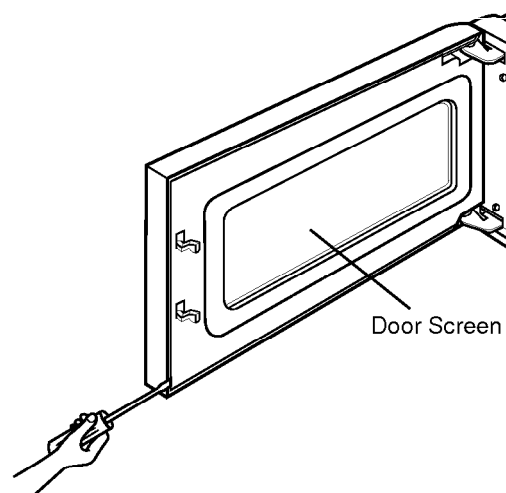

Figure 25

## I. REMOVING THE VENTILATION FAN ASS'Y

- (1) Remove the mounting plate by removing two screws securing it to the back plate.  
(See Figure 26)
- (2) Remove the two screws securing the MOUNT, ALL and one screw securing the ventilation fan ASS'Y. (See Figure 27)
- (3) Carefully pull the ventilation motor ASS'Y out of the microwave oven. (See Figure 28)
- (4) Disconnect the wire leads.

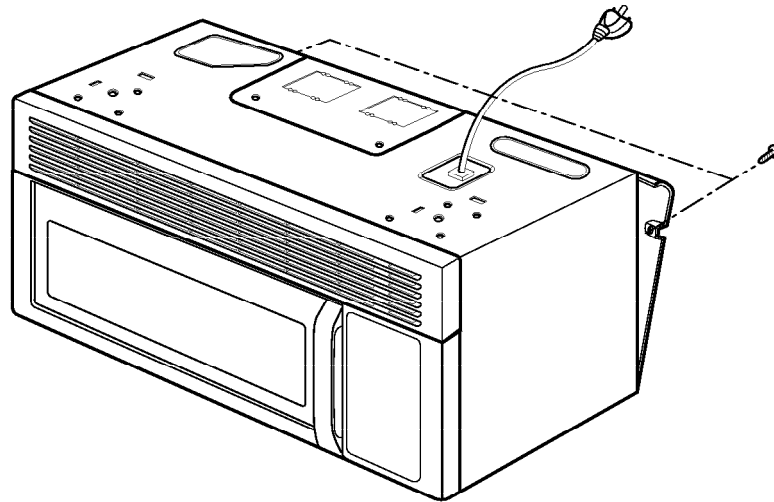

Figure 26

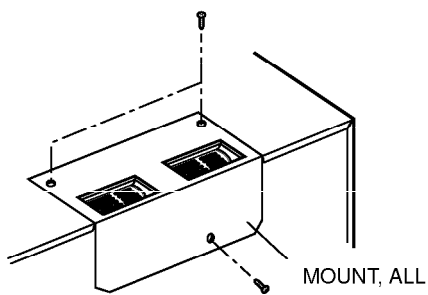

Figure 27

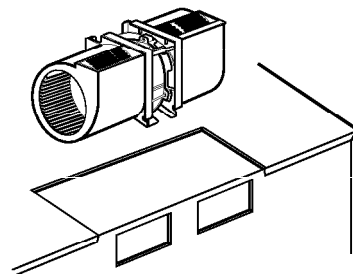

Figure 28

## J. REMOVING THE TURNTABLE MOTOR

- (1) Remove the turntable.
- (2) Remove the turntable shaft VERY CAREFULLY with a slotted screwdriver. (Figure 29)
- (3) Remove the base plate by removing 6 screws securing it to the oven cavity. (Figure 30)
- (4) Disconnect the leadwire from the turntable motor terminals.
- (5) Remove the 2 screws securing the turntable motor to the oven cavity ASS'Y. (Figure 31)

### NOTES:

- Remove the leadwire from the turntable motor VERY CAREFULLY.
- Be sure to grasp the connector not the wires when removing.

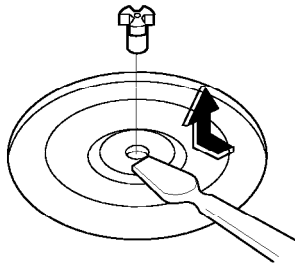

Figure 29

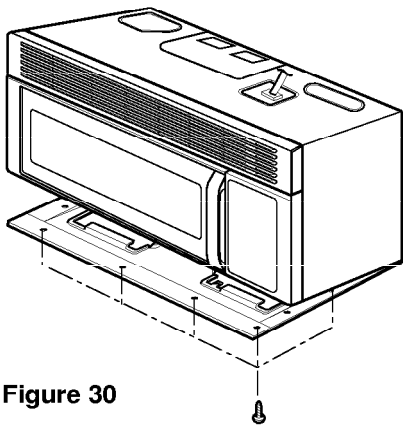

Figure 30

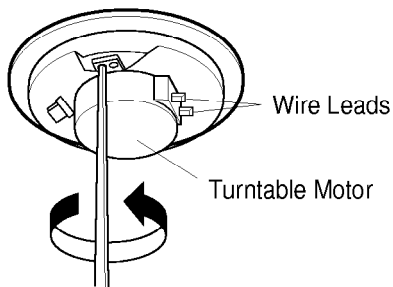

Figure 31

## K. REMOVING THE STIRRER FAN MOTOR

- (1) Remove all screws from out case and remove the out case.
- (2) Remove 6 screws securing the air duct to the oven cavity, and remove 2 screws securing the stirrer fan motor to the bracket. (Figure 32)
- (3) Lift the air duct and disconnect the leadwire from the stirrer fan motor. (Figure 33)
- (4) Remove the stirrer fan motor.

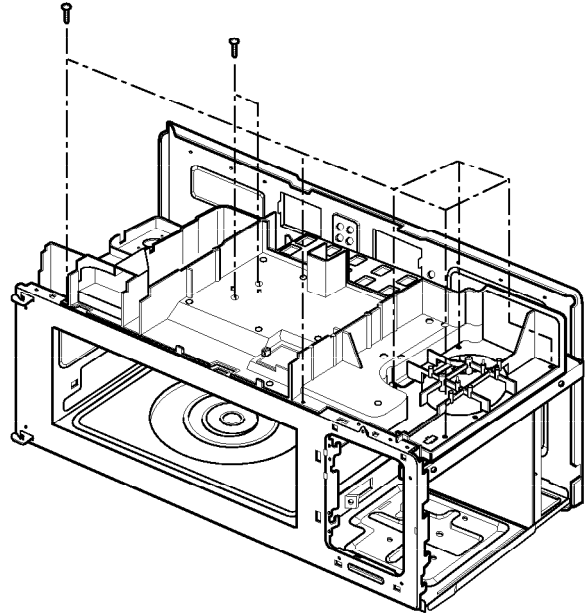

Figure 32

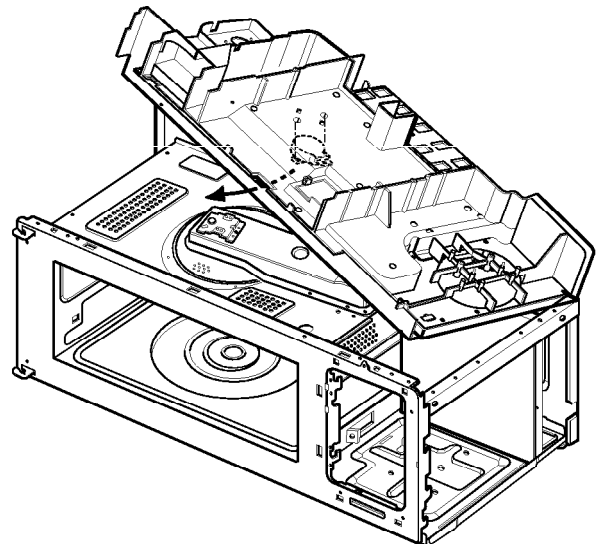

Figure 33

## 10. PRECAUTIONS AND REPAIR SERVICE TIPS

### PRELIMINARY

#### A. SINCE NEARLY 2,100 VOLTS EXISTS IN SOME CIRCUITS OF THIS UNIT REPAIRS SHOULD BE CARRIED OUT WITH GREAT CARE.

The filament leads of magnetron carry High Voltage with respect to ground. Extreme caution must be exercised. Never plug the unit into a power source to determine which component is defective in high voltage section.

#### B. TO AVOID POSSIBLE EXPOSURE TO MICROWAVE ENERGY LEAKAGE, THE FOLLOWING PRECAUTIONS MUST BE TAKEN BEFORE SERVICING.

- (1) Before the power is applied:
  - (a) Make sure the primary interlock switch, the secondary interlock switch and the interlock monitor switch operate properly by opening and closing the door several by opening and closing the door several times.
  - (b) Make sure the perforated screen and the dielectric choke of the door are correctly and firmly mounted.
- (2) After power is applied:
  - (a) Make sure the interlock switch mechanism is operating properly by opening and closing the door.
  - (b) Check microwave energy leakage must be below the limit of  $5\text{mW}/\text{cm}^2$ .  
(All service adjustments should be made for minimum microwave energy leakage readings).

- (3) Do not operate the unit until it is completely repaired, if any of the following conditions exist. The unit must not be operated.

- (a) The door does not close firmly.
- (b) The hinge is broken.
- (c) The door seal is damaged.
- (d) The door is bent or warped, or there is any other visible damage on the unit that may cause microwave energy leakage.

**NOTE:** Always keep the seal clean.

- (e) Make sure that there are no defective parts in the interlock mechanism.
- (f) Make sure that there are no defective parts in the microwave generating and transmission assembly (especially waveguide).

- (4) The following items should be checked after the unit is repaired:

- (a) The interlock monitor switch is connected correctly and firmly.
- (b) The magnetron gasket is properly positioned and mounted.
- (c) The waveguide and the oven cavity are intact. (no microwave energy leakage)
- (d) The door can be properly closed and the safety switches work properly.
- (e) The unit must stop when the door is opened or the time is up.

The unit must not be operated with any of the above components removed or by-passed.

## 11. TEST AND CHECKOUT PROCEDURES, AND TROUBLESHOOTING

### - CAUTIONS -

- DISCONNECT THE POWER SUPPLY CORD FROM THE WALL OUTLET WHENEVER REMOVING THE CABINET FROM THE UNIT. PROCEED WITH THE TESTS ONLY AFTER DISCHARGING THE HIGH VOLTAGE CAPACITOR AND REMOVING THE WIRE LEADS FROM THE PRIMARY WINDING OF THE HIGH VOLTAGE TRANSFORMER. (SEE FIGURE 34)
- ALL OPERATIONAL CHECKS WITH MICROWAVE ENERGY MUST BE DONE WITH A LOAD (1 LITER OF WATER IN CONTAINER) IN THE OVEN.

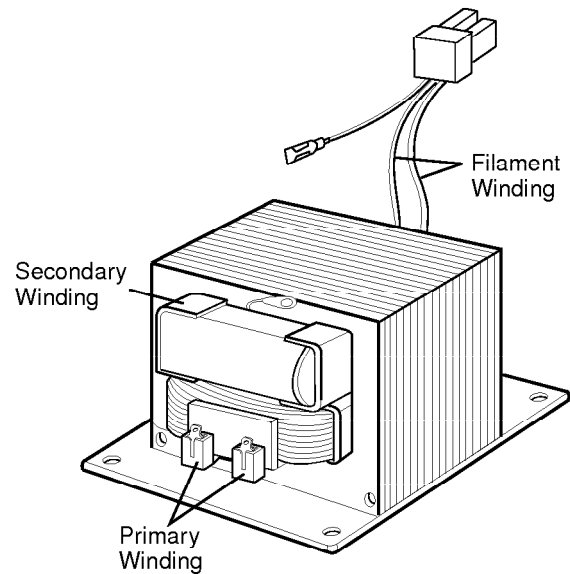
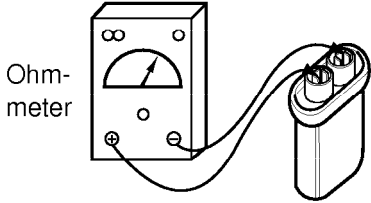
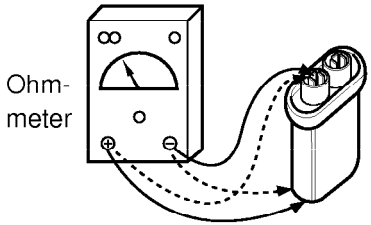
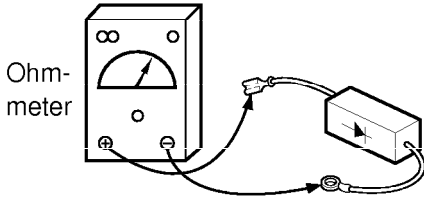
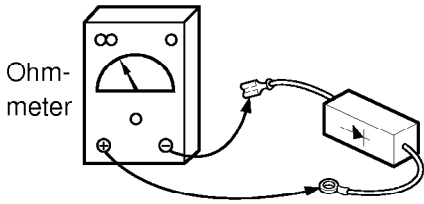

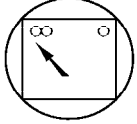
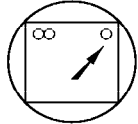
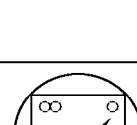

Figure 34

### A. TEST PROCEDURES

COMPONENTS	TEST PROCEDURES	RESULTS
MAGNETRON (Wire leads are removed)	<ol style="list-style-type: none"> <li>1) Measure the resistance: Across the filament terminals of the magnetron with an ohm-meter on Rxl scale.</li> <li>2) Measure the resistance: Between each filament terminal of the magnetron and the chassis ground with an ohm-meter on high test scale.</li> </ol>	<p>Normal reading: Less than 1 ohm.</p> <p>Normal reading: Infinite ohms.</p> <p><b>NOTE:</b> Replace the magnetron, if the magnetron checks and all of the high voltage component tests are good, but the unit still does not heat a load.</p>
HIGH-VOLTAGE TRANSFORMER (Wire leads are removed)	<ol style="list-style-type: none"> <li>1) Measure the resistance: With an ohm-meter on Rxl scale.               <ol style="list-style-type: none"> <li>a. Primary winding;</li> <li>b. Filament winding;</li> <li>c. Secondary winding;</li> </ol> </li> <li>2) Measure the resistance: With an ohm-meter on highest scale.               <ol style="list-style-type: none"> <li>a. Primary winding to ground;</li> <li>b. Filament winding to ground;</li> </ol> </li> </ol>	<p>Normal readings: Approx. 0.44 ohm. Less than 0.1 ohm. Approx. <math>105 \pm 5</math> ohms.</p> <p>Normal readings: Infinite ohms. Infinite ohms.</p>

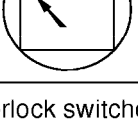

**NOTE:** A MICROWAVE ENERGY LEAKAGE TEST MUST ALWAYS BE PERFORMED WHEN THE UNIT IS SERVICED FOR ANY REASON.

COMPONENTS	TEST PROCEDURES	RESULTS
HIGH-VOLTAGE CAPACITOR	Measure the resistance: (1) Terminal to terminal   <b>Figure 35-a</b>	Normal reading: Momentarily indicates several ohms, and then gradually returns to infinite ohms.  Abnormal reading: Indicates continuity or infinite ohms from the beginning.
	(2) Terminal to case   <b>Figure 35-b</b>	Normal readings: Infinite.  Abnormal reading: Indicates continuity.
HIGH-VOLTAGE DIODE	Measure the continuity: (1) Forward   <b>Figure 36-a</b>	Normal readings: continuity.  Abnormal reading: Infinite.
	(1) Reverse   <b>Figure 36-b</b>	Normal readings: Infinite.  Abnormal reading: continuity.

COMPONENTS	TEST PROCEDURES		RESULTS													
<p style="text-align: center;">SWITCHES (Wire leads are removed)</p>	Check for the continuity of the switch with an ohm-meter.		DOOR OPEN	DOOR CLOSED												
	Secondary Interlock	Terminals "COM" and "NO" of switch														
	Primary Interlock	Terminals "COM" and "NO" of switch														
	Interlock Monitor	Terminals "COM" and "NC" of switch														
	<ul style="list-style-type: none"> <li>The service personnel should replace all of the monitored safety interlock switches and monitor switch if the oven has been rendered inoperative due to the failure of the monitored safety interlock(s).</li> <li>Be sure to connect the monitor switch after replacement and to check interlock monitor continuity.</li> </ul> <p><b>NOTE:</b> After checking for the continuity of switches make sure that they are correctly connected.</p>															
CIRCUIT BOARD	See page 28 for "CHECKOUT PROCEDURES FOR THE CIRCUIT BOARD"															
TEMPERATURE PROBE	Measure the resistance: With an ohm-meter on highest scale.		Normal readings: <table border="1" data-bbox="1008 1234 1450 1473" style="margin-left: auto; margin-right: auto;"> <thead> <tr> <th>Ambient temperature</th> <th>Resistance values</th> </tr> </thead> <tbody> <tr> <td>60 °F</td> <td>75.24 Kohm ± 11K</td> </tr> <tr> <td>68 °F (20 °C)</td> <td>62.57 Kohm ± 8K</td> </tr> <tr> <td>70 °F</td> <td>59.79 Kohm ± 8K</td> </tr> <tr> <td>80 °F</td> <td>45.80 Kohm ± 7K</td> </tr> <tr> <td>90 °F</td> <td>36.94 Kohm ± 6K</td> </tr> </tbody> </table>		Ambient temperature	Resistance values	60 °F	75.24 Kohm ± 11K	68 °F (20 °C)	62.57 Kohm ± 8K	70 °F	59.79 Kohm ± 8K	80 °F	45.80 Kohm ± 7K	90 °F	36.94 Kohm ± 6K
	Ambient temperature	Resistance values														
60 °F	75.24 Kohm ± 11K															
68 °F (20 °C)	62.57 Kohm ± 8K															
70 °F	59.79 Kohm ± 8K															
80 °F	45.80 Kohm ± 7K															
90 °F	36.94 Kohm ± 6K															
<p><b>NOTE:</b> If the thermistor in temperature probe is open or short-circuited, the symptoms will be shown in the display window as explained in "NOTE of PROBLEM-F under TROUBLESHOOTING" on page 33.</p>																

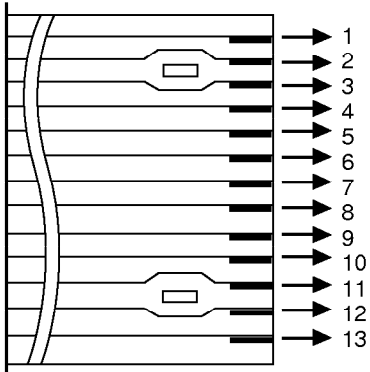
NOTE: A MICROWAVE ENERGY LEAKAGE TEST MUST ALWAYS BE PERFORMED WHEN THE UNIT IS SERVICED FOR ANY REASON.

COMPONENTS	TEST PROCEDURES	RESULTS																																																													
TOUCH KEY BOARD	<p>Measure the resistance between terminal pins of connector KEY CON.</p> <p><b>NOTE:</b> When reconnecting the FPC connector, make sure that the holes on the FPC connector are properly engaged with hooks on the plastic fastener.</p> <p style="text-align: center;">MATRIX CIRCUIT FOR TOUCH KEY BOARD CONNECTOR(KEY CON)</p> <table border="1" data-bbox="448 707 927 1122"> <thead> <tr> <th></th> <th>1</th> <th>2</th> <th>3</th> <th>4</th> <th>5</th> <th>6</th> <th>7</th> </tr> </thead> <tbody> <tr> <th>8</th> <td>FAN HI/LOW/OFF</td> <td>HELP</td> <td>AUTO COOK</td> <td>POPCORN</td> <td>TIME</td> <td>5</td> <td>0</td> </tr> <tr> <th>9</th> <td>LIGHT HI/LOW/OFF</td> <td>CUSTOM SELECT</td> <td>AUTO REHEAT</td> <td>POTATO</td> <td>AUTO DEFROST</td> <td>6</td> <td>1</td> </tr> <tr> <th>10</th> <td>N.C</td> <td>CLOCK</td> <td>N.C</td> <td>BEVERAGE</td> <td>KITCHEN TIMER</td> <td>7</td> <td>2</td> </tr> <tr> <th>11</th> <td>MEMORY</td> <td>LIGHT TIMER</td> <td>TEMP</td> <td>BACON</td> <td>POWER CONTROL</td> <td>8</td> <td>3</td> </tr> <tr> <th>12</th> <td>TURN TABLE ON/OFF</td> <td>STOP/CLEAR</td> <td>START</td> <td>QUICK ON</td> <td>HOLD</td> <td>9</td> <td>4</td> </tr> <tr> <th>13</th> <td>N.C</td> <td>N.C</td> <td>N.C</td> <td>N.C</td> <td>N.C</td> <td>N.C</td> <td>N.C</td> </tr> </tbody> </table> <p style="text-align: center;"><b>Figure 39</b></p>		1	2	3	4	5	6	7	8	FAN HI/LOW/OFF	HELP	AUTO COOK	POPCORN	TIME	5	0	9	LIGHT HI/LOW/OFF	CUSTOM SELECT	AUTO REHEAT	POTATO	AUTO DEFROST	6	1	10	N.C	CLOCK	N.C	BEVERAGE	KITCHEN TIMER	7	2	11	MEMORY	LIGHT TIMER	TEMP	BACON	POWER CONTROL	8	3	12	TURN TABLE ON/OFF	STOP/CLEAR	START	QUICK ON	HOLD	9	4	13	N.C	N.C	N.C	N.C	N.C	N.C	N.C	<table border="1" data-bbox="970 248 1445 414"> <thead> <tr> <th rowspan="2">Resistance value</th> <th>When touched</th> <th>When not touched</th> </tr> </thead> <tbody> <tr> <td>Less than 400 ohms</td> <td>More than 1 mega ohm</td> </tr> </tbody> </table> <p style="text-align: center;">FPC CONNECTOR Top</p>  <p style="text-align: center;"><b>Figure 40</b></p>	Resistance value	When touched	When not touched	Less than 400 ohms	More than 1 mega ohm
	1	2	3	4	5	6	7																																																								
8	FAN HI/LOW/OFF	HELP	AUTO COOK	POPCORN	TIME	5	0																																																								
9	LIGHT HI/LOW/OFF	CUSTOM SELECT	AUTO REHEAT	POTATO	AUTO DEFROST	6	1																																																								
10	N.C	CLOCK	N.C	BEVERAGE	KITCHEN TIMER	7	2																																																								
11	MEMORY	LIGHT TIMER	TEMP	BACON	POWER CONTROL	8	3																																																								
12	TURN TABLE ON/OFF	STOP/CLEAR	START	QUICK ON	HOLD	9	4																																																								
13	N.C	N.C	N.C	N.C	N.C	N.C	N.C																																																								
Resistance value	When touched	When not touched																																																													
	Less than 400 ohms	More than 1 mega ohm																																																													

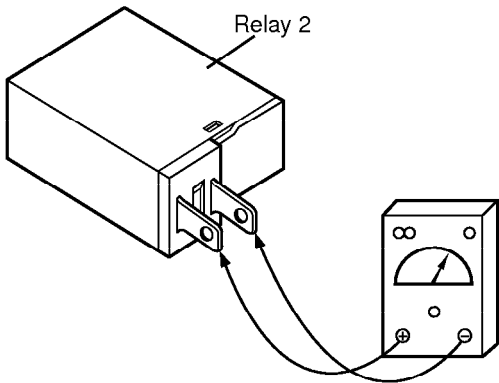
COMPONENTS	TEST PROCEDURES	RESULTS		
		POWER LEVEL	$\infty$  $\circ$	$\infty$  $\circ$
RELAY2	Check for continuity of relay 2 with an ohm-meter. (Remove wire leads from relay 2 and operate the unit.)   <b>Figure 42</b>	1	4 sec	18 sec
		2	6 sec	16 sec
		3	8 sec	14 sec
		4	10 sec	12 sec
		5	12 sec	10 sec
		6	14 sec	8 sec
		7	16 sec	6 sec
		8	18 sec	4 sec
		9	20 sec	2 sec
		10	22 sec	0

**NOTES:**

- A MICROWAVE ENERGY TEST MUST ALWAYS BE PERFORMED WHEN THE UNIT IS SERVICED FOR ANY REASON.
- MAKE SURE THE WIRE LEADS ARE IN THE CORRECT POSITION.
- WHEN REMOVING THE WIRE LEADS FROM THE PARTS, BE SURE TO GRASP THE CONNECTOR, NOT THE WIRES.

**B. CHECKOUT PROCEDURES**

(1) CHECKOUT PROCEDURES FOR FUSE BLOWING

**CAUTION:**REPLACE BLOWN FUSE WITH 20 AMPERE FUSE.

PROBLEMS	CAUSES
Fuse blows immediately after the door is closed.	Improper operation of the primary interlock, secondary interlock switches and/or the interlock monitor switch.
Fuse blows immediately after the door is opened.	
Fuse blows when the door is closed and START key is touched.	Malfunction of the high voltage transformer; the high voltage capacitor including the diode, the magnetron, the blower motor or the circuit board.

**NOTES:**

- If the fuse is blown by an improper switch operation, replace the defective switches and the fuse at the same time. After replacing the defective switches with new ones, make sure that they are correctly connected.
- Check for microwave energy leakage according to "1. ADJUSTMENT PROCEDURES" on page 3,4 when the primary interlock, secondary interlock switches and/or the interlock monitor switches are adjusted or replaced.

(2) CHECKOUT PROCEDURES FOR RELAY.

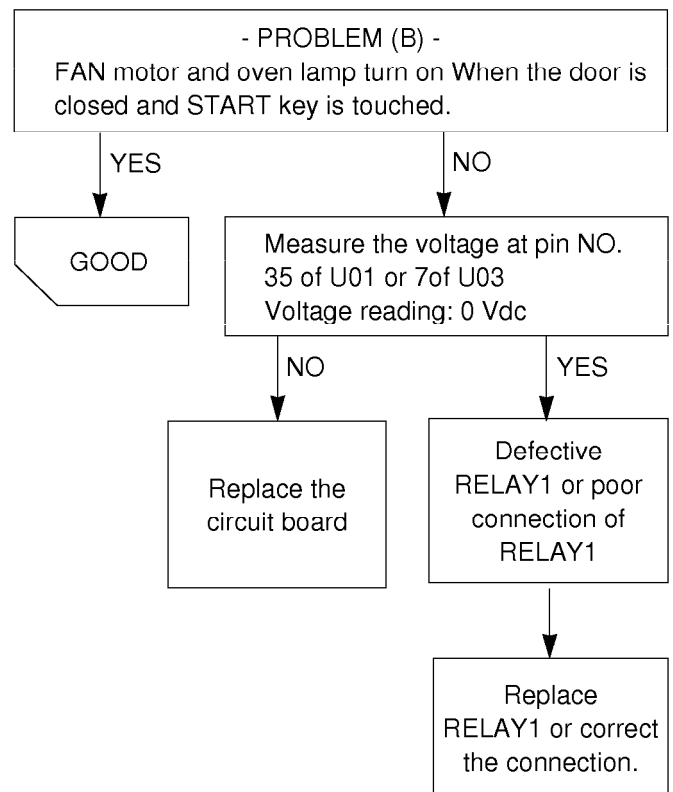
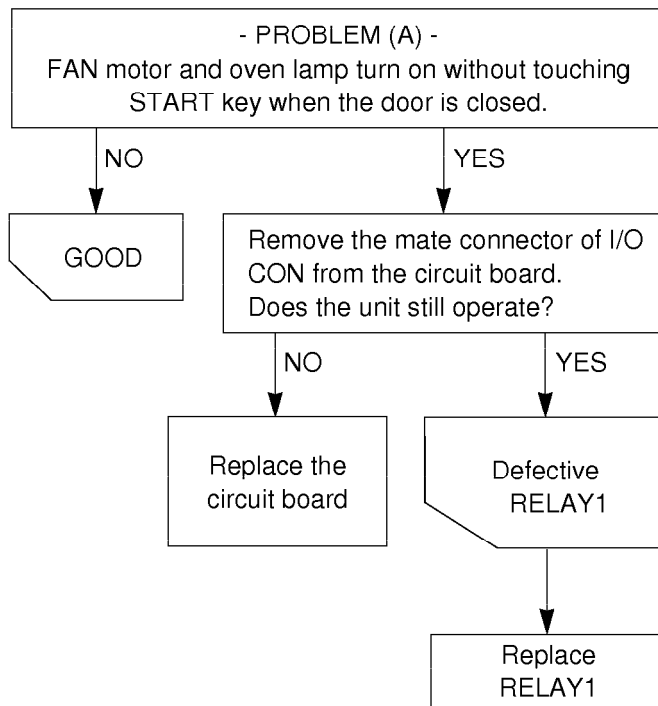

(3) CHECKOUT PROCEDURES FOR CIRCUIT BOARD

The following symptoms indicate a defective circuit board.

- 1) The start function fails to operate but the high voltage Systems, the interlock switches, the door sensing and the relay check good.
- 2) The unit with a normal relay continuously operates.
- 3) Proper temperature measurement is not obtained.
- 4) The buzzer does not sound or continues to sound.
- 5) Some segments of one or more digits do not light up, or they continue to light up, or segments light when they should not.
- 6) Wrong figures appear.
- 7) The figures of all digits.
- 8) Some of the indicators do no flicker light up.
- 9) The clock does not keep time properly.

**NOTE:** A MICROWAVE ENERGY LEAKAGE TEST MUST ALWAYS BE PERFORMED WHEN THE UNIT IS SERVICED FOR ANY REASON.

# SCHEMATIC DIAGRAM FOR MICOM CONTROLLER

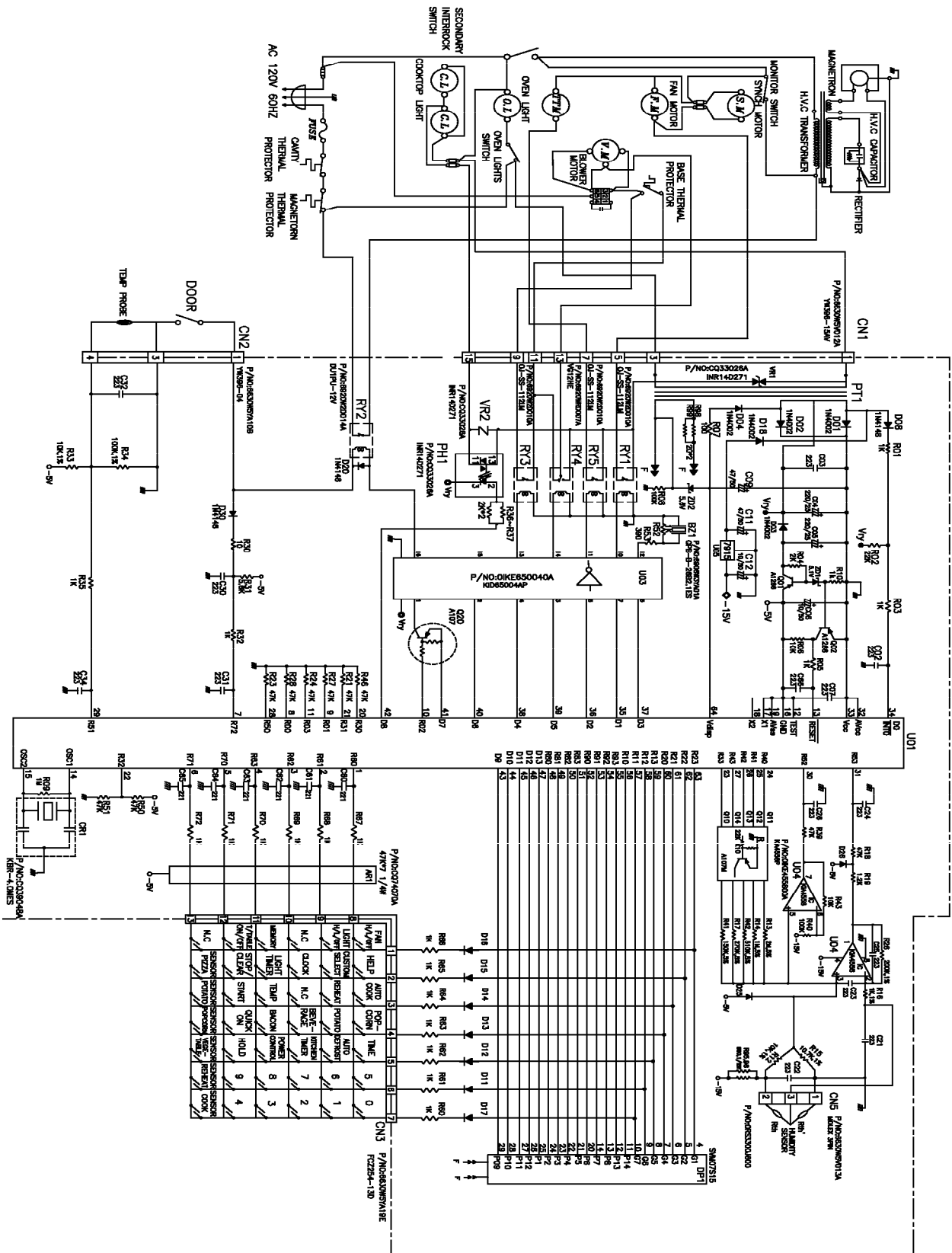

**C. TROUBLESHOOTING**

Before following this troubleshooting read "TRIAL OPERATION" on page 5.

f u "DISPLAY" Problems, "A" thru "C"      f u "TEMPERATURE CONTROLLED COOKING" Problems, "F"  
 f u "HELP UP" Problems, "D" thru "E"      f u "BUZZER Problems, "G"

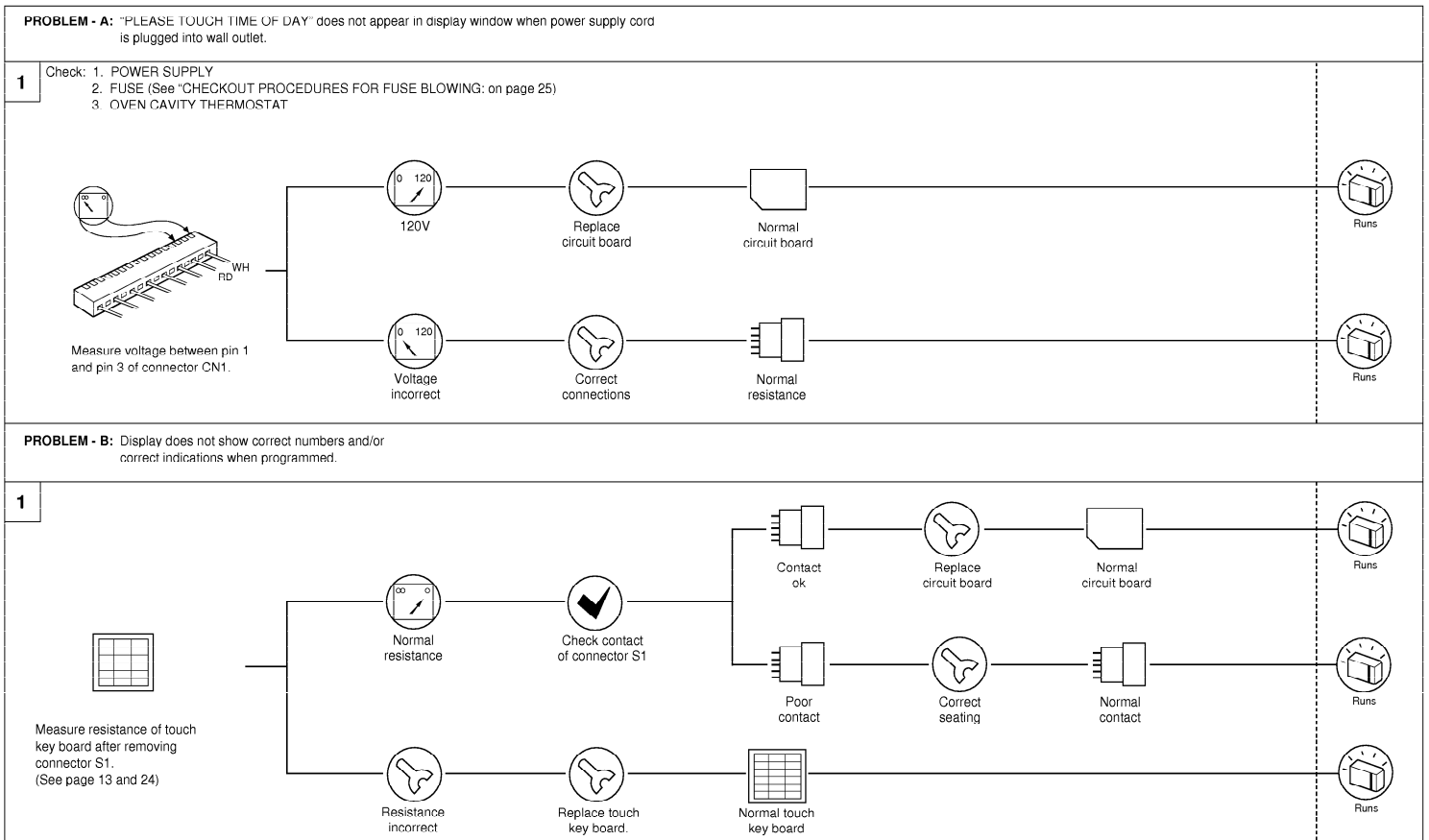

**PROBLEM - C:** Display does not start countdown when START key is touched.

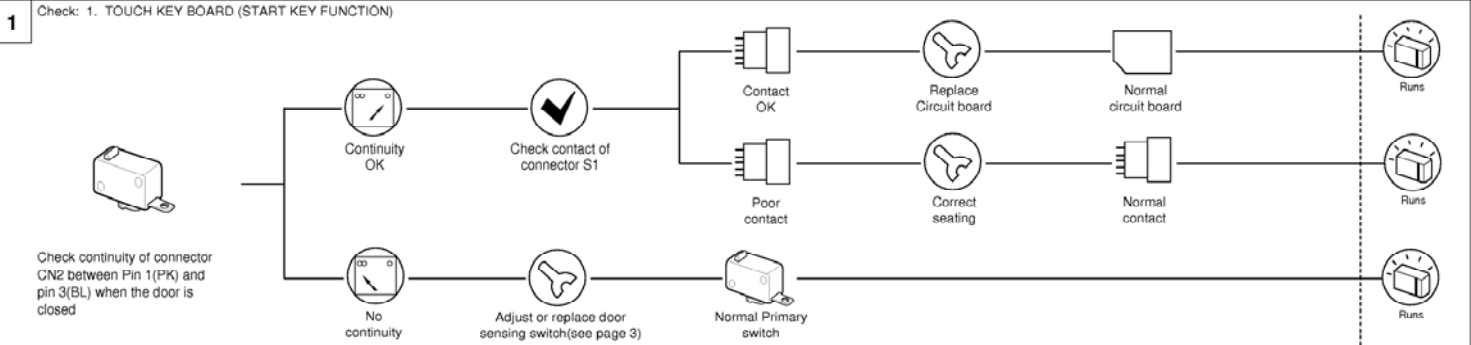

**PROBLEM - D:** Unit operation seems to be normal but little or no heating is produced in oven load.

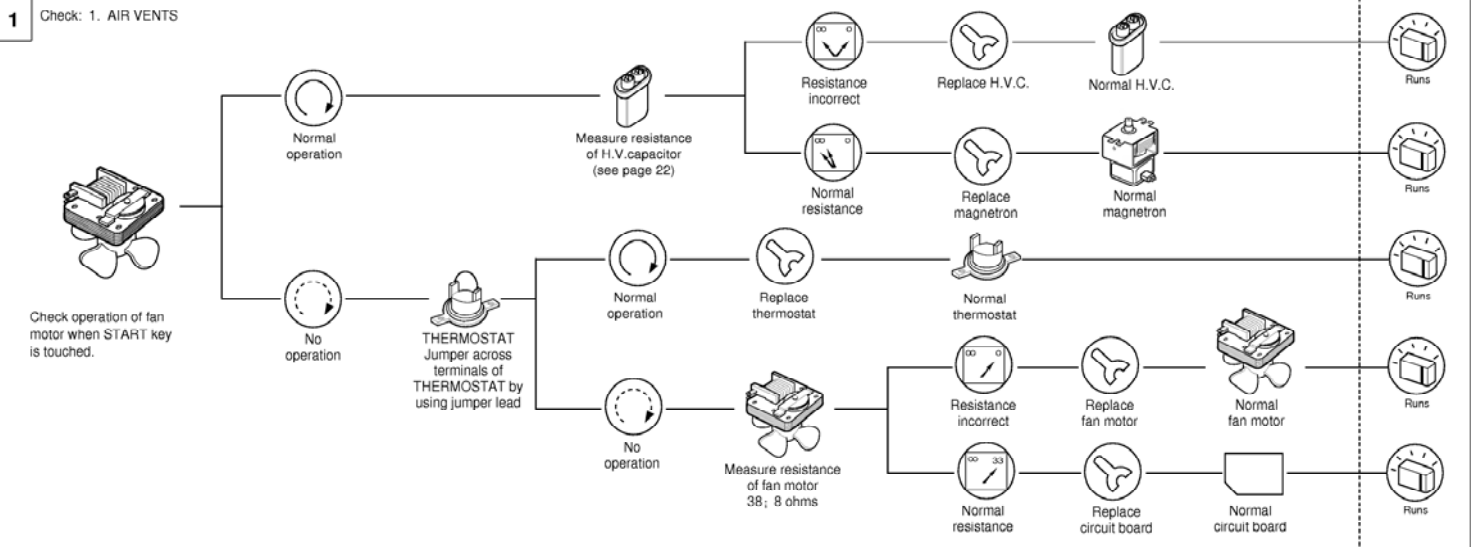

**PROBLEM - E:** Unit does not heat up even if display counts down when START key is touched for "HIGH POWER" cooking.

- 1** Check: 1. PRIMARY AND SECONDARY INTERLOCK SWITCHES  
2. THERMOSTAT

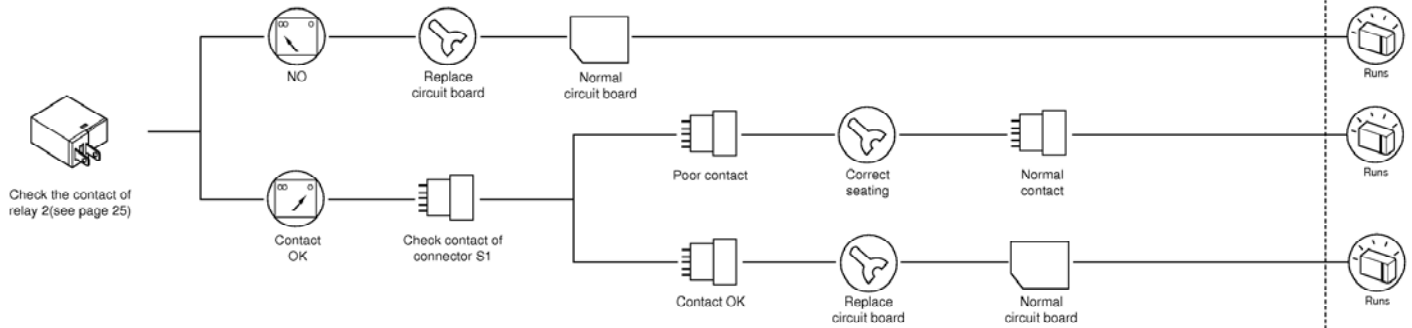

**2**

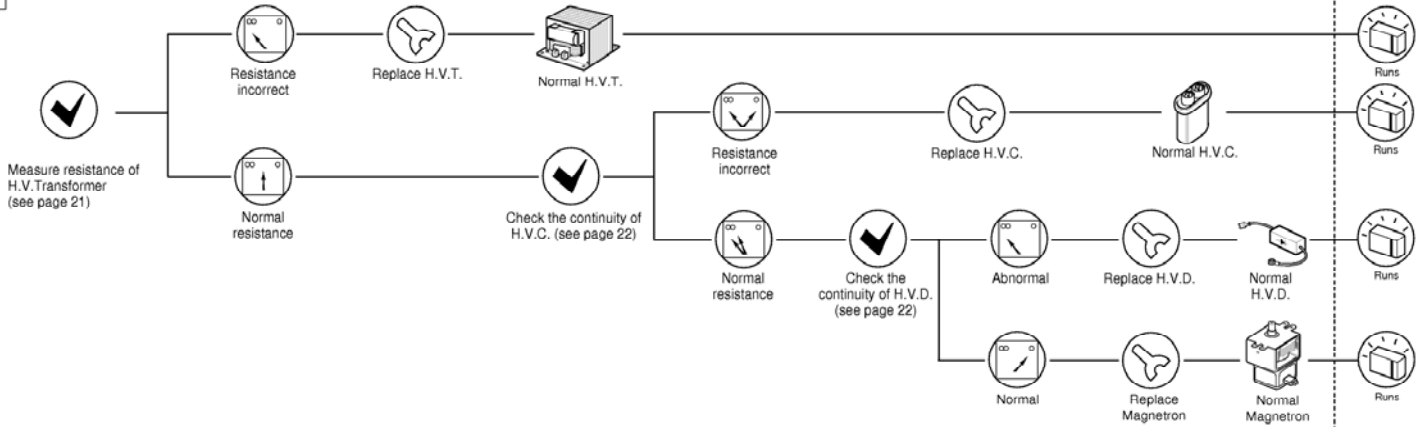

**PROBLEM - F:** Unit does not cook properly when Temperature controlled cooking is set.

1

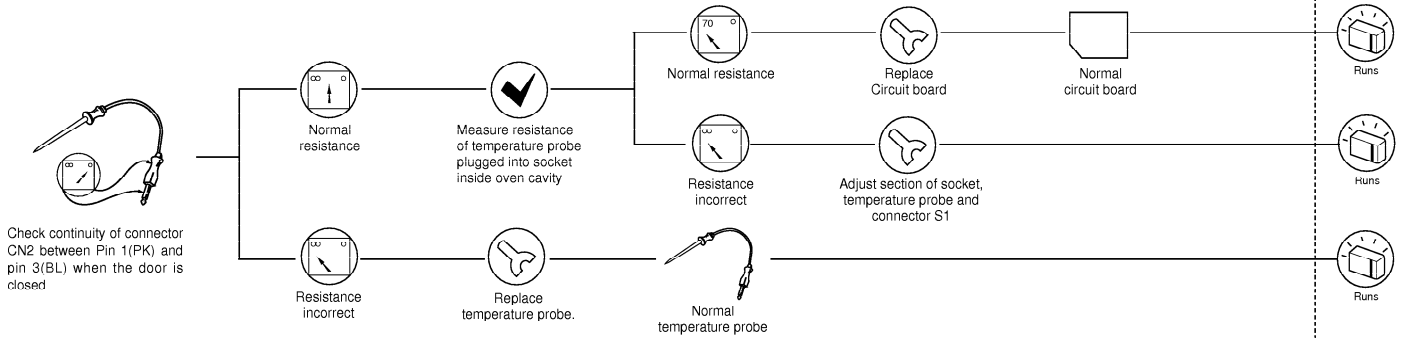

**NOTE**

- When the thermistor in temperature probe is open, the display window will continuously show "LOW F" even if the unit becomes overheated by continuous ON of the magnetron.
- When it is short-circuited, the display window will show "End" even if the magnetron does not operate.

**PROBLEM - G:** No buzzing when touching the key, between stages or at end of cooking

1

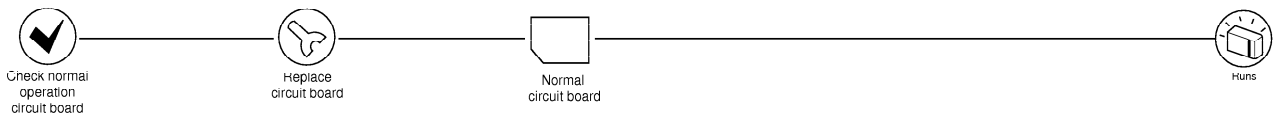

**PROBLEM - H:** Ventilation fan does not operate when "FAN HIGH/LOW" key is touched.

**1**

Check: 1. POWER SUPPLY  
2. FUSE

