

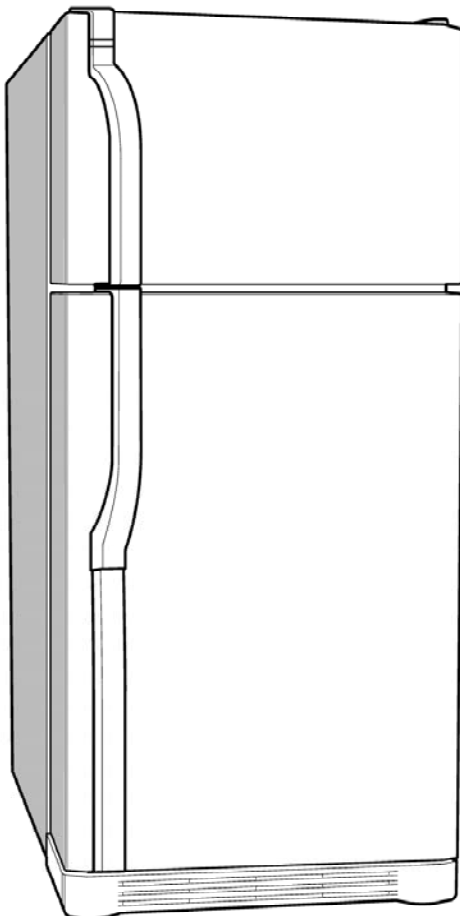

REFRIGERATOR SERVICE MANUAL

CAUTION
BEFORE SERVICING THE UNIT,
READ THE SAFETY PRECAUTIONS IN THIS MANUAL.



Model #s:

795-73962303
795-73969303
795-73964303
795-73966303
795-73963303
795-75952401
795-75959401
795-73262303
795-73264303
795-73263303
795-75259401
795-75954401
795-73269303
795-73266303
795-75252401
795-75254401

CONTENTS

SAFETY PRECAUTIONS	2
SPECIFICATIONS	3
PARTS IDENTIFICATION	4
DISASSEMBLY	5-6
DOOR.....	5
DOOR SWITCH.....	5
FAN AND FAN MOTOR.....	6
DEFROST CONTROL ASSEMBLY.....	6
LAMP.....	6
CONTROL BOX-REFRIGERATOR.....	6
ADJUSTMENT	7-8
COMPRESSOR.....	7
PTC-STARTER.....	7
OLP(OVERLOAD PROTECTOR)	8
THERMOSTAT.....	8
CIRCUIT DIAGRAM	9-10
TROUBLESHOOTING	11-16
COMPRESSOR AND ELECTRICAL COMPONENTS	11
PTC AND OLP	12
OTHER ELECTRICAL COMPONENTS	13
SERVICE DIAGNOSIS CHART.....	14
REFRIGERATION CYCLE.....	15-16
OPERATION PRINCIPLE & REPAIR METHOD OF ICE MAKER	17-20
DESCRIPTION OF FUNCTION & CIRCUIT OF MICOM	21-35
REFRIGERATOR EXPLODED VIEW & SERVICE PARTS LIST	36

SAFETY PRECAUTIONS

Please read the following instructions before servicing your refrigerator.

1. Check the refrigerator for electrical faults.
2. To prevent electric shock, unplug before servicing.
3. Always check line voltage and amperage.
4. Use standard electrical components or cause your skin to freeze and stick to the surfaces inside the freezer.
5. Don't touch metal products in the freezer with wet hands. This may cause frostbite.
6. Prevent water from spilling onto electrical elements or the machine parts.
7. Close the top door before opening the bottom door. Otherwise, you might hit your head when you stand up.
8. When tilting the refrigerator, remove any material on the refrigerator, especially the glass shelves and stored food.
9. When servicing the evaporator, wear cotton gloves. This is to prevent injuries from the sharp evaporator fins.
10. Service on the refrigerators should be performed by a qualified technician. Sealed system repair must be performed by a CFC certified technician.

1. SPECIFICATIONS

1-1 DISCONNECT POWER CORD BEFORE SERVICING IMPORTANT D RECONNECT ALL GROUNDING DEVICES

All parts of this appliance capable of conducting electrical current are grounded. If grounding wires, screws, straps, clips, nuts or washers used to complete a path to ground are removed for service, they must be returned to their original position and properly fastened.

1-2 IMPORTANT NOTICE

This information is intended for use by individuals possessing adequate backgrounds of electrical, electronic and mechanical experience. Any attempt to repair a major appliance may result in personal injury and property damage. The manufacturer or seller cannot be responsible for the interpretation of this information, nor can it assume any liability in connection with its use.

1-3 ELECTRICAL SPECIFICATIONS

Temperature Control (Position : MID) 8-(-6)°F
 Defrost Control 7 hrs.
 Defrost Thermostat 50°F
 Electrical Rating :115V. AC, 60 Hz. 1-5 Amp.
 Maximum Current Leakage 0.5 mA
 Maximum Ground Path Resistance 0.14 Ohms
 Energy Consumption ...20 cu.ft : 482 kWh/yr(Energy star, 520kWh/yr
22 cu.ft : 494 kWh/yr(Energy star), 530kWh/yr

1-4 NO LOAD PERFORMANCE CONTROL POSITION: MID/MID

And Ambient of :70°F90°F
 Fresh Food, °F33°F to 41°F 33°F to 41°F
 Frozen Food, °F(-4°F) to 4°F (-4°F) to 4°F
 Percent Running Time25%-35% 45%-60%

PERFORMANCE DATA (NORMAL OPERATING CONDITIONS)			
AMB	WATTS	SYSTEM PRESSURE (PSIG)	
		HIGH SIDE	LOW SIDE
70°F	98 (+10 / -10)	97 (+5 / -3)	(-5) to (-2)
90°F	98 (+10 / -10)	130 (+3 / -3)	(-4) to 1
110°F	103 (+5 / -5)	174 (+5 / -5)	(-2) to 3

1-5 REFRIGERATION SYSTEM

Minimum Compressor Capacity Vacuum 21 in.
 Minimum Equalized Pressure
 @ 70°F 49 PSIG
 @ 90°F 56 PSIG
 Refrigerant - R - 134a 4.05 oz.....(21cu.ft.....5.47oz)
 Compressor700BTU/hr

1-6 INSTALLATION

Clearance must be provided at top, sides and rear of the refrigerator for air circulation.

AT TOP 1 in
 AT SIDES 1/8 in
 AT REAR 1 in

1-7 REPLACEMENT PARTS

Relay 6749C-0008D
 Overload 6750C-0004S
 Defrost Thermostat 6615JB2005C
 Defrost Heater 20cu. ft : 5300JB1001D
 22cu. ft : 5300JB1100J
 Evaporator Fan Motor 4680JK1002B
 Capacitor OCZZJB2003H
 Compressor (Hi-Side) 2521JJ8007A
 Evaporator (Lo-Side) 20cu. ft : 5421JJ1001A
 22cu. ft : 5421JJ1001B
 Condenser 5403JJ1005A,4A
 Dryer 5851JJ2002B
 Condenser Fan Motor 4681JK1001B
 Temperature Control 6871JB2047A,46B
 Main Control..... 6871JB1215A,13A

1-8 AIR FLOW / CIRCULATION D' AIR

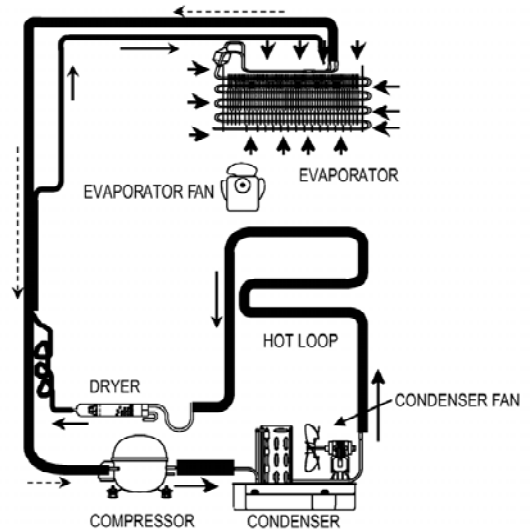

21cu.ft..... 5.47 oz.

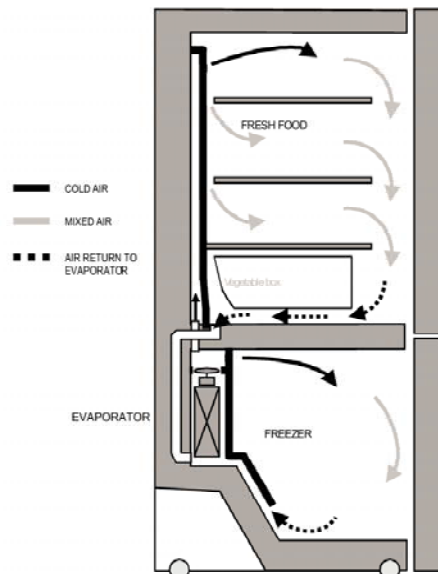

2. PARTS IDENTIFICATION

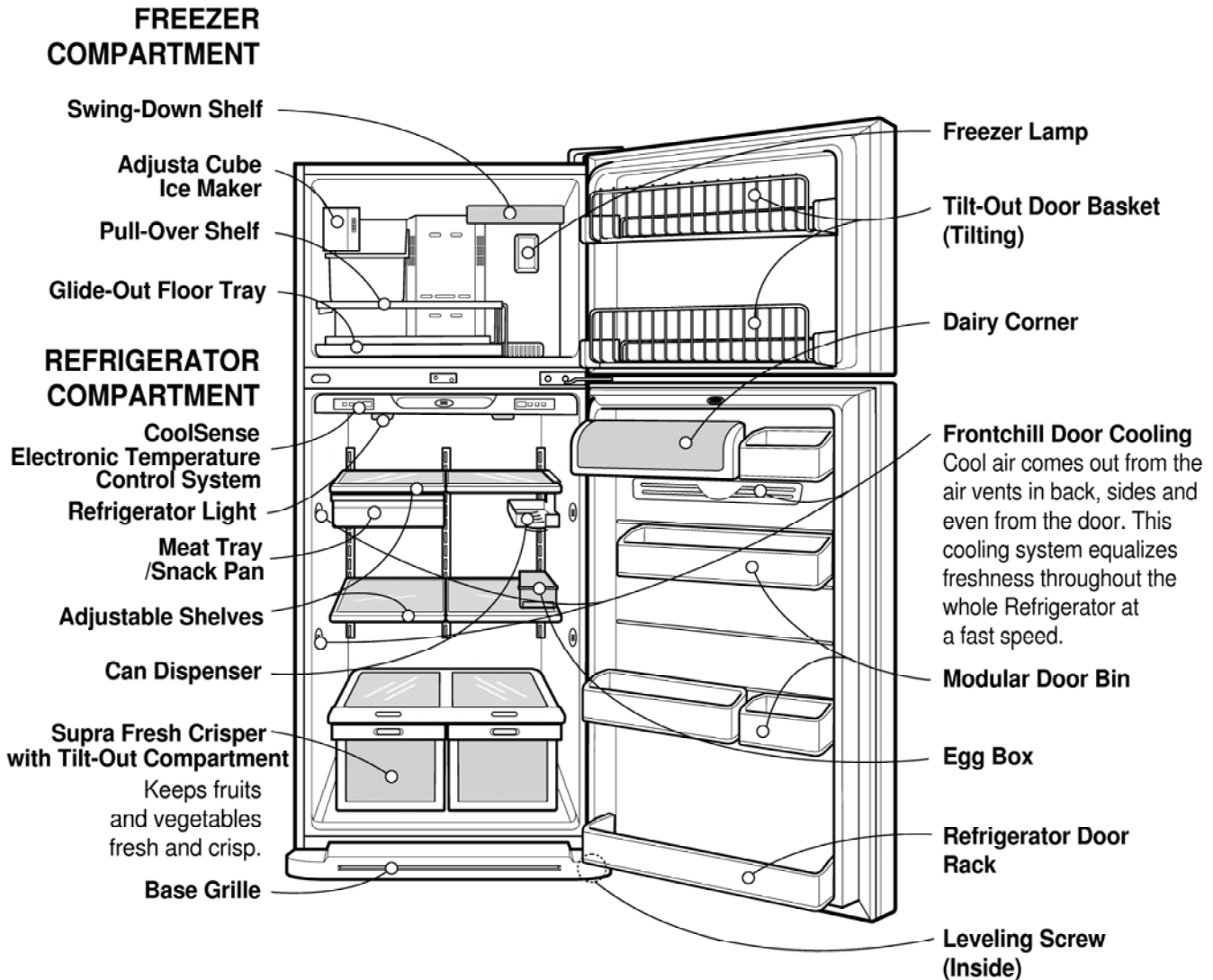

3.DISASSEMBLY

3-1 DOOR

● Freezer Door

1. Remove the hinge cover by pulling it upwards.
2. Loosen hexagonal bolts attaching the upper hinge to the body and lift the freezer door.

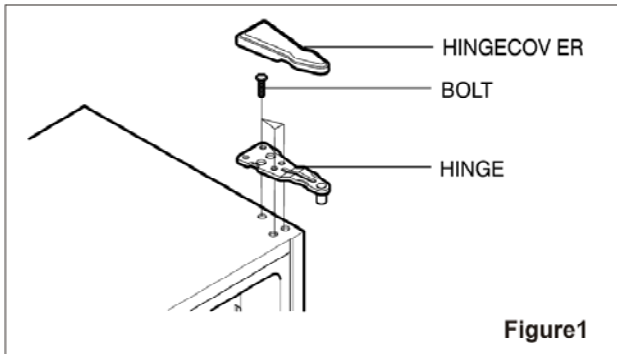

3. Pull out the door gasket to remove from the door foam assembly.

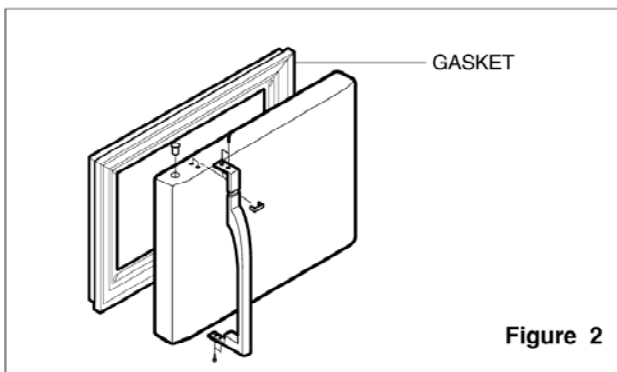

● Refrigerator Door

1. Loosen hexagonal bolts attaching the lower hinge to the body to remove the refrigerator door only.

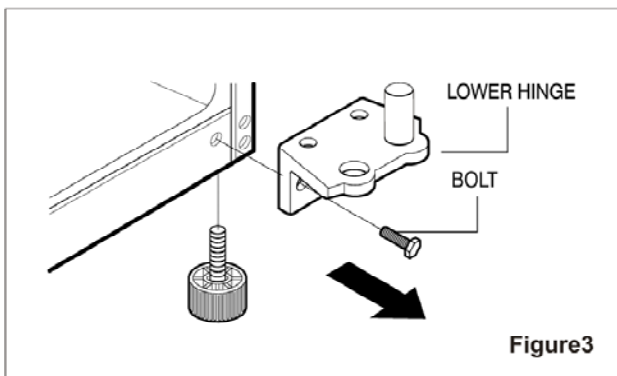

2. Pull out the door gasket to remove from the door foam assembly.

3-2 DOOR SWITCH

1. To remove the door switch, pull it out with a slotted-type driver as shown in (Figure 4).
2. Disconnect the lead wire from the switch.

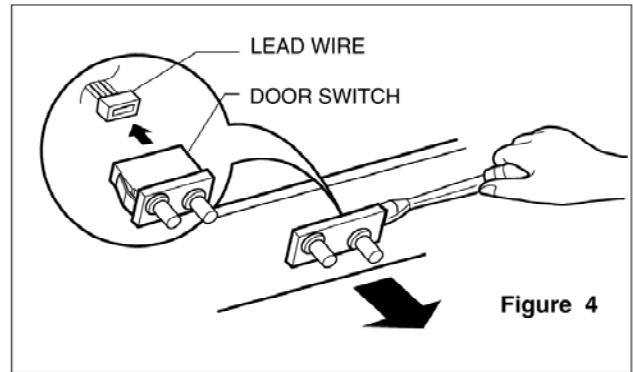

3-3 FAN AND FAN MOTOR

1. Remove the freezer shelf. (If your refrigerator has an icemaker, remove the icemaker first)
2. Remove the grille by pulling it out and by loosening a screw.
3. Remove the Fan Motor assembly by loosening 4 screws and disassemble the shroud.
4. Pull out the fan and separate the Fan Motor and Bracket.

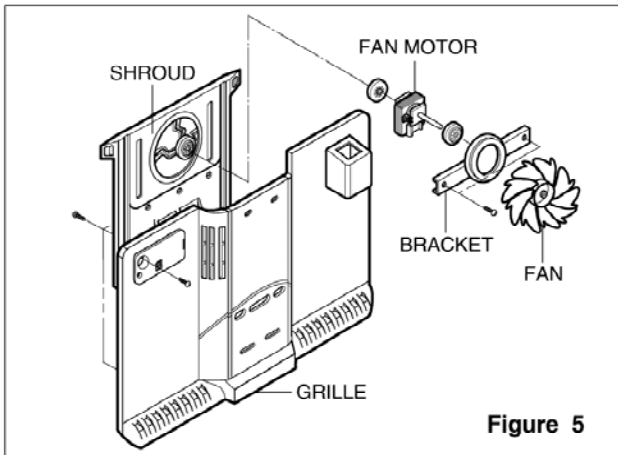

Figure 5

3-4 DEFROST CONTROL ASSEMBLY

Defrost Control assembly consists of Defrost Sensor and FUSE-M.

Defrost sensor functions to defrost automatically. It is attached to metal side of the Evaporator and senses Temperature. At the temperature of 162°F(72°C), it stops the emission of heat from the Heater.

Fuse-M is a safety device for preventing over-heating of the Heater when defrosting.

1. Pull out the grille assembly. (Figure 6)
2. Separate the connector with the Defrost Control assembly and replace the Defrost Control assembly after cutting the Tie Wrap. (Figure 7)

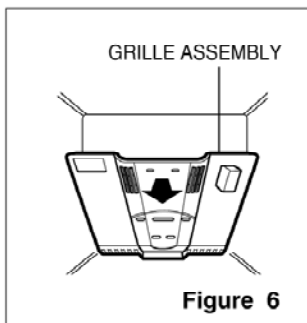

Figure 6

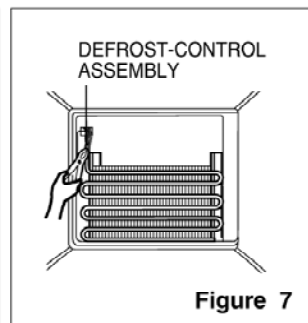

Figure 7

3-5 LAMP

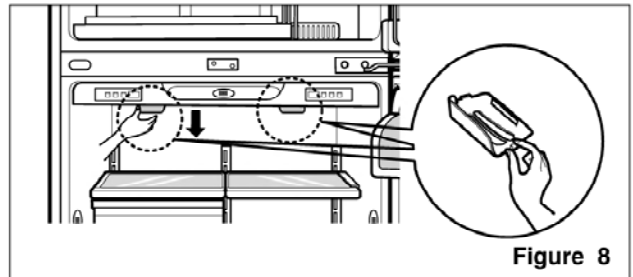

Figure 8

3-5-1 Refrigerator Compartment Lamp

1. Unplug the power cord from the outlet.
2. Remove refrigerator shelves.
3. Release the hooks on both ends of the lamp shield and pull the shield downward to remove it.
4. Turn the lamp counterclockwise.
5. Assemble in reverse order of disassembly. Replacement bulb must be the same specification as the original (Max. 60 W-2EA).

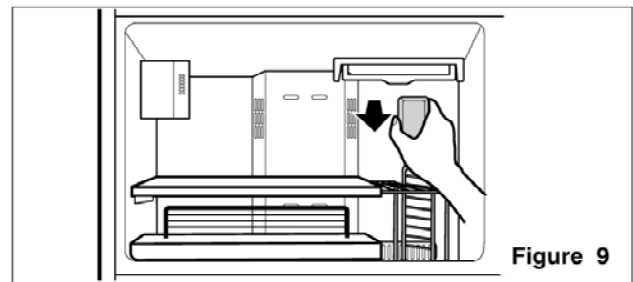

Figure 9

3-5-2 Freezer Compartment Lamp

1. Unplug refrigerator or disconnect power.
2. Reach behind light shield to remove bulb.
3. Replace bulb with a 40-watt appliance bulb.
4. Plug in refrigerator or reconnect power.

3-6 CONTROL BOX-REFRIGERATOR

1. First, remove all shelves in the refrigerator, then remove the Refrigerator Control Box by loosening 2 screws.

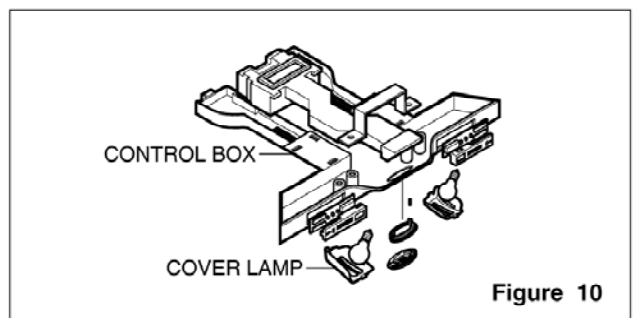

Figure 10

2. Remove the Refrigerator Control Box by pulling it downward.
3. Disconnect the lead wire on the right position and separate the lamp sockets.

4. ADJUSTMENT

4-1 COMPRESSOR

4-1-1 Role

The compressor intakes low temperature and low pressure gas from the evaporator of the refrigerator and compresses this gas to high-temperature and high-pressure gas. It then delivers the gas to the condenser.

4-1-2 Composition

The compressor includes overload protection. The PTC starter and OLP (overload protector) are attached to the outside of the compressor. Since the compressor is manufactured to tolerances of 1 micron and is hermetically sealed in a dust and moisture-free environment, use extreme caution when repairing it.

4-1-3 Note for Usage

- (1) Be careful not to allow over-voltage and over-current.
- (2) If compressor is dropped or handled carelessly, poor operation and noise may result.
- (3) Use proper electric components appropriate to the Particular Compressor in your product.
- (4) Keep Compressor dry.
If Compressor gets wet (in the rain or a damp environment) and rust forms in the pin of the Hermetic Terminal, poor operation and contact may result.
- (5) When replacing the Compressor, be careful that dust, humidity, and soldering flux don't contaminate the inside of the compressor. Dust, humidity, and solder flux contaminate the cylinder and may cause noise or improper operation even cause it to lock up.

4-2 PTC-STARTER

4-2-1 Composition of PTC-Starter

- (1) PTC (Positive Temperature Coefficient) is a no-contact semiconductor starting device which uses ceramic material consisting of BaTiO₃.
- (2) The higher the temperature is, the higher the resistance value. These features are used as a starting device for the Motor.

4-2-2 Role of PTC-Starter

- (1) The PTC is attached to the Sealed Compressor and is used for starting the Motor.
- (2) The compressor is a single-phase induction motor. During the starting operation, the PTC allows current flow to both the start winding and main winding.

4-2-3 PTC-Applied Circuit Diagram

● Starting Method for the Motor

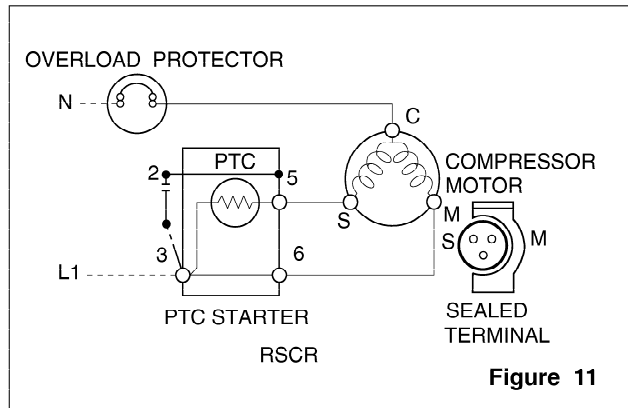

Figure 11

4-2-4 Motor Restarting and PTC Cooling

- (1) It requires approximately 5 minutes for the pressure to equalize before the compressor can start.
- (2) The PTC device generates heat during operation. Therefore, it must be allowed to cool before the compressor can restart.

4-2-5 Relation of PTC-Starter and OLP

- (1) If the compressor attempts to restart before the PTC device is cooled, the PTC device will allow current to flow only to the main winding.
- (2) The OLP will open because of the over current condition. This same process will continue (3 to 5 times) when the compressor attempts to restart until the PTC device has cooled. The correct OLP must be properly attached to prevent damage to the compressor.

4-2-6 Note for Using the PTC-Starter

- (1) Be careful not to allow over-voltage and over-current.
- (2) Do not drop or handle carelessly.
- (3) Keep away from any liquid.
If liquid such as oil or water enters the PTC, PTC materials may fail due to breakdown of their insulating capabilities.
- (4) If the exterior of the PTC is damaged, the resistance value may be altered. This can cause damage to the compressor and result in a no-start or hard-to-start condition.
- (5) Always use the PTC designed for the compressor and make sure it is properly attached to the compressor.

4-3 OLP (OVERLOAD PROTECTOR)

4-3-1 Definition of OLP

- (1) OLP (OVERLOAD PROTECTOR) is attached to the Compressor and protects the Motor by opening the circuit to the Motor if the temperature rises and activating the bimetal spring in the OLP.
- (2) When high current flows to the Compressor motor, the Bimetal works by heating the heater inside the OLP, and the OLP protects the Motor by cutting off the current flowing to the Compressor Motor.

4-3-2 Role of the OLP

- (1) The OLP is attached to the Sealed Compressor used for the Refrigerator. It prevents the Motor Coil from being started in the Compressor.
- (2) For normal operation of the OLP, do not turn the Adjust Screw of the OLP in any way.

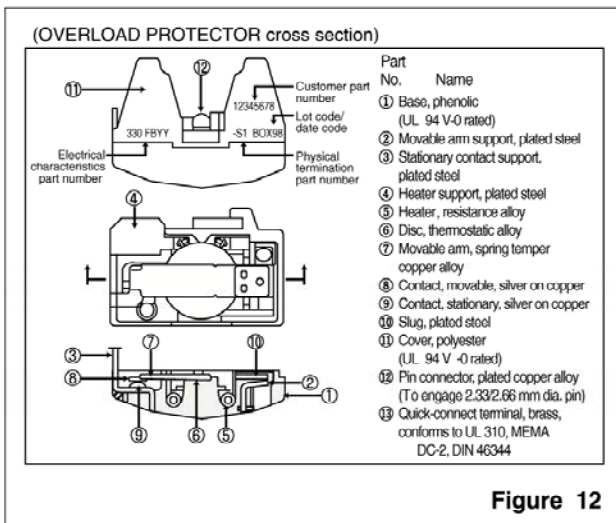

4-4 TO REMOVE THE COVER PTC

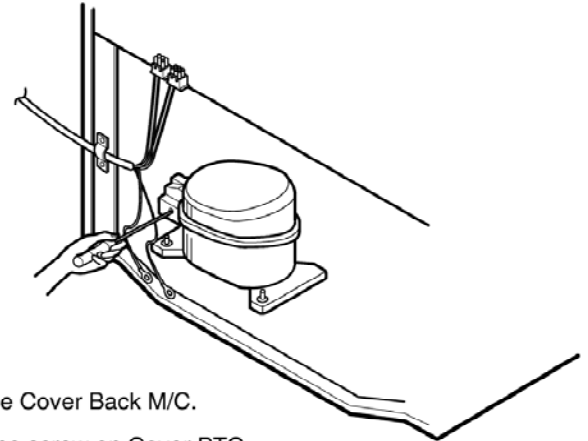

- 1) Remove the Cover Back M/C.
- 2) Remove the screw on Cover PTC.

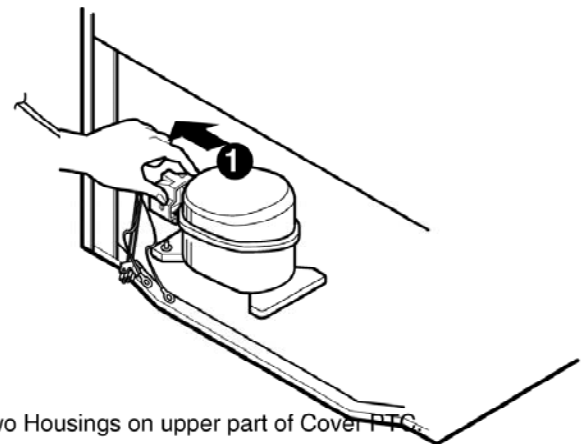

- 3) Remove two Housings on upper part of Cover PTC.
- 4) Take out the cover PTC from upper to lower position like ①.

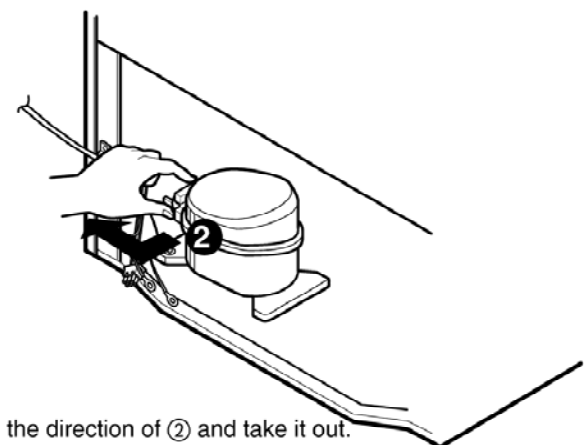

- 5) Turn 45° in the direction of ② and take it out.
- 6) Assembly in reverse order of disassembly.

5.CIRCUITDIAGRAM

Bestmodels

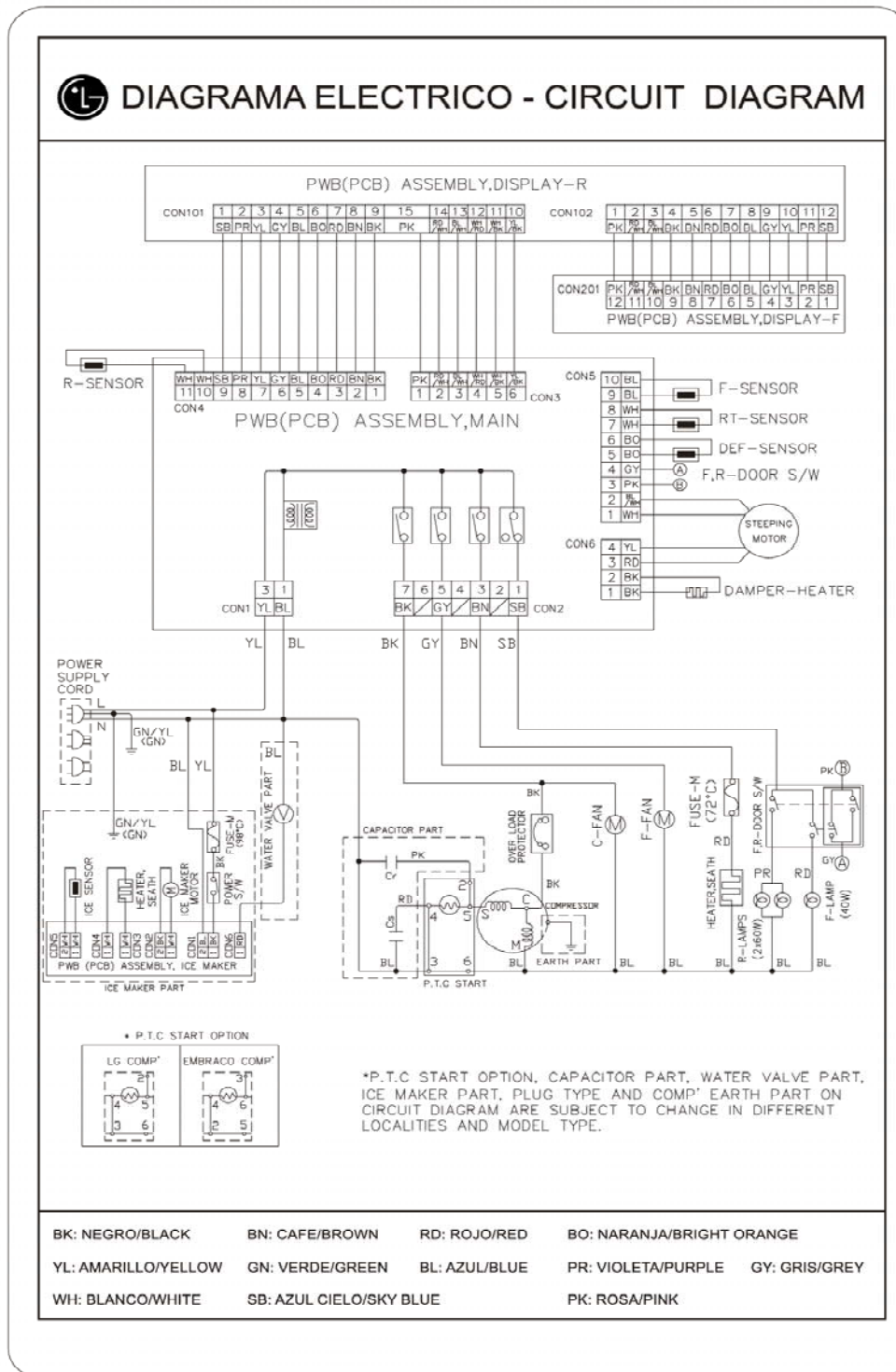

Nota: Los diagramas 3854JK1003A y 3854JK1003B fueron sustituidos por el diagrama 3854JK1005C

Bettermodels



DIAGRAMA ELECTRICO - CIRCUIT DIAGRAM

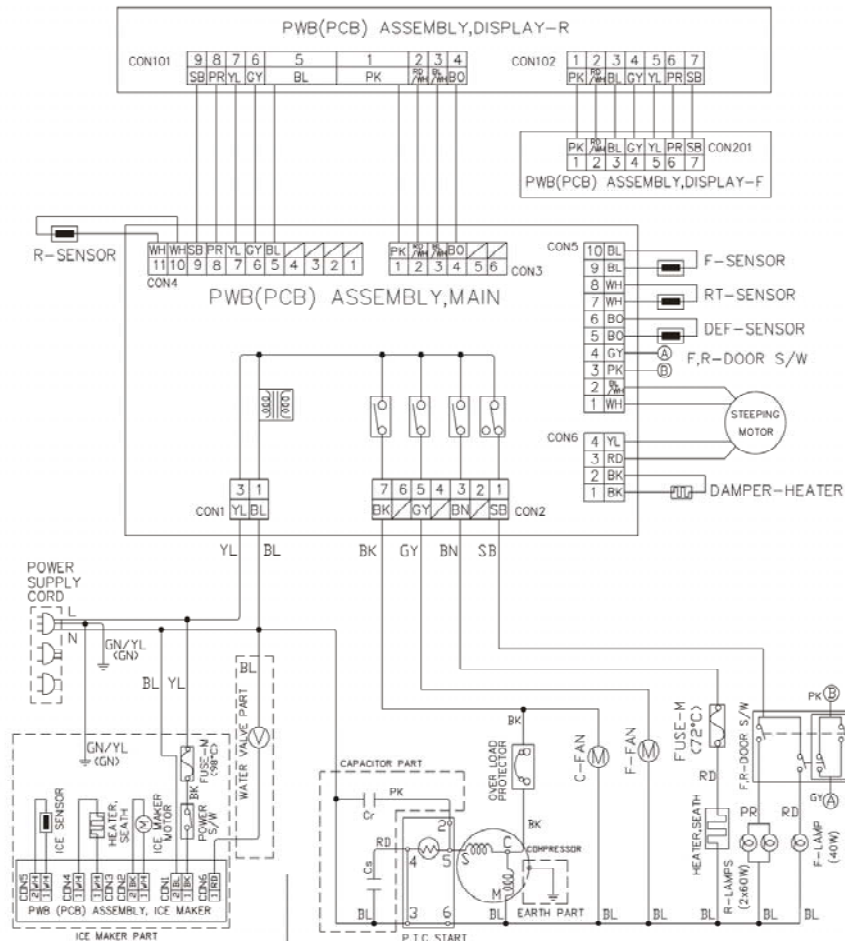

• P.T.C. START OPTION

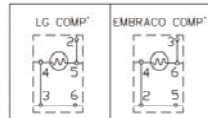

*P.T.C. START OPTION. CAPACITOR PART, WATER VALVE PART, ICE MAKER PART, PLUG TYPE AND COMP' EARTH PART ON CIRCUIT DIAGRAM ARE SUBJECT TO CHANGE IN DIFFERENT LOCALITIES AND MODEL TYPE.

BK: NEGRO/BLACK	BN: CAFE/BROWN	RD: ROJO/RED	BO: NARANJA/BRIGHT ORANGE
YL: AMARILLO/YELLOW	GN: VERDE/GREEN	BL: AZUL/BLUE	PR: VIOLETA/PURPLE
WH: BLANCO/WHITE	SB: AZUL CIELO/SKY BLUE	PK: ROSA/PINK	GY: GRIS/GRAY

Nota: Los diagramas 3854JK1002A y 3854JK1002B fueron sustituidos por el diagrama 3854JK1005B

6. TROUBLESHOOTING

6-1 COMPRESSOR AND ELECTRIC COMPONENTS

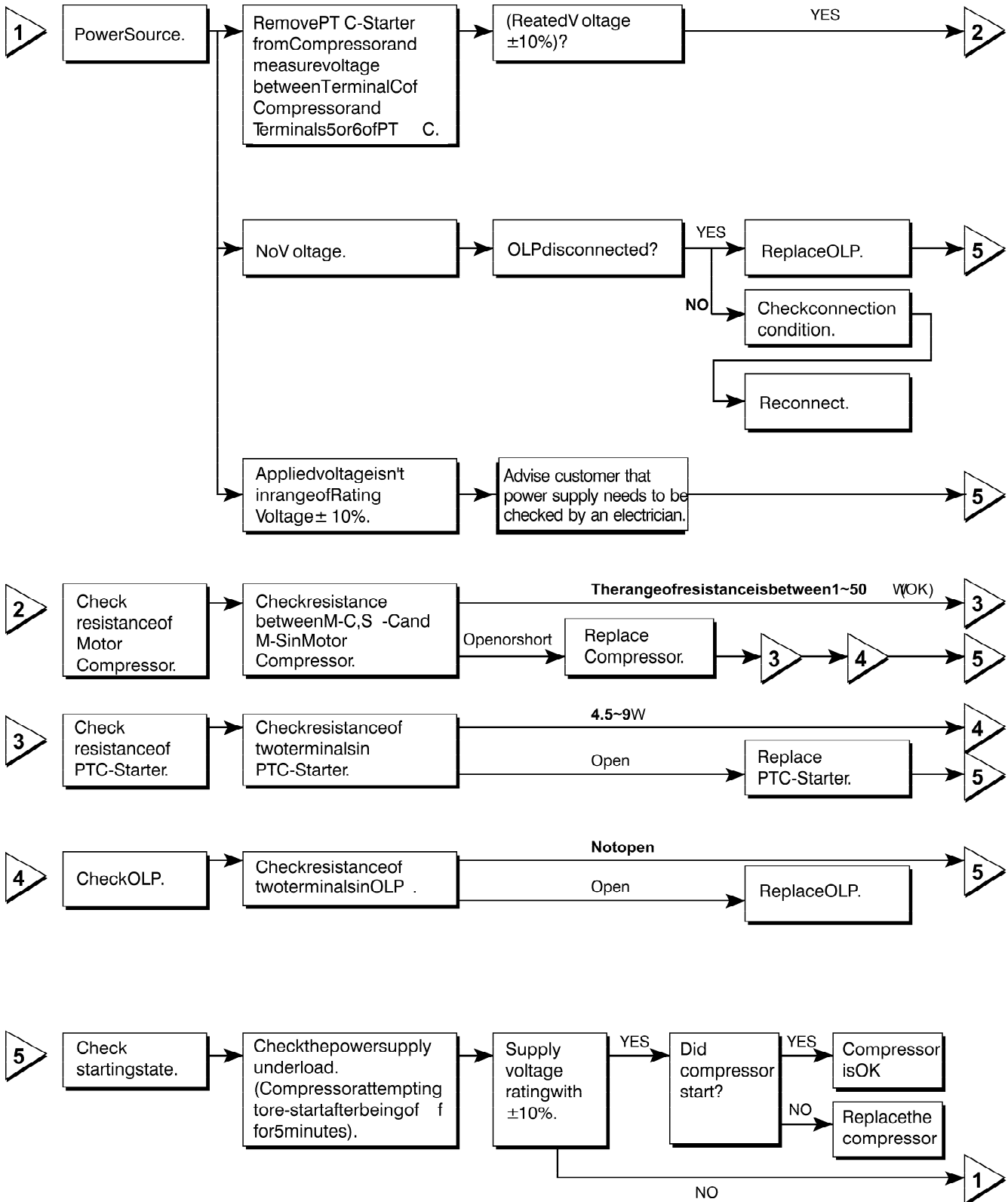

6-2PT CANDOLP

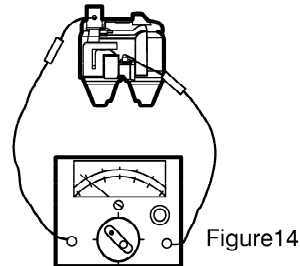
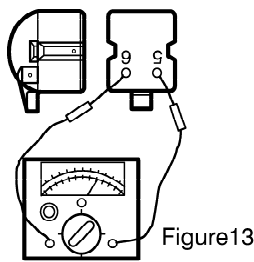
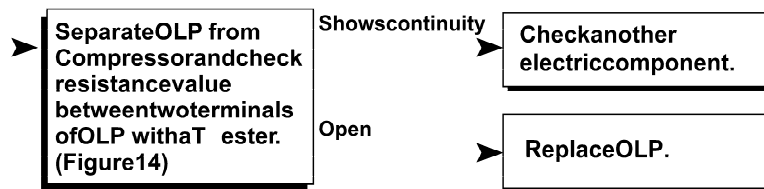
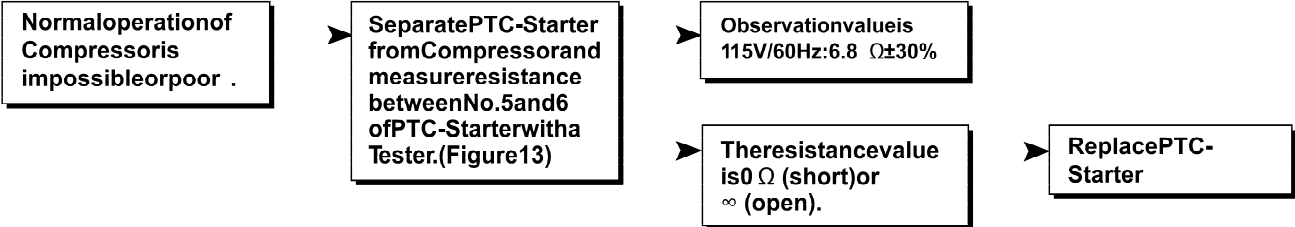

6-3 OTHER ELECTRIC COMPONENTS

▼ Not cooling at all

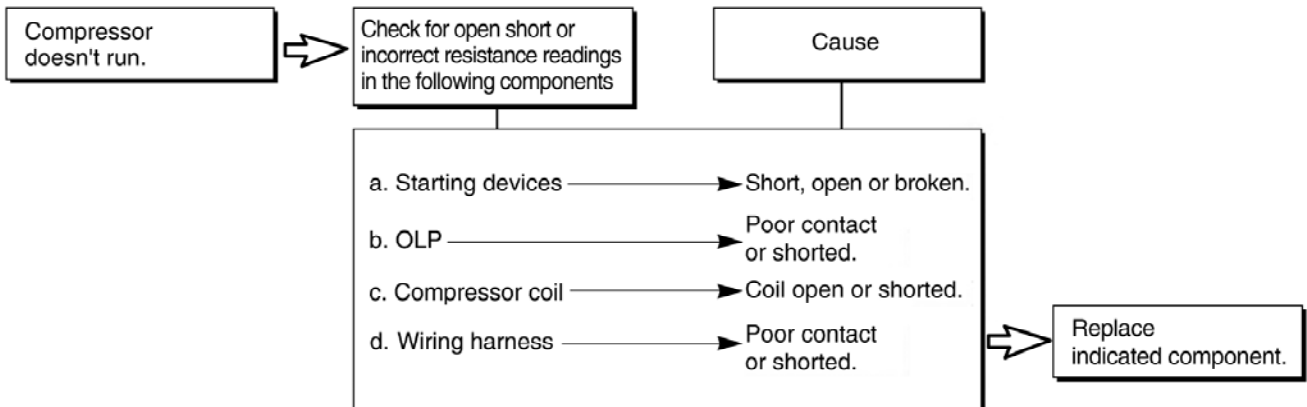

▼ Poor cooling performance

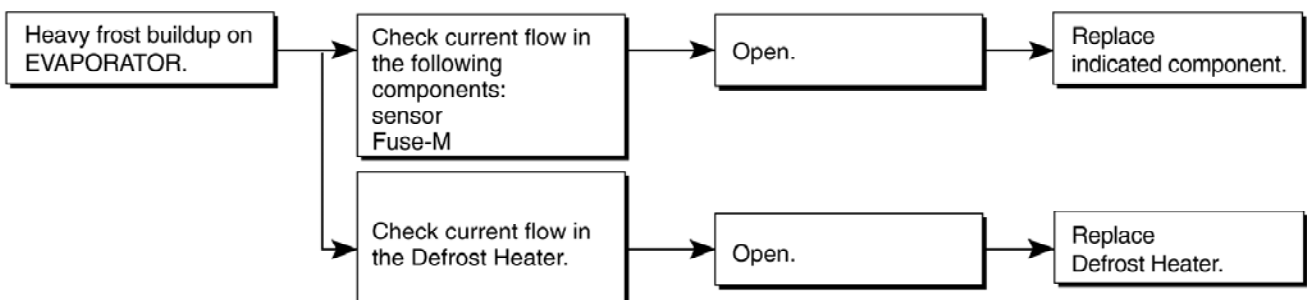
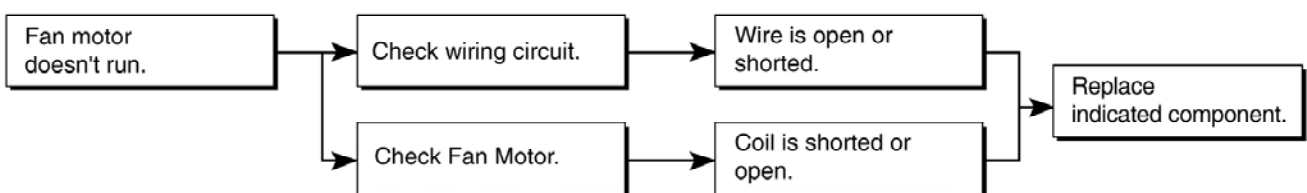
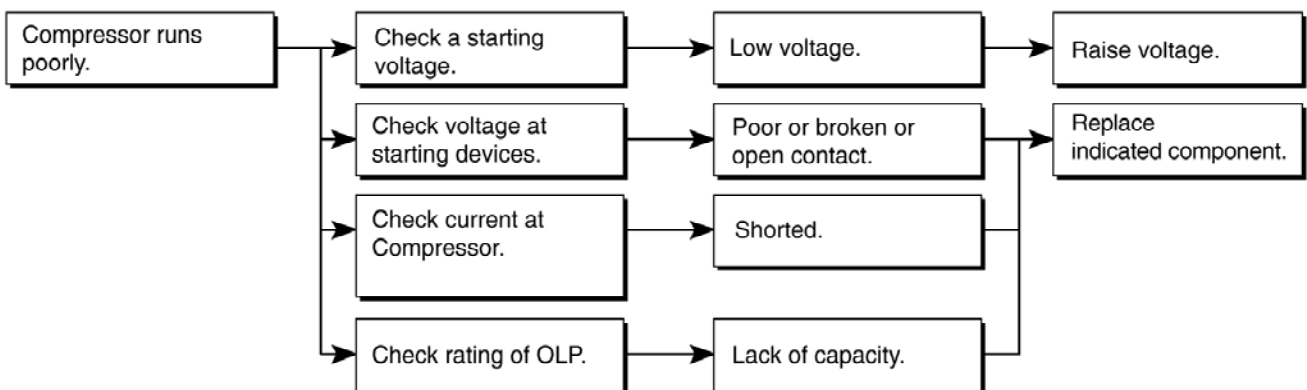

6-4 SERVICE DIAGNOSIS CHART

COMPLAINT	POINTS TO BE CHECKED	REMEDY
No Cooling.	<ul style="list-style-type: none"> • Is the power cord unplugged from the outlet? • Check if the power Switch is set to OFF. • Check if the fuse of the power Switch is shorted. • Measure the voltage of the power outlet. 	<ul style="list-style-type: none"> • Plug into the outlet. • Set the switch to ON. • Replace the fuse. • If the voltage is low, correct the wiring.
Cools poorly.	<ul style="list-style-type: none"> • Check if the unit is placed too close to the wall. • Check if the unit is placed too close to the stove, gas cooker, or in direct sunlight. • Is the ambient temperature too high or the room door closed? • Check if food put in the refrigerator is hot. • Did you open the door of the unit too often or check if the door is sealed properly? • Check if the Control is set to Warm position. 	<ul style="list-style-type: none"> • Place the unit about 10 cm from the wall. • Place the unit away from these heat sources. • Lower the ambient temperature. • Put in foods after they have cooled down. • Don't open the door too often and close it firmly. • Set the control to Recommended-position.
Foods in the Refrigerator are frozen.	<ul style="list-style-type: none"> • Is food placed in the cooling air outlet? • Check if the control is set to colder-position. • Is the ambient temperature below 41°F(5°C)? 	<ul style="list-style-type: none"> • Place foods in the high-temperature section. (front part) • Set the control to Recommended-position. • Set the control to Warm-position.
Condensation or ice forms inside the unit.	<ul style="list-style-type: none"> • Is liquid food sealed? • Check if food put in the refrigerator is hot. • Did you open the door of the unit too often or check if the door is sealed properly? 	<ul style="list-style-type: none"> • Seal liquid foods with wrap. • Put in foods after they have cooled down. • Don't open the door too often and close it firmly.
Condensation forms in the Exterior Case.	<ul style="list-style-type: none"> • Check if the ambient temperature and humidity of the surrounding air are high. • Is there a gap in the door gasket? 	<ul style="list-style-type: none"> • Wipe moisture with a dry cloth. It will disappear in low temperature and humidity. • Fill up the gap.
There is abnormal noise.	<ul style="list-style-type: none"> • Is the unit positioned in a firm and even place? • Are any unnecessary objects placed in the back side of the unit? • Check if the Drip Tray is not firmly fixed. • Check if the cover of the compressor enclosure in the lower front side is taken out. 	<ul style="list-style-type: none"> • Adjust the Leveling Screw, and position in a firm place. • Remove the objects. • Fix the Drip Tray firmly in the original position. • Place the cover in its original position.
Door does not close well.	<ul style="list-style-type: none"> • Check if the door gasket is dirty with an item like juice. • Is the refrigerator level? • Is there too much food in the refrigerator? 	<ul style="list-style-type: none"> • Clean the door gasket. • Position in the firm place and level the Leveling Screw. • Make sure food stored in shelves does not prevent the door from closing.
Ice and foods smell unpleasant	<ul style="list-style-type: none"> • Check if the inside of the unit is dirty. • Are foods with a strong odor unwrapped? • The unit smells of plastic. 	<ul style="list-style-type: none"> • Clean the inside of the unit. • Wrap foods that have a strong odor. • New products smell of plastic, but this will go away after 1-2 weeks.

● Other possible problems:

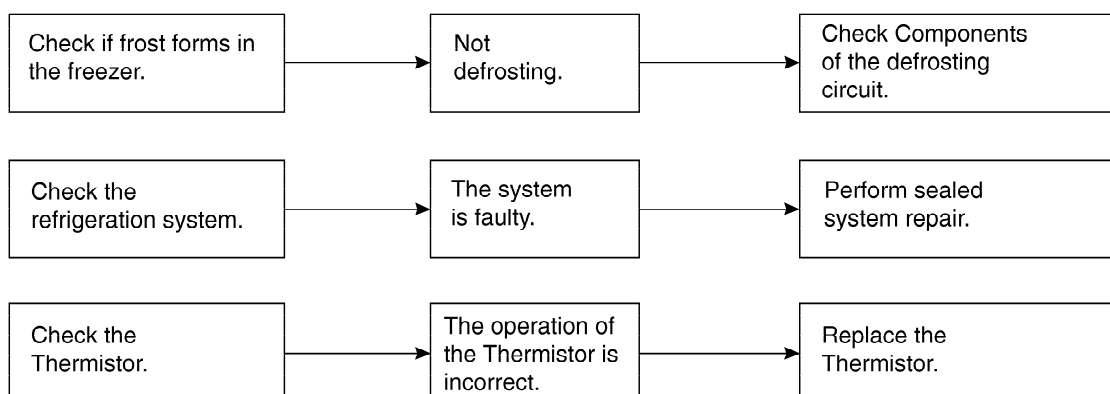

6-5 REFRIGERATING CYCLE

▼ Troubleshooting Chart

CAUSE		STATE OF THE UNIT	STATE OF THE EVAPORATOR	TEMPERATURE OF THE COMPRESSOR	REMARKS
LEAKAGE	PARTIAL LEAKAGE	Freezer compartment and Refrigerator don't cool normally.	Low flowing sound of Refrigerant is heard and frost forms in inlet only.	A little higher than ambient temperature.	<ul style="list-style-type: none"> Refrigerant level is low due to a leak. Normal cooling is possible by restoring the normal amount of refrigerant and repairing the leak.
	COMPLETE LEAKAGE	Freezer compartment and Refrigerator don't cool normally.	Flowing sound of refrigerant is not heard and frost isn't formed.	Equal to ambient temperature.	<ul style="list-style-type: none"> No discharging of Refrigerant. Normal cooling is possible by restoring the normal amount of refrigerant and repairing the leak.
RESTRICTED BY DUST	PARTIAL RESTRICTION	Freezer compartment and Refrigerator don't cool normally.	Flowing sound of refrigerant is heard and frost forms in inlet only.	A little higher than ambient temperature.	<ul style="list-style-type: none"> Normal discharging of the refrigerant. The capillary tube is faulty.
	WHOLE RESTRICTION	Freezer compartment and Refrigerator don't cool.	Flowing sound of refrigerant is not heard and frost isn't formed.	Equal to ambient temperature.	<ul style="list-style-type: none"> Normal discharging of the Refrigerant.
MOISTURE RESTRICTION		Cooling operation stops periodically.	Flowing sound of refrigerant is not heard and frost melts.	Lower than ambient temperature.	<ul style="list-style-type: none"> Cooling operation restarts when heating the inlet of the capillary tube.
DEFECTIVE COMPRESSION	COMP-RESSION	Freezer and Refrigerator don't cool.	Low flowing sound of refrigerant is heard and frost forms in inlet only.	A little higher ambient temperature.	<ul style="list-style-type: none"> Low pressure at high side of compressor due to low refrigerant level.
	NO COMP-RESSION	No compressing operation.	Flowing sound of refrigerant is not heard and there is no frost.	Equal to ambient temperature.	<ul style="list-style-type: none"> No pressure in the high pressure part of the compressor.

▼ Leakage Detection

- Observe the discharging point of the refrigerant, which may be in the oil discharging part of the compressor and in a hole in the evaporator.

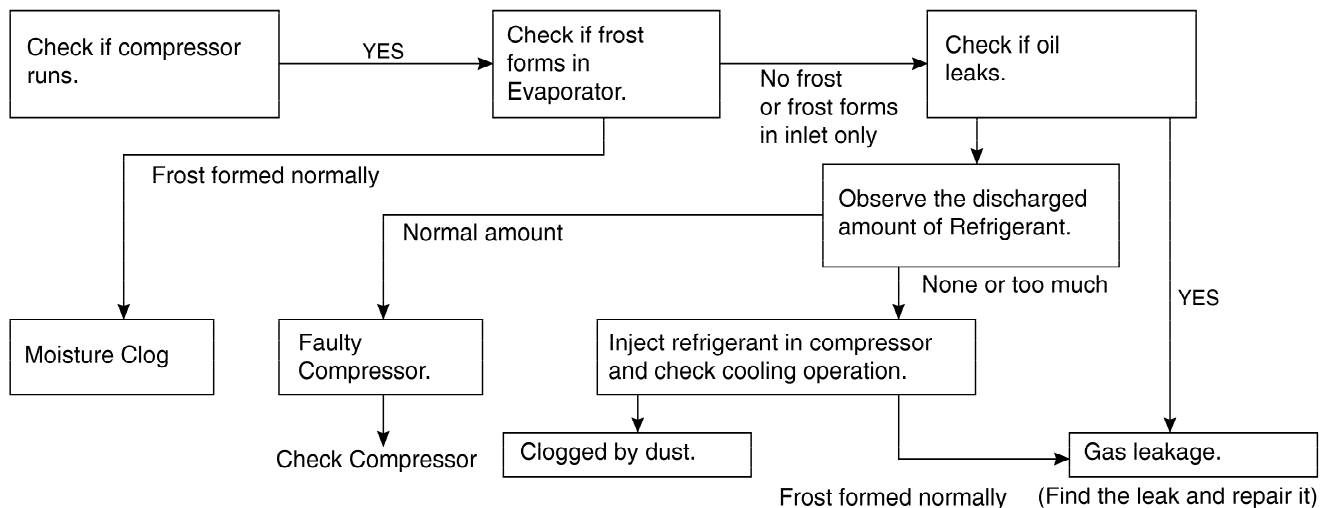

▼ General Control of Refrigerating Cycle

NO.	ITEMS	UNIT	STANDARDS	PURPOSES	REMARKS	
1	Pipe and piping system opening time	Min.	Pipe: within 1 hour. Comp: within 10 minutes. Drier: within 20 minutes.	To protect moisture penetration.	The opening time should be reduced to a half of the standards during rain and rainy seasons (the penetration of water into the pipe is dangerous).	
2	Welding	Nitrogen pressure	Weld under Nitrogen atmosphere. (N ₂ pressure: 0.1~0.2 kg/cm ²)	To protect oxide scale formation.	- Refer to repair note in each part. - R-134a refrigerant is more susceptible to leaks than R-12 and requires more care during welding. - Do not apply force to pipes before and after welding to protect pipe from cracking.	
3	N ₂ sealed parts	Confirm N ₂ leak	Confirm the sound of pressure relief when removing the rubber cap. Sound: usable No sound: not usable	To protect moisture penetration.	- In case of evaporator parts, if it doesn't make sound when removing rubber cap, blow dry air or N ₂ gas for more than 1 min. and then use the parts.	
4	Refrigeration Cycle	Evacuation time	Min.	More than 40 minutes	To remove moisture.	
		Vacuum degree	Torr	Below 0.03 (ref)		Note: Only applicable to the model equipped with reverse flow protect plate.
		Vacuum	EA	High and low pressure sides are evacuated at the same time for models above 200 l.		Vacuum efficiency can be improved by operating compressor during evacuation.
		Vacuum piping	EA	Use R-134a manifold exclusively.	To protect mixing of mineral and ester oils.	The rubber pipes for R-12 refrigerant will be melted when they are used for R-134a refrigerant (causes of leak.)
		Pipe coupler	EA	Use R-134a manifold exclusively.	To protect R-12 refrigerant mixing.	
		Outlet (Socket)		R-134a manifold exclusively.	To protect R-12 refrigerant mixing.	
		Plug		R-134a manifold exclusively.	To protect R-12 refrigerant mixing.	
5	Refrigerant weighing	EA	Use R-134a exclusively. Weighing allowance: ±5g Note: Winter: -5g Summer: +5g	Do not mix with R-12 refrigerant.	- Do not weigh the refrigerant at too hot or too cold an area. (77°F [25°C] is adequate.) - Make Copper charging canister (Device filling refrigerant) Socket: 2SV Plug: 2PV R-134a Note: Do not burn O-ring (bushing) during welding.	
6	Drier replacement		- Use R-134a exclusively for R-134a refrigerator. - Replace drier whenever repairing refrigerator cycle piping.	To remove the moisture from pipe inside.		
7	Leak check		- Do not use soapy water for check. It may be sucked into the pipe by a vacuum.	Defect in refrigerant leak area.	- Check for an oil leak at the refrigerant leak area. Use an electronic leak detector if an oil leak is not found. - The electronic leak detector is very sensitive to halogen gas in the air. It also can detect R-141b in urethane. Practice many times before using this type of detector to avoid false readings.	

7. OPERATION PRINCIPLE AND REPAIR METHOD OF ICE MAKER

7-1 OPERATION PRINCIPLE

7-1-1 Operation Principle of Ice Maker

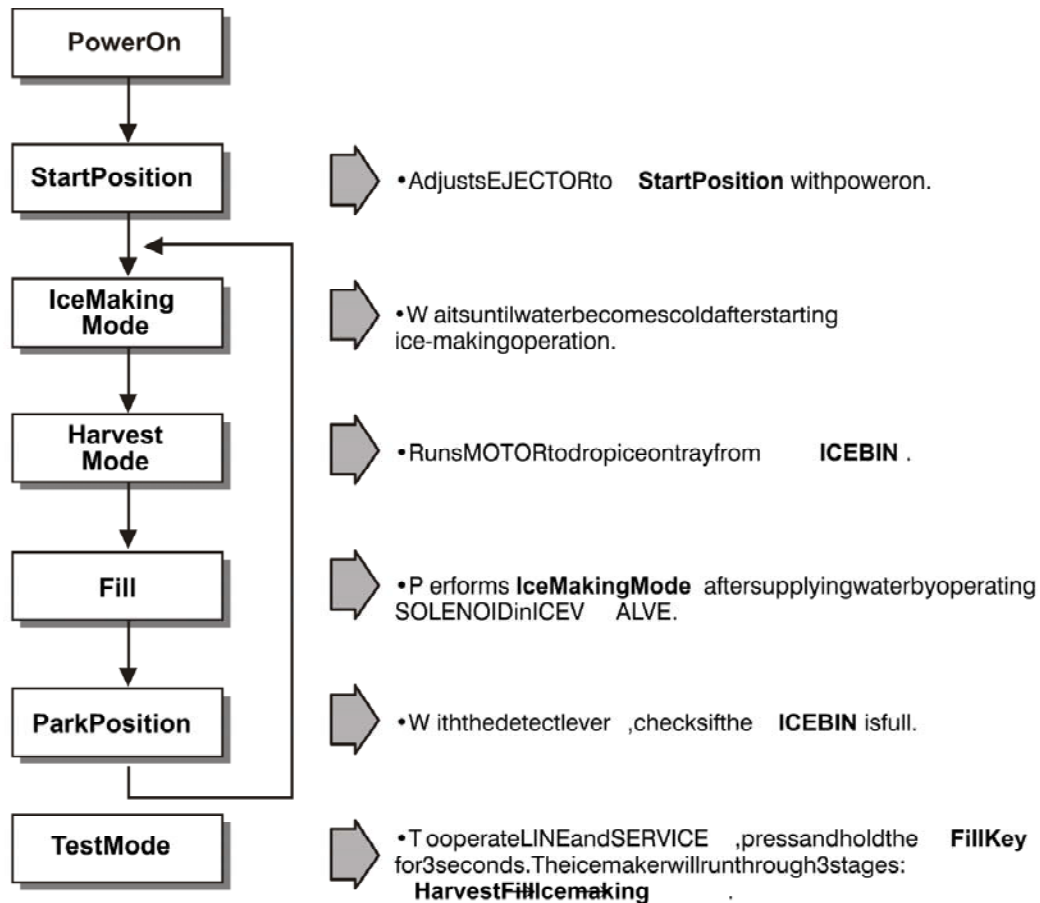

1. Turning the ice making stop switch of (O) stops the ice making function.
2. Setting the ice maker switch to OFF and then turning it back on will reset the ice maker control.

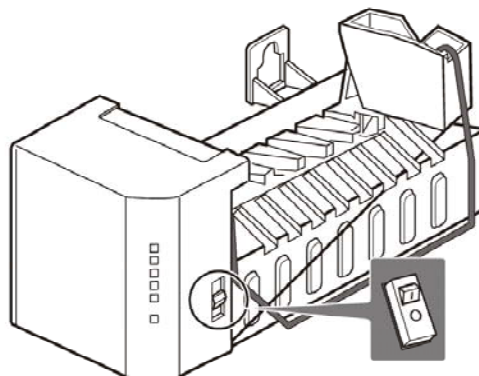

7-2 CONTROL METHOD ACCORDING TO FUNCTIONS

7-2-1 Start Position

1. After POWER OFF or Power Cut, check EJECT OR's position with MICOM initialization to restart.
2. Control Method to check if it's in place:
 - (1) EJECT OR is in place,
 - The ejector must be in the park position before a new cycle can be initiated.
 - (2) EJECT OR is not in place:
 - A. If there is no ice formed in the icemaker, it should take approximately 2 minutes for the ejector blades to cycle through the harvest mode and return to the park position.
 - B. If there is ice formed in the icemaker, it can take up to 18 minutes for the ejector blades to cycle through the harvest mode and return to the park position.

7-2-2 Ice Making Mode

1. The Ice Making Mode starts once the ejector is in the park position and the icemaker mold is filled with water.
2. The Ice Making Mode is terminated when the icemaker sensor reaches 19 °F (-7°C). This may take between 1 and 4 hours.

7-2-3 Harvest Mode

1. The Harvest mode is initiated when the temperature is satisfied with the shut-off arm in the down position.
2. Once the Harvest mode is initiated, the heater is operated for 30 seconds.
3. After 30 seconds, the ejector blades are operated. (Pin 10 of micom from the hall sensor will read 5V.)
4. Once the ejector blades have reached the park position and the hall sensor is reading 0V, water fill will be initiated.



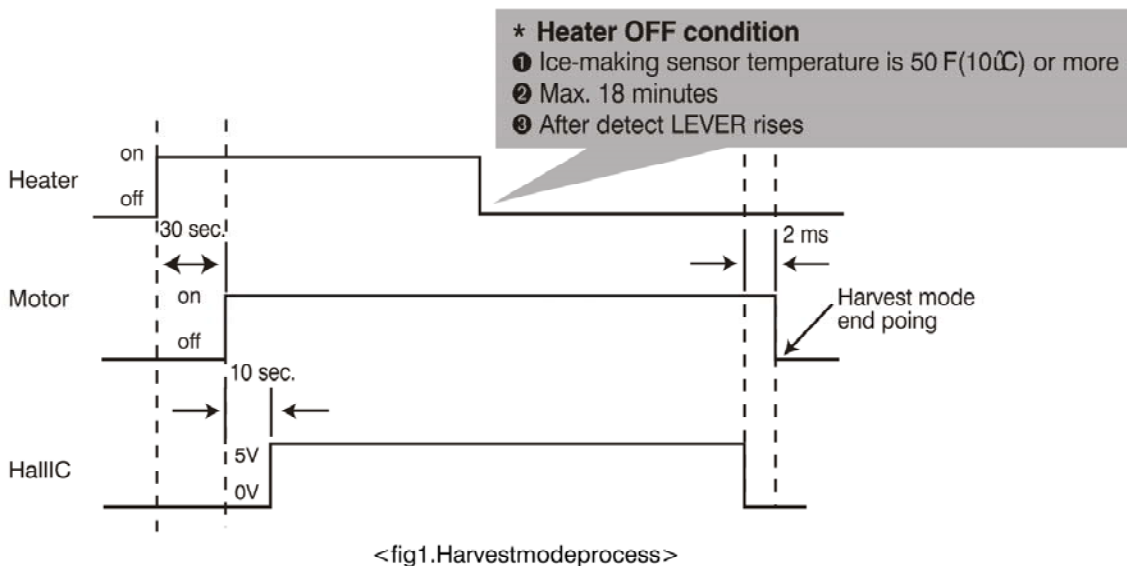

NOTE: If no movement is detected from the shut-off arm (detect lever), a Harvest mode will be attempted every 2 hours.



7-2-4 Fill/Park Position

1. Once an normal harvest mode has been completed, the water solenoid will be activated.
2. The amount of water is adjusted by pressing the water supply control switch. This changes the time allowed for fill as illustrated in the chart.

Water supply amount T ABLE

STAGE	TIMET OS UPPLY	INDICATIONS	REMARKS
1	6sec.		The water amount will vary depending on the water control switch setting, as well as the water pressure of the connected waterline.
2	7sec.		
3	8sec.		
4	9sec.		
5	10sec.		



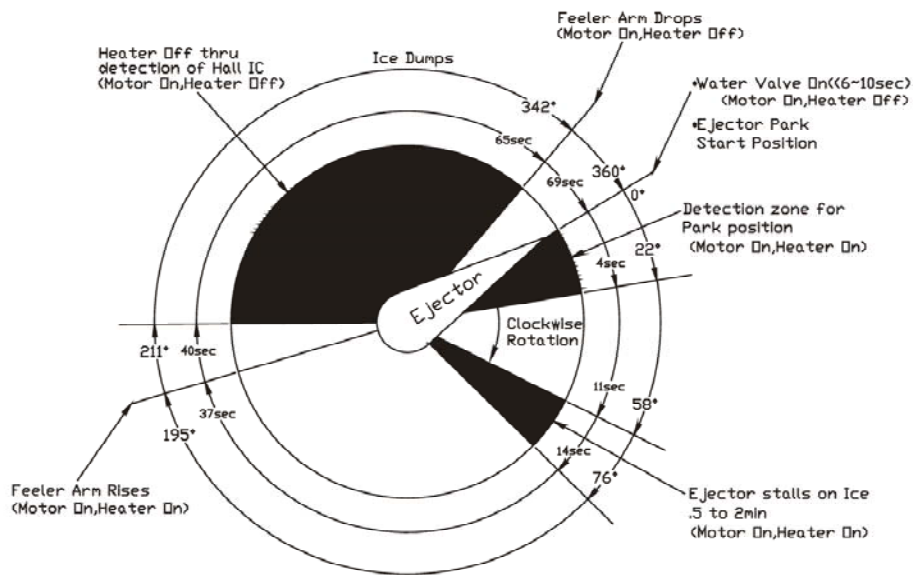

NOTE: Below is an example used by another vendor as an explanation of what is taking place.



7-2-5 Function TEST



1. This is a compulsory operation for TEST, SVC, cleaning, etc. It is operated by pressing the water supply control KEY for 3 seconds.
2. It operates in the Icemaking mode, but not in the Ice-Removing mode or water supply process. (If there is an ERROR, it can only be checked in the TEST mode.)
3. If the water supply control KEY is pressed for 3 seconds in the Ice-Making mode (no matter what condition the Ice-Making tray is in) the Ice-Removing operation starts immediately. Water is not yet frozen, so water is poured instead of ice. If the control doesn't operate normally in the TEST mode, check and repair as needed.
4. After water is supplied, the normal CYCLE is followed: **ice making** → **Harvest** → **Fill** → **Park position**.
5. When Stage 5 is completed in the TEST mode, minimize MICOM in 5 seconds, the time needed to supply water resets to the previous status in the TEST mode.

Diagnosis TABLE

STAGE	ITEMS	INDICATOR	REMARKS
1	HEATER		Five seconds after heater starts, heater will go off if temperature recorded by sensor is 50°F(10°C) or lever is in up position.
2	MOTOR		Five seconds after heater starts, you can confirm that motor is moving.
3	HALL IC (detection of position) I		You can confirm Hall IC detection of position.
4	VALVE		Two seconds after detection of initial position, you can confirm that valve is on.
5	HALL IC (detection of full-filled Ice) II		You can check whether hall is sensing Full ice condition. (If there is a full-filled error, the fifth LED is not on.)
6	reset	Mark previous status on TEST mode	Five seconds after fifth stage is completed, the Icemaker reset at initial status.

7-3 DEFECT DIAGNOSIS FUNCTION

7-3-1 ERROR CODES shown on Ice Maker water supply control panel

NO	DIVISION	INDICATOR	CONTENTS	REMARKS
1	Normal	Mark time to supply	None	Display switch operates properly
2	Ice-Making Sensor malfunction		Open or short-circuited wire	Make sure that the wire on each sensor is connected.
3	Ice Maker Kit malfunction		When ejector blades don't reach park position over 18 minutes since Harvest Mode starts.	Defects of HALL IC/MOTOR/ HEATER/RELAY

ERROR indicators in table can be checked only in TEST mode.

8. DESCRIPTION OF FUNCTION & CIRCUIT OF MICOM

8-1 FUNCTION

8-1-1 Function

- When the appliance is plugged in, it is set to "37 °F" for the Refrigerator and "0 °F" for the Freezer (set to "4" for Refrigerator and "4" for Freezer).
You can adjust the Refrigerator and the Freezer control temperature by pressing the COLDER button or the COLD button.
- When the power is initially applied or restored after a power failure, it is automatically reset to "37 °F" and "0 °F" (set to "4" and "4").

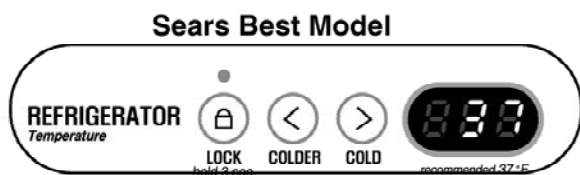

Control range : 32°F ~ 47°F
0°C ~ 8°C

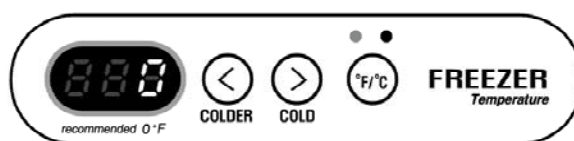

Control range : -6°F ~ 8°F
-21°C ~ -13°C

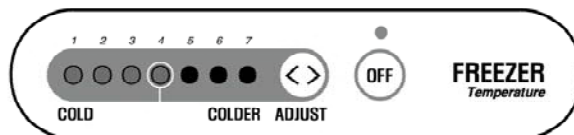
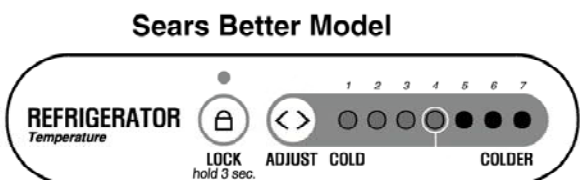

8-1-2 How to Change the Temperature Mode to °F / °C

- The setting temperature mode can be changed to °F / °C by pressing the " °F / °C " button.
- The initial setting is on °F. When the mode is changed the LED lights come on.

8-1-3 Key Lock

- The key pads can be locked by pressing and holding the KEY LOCK button for 3 seconds.
- The lock light will be displayed and the key pads will be inoperable.
- Pressing and holding the KEY LOCK button for 3 seconds will reactivate the key pads.

8-1-4 OFF Function

- To turn off the Best model, press and hold the °F/°C button for 3 seconds. To turn off the Better model, press and hold the OFF key for 3 seconds.
- In the Off mode, the Best model will display OFF in the control panel. The OFF light will be displayed on the Better model.
- To cancel the OFF function, press the same keys and hold for 3 seconds.

8-1-5 Alarm for Open Door

1. This feature sounds a buzzer when the freezer or refrigerator door is not closed within 1 minute after it is opened.
2. One minute after the door is opened, the buzzer sounds three times each for 0.5 seconds. These tones repeat every 30 seconds.
3. The alarm is cancelled when the freezer or the refrigerator is closed while the buzzer sounds.

0

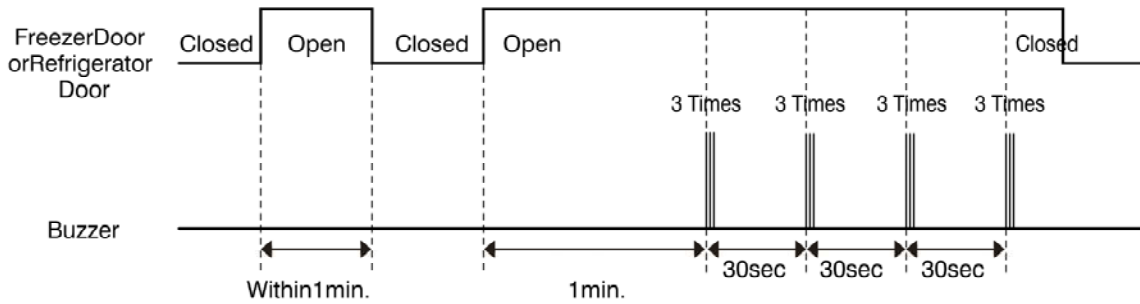

8-1-6 Buzzer Sound

When the button on the front Display is pushed, a "Ding~" sound is produced.

8-1-7 Defrost Cycle

1. A defrost cycle will be initiated after 4 hours of accumulated compressor runtime after the initial power up or power failure.
2. After the initial defrost, the defrost cycle is initiated after 7 hours of accumulated compressor runtime.
3. The defrost cycle will be terminated once the defrost sensor reaches 50 °F (10°C).

8-1-8 Electrical Parts Operates in Orders

Electrical parts such as COMP, defrost heater, freezer FAN, etc. operate in the following order to prevent noise and parts damage. Several parts are started at the same time at initial power on and are returned to together when TEST is completed.

OPERATING		ORDERS				
Initial power on	Temperature of Defrost Sensor is 13°F (45°C) or more (when unit is newly purchased or when moved)	POWER ON	in 1/2 second →	COMP ON	in 1/2 second →	Freezer FAN ON
	Temperature of defrost sensor is lower than 113°F (45°C) (when power cuts, SERVICE)	POWER ON	in 1/2 second →	Defrost heater ON	in 10 second →	Defrost heater OFF
			in 1/2 second →	COMP ON	in 1/2 second →	Freezer FAN ON
Reset to normal operation from TEST MODE		Total load OFF	in 7 minute →	COMP ON	in 1/2 second →	Freezer FAN ON

8-1-9 Defect Diagnosis Function

1. Error codes will be displayed when defect occurs which can affect product performance.
2. When a defect occurs, the buttons will not operate; but the tones such as "ding" will sound.
3. When error code is resolved, the refrigerator will restart normally (Micom will be reset).
4. The error code shows on the refrigerator DISPLAY as temperature LED, and the other LED turns off.



-Show ERROR CODE on Refrigerator Temperature Panel and Freezer Temperature panel.

NO	ITEM	ERROR CODE		CONTENTS	REMARKS
		REF. TEMP. PANEL	FRZ. TEMP. PANEL		
1	Freezer sensor malfunctions	Er	F5	Open or short-circuited wire	*Inspect connecting wires on each sensor
2	Refrigerator sensor malfunctions	Er	r5	Open or short-circuited wire	
3	Defrost sensor malfunctions	Er	d5	Open or short-circuited wire	
4	Room Temperature sensor malfunctions	On LED CHECK mode ERROR CODE sign		Open or short-circuited wire	
5	Defrosting malfunctions	Er	dH	2 hours after defrosting starts, the sensor is not above 50°F(10°C)	Temperature fuse open, Heater open, Drain is clogged, Heater starts but relay malfunctions.

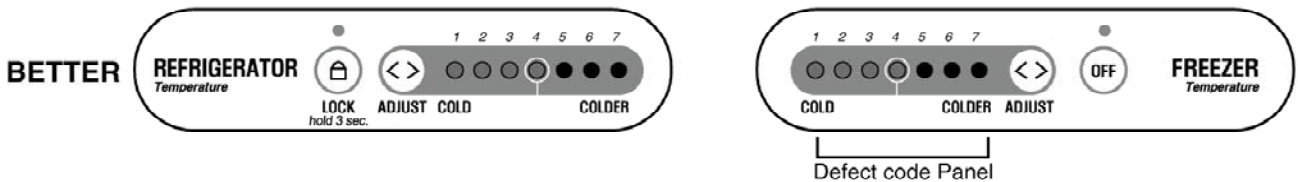

-Show ERROR CODE on Freezer Temperature panel.

○ :ON ● :OFF

NO	ITEM	DEFECT SIGNS							CONTENTS	REMARKS
		F1	F2	F3	F4	F5	F6	F7		
1	Freezer sensor malfunctions	●	○	○	○	○	○	○	Open or short-circuited wire	*Inspect connecting wires on each sensor
2	Refrigerator sensor malfunctions	○	●	○	○	○	○	○	Open or short-circuited wire	
3	Defrost sensor malfunctions	○	○	●	○	○	○	○	Open or short-circuited wire	
4	Room Temperature sensor malfunctions	On LED CHECK mode							Open or short-circuited wire	
5	Defrosting malfunctions	●	●	●	●	○	○	○	2 hours after defrosting starts, the sensor is not above 50°F(10°C)	Temperature fuse open, Heater open, Drain is clogged, Heater starts but relay malfunctions.

8-1-10 TEST Mode

1. The Test mode allows checking the PCB and the function of the product as well as finding out the Defective part in case of an error.
2. The test button is on the main PCB of the refrigerator (Test S/W). The test mode will be cleared in 2 hours regardless of the type of test mode.
3. While in the test mode, the function control button will not operate, though the recognition tone (beep~) sounds.
4. After exiting the test mode, be sure to reset by unplugging and then plugging in the appliance.
5. If an error (such as a sensor failure) is detected while in the test mode, the test mode is cleared and the error code is displayed.
6. While an error code is displayed, the test mode will not be activated even if the test button is pushed.

MODE	MANIPULATION	CONTENTS	REMARKS
TEST1	Push the test button once.	<ol style="list-style-type: none">1. Continuous operation of the COMP2. Continuous operation of the freezer fan3. STEPPING DAMPER OPEN4. Defrosting Heater OFF5. Every DISPLAY LED ON	
TEST2	Push the test button once while in TEST MODE 1.	<ol style="list-style-type: none">1. COMP OFF2. Freezer FAN OFF3. STEPPING DAMPER CLOSE4. Defrosting heater ON5. DISPLAY LED shows 222	Reset if the temperature of the Defrosting sensor is 50°F(10°C) or more.
Reset	Push the test button once while in TEST MODE 2.	Reset to the default setting	The compressor will Start after a 7-minute delay.

8-2PCBFUNCTION

8-2-1PowerCircuit

1.Powerissuppliedtothecontrolboardatpins1and3ofconnector#1.

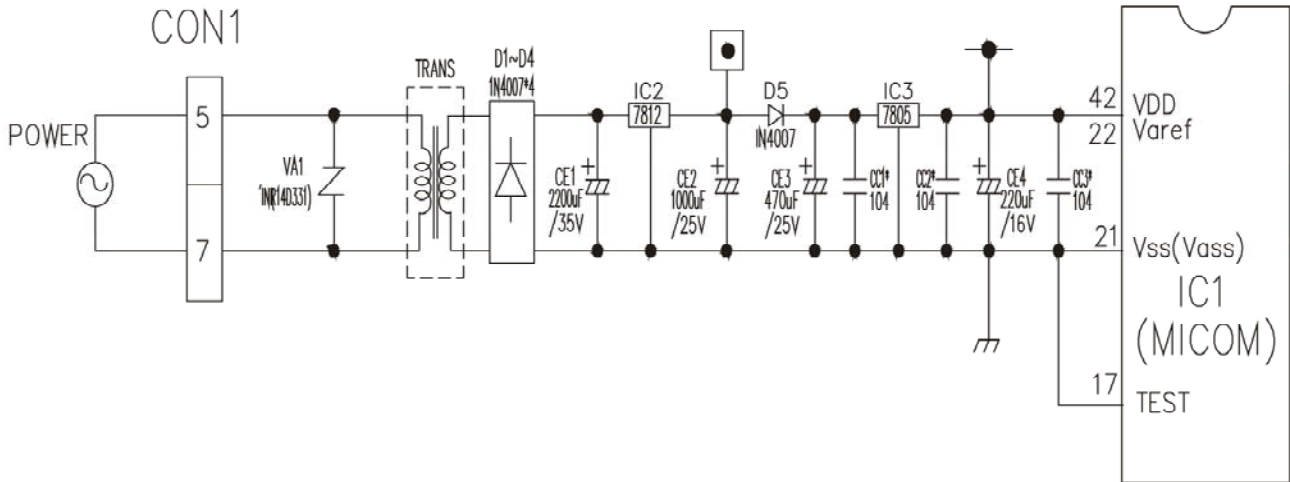

The secondary part of the TRANSFORMER is composed of the power supply for the display, the BLDC FAN Motor drive (15.5 V), the relay drive (12 Vdc) and the MICOM and IC (5 Vdc).

The voltage for each part is as follows:

PART	V A1	CE 2	CE 1	CE 4
VOLTAGE	115 Vac	12 Vdc	15.5 Vdc	5 V

VA1 is a part for preventing over voltage and noise. When 385V or higher power is applied, the inside elements are short-circuited and broken, resulting in blowout of the fuse in order to protect the elements of the secondary part of the TRANSFORMER.

8-2-2 Oscillation Circuit

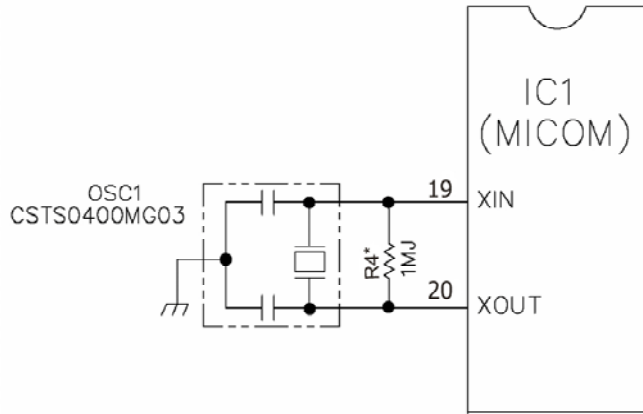

This circuit generates the base clock for calculating time and the synchro clock for transmitting logic elements of the IC1 (MICOM). Be sure to use specific replacement parts, since calculation time may be changed. If changed, the OSC1 SPEC will not work.

gdata from and to the inside in time by the IC1 maybe

8-2-3 Reset Circuit

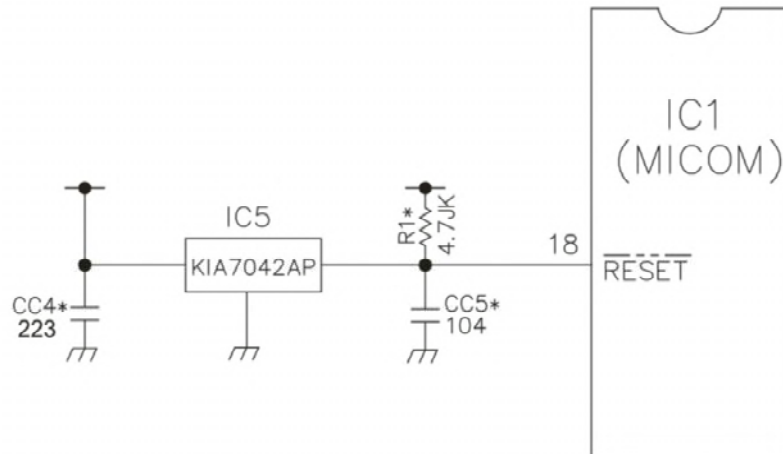

The RESET circuit allows all the functions to start at the initial conditions by initializing various parts, including the RAM inside the MICOM (IC1) when the power is initially supplied or the power supply to the MICOM is restored after a momentary power failure. For the initial 10ms of power supply, LOW voltage is applied to the MICOM RESET terminal. During a normal operation, 5V is applied to the RESET terminal. (If a malfunction occurs in the RESET IC, the MICOM will not operate.)

8-2-4 Load/Buzzer Drive & Open Door Detection Circuit

1. Load Drive Condition Check

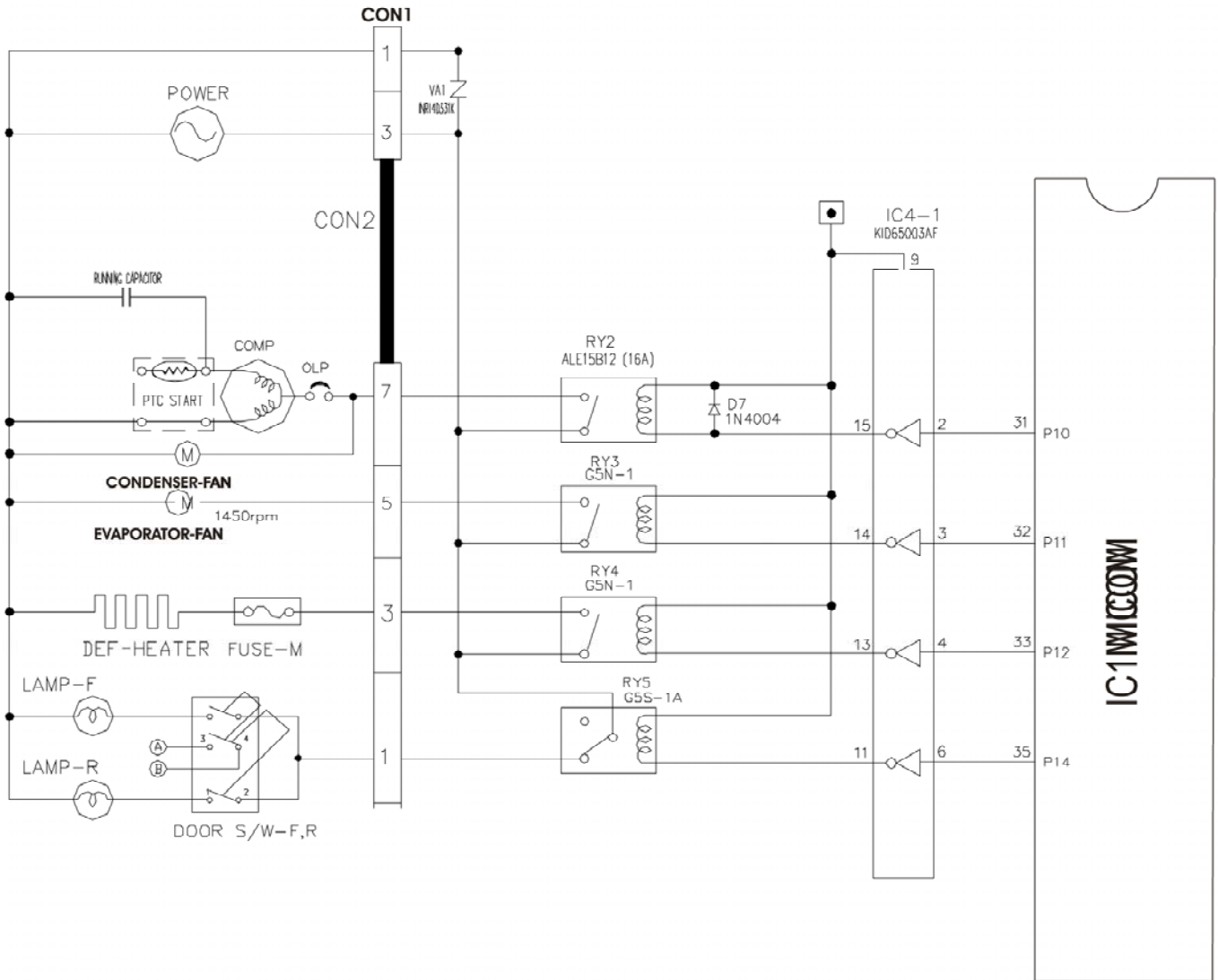

To measure outputs of the control board, check voltages between the pins for the following components:

Circuit	PinNumber	PinNumber	OutputV oltag
Compressor	Con2pin7	Con1pin1	115V AC
Condenserfan	Con2pin7	Con1pin1	115V AC
Evaporatorfan	Con2pin5	Con1pin1	115V AC
Defrostheater	Con2pin3	Con1pin1	115V AC
F,R-lamp	Con2pin1	Con1pin1	115V AC

NOTE: Whenthe door of the freezer/refrigerator is left open for 7 minutes or longer , the lamp of the freezer/refrigerator turns off automatically .

8-2-5 Open Door Circuit (Door Monitor Circuit)

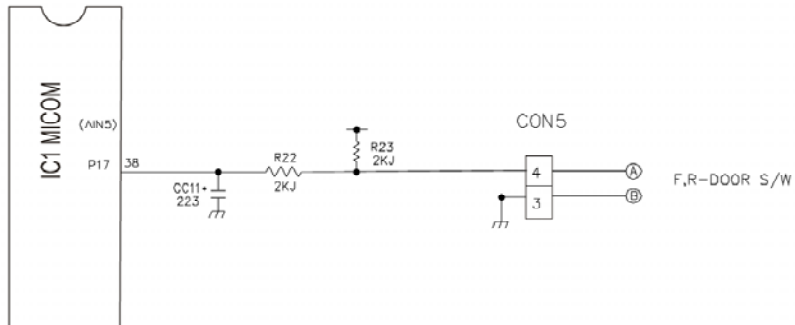

Condition / Measurement Location	Tone (Ding~Dong~) when the button on the display is pushed.	Alarm for open door (beep-beep-beep)	OFF
IC1() (A)			0V
IC1() (B)			0V

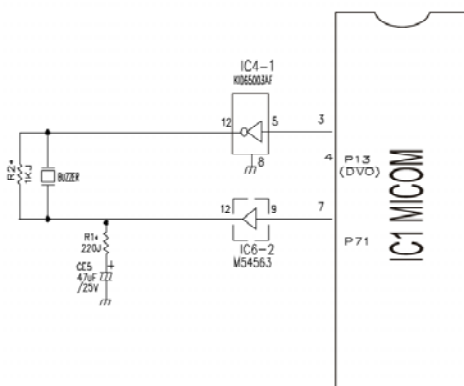

Freezer or Refrigerator	Measurement between pins 4 and 3 at Con5
Both Closed	0volts
One door open	5volts

8-2-6T emperatureSensorCircuit

Voltagesuppliedtoeachsensorwilrangebetween0.5volts-22°F(-30°C)and4.5volts122°F(50°C)dependinguponthe temperatureinthe compartments. A measurementof0voltsindicatesashortinthesensorcircuit. A measurementof5 voltsindicatesanopeninthesensorcircuit.

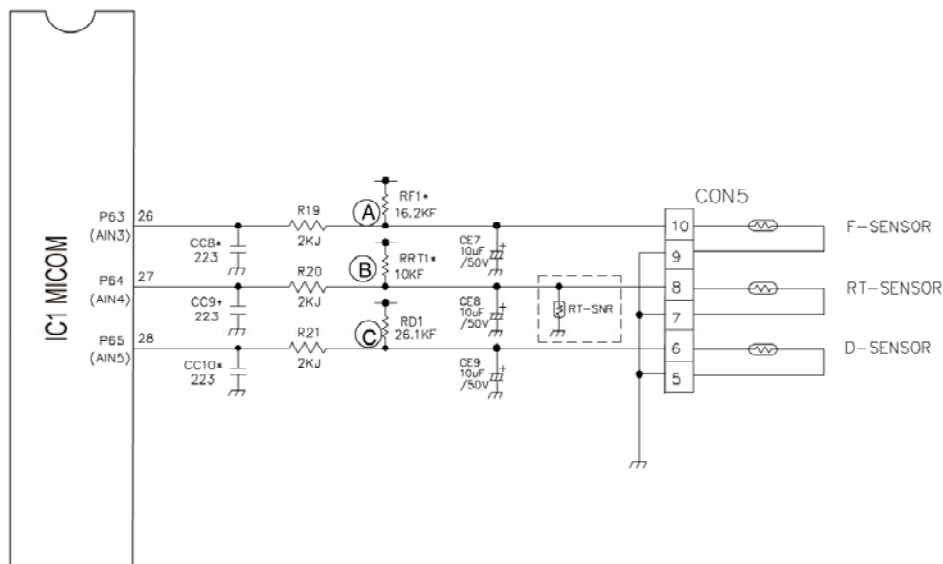

TheupperCIRCUITreadsREFRIGERA TORtemperature,FREEZERT emperature,andDEFROST -SENSORtemperature fordefrostingandtheindoortemperatureforcompensatingforthesurroundingtemperatureintoMICOM. OPENINGorSHORTstateofeachTEMPERA TURESENSORareasfollows:

SENSOR	CHECKPOINT	NORMAL(-30°C~50°C)	SHORT-CIRCUITED	OPEN
FreezerSensor	POINTV(A) oltage	0.5V~4.5V	0V	5V
RefrigeratorSensor	POINTV(B) oltage			
DefrostingSensor	POINTV(C) oltage			

8-2-7 Motor Damper Circuit

A reversible DC motor is used to open and close the damper.

To open the damper, push the test button once.

To close the damper, push the test button twice.

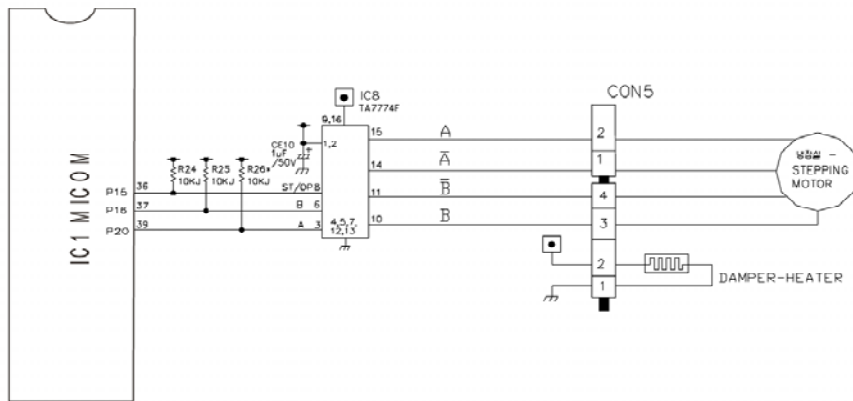

8-2-8 Damper Heater

*The damper heater is attached to the baffle and always will be on if the unit is powered on. The damper heater uses 12VDC.

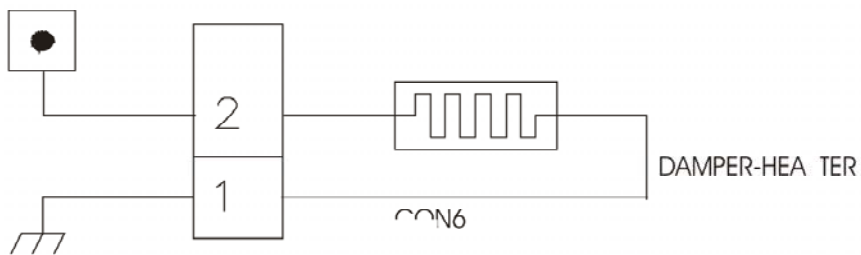

8-2-9 Key Button Input & Display Light On Circuit

LED CHECK MODE: When the COLDER (ADJUST) button in the refrigerator temperature control and the COLDER (ADJUST) button in the freezer temperature control are pushed and held for 1 second or longer, every LED on the display turns on at the same time. When the buttons are released, the previous mode is restored.

Best Model

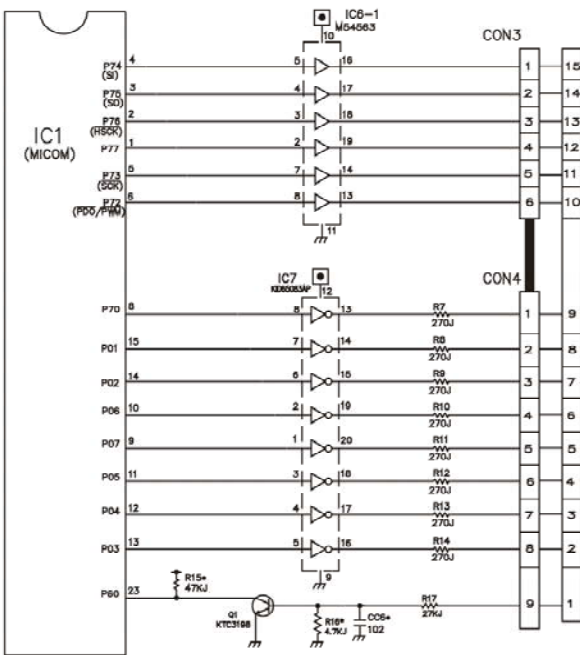

Better Model

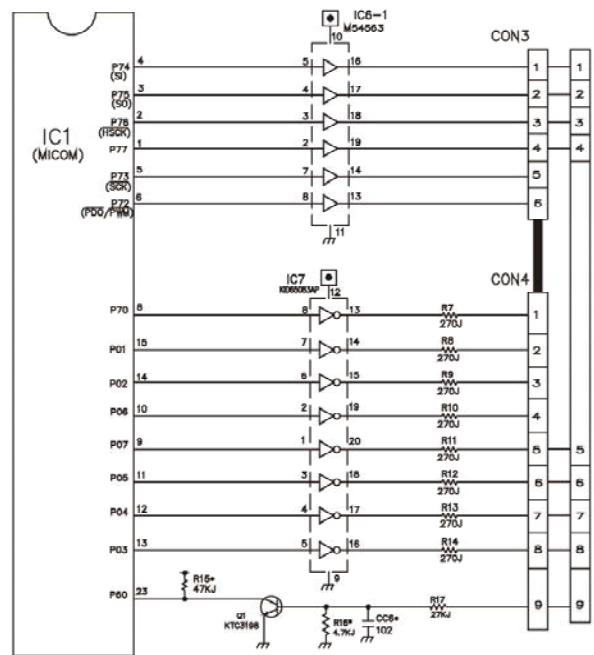

8-5 RESISTANCE SPECIFICATION OF SENSOR

TEMPERATURE	RESISTANCE OF FREEZER SENSOR	RESISTANCE OF REFRIGERATOR & DEFROST SENSOR
- 20 °C (-4 °F)	22.3 KΩ	77 KΩ
- 15 °C (5 °F)	16.9 KΩ	60 KΩ
- 10 °C (14 °F)	13.0 KΩ	47.3 KΩ
- 5 °C (23 °F)	10.1 KΩ	38.4 KΩ
0 °C (32 °F)	7.8 KΩ	30 KΩ
+ 5 °C (41 °F)	6.2 KΩ	24.1 KΩ
+ 10 °C (50 °F)	4.9 KΩ	19.5 KΩ
+ 15 °C (59 °F)	3.9 KΩ	15.9 KΩ
+ 20 °C (68 °F)	3.1 KΩ	13 KΩ
+ 25 °C (77 °F)	2.5 KΩ	11 KΩ
+ 30 °C (86 °F)	2.0 KΩ	8.9 KΩ
+ 40 °C (104 °F)	1.4 KΩ	6.2 KΩ
+ 50 °C (122 °F)	0.8 KΩ	4.3 KΩ

- The resistance of the SENSOR has a $\pm 5\%$ common difference.
- Measure the resistance of the SENSOR after leaving it for over 3 minutes in the measuring temperature. This delay is necessary due to sensor response speed.

8-6T ROUBLESHOOTING

COMPLAINT	SYMPTOM	POSSIBLE CAUSES	SOLUTION
Electronic Display not operating correctly	1. No Display at all	<ol style="list-style-type: none"> 1. Supply voltage not within specifications 2. Open in wiring harness from PWB board 3. Open in door monitor switch circuit 	<ol style="list-style-type: none"> 1. Check supply voltage to refrigerator 2. Check wiring and connectors to PWB board 3. Check door monitor circuit
	2. Partial or abnormal display	<ol style="list-style-type: none"> 1. Supply voltage not within specifications 2. Open in wiring harness from PWB board 	<ol style="list-style-type: none"> 1. Check supply voltage to refrigerator 2. Check wiring and connectors to and from PWB board
Not Cooling	1. Display on but compressor not operating	<ol style="list-style-type: none"> 1. Compressor not operating 2. Open in compressor circuit 	<ol style="list-style-type: none"> 1. Check for compressor operation by using the test key on main circuit board 2. Check for open on OLP, PTC, compressor, wiring, etc.
Not cold enough	2. Display on compressor is operating	<ol style="list-style-type: none"> 1. Condenser fan motor not operating 2. Condenser coils blocked 3. Evaporator fan motor not operating 4. Damper not opening or internal air flow blocked 5. Sensor not operating properly 6. Door not sealing 7. Evaporator Frosted up 8. Sealed System related problem 	<ol style="list-style-type: none"> 1. Check condenser fan motor and wiring circuit 2. Check air flow across condenser 3. Check evaporator fan motor and wiring circuit 4. Check damper motor circuit 5. Check refrigerator and freezer sensors 6. Check for proper door seal 7. Check defrost circuit components
	1. Frosted up in Freezer	<ol style="list-style-type: none"> 1. Open in defrost circuit 2. Defrost sensor not operating correctly 3. Defrost drain clogged 	<ol style="list-style-type: none"> 1. Check defrost heater and circuit using Test Key 2. Check sensor 3. Check drain
Not defrosting			

8-5MAINPWBASSEMBLYANDPARTSLIST

8-5-1MainPWBAsembly

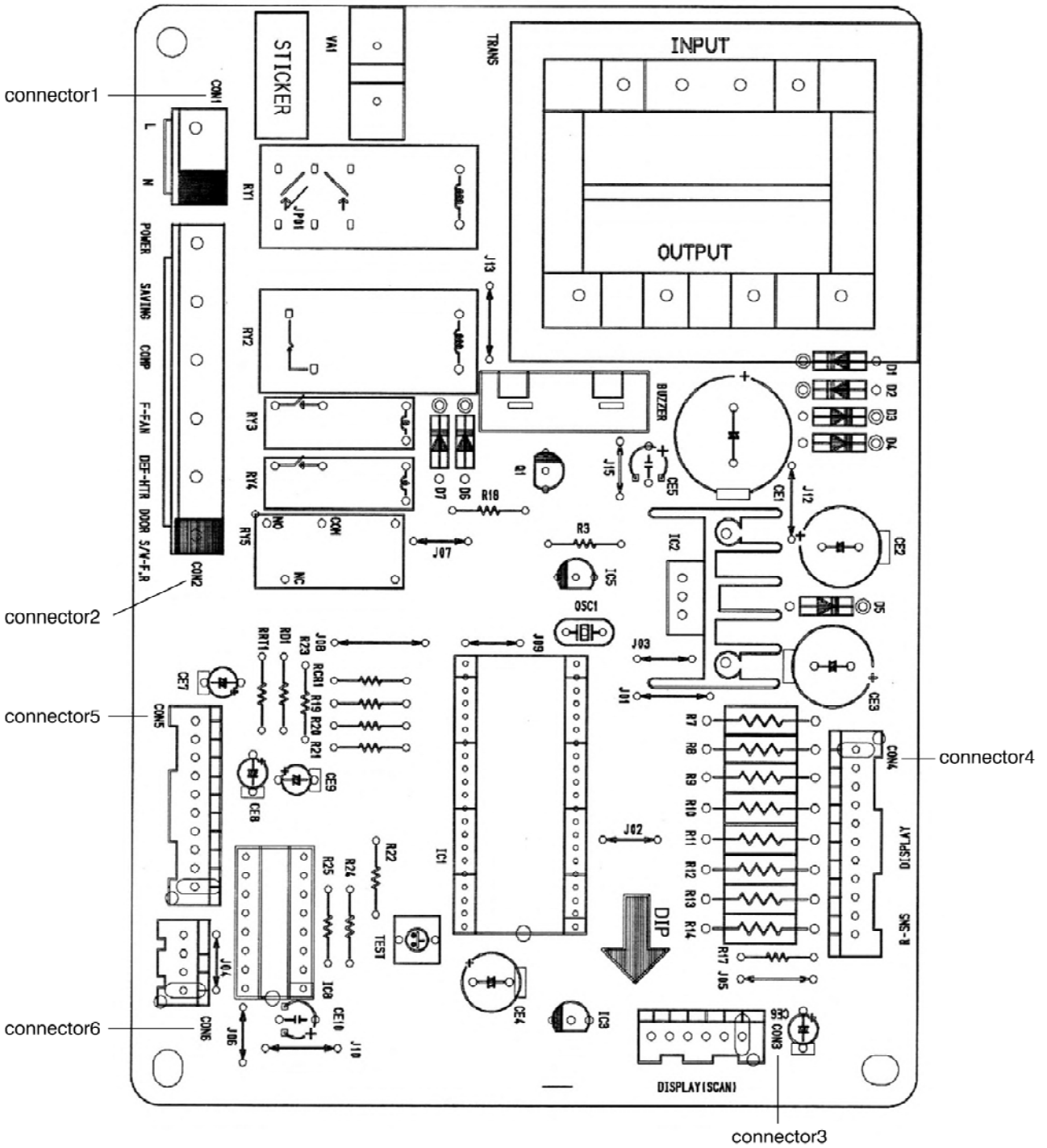

8-5-2 Replacement Parts List

No	P/NO	DESCRIPTION	SPEC	MAKER	REMARK
1	6870JB8078E	PWB(PCB)	H2K-PJT BEST MDL	DOO SAN	T=1.6
2	6170JB2002S	TRANSFORMER,LOW VOLTAGE	117V 15V YES --	TAE SUNG	TRANS
3	6170JB2002T	TRANSFORMER,LOW VOLTAGE	140V 15V YES -	TAE SUNG	TRANS
4	6630AQ9106A	CONNECTOR (CIRC),WAFER	YW396-03AV	YEON HO	CON1
5	6630VM02707	CONNECTOR (CIRC),WAFER	YW396 YEONHO 7P 3.96MM YW396-07 AV < 7P -2,4,6>	YEON HO	CON2
6	6630JB8007E	CONNECTOR (CIRC),WAFER	917784-1 AMP 6P 2.5MM STRAIGHT SN	AMP	CON3
7	6630JB8007K	CONNECTOR (CIRC),WAFER	917786-1 AMP 11P 2.5MM STRAIGHT SN	AMP	CON4
8	6630JB8007J	CONNECTOR (CIRC),WAFER	917786-1 AMP 10P 2.5MM STRAIGHT SN	AMP	CON5
84	6630JB8007C	CONNECTOR (CIRC),WAFER	917782-1 AMP 4P 2.5MM STRAIGHT SN	AMP	CON6
9	01ZZJB2023G	IC,DRAWING	TMP87C846N 42PIN SDIP BK H2K-BEST [MASK]	TOSHIBA	IC1<=01ZZJB2023H>
10	01ZZJB2023J	IC,DRAWING	TMP87C846N 42PIN SDIP BK H2K-BETTER [MASK]	TOSHIBA	IC1<=01ZZJB2023K>
11	01TD777400A	IC,TOSHIBA	TA7774AP 16	TOSHIBA	IC8
12	01KE781200B	IC,KEC	KIA7812PI 12V 1A,KEC - - - -	KEC	IC2
13	01KE781200M	IC,KEC	KIA7812PI 3DIP BK 12V 1A REFOR	KEC	
14	01KE780500A	IC,KEC	KIA78S05P,3PIN,DIP, KEC	KEC	IC3
15	01STLMI001A	IC,STANDARD LOGIC	M54563FP MITSUBISHI 20 R/TP CONVERT	mitsubishi	IC6
16	01KE650030C	IC,KEC	KID65003AF 16SDP BK 7CH DRIVER	KEC	IC4
17	01KE650830B	IC,KEC	KID65083AF FLP-20 BK 7CH DRIVER	KEC	IC7
18	01KE704200A	IC,KEC	KIA7042P 3P BK RESET	KEC	IC5
19	6920000001A	RELAY	ALE15B12 MATSUSHITA 12V 16A 15.6V 1A	NAIS	RY2
20	6920JB2007A	RELAY	VSB-12TB TAKAMISAWA DC12V 60MA 250V 1C	FUJITSU	RY1
21	6920JB2003A	RELAY	G5N-1A OMRON(JAPAN) 12V 16.7MA - -	OMRON	RY3,RY4
22	6920JB2003A	RELAY	G5N-1A OMRON(JAPAN) 12V 16.7MA - -	OMRON	-
23	6920JB2009A	RELAY	G5S-1 OMRON 12V 5A 277V 1C	OMRON	RY5
24	6212W5M002A	RESONATOR,CERAMIC	CST30400 MURATA 4MHZ +/- 0.5% 15PF TP NONE	MURATA	OSC1<J570-00012B>
25	6102JB8001B	VARIATOR	INR14D621 ILJIN UL/VDE BK 620V	IL JIN	VA1
26	6102W5V006A	VARIATOR	INR14D331K ILJIN UL/CSA/VDE BK	IL JIN	VA1
27	0DD400709AA	DIODE,RECTIFIERS	1N4007 TP MOTOROLA - - 1A - - -	DELTA	D1~5
28	0DD400409AC	DIODE,RECTIFIERS	RECTIN4004 TP	DELTA	D6,D7
29	OCE22B6J610	CAPACITOR,AL.ELECTROLYTIC	2200 UF SMS,SG 35V M FL BULK	SAM HWA	CE1
30	OCE1086J610	CAPACITOR,FIXED ELECTROLYTIC	1000UF SMS,SG 35V 20% FL BULK	SAM HWA	-
31	OCE1086H618	CAPACITOR,AL.ELECTROLYTIC	1000 UF SMS,SG 25V M FL TP 5	SAM HWA	CE2
32	OCE4776H618	CAPACITOR,FIXED ELECTROLYTIC	470UF SMS,SG 25V 20% FL TP 5	SAM HWA	CE3
33	OCE4766H618	CAPACITOR,FIXED ELECTROLYTIC	47UF SMS,SG 25V 20% FL TP 5	SAM HWA	CE5
34	OCE2276F638	CAPACITOR,FIXED ELECTROLYTIC	220UF SMS,SG 16V 20% FMS TP 5	SAM HWA	CE4
35	OCE1076H638	CAPACITOR,FIXED ELECTROLYTIC	10UF SMS,SG 50V 20% FMS TP 5	SAM HWA	CE6-CE9
36	OCE1051K638	CAPACITOR,FIXED ELECTROLYTIC	1UF SMS,SG 50V 20% FMS TP 5	SAM HWA	CE10
37	6908JB3002A	BUZZER	BM-20K BUJEDN PIEZO 2KHZ 80DB	BUJEDN	BUZZER
38	OCQ223IN409	CAPACITOR,POLYESTER	0.022 UF D 100V J PE TP	SAM HWA	-
39	OCK102DK96A	CAPACITOR,FIXED CERAMIC(HIGH	1NF 2012 50V 80%,-20% R/TP X7R	SAM HWA	CC6
40	OCK223DK96A	CAPACITOR,FIXED CERAMIC(HIGH	22NF 2012 50V 80%,-20% R/TP X7R	SAM HWA	CC1~4,7~11
41	OCK223DK96A	CAPACITOR,FIXED CERAMIC(HIGH	22NF 2012 50V 80%,-20% R/TP X7R	SAM HWA	-
42	OCK104DK94A	CAPACITOR,FIXED CERAMIC(HIGH	100NF 2012 50V 80%,-20% R/TP F(Y5V)	SAM HWA	CC5
43	OCK104DK94A	CAPACITOR,FIXED CERAMIC(HIGH	100NF 2012 50V 80%,-20% R/TP F(Y5V)	SAM HWA	-
44	OCK104DK94A	CAPACITOR,FIXED CERAMIC(HIGH	0.1UF D 50V 80%,-20% F(Y5V) TA52	SAM HWA	-
45	ORD2700H609	RESISTOR,FIXED CARBON FILM	270 OHM 1/2 W 5.00% TA52	SMART	R7~R14
46	ORD1002G609	RESISTOR,FIXED CARBON FILM	10K OHM 1/4 W 5.00% TA52	SMART	RCR1,R24,R25
47	ORD1000H609	RESISTOR,FIXED CARBON FILM	100 OHM 1/2 W 5.00% TA52	SMART	-
48	ORJ2200E672	RESISTOR,METAL GLAZED(CHIP)	220 OHM 1/8 W 5% 2012 R/TP	ROHM	R1
49	ORJ1001E672	RESISTOR,METAL GLAZED(CHIP)	1K OHM 1/8 W 5% 2012 R/TP	ROHM	R2
50	ORJ2001E672	RESISTOR,METAL GLAZED(CHIP)	2K OHM 1/8 W 5% 2012 R/TP	ROHM	R18
51	ORD2001G609	RESISTOR,FIXED CARBON FILM	2K OHM 1/4 W 5.00% TA52	SMART	R19~23,18
52	ORD2702G609	RESISTOR,FIXED CARBON FILM	27K OHM 1/4 W 5.00% TA52	SMART	R17
53	ORH4701L622	RESISTOR,METAL GLAZED(CHIP)	4.7K OHM 1/8 W 5% 2012 R/TP	ROHM	R6,R16
54	ORJ4702E672	RESISTOR,METAL GLAZED(CHIP)	47K OHM 1/8 W 5% 2012 R/TP	ROHM	R15
55	ORD4701G609	RESISTOR,FIXED CARBON FILM	4.7K OHM 1/4 W 5.00% TA52	SMART	R3
56	ORJ1002E672	RESISTOR,METAL GLAZED(CHIP)	10K OHM 1/8 W 5% 2012 R/TP	ROHM	R5,R26
57	ORJ1000E672	RESISTOR,METAL GLAZED(CHIP)	100 OHM 1/8 W 5% 2012 R/TP	ROHM	-
58	ORJ2702E672	RESISTOR,METAL GLAZED(CHIP)	27K OHM 1/8 W 5% 2012 R/TP	ROHM	-
59	ORN1622G409	RESISTOR,FIXED CARBON FILM	16.2K OHM 1/8 W 1% 2012 R/TP	ROHM	RF1
60	ORJ1004E672	RESISTOR,METAL GLAZED(CHIP)	1M OHM 1/8 W 5% 2012 R/TP	ROHM	R4
61	ORN1002G409	RESISTOR,FIXED METAL FILM	10K OHM 1/4 W 1.00% TA52	SMART	RR1
62	ORN2612G409	RESISTOR,FIXED CARBON FILM	26.1K OHM 1/4 W 1.00% TA52	SMART	RDI
64	ORJ2612E472	RESISTOR,METAL GLAZED(CHIP)	26.1K OHM 1/8 W 1% 2012 R/TP 3	ROHM	RR1
63	6901JB8001A	FUSE ASSEMBLY	KORE-PJT N/S	SAM JU	-
64	3J03565D	FUSE,DRAWING	9A 250V - -	SAM JU	-
65	6500JB3001A	SENSOR	JAMES-TEC RT_SENSOR	JAMES TEC	RT-SNR
66	OTR106009AC	TRANSISTOR	KRA106M(KRA2206) TP KEC	KEC	-
67	OTR106009AF	TRANSISTOR	KRC 106M KEC	KEC	-
68	OTR319809AA	TRANSISTOR	KTC3198-TP-Y (KTC1815)KEC	KEC	Q1
69	6600RR1001Z	SWITCH,TACT	JTP1280A6 JEIL 12V DC 50MA	JEIL	TEST
70	6854B50001A	JUMP WIRE	0.6MM 52MM TP TAPING SN	-	OP1<10MM>
71	6854B50001A	JUMP WIRE	0.6MM 52MM TP TAPING SN	-	OP2<10MM>
72	6854B50001A	JUMP WIRE	0.6MM 52MM TP TAPING SN	-	-
74	6854B50001A	JUMP WIRE	0.6MM 52MM TP TAPING SN	-	J01,05,10,12,13<10MM>
75	6854B50001A	JUMP WIRE	0.6MM 52MM TP TAPING SN	-	JP01<10MM>
77	6854B50001A	JUMP WIRE	0.6MM 52MM TP TAPING SN	-	J08<12.5MM>
78	6854B50001A	JUMP WIRE	0.6MM 52MM TP TAPING SN	-	J02~04,06,07,09,15<8MM>
79	4920JB3007A	HEAT SINK	23.3*17*25 DRIVE IC STR R-S64,65,73 2PIN	-	<IC2>
80	1SBF0302418	SCREW TAP TITE(S),BINDING HEAD	+ D3.0 L8.0 MSWR3/FZY	-	-
81	9VWF0120000	SOLDER<ROSIN WIRE> RS0	D1.20	HEE SUNG	-
82	49111004	SOLDER,SOLDERING	H63A	-	-
83	59333105	FLUX	SGJ0.825-0.830 KOREA F.H-206	KOKI	-
85	6170JB2002U	TRANSFORMER,LOW VOLTAGE	240V 15V YES --	TAE SUNG	TRANS
86	6170JB2002V	TRANSFORMER,LOW VOLTAGE	260V 15V YES -	TAE SUNG	TRANS



REPAIR PARTS LIST

MODELS No.

- 795.73962304
- 795.73969304
- 795.73964304
- 795.73966304
- 795.73963304
- 795.75952402
- 795.75959402
- 795.75954402
- 795.73262304
- 795.73269304
- 795.73264304
- 795.73266304
- 795.73263304
- 795.75252402
- 795.75259402
- 795.75254402

To call
Toll Free
For Parts:

1-800-366-PART
(1-800-366-7278)

For Service:

1-800-4-MY-HOME
(1-800-469-4663)

The model number of your refrigerator is found on the serial plate inside.

All repair parts listed are available for immediate purchase or special order when you visit your nearest Sears Service Center, or the Service Department at most Sears stores. To order parts by phone, call the toll free parts number listed to the left.

When requesting service or ordering parts, always provide the following information:

- Product Type •Part Number
- Model Number •Part Description

Get it fixed, at your home or ours!

Your Home

For repair -in your home- of all major brand appliances, lawn and garden equipment, or heating and cooling systems, no matter who made it, no matter who sold it!

For the replacement parts, accesories and owner's manuals that you need to do-it-yourself.

For Sears professional installation of home appliances and items like garage door openers and water heaters.

1-800-4-MY-HOME® (1-800-469-4663)

Call anytime, day or night (U.S.A. and Canada)

www.sears.com www.sears.ca

Our Home

For repair of carry-in items like vacuums, lawn equipment, and electronics, call or go on-line for the location of your nearest **Sears Parts & Repair Center.**

1-800-488-1222

Call any time, day or night (U.S.A. only)

www.sears.com

To purchase a protection agreement (U.S.A.) maintenance agreement (Canada) on a product serviced by Sears:
1-800-827-6655 (U.S.A.) **1-800-361-6665** (Canada)

Parapedirserviciodereparación domicilio, y para ordenar piezas:
1-888-SU-HOGARSM
(1-888-784-6427)

Au Canada pour service en français:
1-888-LE-FOYERSM
(1-888-533-6937)
www.sears.ca



Sears, Roebuck and Co., Hoffman Estates, IL 60179 U.S.A.

© Registered Trademark / SM Trademark/SM Service Mark of Sears, Roebuck and Co.
© Marca Registrada/ SM Marca de Fábrica/ SM Marca de Servicio de Sears, Roebuck and Co.
© Marque de commerce/SM Marque déposée de Sears, Roebuck and Co.

© Sears, Roebuck and Co.

ICE MAKER PARTS

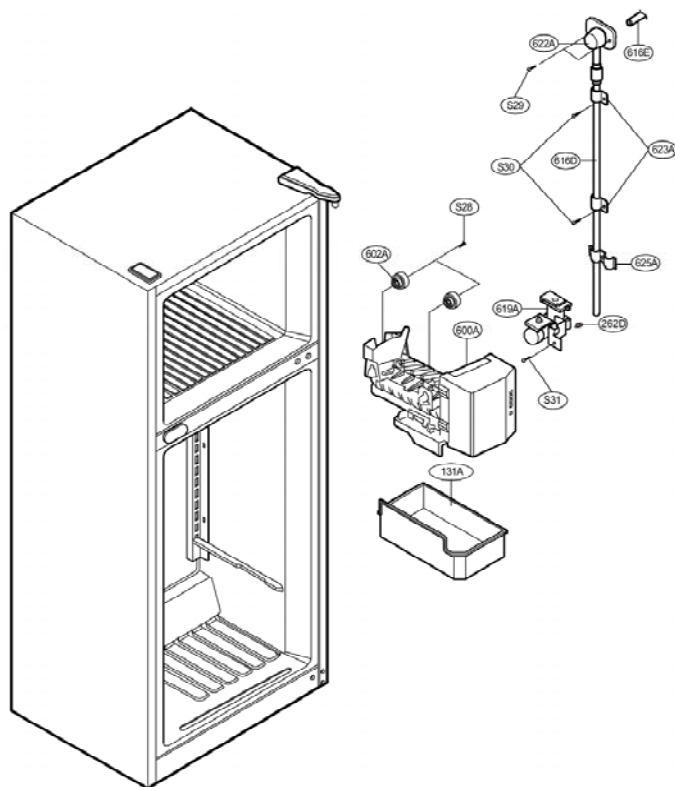

LOC #	PART NUMBER	DESCRIPTION
625A	4930JA3054A	HOLDER, PIPE
622A	5210JJ3002A	TUBE, INLET
616E	5210JJ3003B	TUBE, INJECT
616D	5210JA3005J	TUBE, PE
623A	4770JA3001A	BAND (MECH)
619A	5220JA2009D	VALVE, WATER
600A	5989JA0002E	ICE MAKER ASSEMBLY
602A	4930JA3037A	HOLDER BRACKET
262D	4004JA3002A	CLIP
131A	5074JJ1007A	BANK, ICE
S28	3J05696W	SCREW, DRAWING
S29	1SZZJA3009A	SCREW, DRAWING
S30	4J00415D	SCREW, DRAWING
S31	1MTC0402618	SCREW, MACHINE

CAUTION: Use the part number to order part, not the location number.

#EV# **CASE PARTS**

PART NUMBER BY MODEL

LOC #	PART NUMBER BY MODEL				DESCRIPTION
	795.75252402 795.75259402 795.75254402	795.75952402 795.75959402 795.75954402	795.73262304 795.73269304 795.73264304 795.73266304 795.73263304	795.73962304 795.73969304 795.73964304 795.73966304 795.73963304	
104B	4930JJ3007A	4930JJ3007A	4930JJ3007A	4930JJ3007A	HOLDER,BRACKET
105A	5251JA3003B	5251JA3003B	5251JA3003B	5251JA3003B	DRAIN ASSEMBLY,PIPE-Z
105F	5070JJ3002A	5070JJ3002A	5070JJ3002A	5070JJ3002A	SKIRT,LOWER
106A	4779JA2003A	4779JA2003A	4779JA2003A	4779JA2003A	LEG ASSEMBLY,ADJUST
113A	4930JJ2008A	4930JJ2008A	4930JJ2008A	4930JJ2008A	HOLDER,BRACKET
113B	4930JJ2005A	4930JJ2005A	4930JJ2005A	4930JJ2005A	HOLDER,GASKET
113C	4970JA3016A	4970JA3016A	4970JA3016A	4970JA3016A	SPRING,W
113D	4986JJ2003A	4986JJ2003A	4986JJ2003A	4986JJ2003A	GASKET,BETTA
120A	4995JJ1003D	4995JJ1003H	4995JJ1003C	4995JJ1003G	CONTROL BOX ASSEMBLY,R
120B	4994JJ0001A	4994JJ0002A	4994JJ0001A	4994JJ0002A	CONTROL BOX,R
145A	4930JJ2003A	4930JJ2003A	4930JJ2003A	4930JJ2003A	HOLDER,SHELF
145B	4930JJ2004A	4930JJ2004A	4930JJ2004A	4930JJ2004A	HOLDER,SHELF
158A	3550JJ2019B	3550JJ2019B	3550JJ2019B	3550JJ2019B	COVER,LAMP
158C	3550JJ2019A	3550JJ2019A	3550JJ2019A	3550JJ2019A	COVER,LAMP
175A	N/A	N/A	3391JJ2005A	3391JJ2005A	TRAY ASSEMBLY,PIZZA
281B	4775JJ2003B	4775JJ2003B	4775JJ2003B	4775JJ2003B	HINGE ASSEMBLY,U
282B	4775JJ2002A	4775JJ2002A	4775JJ2002A	4775JJ2002A	HINGE ASSEMBLY,C
282C	1PZZJJ3002F	1PZZJJ3002F	1PZZJJ3002F	1PZZJJ3002F	PIN,DRAWING
301A	5421JJ0002A	5421JJ0003A	5421JJ0002A	5421JJ0003A	EVAPORATOR ASSEMBLY
304A	3551JJ2008B	3551JJ2008B	3551JJ2008B	3551JJ2008B	COVER ASSEMBLY,BACK-M/C
305B	4580JJ3001A	4580JJ3001A	4580JJ3001A	4580JJ3001A	ROLLER
305B	4580JJ3001A	4580JJ3001A	4580JJ3001A	4580JJ3001A	ROLLER
305C	4J04238A	4J04238A	4J04238A	4J04238A	PIN,DRAWING
305C	4J04238A	4J04238A	4J04238A	4J04238A	PIN,DRAWING
307A	2521JJ8004A	2521JJ8004A	2521JJ8004A	2521JJ8004A	COMPRESSOR,SET ASSEMBLY
308A	6748JJ8002A	6748JJ8002A	6748JJ8002A	6748JJ8002A	P.T.C ASSEMBLY
309A	6750JJ8002A	6750JJ8002A	6750JJ8002A	6750JJ8002A	O.L.P
310A	3550JJ8003A	3550JJ8003A	3550JJ8003A	3550JJ8003A	COVER,P.T.C
312A	5040JA3067A	5040JA3067A	5040JA3067A	5040JA3067A	RUBBER,SEAT
314A	4620JA3009A	4620JA3009A	4620JA3009A	4620JA3009A	STOPPER,COMP
315A	3103JJ1001J	3103JJ1001K	3103JJ1001J	3103JJ1001K	COMP BASE ASSEMBLY,STD
317A	5851JJ2002B	5851JJ2002B	5851JJ2002B	5851JJ2002B	DRIER ASSEMBLY
318A	4930JJ3002A	4930JJ3002A	4930JJ3002A	4930JJ3002A	HOLDER,DRIER
319A	3390JJ0003A	3390JJ0003A	3390JJ0003A	3390JJ0003A	TRAY,DRIP
319C	4974JJ1009A	4974JJ1009A	4974JJ1009A	4974JJ1009A	GUIDE,FAN
323B	5403JJ1003A	5403JJ1003A	5403JJ1003A	5403JJ1003A	CONDENSER ASSEMBLY,WIRE
327A	5006JA3034A	5006JA3034A	5006JA3034A	5006JA3034A	CAP,RAIN PIPE
328A	4J04328A	4J04328A	4J04328A	4J04328A	RUBBER,DAMPING
328A	4J04328A	4J04328A	4J04328A	4J04328A	RUBBER,DAMPING
328B	4J03020A	4J03020A	4J03020A	4J03020A	RUBBER,DAMPING
329C	5901JJ1004B	5901JJ1004B	5901JJ1004B	5901JJ1004B	FAN ASSEMBLY
401A	4781JK2001A	4781JK2001A	4781JK2001A	4781JK2001A	CONTROLLER ASSEMBLY
409B	6912JK2002A	6912JK2002A	6912JK2002A	6912JK2002A	LAMP,(INCANDESCENT)
410G	0CZZJB2003H	0CZZJB2003H	0CZZJB2003H	0CZZJB2003H	CAPACITOR,DRAWING
411A	6411JK1006A	6411JK1006A	6411JK1006A	6411JK1006A	POWER CORD ASSEMBLY
418A	5300JK1003J	5300JK1003D	5300JK1003J	5300JK1003D	HEATER,SHEATH
420A	4680JK1001B	4680JK1001B	4680JK1001B	4680JK1001B	MOTOR,(MECH),COOLING
501A	6871JB1185B	6871JB1185B	6871JB1185A	6871JB1185A	PWB(PCB) ASSEMBLY,MAIN
501F	3550JJ2016A	3550JJ2016A	3550JJ2016A	3550JJ2016A	COVER,PWB
503B	6871JB2044A	6871JB2044A	6871JB2043A	6871JB2043A	PWB(PCB) ASSEMBLY,DISPLAY
503C	6871JB2044B	6871JB2044B	6871JB2043B	6871JB2043B	PWB(PCB) ASSEMBLY,DISPLAY
503D	3110JJ2002A	3110JJ2002A	3110JJ2001A	3110JJ2001A	CASE,DISPLAY
610A	3550JL2004A	3550JL2004A	3550JL2004A	3550JL2004A	COVER,SENSOR
612A	N/A	N/A	4974JJ2006A	4974JJ2006A	GUIDE,RAIL
619B	3550JJ2024A	3550JJ2024A	3550JJ2024A	3550JJ2024A	COVER,VALVE
903B	4930JJ2021A	4930JJ2021A	4930JJ2021A	4930JJ2021A	HOLDER,COVER LOWER
903D	6500JK1003A	6500JK1003A	6500JK1003A	6500JK1003A	SENSOR
903E	6500JK1004A	6500JK1004A	6500JK1004A	6500JK1004A	SENSOR
B01	J351-00004L	J351-00004L	J351-00004L	J351-00004L	SCREW,DRAWING
B02	J351-00004R	J351-00004R	J351-00004R	J351-00004R	SCREW,DRAWING
B03	1BZZJA2002A	1BZZJA2002A	1BZZJA2002A	1BZZJA2002A	BOLT,DRAWING
B04	1BZZJA2002A	1BZZJA2002A	1BZZJA2002A	1BZZJA2002A	BOLT,DRAWING
S01	4J00415D	4J00415D	4J00415D	4J00415D	SCREW,DRAWING
S02	4J00415D	4J00415D	4J00415D	4J00415D	SCREW,DRAWING
S04	4J00415D	4J00415D	4J00415D	4J00415D	SCREW,DRAWING
S05	4J00415D	4J00415D	4J00415D	4J00415D	SCREW,DRAWING
S06	4J00415D	4J00415D	4J00415D	4J00415D	SCREW,DRAWING
S07	1SAAC-0002A	1SAAC-0002A	1SAAC-0002A	1SAAC-0002A	SCREW,DRAWING
S08	1SZZJJ3017A	1SZZJJ3017A	1SZZJJ3017A	1SZZJJ3017A	SCREW,DRAWING
S09	1SZZJA3016A	1SZZJA3016A	1SZZJA3016A	1SZZJA3016A	SCREW,DRAWING
S10	4J00415D	4J00415D	4J00415D	4J00415D	SCREW,DRAWING
S13	1SZZJJ3010A	1SZZJJ3010A	1SZZJJ3010A	1SZZJJ3010A	SCREW,DRAWING
S14	3J05696W	3J05696W	3J05696W	3J05696W	SCREW,DRAWING
S15	4J00415D	4J00415D	4J00415D	4J00415D	SCREW,DRAWING
S16	4J01424D	4J01424D	4J01424D	4J01424D	SCREW,DRAWING
S17	4J00415D	4J00415D	4J00415D	4J00415D	SCREW,DRAWING
S18	1TCL0302818	1TCL0302818	1TCL0302818	1TCL0302818	SCREW,TAPPING,COUNTER SUNK HEAD
S38	1BZZJA2002A	1BZZJA2002A	1BZZJA2002A	1BZZJA2002A	SCREW,DRAWING

LOC #	PART NUMBER	MODEL(S)	795.75259402	795.75254402	795.75254402	795.75959402	795.75952402	795.75954402	795.73266304	795.73263304	795.73269304	795.73262304	795.73264304	795.73966304	795.73963304	795.73969304	795.73964304	
103A	3650JJ2003	L	A	F	L	E	F	L	M	L	E	F	M	L	M	E	F	HANDLE, BACK
103B	3650JJ2003	M	A	B	M	A	B	M	M	M	A	B	M	M	M	A	B	HANDLE, BACK
103C	3551JJ1015	F	A	D	E	A	C	F	F	F	B	D	F	F	E	A	C	COVER ASSEMBLY,LOWER
281A	3550JJ2013	C	A	B	C	A	B	F	C	C	A	B	C	C	C	A	B	COVER, HINGE
282E	5006JJ2001	F	A	E	F	A	E	F	F	F	A	E	F	F	F	A	E	CAP, HINGE
282H	5006JJ3004	E	A	A	E	A	A	E	E	E	A	A	E	E	E	A	A	CAP, HINGE
283B	4775JJ2013	B	B	B	B	B	A	B	B	B	B	B	B	B	B	B	B	HINGE ASSEMBLY, L
406B	6600JB2004	B	A	A	B	A	A	B	B	B	A	A	B	B	B	A	A	SWITCH, (PUSH)
903A	3550JJ0006	C	A	B	C	A	B	C	C	C	A	B	C	C	C	A	B	COVER, LOWER
903A	3550JJ0005				C	A	B											COVER LOWER

CAUTION: Use the part number to order part, not the location number.

TO FIND OUT YOUR MODEL PART NUMBER, YOU MUST TO SELECT THE PART NUMBER AND CHOOSE THE LETTER THAT IS ALIGNED WITH THE MODEL THAT CORRESPOND TO YOUR REFRIGERATOR

REFRIGERATOR PARTS

CAUTION: Use the part number to order part, not the location number .

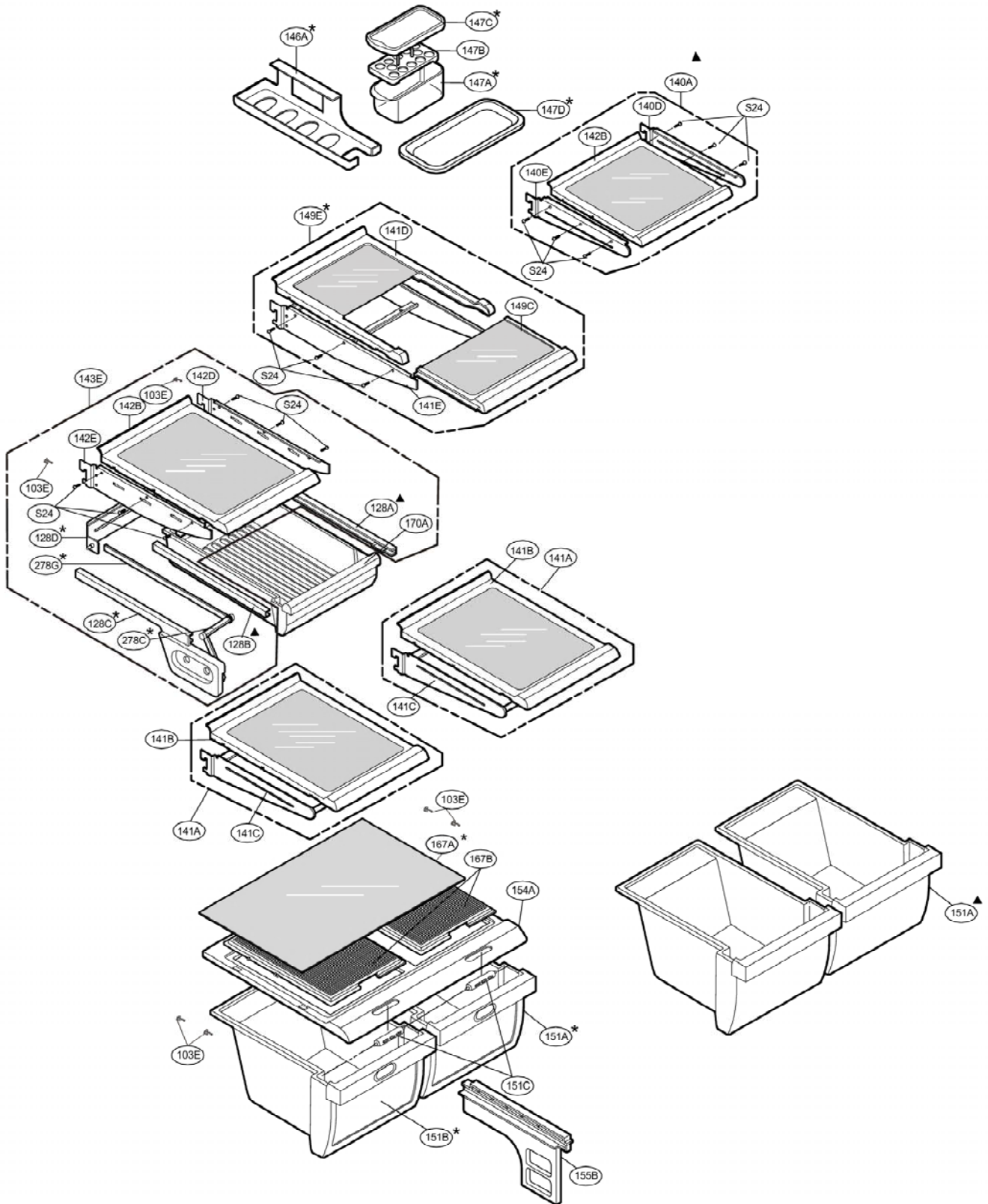

* : MODEL(S): 795.73962304, 795.73969304, 795.73964304, 795.73966304, 795.73963304, 795.73262304, 795.73269304, 795.73264304, 795.73266304, 795.73263304
▲ : MODEL(S): 795.75952402, 795.75959402, 795.75954402, 795.75252402, 795.75259402, 795.75254402

DOOR PARTS

CAUTION: Use the part number to order part, not the location number.

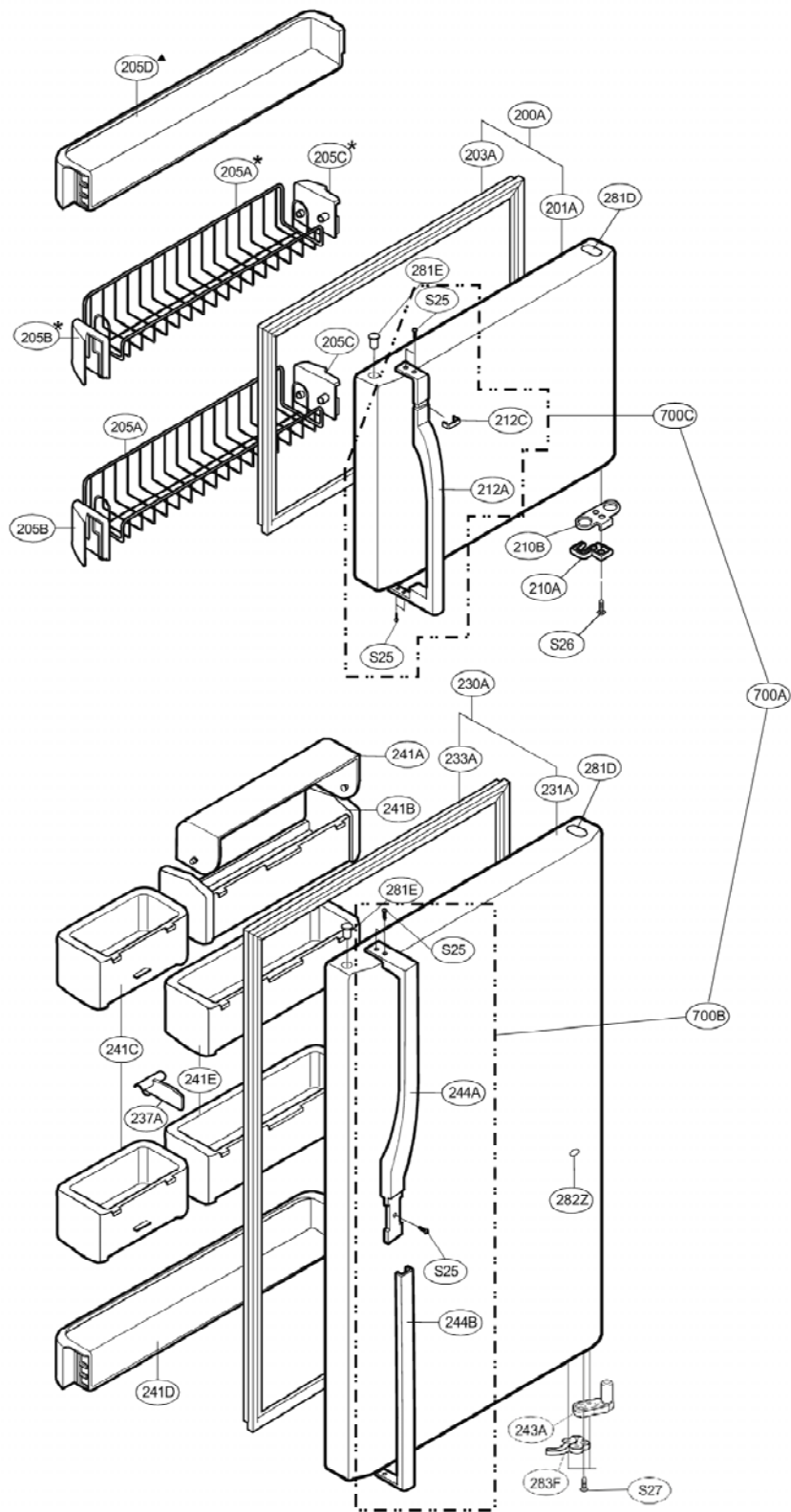

* : MODEL(S): 795.73962304, 795.73969304, 795.73964304, 795.73966304, 795.73963304, 795.73262304, 795.73269304, 795.73264304, 795.73266304, 795.73263304
▲ : MODEL(S): 795.75952402, 795.75959402, 795.75954402, 795.75252402, 795.75259402, 795.75254402



*'You Can Count on me . . .
to Work Safely.'*