

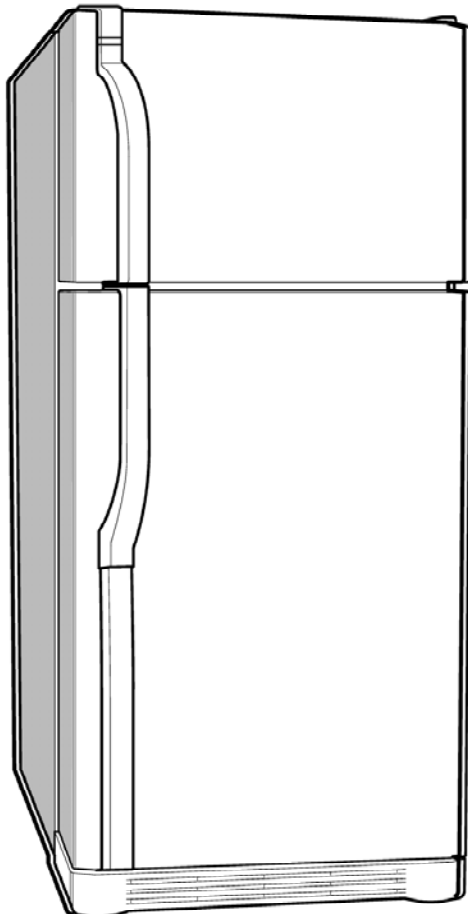

REFRIGERATOR SERVICE MANUAL

CAUTION
BEFORE SERVICING THE UNIT,
READ THE SAFETY PRECAUTIONS IN THIS MANUAL.



Model #s:
795.73259303
795.73252303
795.73254303
795.73959303
795.73952303
795.75954303

CONTENTS

SPECIFICATIONS	3
PARTS IDENTIFICATION	4
DISASSEMBLY	5-6
DOOR.....	5
DOOR SWITCH.....	5
FAN AND FAN MOTOR.....	6
DEFROST CONTROL ASSEMBLY.....	6
LAMP.....	6
CONTROL BOX-R.....	6
ADJUSTMENT	7-8
COMPRESSOR.....	7
PTC-STARTER.....	7
OLP (OVERLOAD PROTECTOR).....	8
TO REMOVE THE COVER PTC.....	8
CIRCUIT DIAGRAM	9-10
TROUBLESHOOTING	11-15
COMPRESSOR AND ELECTRIC COMPONENTS.....	11
PTC AND OLP.....	12
OTHER ELECTRIC COMPONENTS.....	13
SERVICE DIAGNOSIS CHART.....	14
REFRIGERANT CYCLE.....	15
OPERATION PRINCIPLE AND REPAIR METHOD OF ICE MAKER	17-20
DESCRIPTION OF FUNCTION & CIRCUIT OF MICOM	21-33
REFRIGERATOR EXPLODED VIEW & SERVICE PARTS LIST	34- 39

SAFETY PRECAUTIONS

Please read the following instructions before servicing your refrigerator.

1. Check the refrigerator for current leakage.
2. To prevent electric shock, unplug before servicing.
3. Always check line voltage and amperage.
4. Use standard electrical components.
5. Don't touch metal products in the freezer with wet hands. This may cause frostbite.
6. Prevent water from spilling onto electric elements or the machine parts.
7. Close the top door before opening the bottom door. Otherwise, you might hit your head when you stand up.
8. When tilting the refrigerator, remove any materials on the refrigerator, especially the thin plates (ex. glass shelf or books.)
9. When servicing the evaporator, wear cotton gloves. This is to prevent injuries from the sharp evaporator fins.
10. Service on the refrigerator should be performed by a qualified technician. Sealed system repair must be performed by a CFC certified technician.

1. SPECIFICATIONS

1-1 DISCONNECT POWER CORD BEFORE SERVICING IMPORTANT – RECONNECT ALL GROUNDING DEVICES

All parts of this appliance capable of conducting electrical current are grounded. If grounding wires, screws, straps, clips, nuts or washers used to complete a path to ground are removed for service, they must be returned to their original position and properly fastened.

1-2 IMPORTANT NOTICE

This information is intended for use by individuals possessing adequate backgrounds of electrical, electronic and mechanical experience. Any attempt to repair a major appliance may result in personal injury and property damage. The manufacturer or seller cannot be responsible for the interpretation of this information, nor can it assume any liability in connection with its use.

1-3 ELECTRICAL SPECIFICATIONS

Temperature Control (Position : MID)	8-(-6)°F
Defrost Control	7 hrs.
Defrost Thermostat	50°F
Electrical Rating :115V. AC, 60 Hz.	1-5 Amp.
Maximum Current Leakage	0.5 mA
Maximum Ground Path Resistance	0.14 Ohms
Energy Consumption	19 cu.ft : 405 kWh/yr(Energy star)
	22 cu.ft : 445 kWh/yr(Energy star)

1-4 NO LOAD PERFORMANCE CONTROL POSITION: MID/MID

And Ambient of :	70°F	90°F
Fresh Food, °F	33-41	33-41
Frozen Food, °F	(-4)-4	(-4)-4
Percent Running Time	25-35	45-60

1-5 REFRIGERATION SYSTEM

Minimum Compressor Capacity Vacuum	21 in.
Minimum Equalized Pressure	
@ 70°F	49 PSIG
@ 90°F	56 PSIG
Refrigerant - R - 134a	5.47 oz.
Compressor	700 BTU/hr

1-6 INSTALLATION

Clearance must be provided at top, sides and rear of the refrigerator for air circulation.

AT TOP	1 in
AT SIDES	1/8 in
AT REAR	1 in

PERFORMANCE DATA (NORMAL OPERATING CONDITIONS)			
AMB	WATTS	SYSTEM PRESSURE (PSIG)	
		HIGH SIDE	LOW SIDE
70°F	98 (+10 / -10)	98 (+5 / -3)	(-5) to (-2)
90°F	98 (+10 / -10)	132 (+3 / -3)	(-4) to 1
110°F	103 (+5 / -5)	180 (+5 / -5)	(-2) to 3

1-7 REPLACEMENT PARTS

Relay	6748JJ8002A
Overload	6750JJ8002A
Defrost Thermostat	6615JB2005B
Defrost Heater	19cu. ft : 5300JK1003D
	22cu. ft : 5300JK1003J
Evaporator Fan Motor	4681JB1016J
Capacitor	OCZZJB2003F
Compressor (Hi-Side)	2521JJ8004A
Evaporator (Lo-Side)	19cu. ft : 5421JJ0003A
	22cu. ft : 5421JJ0002A
Condenser	5403JJ1003A
Dryer	5851JJ2002K
Condenser Fan Motor	4681JK1001B
Temperature Control	6871JB2043A,B
Main Control	6871JB1185A

1-8 AIR FLOW / CIRCULATION D' AIR

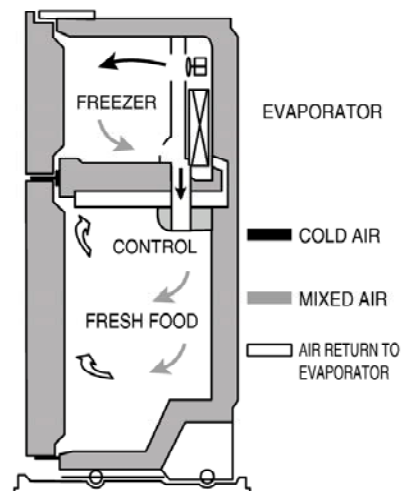
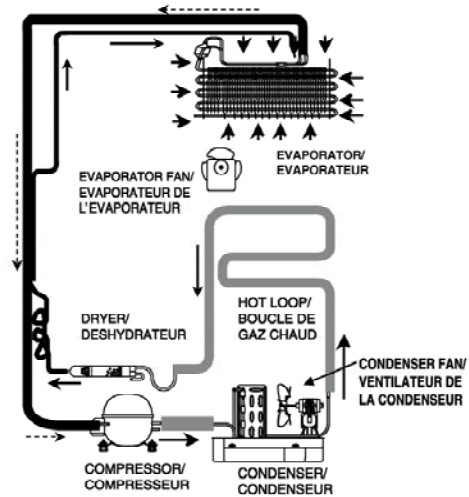

2. PARTS IDENTIFICATION

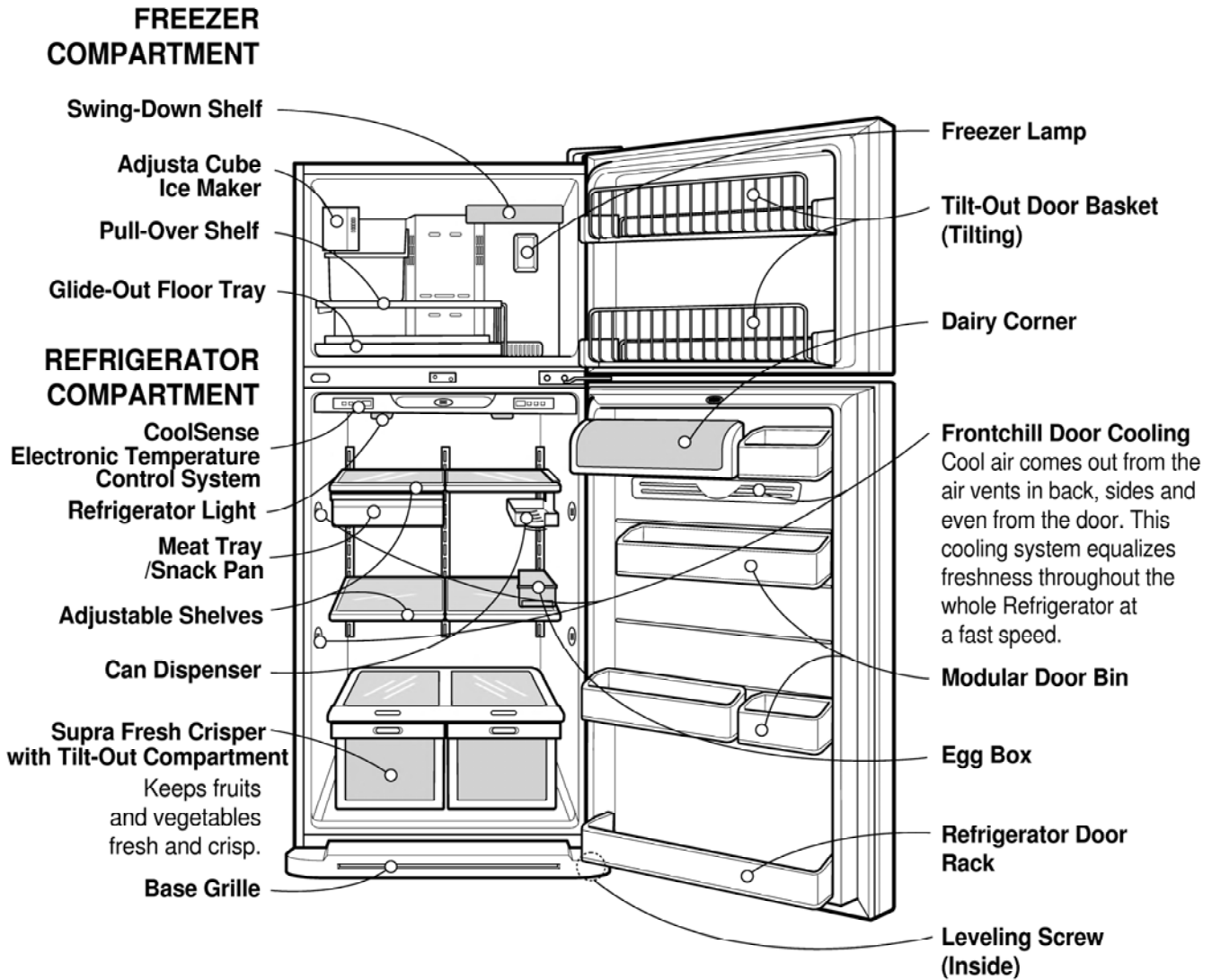

3. DISASSEMBLY

3-1 DOOR

● Freezer Door

1. Remove the hinge cover by pulling it upwards.
2. Loosen hexagonal bolts attaching the upper hinge to the body and lift the freezer door.

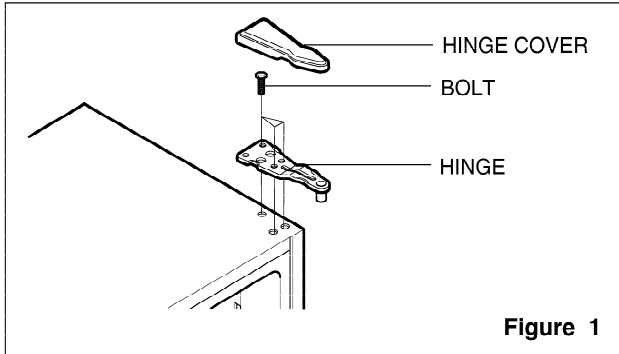

3. Pull out the door gasket to remove from the door foam assembly.

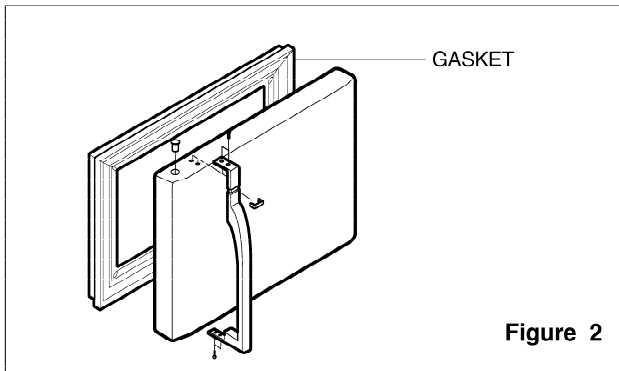

● Refrigerator Door

1. Loosen hexagonal bolts attaching the lower hinge to the body to remove the refrigerator door only.

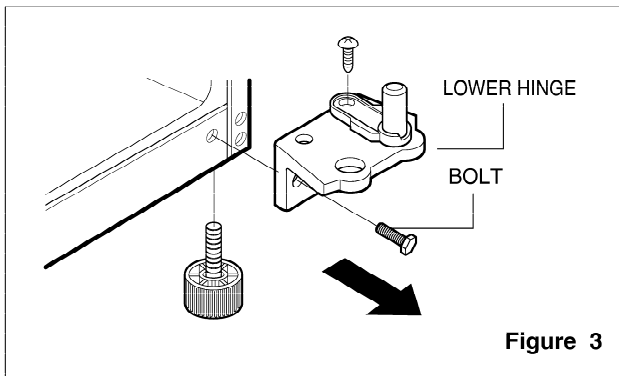

2. Pull out the door gasket to remove from the door foam assembly.

3-2 DOOR SWITCH

1. To remove the door switch, pull it out with a slotted-type driver as shown in (Figure 4).
2. Disconnect the lead wire from the switch.

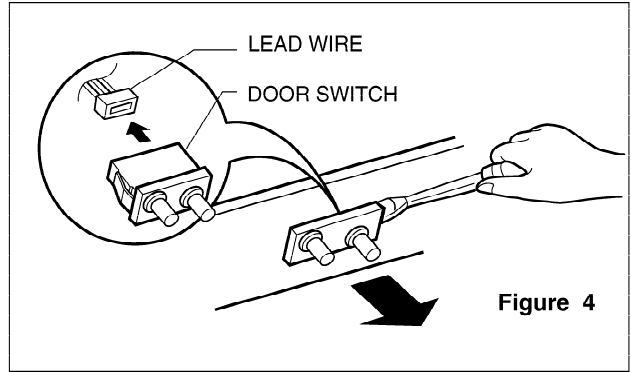

3-3 FAN AND FAN MOTOR

1. Remove the freezer shelf. (If your refrigerator has an ice maker, remove the ice maker first)
2. Remove the grille by pulling it out and by loosening a screw.
3. Remove the Fan Motor assembly by loosening 4 screws and disassemble the shroud.
4. Pull out the fan and separate the Fan Motor and Bracket.

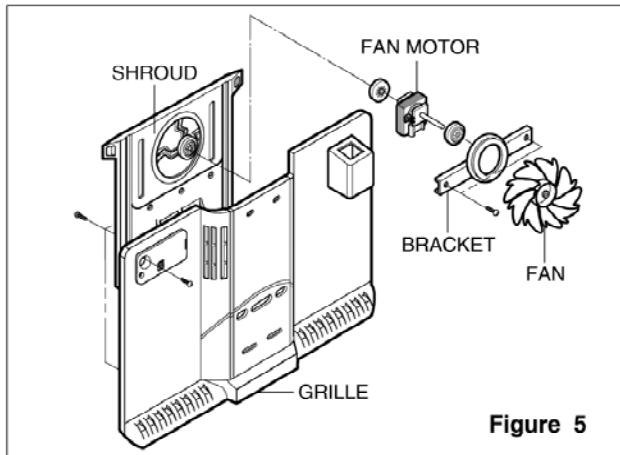

Figure 5

3-4 DEFROST CONTROL ASSEMBLY

Defrost Control assembly consists of Defrost sensor and FUSE-M.

Defrost sensor functions to defrost automatically. It is attached to metal side of the Evaporator and senses Temperature. At the temperature of 162°F(72°C), it stops the emission of heat from the Heater.

Fuse-M is a safety device for preventing over-heating of the Heater when defrosting.

1. Pull out the grille assembly. (Figure 6)
2. Separate the connector connected with the Defrost Control assembly and replace the Defrost Control assembly after cutting the Tie Wrap. (Figure 7)

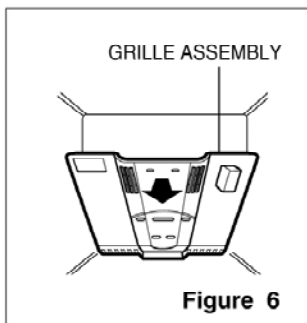

Figure 6

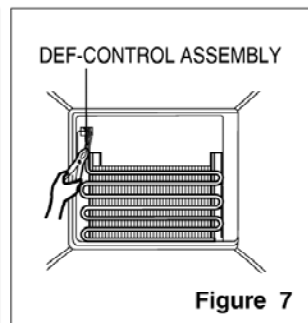

Figure 7

3-5 LAMP

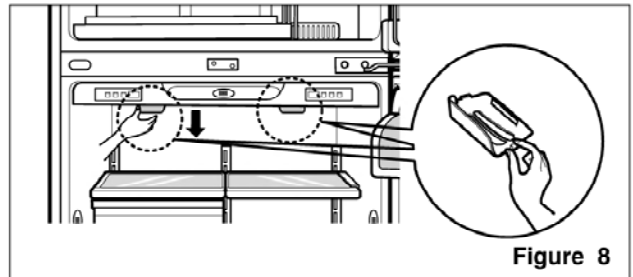

Figure 8

3-5-1 Refrigerator Compartment Lamp

1. Unplug the power cord from the outlet.
2. Remove refrigerator shelves.
3. Release the hooks on both ends of the lamp shield and pull the shield downward to remove it.
4. Turn the lamp counterclockwise.
5. Assemble in reverse order of disassembly. Replacement bulb must be the same specification as the original (Max. 60 W-2EA).

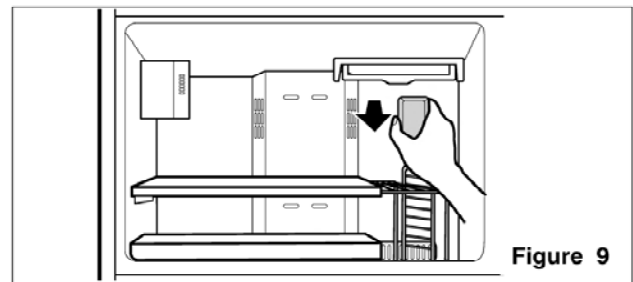

Figure 9

3-5-2 Freezer Compartment Lamp

1. Unplug refrigerator or disconnect power.
2. Reach behind light shield to remove bulb.
3. Replace bulb with a 40-watt appliance bulb.
4. Plug in refrigerator or reconnect power.

3-6 CONTROL BOX-R

1. First, remove all shelves in the refrigerator and Control Box-R by loosening 2 screws.

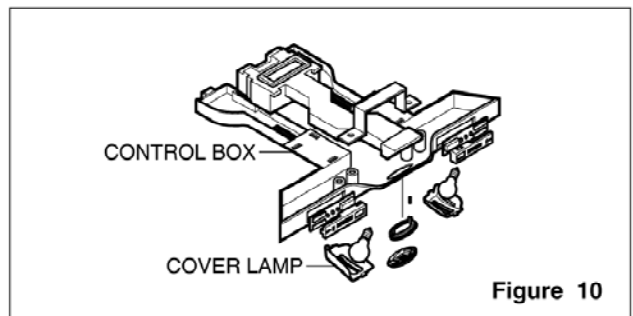

Figure 10

2. Remove the Control Box-R by pulling it downward.
3. Disconnect the lead wire on the right position and separate lamp socket, etc.

4. ADJUSTMENT

4-1 COMPRESSOR

4-1-1 Role

The compressor intakes low temperature and low pressure gas evaporated from the evaporator of the refrigerator and condenses this gas to high-temperature and high-pressure gas. It then delivers the gas to the condenser.

4-1-2 Composition

The compressor includes overload protection. The PTC starter and OLP (overload protector) are attached to the outside of the compressor. Since the compressor is manufactured to tolerances of 1 micron, and is sealed in a dust and moisture-free environment, use extreme caution when repairing it.

4-1-3 Note for Usage

- (1) Be careful not to allow over-voltage and over-current.
- (2) If compressor is dropped or handled carelessly, poor operation and noise may result.
- (3) Use proper electric components appropriate to the Compressor.
- (4) Keep Compressor dry.
If Compressor gets wet in the rain and rust forms in the pin of the Hermetic Terminal, poor operation and contact may result.
- (5) When replacing the Compressor, be careful that dust, humidity, and soldering flux don't contaminate the inside of the compressor. Dust, humidity, and solder flux contaminate the cylinder and may cause noise or even cause it to lock up.

4-2 PTC-STARTER

4-2-1 Composition of PTC-Starter

- (1) PTC (Positive Temperature Coefficient) is a no-contact semiconductor starting device which uses ceramic material consisting of $BaTiO_3$.
- (2) The higher the temperature is, the higher the resistance value. These features are used as a starting device for the Motor.

4-2-2 Role of PTC-Starter

- (1) The PTC is attached to the Hermetic Compressor and is used for starting the Motor.
- (2) The compressor is single-phase induction motor. During the starting operation, the PTC allows current flow to both the start winding and main winding.

4-2-3 PTC-Applied Circuit Diagram

● According to Starting Method for the Motor

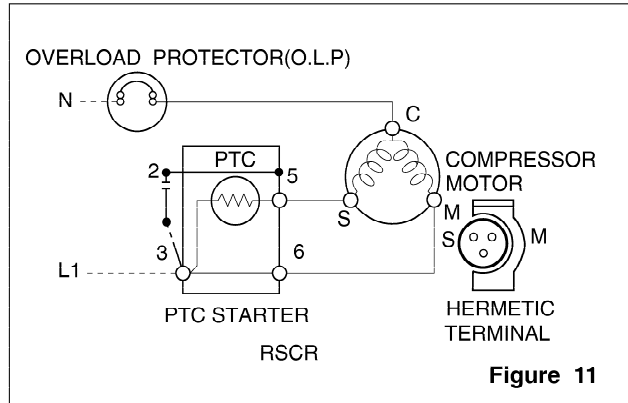

4-2-4 Motor Restarting and PTC Cooling

- (1) It requires approximately 5-minutes for the pressure to equalize before the compressor can start.
- (2) The PTC device generates heat during operation. Therefore it must be allowed to cool before the compressor can restart.

4-2-5 Relation of PTC-Starter and OLP

- (1) If the compressor attempts to restart before the PTC device is cooled, the PTC device will only allow current to flow to the main winding.
- (2) The OLP will open because of the over current condition. This same process will continue (3 to 5 times) when the compressor attempts to restart until the PTC device has cooled. The correct OLP must be properly attached to prevent damage to the compressor.

4-2-6 Note for Using the PTC-Starter

- (1) Be careful not to allow over-voltage and over-current.
- (2) Do not drop or handle carelessly.
- (3) Keep away from any liquid.
If liquid such as oil or water enters the PTC, PTC materials may fail due to breakdown of their insulating capabilities.
- (4) If the exterior of the PTC is damaged, the resistance value may be altered. This can cause damage to the compressor and result in a no start condition or hard to start condition.
- (5) Always use the PTC designed for the compressor and make sure it is properly attached to the compressor.

4-3 OLP (OVERLOAD PROTECTOR)

4-3-1 Definition of OLP

- (1) OLP (OVERLOAD PROTECTOR) is attached to the Compressor and protects the Motor by opening the circuit to the Motor if the temperature rises and activating the bimetal spring in the OLP.
- (2) When high current flows to the Compressor motor, the Bimetal works by heating the heater inside the OLP. The OLP protects the motor by cutting off the current flowing to the Compressor Motor.

4-3-2 Role of the OLP

- (1) The OLP is attached to the Hermetic Compressor used for the Refrigerator. It prevents the main Coil from being started in the Compressor.
- (2) For normal operation of the OLP, do not turn the Adjust Screw of the OLP in any way.

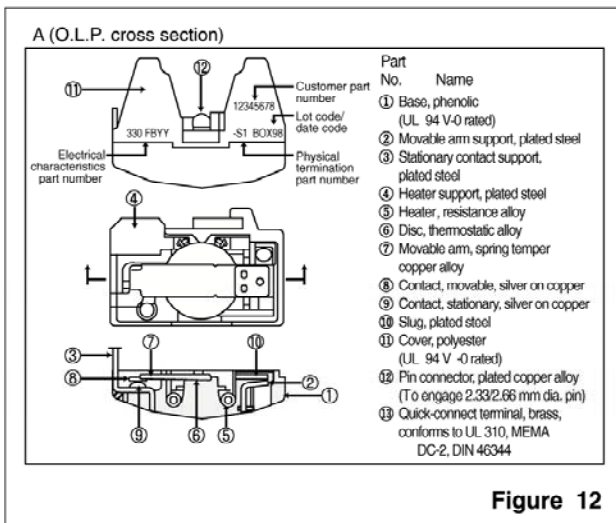
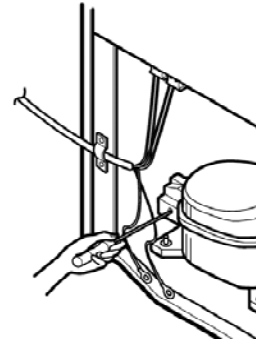

Figure 12

4-4 TO REMOVE THE COVER PTC



- 1) Remove the Cover Back M/C.
- (2) Remove the screw on Cover PTC.



- (3) Remove two Housings on upper part of Cover PTC.
- (4) Take out the cover PTC from upper to lower position like ①.

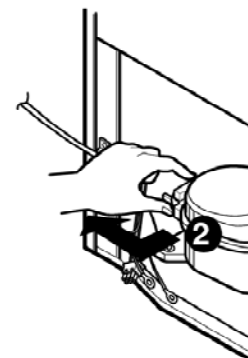

- (5) Turn 45° in the direction of ② and take it out.
- (6) Assembly in reverse order of disassembly.

5. CIRCUIT DIAGRAM

SEARS BEST MODEL

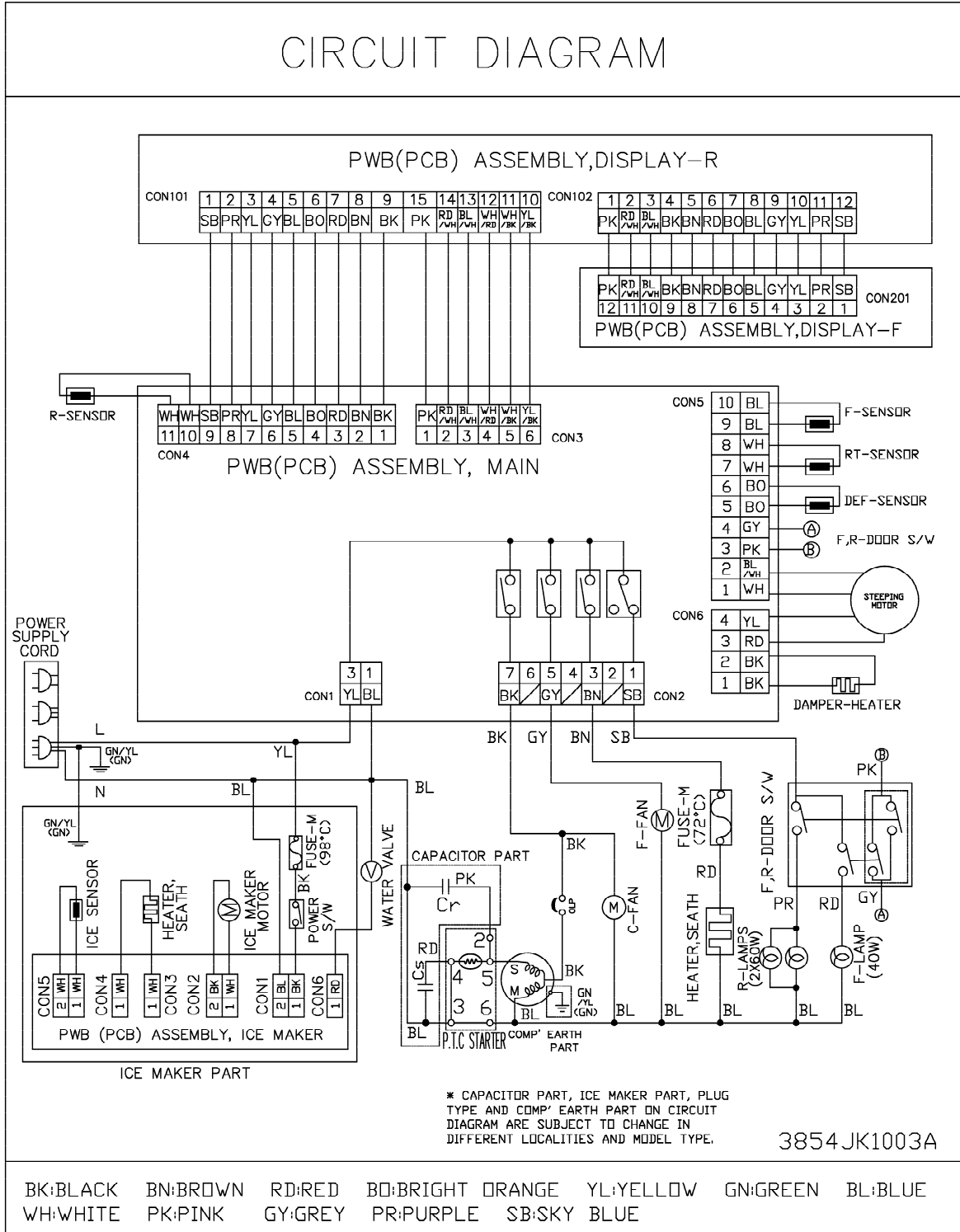

SEARS BETTER MODEL

CIRCUIT DIAGRAM

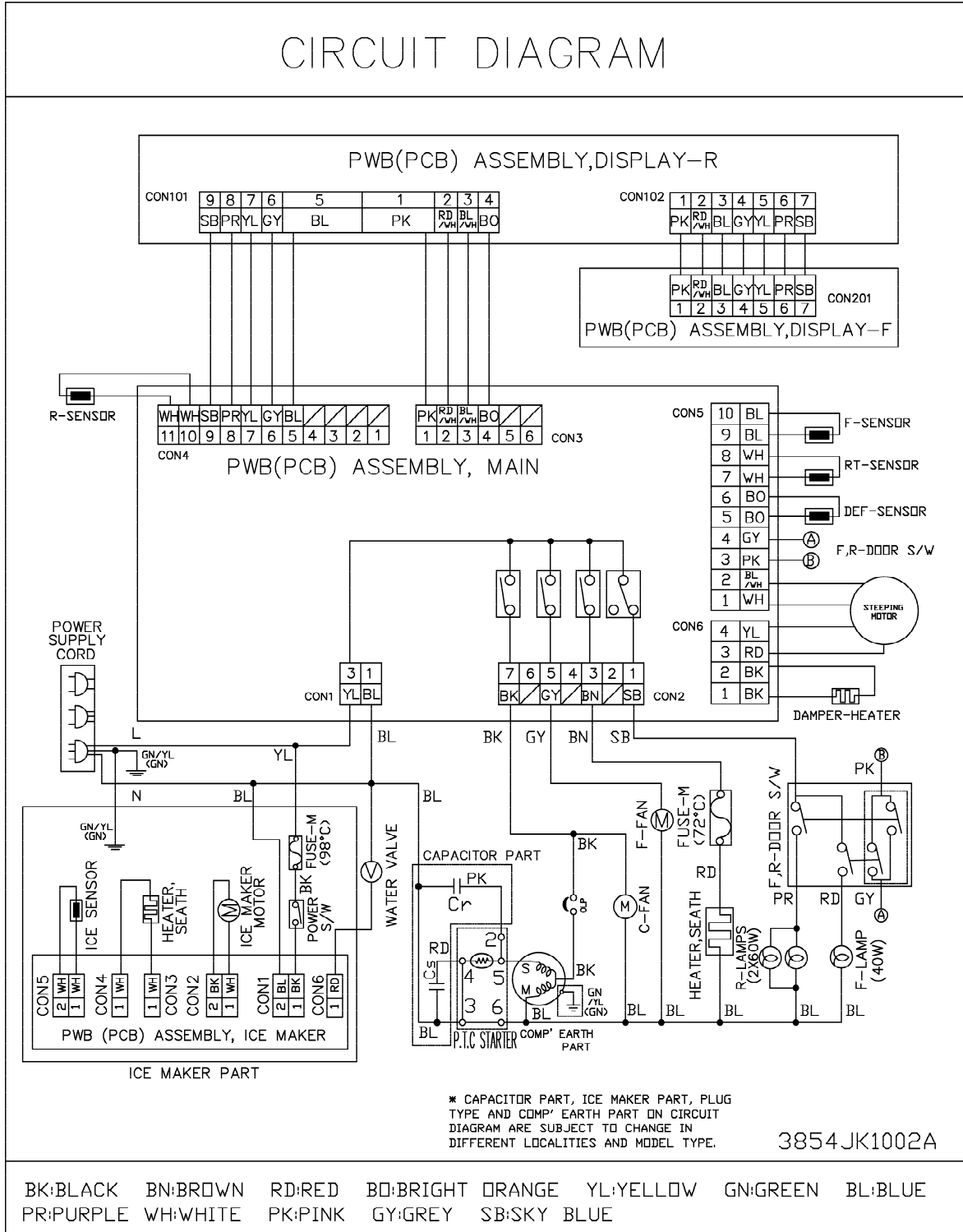

6. TROUBLESHOOTING

6-1 COMPRESSOR AND ELECTRIC COMPONENTS

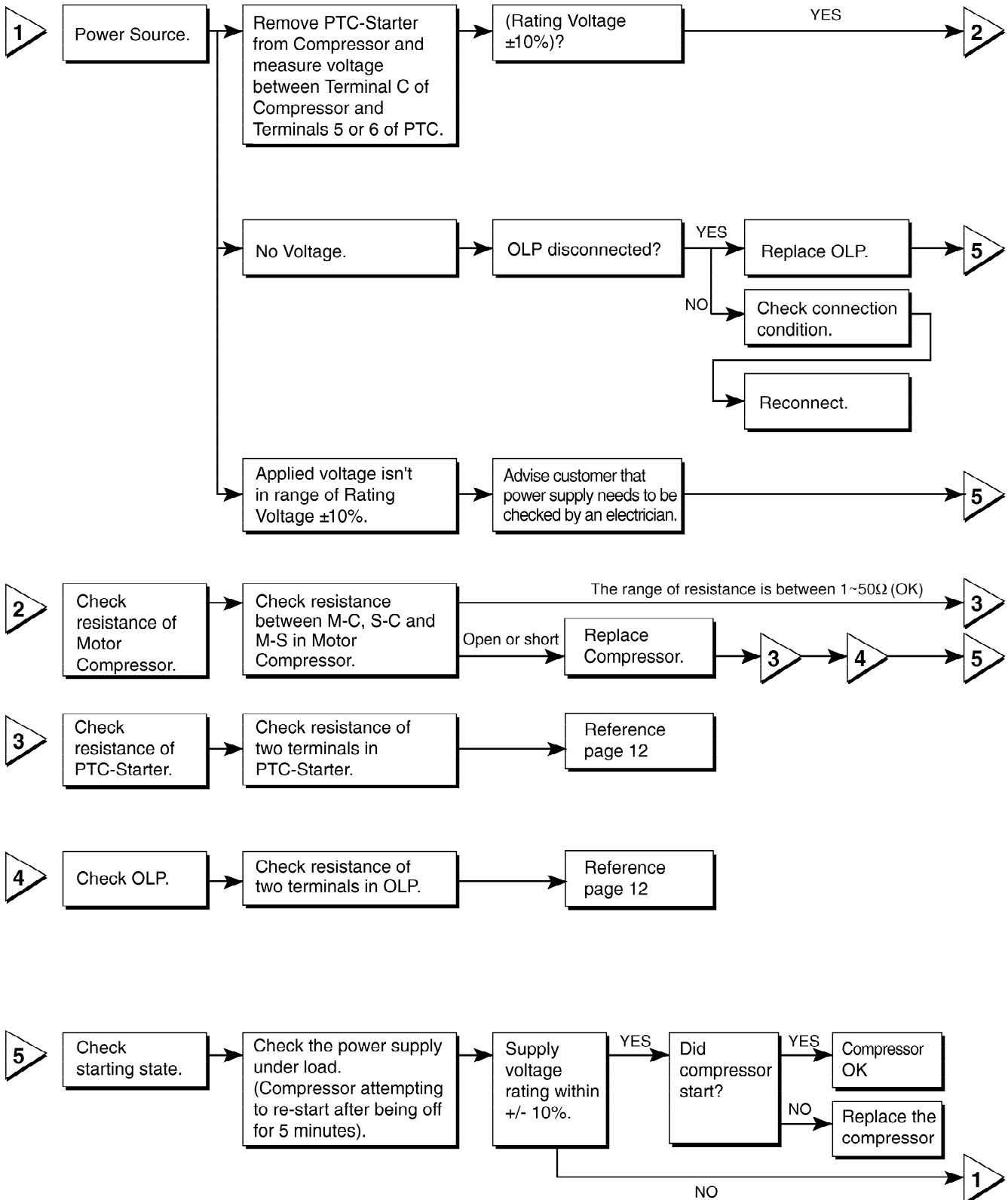

6-2 PTC AND OLP

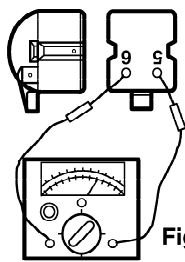
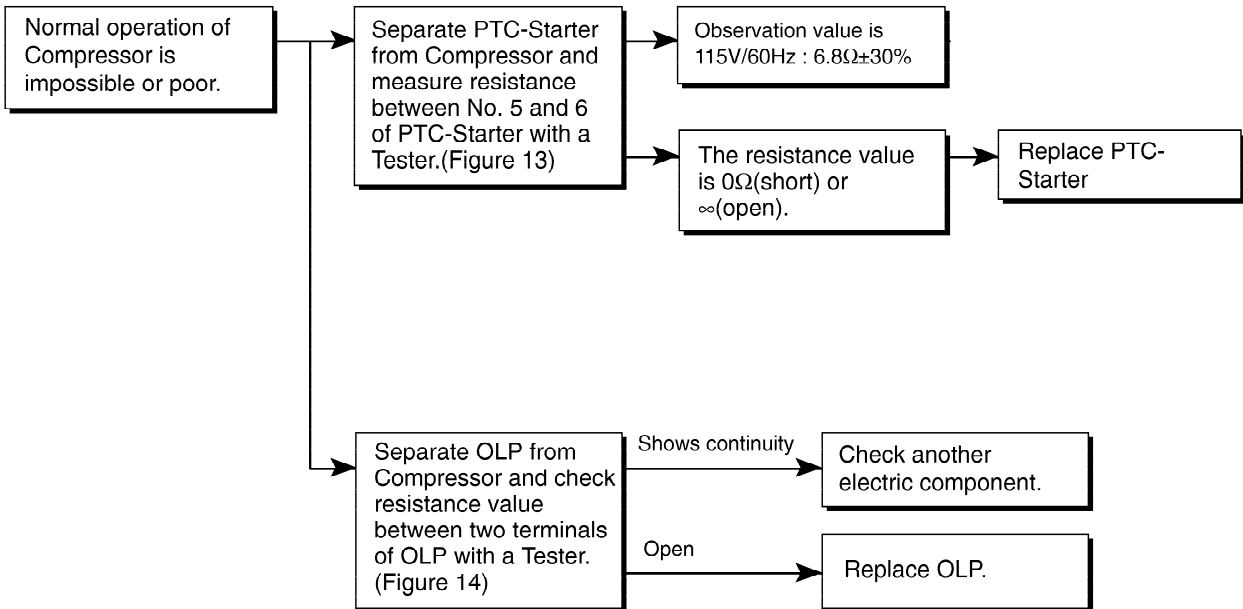

Figure 13

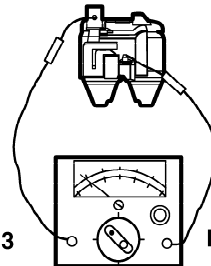
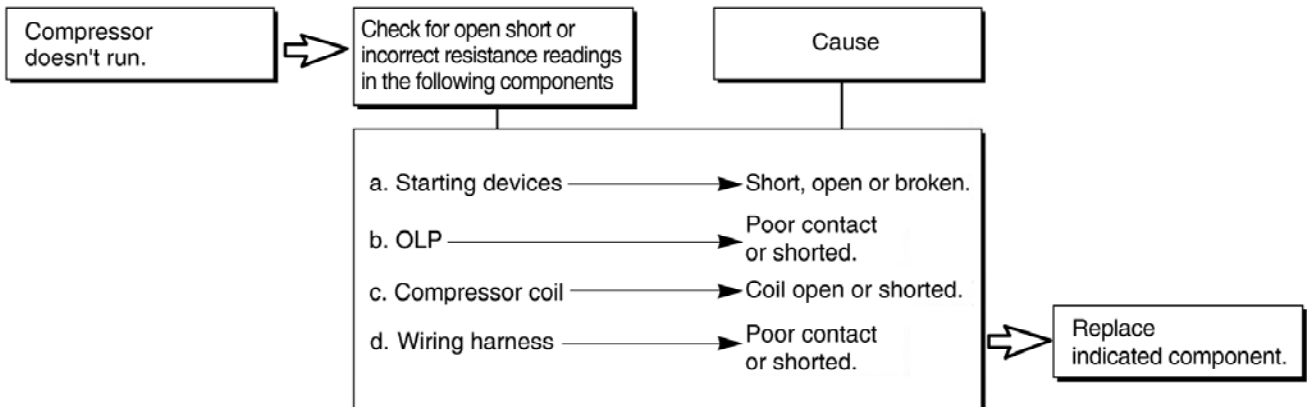

Figure 14

6-3 OTHER ELECTRIC COMPONENTS

▼ Not cooling at all



▼ Poor cooling performance

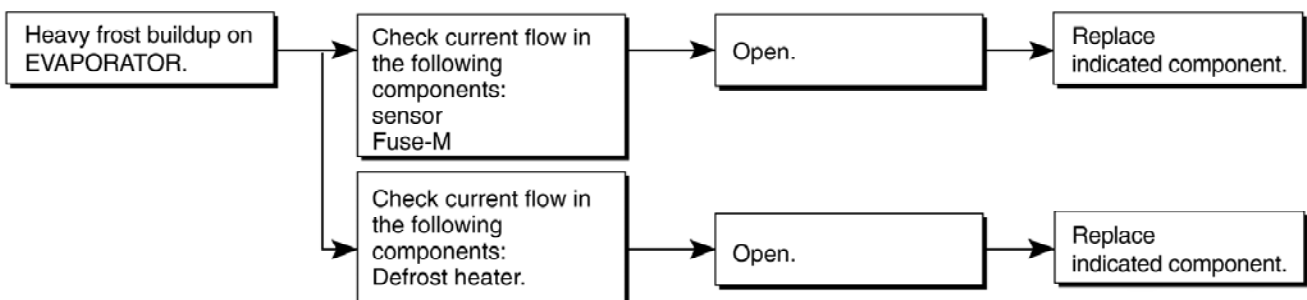
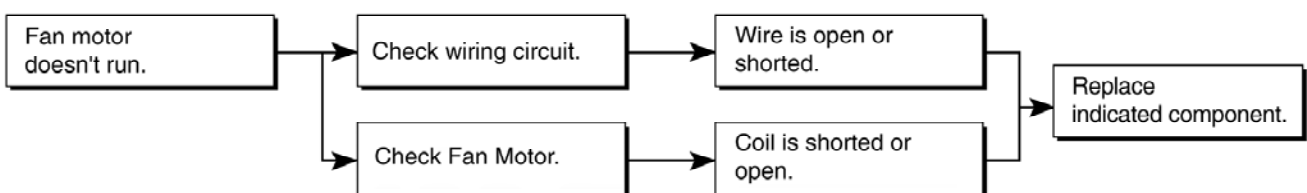
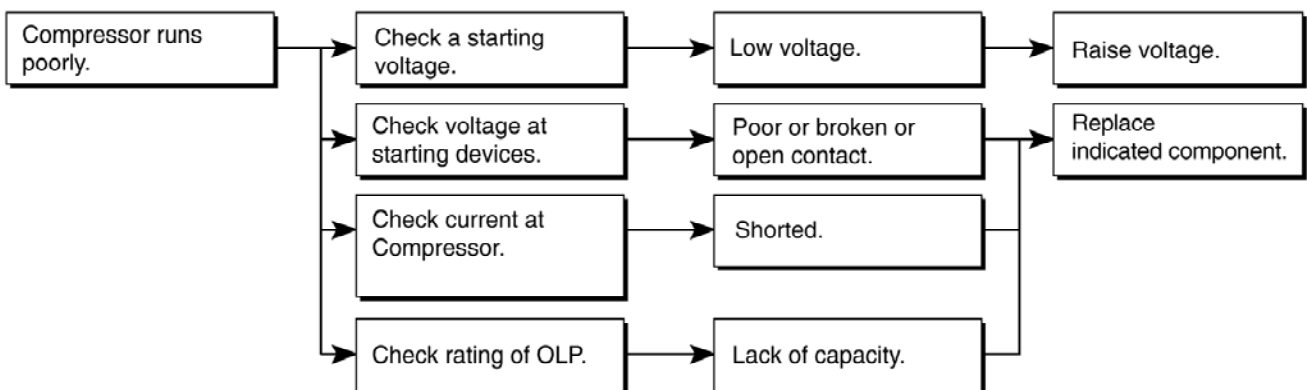

6-4 SERVICE DIAGNOSIS CHART

COMPLAINT	POINTS TO BE CHECKED	REMEDY
No Cooling.	<ul style="list-style-type: none"> • Is the power cord unplugged from the outlet? • Check if the power S/W is set to OFF. • Check if the fuse of the power S/W is shorted. • Measure the voltage of the power outlet. 	<ul style="list-style-type: none"> • Plug into the outlet. • Set the switch to ON. • Replace the fuse. • If the voltage is low, correct the wiring.
Cools poorly.	<ul style="list-style-type: none"> • Check if the unit is placed too close to the wall. • Check if the unit is placed too close to the stove, gas cooker and direct sunlight. • Is the ambient temperature too high or the room door closed? • Check if food put in the refrigerator is hot. • Did you open the door of the unit too often or check if the door is sealed properly? • Check if the Control is set to "Warm position". 	<ul style="list-style-type: none"> • Place the unit about 10 cm (4 inches) from the wall. • Place the unit away from these heat sources. • Lower the ambient temperature. • Put in foods after they have cooled down. • Don't open the door too often and close it firmly. • Set the control to "Recommended-position".
Foods in the Refrigerator are frozen.	<ul style="list-style-type: none"> • Is food placed in the cooling air outlet? • Check if the control is set to "colder-position". • Is the ambient temperature below 41°F(5°C)? 	<ul style="list-style-type: none"> • Place foods in the high-temperature section. (front part) • Set the control to "Recommended-position". • Set the control to "Warm-position".
Dew or ice forms inside the unit.	<ul style="list-style-type: none"> • Is liquid food sealed? • Check if food put in the refrigerator is hot. • Did you open the door of the unit too often or check if the door is sealed properly? 	<ul style="list-style-type: none"> • Seal liquid foods with wrap. • Put in foods after they have cooled down. • Don't open the door too often and close it firmly.
Dew forms in the Exterior Case.	<ul style="list-style-type: none"> • Check if the ambient temperature and humidity of the surrounding air are high. • Is there a gap in the door gasket? 	<ul style="list-style-type: none"> • Wipe dew with a dry cloth. Dew will disappear in low temperature and humidity. • Fill up the gap.
There is abnormal noise.	<ul style="list-style-type: none"> • Is the unit positioned in a firm and even place? • Are any unnecessary objects placed in the back side of the unit? • Check if the Drip Tray is not firmly fixed. • Check if the cover of the compressor enclosure in the lower front side is taken out. 	<ul style="list-style-type: none"> • Adjust the Adjust Screw, and position in a firm place. • Remove the objects. • Fix Drip Tray firmly in the original position. • Place the cover in its original position.
Door does not close well.	<ul style="list-style-type: none"> • Check if the door gasket is dirty with an item like juice. • Is the refrigerator level? • Is there too much food in the refrigerator? 	<ul style="list-style-type: none"> • Clean a door gasket. • Position in the firm place and level the Adjust Screw. • Make sure food stored in shelves does not prevent the door from closing.
Ice and foods smell unpleasant	<ul style="list-style-type: none"> • Check if the inside of the unit is dirty. • Are foods with a strong odor unwrapped? • The unit smells of plastic. 	<ul style="list-style-type: none"> • Clean the inside of the unit. • Wrap foods that have a strong odor. • New products smell of plastic, but this will go away after 1-2 weeks.

● Other possible problems:

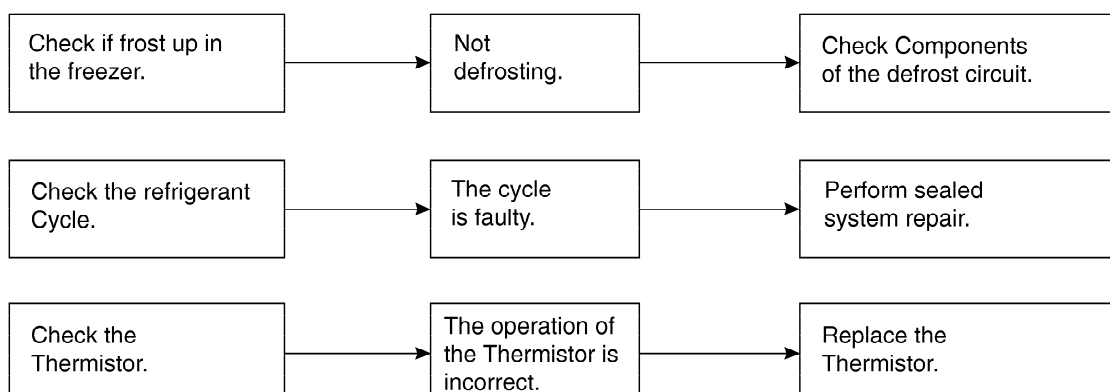

6-5 REFRIGERANT CYCLE

▼ Troubleshooting Chart

CAUSE		STATE OF THE UNIT	STATE OF THE EVAPORATOR	TEMPERATURE OF THE COMPRESSOR	REMARKS
LEAKAGE	PARTIAL LEAKAGE	Freezer compartment and Refrigerator don't cool normally.	Low flowing sound of Refrigerant is heard and frost forms in inlet only.	A little higher than ambient temperature.	<ul style="list-style-type: none"> Refrigerant level is low due to a leak. Normal cooling is possible by restoring the normal amount of refrigerant.
	WHOLE LEAKAGE	Freezer compartment and Refrigerator don't cool normally.	Flowing sound of refrigerant is not heard and frost isn't formed.	Equal to ambient temperature.	<ul style="list-style-type: none"> No discharging of Refrigerant. Normal cooling is possible by restoring the normal amount of refrigerant.
RESTRICTED BY DUST	PARTIAL RESTRICTION	Freezer compartment and Refrigerator don't cool normally.	Flowing sound of refrigerant is heard and frost forms in inlet only.	A little higher than ambient temperature.	<ul style="list-style-type: none"> Normal discharging of the refrigerant. The capillary tube is faulty.
	WHOLE RESTRICTION	Freezer compartment and Refrigerator don't cool.	Flowing sound of refrigerant is not heard and frost isn't formed.	Equal to ambient temperature.	<ul style="list-style-type: none"> Normal discharging of the Refrigerant.
MOISTURE RESTRICTION		Cooling operation stops periodically.	Flowing sound of refrigerant is not heard and frost melts.	Lower than ambient temperature.	<ul style="list-style-type: none"> Cooling operation restarts when heating the inlet of the capillary tube.
DEFECTIVE COMPRESSION	COMP-RESSION	Freezer and Refrigerator don't cool.	Low flowing sound of refrigerant is heard and frost forms in inlet only.	A little higher ambient temperature.	<ul style="list-style-type: none"> Low pressure at high side of compressor due to low refrigerant level.
	NO COMP-RESSION	No compressing operation.	Flowing sound of refrigerant is not heard and there is no frost.	Equal to ambient temperature.	<ul style="list-style-type: none"> No pressure in the high pressure part of the compressor.

6-5-1 SEALED SYSTEM DIAGNOSIS

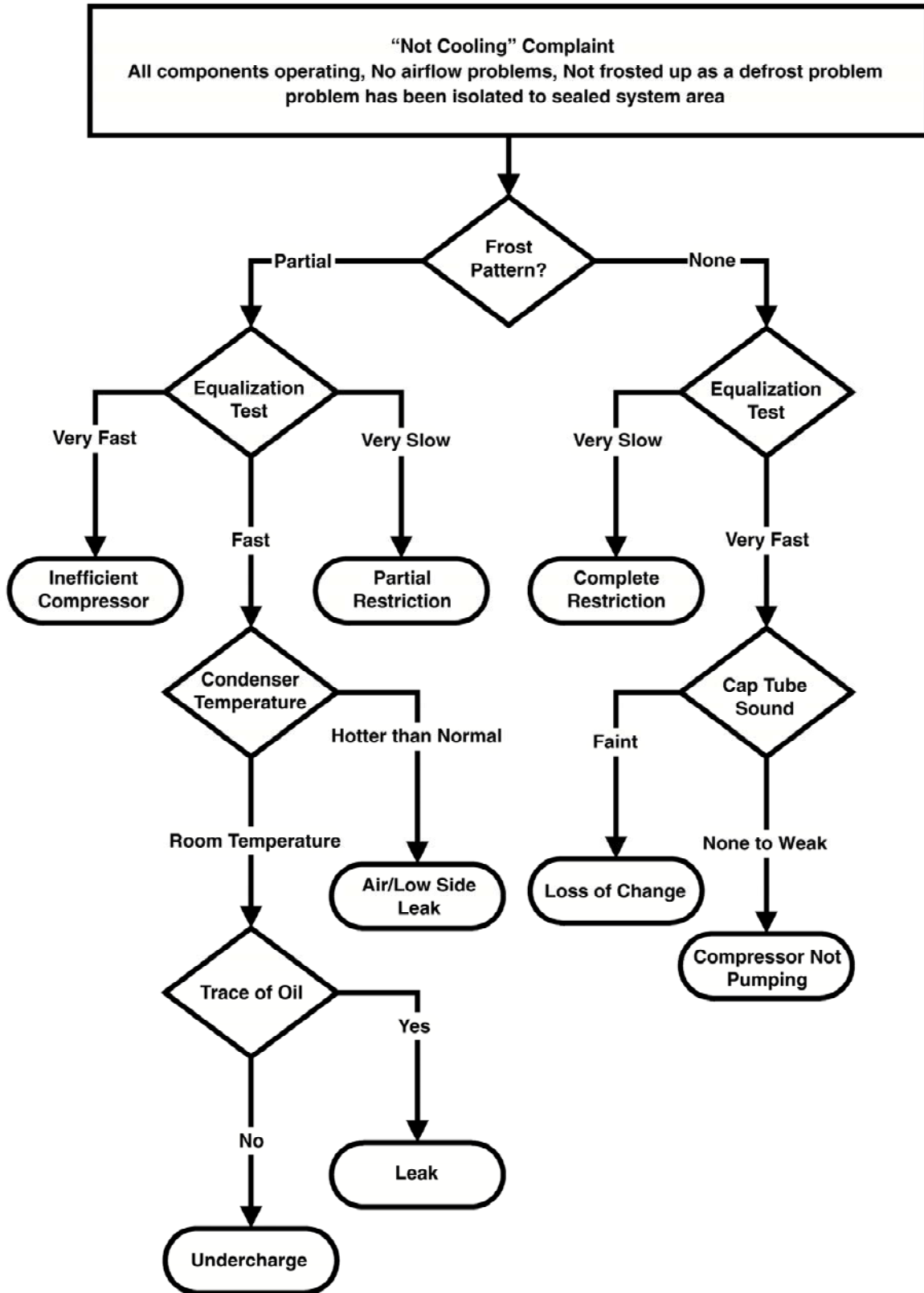

(The equalization test is trying to restart a compressor using a start kit after it has been operating.)

7. OPERATION PRINCIPLE AND REPAIR METHOD OF ICE MAKER

7-1 OPERATION PRINCIPLE

7-1-1 Operation Principle of Ice Maker

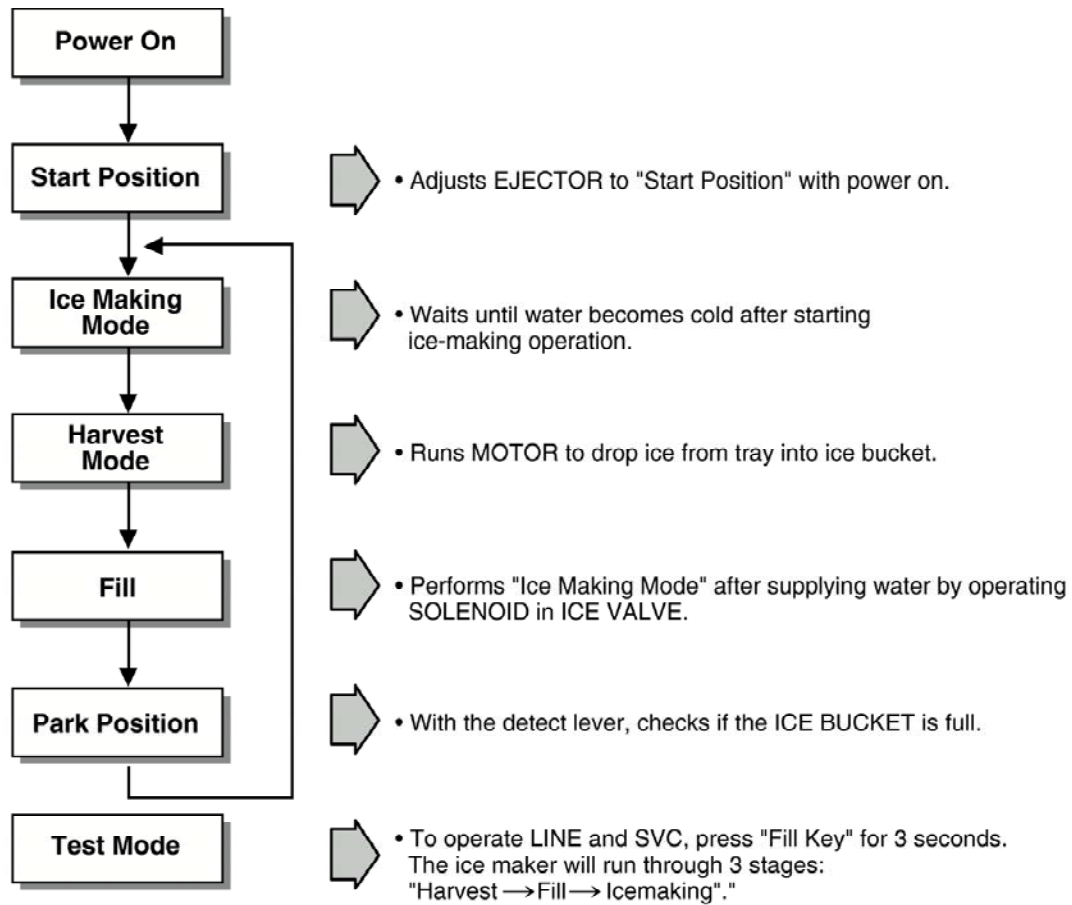

1. Turning the ice-making stop switch off (O) stops the ice-making function.
2. Setting the ice-maker switch to OFF and then turning it back on will reset the icemaker control.

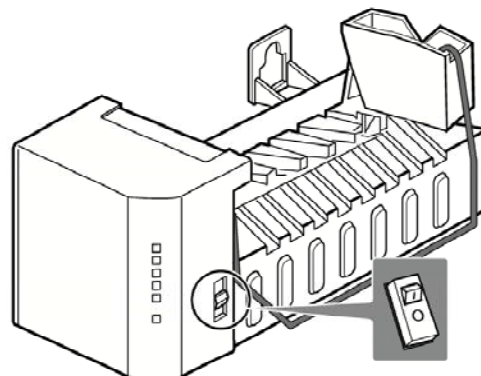

7-2 CONTROL METHOD ACCORDING TO FUNCTIONS

7-2-1 Start Position

1. After POWER OFF or Power Cut, check EJECTOR's position with MICOM initialization to restart.
2. Control Method to check if it's in place:
 - (1) EJECTOR is in place,
 - The ejector must be in the park position before a new cycle can be initiated.
 - (2) EJECTOR isn't in place:
 - A. If there is no ice formed in the ice maker, it should take approximately 2 minutes for the ejector blades to cycle through the harvest mode and return to the park position.
 - B. If there is ice formed in the ice maker, it can take up to 18 minutes for the ejector blades to cycle through the harvest mode and return to the park position.

7-2-2 Ice Making Mode

1. The Ice Making Mode starts once the ejector is in the park position and the ice maker mold is filled with water.
2. The Ice Making Mode is terminated when the ice maker sensor reaches 19°F(-7°C). This may take between 1 and 4 hours.

7-2-3 Harvest Mode

1. The Harvest mode is initiated when the temperature is satisfied with the shut-off arm in the down position.
2. Once the Harvest mode is initiated, the heater is operated for 30 seconds.
3. After 30 seconds, the ejector blades are operated.
4. Once the ejector blades have reached the park position water fill will be initiated.

NOTE : If no movement is detected from the shut-off arm (detect lever), a Harvest mode will be attempted every 2 hours.

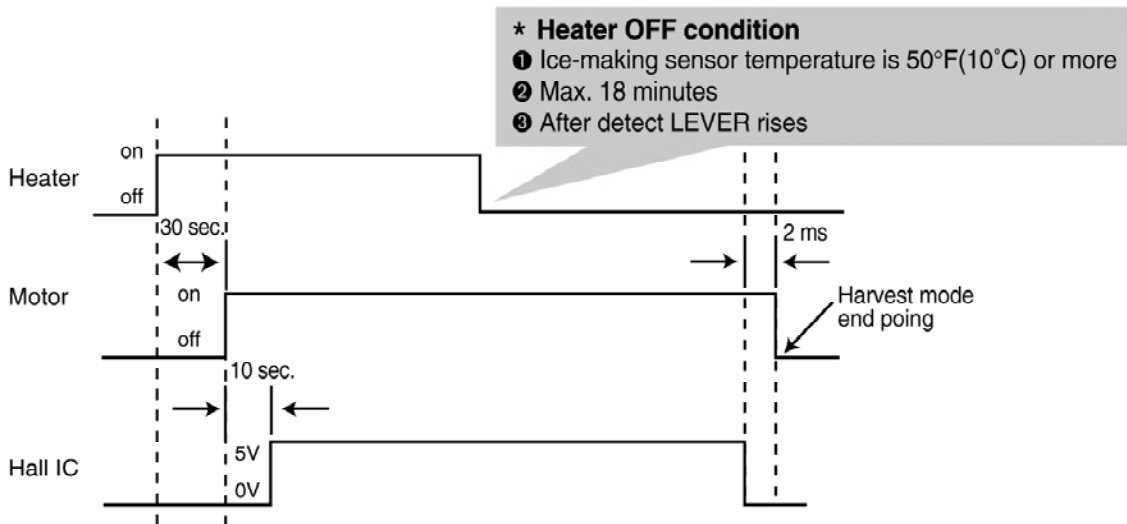





<fig1. Harvest mode process>

7-2-4 Fill / Park Position

1. Once a normal harvest mode has been completed, the water solenoid will be activated.
2. The amount of water is adjusted by pressing the water supply control S/W. This changes the time allowed for fill as illustrated in the chart.

<Water supply amount TABLE>

STAGE	TIME TO SUPPLY	INDICATIONS	REMARKS
1	6 sec.		The water amount will vary depending on the water control S/W setting, as well as the water pressure of the connected water line.
2	7 sec.		
3	8 sec.		
4	9 sec.		
5	10 sec.		



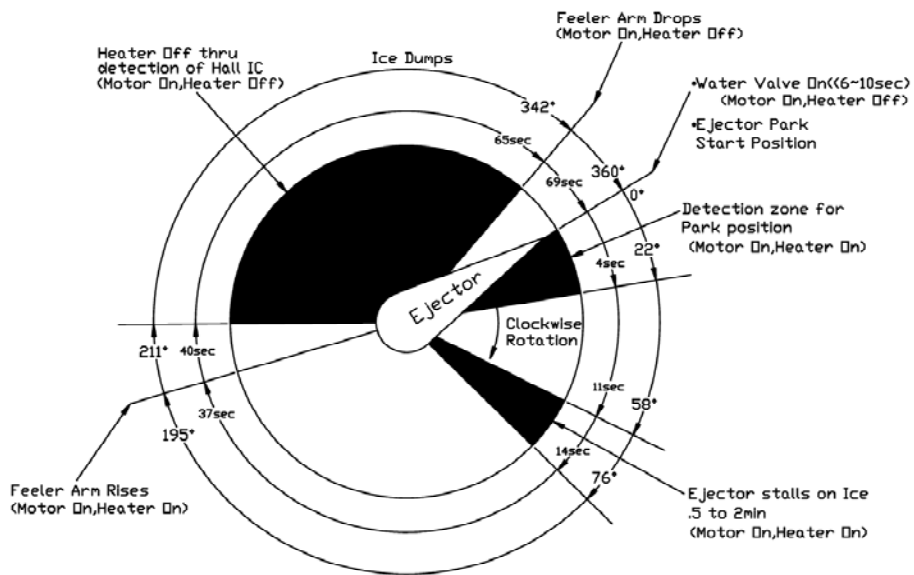

NOTE : Below is an example used by another vendor as an explanation of what is taking place.



7-2-5 Function TEST



1. This is a compulsory operation for TEST, SVC, cleaning, etc. It is operated by pressing the water supply control KEY for 3 seconds.
2. It operates in the Ice-Making mode, but not in the Ice-Removing mode or water supply process. (If there is an ERROR, it can only be checked in the TEST mode.)
3. If the water supply control KEY is pressed for 3 seconds in the Ice-Making mode (no matter what condition the Ice-Making tray is in) the Ice-Removing operation starts immediately. Even if water is not yet frozen, additional water will be added. If the control doesn't operate normally in the TEST mode, check and repair as needed.
4. After water is supplied, the normal CYCLE is followed: ice making → Harvest → Fill → Park position.
5. When Stage 5 is completed in the TEST mode, minimize MICOM in 5 seconds, the time needed to supply water resets to the previous status in the TEST mode.

<Diagnosis TABLE>

STAGE	ITEMS	INDICATOR	REMARKS
1	HEATER		Five seconds after heater starts, heater will go off if temperature recorded by sensor is 50°F(10°C) or lever is in up position.
2	MOTOR		Five seconds after heater starts, you can confirm that motor is moving.
3	HALL IC (detection of position) I		You can confirm hall ic detection of position.
4	VALVE		Two seconds after detection of initial position, you can confirm that valve is on.
5	HALL IC II (detection of full ice bucket)		You can check whether hall is sensing full ice bucket condition.(If there is a full-filled error, the fifth LED is not on.)
6	Reset	Mark previous status on TEST mode	Five seconds after fifth stage is completed, reset at initial status.

7-3 DEFECT DIAGNOSIS FUNCTION

7-3-1 ERROR CODES shown on Ice Maker water supply control panel

NO	DIVISION	INDICATOR	CONTENTS	REMARKS
1	Normal	Mark time to supply	None	Display switch operates properly
2	Ice-Making Sensor malfunction		Open or short-circuited wire	Make sure that the wire on each sensor is connected.
3	Ice Maker Kit malfunction		When ejector blades don't reach park position over 18 minutes since Harvest Mode starts.	Check of HALL IC/MOTOR/ HEATER/RELAY

ERROR indicators in table can be checked only in TEST mode.

8. DESCRIPTION OF FUNCTION & CIRCUIT OF MICOM

8-1 FUNCTION

8-1-1 Function

- When the appliance is plugged in, it is set to "37 °F" for the Refrigerator and "0 °F" for the Freezer (set to "4" for Refrigerator and "4" for Freezer).
You can adjust the Refrigerator and the Freezer control temperature by pressing the COLDER button or the COLD button.
- When the power is initially applied or restored after a power failure, it is automatically reset to "37 °F" and "0 °F" (set to "4" and "4").

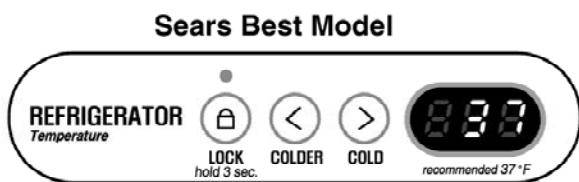

Control range : 32°F ~ 47°F
0°C ~ 8°C

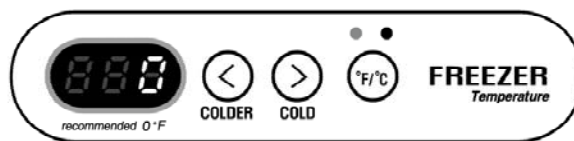

Control range : -6°F ~ 8°F
-21°C ~ -13°C

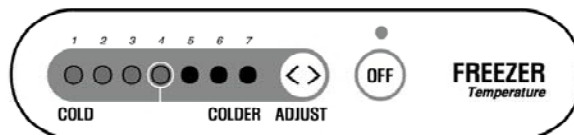
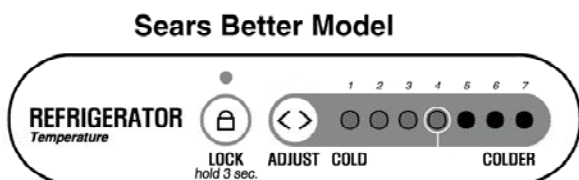

8-1-2 How to Change the Temperature Mode to °F / °C

- The setting temperature mode can be changed to °F / °C by pressing the " °F / °C " button.
- The initial setting is on °F. When the mode is changed the LED lights come on.

8-1-3 Key Lock

- The key pads can be locked by pressing and holding the KEY LOCK button for 3 seconds.
- The lock light will be displayed and the key pads will be inoperable.
- Pressing and holding the KEY LOCK button for 3 seconds will reactivate the key pads.

8-1-4 OFF Function

- To turn off the Best model, press and hold the °F/°C button for 3 seconds. To turn off the Better model, press and hold the OFF key for 3 seconds.
- In the Off mode, the Best model will display OFF in the control panel. The OFF light will be displayed on the Better model.
- To cancel the OFF function, press the same keys and hold for 3 seconds.

8-1-5 Alarm for Open Door

1. This feature sounds a buzzer when the freezer or refrigerator door is not closed within 1 minute after it is opened.
2. One minute after the door is opened, the buzzer sounds three times each for 0.5 seconds. These tones repeat every 30 seconds.
3. The alarm is cancelled when the freezer or the refrigerator is closed while the buzzer sounds.

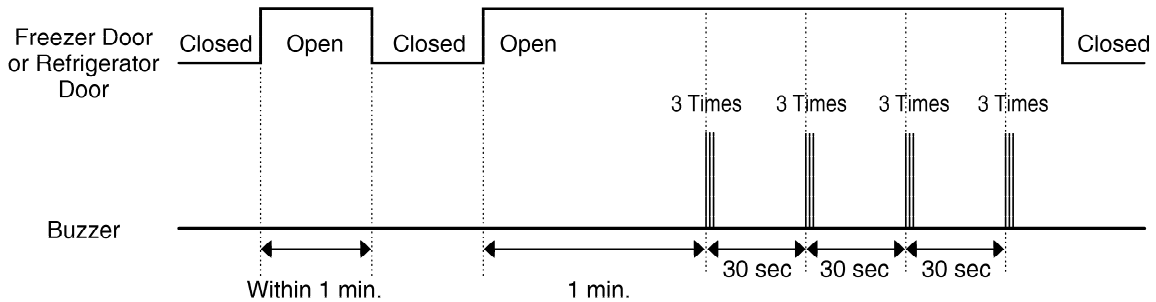

8-1-6 Buzzer Sound

When the button on the front Display is pushed, a "Ding~" sound is produced.

8-1-7 Defrost Cycle

1. A defrost cycle will be initiated after 4 hours of accumulated compressor run time after the initial power up or a power failure.
2. After the initial defrost, the defrost cycle is initiated after 7 hours of accumulated compressor run time.
3. The defrost cycle will be terminated once the defrost sensor reaches 50°F(10°C).

8-1-8 Electrical Parts operation order

Electrical parts such as COMP, defrost heater, freezer FAN, etc. operate in the following order to prevent noise and parts damage. Several parts are started at the same time at initial power on or TEST mode is completed and are turned off together.

OPERATION		ORDER				
Initial power on	Temperature of Defrost Sensor is 113°F(45°C) or more (when unit is newly purchased or when moved)	POWER ON	in 0.5 sec →	COMP ON	in 0.5 sec →	Freezer FAN ON
	Temperature of defrost sensor is lower than 113°F(45°C) (when power cuts, SVC)	POWER ON	in 0.5 sec →	Defrost heater ON	in 10 sec →	Defrost heater OFF
		in 0.5 sec →	COMP ON	in 0.5 sec →	Freezer FAN ON	
	Reset to normal operation from TEST MODE	Total load OFF	in 7 min →	COMP ON	in 0.5 sec →	Freezer FAN ON

8-1-9 Defect Diagnosis Function

1. Error codes will be displayed when defect occurs which can affect product performance.
2. When a defect occurs, the buttons will not operate; but the tones such as "ding" will sound.
3. When error code is resolved, the refrigerator will restart normally (Micom will be reset).
4. The error code shows on the refrigerator DISPLAY as temperature LED, and the other LED turns off.

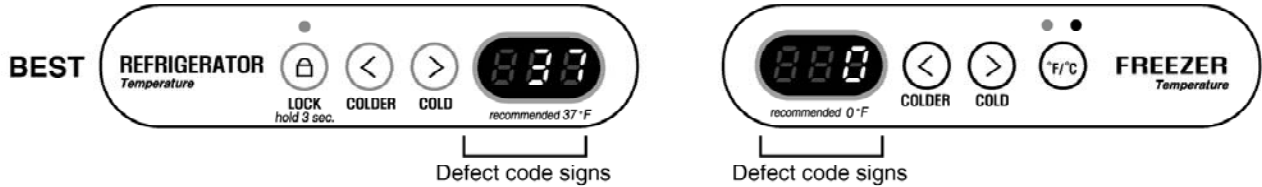

-Show ERROR CODE on Refrigerator Temperature Panel and Freezer Temperature panel.

NO	ITEM	ERROR CODE		CONTENTS	REMARKS
		REF. TEMP. PANEL	FRZ. TEMP. PANEL		
1	Freezer sensor malfunctions	Er	F5	Open or short-circuited wire	*Inspect connecting wires on each sensor
2	Refrigerator sensor malfunctions	Er	r5	Open or short-circuited wire	
3	Defrost sensor malfunctions	Er	d5	Open or short-circuited wire	
4	Room Temperature sensor malfunctions	On LED CHECK mode ERROR CODE sign		Open or short-circuited wire	
		Er	r7		
5	Defrosting malfunctions	Er	dH	2 hours after defrosting starts, the sensor is not above 50°F(10°C)	Temperature fuse open, Heater open, Drain is clogged, Heater starts but relay malfunctions.

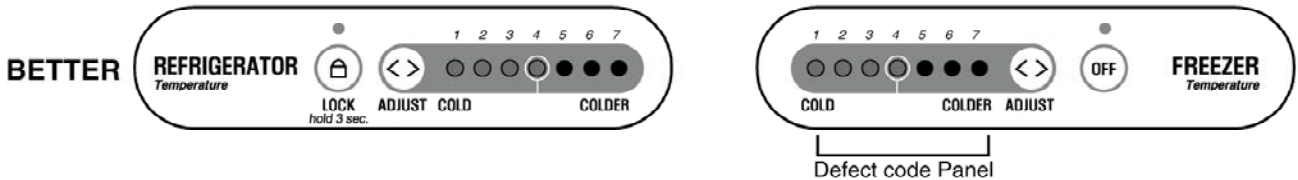

-Show ERROR CODE on Freezer Temperature panel.

○ :ON ● :OFF

NO	ITEM	DEFECT SIGNS							CONTENTS	REMARKS
		F1	F2	F3	F4	F5	F6	F7		
1	Freezer sensor malfunctions	●	○	○	○	○	○	○	Open or short-circuited wire	*Inspect connecting wires on each sensor
2	Refrigerator sensor malfunctions	○	●	○	○	○	○	○	Open or short-circuited wire	
3	Defrost sensor malfunctions	○	○	●	○	○	○	○	Open or short-circuited wire	
4	Room Temperature sensor malfunctions	On LED CHECK mode							Open or short-circuited wire	
		●	○	●	○	○	○	○		
5	Defrosting malfunctions	●	●	●	●	○	○	○	2 hours after defrosting starts, the sensor is not above 50°F(10°C)	Temperature fuse open, Heater open, Drain is clogged, Heater starts but relay malfunctions.

8-1-10 TEST Mode

1. The Test mode allows checking the PCB and the function of the product as well as finding out the Defective part in case of an error.
2. The test button is on the main PCB of the refrigerator (Test S/W). The test mode will be cleared in 2 hours regardless of the type of test mode.
3. While in the test mode, the function control button will not operate, though the recognition tone (beep~) sounds.
4. After exiting the test mode, be sure to reset by unplugging and then plugging in the appliance.
5. If an error (such as a sensor failure) is detected while in the test mode, the test mode is deactivated and the error code is displayed.
6. While an error code is displayed, the test mode cannot be activated even if the test button is pushed.

MODE	MANIPULATION	CONTENTS	REMARKS
TEST1	Push the test button once.	1. Continuous operation of the COMP 2. Continuous operation of the freezer fan 3. STEPPING DAMPER OPEN 4. Defrost heater OFF 5. Every DISPLAY LED ON	
TEST2	Push the test button once while in TEST MODE 1.	1. COMP OFF 2. Freezer FAN OFF 3. STEPPING DAMPER CLOSE 4. Defrost heater ON 5. DISPLAY LED shows "222"(BEST Models) Only LEDs number 2 are on (BETTER Models)	Reset if the temperature of the Defrost sensor is 50°F(10°C) or more.
Reset	Push the test button once while in TEST MODE 2.	Reset to the default setting	The compressor will Start after 7-minute delay.

8-2 PCB FUNCTION

8-2-1 Power Circuit

1. Power is supplied to the control board at pins 1 and 3 of connector #1.

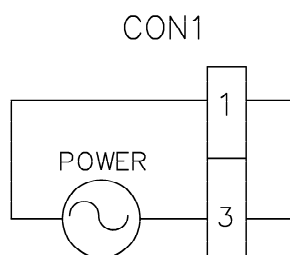

8-2-2 Load / Buzzer Drive & Open Door Detection Circuit

1. Load Drive Condition Check

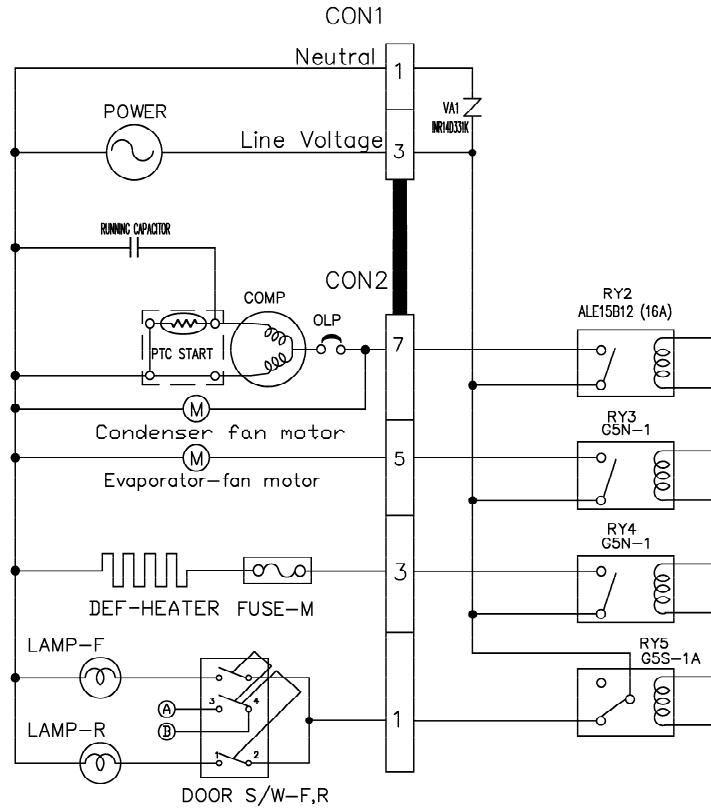

To measure outputs of the control board, check voltages between the pins for the following components:

Circuit	Pin Number	Pin Number	Output Voltage
Compressor	Con2 pin7	Con1 pin1	115 VAC
Condenser fan	Con2 pin7	Con1 pin1	115 VAC
Evaporator fan	Con2 pin5	Con1 pin1	115 VAC
Defrost heater	Con2 pin3	Con1 pin1	115 VAC
F,R-lamp	Con2 pin1	Con1 pin1	115 VAC

NOTE: When the door of the freezer/refrigerator is left open for 7 minutes or longer, the lamp of the freezer/refrigerator turns off automatically.

2. Open Door Circuit (Door Monitor Circuit)

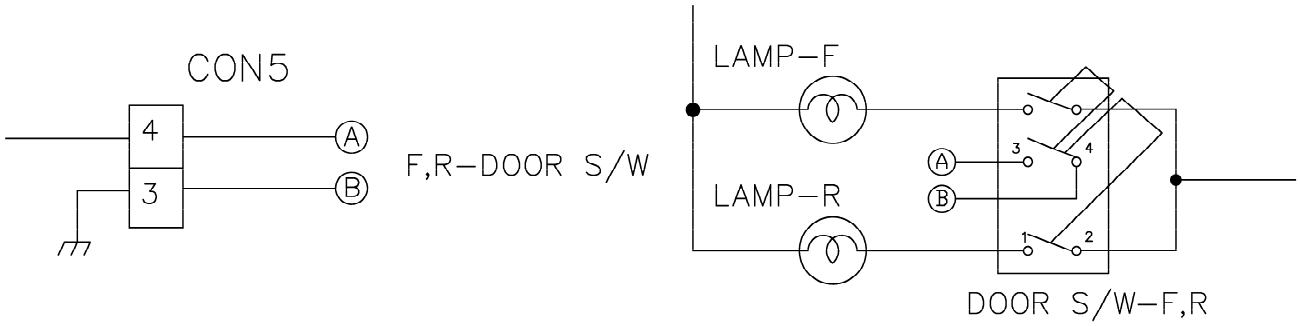

Freezer or Refrigerator	Measurement between pins 4 and 3 at Con 5
Both Closed	0 volts
One door open	5 volts

8-2-3 Temperature Sensor Circuit

Voltage supplied to each sensor will range between 0.5 volts $-22^{\circ}\text{F}(-30^{\circ}\text{C})$ and 4.5 volts $122^{\circ}\text{F}(50^{\circ}\text{C})$ depending upon the temperature in the compartments. A measurement of 0 volts indicates a short in the sensor circuit. A measurement of 5.0 volts indicates an open in the sensor circuit.

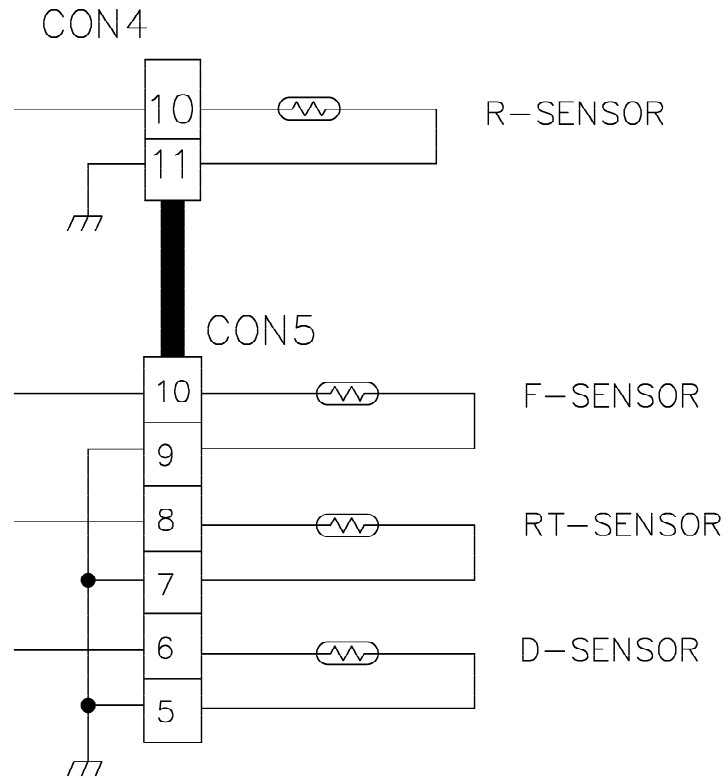

8-2-4 Motor Damper Circuit

A reversible DC motor is used to open and close the damper.

To open the damper, push test button once.

To close the damper, push test button twice.

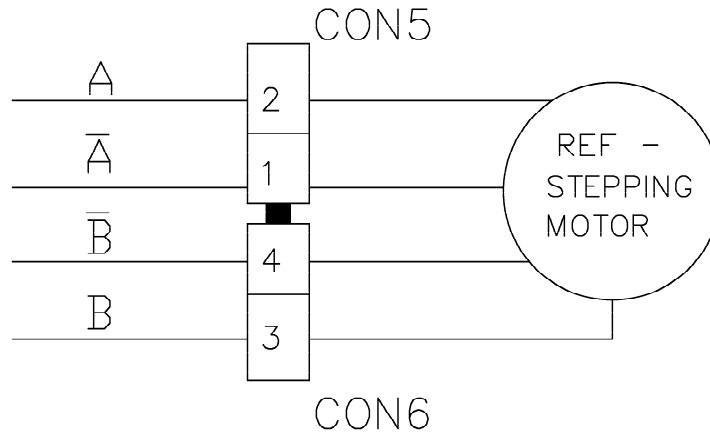

8-2-5 Damper Heater

* The damper heater is attached to the baffle and will always be on if the unit is powered on. The damper heater uses 12VDC.

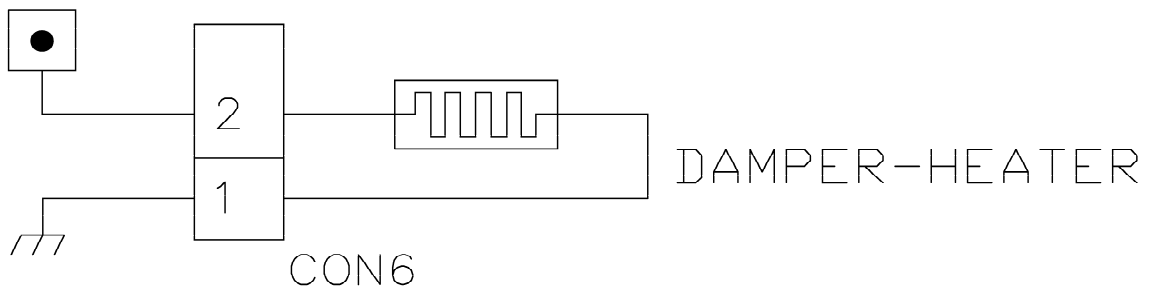

8-2-6 Key Button Input & Display Light On Circuit

LED CHECK MODE: When the COLDER(ADJUST) button in the refrigerator temperature control and the COLDER(ADJUST) button in the freezer temperature control are pushed and held for 1 second or longer, every LED on the display turns on at the same time. When the buttons are released, the previous mode is restored.

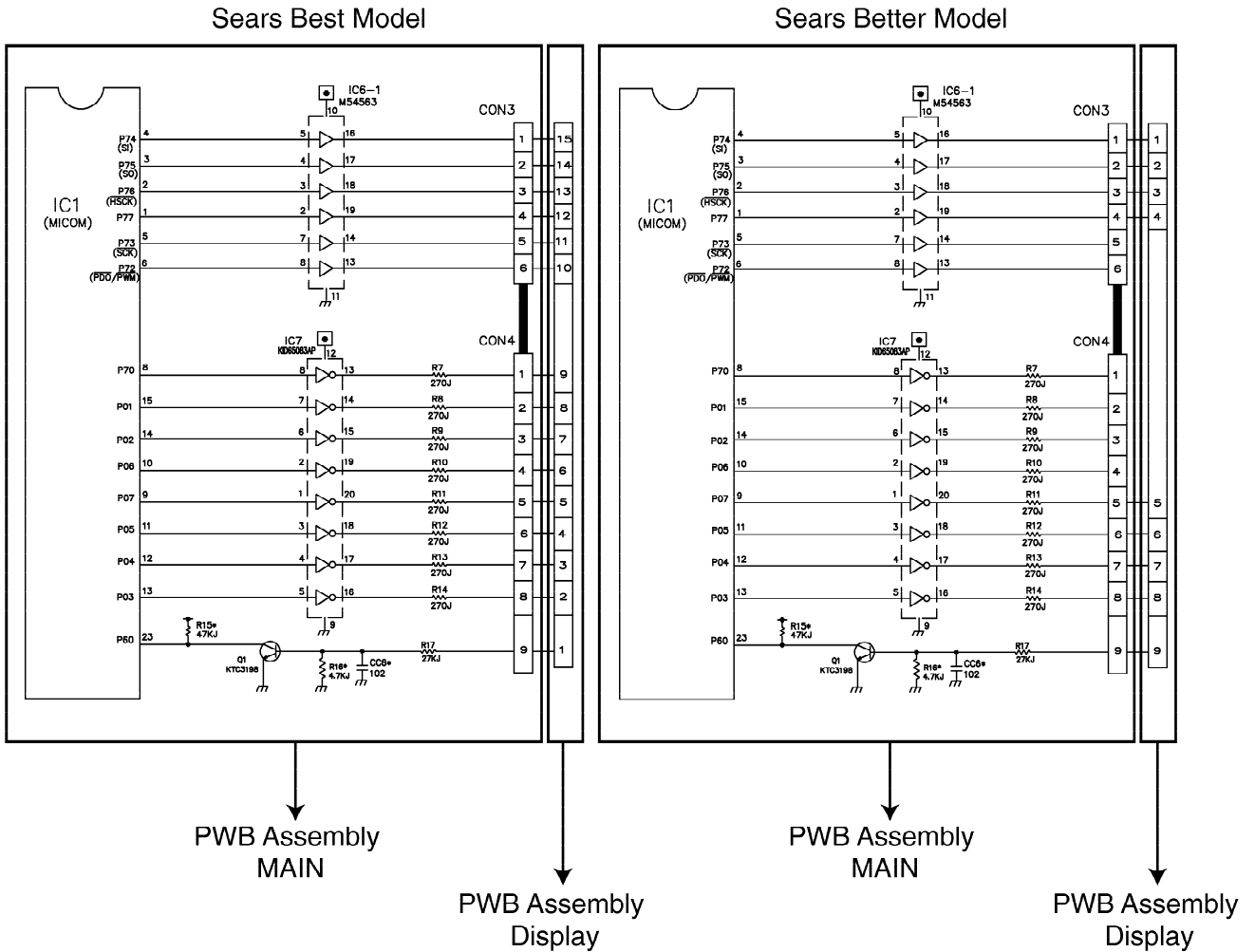

8-3 RESISTANCE SPECIFICATION OF SENSOR

TEMPERATURE	RESISTANCE OF FREEZER SENSOR	RESISTANCE OF REFRIGERATOR & DEFROST SENSOR & ROOM SENSOR
- 20 °C (-4 °F)	22.3 KΩ	77 KΩ
- 15 °C (5 °F)	16.9 KΩ	60 KΩ
- 10 °C (14 °F)	13.0 KΩ	47.3 KΩ
- 5 °C (23 °F)	10.1 KΩ	38.4 KΩ
0 °C (32 °F)	7.8 KΩ	30 KΩ
+ 5 °C (41 °F)	6.2 KΩ	24.1 KΩ
+ 10 °C (50 °F)	4.9 KΩ	19.5 KΩ
+ 15 °C (59 °F)	3.9 KΩ	15.9 KΩ
+ 20 °C (68 °F)	3.1 KΩ	13 KΩ
+ 25 °C (77 °F)	2.5 KΩ	11 KΩ
+ 30 °C (86 °F)	2.0 KΩ	8.9 KΩ
+ 40 °C (104 °F)	1.4 KΩ	6.2 KΩ
+ 50 °C (122 °F)	0.8 KΩ	4.3 KΩ

- The resistance of the SENSOR has a $\pm 5\%$ tolerance.
- Measure the resistance of the SENSOR after leaving it for over 3 minutes in the measuring temperature. This delay is necessary due to sensor response speed.

8-4 TROUBLESHOOTING

COMPLAINT	SYMPTOM	POSSIBLE CAUSES	SOLUTION
Electronic Display not operating correctly	1. No Display at all	<ol style="list-style-type: none"> 1. Supply voltage not within specifications 2. Open in wiring harness from PWB board 3. Open in door monitor switch circuit 	<ol style="list-style-type: none"> 1. Check supply voltage to refrigerator 2. Check wiring and connectors to PWB board 3. Check door monitor circuit
	2. Partial or abnormal display	<ol style="list-style-type: none"> 1. Supply voltage not within specifications 2. Open in wiring harness from PWB board 	<ol style="list-style-type: none"> 1. Check supply voltage to refrigerator 2. Check wiring and connectors to and from PWB board
Not Cooling	<ol style="list-style-type: none"> 1. Display on but compressor not operating 	<ol style="list-style-type: none"> 1. Compressor not operating 2. Open in compressor circuit 	<ol style="list-style-type: none"> 1. Check for compressor operation by using the test key on main circuit board 2. Check for open on OLP, PTC, compressor, wiring, etc.
Not cold enough	<ol style="list-style-type: none"> 2. Display on compressor is operating 	<ol style="list-style-type: none"> 1. Condenser fan motor not operating 2. Condenser coils blocked 3. Evaporator fan motor not operating 4. Damper not opening or internal air flow blocked 5. Sensor not operating properly 6. Door not sealing 7. Evaporator Frosted up 8. Sealed System related problem 	<ol style="list-style-type: none"> 1. Check condenser fan motor and wiring circuit 2. Check air flow across condenser 3. Check evaporator fan motor and wiring circuit 4. Check damper motor circuit 5. Check refrigerator and freezer sensors 6. Check for proper door seal 7. Check defrost circuit components
		<ol style="list-style-type: none"> 1. Open in defrost circuit 2. Defrost sensor not operating correctly 3. Defrost drain clogged 	<ol style="list-style-type: none"> 1. Check defrost heater and circuit using Test Key 2. Check sensor 3. Check drain
Not defrosting	<ol style="list-style-type: none"> 1. Frosted up in Freezer 	<ol style="list-style-type: none"> 1. Open in defrost circuit 2. Defrost sensor not operating correctly 3. Defrost drain clogged 	<ol style="list-style-type: none"> 1. Check defrost heater and circuit using Test Key 2. Check sensor 3. Check drain

8-5 MAIN PWB ASS'Y

8-5-1 Main PWB Ass'y

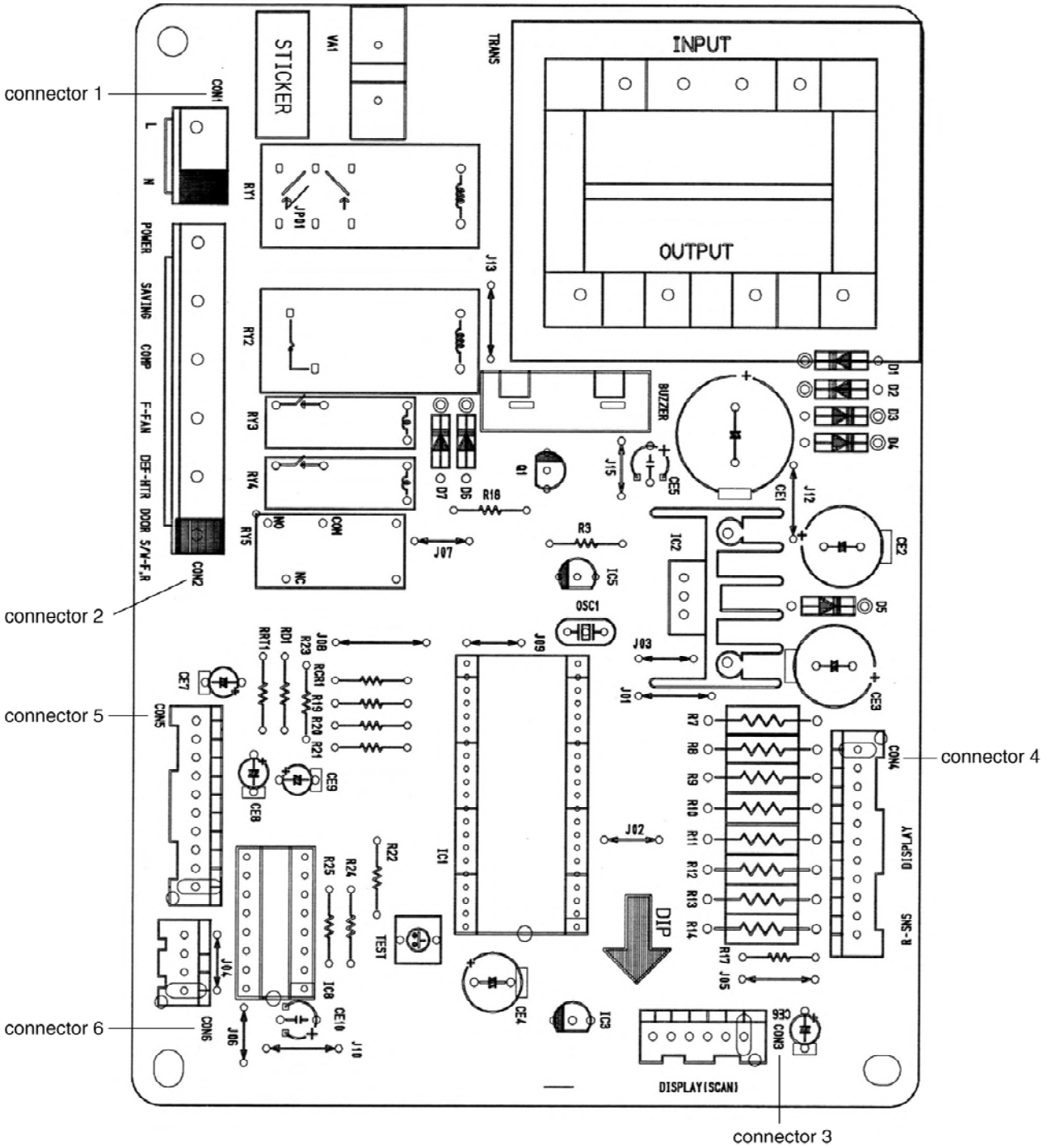

CASE PARTS

CAUTION: Use the part number to order part, not the location number.

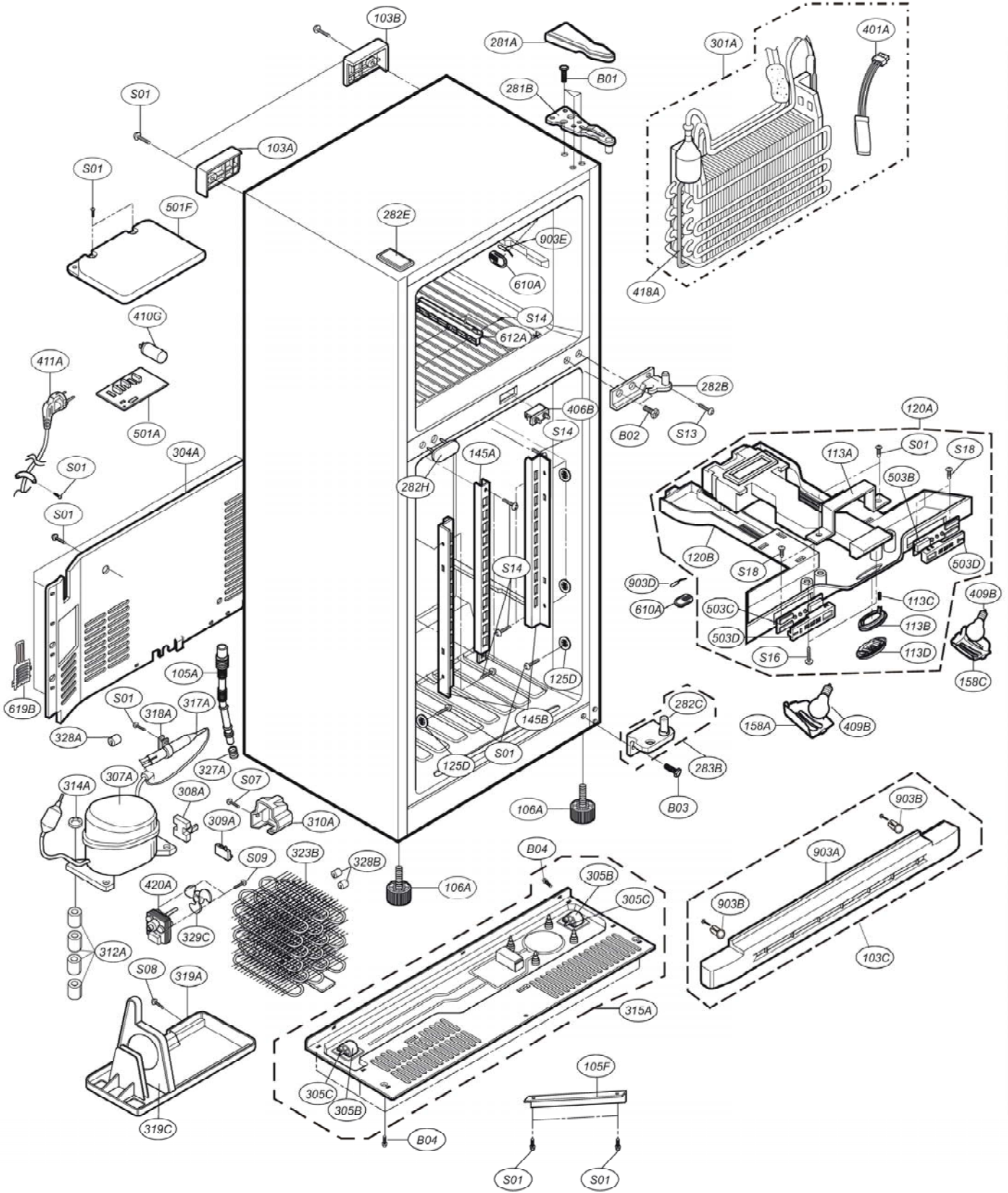

CASE PARTS

LOC #	PARTNUMBERBY MODEL		DESCRIPTION
	795.73259401	795.73959401	
	795.73252401	795.73952401	
	795.73254401	795.73954401	
105A	5251JA3003B	5251JA3003B	DRAIN ASSEMBLY,PIPE-Z
105F	5070JJ3002A	5070JJ3002A	SKIRT,LOWER
106A	4779JA2003A	4779JA2003A	LEG ASSEMBLY,ADJUST
113A	4930JJ2008A	4930JJ2008A	HOLDER,BRACKET
113B	4930JJ2005A	4930JJ2005A	HOLDER,GASKET
113C	4970JA3016A	4970JA3016A	SPRING,W
113D	4986JJ2003A	4986JJ2003A	GASKET,BETTA
120A	4995JJ1003D	4995JJ1003H	CONTROLBOX ASSEMBLY,R
120B	4994JJ0001A	4994JJ0001A	CONTROLBOX,R
125D	4930JJ3007A	4930JJ3007A	HOLDER,BRACKET
145A	4930JJ2003A	4930JJ2003A	HOLDER,SHELF
145B	4930JJ2004A	4930JJ2004A	HOLDER,SHELF
158A	3550JJ2019B	3550JJ2019B	COVER,LAMP
158C	3550JJ2019A	3550JJ2019A	COVER,LAMP
281B	4775JJ2003B	4775JJ2003B	HINGE ASSEMBLY,U
282B	4775JJ2002A	4775JJ2002A	HINGE ASSEMBLY,C
282C	1PZZJJ3002F	1PZZJJ3002F	PIN,DRAWING
283B	4775JJ2013B	4775JJ2013B	HINGE ASSEMBLY,L
301A	5421JJ0002A	5421JJ0002A	EVAPORATOR ASSEMBLY
304A	3551JJ2008B	3551JJ2008A	COVER ASSEMBLY,BACK-M/C
305B	4580JJ3001A	4580JJ3001A	ROLLER
305C	4J04238A	4J04238A	PIN,DRAWING
307A	2521C-A5725	2521C-A5725	COMPRESSOR,SET ASSEMBLY
308A	6748C-0004D	6748C-0004D	P.T.C ASSEMBLY
309A	6750CR0004S	6750CR0004S	O.L.P
310A	3550JA2042A	3550JA2042A	COVER,P.T.C
312A	5040JA3067A	5040JA3067A	RUBBER,SEAT
314A	4620JA3009A	4620JA3009A	STOPPER,COMP
315A	3103JJ1001J	3103JJ1001K	COMPBASE ASSEMBLY,STD
317A	5851JJ2002B	5851JJ2002B	DRIER ASSEMBLY
318A	4930JJ3002A	4930JJ3002A	HOLDER,DRIER
319A	3390JJ0003A	3390JJ0003A	TRAY,DRIP
319C	4974JJ1009A	4974JJ1009A	GUIDE,FAN
323B	5403JJ1003A	5403JJ1003A	CONDENSER ASSEMBLY,WIRE
327A	5006JA3034A	5006JA3034A	CAP,DRAINPIPE
328A	4J04328A	4J04328A	RUBBER,DAMPING
328B	4J03020A	4J03020A	RUBBER,DAMPING
329C	5901JJ1004B	5901JJ1004B	FAN ASSEMBLY
401A	4781JK2001A	4781JK2001A	CONTROLLER ASSEMBLY
409B	6912JK2002A	6912JK2002A	LAMP,(INCANDESCENT)
410G	0CZZJB2003H	0CZZJB2003H	CAPACITOR,DRAWING
411A	6411JK1006A	6411JK1006A	POWERCORD ASSEMBLY
418A	5300JK1003J	5300JK1003D	HEATER,SHEATH
420A	4680JK1001B	4680JK1001B	MOTOR(MECH),COOLING
501A	6871JB1185B	6871JB1185B	PWB(PCB) ASSEMBLY,MAIN
501F	3550JJ2016A	3550JJ2016A	COVER,PWB
503B	6871JB2044A	6871JB2044A	PWB(PCB) ASSEMBLY,DISPLAY
503C	6871JB2044B	6871JB2044B	PWB(PCB) ASSEMBLY,DISPLAY
503D	3110JJ2002A	3110JJ2002A	CASE,DISPLAY
610A	3550JJ2020A	3550JJ2020A	COVER,SENSOR
612A	4974JJ2006A	4974JJ2006A	GUIDE,RAIL
619B	3550JJ2024A	3550JJ2024A	COVER,VALVE
903B	4930JJ2021A	4930JJ2021A	HOLDER,COVERLOWER
903D	6500JK1003A	6500JK1003A	SENSOR
903E	6500JK1004A	6500JK1004A	SENSOR
B01	J351-00004L	J351-00004L	SCREW,DRAWING
B02	J351-00004R	J351-00004R	SCREW,DRAWING
B03	J351-00004P	J351-00004P	BOLT,DRAWING
B04	1BZZJA2002A	1BZZJA2002A	BOLT,DRAWING
S01	4J00415D	4J00415D	SCREW,DRAWING
S07	4000W4A003A	4000W4A003A	SCREW,DRAWING
S08	1SZZJJ3017A	1SZZJJ3017A	SCREW,DRAWING
S09	1SZZJA3016A	1SZZJA3016A	SCREW,DRAWING
S13	1SZZJJ3010A	1SZZJJ3010A	SCREW,DRAWING
S14	3J05696W	3J05696W	SCREW,DRAWING
S16	4J01424D	4J01424D	SCREW,DRAWING
S18	1TCL0302818	1TCL0302818	SCREW TAPPING,COUNTERSUNKHEAD

LOC #	PART NUMBER	MODEL(S)	MODEL(S)							DESCRIPTION
			795.73259401	795.73252401	795.73254401	795.73959401	795.73952401	795.73954401		
103A	3650JJ2003	M	E	F	M	E	F	HANDLE, BACK		
103B	3650JJ2003	L	A	B	L	A	B	HANDLE, BACK		
103C	3551JJ1015	F	B	D	E	A	C	COVER ASSEMBLY, LOWER		
281A	3550JJ2013	C	A	B	C	A	B	COVER, HINGE		
282E	5006JJ2001	F	A	E	F	A	E	CAP, HINGE		
282H	5006JJ3004	E	A	A	E	A	A	CAP, HINGE		
406B	6600JB2004	B	A	A	B	A	A	SWITCH, [PUSH]		
903A	3550JJ0006	C	A	B				COVER, LOWER		
903A	3550JJ0005				C	A	B	COVER, LOWER		

CAUTION: Use the part number to order part, not the location number

TO FIND OUT YOUR MODEL PART NUMBER YOU MUST TO SELECT THE PART NUMBER AND CHOOSE THE LETTER THAT IS ALIGNED WITH THE MODEL THAT CORRESPOND TO YOUR REFRIGERATOR

FREEZER PARTS

CAUTION: Use the part number to order part, not the location number.

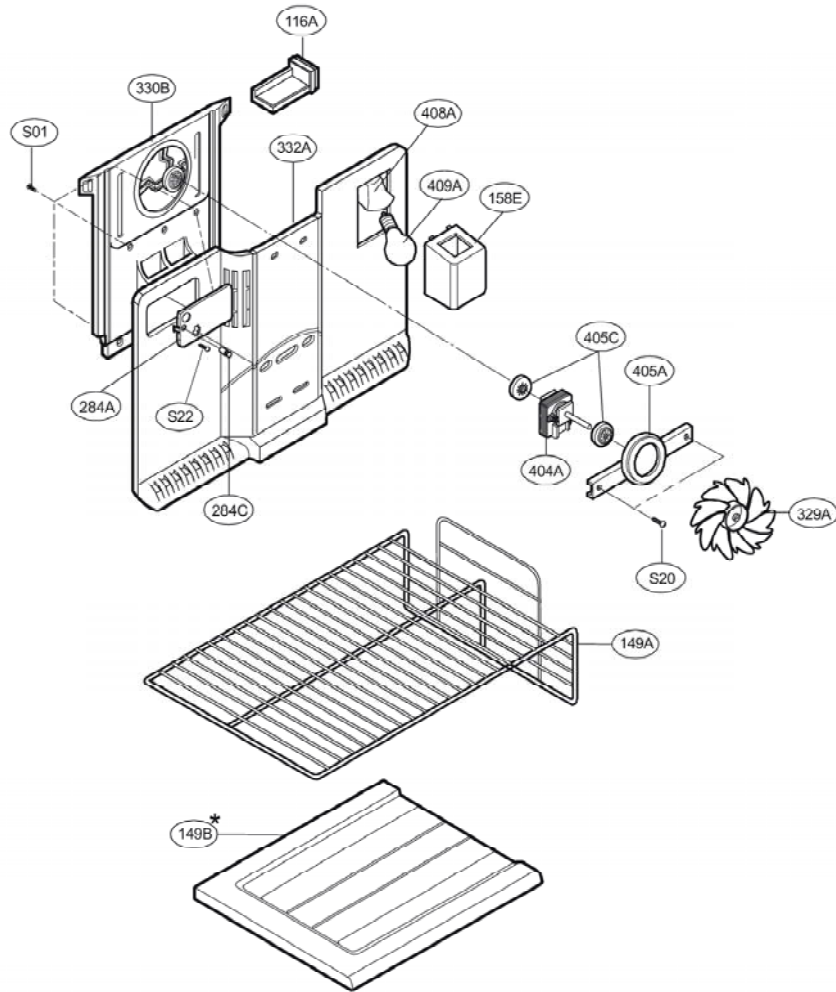

LOC #	PARTNUMBERBY MODEL		DESCRIPTION
	795.73252401	795.73952401	
116A	4901JK1001A	4901JK1001A	DAMPER ASSEMBLY,MOTOR
149A	5026JJ1018A	5026JJ1018A	SHELF,F
149B	5026JJ1017A	5026JJ1017A	SHELF,F
158E	3550JJ2017B	3550JJ2017B	COVER,LAMP
284A	3550JJ2023A	3550JJ2023A	COVER,GRILLEF AN
284C	5006JA3080A	5006JA3080A	CAP,SCREW
329A	5901JJ1003A	5901JJ1003A	FAN ASSEMBLY
330B	4998JJ1004A	4998JJ1004A	SHROUD,F
332A	3531JJ1002B	3531JJ1002A	GRILLE ASSEMBLY,FAN
404A	4681JB1016J	4681JB1016J	MOTOR ASSEMBLY,REF F AN
405A	4810JJ3003A	4810JJ3003A	BRACKET,MOTOR
405C	5040JA3049A	5040JA3049A	RUBBER,MOTOR-N
408A	6621JK2001A	6621JK2001A	SOCKET ASSEMBLY,LAMP
409A	6912JK2002D	6912JK2002D	LAMP,[INCANDESCENT]
S01	4J00415D	4J00415D	SCREW ASSEMBLY
S20	4001JA3001A	4001JA3001A	SCREW,DRAWING
S22	4J01425A	4J01425A	SCREW,DRAWING

CAUTION: Use the part number to order part, not the location number

TO FIND OUT YOUR MODEL PART NUMBER YOU MUST TO SELECT THE PART NUMBER AND CHOOSE THE LETTER THAT IS ALIGNED WITH THE MODEL THAT CORRESPOND TO YOUR REFRIGERATOR

REFRIGERATOR PARTS

CAUTION: Use the part number to order part, not the location number.

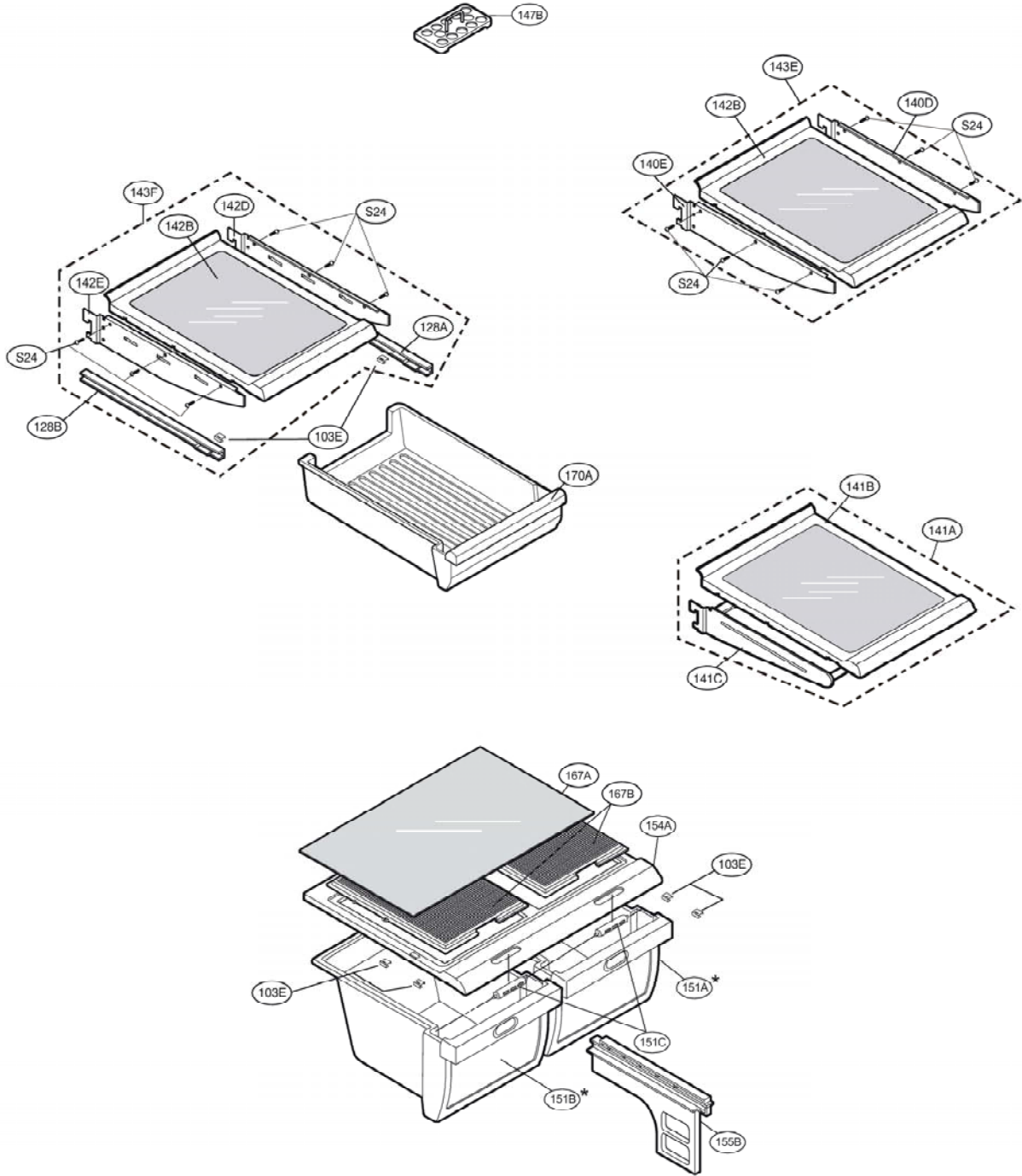

DOOR PARTS

CAUTION: Use the part number to order part, not the location number.

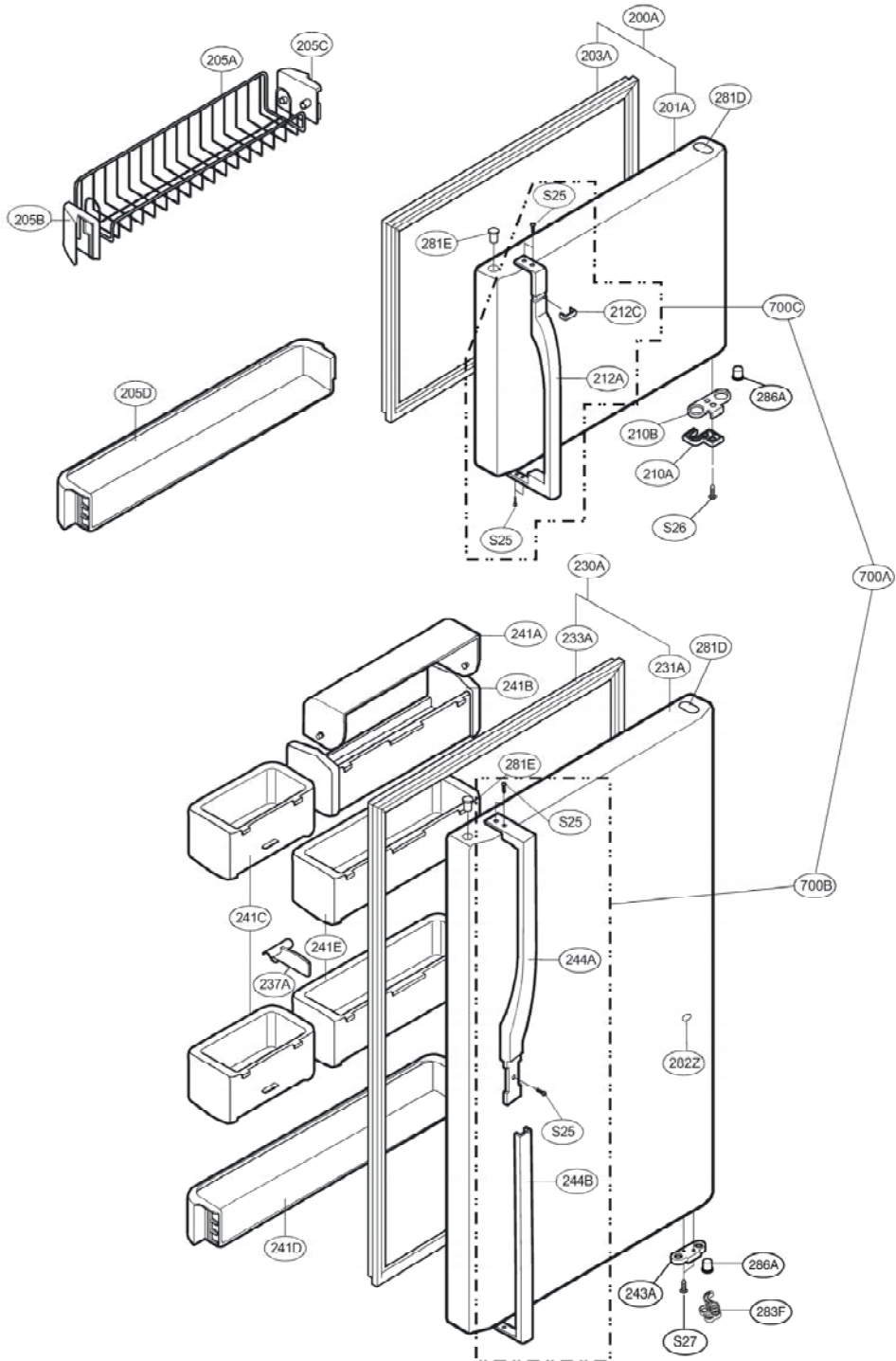

REFRIGERATOR PARTS

LOC #	PARTNUMBERBY MODEL		DESCRIPTION
	795.73252401 795.73254401 795.73259401	795.73952401 795.73954401 795.73959401	
103E	5218JJ3001A	5218JJ3001A	RAIL,SLIDE
128A	4975JJ2002A	4975JJ2002A	GUIDE ASSEMBLY,RAIL
128B	4975JJ2002B	4975JJ2002B	GUIDE ASSEMBLY,RAIL
140D	5026JJ2001G	5026JJ2001G	SHELF,NET
140E	5026JJ2001H	5026JJ2001H	SHELF,NET
141A	5027JJ1014P	5027JJ1014N	SHELF ASSEMBLY,R
141B	5027JJ1038A	5027JJ1036A	SHELF ASSEMBLY,R
141C	5027JJ2005C	5027JJ2005A	SHELF ASSEMBLY,NET
142B	5027JJ1039A	5027JJ1037A	SHELF ASSEMBLY,R
142D	5026JJ2001L	5026JJ2001L	SHELF,NET
142E	5026JJ2001M	5026JJ2001M	SHELF,NET
143E	5027JJ1013R	5027JJ1013N	SHELF ASSEMBLY,R
143F	5027JJ1013S	5027JJ1013P	SHELF ASSEMBLY,R
147B	3390JJ1014A	3390JJ1014A	TRAY,EGG
151A	3391JJ1018C	3391JJ1018A	TRAY ASSEMBLY,VEGETABLE
151B	3391JJ1018D	3391JJ1018B	TRAY ASSEMBLY,VEGETABLE
151C	4940JJ2003A	4940JJ2003A	KNOB,SHUTTER
154A	3550JL2001C	3550JL2001A	COVER,T/V
155B	4980JJ1010A	4980JJ1010A	SUPPORTER,COVER-T/V
167A	4890JL1002V	4890JL1002U	GLASS,SHELF
167B	3550JJ1012A	3550JJ1011A	GLASS,SHELF
170A	3391JJ2004B	3391JJ2004A	TRAY ASSEMBLY,MEAT
S24	1SZZJA3011B	1SZZJA3011B	SCREW,DRAWING

DOOR PARTS

LOC #	PART NUMBER	MODEL(S)	795.73259401	795.73252401	795.73254401	795.73959401	795.73952401	795.73954401	DESCRIPTION
200A	3581JJ8012					C	A	B	DOOR ASSEMBLY, F
200A	3581JJ8016		C	A	B				DOOR ASSEMBLY, F
201A	5433JJ1001		C	A	B				DOOR FOAM ASSEMBLY, F
201A	5433JJ1003					C	A	B	DOOR FOAM ASSEMBLY, F
203A	4987JJ1004		X	T	T	V	R	R	GASKET, ASSEMBLY, DOOR
205A	5004JJ1017		B	B	B	A	A	A	BASKET, DOOR
205B	5004JJ2002		A	A	A	A	A	A	BASKET, TILT
205C	5004JJ2003		A	A	A	A	A	A	BASKET, TILT
205D	5004JJ1024		A	A	A				BASKET, DOOR
205D	5004JJ1015					A	A	A	BASKET, DOOR
210A	4620JJ2006		B	A	A	B	A	A	STOPPER, DOOR
210B	4974JA3031		B	B	B	B	B	B	GUIDE, STOPPER
212A	3650JJ1013		B	A	C	B	A	C	HANDLE, F
212C	3650JJ2007		C	A	B	C	A	B	HANDLE, PIECE
230A	3581JJ8013					K	B	F	DOOR ASSEMBLY, R
230A	3581JJ8017		K	B	F				DOOR ASSEMBLY, R
231A	5433JJ0015		K	B	F				DOOR FOAM ASSEMBLY, R
231A	5433JJ0020					K	B	F	DOOR FOAM ASSEMBLY, R
233A	4987JJ1004		Y	U	U	W	S	S	GASKET ASSEMBLY, DOOR
237A	4974JJ2021		A	A	A	A	A	A	GUIDE, BOTTLE
241A	3550JL2003		B	B	B	A	A	A	COVER, TRAY
241B	5004JJ1021		A	A	A				BASKET, DOOR
241B	5004JJ1035					A	A	A	BASKET, DOOR
241C	5004JJ1031		A	A	A				BASKET, DOOR
241C	5004JJ1030					A	A	A	BASKET, DOOR
241D	5004JJ1027		A	A	A				BASKET DOOR
241D	5004JJ1026					A	A	A	BASKET, DOOR
241E	5004JJ1029		A	A	A				BASKET, DOOR
241E	5004JJ1028					A	A	A	BASKET, DOOR
243A	4620JJ3006		C	A	B	C	A	B	STOPPER, DOOR
244A	3650JJ1014		B	A	C	B	A	C	HANDLE, R
244B	3650JJ1015		B	A	C				HANDLE, DECO
244B	3650JJ1016					B	A	C	HANDLE, DECO
281D	5006JJ3007		C	A	B	C	A	B	CAP, HINGE
281E	5006JJ3003		E	A	D	E	A	D	CAP, HINGE
282Z	5006JA3055		K	A	L	K	A	L	CAP, HINGE
283F	4620JJ2007		B	A	A	B	A	A	STOPPER,DOOR
286A	4984JJ3003		A	A	A	A	A	A	BUSH
700A	3651JJ1002		G	A	D	H	B	E	HANDLE ASSEMBLY,PACKAGE
700B	3651JJ8001		W	Y	X	T	S	U	HANDLE ASSEMBLY,F
700C	3651JJ8002		W	X	X	T	S	U	HANDLE ASSEMBLY,R
S25	1SZZJJ3010		D	B	E	D	B	E	SCREW, DRAWING
S26	1SZZJJ3003		D	D	D	D	D	D	SCREW, DRAWING
S27	4J01424C		C	C	C	C	C	C	SCREW, DRAWING

CAUTION: Use the part number to order part, not the location number

TO FIND OUT YOUR MODEL PART NUMBER YOU MUST TO SELECT THE PART NUMBER AND CHOOSE THE LETTER THAT IS ALIGNED WITH THE MODEL THAT CORRESPOND TO YOUR REFRIGERATOR



*'You Can Count on me . . .
to Work Safely.'*